

Flexi Compact

Safety controller

SICK
Sensor Intelligence.



Described product

Flexi Compact

Manufacturer

SICK AG
Erwin-Sick-Str. 1
79183 Waldkirch
Germany

Legal information

This work is protected by copyright. Any rights derived from the copyright shall be reserved for SICK AG. Reproduction of this document or parts of this document is only permissible within the limits of the legal determination of Copyright Law. Any modification, abridgment or translation of this document is prohibited without the express written permission of SICK AG.

The trademarks stated in this document are the property of their respective owner.

© SICK AG. All rights reserved.

Original document

This document is an original document of SICK AG.

EtherCAT®

EtherCAT® and Safety over EtherCAT® are registered trademarks and patented technologies, licensed by Beckhoff Automation GmbH, Germany.

The backplane bus is based on EtherCAT® and Safety over EtherCAT®.



Contents

1	About this document.....	7
1.1	Purpose of this document.....	7
1.2	Scope.....	7
1.3	Target groups and structure of these operating instructions.....	8
1.4	Further information.....	8
1.5	Symbols and document conventions.....	8
2	Safety information.....	10
2.1	General safety notes.....	10
2.2	Intended use.....	10
2.3	Improper use.....	10
2.4	Cybersecurity.....	11
2.5	Requirements for the qualification of personnel.....	11
3	Product description.....	12
3.1	Configuration of the safety controller.....	12
3.2	Overview of the module.....	13
3.3	Design and function of the module.....	14
3.4	Status indicators.....	15
3.5	Interfaces.....	16
3.5.1	SmartPlug.....	16
3.5.2	TCP/IP configuration interface (CPUc2).....	16
4	Project planning.....	18
4.1	Manufacturer of the machine.....	18
4.2	Operating entity of the machine.....	18
4.3	Design.....	18
4.4	Muting application.....	19
4.4.1	Safety notes for muting applications.....	19
4.4.2	Overview and general description.....	22
4.4.3	Notes on wiring.....	27
4.5	Electrical integration.....	28
4.5.1	Internal circuitry.....	28
4.5.2	Fault detection using test outputs.....	29
4.5.3	Safety outputs.....	29
4.5.4	Single-channel use of safety inputs.....	30
4.6	Integration into the network.....	30
4.6.1	Network topology.....	30
4.6.2	Integration via the fieldbus interface.....	30
4.7	Testing plan.....	31
5	Mounting.....	33
5.1	Mounting procedure.....	33
5.2	Mounting the SmartPlug.....	34

5.3	Disassembly.....	35
5.4	Module exchange.....	36
6	Electrical installation.....	38
6.1	Connecting.....	38
6.1.1	Front connector.....	38
6.1.2	RJ45 port connection.....	40
6.2	Coding.....	41
6.2.1	Coding front connector and module.....	41
7	Configuration.....	43
7.1	Delivery state.....	43
7.2	Safety Designer configuration software.....	43
7.2.1	User interface.....	43
7.2.2	User groups.....	44
7.3	Offline, online and security configuration.....	45
7.4	Overview main navigation menu.....	46
7.5	Configuration main navigation menu.....	46
7.5.1	Identification.....	47
7.5.2	Protecting the configuration in the SmartPlug with a password.....	48
7.5.3	Adding expansion modules.....	48
7.5.4	Input elements.....	49
7.5.5	Output elements.....	52
7.5.6	Adding, configuring and expanding elements.....	54
7.5.7	Creating customized elements.....	55
7.6	Configuring the network interfaces.....	56
7.6.1	Configuring Modbus connections.....	56
7.6.2	Configuring SLMP connections.....	57
7.6.3	Configuring the output data (routing to CPU).....	57
7.6.4	Configuring the input data (routing to network).....	57
7.7	Logic editor main navigation.....	58
7.7.1	Inputs.....	59
7.7.2	Function blocks.....	60
7.7.3	Outputs.....	110
7.7.4	Diagnostics.....	110
7.7.5	Jump addresses.....	111
7.7.6	Logic programming in the logic editor.....	112
7.7.7	Logic execution time.....	113
7.7.8	I/O matrix.....	113
7.7.9	I/O summary page.....	113
7.7.10	Simulation mode.....	114
7.8	Report main navigation menu.....	115
7.9	Service main navigation menu.....	115
7.9.1	Assigning or changing passwords.....	115
7.9.2	Resetting the password.....	116

7.10	Establishing a connection.....	116
7.11	Transferring the configuration.....	116
7.12	Verification.....	117
7.12.1	Verifying the configuration content and configuration transfer at the same time.....	118
7.13	Checksums.....	118
7.14	Testing safety functions.....	119
8	Commissioning.....	120
8.1	Check during commissioning and modifications.....	120
9	Operation.....	121
9.1	Status indicators.....	121
9.2	Regular thorough check.....	123
10	Maintenance.....	124
10.1	Regular thorough check.....	124
11	Troubleshooting.....	125
11.1	Possible faults.....	125
11.2	Diagnostics using Safety Designer.....	127
11.2.1	Error history.....	127
12	Decommissioning.....	129
12.1	Disposal.....	129
13	Technical data.....	130
13.1	Data sheet.....	130
13.2	Maximum response time.....	135
13.2.1	Calculating the response time.....	136
13.2.2	Example response time calculation.....	139
13.3	Data exchange in the network.....	142
13.3.1	Modbus® TCP.....	142
13.3.2	SLMP.....	147
13.4	Dimensional drawings.....	150
14	Ordering information.....	152
14.1	Scope of delivery.....	152
14.2	Ordering information for main module.....	152
14.3	Ordering information for expansion module.....	152
14.4	Ordering information for accessories.....	152
15	Annex.....	154
15.1	Conformities and certificates.....	154
15.1.1	EU declaration of conformity.....	154
15.1.2	UK declaration of conformity.....	154
16	List of figures.....	155

17 List of tables..... 157

1 About this document

1.1 Purpose of this document

These operating instructions contain the information required during the life cycle of the safety controller.

Operating instructions of the safety controller must be made available to all people who work with the device.

1.2 Scope

Product

This document applies to the following products:

- Product code: Flexi Compact
- “Operating instructions” type label entry: 8024573

Document identification

Document part number:

- This document: 8024589
- Available language versions of this document: 8024573

You can find the current version of all documents at www.sick.com.

Other documents relevant for the product

Table 1: Available documents

Document	Title	Part number
Operating instructions	Flexi Compact safety controller	8024573
Operating instructions	FLX3-XTDI1 Expansion module for safety controllers	8024571
Operating instructions	FLX3-XTDO1 Expansion module for safety controllers	8024570
Operating instructions	FLX0-GPNT1 Expansion module for safety controllers	8024567
Operating instructions	FLX0-GETC1 Expansion module for safety controllers	8024566
Operating instructions	FLX0-GCAN1 Expansion module for safety controllers	8024572
Operating instructions	Flexi Loop Safe Series Connection Hardware	8015834
Operating instructions	Flexi Loop in the Safety Designer Software	8018174
Competence brochure	Guide for Safe Machinery	8008007

1.3 Target groups and structure of these operating instructions

These operating instructions are intended for the following target groups: project developers (planners, developers, designers), installers, electricians, safety experts (such as CE authorized representatives, compliance officers, people who test and approve the application), operators, and maintenance personnel.

These operating instructions are organized by the life phases of the device: project planning, mounting, electrical installation, commissioning, operation and maintenance.

The table below shows the target groups and how – for many applications – these are typically divided up between the manufacturer and the entity operating the machine in which the device is to be integrated:

Area of responsibility	Target group	Specific chapters of these operating instructions ¹⁾
Manufacturer	Project developers (planners, developers, designers)	Project planning, page 18 Technical data, page 130
	Installers	Mounting, page 33
	Electricians	Electrical installation, page 38
	Safety experts	Project planning, page 18 Commissioning, page 120 Technical data, page 130
Operating entity	Operators	Troubleshooting, page 125
	Maintenance staff	Troubleshooting, page 125 Ordering information, page 152

¹⁾ Chapters not listed here are intended for all target groups. All target groups must follow all of the safety and warning instructions in all chapters of the operating instructions!

In other applications, the operating organization is also the manufacturer of the equipment with the corresponding allocation of the target groups.

1.4 Further information

www.sick.com

The following information is available via the Internet:

- Data sheets and application examples
- CAD files and dimensional drawings
- Certificates (such as the EU declaration of conformity)
- Guide for Safe Machinery. Six steps to a safe machine
- Safety Designer (software for configuring safety solutions made by SICK AG)

1.5 Symbols and document conventions

The following symbols and conventions are used in this document:

Safety notes and other notes



DANGER

Indicates a situation presenting imminent danger, which will lead to death or serious injuries if not prevented.

**WARNING**

Indicates a situation presenting possible danger, which may lead to death or serious injuries if not prevented.

**CAUTION**

Indicates a situation presenting possible danger, which may lead to moderate or minor injuries if not prevented.

**NOTICE**

Indicates a situation presenting possible danger, which may lead to property damage if not prevented.

**NOTE**

Indicates useful tips and recommendations.

Instructions to action

- ▶ The arrow denotes instructions to action.
- 1. The sequence of instructions for action is numbered.
- 2. Follow the order in which the numbered instructions are given.
- ✓ The check mark denotes the result of an instruction.

2 Safety information

2.1 General safety notes

Product integration



DANGER

The product can not offer the expected protection if it is integrated incorrectly.

- ▶ Plan the integration of the product in accordance with the machine requirements (project planning).
 - ▶ Implement the integration of the product in accordance with the project planning.
-

Mounting and electrical installation



DANGER

Death or severe injury due to electrical voltage and/or an unexpected startup of the machine

- ▶ Make sure that the machine is (and remains) disconnected from the voltage supply during mounting and electrical installation.
 - ▶ Make sure that the dangerous state of the machine is and remains switched off.
-

Repairs and modifications



DANGER

Improper work on the product

A modified product may not offer the expected protection if it is integrated incorrectly.

- ▶ Apart from the procedures described in this document, do not repair, open, manipulate or otherwise modify the product.
-

2.2 Intended use

The Flexi Compact safety controller is a freely configurable control for safety applications.

The product may be used in safety functions.

Sensors and switching elements (e.g. light curtains, laser scanners, switches, sensors, encoders, emergency stop pushbuttons) are connected to the safety controller and are linked logically. The corresponding actuators of the machines or systems can be switched off safely via the switching outputs of the safety controller.

Incorrect use, improper modification or manipulation of the product will invalidate any warranty from SICK; in addition, any responsibility and liability of SICK for damage and secondary damage caused by this is excluded.

The product is only suitable for use in industrial environments.

2.3 Improper use

Among others, the safety controller is not suitable for the following applications:

- Outdoors
- Underwater
- In explosion-hazardous areas
- In residential areas

2.4 Cybersecurity

Overview

To protect against cybersecurity threats, it is necessary to continuously monitor and maintain a comprehensive cybersecurity concept. A suitable concept consists of organizational, technical, procedural, electronic, and physical levels of defense and considers suitable measures for different types of risks. The measures implemented in this product can only support protection against cybersecurity threats if the product is used as part of such a concept.

You will find further information at www.sick.com/psirt, e.g.:

- General information on cybersecurity
- Contact option for reporting vulnerabilities
- Information on known vulnerabilities (security advisories)

2.5 Requirements for the qualification of personnel

The product must be configured, installed, connected, commissioned, and serviced by qualified safety personnel only.

Project planning

You need safety expertise to implement safety functions and select suitable products for that purpose. You need expert knowledge of the applicable standards and regulations.

Mounting, electrical installation and commissioning

You need suitable expertise and experience. You must be able to assess if the machine is operating safely.

Configuration

You need suitable expertise and experience. You must be able to assess if the machine is operating safely.

Operation and maintenance

You need suitable expertise and experience. You must be instructed in machine operation by the machine operator. For maintenance, you must be able to assess if the machine is operating safely.

3 Product description

3.1 Configuration of the safety controller

Configuration of the safety controller

A safety controller comprises the following components:

- A main module
- Up to 12 optional expansion modules (excluding maximum 1 gateway)

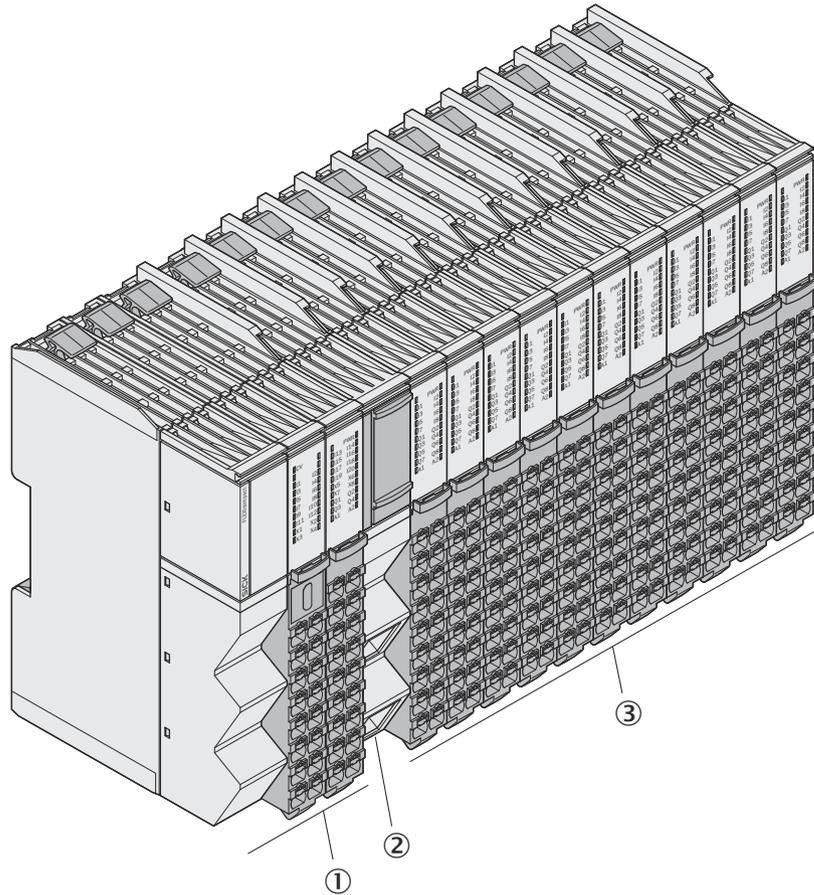

Figure 1: Example maximum configuration

- ① Main module
- ② Expansion module - gateway
- ③ IO expansion module

Complementary information

- The gateway and IO expansion modules can be arranged arbitrarily.

3.2 Overview of the module

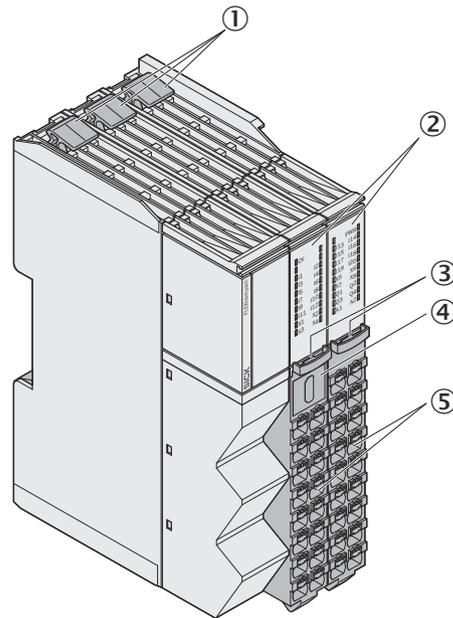

Figure 2: FLX3-CPUC1 module

- ① Release elements of the module
- ② Status indicators (LEDs)
- ③ Release elements of the front connector
- ④ SmartPlug with USB connection
- ⑤ Front connector with terminals (spring type)

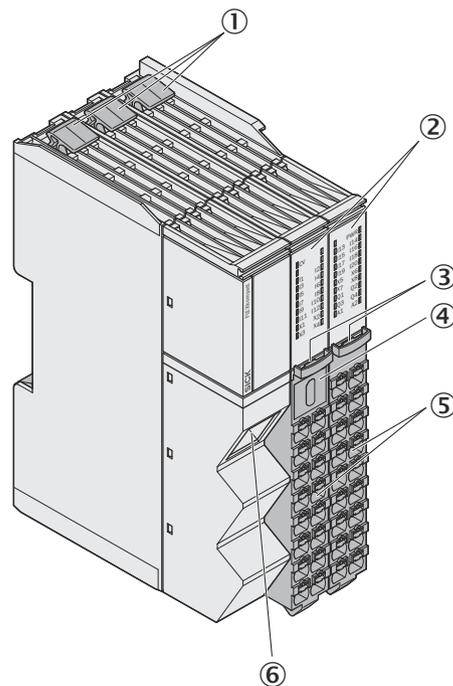

Figure 3: FLX3-CPUC2 module

- ① Release elements of the module
- ② Status indicators (LEDs)
- ③ Release elements of the front connector

- ④ SmartPlug with USB connection
- ⑤ Front connector with terminals (spring type)
- ⑥ RJ45 female Ethernet connector

3.3 Design and function of the module

Configuration

Table 2: Interfaces of the main module

Description	Quantity
Safety capable inputs	20
Safety capable outputs	4
Test outputs ¹⁾	8
Ethernet, Modbus® TCP, SLMP (RJ45 female connector)	CPUc1: 0 CPUc2: 1
SmartPlug	1

¹⁾ The test outputs can also be used to switch non-safety elements (e.g., lamps).

Function

The main module is the central processor unit of the modular safety controller. All incoming signals are monitored and logically processed in the main module. The outputs are switched based on this processing.

If the main module is used in conjunction with expansion modules, the communication with the expansion modules is via the backplane bus.

The module offers the following functions:

- Monitoring of the connected safety devices
- Switching of the connected safety devices
- Testing of the connected safety devices and the wiring (short-circuit detection)
- Use of the test outputs as non-safe outputs
- Programmable logic (binary logic, integer processing, application-specific function blocks)
- CPUc2: Ethernet interface as a TCP/IP configuration interface and data exchange via Modbus® TCP and SLMP
- Special IO functions (e.g., fast shut off)
- Flexi Loop safe series connection

Complementary information

- Each test output has an independent test pulse generator. This enables different test pulse parameters to be selected and short-circuits in the wiring to be detected.
- The element connected to the output during hardware configuration determines how the test output will be used. If the test output is used for a non-safety element (e.g., a lamp), then the test pulse is switched off for the output.
- Safety outputs have test pulses for detecting short-circuits in the wiring.

3.4 Status indicators

Status indicators

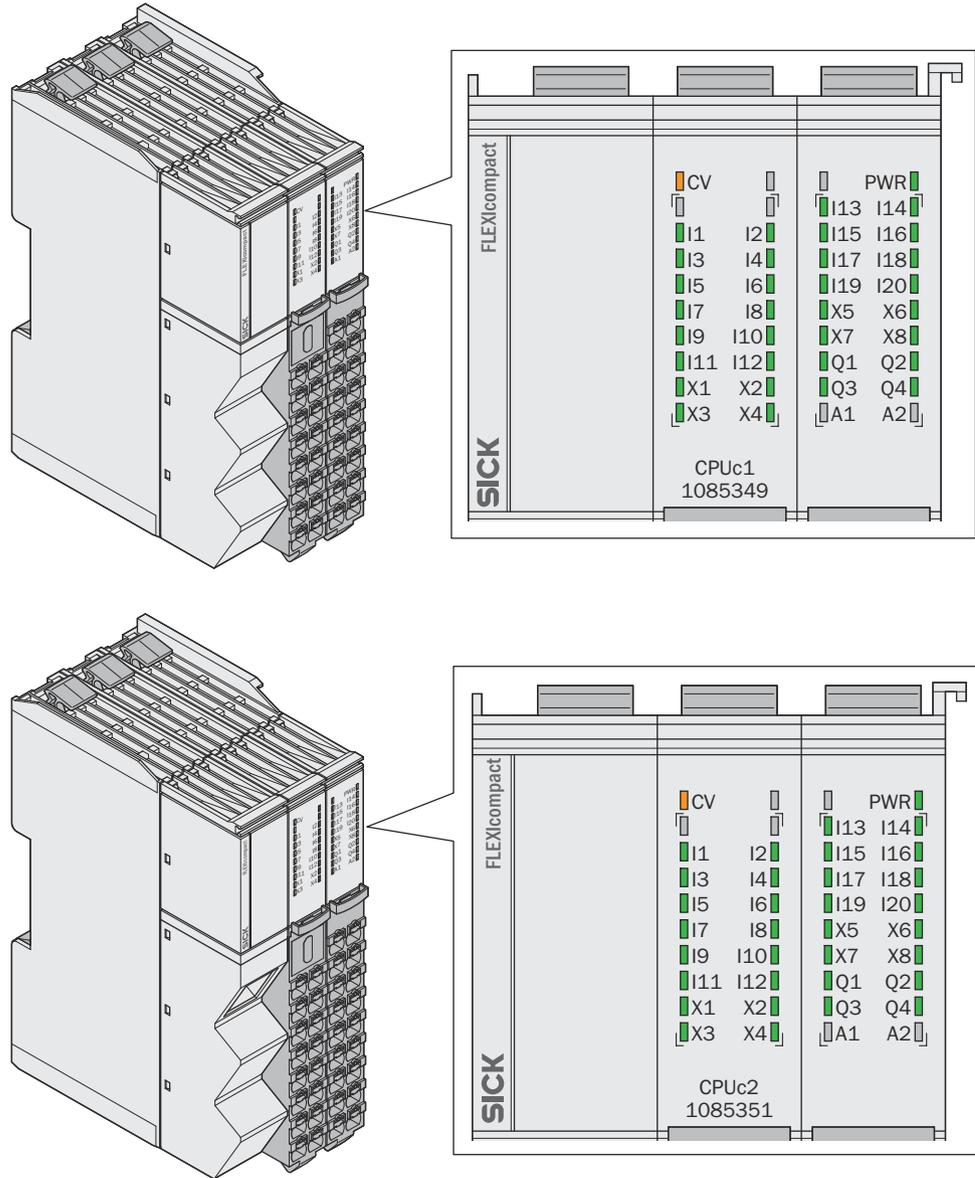

Figure 4: LEDs for indicating the status

The arrangement of the status indicators corresponds to the arrangement of the terminals.

Status indicator

Table 3: Status indicator

Labeling	Color	Function
PWR (power)	Green/Red	Device status
CV (configuration valid)	Yellow	Device configuration status
I1 ... I20	Green	Safety input 1 ... 20
X1 ... X8	Green	Test output 1 ... 8
Q1 ... Q4	Green	Safety output 1 ... 4

Further topics

- ["Status indicators", page 121](#)
- ["Troubleshooting", page 125](#)

3.5 Interfaces

3.5.1 SmartPlug

SmartPlug

The SmartPlug is the system memory plug of the safety controller.

When installed, the SmartPlug is located behind the front connector of the main module. The front connector with the SmartPlug must only be removed when there is no power to the system. The safety controller stops program execution immediately if the front connector with the SmartPlug is removed.

The SmartPlug has a USB port for configuration and diagnostics of the safety controller via a computer. The USB connection may only be used temporarily and only for configuration and diagnostics.

The safety controller can only be operated when a SmartPlug is plugged in.

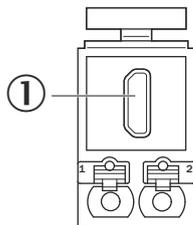

Figure 5: SmartPlug

- ① Micro-USB connection

The SmartPlug performs the following functions:

- Permanently saving the configuration data in the SmartPlug.
- The main module and configuration software can read the configuration data from the SmartPlug.
- When the module is replaced, the safety controller needs to be reconfigured.
- The stored data are also retained in the event of an interruption to the voltage supply.

Complementary information

If you use a display (e.g., on a gateway) to configure settings on the safety controller that can also be configured using the configuration software, the configuration in the SmartPlug is updated accordingly.

Further topics

- ["Mounting the SmartPlug", page 34](#)
- ["Ordering information for accessories", page 152](#)

3.5.2 TCP/IP configuration interface (CPUc2)

Important information



NOTE

The IP address must be assigned initially via the configuration software.

TCP/IP configuration interface (CPUc2)

You can carry out the following functions over Ethernet via the TCP/IP configuration interface of the CPUc2:

- Transferring the configuration
- Reading the configuration from the safety controller
- Diagnostics

4 Project planning

4.1 Manufacturer of the machine

The manufacturer of the machinery must carry out a risk assessment and apply appropriate protective measures. Further protective measures may be required in addition to the product.

The product must not be tampered with or changed, except for the procedures described in this document.

The product must only be repaired by the manufacturer of the product or by someone authorized by the manufacturer. Improper repair can result in the product not providing correct protection.

4.2 Operating entity of the machine

Changes to the electrical integration of the product in the machine controller and changes to the mechanical mounting of the product necessitate a new risk assessment. The results of this risk assessment may require the entity operating the machine to meet the obligations of a manufacturer.

After each change to the configuration, it is necessary to check whether the protective measure provides the necessary protection. The person making the change is responsible for ensuring that the protection measure provides the necessary protection.

The product must not be tampered with or changed, except for the procedures described in this document.

The product must only be repaired by the manufacturer of the product or by someone authorized by the manufacturer. Improper repair can result in the product not providing correct protection.

4.3 Design

Installation site

- The safety controller must be protected against condensation and conductive contamination, e.g. in an IP54 control cabinet.
- Mounting on a 35 mm × 7.5 mm mounting rail in accordance with IEC 60715.
- The mounting rail is connected to the functional earth.
- Mounting rail is mounted on a mounting plate.
- Mounting plate is connected to functional earth.
- Mounting in a vertical orientation (on a horizontal mounting rail). [figure 16](#)
- Take suitable ESD protection measures.

Air circulation

To ensure sufficient air circulation and cooling, sufficient distance must be kept in the control cabinet above and below the module.

Provide an adequate clearance in front of the module (front side) for the connected cables.

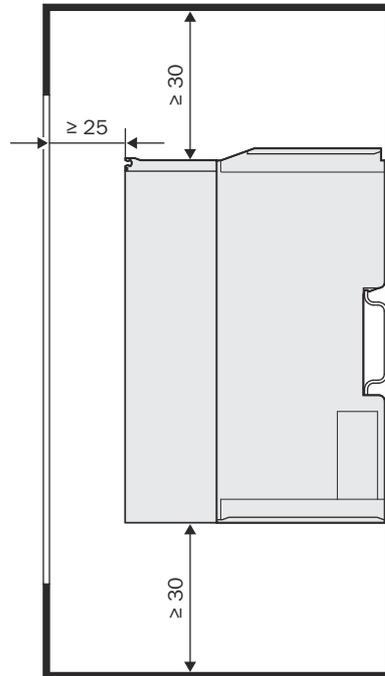

Figure 6: Clearances for adequate air circulation

Required distance:

- Above and below the module: ≥ 30 mm
- In front of the module: ≥ 25 mm

4.4 Muting application

4.4.1 Safety notes for muting applications

The safety functions of a protective device are bypassed by muting.



WARNING

Restricted safety through muting

The dangerous state may not be stopped or not be stopped in a timely manner in the event of non-compliance.

- ▶ Observe the general safety specifications and protective measures.
- ▶ You must always observe the following notes about how to use the muting function correctly.

General safety notes for muting

- ▶ Always observe the national, regional, and local regulations and standards that are applicable to the application.
- ▶ Make sure that the application is in line with an appropriate risk analysis and risk avoidance strategy.
- ▶ Muting must be setup to be carried out automatically but not be dependent on a single electrical signal.
- ▶ Never use muting to transport a person into the hazardous area.
- ▶ Make sure that muting is only activated for as long as access to the hazardous area remains blocked by the object responsible for triggering the muting condition.
- ▶ Make sure that the muting condition is terminated as soon as the object has finished passing through so that the protective device returns to its standard non-bypassed status (i.e., it must be reactivated).

- ▶ In the case of long muting cycles (i.e., those lasting more than 24 hours) or long machine downtimes, check the muting sensors to make sure they are functioning correctly.
- ▶ If the total muting time is set to infinite (inactive), use additional measures to prevent anyone from entering the hazardous area while muting is active.
- ▶ If safety-related information (i.e., remote safety capable input values and/or remote safety output values) is transmitted via a safety fieldbus network, always take the associated delay times into account. These delay times may influence both the system behavior and the minimum safety distance requirements associated with the response times.

Safety notes for the electro-sensitive protective equipment (ESPE)

- ▶ Access to the hazardous area must be reliably detected by the ESPE or other measures must be taken to prevent a person from bypassing, exceeding, crawling under or crossing the ESPE undetected.
- ▶ Observe the operating instructions for the electro-sensitive protective device that explain how to install and use the device correctly.
- ▶ Secure the area between the electro-sensitive protective device and the muting sensors as follows to prevent anyone standing behind:
 - With parallel muting – between the electro-sensitive protective device and sensors A1 / A2 as well as between the electro-sensitive protective device and sensors B1 / B2 (see figure 12, page 24).
 - With sequential muting – between the electro-sensitive protective device and sensor A2 as well as between the electro-sensitive protective device and sensor B1 (see figure 13, page 25).
 - With cross muting – between the electro-sensitive protective equipment and sensor A1 as well as between the electro-sensitive protective equipment and sensor A2 (see figure 14, page 26).

Safety notes for the muting sensors

- ▶ Set up muting so that it is triggered by at least two signals (e.g., from muting sensors) that are wired independently of one another and it is not fully dependent on software signals (e.g., from a PLC).
- ▶ Arrange the muting sensors so that if an intervention in the protective field occurs, the hazardous area can only be reached once the dangerous state has been eliminated. A condition for this is that the necessary minimum distances between the ESPE and the hazardous area are maintained, typically in accordance with EN ISO 13855.
- ▶ Arrange the muting sensors so that material can pass unhindered but so no one can enter the hazardous area by fulfilling the muting conditions themselves (i.e., by activating both muting sensors and thereby meeting the muting requirements).

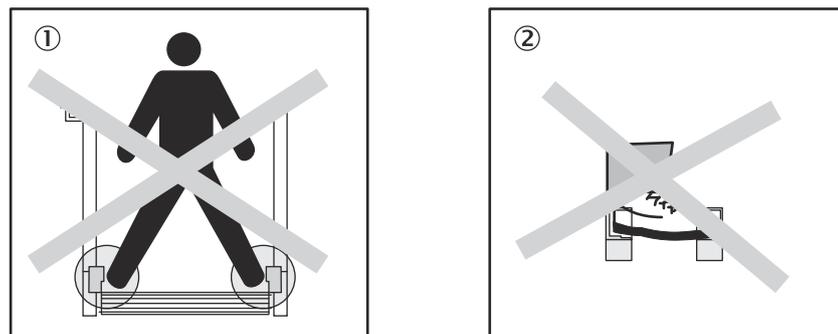

Figure 7: Safety requirements when mounting the muting sensors

- ① It must not be possible to activate sensors that are located opposite one another at the same time.

- ② It must not be possible to activate sensors that are located next to one another at the same time.

- ▶ Arrange the muting sensors so that only the moving material is detected, and not the transportation equipment (pallet or vehicle).

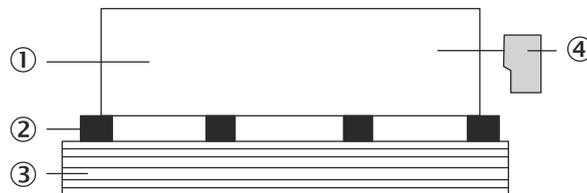

Figure 8: Detection of material during muting

- ① Transported material
- ② Transportation equipment
- ③ Transport level
- ④ Muting sensor

- ▶ Set up the muting so that the material to be transported is detected over the entire stretch. The output signals must not be interrupted.
- ▶ Arrange the muting sensors so that a minimum distance is observed in relation to the detection zone of the electro-sensitive protective equipment (e.g., in relation to the light beams of a light curtain) whenever material is detected. The minimum distance ensures the required processing time until muting is activated.

Safety notes for override

- ▶ Mount the control switches for the Override functions outside of the hazardous area so that they cannot be actuated by anyone who is located inside the hazardous area. In addition, the operator must have a complete overview of the hazardous area when actuating a control switch.
- ▶ Before activating the Override function, make sure that the equipment is in perfect working order, particularly the muting sensors (visual inspection).
- ▶ Make sure that the hazardous area is clear of people both before the Override function is activated and while it is active.
- ▶ If you have had to activate the Override function, check the functionality of the equipment and the arrangement of the muting sensors after the event.

Safety notes for the muting/override lamp

- ▶ Use a muting and/or override lamp to signal that the Muting or Override functions are active. You can either use an external muting/override lamp or one that is integrated into the electro-sensitive protective device (ESPE).
- ▶ Always attach the muting and/or override lamps so that they are clearly visible. The muting/override lamp must be visible from every side all the way around the hazardous area and must be clearly visible to the system operator.
- ▶ Depending on local, regional, and national regulations and standards, it may be necessary to monitor the muting/override lamp(s). If this is the case, implement additional measures for this purpose.

Further topics

- ["Notes on wiring", page 27](#)

4.4.2 Overview and general description

Muting is an automated process that temporarily bypasses safety functions of a control system or protective equipment. Muting allows certain objects (e.g., pallets loaded with material) to pass through electro-sensitive protective equipment (ESPE) such as a safety light curtain and into a hazardous area. During this transport operation, the Muting function bypasses monitoring by the electro-sensitive protective equipment.

Three different function blocks are available for muting:

- Parallel muting

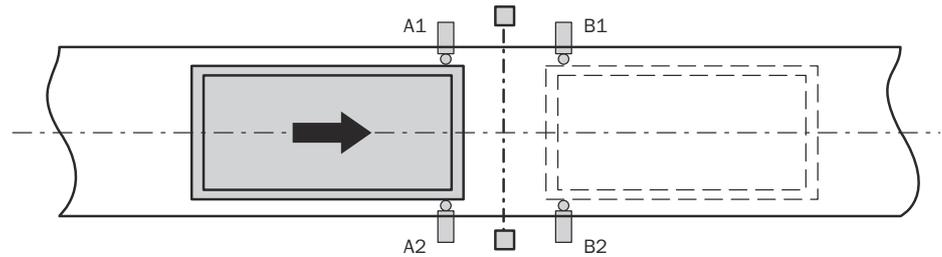

Figure 9: Muting with two sensor pairs arranged in parallel (A1 / A2 and B1 / B2)

- Sequential muting

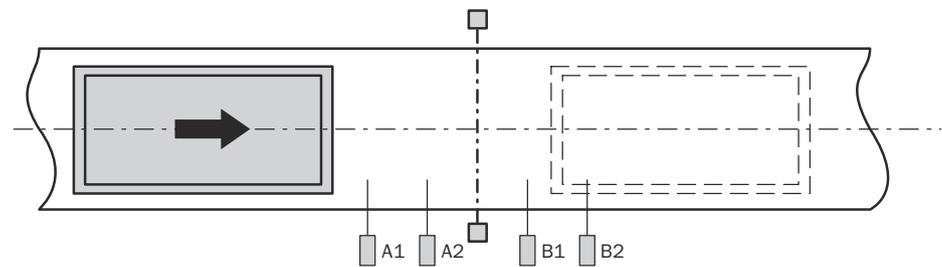

Figure 10: Muting with two sensor pairs arranged in sequence (A1 / A2 and B1 / B2)

- Cross muting

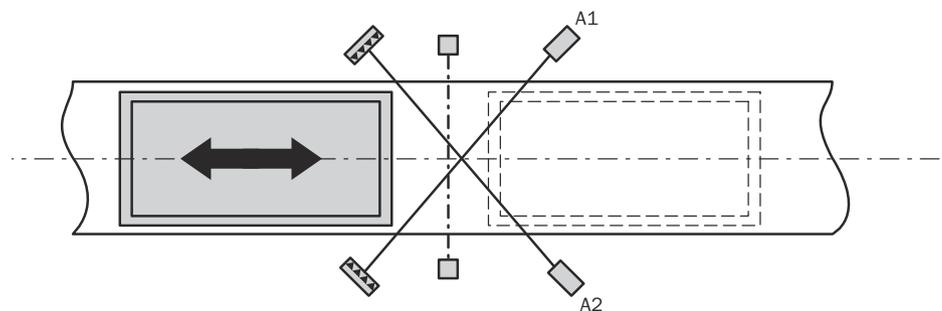

Figure 11: Muting with a sensor pair arranged crosswise (A1 / A2)

Muting sensors

Muting sensors monitor the presence of the material while it is being transported. Careful selection of the sensor type and how the sensors are arranged makes it possible to distinguish between objects and people.

In conjunction with the muting sensors and the electro-sensitive protective device, the object that is being transported generates a precisely defined signal sequence while it is traveling into the hazardous area. The muting sensors must ensure that all dangers are eliminated in the event of someone entering the area protected by the electro-sen-

sitive protective device (i.e., a dangerous state must be terminated immediately). It is absolutely essential to ensure that a person cannot generate the same signal sequence as a transported object.

The placement of the muting sensors is determined by the shape of the object being detected. There are various options involving different numbers of sensor input signals. These include the following:

- Two sensors
- Two sensors and one additional C1 signal
- Four sensors (two pairs of sensors)
- Four sensors (two pairs of sensors) and one additional C1 signal

Muting signals can be generated by the following sources:

- Optical sensors
- Inductive sensors
- Mechanical switches
- Controller signals

If optical sensors are used for muting applications, choose sensors with background suppression to ensure that only the material being transported fulfills the muting conditions. These sensors are only capable of detecting material up to a certain distance. Consequently, the input conditions for the muting sensors cannot be met by objects that are located any further away than this. This applies in particular to sequential muting.

Conditions for muting

While the muting status is active, the **Enabled** output remains at 1, even if the **Electro-sensitive protective device** input switches to 0.

Depending on the selected muting type and configuration, different conditions are tested for a correct muting cycle, i.e., the correct initiation, maintenance and termination of the muting status.

In general, at least one muting sensor signal pair (**A1/A2** or **B1/B2**) must always be active to maintain the muting status.

You can achieve a higher level of safety and improved protection against manipulation using the following functions:

Table 4: Monitoring functions for muting

Monitoring	Parallel muting	Sequential muting	Cross muting
Sequence monitoring	–	✓	–
Direction detection	✓	✓	–
C1 input	✓	✓	✓
Concurrency monitoring time	✓	✓	✓
Total muting time	✓	✓	✓
With electro-sensitive protective device	✓	✓	✓

Calculation of the distance L_1 for parallel muting

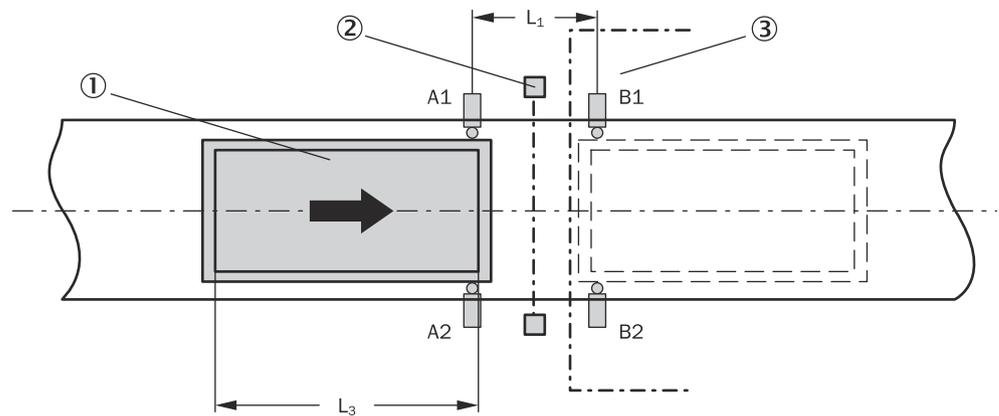

Figure 12: Example for parallel muting

- ① Transported material
- ② Electro-sensitive protective device (e.g., safety light curtain)
- ③ Hazardous area

In this example, the material moves from left to right. As soon as the first pair of muting sensors (A1 and A2) is activated, the protection afforded by the protective equipment (electro-sensitive protective equipment) is bypassed.

In the example, four muting sensors with identical response times are used. The two muting sensor pairs are mounted symmetrically, i.e., at the same distance from the detection range of the ESPE. Different configurations require separate consideration.

The distance L_1 is calculated using the following formula:

$$L_1 \geq v \times 2 \times T_{IN \text{ muting sensor}}$$

The following prerequisites must be met:

- $v \times t > L_1 + L_3$
- $L_1 < L_3$

L_1	Distance between the sensors (arranged symmetrically in relation to the detection zone of the electro-sensitive protective device)
L_3	Length of the material in the conveying direction
v	Speed of the material (e.g., of the conveyor system)
t	Configured total muting time (s)
$T_{IN \text{ muting sensor}}$	Response time of the slowest muting sensor used to initiate a muting status.

- The material can either be moved in both directions or only one transport direction can be allowed using the **Direction detection** configuration parameter.
- When the sensors are arranged in parallel, the position of the muting sensors is also used to monitor the width of the permissible object. Whenever objects move past the muting sensors, the width must always be the same.
- If optical sensors are used for parallel muting, pushbuttons with background suppression are typically used here to prevent a person from unintentionally activating both sensors at the same time.
- Prevent mutual interference of the sensors.

Calculation of the distance L_1 for sequential muting

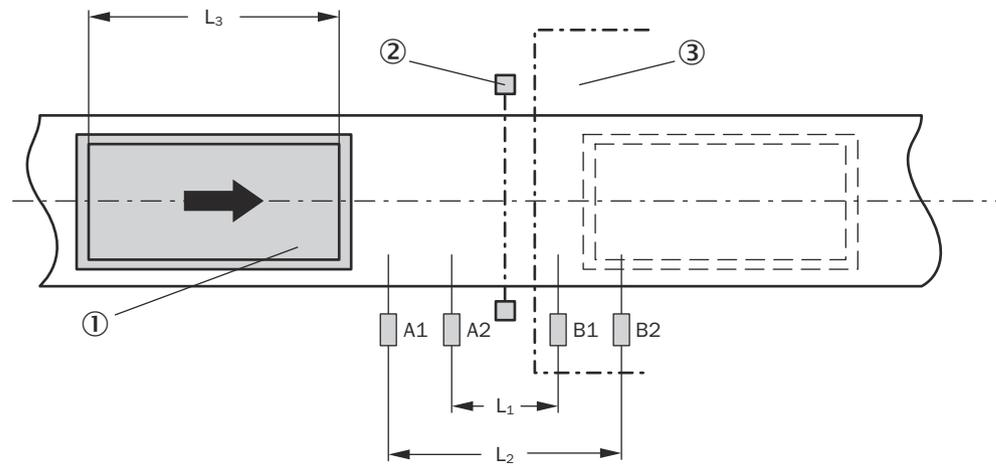

Figure 13: Example for sequential muting

- ① Transported material
- ② Electro-sensitive protective device (e.g., safety light curtain)
- ③ Hazardous area

In this example, the material moves from left to right. As soon as muting sensors A1 and A2 are activated, the protection afforded by the protective equipment (electro-sensitive protective equipment) is bypassed.

In the example, four muting sensors with identical response times are used. The two muting sensor pairs are mounted symmetrically, i.e., at the same distance from the detection range of the ESPE. Different configurations require separate consideration.

The distance L_1 is calculated using the following formula:

$$L_1 \geq v \times 2 \times T_{\text{IN muting sensor}}$$

The following prerequisites must be met:

- $v \times t > L_1 + L_3$
- $L_2 < L_3$

L_1	Distance between the inner sensors (arranged symmetrically in relation to the detection zone of the electro-sensitive protective device)
L_2	Distance between the outer sensors (arranged symmetrically in relation to the detection zone of the electro-sensitive protective device)
L_3	Length of the material in the conveying direction
v	Speed of the material (e.g., of the conveyor system)
t	Configured total muting time (s)
$T_{\text{IN muting sensor}}$	Response time of the slowest muting sensor used to initiate a muting status.

- The material can either be moved in both directions or only one transport direction can be allowed using the **Direction detection** configuration parameter.
- The sensor arrangement shown in this example is suitable for all types of sensor.
- Prevent mutual interference of the sensors.

Calculation of the distance L_1 for cross muting

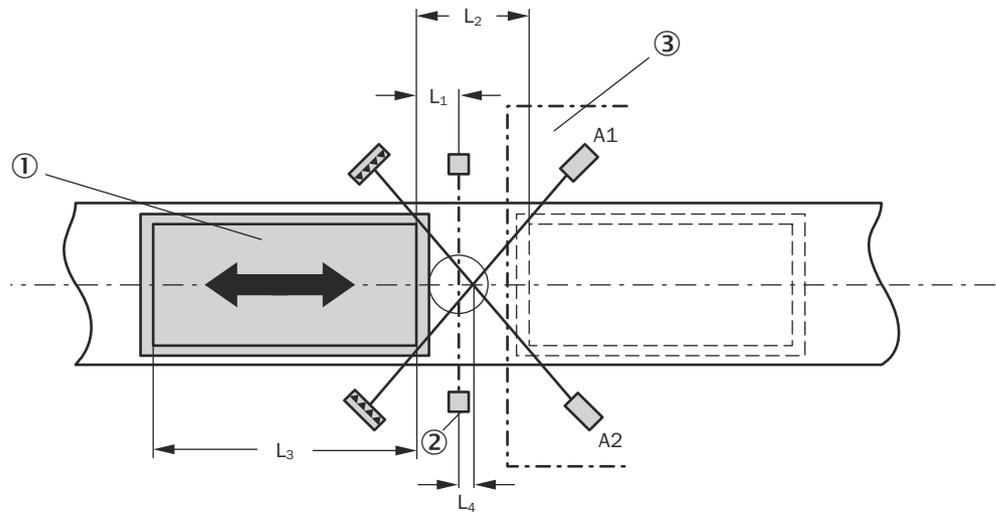

Figure 14: Example for cross muting

- ① Transported material
- ② Electro-sensitive protective equipment (e.g., safety light curtain)
- ③ Hazardous area

In this example, the material can move in both directions. As soon as the pair of muting sensors (A1 and A2) is activated, the protection afforded by the protective equipment (electro-sensitive protective equipment) is bypassed.

The distance L_1 is calculated using the following formula:

$$L_1 \geq v \times T_{IN \text{ muting sensor}}$$

The following prerequisites must be met:

- $v \times t > L_2 + L_3$
- $L_4 \geq 0$

L_1	Minimum distance between the detection line of the ESPE and detection by A1 and A2
L_2	Distance between the two detection lines of the A1 and A2 sensors (sensors activated/sensors clear)
L_3	Length of the material in the conveying direction
L_4	Distance between the detection line of the ESPE and the point where the muting sensors intersect
v	Speed of the material (e.g., of the conveyor system)
t	Configured total muting time (s)
$T_{IN \text{ muting sensor}}$	Response time of the slowest muting sensor used to initiate a muting status.

- In this example, the material is able to flow in both directions.
- The point where the muting sensors intersect should be placed behind the light beams of the ESPE in the hazardous area. If this is not possible, the point of intersection may be placed exactly in the path of the ESPE light beams, but not in front of it.
- The sensor arrangement shown in the example is suitable for through-beam photoelectric sensors and for photoelectric retro-reflective sensors.
- Prevent mutual interference of the sensors.

Further topics

- "Notes on wiring", page 27
- "Parallel muting V1", page 96
- "Sequential muting V1", page 99
- "Cross muting V1", page 102

4.4.3 Notes on wiring

If muting functions are to be implemented, potential errors must be taken into account as part of the wiring process. If certain signal combinations are to be transmitted via the same cable, additional precautions must be taken to ensure that the respective signals are correct. Suitable measures must be implemented (e.g., protected cable laying) to make sure that no errors can occur as a result of this wiring.

Table 5: Muting wiring combinations and requirements

Signal	A1	A2	B1	B2	C1	Conveyor	Electro-sensitive protective device	Override	Enabled	Muting lamp	Muting status	Override required
A1	-	A	B	B	A	A	A	A	A	A	A	C
A2	A	-	B	B	A	A	A	A	A	A	A	C
B1	B	B	-	A	A	A	A	A	A	A	A	C
B2	B	B	A	-	A	A	A	A	A	A	A	C
C1	A	A	A	A	-	A	A	A	A	C	C	C
Conveyor	A	A	A	A	A	-	C	A	A	C	C	C
Electro-sensitive protective device	A	A	A	A	A	C	-	C	A	C	C	C
Override	A	A	A	A	A	A	C	-	A	A	C	A

- A** The specified signals may only be installed in the same cable if a short-circuit between these signals can be excluded, e.g., by means of protected cable laying.
- B** The specified signals may only be installed in the same cable if sequence monitoring is used or a short-circuit between these signals can be excluded, e.g., by means of protected cable laying.
- C** The specified signals may be installed in the same cable.
- Not applicable

Short-circuit to 24 V supply voltage

If a short-circuit to High (to 24 V DC) occurs at a physical input, the evaluated signal may produce a pulse if the signal for **Override** is reset as a result of short-circuit detection.



WARNING

Undesired override following short-circuit to high

The dangerous state may not be stopped or not be stopped in a timely manner in the event of non-compliance.

- ▶ Make sure that the transitions of the signals that expect an input pulse (input for the muting function blocks) meet the requirements of safety standards and regulations.
 - ▶ Make sure the signal line is laid with protection (to prevent a cross-circuit with other signal lines)
 - ▶ No short-circuit detection, i.e., no referencing to test outputs

4.5 Electrical integration

4.5.1 Internal circuitry

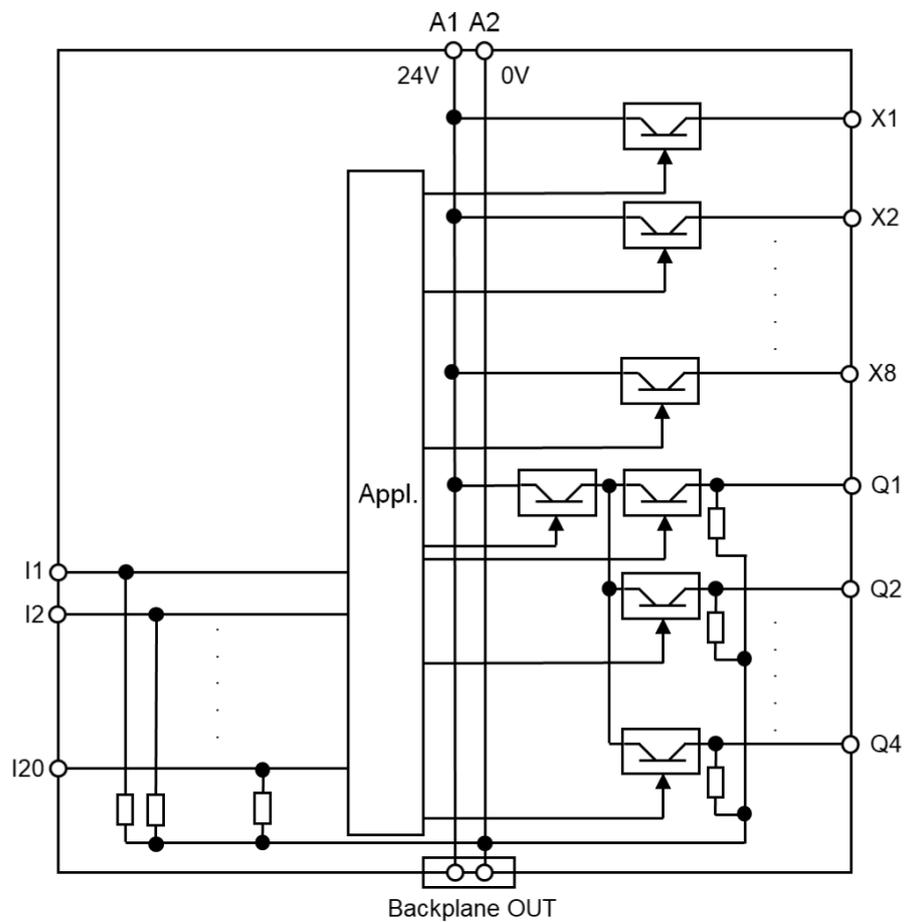

Figure 15: Internal circuitry main module

4.5.2 Fault detection using test outputs

Important information



WARNING

Unexpected pulses or delayed falling signal edges due to a short circuit
Machine can start up unexpectedly or the dangerous state of the machine may not be stopped or not stopped in a timely manner.

- ▶ Protect single-channel inputs against short-circuits and cross-circuits.
- ▶ Make sure the signal line is laid with protection (to prevent a cross-circuit with other signal lines).
- ▶ Take additional safety measures.

Prerequisites

- Use the test outputs of the module to which the device is connected.
- Use a permissible combination of safety capable inputs (I) and test outputs (X).
I.e. pairings with only an even-numbered or odd-numbered index, e.g. I1 and X1, I9 and X3, I20 and X4 ...

Fault detection by testing

The following faults can be detected by testing an element:

- Faults in electronic sensors with test inputs.
- Short-circuits between any of the test outputs.
Using a test pulse interval of ≥ 200 ms and a test pulse width of 2 ms, you can detect a cross-circuit between the test outputs of 12 sequential modules.
Using a test pulse interval of ≥ 8 ms and a test pulse width of 2 ms, you can detect a cross-circuit between any two sequential test output pairs of a module.
- Short circuits to 24 V DC (to High) on inputs that are connected to test outputs, regardless of the length of the test pulse width and the test pulse interval.
- Sensor wiring short-circuits to 24 V that could interfere with a switch-off condition.

The following faults cannot be detected:

- Short circuits between test outputs and the associated input.

Further topics

- ["Configuring elements", page 55](#)

4.5.3 Safety outputs

Important information



WARNING

Ineffectiveness of the protective device

In the event of a fault, a single safety output (Q) can switch off after a delay or briefly switch to High. The response time increases depending on the configuration of the output. The dangerous state may not be stopped or not be stopped in a timely manner in the event of non-compliance.

- ▶ Take the increased response time into consideration in the risk analysis.
- ▶ Take the possible reduced safety level into consideration in the risk analysis.

Fault detection by testing

The following faults can be detected by testing an element:

- Short-circuits between any of the safety outputs.

You can detect a cross-circuit between the safety outputs of 12 sequential modules.

- Short circuits to 24 V DC (to High) on safety outputs.
- Actuator wiring short-circuits to 24 V.

Further topics

- ["Front connector", page 38](#)
- ["Configuring elements", page 55](#)

4.5.4 Single-channel use of safety inputs

Important information



WARNING

Unexpected pulses or delayed falling signal edges due to a short-circuit to High Machine can start up unexpectedly or the dangerous state of the machine may not be stopped or not stopped in a timely manner.

- ▶ Protect single-channel inputs against short-circuits and cross-circuits.
 - ▶ Make sure the signal line is laid with protection (to prevent a cross-circuit with other signal lines).
 - ▶ Do not reference the test outputs.
-

Short-circuit to High for single-channel use of safe inputs

On a single-channel safety input with test pulses, which was previously in the low state, a short-circuit to high may be interpreted as a pulse by the logic due to the fault detection. The short-circuit to High causes the signal to switch to High and back to Low at the end of the fault detection time.

If a short-circuit to High occurs on a single-channel safety input with test pulses and this was already in the High state, the logic interprets the signal as a delayed falling signal edge (High - Low).

If a dangerous state could potentially arise because of an unexpected pulse or a delayed falling signal edge, then concrete measures must be implemented.

This is particularly important in the case of the following inputs:

- **Reset** input on the reset function block
- **Restart** input on the restart function block
- **Override** input on the muting function blocks
- **Reset to zero** input and **Set to reload value** input on a counter function block

4.6 Integration into the network

4.6.1 Network topology

The Modbus® TCP interface is suitable for the following network topologies:

- Star
- Tree

4.6.2 Integration via the fieldbus interface

Overview

You can connect the safety controller to a client as a server.

Prerequisites

- When integrating the system in Modbus® TCP: The Modbus®-TCP client can use the commands 03 (0x03) Read holding registers, 04 (0x04) Read input registers, and 16 (0x10) Write multiple registers.
- When integrating the system in SLMP: The SLMP client can use the commands 0x0613 Read memory, 0x1613 Write memory, and 0x0E30 Node search.

Parameters to be configured**Parameter:**

- Port used for SLMP
- Number of possible connections via Modbus® TCP

You can configure the parameters via the following interfaces:

- Safety Designer

4.7 Testing plan

Testing plan

The manufacturer of the machine and the operating entity must define all required thorough checks. The definition must be based on the application conditions and the risk assessment and must be documented in a traceable manner.

In addition, the device must be checked for correct functioning after each change to the configuration.

- ▶ When defining the thorough check, please note the following:
 - Define the type and execution of the thorough check.
 - Define the frequency of the thorough check.
 - Notify the machine operators of the thorough check and instruct them accordingly.

The following thorough checks are often defined in connection with a protective device:

- Thorough check during commissioning and modifications
- Regular thorough check

Thorough check during commissioning and modifications

Before commissioning the machine and after making changes, you must check whether the safety functions are fulfilling their planned purpose and whether persons are being adequately protected.

The following points are helpful when planning the thorough check:

- Does the thorough check have to be completed by qualified safety personnel?
- Can the thorough check be completed by personnel specially qualified and authorized to do so?
- Does the thorough check have to be documented in a traceable manner?
- Can the thorough check be carried out according to a check list?
- Do the machine operators know the function of the protective device?
- Have the machine operators been trained to work on the machine?
- Have the machine operators been notified about modifications to the machine?
- ▶ Define all guidelines for the thorough check.

Regular thorough check

The following points are helpful when planning the thorough check:

- Which thorough check must be carried out and how is it carried out?
 - How often does the thorough check have to be carried out?
 - Do the machine operators have to be notified of the thorough check and do they need to be instructed accordingly?
- ▶ Define all guidelines for the thorough check.

5 Mounting

5.1 Mounting procedure

Prerequisites

- Assembly is carried out according to the project planning.
- Dangerous condition of the machine is and remains switched off during mounting.
- The outputs of the safety controller do not affect the machine during mounting.

Approach

1. Attach main module to mounting rail.

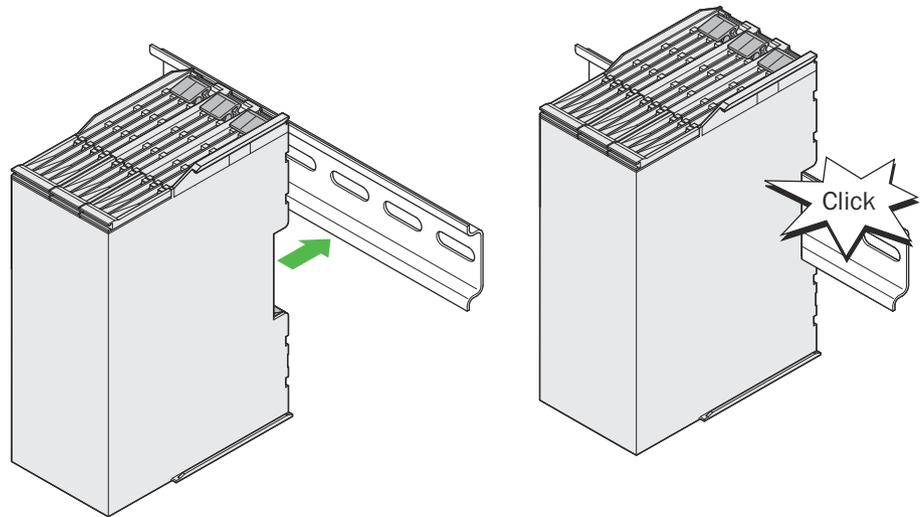

Figure 16: Main module mounting

- ✓ The main module engages with an audible click.
2. Attach the expansion module to the mounting rail. Ensure that the side guide rails of the module intertwine.

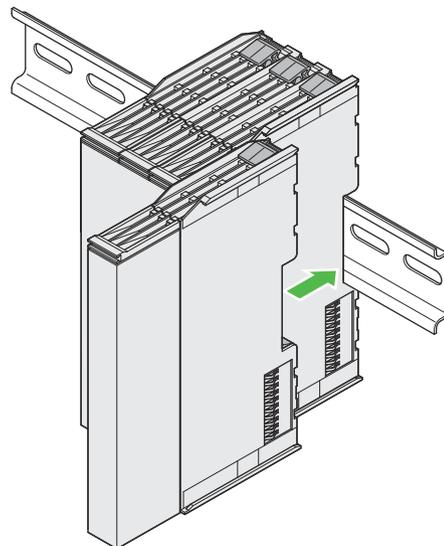
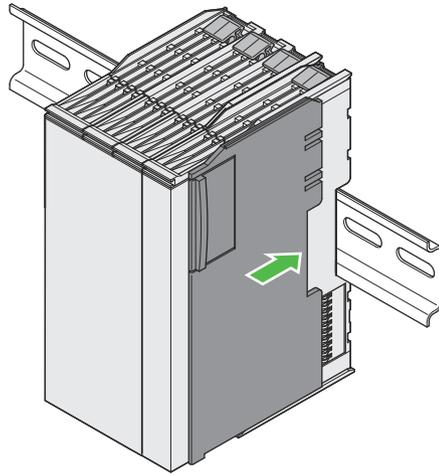

Figure 17: Expansion module mounting

- ✓ The module engages with an audible click.
3. Attach the housing end cap to the last module.



4. Attach the end clamps on the mounting rail on the left and right of the safety controller.

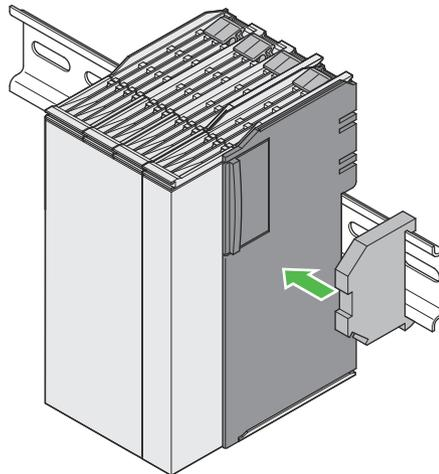

Figure 18: Housing end cap and end clamp mounting

Further topics

- ["Design", page 18](#)

5.2 Mounting the SmartPlug

Approach

1. Disconnect the main module and the components connected to the front connection from all voltage sources.
2. Push the front connector unlocking mechanism downwards and pull out the front connector.

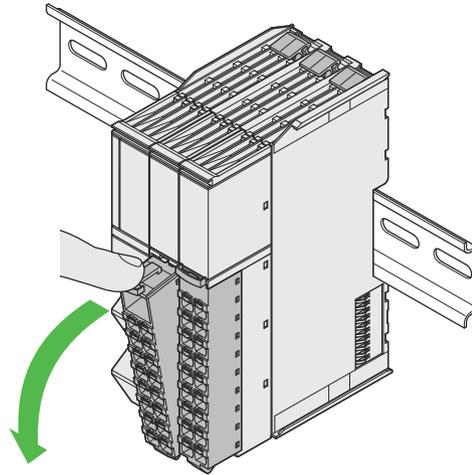
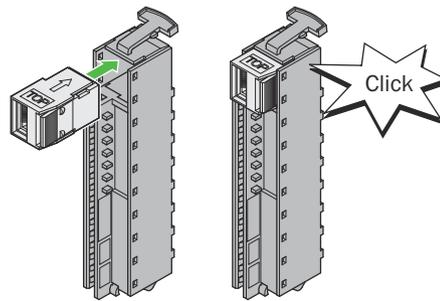

Figure 19: Pull out the front connector

3. Insert the SmartPlug into the rear side of the front connector.



4. First mount the terminal strip with bent hook in the module and then engage in the housing.
 ✓ The front connector engages with an audible click.

Further topics

- ["SmartPlug"](#)

5.3 Disassembly

Prerequisites

- Electrician screwdriver (slotted screwdriver)

Approach

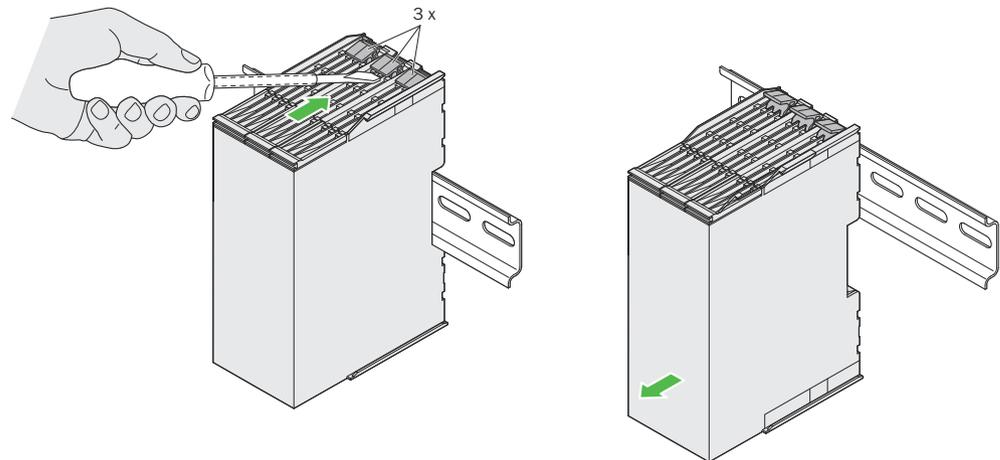

1. Disconnect the module and the connected components from all voltage sources.
2. Press the unlocking mechanism(s) on the upper side of the module towards the back using the electrician screwdriver.
3. Loosen the module from the mounting rail.
- ✓ The module is disassembled.
4. Press the unlocking mechanisms of the disassembled module forwards.

5.4 Module exchange

Approach

1. Disconnect module and the connected components from all voltage sources.
2. Take front connector with connected cables off the defective device: Press the unlocking mechanism of the front connector downwards and pull out the front connector.

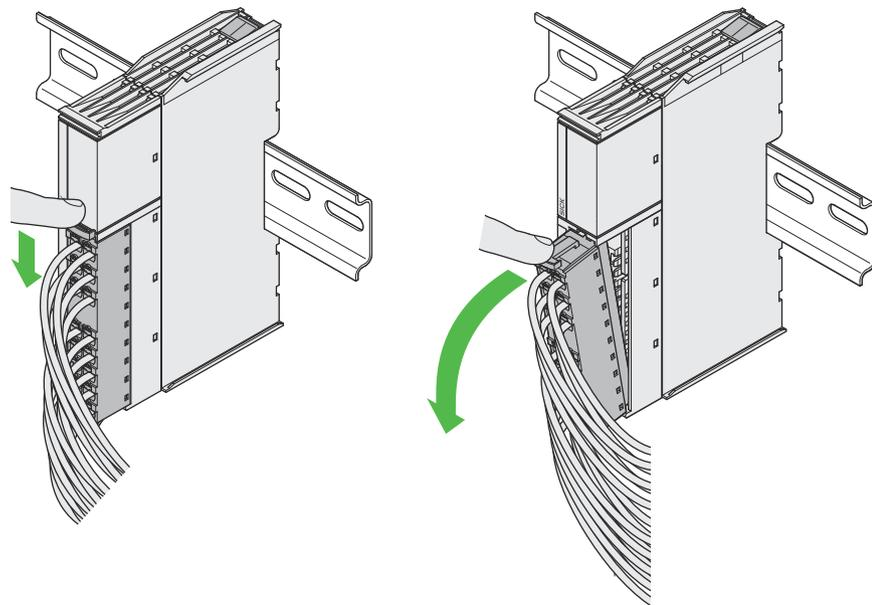

Figure 20: Dismantle front connector

3. Dismantle the defective module.
4. Mount new module.

5. Mount front connector with connected cables to the new module: First mount in the module with bent hook and then engage in the housing.

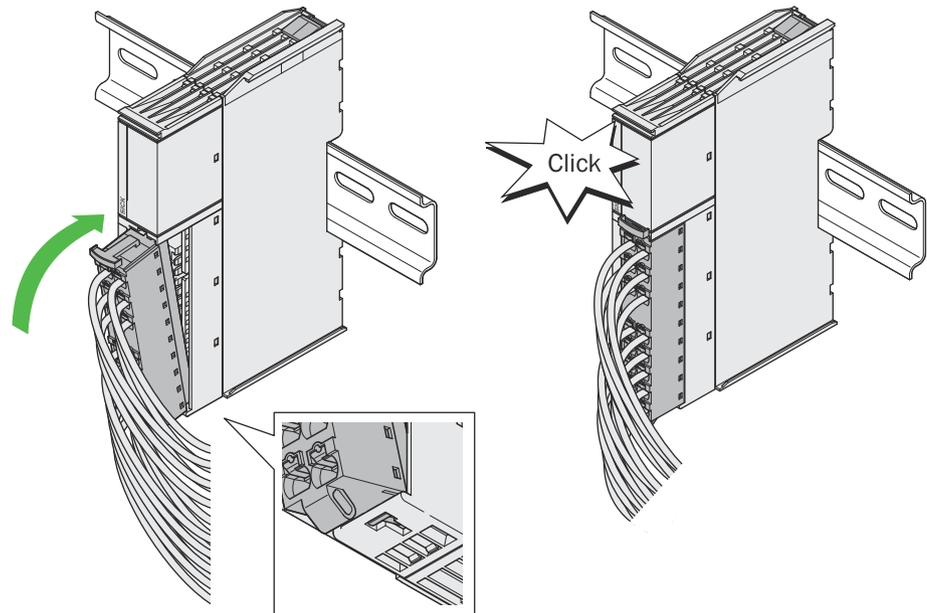

Figure 21: Mount the front connector

- ✓ The front connector engages with an audible click.

Further topics

- ["Mounting procedure", page 33](#)
- ["Disassembly", page 35](#)
- ["Offline, online and security configuration", page 45](#)

6 Electrical installation

6.1 Connecting

Prerequisites

- Mounting is completed.
- Electrical installation is carried out according to the project planning.
- Dangerous condition of the machine is and remains off during the electrical installation.
- The outputs of the safety controller do not affect the machine during electrical installation.

6.1.1 Front connector

Prerequisites

Electrical connection requirement:

- Electrical installation is performed in accordance with EN 60204-1.
- The mounting rail is connected to the functional earth.
- The voltage supply and connected signals meet the requirements for extra-low voltages with safe separation (EN 60664) or NEC Class 2 (UL 1310).
- The external voltage supply must be capable of buffering brief power failures of 20 ms as specified in EN 60204-1. Suitable power supply units are available as accessories from SICK.
- Galvanically isolate the battery-operated 24 V power circuit from the circuit of the safety controller using an enclosed DC-DC transducer in accordance with EN 1175 (e.g., when using on an automated guided vehicle).
- The GND of all connected devices must have the same potential as A2 of the main module. Exceptions are actuators which are connected to an expansion module with its own voltage supply.
- The GND connections of the actuators to the safety outputs are in star formation with the GND connection of the voltage supply.

Pin assignment

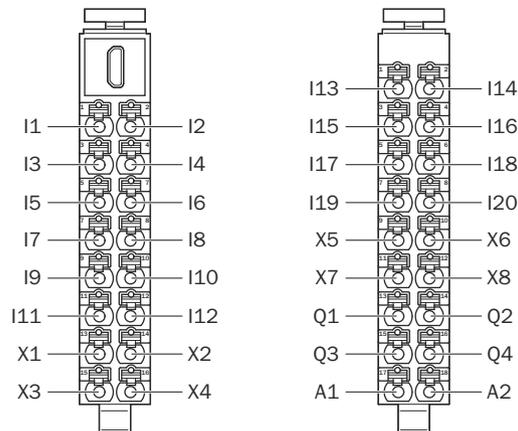

Figure 22: Terminals on front connectors

Table 6: Left front connector pin assignment

Terminal	Designation	Description
1	I1	Safety capable input
2	I2	
3	I3	
4	I4	
5	I5	
6	I6	
7	I7	
8	I8	
9	I9	
10	I10	
11	I11	
12	I12	
13	X1	Test output
14	X2	
15	X3	
16	X4	

Table 7: Right front connector pin assignment

Terminal	Designation	Description
1	I13	Safety capable input
2	I14	
3	I15	
4	I16	
5	I17	
6	I18	
7	I19	
8	I20	
9	X5	Test output
10	X6	
11	X7	
12	X8	
13	Q1	Safety output
14	Q2	
15	Q3	
16	Q4	
17	A1	24 V
18	A2	GND

Complementary information

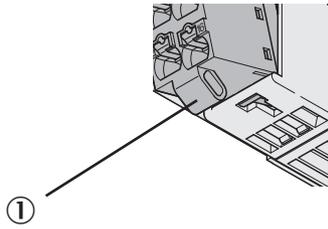

Figure 23: Eyelet on front connector

- ① Eyelet for cable tie

Connected cables can be fastened to the front connector eyelet using a cable tie. This relieves the strain on the cables.

Further topics

- ["Electrical integration", page 28](#)

6.1.2 RJ45 port connection

Prerequisites

Network cable requirement:

- Type: 100Base-TX
- Cables with RJ45 connections
- Twisted pair Ethernet cable, maximum length 100 m in accordance with EN 50173
- Use of wire pairs 1/2 and 3/6
- Shielded cables
- Cat 5 STP or higher

Connection

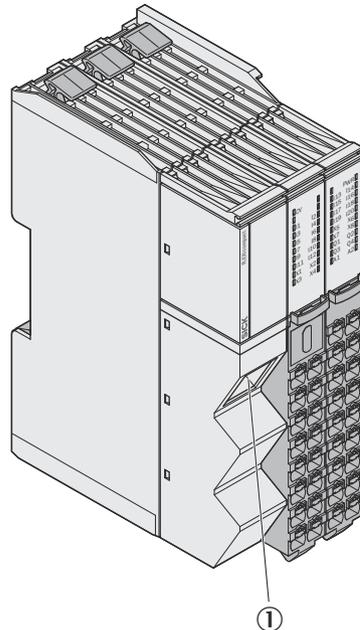

- ① RJ45 female Ethernet connector

6.2 Coding

Overview

You can code the front connector and its modules. A uniquely coded front connector only fits a uniquely coded module. Coding prevents the front connectors from getting mixed up.

Coding options

- 1-of-7 coding: 7 front connectors can be uniquely coded.

	Coding						
	1	2	3	4	5	6	7
Front connector 1	<input type="checkbox"/>	■	■	■	■	■	■
Front connector 2	■	<input type="checkbox"/>	■	■	■	■	■
...				...			
Front connector 7	■	■	■	■	■	■	<input type="checkbox"/>

- 2-of-7 coding: 21 front connectors can be uniquely coded.

	Coding						
	1	2	3	4	5	6	7
Front connector 1	<input type="checkbox"/>	<input type="checkbox"/>	■	■	■	■	■
Front connector 2	■	<input type="checkbox"/>	<input type="checkbox"/>	■	■	■	■
...				...			
Front connector 6	■	■	■	■	■	<input type="checkbox"/>	<input type="checkbox"/>
Front connector 7	<input type="checkbox"/>	■	■	■	■	■	<input type="checkbox"/>
...				...			

- 3-of-7 coding: 35 front connectors can be uniquely coded.

	Coding						
	1	2	3	4	5	6	7
Front connector 1	<input type="checkbox"/>	<input type="checkbox"/>	<input type="checkbox"/>	■	■	■	■
Front connector 2	■	<input type="checkbox"/>	<input type="checkbox"/>	<input type="checkbox"/>	■	■	■
...				...			
Front connector 5	■	■	■	■	<input type="checkbox"/>	<input type="checkbox"/>	<input type="checkbox"/>
Front connector 6	<input type="checkbox"/>	<input type="checkbox"/>	■	■	■	■	<input type="checkbox"/>
...				...			

6.2.1 Coding front connector and module

Prerequisites

- Slotted screwdriver 3.5 mm × 0.6 mm
- Diagonal cutter

Approach

Each front connector contains seven coding ribs. The modules have seven coding elements each for each front connector.

1. Remove the coding ribs on the front connector with wire cutters.

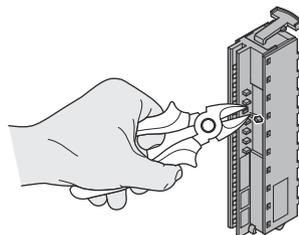

2. Insert the slotted screwdriver vertically on the left next to the respective coding element.

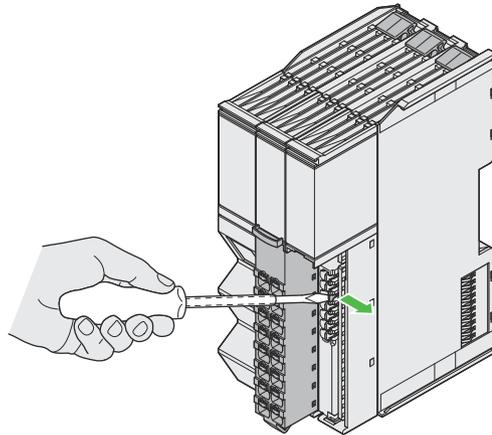

3. Tip the coding element to the right with a slotted screwdriver.
✓ The coding element engages.

Complementary information

You can not reattach a removed coding rib to the front connector.

If you turn a coding element on a module several times, it can break off. This means there is no active coding function in this case. However, you can continue to use the module.

7 Configuration

7.1 Delivery state

The device is not configured in the delivery state.

7.2 Safety Designer configuration software

The safety controller is configured using the Safety Designer configuration software.

For information on the Safety Designer, see the operating instructions for the Safety Designer item no. 8018178.

7.2.1 User interface

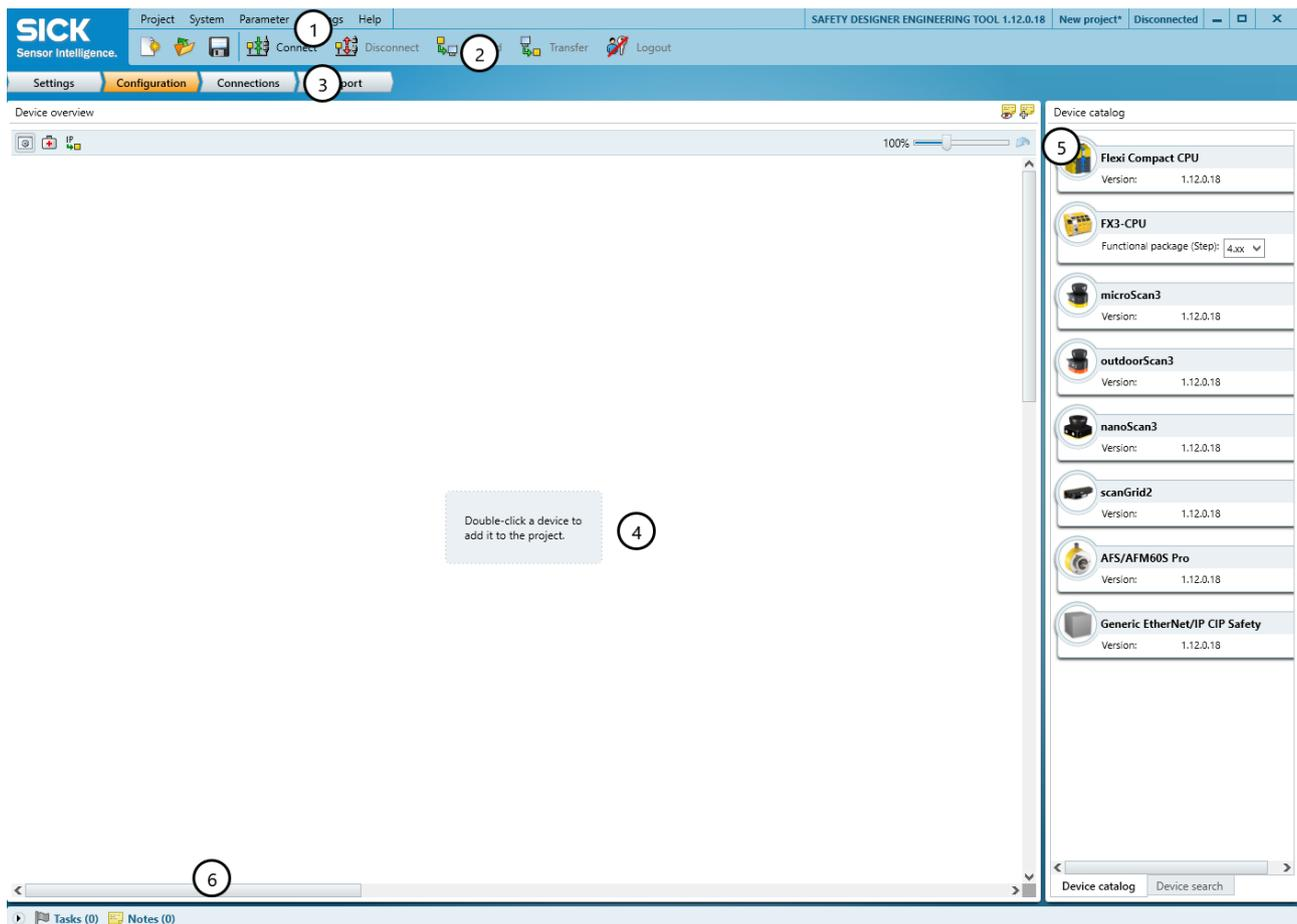

Figure 24: Software controls

- ① Menu bar
- ② Toolbar
- ③ Main navigation
- ④ Working range
- ⑤ Device catalog
- ⑥ Task list and notes

7.2.2 User groups

Overview

The devices contain a hierarchy of user groups that regulate access to the devices.

For certain actions (e.g., transferring a configuration to the device), you are requested to log onto the device with the respective user group.

Important information



NOTICE

When you log into a device, the configuration software stores the password so that you do not need to re-enter it for other configuration steps.

If you do not change any other settings in the login dialog, the password is deleted as soon as you exit the configuration software, or log out in the main window or Device window.

If you enable the **Temporarily store password for login on additional devices.** function, the password will be retained even if you log out in the device window only.

If you leave the computer unattended, you must log off to prevent unwanted access to the device.

User groups

Table 8: User groups

User group	Password	Authorization
 Operator	No password required. Anyone can log on as a machine operator.	<ul style="list-style-type: none"> • May read configuration from the device.
 Maintenance personnel	Deactivated ex-works, i.e. it is not initially possible to log on as a maintenance technician. The user group can be activated by the user group administrator and provided with a password.	<ul style="list-style-type: none"> • May read configuration from the device. • May transmit verified configuration to the device. • Change own password allowed.
 Authorized client	Deactivated ex-works, i.e. it is not initially possible to log on as an authorized customer. The user group can be activated by the user group administrator and provided with a password.	<ul style="list-style-type: none"> • May read configuration from the device. • May transmit verified and unverified configuration to the device. • May verify configuration. • Resetting the safety function and communication settings to factory defaults is allowed. • Change own password allowed. • Changing the password of the Maintenance personnel user group is allowed.

User group		Password	Authorization
	Administrator	<p>The password SICKSAFE is created at the factory.</p> <ul style="list-style-type: none"> ► Change this password to protect the device against unauthorized access. 	<ul style="list-style-type: none"> • May read configuration from the device. • May transmit verified and unverified configuration to the device. • May verify configuration. • Resetting whole device to factory settings allowed. • Activating and deactivating device functions is allowed. • Activating and deactivating the Maintenance personnel and Authorized client user groups is allowed. • Change own password allowed. • Changing the passwords of the Maintenance personnel and Authorized client user groups is allowed.

Complementary information

The configuration of the device is saved in the system plug. Therefore, the passwords are retained when the device is replaced if the system plug is still used.

7.3 Offline, online and security configuration

Overview

All configuration parameters are assigned to a configuration group. The configuration groups differ, for example, when transmitting and saving the configuration.

The following configuration groups are available

- Offline configuration
- Online configuration
- Security configuration

Offline configuration

All offline configuration parameters are written to the safety controller using the **Transfer to device** function. The offline configuration includes, for example, all parameters of the hardware configuration.

These parameters can only be configured in the configuration software.

To configure the parameters, no connection to the safety controller must exist. Only establish a connection to the safety controller when you want to transfer the configuration.

The application is stopped while the configuration is transferred to the safety controller.

The offline configuration is stored in the SmartPlug. A (defective) module can be replaced with a compatible module without having to reconfigure the device. The offline configuration must be compatible with the physical safety controller.

Within the offline configuration, a distinction is made between the following configuration data.

Configuration data:

- Safety configuration
Configuration data that affect the safety function of a device, e.g., configuration of safety capable inputs, safety outputs, logic, ...
- Standard configuration

Configuration data that affect the non-safety function of a device, e.g., configuration of test outputs, configuration of non-safe modules.

- Non-functional configuration
Configuration data that have no effect on the functioning of the device, e.g. tag names, comments in the logic, project information of the user

Online configuration

Each of the online configuration parameters have their own transfer option and can be individually written to the safety controller. The online configuration includes, for example, the parameters relating to the network settings.

These parameters can be configured in the configuration software or via a module with a display.

To configure the parameters using the configuration software, a connection to the safety controller must exist.

The application does not need to be stopped while the configuration is transferred to the safety controller.

The online configuration is saved in and read back from the SmartPlug using the module position and the module type. If the module position is maintained, a (defective) module can be replaced with a compatible module without having to reconfigure the device. If the module position is changed, the saved parameters will not work. If, for example, the module position of a gateway is changed, the connection parameters need to be reconfigured before a connection to the safety controller can be established. The old module positions are corrected when writing an offline configuration.

If online configuration parameters are configured without a SmartPlug inserted, these settings will only apply temporarily until the safety controller is restarted or a SmartPlug is inserted.

Security configuration

The security configuration includes the following parameters:

- Passwords for user groups

These parameters can only be configured in the configuration software.

The application does not need to be stopped while the configuration is transferred to the safety controller.

The security configuration is saved in the SmartPlug. A (defective) module can be replaced with a compatible module without having to reconfigure the device.

Further topics

- ["SmartPlug", page 16](#)

7.4 Overview main navigation menu

The **Overview** main navigation menu contains information about the configuration.

7.5 Configuration main navigation menu

Configuration main navigation menu

Once a main module has been selected in the configuration software, the various modules and connectable elements can be combined into a safety controller.

- **Hardware configuration:** This is where you combine the modules and elements into a safety controller.
- **Catalog :** This is where you select the modules and elements and, if necessary, configure your own elements.
- In the Navigation pane, you can switch between the **Hardware configuration**, the **BOM info**, and the **Diagnostic bits** (online only) of the modules.
- **Move elements here and leave for later use.:** Here you can create a collection of devices for a specific application and store them here temporarily.
- Modules or elements can be deleted using the trashcan.

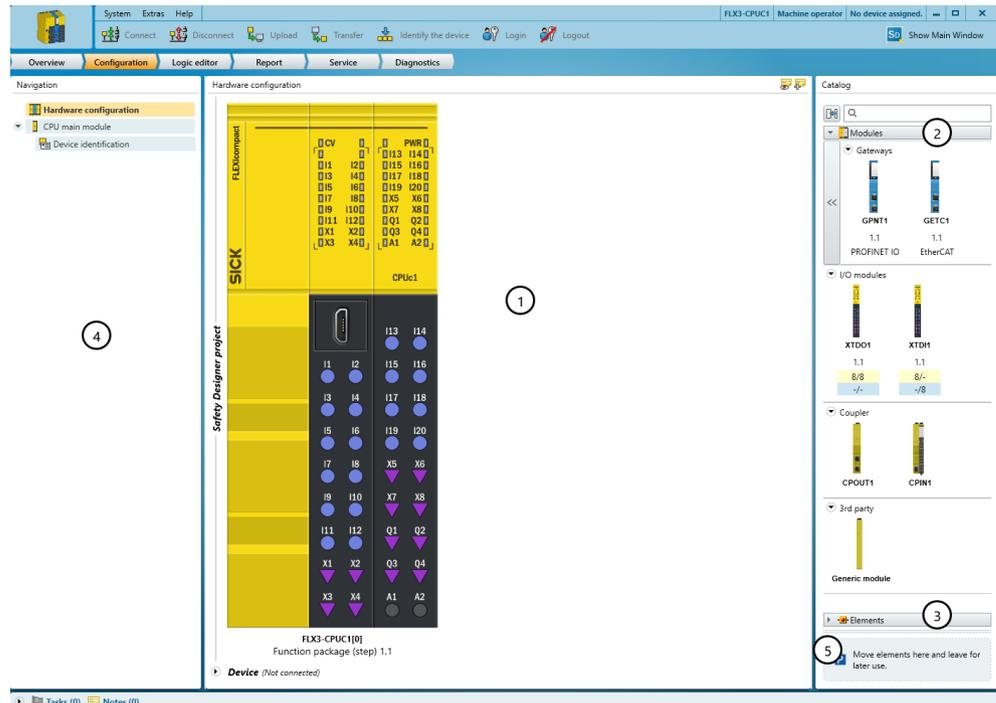

Figure 25: Configuration

- ① Workspace
- ② Module catalog
- ③ Element catalog
- ④ Navigation
- ⑤ Parking area

Complementary information

The **Edit mode** button is only visible if the configuration software is connected to a safety controller.

The configuration can be edited in **Edit mode** if the safety controller is online.



Figure 26: Edit mode button

7.5.1 Identification

Overview

On the **Identification** page, you can optionally enter attributes for the device. The attributes are used to identify the device or to distinguish between different devices. The attributes appear in reports and in the diagnostic data.

Device name

If a number of devices are used in an application or in a project, a unique device name helps to tell the individual devices apart.

Project name

The project name is used to identify an entire project. The same project name should be chosen for all devices in the project.

Application name

The application name can be the same for a number of devices in the project.

User name

The optional user name helps later users to find a contact for the application.

Application image

An image helps to identify the application more quickly. The application image is saved in the project file on the computer and transmitted to the device. The Safety Designer supports the following file formats: BMP, GIF, JPG, PNG, TIF.

Description

A description makes it easier to understand an application's context more quickly.

7.5.2 Protecting the configuration in the SmartPlug with a password

Approach

1. In the **Navigation** under **CPU main module**, click on **Password protection**.
2. Select the **Upload only as authorized client** option.

Complementary information

The password is stored in the SmartPlug. The password protection is therefore still effective if the main module is replaced.

7.5.3 Adding expansion modules

Overview

The **Catalog** shows, in the **Modules** area, all expansion modules that can be added. A version can be selected for the module, if applicable.

Approach

1. In the **Navigation pane**, click on **Hardware configuration**.
 2. In the **Catalog** under **Modules**, select the version of an expansion module if applicable.
 3. Drag an expansion module in the **Catalog** to the desired position. Alternatively, double-click on an expansion module.
- ✓ The expansion module is added to the workspace.

7.5.4 Input elements

Table 9: Categories of input elements

Category	Details in the configuration software report			Examples
	Mode	Test pulses	Other parameters	
Electro-mechanical switch/safety switch (EMSS) Contract based single-channel/dual-channel electro-mechanical switch/safety switch without signal processing unit	<ul style="list-style-type: none"> Single-channel input Dual-channel equivalent input Dual-channel complementary input 	<ul style="list-style-type: none"> Without test pulse (deactivated) Test pulse width = 2 ms 		<ul style="list-style-type: none"> Magnetic safety switches Emergency stop pushbutton Reset switch Safety door limit switch Two-hand control devices Enabling pushbutton Operating mode selector switch
Safety sensors with monitored semiconductor output (OSSD) Safety sensors with dual-channel cross-circuit monitored semiconductor outputs	Dual-channel equivalent input	Without test pulse (deactivated)	OSSD test pulse filter active	<ul style="list-style-type: none"> Transponder safety switch e.g., Sistra Safety light curtain e.g., deTec4 Safety laser scanner e.g., microScan3, nanoScan3
Safety sensors with test input Safety sensors with a test input, signal processing unit and test output	Single-channel input	Test pulse width ≥ 4 ms		<ul style="list-style-type: none"> Type 2/4 safety photoelectric sensor e.g., L41 Flexi Loop
Safety pressure mats ¹⁾²⁾	Dual-channel input with short-circuit detection (with/without diodes)	Test pulse width ≥ 2 ms		<ul style="list-style-type: none"> Safety pressure mats Edges and bars

1) When sensor cables carry the test pulse signal of the same test output, protected or separate cabling is required. Reason: Cross-circuits between the sensor cables are not detected.
 2) If you are configuring safety pressure mats (dual-channel input with short-circuit detection), the safety function must be requested at least once a year.

7.5.4.1 Configuration options for input elements

Important information



DANGER

Ineffectiveness of the protective device or reduction of the safety parameters due to a change in configuration of the element

The dangerous state may not be stopped or not be stopped in a timely manner in the event of non-compliance.

- ▶ Take longer response times, fault detection times or reduced safety parameters into account.



WARNING

Ineffectiveness of the protective device due to longer response time with debounce filter

The dangerous state may not be stopped or not be stopped in a timely manner in the event of non-compliance.

- ▶ Select the shortest possible debounce time.
- ▶ Take into account the longer response time.

Configuration options for input elements

Table 10: Configuration options for input elements

Parameter	Description
Tag name	The logic editor and report display the tag name of an element.
Nr. of devices:	If multiple devices are connected in a safe series connection, you can enter the number of devices here.
Safety element	Specifies whether you can use the element for a safety function.
ON-OFF	The ON-OFF debounce filter for falling signal edges (1 → 0) and the OFF-ON debounce filter for rising signal edges (0 → 1) prevent undesirable signal changes that arise as a result of bouncing of the contacts. When the debounce filter is active, a change in the signal is delayed by the selected debounce filter time [ms]. Take into account the longer response time.
OFF-ON debounce filter	
Debounce filter time	
Element is connected to a test output	The element is tested if the option is activated. You can configure the test pulse interval and test pulse width in the Test outputs tab.
test pulse interval (test pulse interval)	For dual-channel elements, these parameters can be configured individually for each channel.
test pulse width (test pulse width)	
Discrepancy time	The discrepancy time determines how long the two inputs can continue to have different values after the value of one of the two input signals changes.
OSSD test pulse filter	When this option is activated, the device filters out test pulses from safety sensors with self-testing semiconductor outputs (OSSD) that have a test pulse width of ≤ 1 ms. No lengthening of the response time needs to be taken into consideration.
Max. tolerated test pulse delay	The max. tolerated test pulse delay specifies how long safety sensors with test inputs can delay the signal of a test output (X) before the safety capable input no longer detects it. <ul style="list-style-type: none"> For safety sensors with test inputs: If the configured test pulse interval is > 8 ms and a long delay time of the test signal due to the connected sensors is expected, e.g., when cascading the sensors, set this to 12 ms. See the operating instructions of the sensor In all other cases and for all other sensors: Always use 0 ms Take into account the longer response time.

Further topics

- ["Discrepancy time", page 50](#)
- ["Maximum response time", page 135](#)
- ["Data sheet", page 130](#)
- ["Report main navigation menu", page 115](#)

7.5.4.2 Discrepancy time

Overview

The safety controller evaluates dual-channel elements with or without a discrepancy time. The discrepancy time determines how long the two inputs can continue to have different values (for dual channel equivalent mode) or the same value (for dual-channel complementary mode) after the value of one of the two input signals changes.

Discrepancy conditions for equivalent and complementary evaluation

Table 11: Dual-channel evaluation

Mode	Input A	Input B	Discrepancy timer ¹⁾	Status of dual-channel evaluation	Input in the logic editor	Discrepancy error
Dual channel equivalent	0	0	0	Deactivated	0	0
	0	1	< discrepancy time	Discrepant	0	Unchanged ²⁾
	1	0	< discrepancy time	Discrepant	0	Unchanged ²⁾
	1	1	0	Active ³⁾	1	0
	X	X	≥ discrepancy time (timeout)	Error	0	1
Dual channel complementary	0	1	0	Deactivated	0	0
	0	0	< discrepancy time	Discrepant	0	Unchanged ²⁾
	1	1	< discrepancy time	Discrepant	0	Unchanged ²⁾
	1	0	0	Active ³⁾	1	0
	X	X	≥ discrepancy time (timeout)	Error	0	1

1) Discrepancy time activated: The discrepancy timer starts on the first signal change that leads to a discrepant status.

Discrepancy time deactivated: The discrepancy timer is inactive. No timeout ever occurs.

2) Unchanged = the last status is retained.

3) If the dual-channel element adheres to the correct sequence.

Sequence error

A dual-channel evaluation can only switch to Active (input changes in the logic from 0 to 1) if the following conditions are met:

- The status was set to Deactivated at least once since it was last Active, i.e., it is not possible to switch from Active to Discrepant and then back to Active.
- The discrepancy time has either not yet elapsed or is deactivated.

If the correct sequence for achieving the Active status has not been observed, the safety controller indicates a sequence error within a maximum of 100 ms.

Complementary information

Value range: 0 ms ... 60 s

- When **Discrepancy time** is deactivated, the value is set to infinite.
- If signals from tested sensors are connected, the discrepancy time must be greater than the test pulse width (ms) + the max. tolerated test pulse delay (ms) of the safety input used.
- A discrepancy error (timeout) is reset when the Disabled status is achieved.

Further topics

- ["Possible faults", page 125](#)

7.5.4.3 Start - Automatic selection of reset mode

Overview

You can use the **Automatic selection of reset mode** input element in combination with the **Reset V1** function block to perform a restart. Connect the safety input to the **Reset** input of the function block.

Depending on the wiring of the input, the reset function goes into the corresponding operating mode when the logic program is started. This results in different behavior without changing the logic program, only by changing the hardware connection.

Operating modes:

- Mode with restart interlock: Manual reset
- Mode without restart interlock: Automatic reset

Important information



WARNING

Unexpected machine start-up due to automatic reset without restart interlock

In the case of non-compliance, it is possible that the dangerous state of the machine may not be stopped or not stopped in a timely manner.

- ▶ Take other protective measures to make sure that there is no one inside the hazardous area.

Prerequisites

- **Reset V1** function block

Manual reset

For manual reset, a pushbutton is connected between the safety input and the supply voltage. Pressing the pushbutton manually for min. 100 ms triggers a valid reset sequence at the **Reset** input of the function block.

Automatic reset

With automatic reset, the safety input and the associated test output are connected with a wire jumper. There is no restart interlock. With a direct connection between the test output and the safety input, the input signal toggles (changes) periodically in the logic. This automatically triggers a valid reset sequence at the **Reset** input of the function block every 400 ms.

Further topics

- ["Front connector", page 38](#)
- ["Reset V1", page 88](#)

7.5.5 Output elements

Table 12: Categories of output elements

Category	Details in the configuration software report			Examples
	Mode	Test pulses	Other parameters	
Actuators/safe actuators	<ul style="list-style-type: none"> • Single-channel output (NPN) • Single-channel output (push-pull) • Single-channel output (PNP) • Dual-channel output 	<ul style="list-style-type: none"> • Without test pulse (deactivated) (note any further measures, if applicable) • With test pulses (note any further measures, if applicable) 	<ul style="list-style-type: none"> • Increased capacitive loads not allowed • Increased capacitive loads allowed 	<ul style="list-style-type: none"> • Safety relay, e.g., ReLy • Safety contactors • Safety locking devices, e.g., MLP1 • Valves • Motors • Robot • Lamps

7.5.5.1 Configuration options for output elements

Important information



DANGER

Ineffectiveness of the protective device or reduction of the safety parameters due to a change in configuration of the element

The dangerous state may not be stopped or not be stopped in a timely manner in the event of non-compliance.

- ▶ Take longer response times, fault detection times or reduced safety parameters into account.



WARNING

Reduced safety characteristics due to deactivation of the test pulses

In the case of non-compliance, it is possible that the dangerous state of the machine may not be stopped or not stopped in a timely manner.

- ▶ Use protected or separate cabling.
- ▶ Perform one of the following actions:
 - Restart the safety controller once a year.
 - Manually switch off all safety outputs simultaneously for min. 2 s once a year. The supply voltage to the outputs must be within the operating range during this manual test.



WARNING

Ineffectiveness of the protective device due to longer fault detection time with the Increased capacitive loads allowed option.

In the case of non-compliance, it is possible that the dangerous state of the machine may not be stopped or not stopped in a timely manner.

The **Increased capacitive loads allowed** option results in a longer fault detection time. This primarily applies to single-channel outputs.

- ▶ Take into account the extended error detection time.

Configuration options for output elements

Table 13: Configuration options for output elements

Parameter	Description
Tag name	The logic editor and report display the tag name of an element.
Nr. of devices:	If multiple devices are connected in a safe series connection, you can enter the number of devices here.
Safety element	Specifies whether you can use the element for a safety function.

Parameter	Description
Output testing A short-circuit to High can be detected using test pulses.	<p>Without test pulses</p> <p>When this option is selected, the test pulses for this output are deactivated.</p> <p>Additional measures for all safety outputs of the module may be required, see "Safety-related parameters", page 130.</p> <p>This option is required for connected devices that cannot tolerate a brief interruption in the voltage supply (test pulses).</p>
	<p>Test pulses allowed</p> <p>When this option is selected, some test pulses are deactivated depending on other elements on the module. If at least one element on the safety outputs of the same module is configured with the Without test pulses option, not all test pulses are active.</p> <p>Test pulses are active for individual safety outputs. Additional measures may be required to achieve the safety-related characteristics, see "Safety-related parameters", page 130.</p> <p>This option is suitable when the test pulses have no effect on the connected device and they are not needed to achieve the required safety-related characteristics.</p>
	<p>With test pulses</p> <p>When this option is selected, the test pulses for this output are activated.</p> <p>This option is required for connected devices where regular test pulses are essential for achieving the required safety-related characteristics, see "Safety-related parameters", page 130</p>
Increased capacitive loads allowed	<p>This may be necessary for switching loads in cases where the voltage at the load does not drop to the Low level as quickly as expected.</p> <p>Examples</p> <ul style="list-style-type: none"> • Loads with a capacitance that is higher than the standard level permitted for the output, such as the supply voltage of PLC output cards that require safety-related switching. • Inductive loads that cause an overshoot in the positive voltage range once the induction voltage has decayed. <p>Take into account the longer response time.</p>

Further topics

- ["Discrepancy time", page 50](#)
- ["Maximum response time", page 135](#)
- ["Data sheet", page 130](#)
- ["Report main navigation menu", page 115](#)

7.5.6 Adding, configuring and expanding elements

7.5.6.1 Adding elements

Overview

The **Catalog** shows under **Elements** all of the devices (e.g., sensors, actuators, encoders) that can be connected to the inputs and outputs of the safety controller.

Approach

1. In the **Navigation pane**, click on **Hardware configuration**.
2. Drag an element from the **Catalog** into the workspace but do not release it.
 - ✓ All suitable and free inputs and outputs are highlighted.
3. Drag the element to the desired free input or output and release it.
 - ✓ The element is connected to the relevant input or output.

Complementary information

You can move elements from one module to another. This does not work for the following elements:

- Element with a connection to a **Fast shut off V1** function block
- Grouped elements, for example an operating mode selector switch or switch with locking device

7.5.6.2 Configuring elements

Prerequisites

- The input element or output element is connected to the safety controller in the workspace of the configuration software or is located in the parking area.

Approach

1. Double-click on the element.
- ✓ The configuration dialog opens.
2. Configure the element as required.
3. Click on **OK**.
- ✓ The changes are applied.

Further topics

- ["Configuration options for input elements", page 49](#)
- ["Expanding elements", page 55](#)

7.5.6.3 Expanding elements

Overview

Some elements are made up of a group of two or more sub-elements. For example, a guard locking element is made up of a safety switch as the input element and a lock as the output element.

You can expand these grouped elements, i.e., split them into their individual sub-elements.

Approach

1. Place the element in the parking area.
2. In the context menu of the element, select the **Expand** command.
- ✓ The element is expanded in the parking area.
3. Connect individual sub-elements to modules.

7.5.7 Creating customized elements

Overview

Customized elements allow you to create your own elements using preset configuration options (e.g., single-channel or dual-channel evaluation, discrepancy time, ON-OFF filtering, etc.).

A customized element is created from the template of an existing element.

Customized elements can also be exported and imported.

Important information



NOTE

Once an element is created, it is not possible to subsequently edit it.

- ▶ Check all settings before saving it.
 - ▶ If a correction is required, you can use the created element as a template for a new customized element.
-

Prerequisites

- The **Enable customized elements** option under **General settings** is selected.

Approach

1. In the **Navigation pane**, click on **Hardware configuration**.
2. In the **Catalog** under **Elements**, open the context menu for any element. Select an element that is similar to the element to be created.
3. In the context menu, select the **Save as customized element ...** command.
- ✓ The **Create personalized element template** window opens.
4. Under **Element**, specify a **Title** and a **Subtitle**: for each language.
5. Assign the element its own graphic, if applicable.
6. Under **Bill of materials information**, enter the required information about the element used.
7. Under **Editable element configuration**, edit the settings for the element.
8. Click on **OK** to save the new element and close the window.
- ✓ The new element is added to the **Catalog** under **Elements**.

Further topics

- ["Configuration options for input elements", page 49](#)

7.5.7.1 Exporting customized elements

Approach

1. In the context menu of the element to be exported, select the **Export ...** command.
2. Select the destination for the element to be exported or create a new folder and click on **OK**.
- ✓ The customized element is saved as an XML file.

7.5.7.2 Importing customized elements

Approach

1. In the context menu of any element in the **Catalog**, select the **Import ...** command.
2. Select the XML file with the element to be imported and click on **Open**.
- ✓ The customized element is imported.

7.6 Configuring the network interfaces

7.6.1 Configuring Modbus connections

Approach

1. In the main navigation pane, click **Configuration**.
2. In the navigation pane under **Main module**, select the **Fieldbus** menu item.
3. Activate the **Modbus server** option.
4. In the **Max. number of connections** field, select the number of connections.

7.6.2 Configuring SLMP connections

Approach

1. In the main navigation pane, click **Configuration**.
2. In the navigation pane under **Main module**, select the **Fieldbus** menu item.
3. Activate the **SLMP server** option.
4. In the **Port** field, select the port.

7.6.3 Configuring the output data (routing to CPU)

Overview

The CPUc2 main module can receive up to 50 bytes of output data from a higher-level control system. The actual data volume and contents depends on how the output data are configured in the higher-level control system.

The configuration of the output data includes the following points:

- Specifying the routing
- Optional: Enter the tag names for the data received from the network

Approach

1. In the main navigation pane, click **Configuration**.
2. In the navigation pane under **CPU main module > Fieldbus**, select the **Fieldbus** menu item.
3. Select a routing template and drag it onto a single byte or several bytes of the output data block.
- ✓ The bits, bytes or data formats are available as inputs in the logic editor.
- ✓ Each bit, byte or data format inherits a default tag name from the routing.
4. If required, edit the default tag name in the **Properties** tab.

Complementary information

Table 14: Colors of the bytes and bits of a record

Color	Meaning
Light blue	The byte or the bit is empty.
Blue	The byte or the bit is occupied. The relevant module, input or output is configured in the hardware configuration of the safety controller.
Gray	The byte or the bit is occupied. The relevant module, input or output is not yet configured in the hardware configuration of the safety controller.

You can monitor the status of the communication with the network. A status bit for the receipt of data from the network is provided for this. If the gateway detects a fault in the communication, it sets the contents of the output records and the associated status bit to Null.

7.6.4 Configuring the input data (routing to network)

Overview

The CPUc2 main module can send up to 50 bytes of input data to a higher-level control system.

The input data can comprise the statuses of the inputs and outputs, the logic results, or diagnostic data.

Approach

1. In the main navigation pane, click **Configuration**.
2. In the navigation pane under **CPU main module > Fieldbus**, select the **Fieldbus** menu item.
3. Select the required input data and drag it onto a single byte or several bytes of the input data block.

The following input data are available:

- **Routing Templates** contains templates for the routing of data from the logic editor.
 - **Inputs** contain the input values of the modules.
 - **Outputs** contain the output values of the modules as well as the logic results from the logic editor.
 - **Diagnostics** contains the checksums and status information of the modules.
- ✓ The bits, bytes or data formats are available as individual outputs in the logic editor.
 - ✓ Each bit, byte or data format inherits a default tag name from the routing.
 4. If required, edit the default tag name in the **Properties** tab.

Complementary information

Table 15: Colors of the bytes and bits of a record

Color	Meaning
Light blue	The byte or the bit is empty.
Blue	The byte or the bit is occupied. The relevant module, input or output is configured in the hardware configuration of the safety controller.
Gray	The byte or the bit is occupied. The relevant module, input or output is not yet configured in the hardware configuration of the safety controller.

The status of the communication with the network can be monitored. A status bit for the sending of data to the network is provided for this. If the gateway detects a fault in the communication, it sets the contents of the input records and the associated status bit to Null. The bit also switches to Null if the gateway is not ready for operation or the safety controller was stopped via the configuration software.

7.7 Logic editor main navigation

Logic editor main navigation

The function logic is programmed in a graphic **logic editor**.

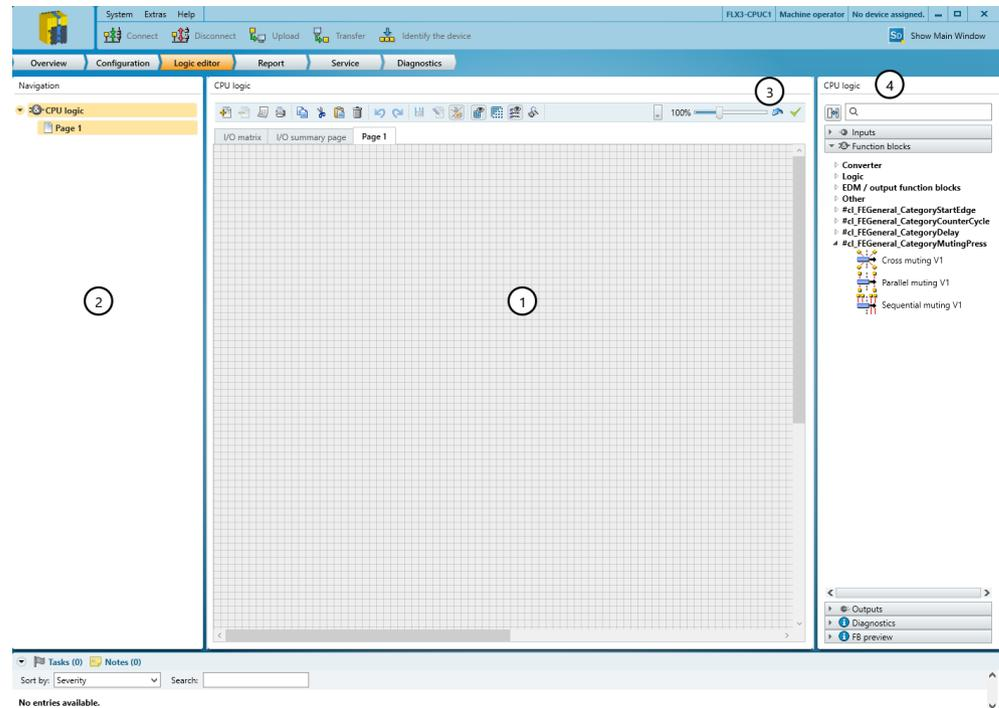

Figure 27: Logic editor

- ① Work sheet
- ② Navigation
- ③ Toolbar
- ④ CPU logic catalog

7.7.1 Inputs

Input elements

The **Inputs** selection window contains the following input elements for the logic program:

- Jump addresses
- The safety controller inputs that are in use
- Bits of the output record of a gateway
- Diagnostic elements
- CPU marker
- The **Static 0** and **Static 1** input elements
 - The output of the **Static 0** element is always set to 0.
 - The output of the **Static 1** element is always 1.
- The **First logic cycle** input element
 - This input element is set to 1 during the very first logic cycle that is performed after each transition from the Stop status to the Run status.
 - The input element is set to 0 throughout all other logic cycles.

When used appropriately, the **First logic cycle** input element initiates, for example, initialization functions in the logic program.

Further topics

- ["Jump addresses", page 111](#)
- ["Connecting elements", page 112](#)

7.7.2 Function blocks

Function blocks

The logic is programmed using function blocks. Function blocks contain inputs and outputs. The status of the outputs depends on the status of the inputs and the logic of the function block. Some function blocks can also be parameterized.

The logic programming results from the combination of various function blocks which are connected to one another and to the inputs and outputs of the safety controller.

Complementary information

- You can also activate additional inputs with certain function blocks.
- You can also activate additional status and diagnostic outputs with certain function blocks.
- Function blocks will be shown in red as long as all inputs have not been connected.
- Each function block has a function block index. The function block index shows the execution sequence.

Further topics

- ["Connecting elements", page 112](#)
- ["Configuring function blocks", page 112](#)

7.7.2.1 Logical function blocks

7.7.2.1.1 NOT V1

Overview

The value at the output is the inverted value of the input.

Principle of operation

Table 16: Inputs NOT V1

Input	Description
Input	Data type: Boolean

Table 17: Outputs NOT V1

Output	Description
Output	Data type: Boolean The value at the output is the inverted value of the input.

7.7.2.1.2 AND V1

Overview

If all evaluated inputs = 1, the output = 1.

Principle of operation

Table 18: Inputs AND V1

Input	Description
Input 1 Input 2	Data type: Boolean
Input 3 ... Input 8 (optional)	

Table 19: Outputs AND V1

Output	Description
Output	Data type: Boolean If all evaluated inputs = 1, the output = 1.

Table 20: Parameter AND V1

Parameter	Description
Number of inputs required	2 ... 8
invert	You can individually invert any visible input. At an inverted input, a 0 works internally in the same way as a 1 and vice versa.

7.7.2.1.3

OR V1

Overview

If at least one of the evaluated inputs = 1, the output = 1.

Principle of operation

Table 21: Inputs OR V1

Input	Description
Input 1 Input 2	Data type: Boolean
Input 3 ... Input 8 (optional)	

Table 22: Outputs OR V1

Output	Description
Output	Data type: Boolean If at least one of the evaluated inputs = 1, the output = 1.

Table 23: Parameter OR V1

Parameter	Description
Number of inputs required	2 ... 8
invert	You can individually invert any visible input. At an inverted input, a 0 works internally in the same way as a 1 and vice versa.

7.7.2.1.4

XOR V1 (exclusive OR)

Overview

If both inputs are complementary, then the output = 1.

Principle of operation

Table 24: Inputs XOR V1

Input	Description
Input 1 Input 2	Data type: Boolean

Table 25: Outputs XOR V1

Output	Description
Output	Data type: Boolean If both inputs are complementary, then the output = 1.

7.7.2.1.5 XNOR V1 (exclusive NOR)

Overview

If both inputs are equivalent, then the output = 1.

Principle of operation

Table 26: Inputs XNOR V1

Input	Description
Input 1 Input 2	Data type: Boolean

Table 27: Outputs XNOR V1

Output	Description
Output	Data type: Boolean If both inputs are equivalent, then the output = 1.

7.7.2.1.6 RS Flip-Flop V1

Overview

The function block saves the most recent value for the **Set** or **Reset** inputs and is used as a simple memory cell.

Principle of operation

Table 28: Inputs RS Flip-Flop V1

Input	Description
Set	Data type: Boolean
Reset	The Reset input has a higher priority than the Set input.

Table 29: Outputs RS Flip-Flop V1

Output	Description
Q	Data type: Boolean <ul style="list-style-type: none"> • If the Reset input = 1, then the output = 0. • If the Set input = 1 and the Reset input = 0, then the output = 1. • If the Set input = 0 and the Reset input = 0, then the output keeps the last value.
/Q	Data type: Boolean The value at the output is the inverted value of the Q output.

Table 30: Parameter RS Flip-Flop V1

Parameter	Description
Inverted	You can individually invert any visible input. At an inverted input, a 0 works internally in the same way as a 1 and vice versa.

Table 31: RS Flip-Flop V1 truth table without inversion

Input Set	Input Reset	Output Q
0	0	Keeps the last value
0	1	0
1	0	1
1	1	0

7.7.2.1.7 JK Flip-Flop V1

Overview

The J and K inputs only affect the outputs if an adjustable signal edge is detected at the Clock input.

Principle of operation

Table 32: Inputs JK Flip-Flop V1

Input	Description
J	Data type: Boolean
K	
Clock	Data type: Boolean Depending on the Inverted parameter, a rising or falling signal edge together with the statuses of the J and K inputs affects the outputs.

Table 33: Outputs JK Flip-Flop V1

Output	Description
Q	Data type: Boolean <ul style="list-style-type: none"> If the J input = 1 and the K input = 0, then the Q output = 1. If the J input = 0 and the K input = 1, then the Q output = 0. If the J and K inputs = 0, the Q output keeps the last value. If the J and K inputs = 1, the Q output inverts the last value.
/Q	Data type: Boolean The value at the output is the inverted value of the Q output.

Table 34: Parameter JK Flip-Flop V1

Parameter	Description
Inverted	<ul style="list-style-type: none"> Input J and K: You can individually invert any visible input. At an inverted input, a 0 works internally in the same way as a 1 and vice versa. Input Clock: No inversion: The function block reacts to rising signal edges. With inversion: The function block reacts to falling signal edges.

Table 35: JK Flip-Flop V1 truth table without input inversion

Input J	Input K	Input Clock	Output Q
0	0	↑	Keeps the last value
0	1	↑	0
1	0	↑	1
1	1	↑	Inverts the last value
X	X	No rising signal edge	Keeps the last value

X: Value can be 0 or 1.
 ↑: Rising signal edge
 ↓: Falling signal edge

7.7.2.2 Function blocks for data conversion

7.7.2.2.1 UInt8 to One-hot V1

Overview

Depending on the parameter set, the function block converts a decimal value at the input into a 1-of-N or Equal-and-Lower code.

An individual function block converts 8 decimal values depending on the set value range. You can convert larger value areas by using several function blocks and configuring them accordingly.

Principle of operation

Table 36: Inputs UInt8 to One-hot V1

Input	Description
Input	Data type: UInt8

Table 37: Outputs UInt8 to One-hot V1

Output	Description
Output value 0 ... Output value 7	Data type: Boolean Depends on the Conversion mode parameter and the value at the input.

Table 38: Parameter UInt8 to One-hot V1

Parameter	Description
Conversion mode	<ul style="list-style-type: none"> 1-of-N Exactly 1 output = 1. Example: Decimal value 5: Output 5 = 1, all other outputs = 0. Equal-and-Lower Outputs are 1 if they correspond to the decimal value or are lower than the decimal value. Example: Decimal value 5: Output 0 ... 5 = 1, all other outputs = 0.
Range offset	<p>0 ... 31</p> <p>A function block covers 8 decimal values. You must use several function blocks in order to be able to convert more than 8 decimal values. With the Range offset parameter, you determine which value range the function block converts.</p> <p>You can use the following formula to calculate which decimal value corresponds to a function block output:</p> <p>Decimal value = N + 8 × R</p> <ul style="list-style-type: none"> N = Number of the output R = Area offset <p>Example of output 0 with Range offset = 0:</p> <ul style="list-style-type: none"> Output 0 + 8 × 0 => output 0 = value 0 <p>Example of output 7 with Range offset = 31:</p> <ul style="list-style-type: none"> Output 7 + 8 × 31 => output 7 = value 255

7.7.2.2.2

One-hot to UInt8 V1

Overview

The function block converts binary inputs into decimal values.

Principle of operation

Table 39: Inputs One-hot to UInt8 V1

Input	Description
Value 0 ... Value 7 (optional)	Data type: Boolean

Table 40: Outputs One-hot to UInt8 V1

Output	Description
Result	Data type: UInt8 Depending on the Conversion mode parameter.

Output	Description
Status	<p>Data type: Boolean</p> <ul style="list-style-type: none"> If an invalid combination is present at the inputs, the Status output changes to 0 (error). If a correct input combination is present, the function block resets the error. The Status output changes back to 1 in this case.

Table 41: Parameter One-hot to UInt8 V1

Parameter	Description
Conversion mode	<ul style="list-style-type: none"> One-hot Exactly one input = 1. If several inputs = 1 or no input = 1, then the function block evaluates this as an error. Highest dominant At least one input = 1. The input with the highest value determines the decimal value at the output. If no input = 1, then the function block evaluates this as an error. Lowest dominant At least one input = 1. The input with the lowest value determines the decimal value at the output. If no input = 1, then the function block evaluates this as an error.
Range offset	<p>0 ... 31</p> <p>A function block covers 8 decimal values.</p> <p>With the Range offset parameter, you determine which value range the function block converts.</p> <p>The decimal value at the Result output depends on the area offset and the number of the input and is calculated using this formula:</p> <p>Decimal value at the Result output = $N + 8 \times R$</p> <ul style="list-style-type: none"> N = Number of the input R = Area offset <p>Example for Range offset = 0:</p> <ul style="list-style-type: none"> Input 0 + 8 × 0 => decimal value at the Result output = 0 Input 7 + 8 × 0 => decimal value at the Result output = 7 <p>Example for Range offset = 31:</p> <ul style="list-style-type: none"> Input 0 + 8 × 31 => decimal value at the Result output = 248 Input 7 + 8 × 31 => decimal value at the Result output = 255

7.7.2.2.3

UInt8 to Bool V1

Overview

The function block converts a sign-free 8-bit integer value (UINT8) at the input into 8 Boolean values at **Output 1 ... Output 8**.

Principle of operation

Table 42: Inputs UInt8 to Bool V1

Input	Description
Input 1	Data type: UINT8

Table 43: Outputs UInt8 to Bool V1

Output	Description
Output 1 ... Output 8	Data type: Boolean

Table 44: Truth table UInt8 to Bool V1

Input 1	Output 8	Output 7	Output 6	Output 5	Output 4	Output 3	Output 2	Output 1
0	0	0	0	0	0	0	0	0
1	0	0	0	0	0	0	0	1
2	0	0	0	0	0	0	1	0
3	0	0	0	0	0	0	1	1
4	0	0	0	0	0	1	0	0
...
253	1	1	1	1	1	1	0	1
254	1	1	1	1	1	1	1	0
255	1	1	1	1	1	1	1	1

7.7.2.2.4 Bool to UInt8 V1

Overview

The function block converts up to 8 Boolean input values into a sign-free 8-bit integer value (UINT8).

Principle of operation

Table 45: Inputs Bool to UInt8 V1

Input	Description
Input 1	Data type: Boolean
Input 2 ... Input 8 (optional)	

Table 46: Outputs Bool to UInt8 V1

Output	Description
Output 1	Data type: UINT8

Table 47: Truth table Bool to UInt8 V1

Input 8	Input 7	Input 6	Input 5	Input 4	Input 3	Input 2	Input 1	Output 1
0	0	0	0	0	0	0	0	0
0	0	0	0	0	0	0	1	1
0	0	0	0	0	0	1	0	2
0	0	0	0	0	0	1	1	3
0	0	0	0	0	1	0	0	4
...
1	1	1	1	1	1	0	1	253
1	1	1	1	1	1	1	0	254
1	1	1	1	1	1	1	1	255

7.7.2.3 Function blocks for time functions

7.7.2.3.1 Fixed on-delay timer V1

Overview

The function block delays switch-on of the **Enabled** output by a configurable period of time if a rising signal edge is present. The output is switched off without delay time if a falling signal edge is present.

Principle of operation

Table 48: Inputs Fixed on-delay timer V1

Input	Description
Control	Data type: Boolean

Table 49: Outputs Fixed on-delay timer V1

Output	Description
Enabled	Data type: Boolean Depending on the Switch-on delay time parameter.

Table 50: Parameter Fixed on-delay timer V1

Parameter	Description
Switch-on delay time	0 ... 300 s in 1-ms steps ¹⁾ <ul style="list-style-type: none"> The delay time begins with a rising signal edge at the Control input. If, after expiration of the configured delay time, the Control input is still 1, the Enabled output = 1. If the Control input returns to 0 before expiration of the configured switch-on delay time, the Enabled output remains = 0. The timer for the switch-on delay time is reset to 0.

¹⁾ 0 = No delay

Complementary information

If the configured delay time is less than or not a multiple of the logic execution time, then the delay time extends to the next logic cycle.

If, during the first logic cycle, the **Control** input = 1 and a switch-on delay time > 0 is configured, then the **Enabled** output = 0. If the **Control** input remains at 1, then the **Enabled** output remains 0 until the configured switch-on delay time has expired (Prerequisite: First logic cycle < configured switch-on delay time).

7.7.2.3.2

Fixed off-delay timer V1

Overview

The function block delays switch-off of the **Enabled** output by a configurable period of time if a falling signal edge is present. The output is switched on without delay time if a rising signal edge is present.

Principle of operation

Table 51: Inputs Fixed off-delay timer V1

Input	Description
Control	Data type: Boolean

Table 52: Outputs Fixed off-delay timer V1

Output	Description
Enabled	Data type: Boolean Depending on the Switch-off delay time parameter.

Table 53: Parameter Fixed off-delay timer V1

Parameter	Description
Switch-off delay time	0 ... 300 s in 1-ms steps ¹⁾ <ul style="list-style-type: none"> The switch-off delay time begins with a falling signal edge at the Control input. If, after expiration of the configured switch-off delay time, the Control input is still 0, the Enabled output = 0. If the Control input returns to 1 before expiration of the configured switch-on delay time, the Enabled output remains = 1. The timer for the switch-off delay time is reset to 0.

1) 0 = No delay

Sequence/timing diagram

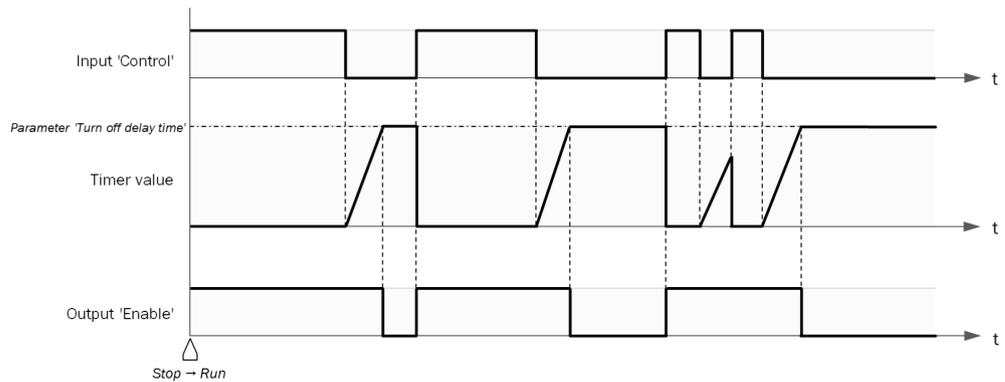

Figure 28: Sequence/timing diagram Fixed off-delay timer V1

Complementary information

If the configured delay time is less than or not a multiple of the logic execution time, then the delay time extends to the next logic cycle.

If, during the first logic cycle, the **Control** input = 0, the **Enabled** output = 0. The **Enabled** output remains 0 until the **Control** input = 1.

If, during the first logic cycle, the **Control** input = 1, the **Enabled** output = 1. The **Enabled** output remains 1 until the **Control** input = 0 and the configured switch-off delay time then expires.

7.7.2.3.3

Adjustable on-delay timer V1

Overview

This function block outputs a rising signal edge (0–1) at the **Control** input at the **Enabled** output after a delay.

You can configure up to four delay times. The delay times are activated via the associated inputs. The total delay time at the **Enabled** output is equal to the sum of all the activated delay times.

Principle of operation

Table 54: Inputs Adjustable on-delay timer V1

Input	Description
Control	Data type: Boolean
Delay 1 ... Delay 4 (optional)	Data type: Boolean

Table 55: Outputs Adjustable on-delay timer V1

Output	Description
Enabled	Data type: Boolean If the Control input returns to 0 before the selected total delay time expires, the Enabled output remains = 0
Time changed	Data type: Boolean If the resultant delay time is changed while the Control input is being output after a delay (i.e., the timer is still running at the moment the time is changed), then the Time changed output = 1. The previously set delay time continues to apply. The new delay time only becomes active at the next delay cycle.

Table 56: Parameter Adjustable on-delay timer V1

Parameter	Description
Delay 1 ... Delay 4	0 ... 600 s in 1 ms increments An input is only available if you configure a delay time > 0 for the corresponding parameter.

Sequence/timing diagram

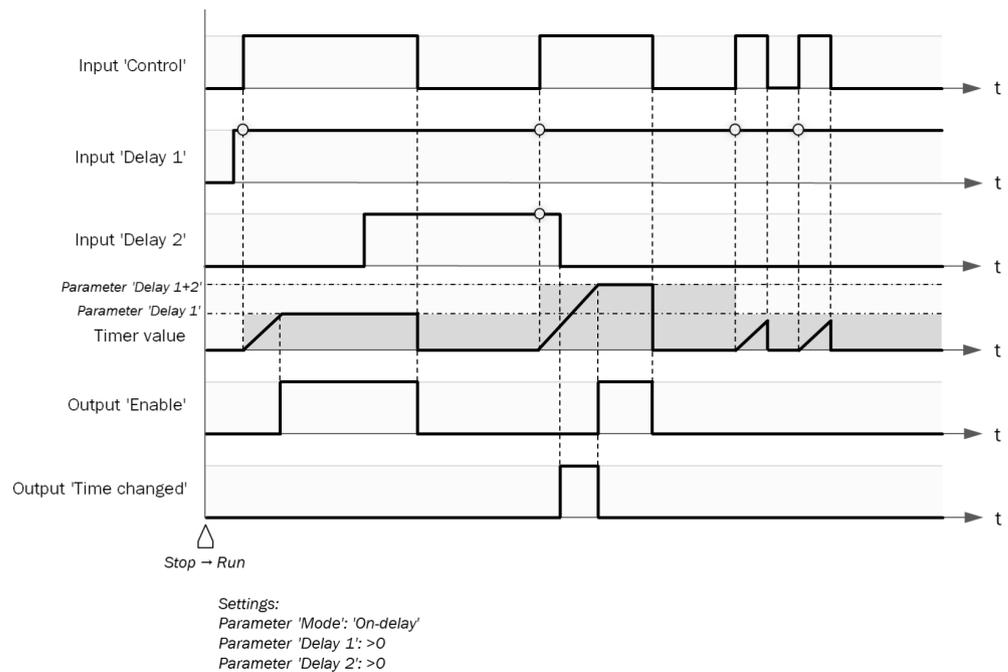

Figure 29: Sequence/timing diagram Adjustable on-delay timer V1

Complementary information

If the delay time selected using the **Delay 1 ... Delay 4** inputs is not a multiple of the logic execution time, the delay time is extended to the next logic cycle.

If, during the first logic cycle, the **Control** input = 0, the **Enabled** output = 0.

If, during the first logic cycle, the **Control** input = 1 and no delay time is configured, the **Enabled** output = 1.

If, during the first logic cycle, the **Control** input = 1 and a delay time > 0 is configured, the function block sets the **Enabled** output to 1 after the total delay time has elapsed.

7.7.2.3.4 Adjustable off-delay timer V1

Overview

This function block outputs a falling signal edge (1-0) at the **Control** input at the **Enabled** output after a delay.

You can configure up to four delay times. The delay times are activated via the associated inputs. The total delay time at the **Enabled** output is equal to the sum of all the activated delay times.

Principle of operation

Table 57: Inputs Adjustable off-delay timer V1

Input	Description
Control	Data type: Boolean
Delay 1 ... Delay 4 (optional)	Data type: Boolean

Table 58: Outputs Adjustable off-delay timer V1

Output	Description
Enabled	Data type: Boolean If the Control input returns to 1 before the selected total delay time expires, the Enabled output remains = 1
Time changed	Data type: Boolean If the resultant delay time is changed while the Control input is being output after a delay (i.e., the timer is still running at the moment the time is changed), then the Time changed output = 1. The previously set delay time continues to apply. The new delay time only becomes active at the next delay cycle.

Table 59: Parameter Adjustable off-delay timer V1

Parameter	Description
Delay 1 ... Delay 4	0 ... 600 s in 1 ms increments An input is only available if you configure a delay time > 0 for the corresponding parameter.

Sequence/timing diagram

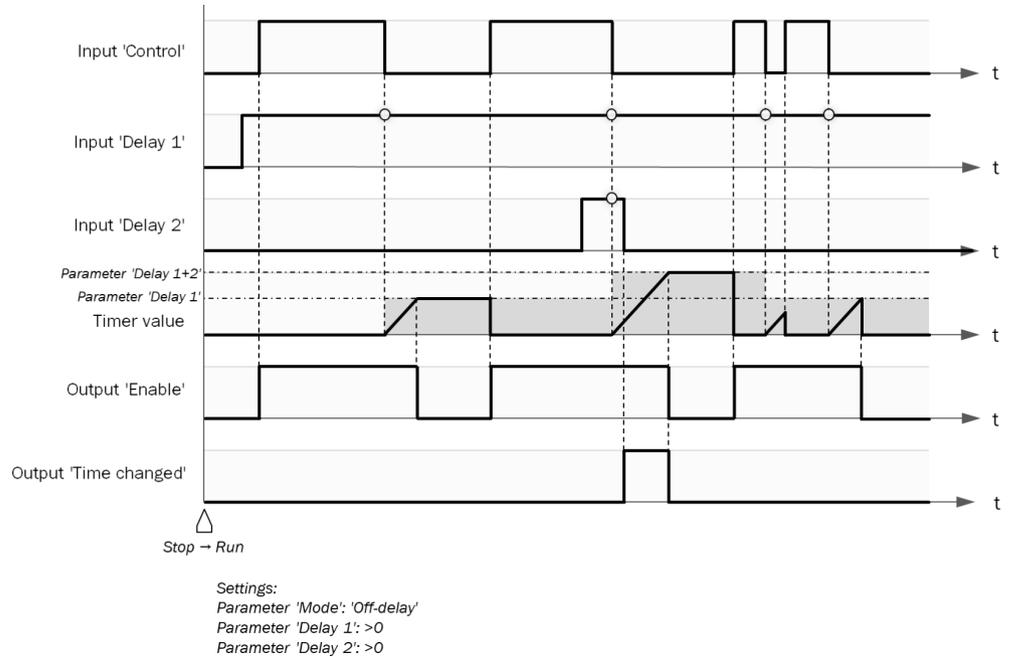

Figure 30: Sequence/timing diagram Adjustable off-delay timer V1

Complementary information

If the delay time selected using the **Delay 1 ... Delay 4** inputs is not a multiple of the logic execution time, the delay time is extended to the next logic cycle.

If, during the first logic cycle, the **Control** input = 0, the **Enabled** output = 0.

If, during the first logic cycle, the **Control** input = 1 and no delay time is configured, the **Enabled** output = 1.

If, during the first logic cycle, the **Control** input = 1 and a delay time > 0 is configured, the function block sets the **Enabled** output to 1 after the total delay time has elapsed.

7.7.2.3.5

Clock generator V1

Overview

The function block generates a pulsed signal. The elementary period and pulse duration are configurable.

Principle of operation

Table 60: Inputs Clock generator V1

Input	Description
Enable	Data type: Boolean

Table 61: Outputs Clock generator V1

Output	Description
Clock	Data type: Boolean <ul style="list-style-type: none"> If the Enable input = 1, then the Clock output pulsates. If the Enable input = 0, then the Clock output becomes = 0.

Table 62: Parameter Clock generator V1

Parameter	Description
Rounding mode	The input values of the Clock period and Pulse time parameters are rounded in such a way that a separation of at least one logic execution time to one another and to 0 is maintained. This parameters specifies whether to round up or round down. The parameter setting is ignored if the rounding violates the permissible limit values.
Stop mode	Determines the end of the pulsed signal. <ul style="list-style-type: none"> • Immediate If the Enable input changes from 1 to 0, then the Clock output immediately changes to 0. • After last clock pulse If the Enable input changes from 0 to 1, the function block will complete the current elementary period.
Function block deactivated	Clock period and Pulse time = 0. Clock output = Enable input
Clock period	An elementary period begins with the pulse duration. This is followed by a pause, the Clock output = 0 . The next elementary period then begins. see figure 31 The duration of the elementary period should be longer than the sum of the pulse duration and logic execution time. The parameter has an input value and an effective value. The configuration software corrects the input value to the correct effective value based on the Rounding mode and Pulse time parameters.
Pulse time	The pulse duration must be shorter than the elementary period. see figure 31 The pulse duration can be shorter than the logic execution time. The parameter has an input value and an effective value. The configuration software corrects the input value to the correct effective value based on the Rounding mode and Clock period parameters.

Sequence/timing diagram

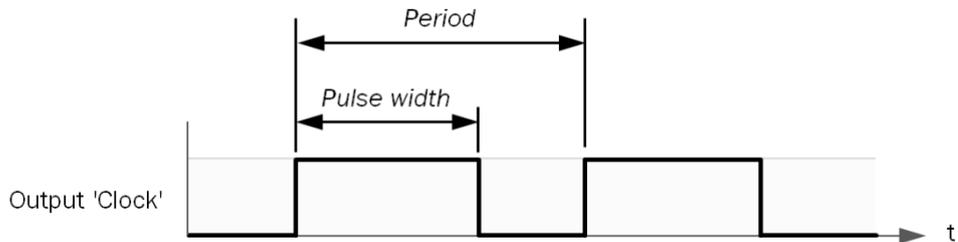

Figure 31: Parameter diagram

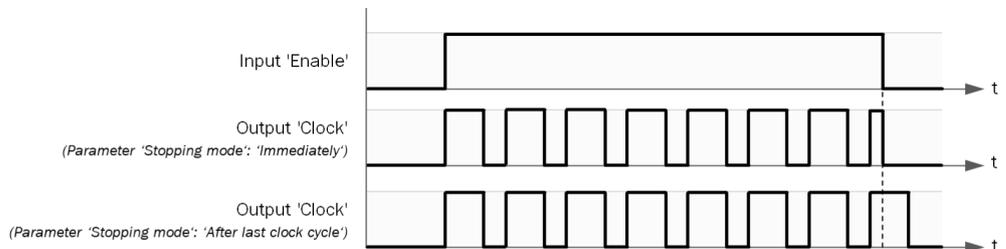

Figure 32: Sequence/timing diagram Clock generator V1

7.7.2.3.6 Event counter (up) V1

Overview

The function block counts the number of rising signal edges at the **Up** input.

Principle of operation

Table 63: Inputs Event counter (up) V1

Input	Description
Up	Data type: Boolean A rising signal edge (0–1) at the Up input increases the value of the internal counter by “1” as long as the maximum value has not been reached. ¹⁾ If the maximum value is exceeded, the behavior depends on the Behavior with overflow parameter.
Reset to zero	Data type: Boolean A rising signal edge (0–1) at the input sets the value of the internal counter to 0.

¹⁾ If, during the first logic cycle, the input is already 1, then function block does not evaluate this as a rising signal edge.

Table 64: Outputs Event counter (up) V1

Output	Description
Counter value	Data type: UINT16 Outputs the value of the internal counter (0 ... 65,535).
Upper limit	Data type: Boolean Is 1 as long as the counter = Maximum value
Overflow	Data type: Boolean See the Behavior with overflow parameters

Table 65: Parameter Event counter (up) V1

Parameter	Description
Initialization value	The start value of the internal counter is set to 0 in the first logic cycle.
Behavior with overflow	This parameter controls the behavior of the function block when the internal counter has reached the maximum value and then another counting pulse occurs at the Up input. <ul style="list-style-type: none"> • No overflow function All other rising signal edges at the Up input are ignored. • Overflow function <ul style="list-style-type: none"> ◦ The Overflow output is 1 for the duration of a logic cycle. ◦ The value of the internal counter is set to 0.
Maximum value	1 ... 65,535

Further topics

- ["Single-channel use of safety inputs", page 30](#)

7.7.2.3.7 Event counter (down) V1

Overview

The function block counts the number of rising signal edges at the **Down** input.

Principle of operation

Table 66: Inputs Event counter (down) V1

Input	Description
Down	Data type: Boolean A rising signal edge (0-1) at the Down input decreases the value of the internal counter by "1" as long as 0 has not been reached. ¹⁾ If the value falls below 0, the behavior depends on the Behavior with underflow parameter.
Set to reload value	Data type: Boolean A rising signal edge (0-1) at the input sets the value of the internal counter to the configured value of the Reload value parameter.

¹⁾ If, during the first logic cycle, the input is already 1, then function block does not evaluate this as a rising signal edge.

Table 67: Outputs Event counter (down) V1

Output	Description
Counter value	Data type: UINT16 Outputs the value of the internal counter (0 ... 65,535).
Lower limit	Data type: Boolean Is 1 as long as the counter = 0
Underflow	Data type: Boolean See the Behavior with underflow parameters

Table 68: Parameter Event counter (down) V1

Parameter	Description
Initialization value	The start value of the internal counter is set to the value of the Maximum value parameter in the first logic cycle.
Behavior with underflow	This parameter controls the behavior of the function block when the internal counter has reached the value 0 and then another counting pulse occurs at the Down input. <ul style="list-style-type: none"> • No underflow function All other rising signal edges at the Down input are ignored. • Underflow function <ul style="list-style-type: none"> ◦ The Underflow output is 1 for the duration of a logic cycle. ◦ The value of the internal counter is set to the Maximum value parameter.
Maximum value	1 ... 65,535
Reload value	Corresponds to the Maximum value parameter.

Further topics

- ["Single-channel use of safety inputs", page 30](#)

7.7.2.3.8

Event counter (up and down) V1

Overview

The function block counts the number of rising signal edges at the **Up** and **Down** inputs.

Principle of operation

Table 69: Inputs Event counter (up and down) V1

Input	Description
Up	Data type: Boolean A rising signal edge (0-1) at the Up input increases the value of the internal counter by "1" as long as the maximum value has not been reached. ¹⁾ If the maximum value is exceeded, the behavior depends on the Behavior with overflow parameter. The input is ignored when a rising signal edge occurs simultaneously at the Reset to zero , Set to reload value or Down input.
Down	Data type: Boolean A rising signal edge (0-1) at the Down input decreases the value of the internal counter by "1" as long as 0 has not been reached. ¹⁾ If the value falls below 0, the behavior depends on the Behavior with underflow parameter. The input is ignored when a rising signal edge occurs simultaneously at the Reset to zero , Set to reload value or Up input.
Reset to zero	Data type: Boolean A rising signal edge (0-1) at the input sets the value of the internal counter to 0.
Set to reload value	Data type: Boolean A rising signal edge (0-1) at the input sets the value of the internal counter to the configured value of the Reload value parameter. The input is ignored when a rising signal edge (0-1) occurs simultaneously at the Reset to zero input.

¹⁾ If, during the first logic cycle, the input is already 1, then function block does not evaluate this as a rising signal edge.

Table 70: Outputs Event counter (up and down) V1

Output	Description
Counter value	Data type: UINT16 Outputs the value of the internal counter (0 ... 65,535).
Upper limit	Data type: Boolean Is 1 as long as the counter = Maximum value
Lower limit	Data type: Boolean Is 1 as long as the counter = 0
Overflow	Data type: Boolean See the Behavior with overflow parameters
Underflow	Data type: Boolean See the Behavior with underflow parameters

Table 71: Parameter Event counter (up and down) V1

Parameter	Description
Initialization value	The parameter defines to which start value the internal counter is set after the first logic cycle. <ul style="list-style-type: none"> Set to 0 at the start time The Lower limit output is immediately set to 1. Set start to reload value at the start time If Reload value = Maximum value, then the Upper limit output is immediately set to 1. If Reload value = 0, then the Lower limit output is immediately set to 1. Set to maximum value at the start time The Upper limit output is immediately set to 1.

Parameter	Description
Behavior with overflow	<p>This parameter controls the behavior of the function block when the internal counter has reached the maximum value and then another counting pulse occurs at the Up input.</p> <ul style="list-style-type: none"> • No overflow function All other rising signal edges at the Up input are ignored. • Overflow function <ul style="list-style-type: none"> ◦ The Overflow output is 1 for the duration of a logic cycle. ◦ The value of the internal counter is set to 0.
Behavior with under-flow	<p>This parameter controls the behavior of the function block when the internal counter has reached the value 0 and then another counting pulse occurs at the Down input.</p> <ul style="list-style-type: none"> • No underflow function All other rising signal edges at the Down input are ignored. • Underflow function <ul style="list-style-type: none"> ◦ The Underflow output is 1 for the duration of a logic cycle. ◦ The value of the internal counter is set to the Maximum value parameter.
Maximum value	<p>1 ... 65,535 The value must be greater than or equal to Reload value.</p>
Reload value	<p>0 ... 65,535 The value must be less than or equal to the Maximum value parameter.</p>

Further topics

- ["Single-channel use of safety inputs", page 30](#)

7.7.2.4 Function blocks for input evaluation

7.7.2.4.1 Two hand control (2 inputs) V1

Overview

This function block provides the logic for monitoring the inputs of a two-hand control device. The category 1 (Type IIIA) or category 4 (Type IIIC) according to EN 574 depends on the wiring and parameterization.

Principle of operation

Table 72: Inputs Two hand control (2 inputs) V1

Input	Description
1A (NO) 1B (NC)	Data type: Boolean

Table 73: Outputs Two hand control (2 inputs) V1

Output	Description
Enabled	<p>Data type: Boolean</p> <ul style="list-style-type: none"> • 0 = not enabled • 1 = enabled <p>The Enabled output is set to 1 if the following conditions are met:</p> <ul style="list-style-type: none"> ◦ Both inputs are inactive at the same time for at least the duration of the logic execution time ◦ Both inputs are then active

Output	Description
Synchronization status	Data type: Boolean <ul style="list-style-type: none"> 0 = Error Synchronization time exceeded. 1 = No error or unknown

Synchronization time

The synchronization time is the amount of time for which the two inputs are allowed to have different values.

Fixed value: 500 ms in accordance with EN 574

Sequence monitoring

The **Enabled** output is set to 1 if both inputs were deactivated at the same time for at least the logic execution time before being activated.

If the **Enabled** output = 1 and then at least one input becomes deactivated, then the **Enabled** output = 0.

Complementary information

Different propagation times of the input signals can lead to a lengthening or shortening of the synchronization time.

Further topics

- ["Configuration options for input elements", page 49](#)

7.7.2.4.2

Two hand control (4 inputs) V1

Overview

This function block provides the logic for monitoring the inputs of a two-hand control device. The category 1 (Type IIIA) or category 4 (Type IIIC) according to EN 574 depends on the wiring and parameterization.

Principle of operation

Table 74: Inputs Two hand control (4 inputs) V1

Input	Description
1A (NO) 1B (NC) 2A (NO) 2B (NC)	Data type: Boolean <ul style="list-style-type: none"> Input pair 1: 1A (NO), 1B (NC) Input pair 2: 2A (NO), 2B (NC)

Table 75: Outputs Two hand control (4 inputs) V1

Output	Description
Enabled	Data type: Boolean <ul style="list-style-type: none"> 0 = not enabled 1 = enabled The Enabled output is set to 1 if the following conditions are met: <ul style="list-style-type: none"> o Both input pairs are inactive at the same time for at least the duration of the logic execution time o Both input pairs are then active

Output	Description
Status of input pair 1	Data type: Boolean
Status of input pair 2	<ul style="list-style-type: none"> • 0 = Error Input pair has not gone into a complementary status within the discrepancy time. • 1 = No error or unknown
Synchronization status	Data type: Boolean <ul style="list-style-type: none"> • 0 = Error Synchronization time exceeded. • 1 = No error or unknown

Table 76: Parameter Two hand control (4 inputs) V1

Parameter	Description
Discrepancy time (pair 1)	The discrepancy time defines how long the two inputs can continue to have discrepant values after a change in either of the input signals without this being regarded as an error. 0 ... 30 s If set to 0, discrepancy monitoring is deactivated. The effective value is the input value rounded up to the next multiple of the logic execution time. The effective discrepancy time must be = 0 or \geq the logic execution time.
Discrepancy time (pair 2)	

Synchronization time

The synchronization time is the amount of time for which the input pairs 1 and 2 are allowed to have different values.

Fixed value: 500 ms in accordance with EN 574

The synchronization time evaluates the relationship between the two dual-channel evaluation functions. By contrast, the discrepancy time relates to one pair of inputs for one dual-channel evaluation function.

Sequence monitoring

The **Enabled** output is set to 1 if both input pairs were deactivated at the same time for at least the logic execution time before being activated.

If the **Enabled** output = 1 and then at least one input of an input pair becomes deactivated, then the **Enabled** output = 0.

Sequence/timing diagram

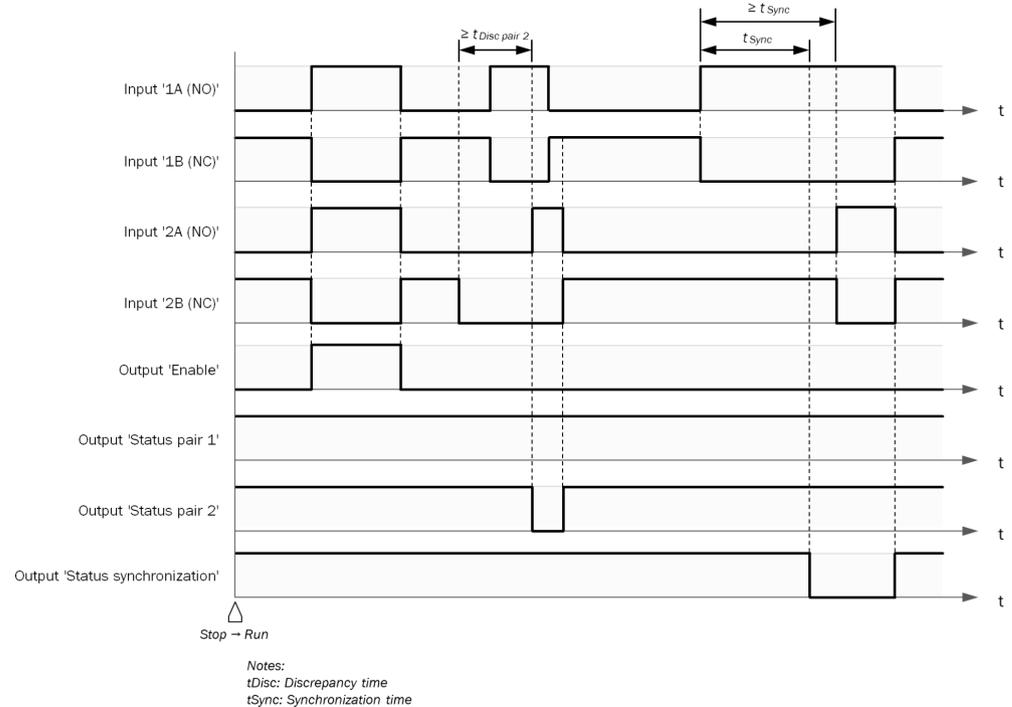

Figure 33: Sequence/timing diagram Two hand control (4 inputs) V1

Complementary information

- Different propagation times of the input signals can lead to a lengthening or shortening of the discrepancy time and/or synchronization time.
- Possible statuses of an input pair

Table 77: Possible statuses of an input pair

Input A (normally open)	Input B (normally closed)	Status
0	0	Discrepant
0	1	Deactivated
1	0	Active
1	1	Discrepant

Further topics

- ["Configuration options for input elements", page 49](#)

7.7.2.4.3

Dual channel monitor V1

Overview

This function block evaluates dual-channel switches or sensors. The function block checks the sequence and discrepancy of two inputs.

You can use the function block if, for example, you are unable to configure dual-channel evaluation in the hardware configuration.

Principle of operation

Table 78: Inputs Dual channel monitor V1

Input	Description
Input A	Data type: Boolean
Input B	

Table 79: Outputs Dual channel monitor V1

Output	Description
Enabled	Data type: Boolean The dual-channel evaluation can only switch to active (Enabled output changes from 0 to 1) after a correct sequence. The inputs are not allowed to change from active to discrepant and then back to active. The Enabled output can only change back to 1 if both inputs are deactivated at the same time for at least the logic execution time.
Status	Data type: Boolean <ul style="list-style-type: none"> • 0 = Error Discrepancy error or sequence error • 1 = No error

Table 80: Parameter Dual channel monitor V1

Parameter	Description
Input mode	<ul style="list-style-type: none"> • Equivalent • Complementary
%Ignore%	This parameter determines the behavior of the function block during the first logic cycle. <ul style="list-style-type: none"> • Active For the first logic cycle, the status must be “Deactivated” (e.g. input mode = Equivalent: Input A = 0 and Input B = 0). If the status in the first logic cycle is not “Deactivated”, the Enabled output remains 0 until the status is “Deactivated” for at least one logic cycle, then is “Active”. • Not active If the status in the first logic cycle is “Discrepant”, the Enabled output = 1 as soon as the status changes to “Active” during the discrepancy time. If the status is “Active” in the first logic cycle, the Enabled output = 1 without delay time.
Deactivating discrepancy monitoring	<ul style="list-style-type: none"> • Active (discrepancy time monitoring deactivated) An infinitely long discrepancy time is allowed. • Inactive (discrepancy time monitoring activated) You can configure a maximum allowed Discrepancy time.
Discrepancy time	0 ... 30 s The discrepancy time defines how long the two inputs can continue to have discrepant values after a change in either of the input signals without this being regarded as an error. If signals from tested sensors are connected, the discrepancy time must exceed the test pulse width + the maximum OFF-ON delay of the test output that is being used. You can find these values, for example, in the report. When set to 0, both inputs must switch during the same logic cycle.

Table 81: Truth table Dual channel monitor V1

Input mode	Input A	Input B	Status	Output Enabled
Equivalent	0	0	Deactivated	0
	0	1	Discrepant, input A switched off	0
	1	0	Discrepant, input B switched off	0
	1	1	Active, if the correct sequence has been observed and the configured discrepancy time has not been exceeded	1

Input mode	Input A	Input B	Status	Output Enabled
Complementary	0	1	Deactivated	0
	0	0	Discrepant, input A switched off	0
	1	1	Discrepant, input B switched off	0
	1	0	Active, if the correct sequence has been observed and the configured discrepancy time has not been exceeded	1

Sequence/timing diagram

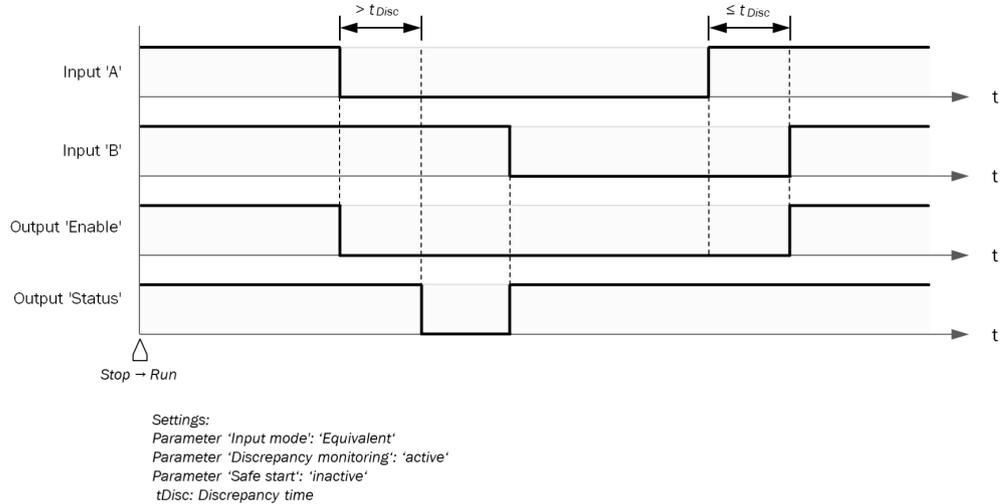

Figure 34: Sequence/timing diagram Dual channel monitor V1

Complementary information

Different propagation times of the input signals can lead to a lengthening or shortening of the discrepancy time.

Further topics

- ["Configuration options for input elements", page 49](#)

7.7.2.4.4

Edge detection V1

Overview

This function block detects rising and/or falling signal edges at the input depending on the set parameter.

Principle of operation

Table 82: Inputs Edge detection V1

Input	Description
Input	Data type: Boolean

Table 83: Outputs Edge detection V1

Output	Description
Edge detected	Data type: Boolean When the function block detects the relevant type of signal edge, the function block sets the Edge detected output to 1 for a logic cycle.

Table 84: Parameter Edge detection V1

Parameter	Description
Edge detection	<ul style="list-style-type: none"> • Positive (rising signal edges) • Negative (falling signal edges) • Positive and negative (rising and falling signal edges)

Sequence/timing diagram

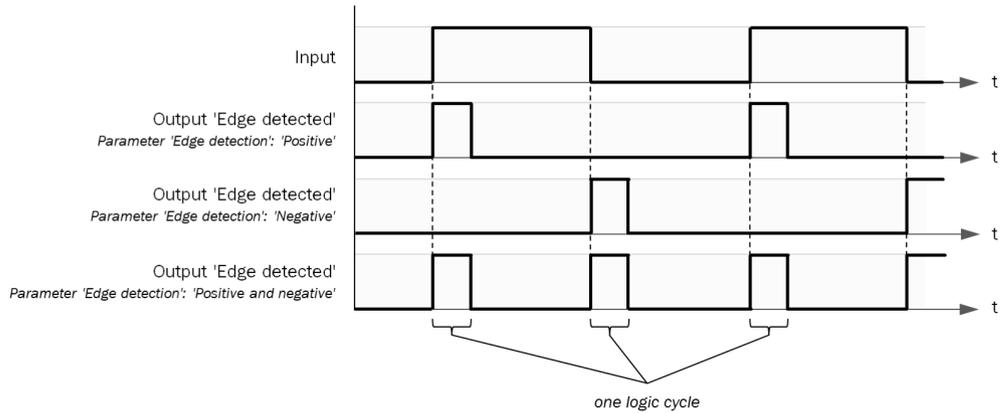

Figure 35: Sequence/timing diagram Edge detection V1

Complementary information

- If the input is already 1 during the first logic cycle, the function block does not evaluate this as a positive edge.
- If the input is already 0 during the first logic cycle, the function block does not evaluate this as a negative edge.

7.7.2.5 Function blocks for output control

7.7.2.5.1 External device monitoring V1

Overview

The function block monitors a switching amplifier with a feedback channel (e.g., a contactor with positively guided contacts) connected to the **Enabled** output. The function block checks whether the feedback signal connected to the **EDM feedback signal** input switches as expected.

Important information



NOTE

If an ON-OFF filter or a discrepancy time, for example, is configured for the input signals in the hardware configuration, then the statuses of the **Control input** input and the **EDM feedback signal** input may differ over time. This can result in an error.

- ▶ Avoid time differences in the signals.
- ▶ Configure the **Max. feedback delay** parameter.

Principle of operation

Table 85: Inputs External device monitoring V1

Input	Description
Control input	Data type: Boolean The input must be connected to the logic signal that represents the desired status for the external device. If the input in the first logic cycle = 1, then this is evaluated as a rising edge.
EDM feedback signal	Data type: Boolean The input is connected to the feedback signal of the external switching amplifier. The general expectation is that the EDM feedback signal will assume the inverted value of the Control input input within the maximum feedback delay time that has been configured.

Table 86: Outputs External device monitoring V1

Output	Description
Enabled	Data type: Boolean The output controls the external switching amplifier. <ul style="list-style-type: none"> • If the Control input input = 0 or the Status output = 0, then the Enabled output = 0. • If the Control input input = 1 and the Status output = 1, then the Enabled output = 1.
Status	Data type: Boolean The output indicates whether the EDM feedback signal input has switched correctly after a change in the Enabled output. <ul style="list-style-type: none"> • If an error occurs, then the Status output = 0 • If a valid reset condition is present, then the Status output = 1.

Table 87: Parameter External device monitoring V1

Parameter	Description
Max. feedback delay	1 ms ... 60 s Maximum permitted delay until the feedback signal = 1. Values that are not a multiple of the logic execution time are rounded to the nearest multiple of the logic execution time.
EDM operating mode	<ul style="list-style-type: none"> • Switch-on monitoring If a rising edge of the Enabled output is present, the function block monitors whether the EDM feedback signal input switches to 0 within the configured Max. feedback delay. • Switch-on and switch-off monitoring In addition to operating mode Switch-on monitoring: If a falling edge of the Enabled output is present, the function block monitors whether the EDM feedback signal input switches to 1 within the configured Max. feedback delay.

Parameter	Description
Permanent monitoring of the feedback signal	<p>When this option is selected, the function block monitors whether the EDM feedback signal input has assumed the expected value after the feedback delay has elapsed and also whether the value has changed again after the max. feedback delay has elapsed.</p> <p>This enables undesired signal changes of the connected device to be identified even if the device already switched correctly.</p> <p>Monitoring depending on the EDM operating mode parameter:</p> <ul style="list-style-type: none"> • Switch-on monitoring A rising edge at the EDM feedback signal input is not allowed after the max. feedback delay has elapsed while the Control input input = 1. • Switch-on and switch-off monitoring In addition to operating mode Switch-on monitoring: A falling edge at the EDM feedback signal input is not allowed after the max. feedback delay has elapsed while the Control input input = 0. <p>If an undesired signal change occurs, then the Status output switches to 0. The same reset conditions apply as for errors during the configured feedback delay time.</p>

Errors and reset conditions

Table 88: Errors and reset conditions

Applies to EDM operating mode		Error	Reset condition
Switch-on monitoring	Switch-on and switch-off monitoring		
Yes	Yes	The EDM feedback signal input \neq 1 while the Control input input is set to 1.	The Control input input = 0 or EDM feedback signal input = 1
Yes	Yes	After the Control input input = 1, the EDM feedback signal input does not switch to 0 within the configured feedback delay time.	Control input input = 0
No	Yes	After the Control input input = 0, the EDM feedback signal input does not switch to 1 within the configured feedback delay time.	The EDM feedback signal input = 1 for the duration of the configured feedback time, and the Control input input must be = 0 at the latest by expiry of the feedback delay time.

Sequence/timing diagram

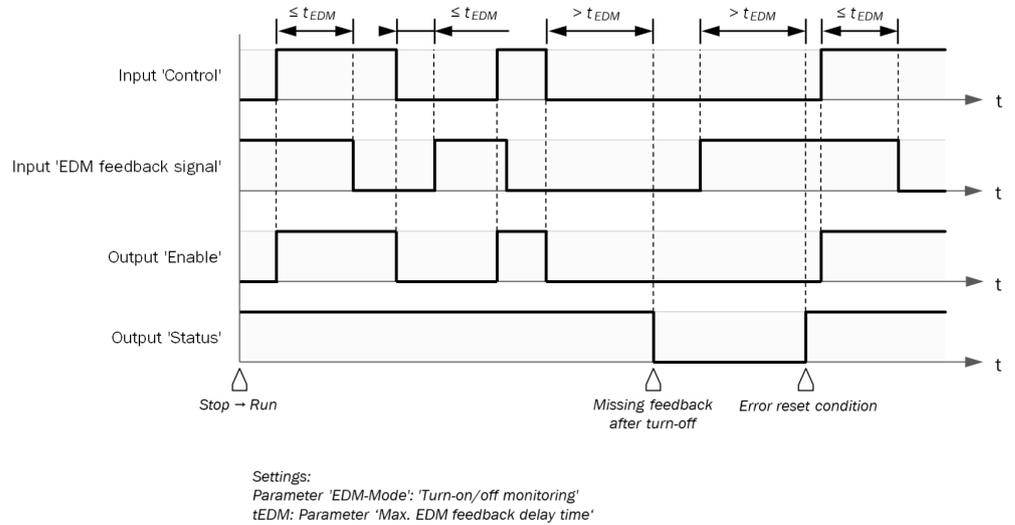

Figure 36: Sequence/timing diagram External device monitoring V1 without parameter Permanent monitoring of the feedback signal

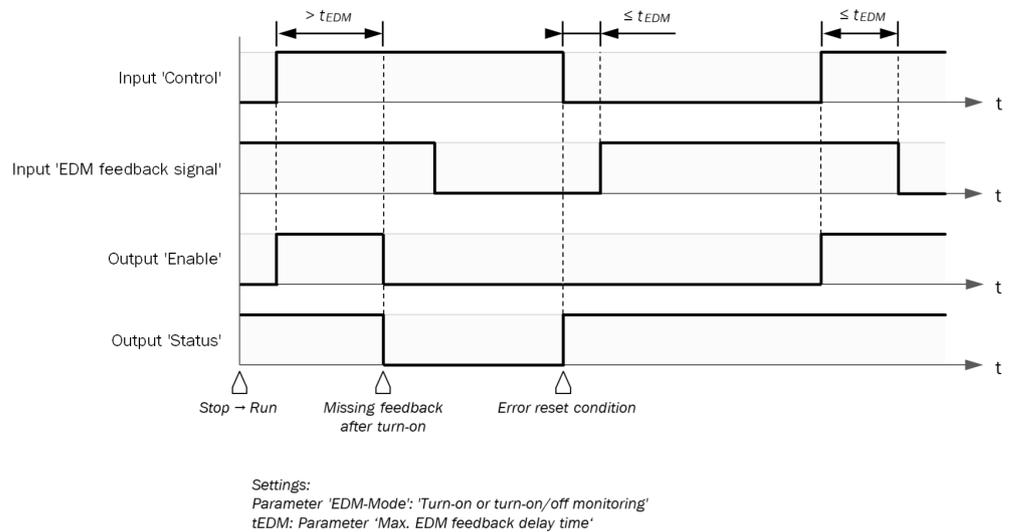

Figure 37: Sequence/timing diagram External device monitoring V1 without parameter Permanent monitoring of the feedback signal

Complementary information

The total delay time of the feedback signal is determined by the:

- Signal propagation time between the Enabled output and the physical input of the external device
- Switching time of the external device
- Signal propagation time of the external device and the EDM feedback signal input

If you need the signal at the Enabled output to be delayed, you must implement this delay time by using another function block that is located upstream of the External device monitoring V1 function block. Otherwise, errors may result.

7.7.2.5.2 Fast shut off V1

Overview

The function block minimizes the switch-off time of a safety switching path. The switch-off time depends on the logic execution time. The switching on again of the output depends on the logic execution time.

You can implement a simple logic within the function block. The function block also provides the option to implement a bypass to bridge the fast shut off function.

Important information**WARNING**

Restricted safety with bypass

In the case of non-compliance, it is possible that the dangerous state of the machine may not be stopped or not stopped in a timely manner.

- ▶ Make sure that the system or machine is in a safe status when using the Bypass function.
- ▶ Ensure the mandatory use of other protective measures while the Bypass function is active, e.g., that the machine is in safe setup mode so that it cannot endanger people or parts of the system while the bypass is active.
- ▶ Take into account the longer response time when the bypass is deactivated when planning the application.

Prerequisites

- All relevant physical inputs and outputs for the **Fast shut off V1** function block are connected to the same module.
- Relevant input elements are connected directly to the inputs 1 ... 8 of the function block. There must be no logic between the input elements and the inputs on the function block.
- The outputs of the function block must have a direct switch-off effect on the output element. The downstream logic must not contain any **OR V1** function block.

Principle of operation

Table 89: Inputs Fast shut off V1

Input	Description
Input 1	Data type: Boolean
Input 2 ... Input 8 (optional)	
Bypass (optional)	Data type: Boolean

Table 90: Outputs Fast shut off V1

Output	Description
Output	Data type: Boolean Depends on the Bypass parameter and the internal logic. You need to first connect the associated inputs to the input elements before the output can be configured.

Table 91: Parameter Fast shut off V1

Parameter	Description
Number of inputs (I/O settings tab)	1 ... 8

Parameter	Description
Bypass (I/O settings tab)	Bypass bridges the fast shut off function with the help of the Bypass input. If the Bypass input = 1, then Output remains = 1 and the physical output = High.
Internal logic (Parameter tab)	You can configure the internal logic of the function block.

Configuring the internal logic

The function block has an internal logic that comprises two AND gates (enable condition A and B) and an OR gate. The associated output is set to 1 if all conditions for A or B are met:

Conditions for A

- At least one input is activated for **Release Condition A**.
- All activated inputs of **Release Condition A** = 1.

Conditions for B

- At least one input is activated for **Release Condition B**.
- All activated inputs of **Release Condition B** = 1.

Example of two alternative enable conditions

A safety light curtain with presence detection is protecting the work cell of a robot. The movement of the robot is enabled as long as the safety light curtain (sensor A) is not interrupted. If the safety light curtain is interrupted, the robot movement is only enabled if the robot is located in a non-dangerous position (sensor B), e.g., in an offline position. Either sensor A or sensor B must enable the robot movement.

Either sensor A or sensor B must release the robot movement.

An OR relationship of condition A and condition B can be used to configure these alternative enable conditions.

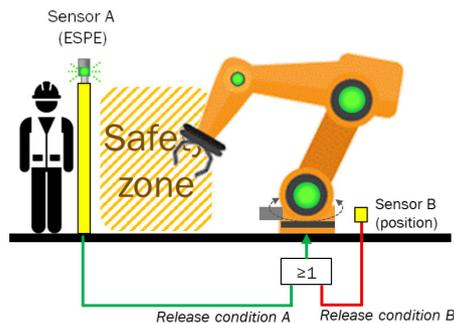

Figure 38: Release condition A is fulfilled. Robot movement is released.

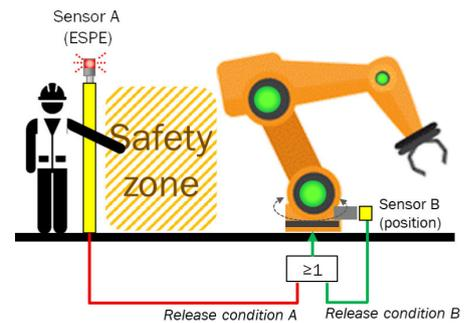

Figure 39: Release condition B is fulfilled. Robot movement is released.

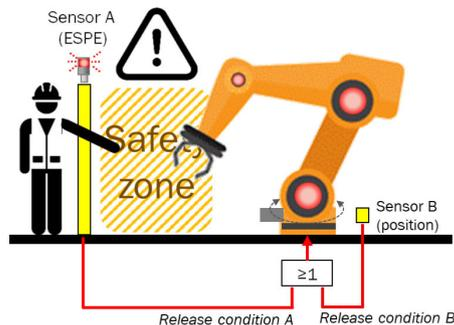

Figure 40: Release condition A and B are fulfilled. Robot movement is not released.

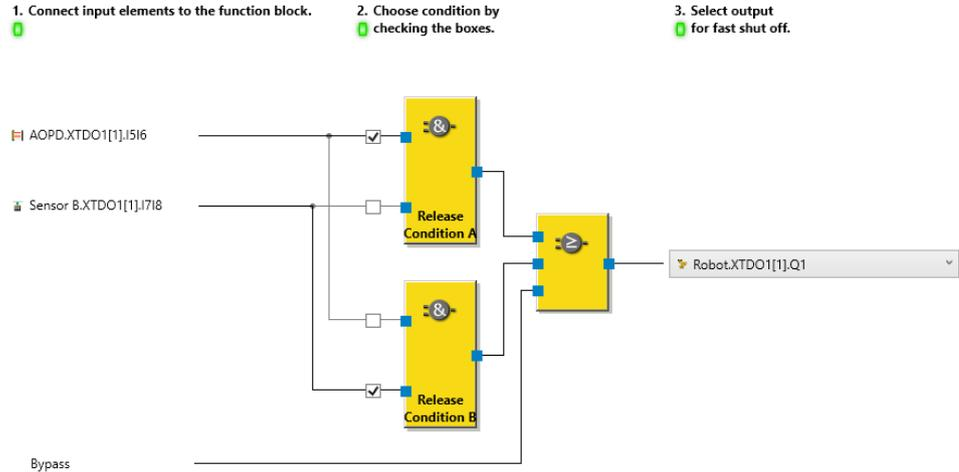

Figure 41: Example of Fast shut off V1 internal logic for alternative enable conditions

Examples for the use of bypass

- Operation of a machine or system in **Setup** mode (bypass is activated, for example, using an enabling pushbutton)
- Muting during the upwards movement of a press (bypass is activated with the help of a press signal)

Response time

Table 92: Response times

Input	Response time for switch-off	Response time for switch-on
Input 1 ... Input 8	Fast shut off response time	No effect on the response time → Normal response time
Bypass	No effect on the response time → Normal response time	Normal response time + switch-on delay of 3 logic cycles The switch-on delay compensates for the processing time of the logic. To bypass fast shut off, the Bypass input must be set to 1 at least 3 logic cycles in advance in the logic before the input signal changes to 0 on the physical input.

Complementary information

- The value of the connected output in the online monitor of the logic may deviate from the actual value of the physical output.

Further topics

- ["Maximum response time", page 135](#)

7.7.2.6 Function blocks for applications

7.7.2.6.1 Reset V1

Overview

You can use this function block to implement a reset function.

The function block makes it possible to acknowledge a manual safety stop and subsequently restart the application.

Important information



WARNING

Undesired reset following short-circuit to High

The dangerous state may not be stopped or not be stopped in a timely manner in the event of non-compliance.

- ▶ Make sure the signal line is laid with protection (to prevent a cross-circuit with other signal lines).
- ▶ No short-circuit detection, i.e., no referencing to test outputs.

Principle of operation

Table 93: Inputs Reset V1

Input	Description
Reset	Data type: Boolean For connecting a reset command switch. A valid reset sequence comprises the signal sequence 0-1-0. Pulse duration: 100 ms ... 30 s, at least 2 × logic execution time
Release	Data type: Boolean See Enabled output.

Table 94: Outputs Reset V1

Output	Description
Enabled	Data type: Boolean Resets the safety device. <ul style="list-style-type: none"> • When the Release input = 1 and the function block detects a valid reset pulse on the Reset input, the Enabled output switches to 1. • The Release output remains = 1 as long as the Enabled input = 1.
Reset required	Data type: Boolean The output pulsates at 1 Hz to indicate that the function block is expecting a valid reset pulse at the Reset input so that the Enabled output can switch to 1. When the Release input = 1 and the function block detects a rising signal edge at the Reset input, the Ready for reset output switches permanently to 1. You can use this output to control an indicator lamp.
Ready for reset	Data type: Boolean The output switches to 1 when a valid pulse at the Reset input leads to activation of the Enabled output.

Sequence/timing diagram

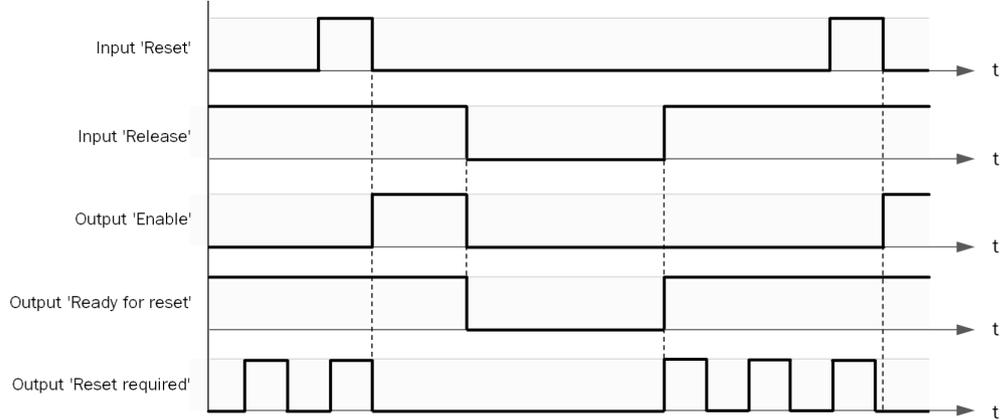

Figure 42: Sequence/timing diagram Reset V1

Complementary information

To evaluate the minimum length of the reset pulse (here: 100 ms), the reset signal must be sampled twice after a 0→1 transition is detected. The required minimum length of the reset signal is therefore extended by one logic execution time.

Further topics

- ["Single-channel use of safety inputs", page 30](#)

7.7.2.6.2

Restart V1 (Restart)

Overview

You can use this function block to implement a restart function.

The function block makes it possible to acknowledge a manual safety stop and subsequently restart the application.

Important information



WARNING

Undesired reset following short-circuit to High

The dangerous state may not be stopped or not be stopped in a timely manner in the event of non-compliance.

- ▶ Make sure the signal line is laid with protection (to prevent a cross-circuit with other signal lines).
- ▶ No short-circuit detection, i.e., no referencing to test outputs.

Principle of operation

Table 95: Inputs Restart V1

Input	Description
Restart	Data type: Boolean For connecting a restart command switch. A valid restart sequence comprises the signal sequence 0-1-0. Pulse duration: 100 ms ... 30 s, at least 2 × logic execution time
Release	Data type: Boolean See Enabled output.

Table 96: Outputs Restart V1

Output	Description
Enabled	Data type: Boolean Resets the safety device. <ul style="list-style-type: none"> When the Release input = 1 and the function block detects a valid restart pulse on the Restart input, the Enabled output switches to 1. The Enabled output remains = 1 as long as the Enable input = 1.
Restart required	Data type: Boolean The output pulsates at 1 Hz to indicate that the function block is expecting a valid restart pulse at the Restart input so that the Enabled output can switch to 1. When the Release input = 1 and the function block detects a rising signal edge at the Restart input, the Restart required output switches permanently to 1. You can use this output to control an indicator lamp.
Ready for restart	Data type: Boolean The output switches to 1 when a valid pulse at the Restart input leads to activation of the Enabled output.

Sequence/timing diagram

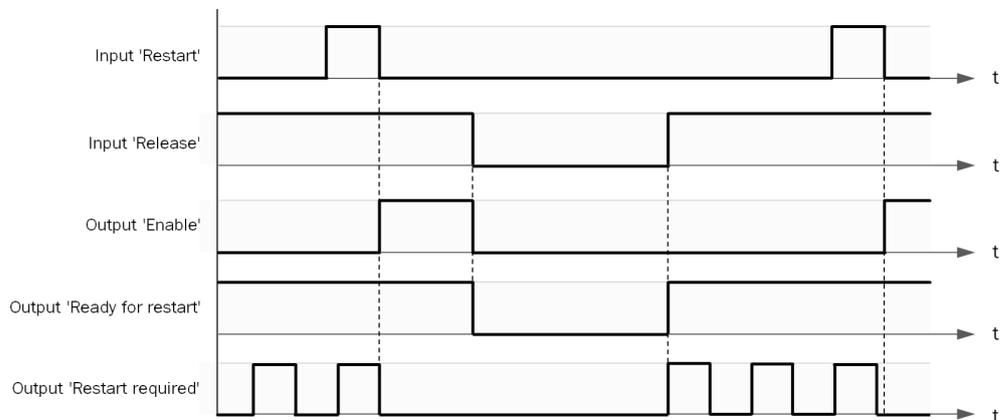

Figure 43: Sequence/timing diagram Restart V1

Complementary information

To evaluate the minimum length of the restart pulse (here: 100 ms), the restart signal must be sampled twice after a 0→1 transition is detected. The required minimum length of the restart signal is therefore extended by one logic execution time.

Further topics

- ["Single-channel use of safety inputs", page 30](#)

7.7.2.6.3

Multi operator V1

Overview

You can use this function block to operate up to three two-hand control devices at the same time (e.g., for press applications with more than one operator).

Important information



WARNING

Ineffectiveness of the protective device

The function block does not perform a dual-channel evaluation or two-hand monitoring of the inputs. The dangerous state may not be stopped or not be stopped in a timely manner in the event of non-compliance.

- ▶ Only connect safe signals that have undergone a preliminary evaluation to the **Operator 1 ... Operator 3** inputs. This can be, for example, the **Enabled** output of a two-hand control function block.

Principle of operation

Table 97: Inputs Multi operator V1

Input	Description
Operator 1 Operator 2 Operator 3 (optional)	Data type: Boolean
Release 1 Release 2 (optional)	Data type: Boolean The function block uses the inputs to check whether specific prerequisites have been met (e.g., protective device closed, safety light curtain active, etc.).
Cycle request	Data type: Boolean A cycle request prevents one or more of the two-hand control devices from remaining permanently actuated. For this purpose, the function block requires a signal that, for example, generates a pulse during each machine cycle. Do not use this input for safety functions, but instead for, e.g. automation control.

Table 98: Outputs Multi operator V1

Output	Description
Enabled	Data type: Boolean The output switches to 1 if all of the following conditions are met: <ul style="list-style-type: none"> • The Release 1 and Release 2 inputs are and remain set to 1. • All connected Operator 1 ... Operator 3 inputs change from 0 to 1 (rising signal edge). • No rising or falling signal edge is detected at the Cycle request input during or after the Operator 1 ... Operator 3 inputs change from 0 to 1. The output switches to 0 if one or more of the following conditions are met: <ul style="list-style-type: none"> • At least one connected Release 1 ... Release 2 input = 0. • At least one connected Operator 1 ... Operator 3 input = 0. • A rising or falling signal edge is detected at the Cycle request input. During the first logic cycle, the Enabled output = 0.

Table 99: Parameter Multi operator V1

Parameter	Description
Cycle request condition	<ul style="list-style-type: none"> • Rising signal edge • Falling signal edge
Number of operators	<ul style="list-style-type: none"> • 2 operators • 3 operators

Parameter	Description
Number of release inputs	0 ... 2

Sequence/timing diagram

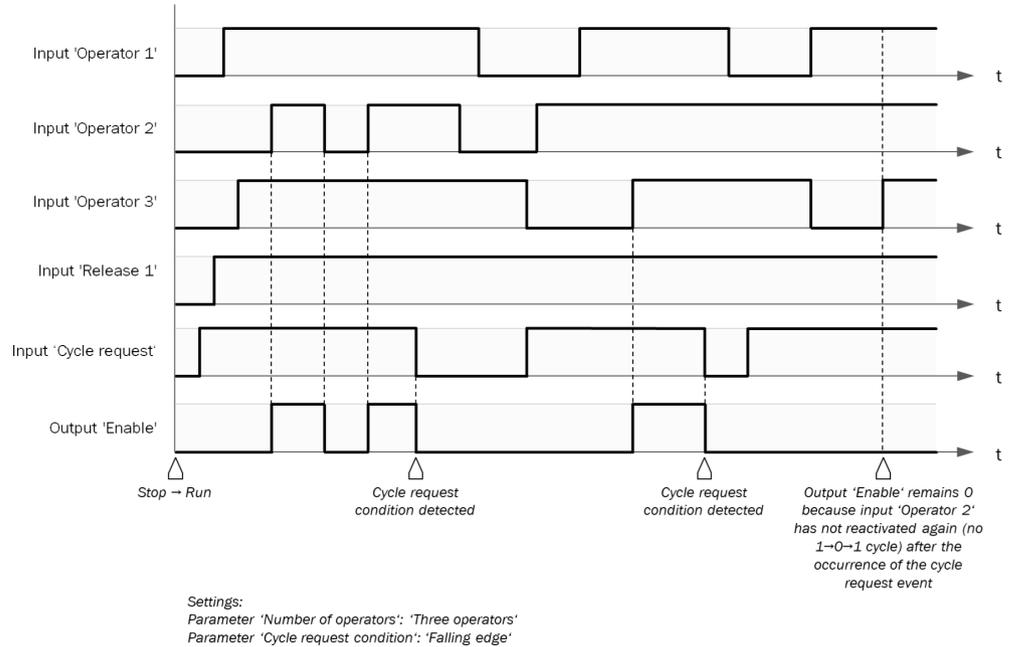

Figure 44: Sequence/timing diagram Multi operator V1

7.7.2.6.4

Operating mode switch V1

Overview

This function block selects an output based on an input value.

Principle of operation

Table 100: Inputs Operating mode switch V1

Input	Description
Input 1	Data type: Boolean
Input 2	See Output 1 ... Output 8.
Input 3 ... Input 8 (optional)	

Table 101: Outputs Operating mode switch V1

Output	Description
Output 1 ... Output 8	Data type: Boolean If exactly one input $x = 1$, then output $x = 1$. Example: <ul style="list-style-type: none"> Input 2 = 1 and all other inputs = 0, then output 2 = 1. Input 5 = 1 and all other inputs = 0, then output 5 = 1. The behavior of the outputs also depends on the configured parameters.
Operating mode unchanged	Data type: Boolean The output is 0 for the duration of a logic cycle if the value of at least one output changed during the last logic cycle.

Output	Description
Status	Data type: Boolean <ul style="list-style-type: none"> Output = 0, if the error output combination is active. Output = 1, if exactly one input is 1.

Table 102: Parameter Operating mode switch V1

Parameter	Description
Number of inputs	2 ... 8
Discrepancy time	0 ... 10 s in 1 ms increments The discrepancy time defines how long the two inputs can continue to have discrepant values after a change in either of the input signals without this being regarded as an error.
Error output combination	If no input = 1 or more than one input = 1 for the selected discrepancy time, the function block sets its outputs to the configured error output combination. Selected outputs switch to 1, and non-selected outputs switch to 0. For unused inputs (Number of inputs parameter), the corresponding value in the error output combination is set to 0. When a valid input combination is present again, the function block sets to 1 the output corresponding to the input. If a faulty input combination is already present in the first logic cycle, the error output combination is activated without delay.

Behavior of the function block

- Exactly one input must be = 1 at all times.
- If more than one input or no input is set to 1, the last output set to 1 remains 1 for the duration of the set discrepancy time. The **Status** output is 1.
- If no input or more than one input = 1 after the discrepancy time elapses, the outputs 1 ... 8 are set to the configured error output combination. The **Status** output is 0.

Sequence/timing diagram

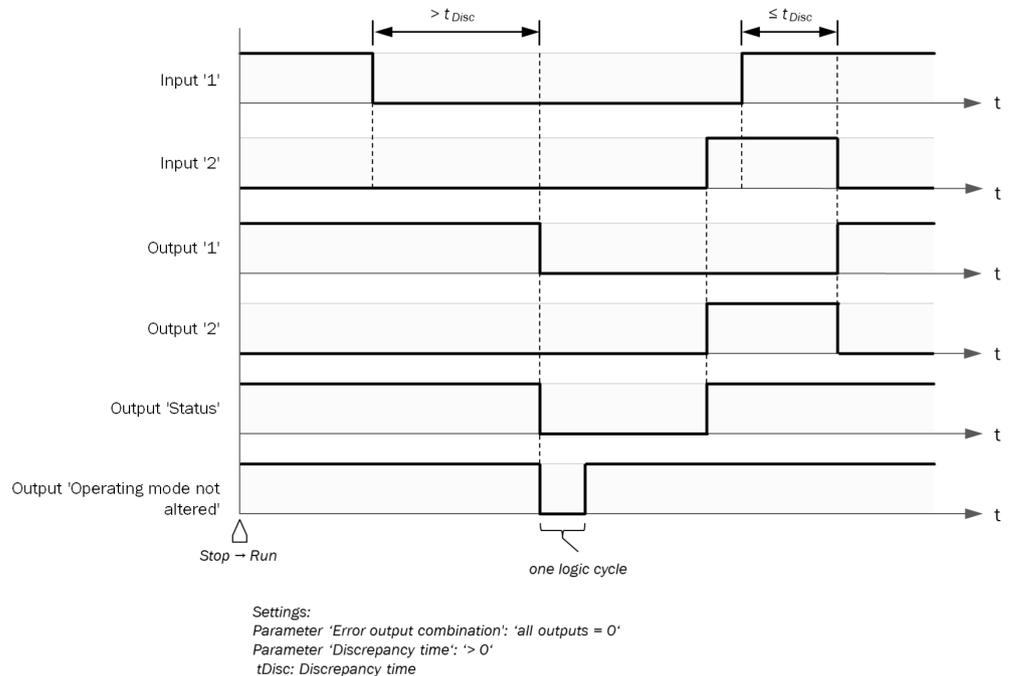

Figure 45: Sequence/timing diagram Operating mode switch V1

7.7.2.6.5 Multi enable V1

Overview

Each input of the function block is separately linked to the **Release** input via AND logic. If **Input n** and the **Release** input = 1, then **Output n = 1**.

Principle of operation

Table 103: Inputs Multi enable V1

Input	Description
Input 1	Data type: Boolean
Input 2 ... Input 8 (optional)	
Release	Data type: Boolean

Table 104: Outputs Multi enable V1

Output	Description
Output 1 ... Output 8	Data type: Boolean If Input n and the Release input = 1, then Output n = 1

Table 105: Parameter Multi enable V1

Parameter	Description
Available Inputs	1 ... 8
Inverted	You can individually invert any visible input. At an inverted input, a 0 works internally in the same way as a 1 and vice versa.

7.7.2.6.6 Multi latch V1

Overview

Depending on the **Set** input, the status of up to 8 inputs can be forwarded or saved at the respective outputs.

Principle of operation

Table 106: Inputs Multi latch V1

Input	Description
Input 1	Data type: Boolean
Input 2 ... Input 8 (optional)	
Set	Data type: Boolean Depending on the Inversion parameter, a rising or a falling signal edge saves the current status of inputs 1 ... 8 at the Set input. The function block also saves the statuses of the inputs when the Set input is already 1 in the first logic cycle.

Table 107: Outputs Multi latch V1

Output	Description
Output 1 ... Output 8	Data type: Boolean <ul style="list-style-type: none"> • If the Set input = 0, the function block forwards the status of the inputs to the corresponding outputs unchanged. • If the Set input changes from 0 → 1, the function block saves the current status of inputs 1 ... 8. The function block outputs the saved status to the outputs as long as the Set input = 1. The status change of inputs 1 ... 8 does not influence the outputs as long as the Set input = 1.

Table 108: Parameter Multi latch V1

Parameter	Description
Available Inputs	1 ... 8
Inverted	<ul style="list-style-type: none"> Input 1 ... Input 8 You can individually invert any visible input. At an inverted input, a 0 works internally in the same way as a 1 and vice versa. Input Set No inversion: Saving done with rising signal edge. With inversion: Saving done with falling signal edge.

7.7.2.7 Function blocks for muting

Muting is an automated process that temporarily bypasses safety functions of a control system or protective equipment. Muting allows certain objects (e.g., pallets loaded with material) to pass through electro-sensitive protective equipment (ESPE) such as a safety light curtain and into a hazardous area. During this transport operation, the Muting function bypasses monitoring by the electro-sensitive protective equipment.

7.7.2.7.1 Parallel muting V1

Overview

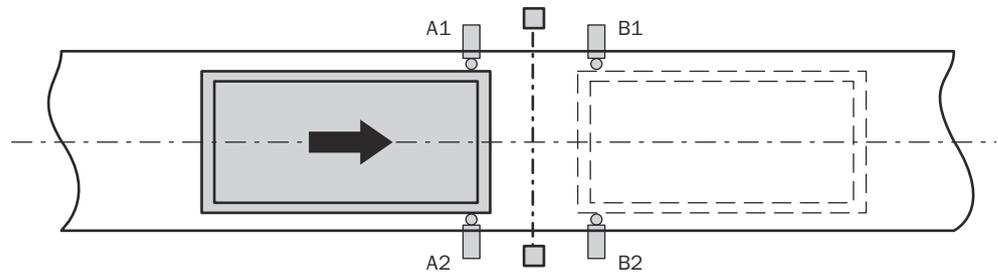

Figure 46: Muting with two sensor pairs arranged in parallel (A1 / A2 and B1 / B2)

Principle of operation

Table 109: Inputs Parallel muting V1

Input	Description
Electro-sensitive protective device	Data type: Boolean The input must be connected to the electro-sensitive protective device.
A1 A2 B1 B2	Data type: Boolean Signal from the muting sensor
Override (optional)	Data type: Boolean "Override input", page 104
Conveyor (optional)	Data type: Boolean "Conveyor input", page 107

Input	Description
C1 (optional)	<p>Data type: Boolean</p> <p>The optional C1 input can be used as additional protection against manipulation. If it is used, the C1 input must have switched to 0 after a previous muting cycle, and to 1 at the latest when both muting sensor signal inputs switch to 1 at the same time. A failure to meet this condition results in a muting error, which is indicated at the Muting error output.</p> <p>The C1 input must then switch back to 0 before the subsequent muting cycle is permitted. The C1 input is not relevant for the duration of the muting status.</p>

Table 110: Outputs Parallel muting V1

Output	Description
Enabled	Data type: Boolean
Muting lamp	<p>Data type: Boolean</p> <p>The Muting lamp output can be used to indicate when a muting cycle is active.</p> <ul style="list-style-type: none"> • The Muting lamp output = 0 if the Muting status output = 0 • The Muting lamp output = 1 if the Muting status output = 1 or the Override status output = 1 • The Muting lamp output pulsates at 2 Hz if the Override required output = 1
Muting status	<p>Data type: Boolean</p> <p>The output indicates the status of the muting function.</p> <ul style="list-style-type: none"> • The Muting status output = 0 if the muting cycle is inactive (no error) or a muting error has been detected • The Muting status output = 1 if the muting cycle is active (no error) or override is active (no error)
Override required	Data type: Boolean
Muting error	Data type: Boolean "Muting error output", page 107
Override status	Data type: Boolean
Status	<p>Data type: Boolean</p> <ul style="list-style-type: none"> • 0 = Error • 1 = No error <p>The value at the output is the inverted value of the Muting error output.</p>

Table 111: Parameter Parallel muting V1

Parameter	Description
Direction detection	<ul style="list-style-type: none"> • Disabled • Forward (A1/A2 first) (A1 / A2 first) • Backward (B1/B2 first) (B1 / B2 first) <p>"Parameter Direction detection", page 108</p>
Condition of the other sensor pair for muting start	<ul style="list-style-type: none"> • Both sensors are free • At least one sensor is free <p>"Condition of other sensor pair for muting start parameter", page 109</p>
Condition for end of muting	<ul style="list-style-type: none"> • With muting sensor pair • With electro-sensitive protective equipment (ESPE) <p>"Muting end condition parameter", page 109</p>

Parameter	Description
Total muting time	0 = infinite, 5 s ... 3,600 s, adjustable in 1 s increments "Total muting time parameter ", page 109
Concurrency monitoring time	0 = infinite, 10 ms ... 3,000 ms, adjustable in 10 ms increments. If the value is not 0, it must be greater than the logic execution time. "Parameter Concurrency monitoring time", page 108
Suppression of sensor signal gaps	0 = infinite, 10 ms ... 1,000 ms, adjustable in 10 ms increments. If the value is not 0, it must be greater than the logic execution time. see "Parameter Suppression of sensor signal gaps", page 108
Additional muting time after the ESPE is released	0 ms, 200 ms, 500 ms, 1,000 ms "Additional muting time after the electro-sensitive protective device indicates a clear path parameter", page 109
Input C1	<ul style="list-style-type: none"> Active Deactivated
Override input	<ul style="list-style-type: none"> Active Deactivated
Conveyor	<ul style="list-style-type: none"> Active Deactivated

Sequence/timing diagram

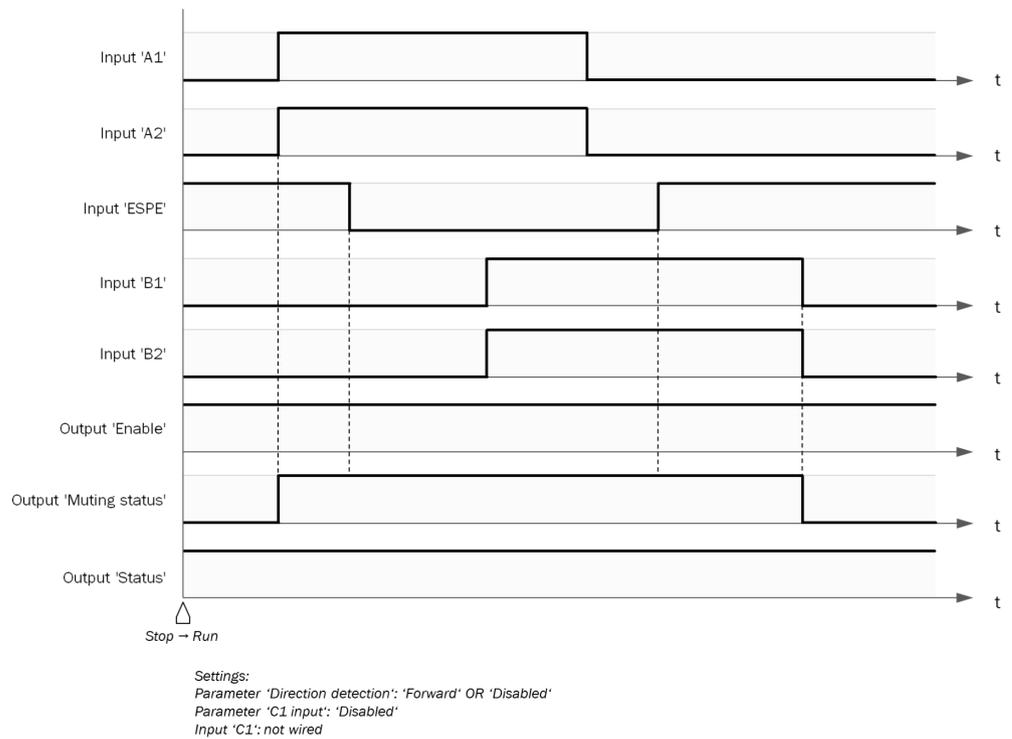

Figure 47: Sequence/timing diagram Parallel muting V1

Complementary information

- If there are objects in the area of the muting sensors during the first logic cycle and therefore one or more muting sensor signal inputs are set to 1, this generates a muting error. The signaling of the error state at the **Muting error** output is suppressed if the **BWS** input = 1. Before a new valid muting cycle can be executed, this error must be reset.
- The muting times have an accuracy of ± 10 ms (evaluation plus logic execution time).

Further topics

- ["Safety notes for muting applications", page 19](#)

7.7.2.7.2

Sequential muting V1

Overview

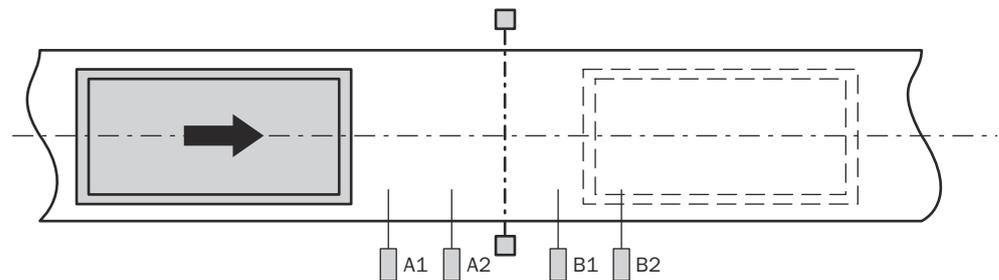

Figure 48: Muting with two sensor pairs arranged in sequence (A1 / A2 and B1 / B2)

Principle of operation

Table 112: Inputs Sequential muting V1

Input	Description
Electro-sensitive protective device	Data type: Boolean The input must be connected to the electro-sensitive protective device.
A1 A2 B1 B2	Data type: Boolean Signal from the muting sensor
Override (optional)	Data type: Boolean "Override input", page 104
Conveyor (optional)	Data type: Boolean "Conveyor input", page 107
C1 (optional)	Data type: Boolean The optional C1 input can be used as additional protection against manipulation. If it is used, the C1 input must have switched to 0 after a previous muting cycle, and to 1 at the latest when both muting sensor signal inputs switch to 1 at the same time. A failure to meet this condition results in a muting error, which is indicated at the Muting error output. The C1 input must then switch back to 0 before the subsequent muting cycle is permitted. The C1 input is not relevant for the duration of the muting status.

Table 113: Outputs Sequential muting V1

Output	Description
Enabled	Data type: Boolean

Output	Description
Muting lamp	Data type: Boolean The Muting lamp output can be used to indicate when a muting cycle is active. <ul style="list-style-type: none"> The Muting lamp output = 0 if the Muting status output = 0 The Muting lamp output = 1 if the Muting status output = 1 or the Override status output = 1 The Muting lamp output pulsates at 2 Hz if the Override required output = 1
Muting status	Data type: Boolean The output indicates the status of the muting function. <ul style="list-style-type: none"> The Muting status output = 0 if the muting cycle is inactive (no error) or a muting error has been detected The Muting status output = 1 if the muting cycle is active (no error) or override is active (no error)
Override required	Data type: Boolean
Muting error	Data type: Boolean "Muting error output", page 107
Override status	Data type: Boolean
Status	Data type: Boolean <ul style="list-style-type: none"> 0 = Error 1 = No error <p>The value at the output is the inverted value of the Muting error output.</p>

Table 114: Parameter Sequential muting V1

Parameter	Description
Direction detection	<ul style="list-style-type: none"> Disabled Forward (A1 / A2 first) Backward (B1 / B2 first) "Parameter Direction detection", page 108
Condition of the other sensor pair for muting start	<ul style="list-style-type: none"> Both sensors clear At least one sensor clear "Condition of other sensor pair for muting start parameter", page 109
Condition for end of muting	<ul style="list-style-type: none"> With muting sensor pair With electro-sensitive protective device (ESPE) "Muting end condition parameter", page 109
Total muting time	0 = infinite, 5 s ... 3,600 s, adjustable in 1 s increments "Total muting time parameter", page 109
Concurrency monitoring time	0 = infinite, 10 ... 3,000 ms, adjustable in 10 ms increments. If the value is not 0, it must be greater than the logic execution time. "Parameter Concurrency monitoring time", page 108

Parameter	Description
Suppression of sensor signal gaps	0 = infinite, 10 ms ... 1,000 ms, adjustable in 10 ms increments. If the value is not 0, it must be greater than the logic execution time. see "Parameter Suppression of sensor signal gaps", page 108 To avoid machine downtimes during sequential muting, the configured time for Suppression of sensor signal gaps should be less than the length of time between deactivation of the first sensor and deactivation of the second sensor of a muting sensor pair (e.g., A1 / A2 or B1 / B2) when the transported material leaves the range of this sensor pair. Otherwise, the signal of the first sensor is still active at the time of deactivation of the second sensor due to the Suppression of sensor signal gaps and an error occurs in the sequence monitoring.
Additional muting time after the ESPE is released	0 ms, 200 ms, 500 ms, 1,000 ms "Additional muting time after the electro-sensitive protective device indicates a clear path parameter", page 109
Input C1	<ul style="list-style-type: none"> Active Deactivated
Override input	<ul style="list-style-type: none"> Active Deactivated
Conveyor	<ul style="list-style-type: none"> Active Deactivated

Sequence/timing diagram

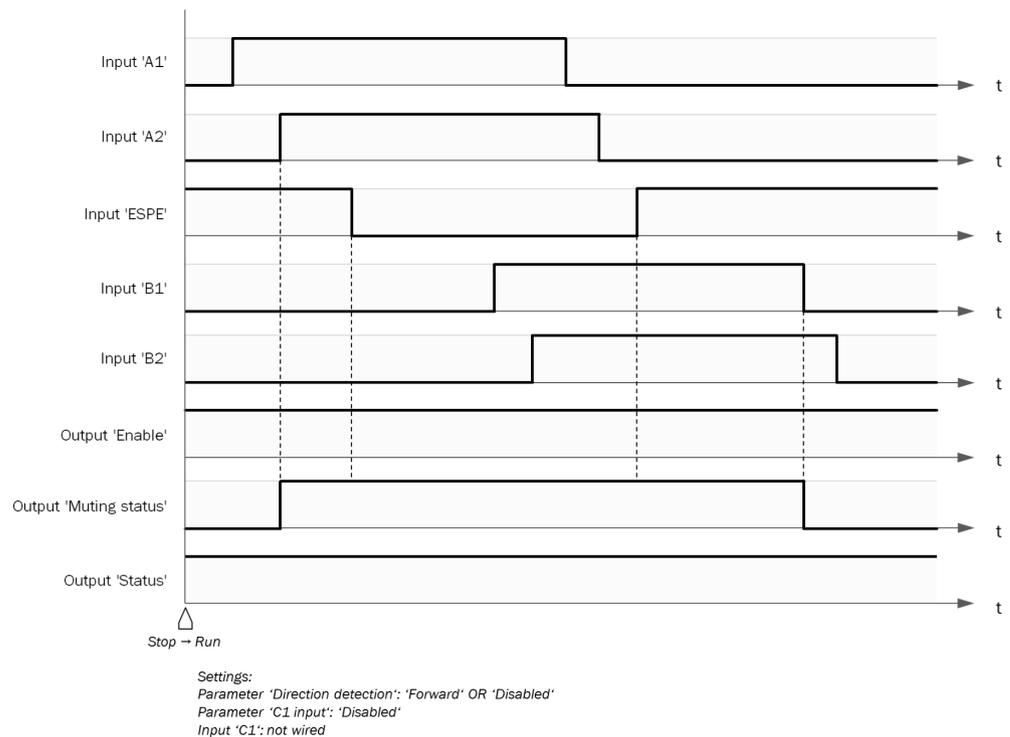

Figure 49: Sequence/timing diagram Sequential muting V1

Sequence monitoring

A sequence monitoring is performed when sequential muting is active. The prerequisite for sequence monitoring and the initiation of muting is a prescribed activation sequence of the muting sensors.

Table 115: Valid sequence for muting sensor input signals with sequence monitoring

Direction detection	Valid sequence for muting sensor input signals
Forward	A1 before A2 before B1 before B2
Backward	B2 before B1 before A2 before A1

Deviations from the sequence result in a muting error, which is indicated at the **Muting error** output. This applies both to the sequence of activation (muting sensor signal inputs switch from 0 to 1) and to deactivation (muting sensor signal inputs switch from 1 to 0).

Complementary information

- If there are objects in the area of the muting sensors during the first logic cycle and therefore one or more muting sensor signal inputs are set to 1, this generates a muting error. The signaling of the error state at the **Muting error** output is suppressed if the **BWS** input = 1. Before a new valid muting cycle can be executed, this error must be reset.
- The muting times have an accuracy of ± 10 ms (evaluation plus logic execution time).

Further topics

- ["Safety notes for muting applications", page 19](#)

7.7.2.7.3

Cross muting V1

Overview

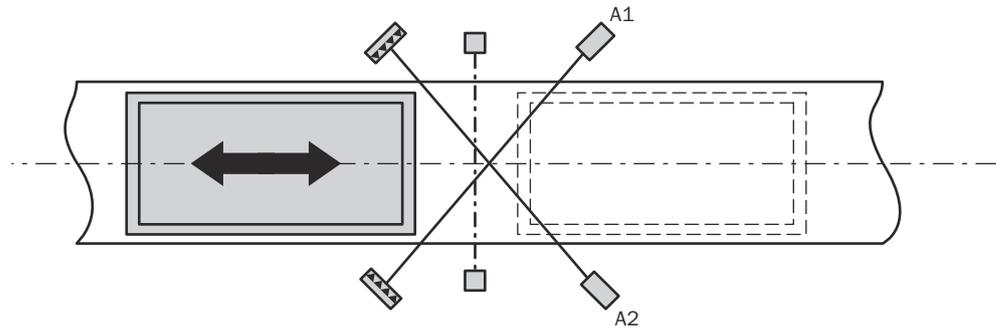

Figure 50: Muting with a sensor pair arranged crosswise (A1 / A2)

Principle of operation

Table 116: Inputs Cross muting V1

Input	Description
Electro-sensitive protective device	Data type: Boolean The input must be connected to the electro-sensitive protective device.
A1 A2	Data type: Boolean Signal from the muting sensor
Override (optional)	Data type: Boolean "Override input", page 104
Conveyor (optional)	Data type: Boolean "Conveyor input", page 107

Input	Description
C1 (optional)	<p>Data type: Boolean</p> <p>The optional C1 input can be used as additional protection against manipulation. If it is used, the C1 input must have switched to 0 after a previous muting cycle, and to 1 at the latest when both muting sensor signal inputs switch to 1 at the same time. A failure to meet this condition results in a muting error, which is indicated at the Muting error output.</p> <p>The C1 input must then switch back to 0 before the subsequent muting cycle is permitted. The C1 input is not relevant for the duration of the muting status.</p>

Table 117: Outputs Cross muting V1

Output	Description
Enabled	Data type: Boolean
Muting lamp	<p>Data type: Boolean</p> <p>The Muting lamp output can be used to indicate when a muting cycle is active.</p> <ul style="list-style-type: none"> • The Muting lamp output = 0 if the Muting status output = 0 • The Muting lamp output = 1 if the Muting status output = 1 or the Override status output = 1 • The Muting lamp output pulsates at 2 Hz if the Override required output = 1
Muting status	<p>Data type: Boolean</p> <p>The output indicates the status of the muting function.</p> <ul style="list-style-type: none"> • The Muting status output = 0 if the muting cycle is inactive (no error) or a muting error has been detected • The Muting status output = 1 if the muting cycle is active (no error) or override is active (no error)
Override required	Data type: Boolean
Muting error	Data type: Boolean "Muting error output", page 107
Override status	Data type: Boolean
Status	<p>Data type: Boolean</p> <ul style="list-style-type: none"> • 0 = Error • 1 = No error <p>The value at the output is the inverted value of the Muting error output.</p>

Table 118: Parameter Cross muting V1

Parameter	Description
Condition of the other sensor pair for muting start	<ul style="list-style-type: none"> • Both sensors clear • At least one sensor clear <p>"Condition of other sensor pair for muting start parameter", page 109</p>
Condition for end of muting	<ul style="list-style-type: none"> • With muting sensor pair • With electro-sensitive protective device (ESPE) <p>"Muting end condition parameter", page 109</p>
Total muting time	0 = infinite, 5 s ... 3,600 s, adjustable in 1 s increments "Total muting time parameter ", page 109
Concurrency monitoring time	0 = infinite, 10 ... 3,000 ms, adjustable in 10 ms increments. If the value is not 0, it must be greater than the logic execution time. "Parameter Concurrency monitoring time", page 108

Parameter	Description
Suppression of sensor signal gaps	0 = infinite, 10 ms ... 1,000 ms, adjustable in 10 ms increments. If the value is not 0, it must be greater than the logic execution time. see "Parameter Suppression of sensor signal gaps", page 108
Additional muting time after the ESPE is released	0 ms, 200 ms, 500 ms, 1,000 ms "Additional muting time after the electro-sensitive protective device indicates a clear path parameter", page 109
Input C1	<ul style="list-style-type: none"> Active Deactivated
Override input	<ul style="list-style-type: none"> Active Deactivated
Conveyor	<ul style="list-style-type: none"> Active Deactivated

Sequence/timing diagram

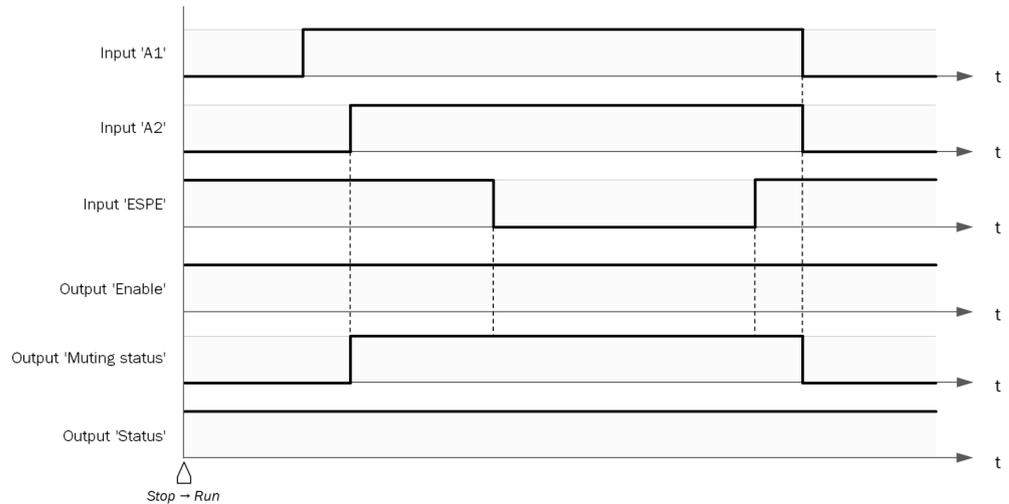

Figure 51: Sequence/timing diagram Cross muting V1

Complementary information

- If there are objects in the area of the muting sensors during the first logic cycle and therefore one or more muting sensor signal inputs are set to 1, this generates a muting error. The signaling of the error state at the **Muting error** output is suppressed if the **BWS** input = 1. Before a new valid muting cycle can be executed, this error must be reset.
- The muting times have an accuracy of ± 10 ms (evaluation plus logic execution time).

Further topics

- ["Safety notes for muting applications", page 19](#)

7.7.2.7.4

Override input

Overview

An **Override** input signal allows you to remove transported objects that have been left stranded in the protective field of the protective device (e.g., safety light curtain) as a result of a power failure, an emergency stop, muting errors, or similar circumstances.

The **Override** function allows you to activate the **Enabled** output of the muting function block even though no valid muting sequence has been detected and the protective device (e.g., safety light curtain) is signaling that a dangerous state may exist. The **Override** input should only be used if the hazardous area has been visually inspected beforehand, there is no one within the hazardous area, and nobody will be able to access the hazardous area while the **Override** input is in use.

Important information



WARNING

Restricted safety with Override

The dangerous state may not be stopped or not be stopped in a timely manner in the event of non-compliance.

- ▶ Only use override if the hazardous area has been visually inspected beforehand, there is no one within the hazardous area, and nobody will be able to access the hazardous area while the **Override** input is in use.

Override

The **Override status output** switches to **1** and the **Override required output** pulsates at **2 Hz** if all of the following conditions are met:

- The **Muting status** output = 0
- At least one of the muting sensor signal inputs **A1, A2, B1, B2** = 1
- The **Electro-sensitive protective device** input = 0 (e.g., safety light curtain has been interrupted)
- The **Enabled** output = 0

If the conditions for the **Override required** output are met and a valid override sequence involving a 0–1–0 transition (at least 100 ms but not exceeding 3 s; longer or shorter pulses will be ignored) occurs at the **Override** input, the **Enabled** output = 1 in exactly the same way as if the muting conditions had been met. Once all the muting sensor signal inputs have switched back to 0 and the **Electro-sensitive protective device** input = 1 (e.g., is indicating that the protective field of a safety light curtain is now clear), the next valid muting cycle is expected. If the next object does not meet the conditions for a muting cycle but does meet the conditions for the **Override required** output, then another override cycle can be used to remove the transported material. The number of override cycles is limited (see table 120, page 106).



NOTE

A reset pushbutton may also be suitable for the **Override** function.

Table 119: Conditions for **Override required** and when **override** is possible

Muting status	At least one of the muting sensor signal inputs A1, A2, B1, B2 = 1	Electro-sensitive protective device input	Override required output	Override possible
0	No	0	0	No
0	No	1	0	No
0	Yes	0	Pulsates (2 Hz)	Yes, unless the maximum permissible number of override cycles has been exceeded.
0	Yes	1	0	No
1	No	0	0	No

Muting status	At least one of the muting sensor signal inputs A1, A2, B1, B2 = 1	Electro-sensitive protective device input	Override required output	Override possible
1	No	1	0	No
1	Yes	0	0	No
1	Yes	1	0	No

Example sequence for **Override** and **Override required**:

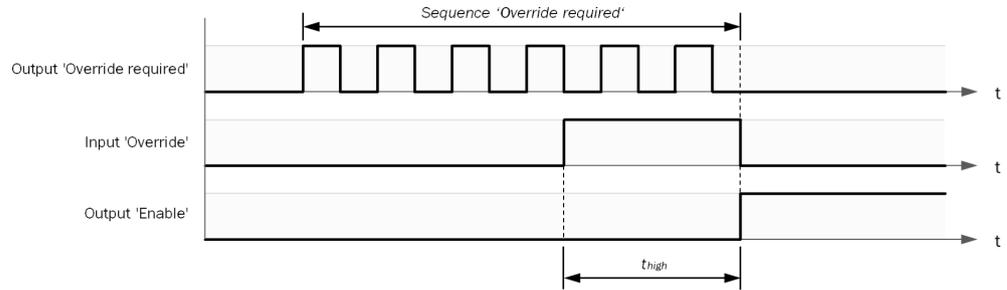

Figure 52: Sequence/timing diagram for **Override** and **Override required**



NOTE

$t_{high} \geq 100 \text{ ms}$, but $\leq 3 \text{ s}$.

Otherwise the pulse on the **Override** input is ignored.

During an override cycle, the **Enabled** output is set to 1 in the same way as during a valid muting sequence. To prevent excessive use of the **Override** function, the number of permissible override cycles is limited. The number of permissible override cycles depends on the value for the total muting time.

Table 120: Number of permissible override cycles

Total muting time	Number of permissible override cycles	Comments
5 s	360	Maximum number of override cycles = 360
10 s	360	
20 s	180	= 60 min/total muting time
30 s	120	
1 min	60	
5 min	12	
15 min	5	Minimum number of override cycles = 5
30 min	5	
60 min	5	
Disabled (0 = unlimited)	5	

The number of override cycles is saved in the function block. This value is incremented whenever the **Override required** output starts pulsating or whenever the **Muting status** output switches to 1. The value is reset to 0 on completion of a valid muting cycle, after a system reset or after a transition from the Stop status to the Run status.

Once the **Override required** output has started pulsating at 2 Hz and a subsequent override signal = 1, muting begins again and the **Enabled** output changes to 1.

If the muting cycle is stopped because of a faulty muting sensor input signal, the **Override required** output switches to 1 for the duration of the logic execution time if the remaining conditions for the **Override required** output are met. If the faulty muting sensor signal input switches back to 1 first and then returns to 0, the muting cycle is once again stopped and the **Override required** output switches to 1 if the remaining conditions for the **Override required** output are met.

While there is a valid override status, none of the following are performed for the duration of one override cycle: direction detection, sequence monitoring (depending on function block) and concurrence monitoring.

Further topics

- ["Single-channel use of safety inputs", page 30](#)

7.7.2.7.5

Conveyor input

Conveyor input

If the transported material stops moving during the muting cycle, the total muting time and other parameters that can lead to muting errors could be exceeded. This problem can be avoided by using the **Conveyor** input. This input allows you to stop the time-dependent functions associated with muting if the material being transported comes to a halt.

- **Conveyor** input is 0: Conveyor system stopped
- **Conveyor** input is 1: Conveyor system running

The following timer functions are affected by the **Conveyor** input:

Table 121: Effect of the Conveyor input

Timer function	Effect of the Conveyor input
Monitoring of the total muting time	<ul style="list-style-type: none"> • The detection of a conveyor system stoppage pauses the timer functions. • When the conveyor system starts up again, the timer continues running with the value that was stored before the stoppage was detected. When this happens for the first time, a one-time increase of 5 seconds is added onto the total muting time.
Concurrence monitoring	

Complementary information

The **Suppression of sensor signal gaps** parameter is not affected by the **Conveyor** input.

7.7.2.7.6

Muting error output

Output Muting error

The **Muting error** output indicates when an error associated with the muting function block has been detected. The **Muting error** output = 1 if the **Electro-sensitive protective device** input = 0 and any muting error has been detected and not yet reset.

Table 122: Error statuses and reset information for muting function blocks

Output Muting error	Resetting the error status	Comments
<ul style="list-style-type: none"> Total muting time monitoring error Concurrence monitoring error Direction detection error Sequence monitoring error Error with transition from Stop status to Run status 	<p>Before a muting error of any kind can be reset, a valid muting cycle must be performed in full. This either involves using the Override function, or all of the muting sensor signal inputs must be set to 1 and the Electro-sensitive protective device input must be set to 0. A valid muting sequence must follow this.</p> <p>When either of these conditions is met, the Muting error output returns to 0 provided that there is no other error pending.</p>	<p>The Enabled output and the Status output switch to 0 if the Muting error output is set to 1.</p>

Complementary information

If the **Electro-sensitive protective device** input = 1, the display of muting errors at the **Muting error** output is suppressed.

7.7.2.7.7

Parameter Direction detection

The **Direction detection** function can be used to tighten muting conditions if the material being transported is only to be moved in one particular direction. The possible movement direction depends on the order in which the muting sensors are activated.

If the **Forward (A1/A2 first)** (A1 / A2 first) direction is selected, the inputs for the muting sensor pairs must be activated in the order A1 / A2 before B1 / B2. Muting is not possible in the opposite direction.

If the **Backward (B1/B2 first)** (B1 / B2 first) direction is selected, the inputs for the muting sensor pairs must be activated in the order B1 / B2 before A1 / A2. Muting is not possible in the opposite direction.

7.7.2.7.8

Parameter Suppression of sensor signal gaps

Occasionally, muting sensors are affected by output signal faults that are of no significance as far as muting is concerned. The **Suppression of sensor signal gaps** function makes it possible to filter out brief faults without interrupting muting.

When the **Suppression of sensor signal gaps** parameter is active, a change of a muting sensor signal input to 0 will be ignored for the length of time that has been set for **Suppression of sensor signal gaps**. The function block continues to interpret this as an uninterrupted 1 signal provided that only one muting sensor signal input from each sensor pair (**A1/A2** or **B1/B2**) is affected by a signal gap.

7.7.2.7.9

Parameter Concurrency monitoring time

Parameter Concurrency monitoring time

This parameter is used to check whether the muting sensors are activated at the same time. This value relates to the two muting sensor signal inputs that are subject to dual-channel evaluation and specifies how long they are allowed to have different values without this being regarded as an error. This means that input pair **A1** and **A2** or the input pair **B1** and **B2** must assume equivalent values before the end of the concurrence monitoring time.

Concurrence monitoring starts as soon as a value of a muting sensor signal input changes for the first time. If the concurrence monitoring time expires and both inputs of an input pair still have different values, an error occurs and the muting sequence is canceled.

If the concurrence monitoring function of at least one input pair detects an error, the function block indicates this by setting the **Muting error** output to 1.

Complementary information

With the Sequential muting V1 function block, it must be taken into account that the two sensors of each pair switch at different times. The difference depends on the distance between the two sensors and on the speed of the material transport.

7.7.2.7.10 Total muting time parameter

This parameter is used to limit the maximum duration of the muting sequence. If the value set for the **Total muting time** parameter is exceeded, the **Muting error** output switches to 1 and the **Enabled** and **Status** outputs switch to 0.

The timer for the **Total muting time** starts running when a valid start condition for muting exists; this is indicated by the **Muting status** output transitioning to 1. The timer for the **Total muting time** stops running and is reset to 0 if the muting sequence is ended again; this is indicated by the **Muting status** output transitioning to 0.

7.7.2.7.11 Additional muting time after the electro-sensitive protective device indicates a clear path parameter

This parameter can be used if the **Muting end condition** parameter has been configured as **With electro-sensitive protective device**. Sometimes, irregularities in the material or transportation equipment may mean that the ESPE cannot always detect the end of muting precisely. If this happens, you can increase the availability of the machine by configuring an additional muting time of up to 1,000 ms.

In this case, the **Additional muting time after the electro-sensitive protective device indicates a clear path** parameter determines the additional muting time once the **Electro-sensitive protective device** input has switched back to 1.

If one of the muting sensors relevant for muting end frees up, the muting sequence is ended immediately, even if the time set for the **Additional muting time after the electro-sensitive protective device indicates a clear path** parameter has not yet expired.

7.7.2.7.12 Muting end condition parameter

This parameter determines when a valid muting status is over:

- **With muting sensor pair:** When a muting sensor signal input in the last muting sensor pair switches to 0 (sensor clear) and the sensor gap monitoring time has expired.
- **With electro-sensitive protective device:** When the **Electro-sensitive protective device** input switches to 1 and therefore indicates that the protective field is clear again.

If the **Electro-sensitive protective device** input switches to 0 at the end of muting (e.g., because the ESPE protective field has been breached) before the next valid muting sequence begins, the **Enabled** output of the function block switches to 0. In this case, the next muting cycle can only begin once the End-of-muting condition has been met.

7.7.2.7.13 Condition of other sensor pair for muting start parameter

This parameter determines when the next valid muting sequence can begin after a previous muting sequence.

Start conditions for muting:

- **Both inputs are clear:** All muting sensor signal inputs = 0 and the **Electro-sensitive protective device** input = 1 (i.e., the protective field is clear).
- **At least one sensor is clear:** All muting sensor signal inputs except the last one = 0, the **Electro-sensitive protective device** input = 1 (i.e., the protective field is clear) and the sensor gap monitoring time has expired.

If a higher throughput is required, it may be advisable to let the next muting sequence begin as soon as the transported material has traveled past the protective device and past all the muting sensors except the last one (i.e., at least one sensor is clear).

7.7.3 Outputs

Output elements

The **Outputs** selection window contains the following output elements:

- Jump addresses
- The module outputs that are in use
- Bits of the input record of a gateway
- Output bits for the logic results

You can use logic results to forward the results of the logic program to other controllers via a network, e.g., using a gateway. You can use each output bit only once.

- CPU marker

Further topics

- ["Jump addresses", page 111](#)
- ["Connecting elements", page 112](#)

7.7.4 Diagnostics

Overview

The process data status bits can be used as input elements for the logic.

Important information



WARNING

Ineffectiveness of the protective device due to the use of non-safe diagnostic data for safety-related applications

The dangerous state may not be stopped or not be stopped in a timely manner in the event of non-compliance.

- ▶ Use non-safe process data status bits for diagnostic purposes only.

Process data status bits of the modules

Table 123: Process data status bits of the modules

Process data status bits	Value	Description
Voltage supply of outputs (for modules with safety outputs only)	0	Voltage supply of the outputs is outside the specified range, fault switch-off due to short-circuit to VCC or cross-circuit to other outputs.
	1	Voltage supply of the output is OK
Input data status	0	One or more input bits of the associated module have been set to 0 because an error has been detected (e.g., cross-circuit or communication error). I.e., the input bits may have different values than would normally be the case during error-free operation.
	1	Inputs of the associated module are OK

Process data status bits	Value	Description
Output data status	0	An error has been detected at one or more outputs of the associated module (e.g., overload, short-circuit or communication error). I.e., the outputs may have different values than would normally be the case during error-free operation.
	1	Outputs of the associated module are OK

Process data status bits of the individual inputs or outputs

Table 124: Process data status bits of the individual inputs or outputs

Process data status bits	Value	Description
Fast shut off control	0	Error or timeout in fast shut-off logic
	1	Fast shut-off logic is OK
Status Ix, Iy Dual-channel evaluation	0	Error at the inputs The input value is 0, regardless of the level at the terminals.
	1	Dual-channel evaluation of Ix/Iy input is OK
Status Ix	0	Error at the input The input value is 0, regardless of the level at the terminals.
	1	Input is OK
Status Qx Short-circuit to High	0	Output voltage level is High instead of Low when the output is "Off". With test pulses, also in case of short-circuits to VCC or cross-circuits to other outputs. All safety outputs of the module are "Off", regardless of the logic result.
	1	Output is OK
Status Qx Short-circuit to Low	0	Output voltage level is Low instead of High when the output is "On". The safety output is "Off", regardless of the logic result.
	1	Output is OK

Further topics

- ["Possible faults", page 125](#)

7.7.5 Jump addresses

Jump addresses

Jump addresses are available as source and destination jump addresses in the logic editor. The destination jump address assumes the same value (1 or 0) as the associated source jump address without a delay. They can be used to do the following, for example:

- Create a reverse path.
- Connect function blocks on different pages of the logic editor.

Complementary information

- You can use up to 256 jump addresses.
- A source jump address can have multiple target jump addresses.

7.7.6 Logic programming in the logic editor

7.7.6.1 Safety

- Take into consideration that in the event of an error being detected, the associated diagnostic elements are set to 0, however the input bits and output bits could have invalid values. Evaluate the associated safe diagnostic elements (yellow), so that the affected output signals can be switched off in the event of an error.
- An error at an input can result in an unexpected rising or falling signal edge. When edge detection is activated, this can lead to undesirable switching behavior. Remember to allow for unexpected rising or falling signal edges when planning your logic.
- The function blocks are executed in a specific sequence during a logic cycle. You can recognize the sequence of execution using the function block index that is displayed at the top of each function block. If a function block uses the signal of another function block with the same or a higher function block index, a so-called reverse path is created. Reverse paths cause a delay in the response time because the output signal of the function block is only updated one logic cycle later. Please take the delayed response time into account when using reverse paths.
- CPU markers cause a delayed response time.
- For pulsed signals, a signal change may be delayed because the signal change can only be taken into consideration by the test pulse in the subsequent logic cycle. The logic execution time itself is not affected by this.

7.7.6.2 Adding an element

Approach

- ▶ In the **CPU logic catalog**, selected the desired element and drag it onto the worksheet using drag and drop.

7.7.6.3 Connecting elements

Approach

1. Click and hold the blue square of an element.
 2. Drag and release the mouse pointer onto another blue square of an element (left side).
- ✓ A connection between the input and output of the elements is indicated by a black line.

Complementary information

- You can only connect inputs to outputs and vice versa. Inputs are the blue squares on the left side of an element. Outputs are the blue squares on the right side of an element.
- You can connect the output of a function block to multiple downstream function blocks.
- You can connect the output of a function block to multiple physical outputs.

7.7.6.4 Configuring function blocks

Approach

1. Double-click on a function block.
- ✓ The configuration dialog for the function block opens.
2. Configure the desired parameters on the tabs of the configuration dialog.

Complementary information

When you click on a function block on the worksheet, the **FB group info** window displays information about the relevant function block.

Further topics

- ["Function blocks", page 60](#)
- ["Logical function blocks", page 60](#)
- ["Function blocks for applications", page 88](#)

7.7.6.5 Testing the logic program**Testing the logic program**

While the configuration is invalid, you will not be able to activate the simulation mode. You will also not be able to transfer the configuration to the safety controller.

Complementary information

The testing of the logic program is not a safety test.

Further topics

- ["Simulation mode", page 114](#)

7.7.7 Logic execution time**Logic execution time**

The logic execution time is the time required to execute one logic cycle.

The logic execution time depends on the type and number of function blocks used. It is a multiple of 4 ms.

The status of the safety controller outputs only changes at the end of a logic cycle. A change in the status of the safety controller inputs only becomes effective at the start of the next logic cycle.

Complementary information

The configuration software displays both the logic execution time as well as the percentage of this time that has actually been used under **FB group info** in the logic editor. If the amount of time used exceeds 100% of the logic execution time, then the logic execution time is automatically increased by 4 ms.

The logic execution time has an accuracy of ± 500 ppm (parts per million).

7.7.8 I/O matrix

The **I/O matrix** tab in the worksheet shows which inputs affect which outputs. You can use the I/O matrix, for example, to check whether the logic program is complete.

- Green field: Input affects output.
- White field: There is no relationship between input and output.

The **I/O matrix** selection window lists all inputs and outputs in the CPU logic catalog. Activated inputs and outputs are displayed in the matrix.

7.7.9 I/O summary page

The I/O summary page summarizes all logic pages into a single overview:

- On the left, the input elements of a logic page
- In the middle, the function blocks combined into a block
- On the right, the output elements of a logic page

7.7.10 Simulation mode

In simulation mode, you can test the logic program without the configuration software being connected to the safety controller. Inputs can be set to 1 or 0 and you can observe the subsequent switching of the outputs.

7.7.10.1 Activating simulation mode

Prerequisites

- Valid configuration

Approach

Activating simulation mode

- ▶ Click on the  (**Start simulation mode**) button in the toolbar.
- ✓ The background of the logic editor turns light green and the simulation toolbar is displayed.

Deactivating simulation mode

- ▶ To end simulation mode, click on the  (**Stop simulation mode**) button.
- ✓ The simulation mode is exited and the background of the logic editor changes to gray.

7.7.10.2 Starting the simulation

Overview

You can run the simulation step-by-step or in endless run mode.

Prerequisites

- Activated simulation mode

Approach

Running simulation step-by-step

- ▶ Click on the button with the desired time interval.
- ▶ Or, in the input field to the right of the buttons, enter a user-defined time. The time must be a multiple of the logic execution time. Click on the blue button next to the input field.
- ✓ The simulation jumps forward by the corresponding time interval.
- ▶ The timer can, if necessary, be reset by clicking the blue **Reset simulation** button.

Starting simulation in endless run mode

1. Click on the green **Start continuous run mode** button in the simulation toolbar.
- ✓ The simulation starts.
2. If necessary, slow down the simulation. Move the slide control on the simulation toolbar to the left.
- ✓ The simulation slows down.

Stopping simulation in endless run mode

1. To stop the currently running simulation, click on the red **Stop continuous run mode** button.
- ✓ The simulation stops.
2. The timer can, if necessary, be reset by clicking the blue **Reset simulation** button.

Complementary information

Simulation with the **External device monitoring V1** function block in endless run mode is only possible without errors with the **bypass EDM function** function. The function block then behaves in the simulation as follows:

- Control input input = Enabled output
- EDM feedback signal input is ignored.

7.7.10.3 Setting inputs

Overview

You can set inputs to 1 or 0 during simulation mode. This is also possible before starting the simulation.

Setting the inputs before starting the simulation allows you, for example, to switch multiple inputs at the same time without a discrepancy time.

Approach

1. Click on an inactive input.
 - ✓ The input is set to 1.
2. Click on an active input.
 - ✓ The input is set to 0.

Complementary information

- An active input (1) is displayed in blue before the simulation is started.
- An active input (1) is displayed in green once the simulation is started.
- An inactive input (0) is displayed in white.

7.8 Report main navigation menu

The report summarizes all information about the configuration of the safety controller. You can select or deselect parts of the report. You can also export a parts list as a CSV file.

7.9 Service main navigation menu

Overview

You can run the following under service:

- Reboot device
- Reset the device to factory settings
- Managing passwords

Prerequisites

- Existing connection between the configuration software and device

7.9.1 Assigning or changing passwords

Approach

1. Establish connection to the device.
 2. In the device window under the main navigation **Service**, select the **User password** entry.
 3. In the **User password** dialog, select the user group.
 4. Enter the new password twice and use **Transmit to device** to confirm.
 5. When you are prompted to log on, select your user group and enter the corresponding password.
- ✓ The new password is valid for the user group immediately.

7.9.2 Resetting the password

Overview

If you have forgotten the password of the Admin user group, you can reset it with the assistance of SICK.

Approach

Resetting the password

1. Request the form for resetting your password from SICK support.
2. Connect to the device in Safety Designer.
3. In the device window under the main navigation **Service**, select the **User password** entry.
4. In the **User password** dialog box, select the **Start password reset process** option.
5. Send the information displayed on the form to SICK support.
- ✓ You will then receive an activation code.
6. Enter and confirm the activation code in the field provided.
- ✓ The password of the **Admin** user group is reset to factory settings (SICKSAFE). The **Maintenance** and **Authorized customer** user groups are deactivated. The configuration is not changed.

7.10 Establishing a connection

Overview

To read a configuration from the device or transfer a configuration to the device, it is necessary to establish a connection between the configuration software and the safety controller.

Approach

1. Check whether the safety controller is connected correctly.
2. Click on **Connect** in the toolbar.
- ✓ The configuration software establishes the connection to the safety controller.

Complementary information

When a connection to the safety controller is established, the configuration software changes to online mode. In online mode, the configuration software displays individual statuses (online monitoring) in the logic editor, e.g., of the inputs and outputs.

7.11 Transferring the configuration

Important information



NOTE

When transmitting the configuration, the protective device's existing configuration may be overwritten.

Prerequisites

- Existing connection between the configuration software and device

Approach

1. Use one of the following options to check whether a connection to the correct safety controller exists.

- Click on **Identification** in the toolbar. The LEDs of the main module light up sequentially.
 - Compare the serial number in the configuration software with the type label of the module.
2. Click on **Transfer to device**.
 - ✓ The transfer process is indicated in the configuration software and on the safety controller.
 3. Verify the configuration.

Further topics

- ["Verifying the configuration content and configuration transfer at the same time", page 118](#)

7.12 Verification

Overview

The verification feature is used to confirm that the configuration corresponds to the safety function.

The following verifications are available:

- Verification of the configuration content and the configuration transfer

Important information



WARNING

Ineffectiveness of the protective device due to lack of or incorrect verification

Persons and parts of the body to be protected may not be recognized in case of non-observance.

- ▶ While the configuration content and the configuration transfer have not yet been verified, make sure there are no people in the hazardous area. If necessary, implement additional safety measures.
- ▶ Before transferring the configuration, check whether a connection to the correct safety controller exists.
- ▶ Check the verification report carefully before confirming.
- ▶ If the configuration deviates from the safety function or does not fulfill the requirements in the risk assessment, **do not** confirm the verification.
- ▶ Only operate the safety controller as a protective device if the configuration is verified.

Verification of the configuration content and the configuration transfer

This verification is used to check in one step whether the configuration is correct and whether the correct configuration record has been loaded in the device.

Complementary information

- If you change any safety-related parameters of a verified configuration, then the status is reset to "Not verified".
- A continuously lit yellow CV status indicator on the main module, and the device window of the configuration software indicate the "Verified" status.

Further topics

- ["Checksums", page 118](#)

7.12.1 Verifying the configuration content and configuration transfer at the same time

Prerequisites

- Existing connection between the configuration software and device

Approach

1. Check whether a connection to the correct safety controller exists.
 2. Click on **Verify** in the toolbar.
 3. Check the verification report.
 4. If the configuration content is correct, click on **Confirm**.
- ✓ The configuration content is verified.

Complementary information

- The configuration of connected elements is not part of the safety controller verification. Connected devices must be verified separately where applicable. For information about this, please refer to the operating instructions for the devices in question.

Further topics

- ["Checksums", page 118](#)

7.13 Checksums

Checksums

The configuration software displays various checksums in the report and on the hardware configuration information page.

Each checksum exists both within the configuration project and in the SmartPlug of the respective safety controller. The checksums in the SmartPlug correspond to those checksums in the project that applied when the configuration was last transferred.

Checksums:

- Overall checksum value
The total checksum includes the safety configuration and the standard configuration.
- Safety checksum
The safety checksum includes the safety configuration.
- Standard checksum
The standard checksum includes the standard configuration (configuration data of the non-safety function).
- Verification checksum
This checksum includes the safety configuration at the time of the most recent verification. If this checksum and the verification checksum are identical, the configuration of the safety controller is considered verified.

Complementary information

Each checksum is 4 bytes long.

The configuration data of the safety configuration are part of the verification report and must be confirmed. Other configuration data are information-only components of the report.

Further topics

- ["Offline, online and security configuration", page 45](#)

7.14 Testing safety functions

Overview

You can use this function to test the safety functions of the application.

Prerequisites

The configuration has been transferred to the safety controller.

Approach

1. Click on .
- ✓ The safety controller starts.
2. The safety functions are tested.
3. Click on .
- ✓ The safety controller stops.

Complementary information

If the configuration has not been verified, a manual start of the safety controller using the configuration software is required.

8 Commissioning

8.1 Check during commissioning and modifications

The thorough check is intended to ensure that the safety functions are fulfilling their planned purpose and whether persons are being adequately protected.

- ▶ Carry out the checks specified in the test plan of the manufacturer of the machine and the operating entity.

9 Operation

9.1 Status indicators

Possible indications

Table 125: PWR and CV indications

Display PWR	Display CV	Description	Measures
○	○	No supply voltage	<ul style="list-style-type: none"> ▶ Check terminals A1 and A2. ▶ Switch on the supply voltage to the main module.
○	● Yellow (2 Hz)	The device is being reset to factory settings. The memory of the SmartPlug is being erased.	<ul style="list-style-type: none"> ▶ Do not disconnect from the voltage supply until the device has been reset to factory settings.
● Red / green (1 Hz)	● Yellow (2 Hz)	Configuration is being transferred to the device. Configuration data are being saved in the SmartPlug.	<ul style="list-style-type: none"> ▶ Do not disconnect from the voltage supply until the save process has completed.
● Red / green (1 Hz)	○	Self-test is in progress or the safety controller is being initializing.	
● Green (1 Hz)	see table 126, page 121	Application is ready to run.	<ul style="list-style-type: none"> ▶ Press the start button in the configuration software.
● Red / green (1 Hz)	see table 126, page 121	Application is running. A recoverable external error is present at this module.	<ul style="list-style-type: none"> ▶ Check the cabling of the flashing inputs and outputs.
● Green	see table 126, page 121	Application is running.	
● Red (1 Hz)	● Yellow (lights up every 2 s)	SmartPlug not inserted or incompatible with this module.	<ul style="list-style-type: none"> ▶ Check the version and type of the SmartPlug. ▶ Plug in the SmartPlug.
● Red (1 Hz)	○	Configuration is invalid.	<ul style="list-style-type: none"> ▶ Check the module type and version. ▶ Adjust the configuration using the configuration software. ▶ Run diagnostics using the configuration software.
● Red (2 Hz)	○	Critical error, presumably at this module. The application was stopped. All outputs of the safety controller are switched off.	<ul style="list-style-type: none"> ▶ Switch the supply voltage off and then on again. ▶ If the fault persists, replace the module. ▶ Run diagnostics using the configuration software.
● Red	○	Critical error, presumably at another module. The application was stopped. All outputs of the safety controller are switched off.	<ul style="list-style-type: none"> ▶ Switch the supply voltage off and then on again. ▶ If the fault persists, replace the module where the PWR ● is showing red (2 Hz). ▶ Run diagnostics using the configuration software.

○ LED off. ● LED flashes. ● LED illuminates.

Table 126: CV indications

Display CV	Description	Measures
○	see table 125, page 121	
● Yellow	Configuration is verified.	

Display CV	Description	Measures
● Yellow (1 Hz)	Configuration is not verified.	▶ Verify the configuration using the configuration software.
● Yellow (2 Hz)	see table 125, page 121	
● Yellow (lights up every 2 s)	see table 125, page 121	

○ LED off. ● LED flashes. ● LED illuminates.

Table 127: I indications (safety capable input)

Display I	Description	Measures
○	Input is inactive (LOW).	
● Green	Input is active (HIGH).	
● Green (1 Hz) in sync with the red PWR indication	Input is inactive (LOW) and a recoverable external error is present.	▶ Check cabling of the flashing inputs. A short-circuit to GND or cable break may be present.
● Green (1 Hz) in sync with the green PWR indication	Input is active (HIGH) and a recoverable external error is present.	▶ Check cabling of the flashing inputs. A short-circuit to 24 V or a cross-circuit to another signal may be present.

○ LED off. ● LED flashes. ● LED illuminates.

Table 128: I indications (safety capable input) - Flexi Loop

Display I (Flexi Loop)	Description	Measures
● Green	Flexi Loop safe series connection is in operation.	
● Green (1 Hz) in sync with the red PWR indication	Flexi Loop safe series connection is not in operation and a recoverable external error is present.	<ul style="list-style-type: none"> ▶ Check cabling of the flashing inputs. ▶ Check the number and type of Flexi Loop nodes. ▶ Adjust the configuration using the configuration software. ▶ Run diagnostics using the configuration software.
● Green (1 Hz) in sync with the green PWR indication	Flexi Loop safe series connection is being initialized.	

○ LED off. ● LED flashes. ● LED illuminates.

Table 129: Q indications (safety output)

Display Q	Description	Measures
○	Output is inactive (LOW).	
● Green	Output is active (HIGH).	
● Green (1 Hz) in sync with the red PWR indication	Output is inactive (LOW) and a recoverable external error is present.	<ul style="list-style-type: none"> ▶ Check cabling of the flashing outputs. A short-circuit to GND or a cross-circuit between outputs may be present. ▶ If all indicators of the configured outputs are flashing, check the supply voltage of the A1 and A2 terminals.
● Green (1 Hz) in sync with the green PWR indication	Output is active (HIGH) and a recoverable external error is present.	▶ Check cabling of the flashing outputs. A short-circuit to 24 V or a cross-circuit between outputs may be present.

○ LED off. ● LED flashes. ● LED illuminates.

Table 130: X indications (test output)

Display X	Description	Measures
○	Output is inactive (LOW).	
● Green	Output is active (HIGH).	
● Green (1 × flashing every 2 s)	Output is configured as a test output.	
● Green (2 × flashing every 2 s)	Output is configured as a Flexi Loop data output (DATA_OUT).	

○ LED off. ● LED flashes. ● LED illuminates.

Complementary information

The input and output indicators display the status of the terminals with a refresh rate of approx. 50 ms.

Further topics

- ["Status indicators", page 15](#)

9.2 Regular thorough check

The thorough check is intended to ensure that the safety functions are fulfilling their planned purpose and whether persons are being adequately protected.

- ▶ Carry out the checks specified in the test plan of the manufacturer of the machine and the operating entity.

10 Maintenance

10.1 Regular thorough check

The thorough check is intended to ensure that the safety functions are fulfilling their planned purpose and whether persons are being adequately protected.

- ▶ Carry out the checks specified in the test plan of the manufacturer of the machine and the operating entity.

11 Troubleshooting

11.1 Possible faults

Important information



NOTE

If a fault response can result in an undesired valid status, you should evaluate the associated status bits in the logic to initiate suitable measures.

Possible faults and their causes

Table 131: Faults in the logic

Fault	Responses	Causes
Voltage supply A1 / A2 of the main module is lower than the operating range	<ul style="list-style-type: none"> • Safety controller switches to the No supply voltage status • Voltage supply module status bit = 0 • Status indicators are off 	<ul style="list-style-type: none"> • Fault in the voltage supply • Line break • Interruption due to a fuse
Voltage supply of the main module is higher than the operating range	<ul style="list-style-type: none"> • Safety controller switches to the critical error status • Internal error module status bit = 0 	<ul style="list-style-type: none"> • Fault in the voltage supply • Short-circuit to other voltage-carrying line

Table 132: Faults in the safety capable inputs (I)

Fault	Responses	Causes
Electro-mechanical switch/safety switch (EMSS), safety sensors with test input, Flexi Loop: safety capable input is Low instead of High	<ul style="list-style-type: none"> • Process data bit of the affected input = 0 	<ul style="list-style-type: none"> • Short-circuit to another line e.g., GND • Error in the sensor • Line break
Electro-mechanical switch/safety switch (EMSS), safety sensors with test input, Flexi Loop: test pulses from the associated test output X are not detected correctly (short-circuit detection)	<ul style="list-style-type: none"> • Process data bit of the affected input = 0 • Status Ix process data status bit = 0 • Module status bit of the affected Status Ix input = 0 	<ul style="list-style-type: none"> • Short-circuit to other voltage-carrying line • Error in the sensor (for externally tested sensors)
Dual-channel electro-mechanical safety switch (EMSS), safety sensors with monitored semiconductor outputs (OSSD): equivalent/complementary safety capable inputs exhibit different/the same values.	<ul style="list-style-type: none"> • Process data bit of the affected input = 0 • Status Ix, Iy dual-channel evaluation process data status bit = 0 • Module status bit of the affected Status Ix, Iy dual-channel evaluation input = 0 	<ul style="list-style-type: none"> • Short-circuit to another line e.g., GND • Error in the sensor • Line break • Discrepancy time • Sequence error

Fault	Responses	Causes
Safety pressure mats: safety capable input is Low instead of test pulse signal from the associated test output X	<ul style="list-style-type: none"> Process data bit of the affected input pair = 0 Status Ix process data status bit = 0 Module status bit of the affected Status Ix input = 0 	<ul style="list-style-type: none"> Line break Test output → sensor Line break Sensor → safety capable input
Safety pressure mats: Only one of the two safety inputs is High instead of test pulse signal from the associated test output X	<ul style="list-style-type: none"> Process data bit of the affected input = 0 Status Ix, Iy dual-channel evaluation process data status bit = 0 Module status bit of the affected Status Ix, Iy dual-channel evaluation input = 0 	<ul style="list-style-type: none"> Short-circuit to other voltage-carrying line
Internal error detected in input evaluation	<ul style="list-style-type: none"> Safety controller switches to the critical error status Internal error module status bit = 0 	<ul style="list-style-type: none"> Internal device error

Table 133: Faults in the safety outputs (Q)

Fault	Responses	Causes
Output voltage level is Low instead of High when the output is “On”, overload/overcurrent ^{1) 2)}	<ul style="list-style-type: none"> Associated output/associated output pair is switched off Depending on the load, the affected output may pulsate temporarily until the final switch-off Status Qx short-circuit to Low process data status bit = 0 Status Qx short-circuit to Low module status bit = 0 	<ul style="list-style-type: none"> Short-circuit or resistance drop under load Short-circuit to another line e.g., GND
Output voltage level is High instead of Low when the output is “Off” ³⁾	<ul style="list-style-type: none"> All safety outputs of the module are switched off Output voltage supply process data status bit = 0⁴⁾ 	<ul style="list-style-type: none"> Short-circuit to other voltage-carrying line
Test pulses are not detected correctly when the output is “On” ^{3) 5)}	<ul style="list-style-type: none"> Status Qx short-circuit to High process data status bit = 0 Status Qx short-circuit to High module status bit = 0 	<ul style="list-style-type: none"> Short-circuit to other voltage-carrying line Capacitive load too high
Internal error detected	<ul style="list-style-type: none"> Safety controller switches to the critical error status Internal error module status bit = 0 	<ul style="list-style-type: none"> Internal device error Capacitive load too high

- 1) Depending on the voltage supply used, an overcurrent can also result in the voltage supply dropping out.
- 2) Reset of the error: set the process data bit of the safety output to 0.
- 3) Reset of the error: the process data bits for all safety outputs of the module are simultaneously 0 and the output level is Low.
- 4) In the case of a High instead of a Low on a safety output, the supply to all safety outputs is switched off internally. If the cause of a short-circuit is in the wiring to 24 V, then the affected signal remains High and all other signals switch to Low.
Check if this is an undesired but valid signal value for the receiver, e.g., for the switching of the monitoring case of a SICK safety laser scanner by means of a complementary signal.
- 5) Depending on the size of the capacitive load, this may lead in certain cases to an incorrect interpretation as an internal error since the effect on the output voltage is only temporary.

Table 134: Faults in the test outputs (X)

Fault	Responses	Causes
Voltage supply A1 / A2 for the test outputs is lower or higher than the operating range	See voltage supply A1 / A2 of the main module. The test outputs are supplied from the voltage supply of the main module.	

Fault	Responses	Causes
Output voltage level is Low instead of High when "On", overload/overcurrent ¹⁾	<ul style="list-style-type: none"> Associated output/associated output pair are switched off temporarily (thermal overload limiting). No status indicator or diagnostic message available for this fault. 	<ul style="list-style-type: none"> Short-circuit or resistance drop under load Short-circuit to another line e.g., GND
Output voltage level is High instead of Low when "Off"	<ul style="list-style-type: none"> No status indicator or diagnostic message available for this fault. 	<ul style="list-style-type: none"> Short-circuit to other voltage-carrying line

¹⁾ Depending on the voltage supply used, an overcurrent can also result in the voltage supply dropping out.

Critical error status

Consequences of the critical error status:

- All applications are stopped.
- All safety outputs are switched off.
- All process data = 0
- Evaluation of the process data status bits in the logic is no longer possible.
- Only limited diagnostics can be performed in the critical error status.

Alternatives to resetting the critical error status:

- Restart by switching the voltage supply off and on again
- Software reset using the configuration software

Complementary information

The status indicators and diagnostic messages may provide additional information.

Further topics

- ["Status indicators", page 121](#)
- ["Input elements", page 49](#)
- ["Diagnostics using Safety Designer", page 127](#)

11.2 Diagnostics using Safety Designer

Prerequisites

- The safety controller must be connected to Safety Designer.

Diagnostics area

The main navigation menu has a **Diagnostics** area. This area contains the following functions:

- Diagnostic bits** : Displays all messages, information, warnings, and error messages of the safety controller.

11.2.1 Error history

Error history

Table 135: Error history information

Keyword	Description
Type	Error type (e.g., information, warning, recoverable error, serious error)
Occurrence	Operating time between when the main module was last switched on and when the error occurred (power-on cycles of the main module/days:hours:minutes:seconds)
Local time of occurrence	Time when the error occurred (system time of the computer). This value is not displayed for historical errors.

Keyword	Description
Site	Module position and type code of the module that detected the error
Error code	Hexadecimal error code
Support info	Internal information about the error
Message	Description of the fault that occurred
Acknowledged	The error has been marked as viewed
Reason	Detailed information on the cause of the error
Solution	Suggested solution for eliminating the error

Complementary information

Clicking an entry in the list selects that entry and displays the details of the selected message.

The diagnostic messages are also included in the report. You can use the report to save or print out the diagnostic messages.

Further topics

- ["Report main navigation menu", page 115](#)

12 Decommissioning

12.1 Disposal

Approach

- ▶ Always dispose of unusable devices in accordance with national waste disposal regulations.



Complementary information

SICK will be glad to help you dispose of these devices on request.

13 Technical data

13.1 Data sheet

Safety-related parameters

Table 136: Safety-related characteristic data - safety capable inputs (I)

	Safety capable inputs (I)			
	Single-channel		Dual channel	
	Without test pulses ¹⁾	With test pulses	Without test pulses ²⁾	With test pulses
Safety integrity level (IEC 61508)	SIL 2	SIL 3	SIL 3	SIL 3
SIL claim limit (IEC 62061)	SILCL 2	SILCL 3	SILCL 3	SILCL 3
Category (ISO 13849-1)	Category 3	Category 4	Category 4	Category 4
Performance level (ISO 13849-1)	PL d	PL e	PL e	PL e
PFH _D (h ⁻¹)	1 × 10 ⁻⁹	1 × 10 ⁻⁹	0.5 × 10 ⁻⁹	0.5 × 10 ⁻⁹
PFD _{avg}	4 × 10 ⁻⁵	4 × 10 ⁻⁵	4 × 10 ⁻⁵	4 × 10 ⁻⁵
MTTF _D (ISO 13849-1) [years]	500	500	500	500
T _M (ISO 13849-1) [years]	20	20	20	20

¹⁾ If you are using single-channel safety inputs (I) without test pulses for a safety-related application, then a protected or separate cabling is required for these safety inputs in order to achieve the safety-related characteristics. Reason: Short-circuits to the supply voltage or cross-circuits are not detected.

²⁾ If you are using dual-channel safety capable inputs (I) without test pulses, the safety function must be requested at least once a year.

Table 137: Safety-related characteristic data - CPU logic processing

	CPU logic processing
Safety integrity level (IEC 61508)	SIL 3
SIL claim limit (IEC 62061)	SILCL 3
Category (ISO 13849-1)	Category 4
Performance level (ISO 13849-1)	PL e
PFH _D (h ⁻¹)	3 × 10 ⁻⁹
PFD _{avg}	20 × 10 ⁻⁵
MTTF _D ISO 13849-1 [years]	500
T _M ISO 13849-1 [years]	20

Table 138: Safety-related characteristic data - safety outputs (Q)

	Safety outputs (Q)			
	Single-channel ¹⁾		Dual channel	
	Without test pulses ^{2) 3)}	With test pulses	Without test pulses ^{2) 3)}	With test pulses
Safety integrity level (IEC 61508)	SIL 3	SIL 3	SIL 3	SIL 3
SIL claim limit (IEC 62061)	SILCL 3	SILCL 3	SILCL 3	SILCL 3
Category (ISO 13849-1)				
With test pulses on all safety outputs of a module		Category 4		Category 4
Without test pulses on one or more safety outputs of a module	Category 3	Category 3	Category 4	Category 4
Performance level (ISO 13849-1)	PL e	PL e	PL e	PL e
PFH _D (h ⁻¹)	5 × 10 ⁻⁹	0.5 × 10 ⁻⁹	5 × 10 ⁻⁹	0.5 × 10 ⁻⁹
PFD _{avg}	30 × 10 ⁻⁵	4 × 10 ⁻⁵	30 × 10 ⁻⁵	4 × 10 ⁻⁵
MTTF _D ISO 13849-1 [years]	500	500	500	500
T _M ISO 13849-1 [years]	20	20	20	20

- 1) If you are using single-channel safety outputs (Q) for a safety-related application, then a protected or separate cabling is required for these safety outputs in order to achieve the safety-related characteristics. Reason: While short-circuits to the supply voltage or cross-circuits to other outputs can be detected, no other option to switch-off the device exist.
- 2) If you are using single-channel or dual-channel safety outputs (Q) without test pulses, then a protected or separate cabling is required for these safety outputs in order to achieve the safety-related characteristics. Reason: Short-circuits to the supply voltage or cross-circuits to other outputs are not detected in the switched-on state without test pulses.
This also applies if an output is used for a non-safety related application. Reason: Even if an internal hardware error is detected, the switch-off capability of the other safety outputs may be impaired by reverse currents.
- 3) If you are using single-channel/dual-channel safety outputs (Q) without test pulses for a safety-related application, then one of the following measures is required in order to achieve the safety-related characteristics:
 - Restart the safety controller once a year.
 - Manually switch off all safety outputs simultaneously for min. 2 s once a year. The supply voltage to the outputs must be within the operating range during this manual test.

General data

Table 139: General data

Climatic conditions	
Ambient operating temperature	
At altitudes up to 2,000 m above sea level	-25 °C ... +55 °C

At altitudes up to 2,000 m above sea level ... 3,000 m above sea level	-25 °C ... +50 °C
At altitudes 3,000 m above sea level ... 4,000 m above sea level	-25 °C ... +45 °C
Storage temperature	-25 °C ... +70 °C
Air humidity	10% ... 95%, non-condensing
Operating altitude	Max. 4,000 m above sea level
Mechanical strength	
Vibration resistance	5 Hz ... 200 Hz / 1 g (EN 60068-2-6)
Shock resistance, single shock	15 g, 11 ms (EN 60068-2-27)
Operating data	
Protection class	III (EN 61140)
Immunity to interference	EN 61000-6-2
Emitted interference	EN 61000-6-4
Connections	
Connection type	Spring terminals CPUc2: RJ45 female connector
Wire cross-section	Single wire or fine-stranded wire: 0.14 mm ² ... 1.5 mm ² Fine-stranded wire with ferrule: a) with plastic ferrule max. 1.0 mm ² b) without plastic ferrule max. 1.0 mm ² AWG according to UL/CSA: 26 ... 14 For UL and CSA applications: Use copper conductors only min. rated for 85 °C.
Network cable requirements	<ul style="list-style-type: none"> • Type: 100Base-TX • Cables with RJ45 connections • Twisted pair Ethernet cable, maximum length 100 m in accordance with EN 50173 • Use of wire pairs 1/2 and 3/6 • Shielded cables • Cat 5 STP or higher
Housing	
Enclosure rating	IP20 (EN 60529) ¹⁾
Contamination rating	2 (IEC 61010-1)
Control device type	Open device (IEC 61010-2-201)
Weight (± 5%)	CPUc1: 277 g CPUc2: 282 g

¹⁾ Prerequisite: The front plug is mounted.

Voltage supply (A1 / A2)

Table 140: Voltage supply

Supply voltage U _B	+24 V DC
Tolerance of supply voltage	-30% / +25% (16.8 V ... 30 V)
Type of supply voltage	PELV or SELV The supply current must be limited externally to max. 8 A – either by the voltage supply unit used, or by means of a fuse.
Max. power loss	CPUc1: 6.2 W CPUc2: 6.3 W

Current consumption at nominal voltage (without outputs)	125 mA
Short-circuit protection ¹⁾	Max. 8 A/Min. 30 V Safety fuse with triggering characteristic: slow-blow UL/CSA applications: UL-listed fuse according to UL 248-14 required
Overvoltage category	II (EN 61131-2)
Power-up delay	15 s
Type of terminal connections	Spring terminals

- ¹⁾ Take into account the following when designing the voltage supply for the safety controller:
- Current consumption at nominal voltage (without outputs) of all station modules
 - Peak current consumption of all electric consumers connected via the safety controller outputs
- The maximum permissible supply current depends, amongst other things, on the ambient temperature and must not exceed the permitted value of 8 A ($T_a = 55\text{ °C}$). Take into consideration the effect of lack of ventilation or the power loss in cables or other devices on the ambient temperature in the control cabinet.

Safety capable inputs (I)

Table 141: Technical data for the safety capable inputs (I)

Input voltage High	11 V DC ... 30 V DC
Input voltage Low	-3 V DC ... +5 V DC
Max. input voltage range ¹⁾	-60 V DC ... +60 V DC
Input current high	2.1 mA ... 6 mA
Input current Low	≤ 1.9 mA
Reverse current at input in case of loss of ground connection ²⁾	≤ 100 µA
Input capacitance	15 nF
Discrepancy time	4 ms ... 30 s, configurable
Input elements Safety sensors with monitored semiconductor output (OSSD)	
Test pulse width	Max. 1 ms
Test pulse interval	Min. 1,5 ms

- ¹⁾ No damage to the input in this voltage range.
²⁾ Do not connect any other safety capable inputs in parallel if the reverse current could lead to a High state on the other input.

Test outputs (X) used with safety capable inputs

Table 142: Technical data for the test outputs (X) when used with safety capable inputs

Type of output	Push-pull semiconductor, short-circuit protected, cross-circuit monitored
Output voltage High	$U_B - 3\text{ V DC} \dots U_B$
Max. output voltage Low ¹⁾	-50 V DC ... -30 V DC
Output current High	≤ 100 mA
Leakage current Low	≤ 0.1 mA
Output resistance Low ²⁾	≤ 25 Ω
Test pulse width	2 ms ... 100 ms, configurable
Test pulse interval	8 ms ... 1,000 ms, configurable
Load capacity	
@ 2 ms test pulse width	≤ 0.5 µF

@ 4 ms test pulse width	≤ 1 μF
Inductive load at nominal voltage @ 100 mA	1,000 mH

- 1) Max. -30 V DC, to avoid damaging the output.
Max. -50 V DC, for fast switch-off of inductive loads.
- 2) The output current is actively limited.

Test outputs (X) used as non-safe outputs

Table 143: Technical data when using test outputs (X) as non-safe outputs (PNP or NPN)

Type of output	Push-pull semiconductor, short-circuit protected
Output voltage High	$U_B - 3 \text{ V DC} \dots U_B$
Max. output voltage Low ¹⁾	-50 V DC ... -30 V DC
Maximum output current when used as a PNP output	100 mA
Maximum output current when used as a NPN output	-15 mA
Leakage current Low	≤ 0.1 mA
Inductive load at nominal voltage ²⁾ @ 100 mA	1,000 mH
Load capacity	1,000 μF

- 1) Max. -30 V DC, to avoid damaging the output.
Max. -50 V DC, for fast switch-off of inductive loads.
- 2) Only permissible if used as a PNP output.

Safety outputs (Q)

Table 144: Technical data for the safety outputs (Q)

Type of output	PNP semiconductor, short-circuit protected
Output voltage High	$U_B - 3 \text{ V DC} \dots U_B$
Max. output voltage Low ¹⁾	-50 V DC ... -30 V DC
Maximum reverse voltage at Low ²⁾	3 V DC
Leakage current Low	
Normal operation	< 1 mA
Dual channel	< 2 mA
Fault ³⁾	< 1 mA
Output current	Max. 2 A
Sum current I_{sum}	
$T_U \leq 55 \text{ °C}$	4 A
Test pulse width ⁴⁾	< 650 μs or deactivated
Test pulse interval	≥ 190 ms
Cross-circuit detection using test pulses ⁵⁾	
Cable resistance	Max. 2.5 Ω (z. B. 100 m × 1.5 mm ² = 1.2 Ω)
Output current, dual-channel outputs	Max. 1 A per output
Load capacity	≤ 0.5 μF
Load capacity when connected via diode	≤ 1,000 μF
Inductive load at nominal voltage	
@ 2 A	100 mH

@1 A	1.6 H
@0.5 A	20 H

- 1) Max. -30 V DC, to avoid damaging the output.
Max. -50 V DC, for fast switch-off of inductive loads.
- 2) Higher voltages are evaluated as a cross-circuit fault
- 3) In the event of a fault (GND line open circuit) and with a load resistance of at least 2.5 kΩ, no more than the specified leakage current flows on the safety output. For lower load resistances, the leakage current may be greater however the output voltage will be < 5 V in this case. A downstream device, for example a relay or a FPLC (fail-safe programmable logic controller) must detect this state as Low.
- 4) When activated, the outputs are tested regularly (brief switching to Low). When selecting the downstream control elements, ensure that the test pulses with the specified parameters do not result in a switch-off, or deactivate the test pulses on the outputs yourself.
- 5) Safety outputs (Q) with test pulses only detect cross-circuits reliably (i.e. already in the switched-on state and not just after a switch-off) if these values for the supply cable and the connected control element are not exceeded. Otherwise further measures will be required, for example protected or separate cabling. (See also EN 60204 Electrical equipment of machines, Part 1: General requirements.)

Network interface of the main module

Table 145: Network interface of the main module

Interface	Modbus® TCP SLMP
Connection type	1 × RJ45 female connector
Transfer rate	10 Mbit/s (10 Base-T) or 100 Mbit/s (100 Base-TX), autosensing
Default settings for addressing	IP address: 0.0.0.0 Subnet mask: 0.0.0.0 Default gateway: 0.0.0.0 DHCP: enabled
MAC address	Printed on the type label, e.g.: 00:06:77:02:00:A7

13.2 Maximum response time

Safety controller response times

The response time of a function depends on the hardware and software configuration of the safety controller. You need to take all factors into account when calculating the response time and consider all signal paths separately.

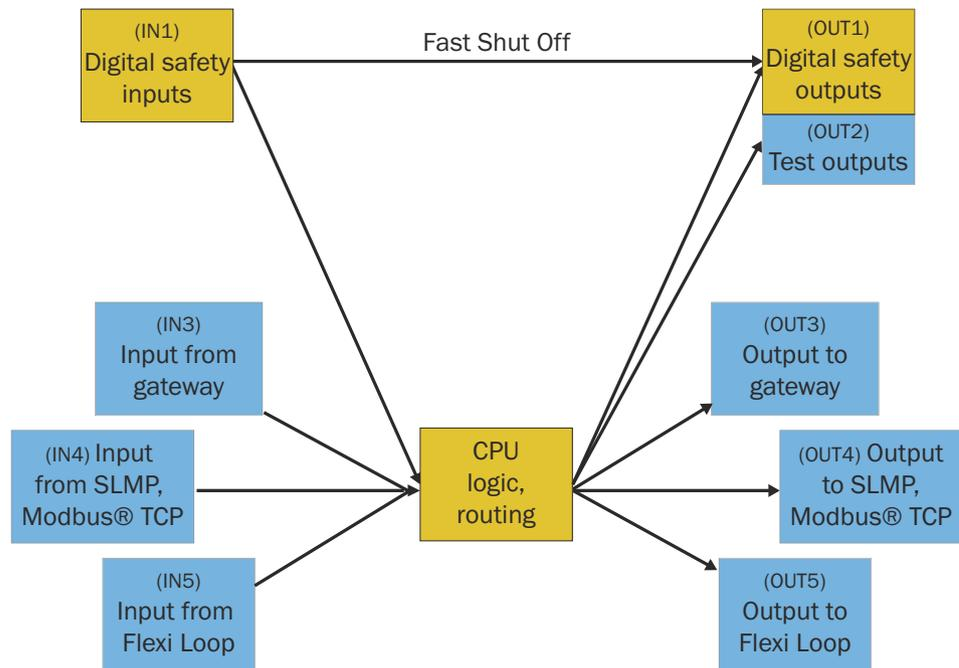

Figure 53: Safety controller response times

Complementary information

The Fast Shut Off function only has an effect on the inputs and outputs of the same module. Response times of 4.5 ms can be achieved using fast shut off.

13.2.1 Calculating the response time

Overview

You need to consider each signal path separately when calculating the response time.

Important information



NOTE

The calculation applies exclusively to the safety controller. You need to separately consider the response times of sensors and actuators.

Approach

- ▶ Use the following table to calculate the response time of the connected signal paths of the safety controller.

Table 146: Calculating the maximum response time

Components of the calculation	Description	Value [ms]
1. Inputs	Response time of the observed input in the signal path	IN1, IN3, IN4 or IN5 <ul style="list-style-type: none"> • "IN1 - Response time of safety inputs (!)", page 137 • "IN3 ... IN5 - Response time for processing of incoming process data", page 137

Components of the calculation	Description	Value [ms]	
2. Logic	a) Response time of the main module logic	<p>2 × logic execution time Take the value from the report in the configuration software.</p> <p>Delay time due to logic application (e.g. switch-on delay or switch-off delay function block) Take the value from the report in the configuration software.</p>	
	b) Response time of the routing	For OUT3 output to the gateway only Delay time: 8 ms	
	c) Response time of the fast shut off logic	No delay time	0
3. Outputs	Response time of the observed output in the signal path	<p>OUT1, OUT2, OUT3, OUT4 or OUT5</p> <ul style="list-style-type: none"> • "OUT1 - Response time of safety outputs (Q)", page 138 • "OUT2 - Response time of test outputs (X)", page 138 • "OUT3 ... OUT5 - Response time for processing of outgoing process data", page 138 	
Total			

IN1 - Response time of safety inputs (I)

Table 147: IN1 - Response time of safety inputs (I)

When relevant?	Description	Value [ms]
Always	Input processing time	3
ON-OFF debounce filter is configured.	Min. debounce filter time Take the value from the report in the configuration software.	
Input element is connected to a test output (X).	Max. tolerated test pulse delay Take the value from the report in the configuration software.	
Input element is connected to a test output (X).	<ul style="list-style-type: none"> • For safety sensors with a test input or Flexi Loop: Test pulse interval of the test output • For safety pressure mats: Longer test pulse interval of the two test outputs • For electro-mechanical switch/safety switch (EMSS): Test pulse width of the test output 	
Total		

IN3 ... IN5 - Response time for processing of incoming process data

Table 148: IN3 ... IN5 - Response time for processing of incoming process data

When relevant?	Description	Value [ms]
IN3	When using a gateway.	2 × internal update interval (4 ms) - 2 ms = 6 ms
IN4	When using Modbus® TCP or SLMP.	2 × internal update interval (20 ms) - 2 ms = 38 ms

When relevant?		Description	Value [ms]
IN5	When using Flexi Loop on the expansion module (diagnostic data).	2 × internal update interval (56 ms) - 4 ms = 108 ms	
Total			

OUT1 - Response time of safety outputs (Q)

Table 149: OUT1 - Response time of safety outputs (Q)

When relevant?		Description	Value [ms]
When using single-channel safety output Q.		Potential switch-off delay in the event of a fault ¹⁾ : <ul style="list-style-type: none"> Without the Increased capacitive loads allowed option: 5 ms With the Increased capacitive loads allowed option: 50 ms 	
When using dual-channel safety output Q.		For one or both safety outputs: <ul style="list-style-type: none"> 1 ms A potential switch-off delay in the event of a fault applies to the second safety output ¹⁾ : <ul style="list-style-type: none"> Without the Increased capacitive loads allowed option: 5 ms With the Increased capacitive loads allowed option: 50 ms 	
Fast shut off is used.		0.5 ms	
Total			

¹⁾ If switch-off occurs, a single safety output (Q) may be switched on rather than switched off for this time in the event of an internal hardware error. An undesired switch-on can also occur in the switched off state and is limited to 5 ms by a fault switch-off. Ensure, in particular for single-channel safety outputs, that the resultant pulse does not result in a safety-critical state of the system.

OUT2 - Response time of test outputs (X)

Table 150: OUT2 - Response time of test outputs (X)

When relevant?		Description	Value [ms]
Always		1 ms	
Total			

OUT3 ... OUT5 - Response time for processing of outgoing process data

Table 151: OUT3 ... OUT5 - Response time for processing of outgoing process data

When relevant?		Description	Value [ms]
OUT3	When using a gateway.	2 × internal update interval (4 ms) - 3 ms = 5 ms	
OUT4	When using Modbus® TCP or SLMP.	2 × internal update interval (20 ms) - 3 ms = 37 ms	
OUT5	When using Flexi Loop on the expansion module (service data).	2 × internal update interval (56 ms) - 1 ms = 111 ms	
Total			

Further topics

- ["Report main navigation menu", page 115](#)
- ["Input elements", page 49](#)
- ["Configuration options for input elements", page 49](#)

13.2.2 Example response time calculation

Overview

The example calculation includes 2 signal paths. Each signal path needs to be considered separately in the calculation.

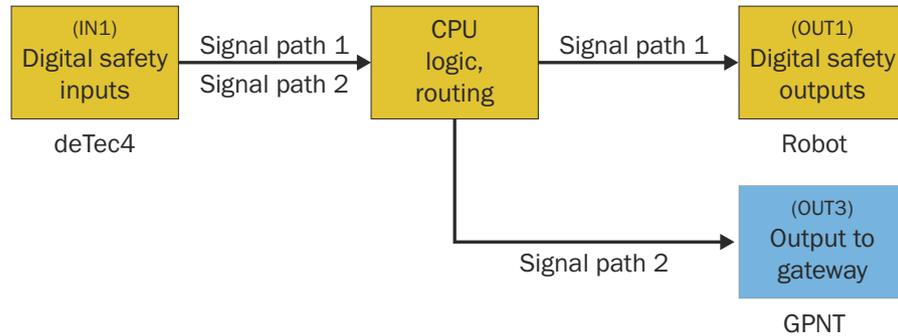

Response time of signal path 1

Table 152: IN1 – Response time of safety capable inputs (I)

When relevant?	Description	Value [ms]
Always	Input processing time	3
ON-OFF debounce filter is configured.	Min. debounce filter time Take the value from the report in the configuration software.	-
Input element is connected to a test output (X).	Max. tolerated test pulse delay Take the value from the report in the configuration software.	-
Input element is connected to a test output (X).	<ul style="list-style-type: none"> • For safety sensors with a test input or Flexi Loop: Test pulse interval of the test output • For safety pressure mats: Longer test pulse interval of the two test outputs • For electro-mechanical switch/safety switch (EMSS): Test pulse width of the test output 	-
Total		3

Table 153: OUT1 – Response time of safety outputs (Q)

When relevant?	Description	Value [ms]
When using single-channel safety output Q.	Potential switch-off delay in the event of a fault ¹⁾ : <ul style="list-style-type: none"> • Without the Increased capacitive loads allowed option: 5 ms • With the Increased capacitive loads allowed option: 50 ms 	-

When relevant?	Description	Value [ms]
When using dual-channel safety output Q.	For one or both safety outputs: <ul style="list-style-type: none"> • 1 ms A potential switch-off delay in the event of a fault applies to the second safety output ¹⁾ : <ul style="list-style-type: none"> • Without the Increased capacitive loads allowed option: 5 ms • With the Increased capacitive loads allowed option: 50 ms 	1
Fast shut off is used.	0.5 ms	-
Total		1

¹⁾ If switch-off occurs, a single safety output (Q) may be switched on rather than switched off for this time in the event of an internal hardware error. An undesired switch-on can also occur in the switched off state and is limited to 5 ms by a fault switch-off. Ensure, in particular for single-channel safety outputs, that the resultant pulse does not result in a safety-critical state of the system.

Table 154: Calculating the maximum response time – signal path 1

Components of the calculation	Description	Value [ms]
1. Inputs	Response time of the observed input in the signal path IN1, IN3, IN4 or IN5 <ul style="list-style-type: none"> • see table 152, page 139 	3
2. Logic	a) Response time of the main module logic 2 × logic execution time Take the value from the report in the configuration software. Delay due to logic application (e.g. switch-on delay or switch-off delay function block) Take the value from the report in the configuration software.	8
	b) Response time of the routing For OUT3 output to the gateway only No delay time	0
	c) Response time of the fast shut off logic No delay time	0
3. Outputs	Response time of the observed output in the signal path OUT1, OUT2, OUT3, OUT4 or OUT5 <ul style="list-style-type: none"> • see table 153, page 139 	1
Total		12

Response time of signal path 2

Table 155: IN1 – Response time of safety capable inputs (I)

When relevant?	Description	Value [ms]
Always	Input processing time	3
ON-OFF debounce filter is configured.	Min. debounce filter time Take the value from the report in the configuration software.	-
Input element is connected to a test output (X).	Max. tolerated test pulse delay Take the value from the report in the configuration software.	-

When relevant?	Description	Value [ms]
Input element is connected to a test output (X).	<ul style="list-style-type: none"> For safety sensors with a test input or Flexi Loop: Test pulse interval of the test output For safety pressure mats: Longer test pulse interval of the two test outputs For electro-mechanical switch/safety switch (EMSS): Test pulse width of the test output 	-
Total		3

Table 156: OUT3 ... OUT5 - Response time for processing of outgoing process data

When relevant?	Description	Value [ms]
OUT3	When using a gateway. 2 × internal update interval (4 ms) - 3 ms = 5 ms	5
OUT4	When using Modbus® TCP or SLMP. 2 × internal update interval (20 ms) - 3 ms = 37 ms	-
OUT5	When using Flexi Loop on the expansion module (service data). 2 × internal update interval (56 ms) - 1 ms = 111 ms	-
Total		5

Table 157: Calculating the maximum response time – signal path 2

Components of the calculation	Description	Value [ms]
1. Inputs	Response time of the observed input in the signal path IN1, IN3, IN4 or IN5 <ul style="list-style-type: none"> see table 155, page 140 	3
2. Logic	a) Response time of the main module logic 2 × logic execution time Take the value from the report in the configuration software. Delay due to logic application (e.g. switch-on delay or switch-off delay function block) Take the value from the report in the configuration software.	8
	b) Response time of the routing For OUT3 output to the gateway only No delay time	0
	c) Response time of the fast shut off logic No delay time	0
3. Outputs	Response time of the observed output in the signal path OUT1, OUT2, OUT3, OUT4 or OUT5 <ul style="list-style-type: none"> see table 156, page 141 	5
Total		16

Further topics

- ["Report main navigation menu", page 115](#)
- ["Input elements", page 49](#)

13.3 Data exchange in the network

13.3.1 Modbus® TCP

Overview

The safety controller supports a Modbus® TCP server without a safety protocol.

Important information



NOTE

- The safety controller supports only the querying and writing of whole memory blocks. Individual items of information must be extracted from the overall information.
- The PDUs (Protocol Data Units) are limited to 256 bytes (252 bytes of user data). Large information fields, for example the safety controller configuration, are therefore spread across multiple messages.
- Modbus® TCP transmits the data in big endian format. The data is organized into 16-bit words and can only be addressed as words.
- The main module processes data internally in little endian format. The sequence of bytes may need to be adjusted when assigning the process data on a byte-wise basis.

Supported commands

- 03 (0x03) Read holding registers
- 04 (0x04) Read input registers
- 06 (0x06) Write single holding register (for address 356 only: Find Me function can be used)
- 16 (0x10) Write multiple holding registers

Memory spaces

The safety controller provides a memory space with input registers and internal registers as an interface to external Modbus® TCP controllers.

Structure of the readable input register (Modbus® TCP input register):

- Memory space from 0 – Device Identify Information
- Memory space from 256 – Results
- Memory space from 2,000 – Status

Structure of the readable and writable register (Modbus® TCP holding register):

- Memory space from 256 – Commands

13.3.1.1 Modbus® TCP input register

13.3.1.1.1 Device

Table 158: Modbus® TCP – Device identification

Address	Contents	Data type	Size	Description
0	Manufacturer name	STRING	4 words (8 bytes)	SICK AG
(4)	Product code	STRING	4 words (8 bytes)	SICK part number
(8)	MajorMinorRevision	STRING	6 words (12 bytes)	Firmware version
(14)	Manufacturer URL	STRING	6 words (12 bytes)	www.sick.com

Address	Contents	Data type	Size	Description
(20)	Product name	STRING	16 words (32 bytes)	Product name, e.g., Flexi Compact CPUc2
(36)	Model name	STRING	9 words (18 bytes)	Type code
(45)	Serial number	STRING	4 words (8 bytes)	Serial number of the module
(49)	Application name	STRING	16 words (32 bytes)	Application name entered in the configuration software
(65)	Modbus® TCP profile version	STRING	6 words (12 bytes)	Version, e.g., 1.0.0

13.3.1.1.2

Result

Table 159: Modbus® TCP – Input data

Address	Contents	Size	Description
256	Input values	1 word (2 bytes)	Is determined by the configuration in the configuration software.
...		1 word (2 bytes)	
280		1 word (2 bytes)	

13.3.1.1.3

Status

Table 160: Modbus® TCP – Checksums, status information and metadata

Address	Contents	Data type	Size
2000	Device status see table 161, page 144	UINT	1 word (2 bytes, MSB always 0)
2001	Required user action see table 162, page 144	UINT	1 word (2 bytes)
2002	Overall checksum value	UINT	2 words (4 bytes)
2004	Safety checksum	UINT	2 words (4 bytes)
2006	Standard checksum	UINT	2 words (4 bytes)
2008	Reserved	UINT	2 words (4 bytes)
2010	Verification checksum	UINT	2 words (4 bytes)
2020	Product codes 1 x CPU 1 x SmartPlug 16 x expansion modules see table 163, page 144	UINT	36 words (72 bytes)
2300 ¹⁾	Module status 4 x CPU status info see table 164, page 145 16 x module status info see table 165, page 145 see table 166, page 146 see table 167, page 146	BYTE	80 words (160 bytes)
3000	Device name	STRING	32 words (64 bytes)
3032	Project name	STRING	32 words (64 bytes)
3064	Application name	STRING	32 words (64 bytes)
3096	User name (optional)	STRING	32 words (64 bytes)

Address	Contents	Data type	Size
3128	Description	STRING	50 words (100 bytes)

- ¹⁾ The first 32 bytes contain the module statuses of the CPU. This is followed by 8 bytes each for the module statuses of the expansion modules. The order depends on the hardware configuration. The content depends on the type of expansion module.

Description of the device status

Table 161: Device status

Value	Device status	Description
0	Unknown State	No supply voltage
1	Start-up	Self-test is in progress or the safety controller is being initializing.
2	Service Mode	Configuration is being transferred to the device. Configuration data are being saved in the SmartPlug.
3	Normal Operation	Application is running.
4	Suspended Operation	Application is ready to run.
6	Service Required	<ul style="list-style-type: none"> SmartPlug not inserted or incompatible with this module. Configuration is invalid.
7	Recoverable Error	Application is running. A recoverable external error is present at this module.
8	Fatal error	The application was stopped. All outputs of the safety controller are switched off.

Description of the required user actions

Table 162: Required user action

Bit	Required user action
0x00 01	Confirm configuration
0x00 02	Check configuration
0x00 08	Check application interface
0x00 10	Checking the device
0x00 20	Perform set-up procedure
0x00 40	Checking the firmware
0x00 80	Waiting

Description of the product codes

Product codes are 4-byte coded device type codes.

Table 163: Product codes

Product codes	Description
0x30 01 00 00	CPUc1 main module
0x31 01 00 00	CPUc2 main module
0x00 05 00 00	EtherCAT gateway expansion module
0x00 06 00 00	PROFINET gateway expansion module
0x00 07 00 00	CANopen gateway expansion module
0x30 0B 00 00	XTDI IO expansion module
0x30 0C 00 00	XTDO IO expansion module
0x30 FF 00 00	SmartPlug

Module status bits for main module

Table 164: Module status bits for main module

	Bit 7	Bit 6	Bit 5	Bit 4	Bit 3	Bit 2	Bit 1	Bit 0
Byte 0	Reserved		Voltage supply	Configuration is valid	Reserved	External error	Internal error	operational status 1 = Run 0 = Other
Byte 1 ... 3	Reserved							
Byte 4	User-defined status bit 7 (CPU logic)	User-defined status bit 6 (CPU logic)	User-defined status bit 5 (CPU logic)	User-defined status bit 4 (CPU logic)	User-defined status bit 3 (CPU logic)	User-defined status bit 2 (CPU logic)	User-defined status bit 1 (CPU logic)	User-defined status bit 0 (CPU logic)
Byte 5	User-defined status bit 15 (CPU logic)	User-defined status bit 14 (CPU logic)	User-defined status bit 13 (CPU logic)	User-defined status bit 12 (CPU logic)	User-defined status bit 11 (CPU logic)	User-defined status bit 10 (CPU logic)	User-defined status bit 9 (CPU logic)	User-defined status bit 8 (CPU logic)
Byte 6 ... 7	Reserved							
Byte 8	Reserved	Fast shut off status (all grouped)	Reserved					
Byte 9	Reserved				Status I7, I8 Dual-channel evaluation	Status I5, I6 Dual-channel evaluation	Status I3, I4 Dual-channel evaluation	Status I1, I2 Dual-channel evaluation
Byte 10	Status I8	Status I7	Status I6	Status I5	Status I4	Status I3	Status I2	Status I1
Byte 11	Status Q4 Short-circuit to Low	Status Q4 Short-circuit to High	Status Q3 Short-circuit to Low	Status Q3 Short-circuit to High	Status Q2 Short-circuit to Low	Status Q2 Short-circuit to High	Status Q1 Short-circuit to Low	Status Q1 Short-circuit to High
Byte 12 ... 16	Reserved							
Byte 17	Reserved				Status I15, I16 Dual-channel evaluation	Status I13, I14 Dual-channel evaluation	Status I11, I12 Dual-channel evaluation	Status I9, I10 Dual-channel evaluation
Byte 18	Status I16	Status I15	Status I14	Status I13	Status I12	Status I11	Status I10	Status I9
Byte 19 ... 24	Reserved							
Byte 25	Reserved						Status I19, I20 Dual-channel evaluation	Status I17, I18 Dual-channel evaluation
Byte 26	Reserved				Status I20	Status I19	Status I18	Status I17
Byte 27 ... 31	Reserved							

Module status bits for XTDI

Table 165: Module status bits for XTDI

	Bit 7	Bit 6	Bit 5	Bit 4	Bit 3	Bit 2	Bit 1	Bit 0
Byte 0	Reserved					External error	Reserved	

	Bit 7	Bit 6	Bit 5	Bit 4	Bit 3	Bit 2	Bit 1	Bit 0
Byte 1	Reserved				Status 17, 18 Dual-channel evaluation	Status 15, 16 Dual-channel evaluation	Status 13, 14 Dual-channel evaluation	Status 11, 12 Dual-channel evaluation
Byte 2	Status 18	Status 17	Status 16	Status 15	Status 14	Status 13	Status 12	Status 11
Byte 3 ... 7	Reserved							

Module status bits for XTDO

Table 166: Module status bits for XTDO

	Bit 7	Bit 6	Bit 5	Bit 4	Bit 3	Bit 2	Bit 1	Bit 0
Byte 0	Reserved	Fast shut off status (all grouped)	Auxiliary voltage supply	Reserved		External error	Reserved	
Byte 1	Reserved				Status 17, 18 Dual-channel evaluation	Status 15, 16 Dual-channel evaluation	Status 13, 14 Dual-channel evaluation	Status 11, 12 Dual-channel evaluation
Byte 2	Status 18	Status 17	Status 16	Status 15	Status 14	Status 13	Status 12	Status 11
Byte 3	Status Q4 Short-circuit to Low	Status Q4 Short-circuit to High	Status Q3 Short-circuit to Low	Status Q3 Short-circuit to High	Status Q2 Short-circuit to Low	Status Q2 Short-circuit to High	Status Q1 Short-circuit to Low	Status Q1 Short-circuit to High
Byte 4 ... 6	Reserved							
Byte 7	Status Q8 Short-circuit to Low	Status Q8 Short-circuit to High	Status Q7 Short-circuit to Low	Status Q7 Short-circuit to High	Status Q6 Short-circuit to Low	Status Q6 Short-circuit to High	Status Q5 Short-circuit to Low	Status Q5 Short-circuit to High

Module status bits for gateway

Table 167: PROFINET gateway module status bits

	Bit 7	Bit 6	Bit 5	Bit 4	Bit 3	Bit 2	Bit 1	Bit 0
Byte 0	Reserved	Data valid Gateway → network	Data valid Network → Gateway	Reserved		External error	Reserved	
Byte 1	Reserved	Matching submodule selection	Status of process data transmission ¹⁾	Reserved				
Byte 2 ... 3	Reserved							
Byte 4	Reserved				Socket 4 client status	Socket 3 client status	Socket 2 client status	Socket 1 client status
Byte 5 ... 7	Reserved							

1) PROFINET: If a configured connection cannot be established after 90 s, the **Status of process data transmission** bit = 0.
 TCP socket interface (gateway as client): If a configured connection cannot be established after 60 s, the **Socket X Client Status** bit = 0. The **Socket X Client Status** bit is also 0 if an already established client connection is terminated.

Table 168: EtherCAT® gateway module status bits

	Bit 7	Bit 6	Bit 5	Bit 4	Bit 3	Bit 2	Bit 1	Bit 0
Byte 0	Reserved	Reserved	Data valid Network → Gateway	Reserved		External error	Reserved	
Byte 1 ... 7	Reserved							

Table 169: CANopen gateway module status bits

	Bit 7	Bit 6	Bit 5	Bit 4	Bit 3	Bit 2	Bit 1	Bit 0
Byte 0	Reserved	Data valid Gateway → network	Data valid Network → Gateway	Reserved		External error	Reserved	
Byte 1	CAN list mode status	Reserved	Status of process data transmission ^{1) 2)}	CAN controller status	Reserved			
Byte 2	Listener status 08	Listener status 07	Listener status 06	Listener status 05	Listener status 04	Listener status 03	Listener status 02	Listener status 01
Byte 3	Listener status 16	Listener status 15	Listener status 14	Listener status 13	Listener status 12	Listener status 11	Listener status 10	Listener status 09
Byte 4 ... 7	Reserved							

1) CANopen and CAN list mode: If a configured connection cannot be established after 90 s, the Status of process data transmission bit = 0.
 2) If heartbeat or node guarding was activated via the client, the receiver indicates an error, and CANopen process data was sent, the Status of process data transmission bit = 0.

Complementary information

- The module status bits have the following meanings:
 - 0 = Error
 - 1 = No error
- If a module is not present, all bits of the module are set to logical 1.
- Bits reserved for future use are always logical 1.
- The status bytes of each module are transmitted as a 32-bit word in big endian format, i.e. the most significant byte (MSB = byte 3) is transmitted first and the least significant byte (LSB = byte 0) last.

13.3.1.2 Modbus® TCP holding register

13.3.1.2.1 Commands

Commands

Table 170: Modbus® TCP – output data

Address	Contents	Size	Description
256	Output data	1 word (2 bytes)	Is specified in the higher-level controller.
...		1 word (2 bytes)	
280		1 word (2 bytes)	
356	Find me function	1 word (2 bytes, MSB always 0)	0: Standard operation of the LEDs 1: Flash mode for 30 seconds ¹⁾

1) A change from 1 to 0 ends the flash mode.

Complementary information

- The output data is written dynamically. From address 256, a client can write up to 25 words (50 bytes) of output data. From address 257, a client can write up to 24 words (48 bytes) of output data, etc.

13.3.2 SLMP

Overview

The safety controller supports an SLMP server without a safety protocol.

SLMP (Seamless Messaging Protocol) is used for communication in CC-Link systems. SLMP allows you to read and write data ranges completely or only up to a smaller data quantity (\leq total size).

Supported commands

- 0x0613 Read memory
- 0x1613 Write memory
- 0x0E30 Node search

13.3.2.1 SLMP input data

13.3.2.1.1 Process data to the higher-level controller

Process data to the higher-level controller

Table 171: Process data to the higher-level controller

Address	Contents	Size
0	Configured process data	25 words (50 bytes)

You configure the contents in the configuration software.

13.3.2.1.2 Checksums

Table 172: Checksums

Address	Contents	Data type	Size
150 most significant word 151 least significant word	Overall checksum value	CRC32	2 words (4 bytes)
152 most significant word 153 least significant word	Safety checksum	CRC32	2 words (4 bytes)
154 most significant word 155 least significant word	Standard checksum	CRC32	2 words (4 bytes)
156 most significant word 157 least significant word	Reserved	CRC32	2 words (4 bytes)
158 most significant word 159 least significant word	Verification checksum	CRC32	2 words (4 bytes)

13.3.2.1.3 Product codes

Table 173: Product codes

Address	Contents	Data type	Size
200	Product codes ¹⁾ : <ul style="list-style-type: none"> • Product code of the CPU (4 bytes) • Product code of the SmartPlug (4 bytes) • Product codes of the expansion modules (4 bytes each) 	UINT32	100 words (200 bytes)

¹⁾ Unavailable data are padded with "0".

13.3.2.1.4 Status

Table 174: Status

Address	Contents	Size
350	SystemStatusInfo ¹⁾	208 words (416 bytes)

¹⁾ Unavailable data are padded with "0xFF".

13.3.2.1.5 Device

Table 175: Device

Address	Contents	Data type	Size
714	Vendor name	ASCII STRING	4 words (8 bytes)
718	Product code	ASCII STRING	4 words (8 bytes)
722	Product name	ASCII STRING	16 words (32 bytes)
738	Model name	ASCII STRING	9 words (18 bytes)
747	Revision	ASCII STRING	6 words (12 bytes)
753	Serial number	ASCII STRING	12 words (24 bytes)
765	Application name	ASCII STRING	16 words (32 bytes)
781	Service number (internal use)	ASCII STRING	4 words (8 bytes)

13.3.2.1.6 Project data

Overview

Contains the project data from the configuration software of the safety controller.

Project data

Table 176: Project data

Address	Contents	Data type	Size
800	Device name	UTF8 STRING	32 words (64 bytes)
832	Project name	UTF8 STRING	32 words (64 bytes)
864	Application name	UTF8 STRING	32 words (64 bytes)
896	User name (optional)	UTF8 STRING	32 words (64 bytes)
928	Description	UTF8 STRING	50 words (100 bytes)

Complementary information

- Unused characters in the STRING are padded with blanks.

13.3.2.1.7 Find me function

Table 177: Find me function

Address	Contents	Size
1000	Find me function 0: Standard operation of the LEDs 1: Flash mode for 30 seconds ¹⁾	1 word (2 bytes)

¹⁾ A change from 1 to 0 ends the flash mode.

13.3.2.2 SLMP output data

13.3.2.2.1 Process data to the safety controller

Process data to the safety controller

Table 178: Process data to the safety controller

Address	Contents	Size
50	Process data	1 word (2 bytes)
...		1 word (2 bytes)
74		1 word (2 bytes)

Complementary information

- The process data is written and read dynamically. You can write or read up to 25 words (50 bytes) of process data at address 50. You can write or read up to 24 words (48 bytes) of process data from address 51 onwards.

13.4 Dimensional drawings

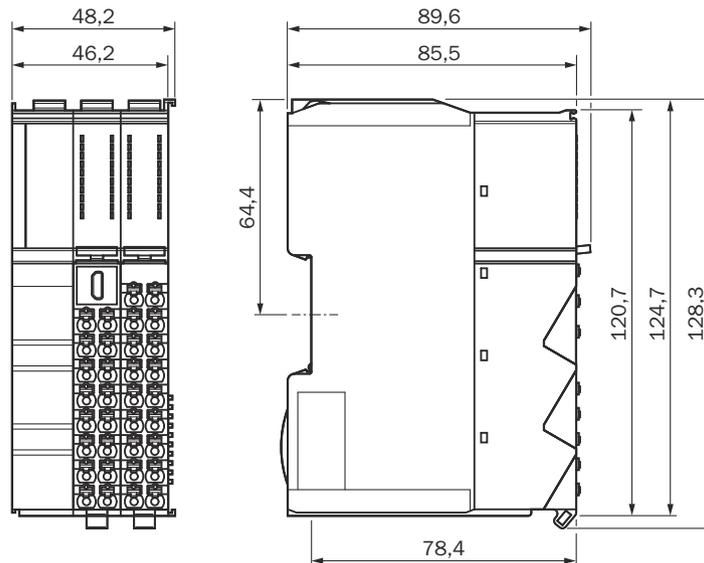

Figure 54: Dimensional drawing CPUc1

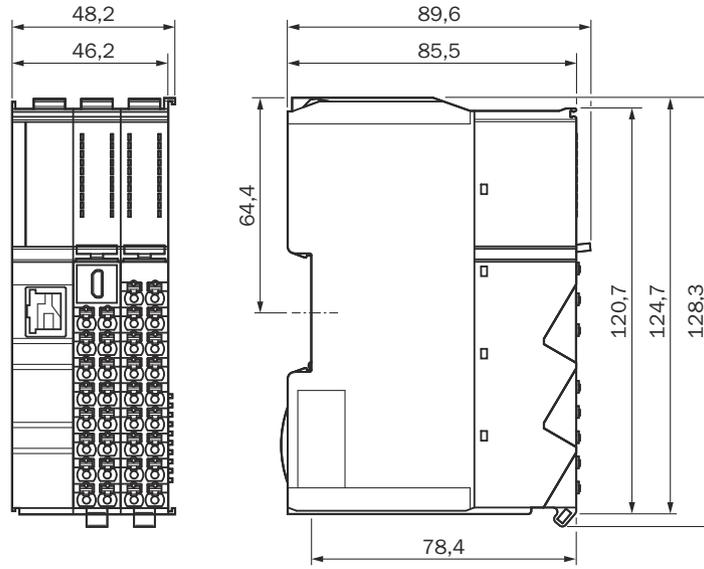

Figure 55: Dimensional drawing CPUc2

14 Ordering information

14.1 Scope of delivery

- Main module
- Housing end cap
- 2 front connectors incl. a SmartPlug
- Safety note
- Operating instructions for download: www.sick.com

14.2 Ordering information for main module

Table 179: Ordering information for main module

Part	Type code	Part number
CPUc1 main module <ul style="list-style-type: none"> • 20 safety capable inputs • 8 test outputs • 4 safety outputs 	FLX3-CPUC100	1085349
CPUc2 main module <ul style="list-style-type: none"> • 20 safety capable inputs • 8 test outputs • 4 safety outputs • Ethernet interface (female RJ45 Ethernet connector) for Modbus® TCP 	FLX3-CPUC200	1085351

14.3 Ordering information for expansion module

Ordering information for IO expansion module

Table 180: Ordering information for IO expansion module

Part	Type code	Part number
Expansion module XTDI1 <ul style="list-style-type: none"> • 8 safety capable inputs • 8 test outputs 	FLX3-XTDI100	1085353
Expansion module XTDO1 <ul style="list-style-type: none"> • 8 safety capable inputs • 8 safety outputs 	FLX3-XTDO100	1085354

Ordering information for gateway expansion module

Table 181: Ordering information for gateway expansion module

Part	Type code	Part number
GPNT1 PROFINET-IO gateway	FLX0-GPNT100	1085356
GETC1 EtherCAT® gateway	FLX0-GETC100	1085357
The GCAN1 CANopen gateway	FLX0-GCAN100	1085363

14.4 Ordering information for accessories

Table 182: Ordering information for accessories

Part	Type code	Part number
Front connector with opening for SmartPlug <ul style="list-style-type: none"> • 16 spring terminals 	FLX0-ACC0300	6069666

Part	Type code	Part number
Front connector <ul style="list-style-type: none">• 18 spring terminals	FLX0-ACC0200	6066285
SmartPlug	FLX3-SMPL100	2106852
Housing end cap	FLX0-ACC0400	5340579

15 Annex

15.1 Conformities and certificates

You can obtain declarations of conformity, certificates, and the current operating instructions for the product at www.sick.com. To do so, enter the product part number in the search field (part number: see the entry in the “P/N” or “Ident. no.” field on the type label).

15.1.1 EU declaration of conformity

Excerpt

The undersigned, representing the manufacturer, herewith declares that the product is in conformity with the provisions of the following EU directive(s) (including all applicable amendments), and that the standards and/or technical specifications stated in the EU declaration of conformity have been used as a basis for this.

- ROHS DIRECTIVE 2011/65/EU
- EMC DIRECTIVE 2014/30/EU
- MACHINERY DIRECTIVE 2006/42/EC

15.1.2 UK declaration of conformity

Excerpt

The undersigned, representing the following manufacturer herewith declares that this declaration of conformity is issued under the sole responsibility of the manufacturer. The product of this declaration is in conformity with the provisions of the following relevant UK Statutory Instruments (including all applicable amendments), and the respective standards and/or technical specifications have been used as a basis.

- Restriction of the Use of Certain Hazardous Substances in Electrical and Electronic Equipment Regulations 2012
- Electromagnetic Compatibility Regulations 2016
- Supply of Machinery (Safety) Regulations 2008

16 List of figures

1.	Example maximum configuration.....	12
2.	FLX3-CPUC1 module.....	13
3.	FLX3-CPUC2 module.....	13
4.	LEDs for indicating the status.....	15
5.	SmartPlug.....	16
6.	Clearances for adequate air circulation.....	19
7.	Safety requirements when mounting the muting sensors.....	20
8.	Detection of material during muting.....	21
9.	Muting with two sensor pairs arranged in parallel (A1 / A2 and B1 / B2).....	22
10.	Muting with two sensor pairs arranged in sequence (A1 / A2 and B1 / B2).....	22
11.	Muting with a sensor pair arranged crosswise (A1 / A2).....	22
12.	Example for parallel muting.....	24
13.	Example for sequential muting.....	25
14.	Example for cross muting.....	26
15.	Internal circuitry main module.....	28
16.	Main module mounting.....	33
17.	Expansion module mounting.....	33
18.	Housing end cap and end clamp mounting.....	34
19.	Pull out the front connector.....	35
20.	Dismantle front connector.....	36
21.	Mount the front connector.....	37
22.	Terminals on front connectors.....	38
23.	Eyelet on front connector.....	40
24.	Software controls.....	43
25.	Configuration.....	47
26.	Edit mode button.....	47
27.	Logic editor.....	59
28.	Sequence/timing diagram Fixed off-delay timer V1.....	68
29.	Sequence/timing diagram Adjustable on-delay timer V1.....	69
30.	Sequence/timing diagram Adjustable off-delay timer V1.....	71
31.	Parameter diagram.....	72
32.	Sequence/timing diagram Clock generator V1.....	72
33.	Sequence/timing diagram Two hand control (4 inputs) V1.....	79
34.	Sequence/timing diagram Dual channel monitor V1.....	81
35.	Sequence/timing diagram Edge detection V1.....	82
36.	Sequence/timing diagram External device monitoring V1 without parameter Permanent monitoring of the feedback signal	85
37.	Sequence/timing diagram External device monitoring V1 without parameter Permanent monitoring of the feedback signal	85
38.	Release condition A is fulfilled. Robot movement is released.....	87
39.	Release condition B is fulfilled. Robot movement is released.....	87
40.	Release condition A and B are fulfilled. Robot movement is not released.....	87
41.	Example of Fast shut off V1 internal logic for alternative enable conditions.....	88
42.	Sequence/timing diagram Reset V1.....	90
43.	Sequence/timing diagram Restart V1.....	91
44.	Sequence/timing diagram Multi operator V1.....	93
45.	Sequence/timing diagram Operating mode switch V1.....	94
46.	Muting with two sensor pairs arranged in parallel (A1 / A2 and B1 / B2).....	96
47.	Sequence/timing diagram Parallel muting V1.....	98
48.	Muting with two sensor pairs arranged in sequence (A1 / A2 and B1 / B2).....	99
49.	Sequence/timing diagram Sequential muting V1.....	101
50.	Muting with a sensor pair arranged crosswise (A1 / A2).....	102
51.	Sequence/timing diagram Cross muting V1.....	104
52.	Sequence/timing diagram for Override and Override required.....	106

53. Safety controller response times.....	136
54. Dimensional drawing CPUc1.....	150
55. Dimensional drawing CPUc2.....	151

17 List of tables

1.	Available documents.....	7
2.	Interfaces of the main module.....	14
3.	Status indicator.....	15
4.	Monitoring functions for muting.....	23
5.	Muting wiring combinations and requirements.....	27
6.	Left front connector pin assignment.....	39
7.	Right front connector pin assignment.....	39
8.	User groups.....	44
9.	Categories of input elements.....	49
10.	Configuration options for input elements.....	50
11.	Dual-channel evaluation.....	51
12.	Categories of output elements.....	52
13.	Configuration options for output elements.....	53
14.	Colors of the bytes and bits of a record.....	57
15.	Colors of the bytes and bits of a record.....	58
16.	Inputs NOT V1.....	60
17.	Outputs NOT V1.....	60
18.	Inputs AND V1.....	60
19.	Outputs AND V1.....	61
20.	Parameter AND V1.....	61
21.	Inputs OR V1.....	61
22.	Outputs OR V1.....	61
23.	Parameter OR V1.....	61
24.	Inputs XOR V1.....	61
25.	Outputs XOR V1.....	61
26.	Inputs XNOR V1.....	62
27.	Outputs XNOR V1.....	62
28.	Inputs RS Flip-Flop V1.....	62
29.	Outputs RS Flip-Flop V1.....	62
30.	Parameter RS Flip-Flop V1.....	62
31.	RS Flip-Flop V1 truth table without inversion.....	62
32.	Inputs JK Flip-Flop V1.....	63
33.	Outputs JK Flip-Flop V1.....	63
34.	Parameter JK Flip-Flop V1.....	63
35.	JK Flip-Flop V1 truth table without input inversion.....	63
36.	Inputs UInt8 to One-hot V1.....	64
37.	Outputs UInt8 to One-hot V1.....	64
38.	Parameter UInt8 to One-hot V1.....	64
39.	Inputs One-hot to UInt8 V1.....	64
40.	Outputs One-hot to UInt8 V1.....	64
41.	Parameter One-hot to UInt8 V1.....	65
42.	Inputs UInt8 to Bool V1.....	65
43.	Outputs UInt8 to Bool V1.....	65
44.	Truth table UInt8 to Bool V1.....	66
45.	Inputs Bool to UInt8 V1.....	66
46.	Outputs Bool to UInt8 V1.....	66
47.	Truth table Bool to UInt8 V1.....	66
48.	Inputs Fixed on-delay timer V1.....	67
49.	Outputs Fixed on-delay timer V1.....	67
50.	Parameter Fixed on-delay timer V1.....	67
51.	Inputs Fixed off-delay timer V1.....	67
52.	Outputs Fixed off-delay timer V1.....	67
53.	Parameter Fixed off-delay timer V1.....	68
54.	Inputs Adjustable on-delay timer V1.....	68

55. Outputs Adjustable on-delay timer V1.....69

56. Parameter Adjustable on-delay timer V1..... 69

57. Inputs Adjustable off-delay timer V1..... 70

58. Outputs Adjustable off-delay timer V1..... 70

59. Parameter Adjustable off-delay timer V1..... 70

60. Inputs Clock generator V1.....71

61. Outputs Clock generator V1..... 71

62. Parameter Clock generator V1.....72

63. Inputs Event counter (up) V1..... 73

64. Outputs Event counter (up) V1.....73

65. Parameter Event counter (up) V1..... 73

66. Inputs Event counter (down) V1.....74

67. Outputs Event counter (down) V1.....74

68. Parameter Event counter (down) V1.....74

69. Inputs Event counter (up and down) V1.....75

70. Outputs Event counter (up and down) V1.....75

71. Parameter Event counter (up and down) V1.....75

72. Inputs Two hand control (2 inputs) V1.....76

73. Outputs Two hand control (2 inputs) V1.....76

74. Inputs Two hand control (4 inputs) V1.....77

75. Outputs Two hand control (4 inputs) V1.....77

76. Parameter Two hand control (4 inputs) V1.....78

77. Possible statuses of an input pair.....79

78. Inputs Dual channel monitor V1.....79

79. Outputs Dual channel monitor V1.....80

80. Parameter Dual channel monitor V1.....80

81. Truth table Dual channel monitor V1.....80

82. Inputs Edge detection V1.....81

83. Outputs Edge detection V1.....81

84. Parameter Edge detection V1.....82

85. Inputs External device monitoring V1.....83

86. Outputs External device monitoring V1.....83

87. Parameter External device monitoring V1.....83

88. Errors and reset conditions.....84

89. Inputs Fast shut off V1.....86

90. Outputs Fast shut off V1.....86

91. Parameter Fast shut off V1.....86

92. Response times.....88

93. Inputs Reset V1.....89

94. Outputs Reset V1.....89

95. Inputs Restart V1.....90

96. Outputs Restart V1.....91

97. Inputs Multi operator V1.....92

98. Outputs Multi operator V1.....92

99. Parameter Multi operator V1.....92

100. Inputs Operating mode switch V1.....93

101. Outputs Operating mode switch V1.....93

102. Parameter Operating mode switch V1.....94

103. Inputs Multi enable V1.....95

104. Outputs Multi enable V1.....95

105. Parameter Multi enable V1.....95

106. Inputs Multi latch V1.....95

107. Outputs Multi latch V1.....95

108. Parameter Multi latch V1.....96

109. Inputs Parallel muting V1.....96

110. Outputs Parallel muting V1.....97

111. Parameter Parallel muting V1.....97

112. Inputs Sequential muting V1.....	99
113. Outputs Sequential muting V1.....	99
114. Parameter Sequential muting V1.....	100
115. Valid sequence for muting sensor input signals with sequence monitoring.....	102
116. Inputs Cross muting V1.....	102
117. Outputs Cross muting V1.....	103
118. Parameter Cross muting V1.....	103
119. Conditions for Override required and when override is possible.....	105
120. Number of permissible override cycles.....	106
121. Effect of the Conveyor input.....	107
122. Error statuses and reset information for muting function blocks.....	108
123. Process data status bits of the modules.....	110
124. Process data status bits of the individual inputs or outputs.....	111
125. PWR and CV indications.....	121
126. CV indications.....	121
127. I indications (safety capable input).....	122
128. I indications (safety capable input) - Flexi Loop.....	122
129. Q indications (safety output).....	122
130. X indications (test output).....	123
131. Faults in the logic.....	125
132. Faults in the safety capable inputs (I).....	125
133. Faults in the safety outputs (Q).....	126
134. Faults in the test outputs (X).....	126
135. Error history information.....	127
136. Safety-related characteristic data - safety capable inputs (I).....	130
137. Safety-related characteristic data - CPU logic processing.....	130
138. Safety-related characteristic data - safety outputs (Q).....	131
139. General data.....	131
140. Voltage supply.....	132
141. Technical data for the safety capable inputs (I).....	133
142. Technical data for the test outputs (X) when used with safety capable inputs....	133
143. Technical data when using test outputs (X) as non-safe outputs (PNP or NPN)..	134
144. Technical data for the safety outputs (Q).....	134
145. Network interface of the main module.....	135
146. Calculating the maximum response time.....	136
147. IN1 - Response time of safety inputs (I).....	137
148. IN3 ... IN5 - Response time for processing of incoming process data.....	137
149. OUT1 - Response time of safety outputs (Q).....	138
150. OUT2 - Response time of test outputs (X).....	138
151. OUT3 ... OUT5 - Response time for processing of outgoing process data.....	138
152. IN1 - Response time of safety capable inputs (I).....	139
153. OUT1 - Response time of safety outputs (Q).....	139
154. Calculating the maximum response time - signal path 1.....	140
155. IN1 - Response time of safety capable inputs (I).....	140
156. OUT3 ... OUT5 - Response time for processing of outgoing process data.....	141
157. Calculating the maximum response time - signal path 2.....	141
158. Modbus® TCP - Device identification.....	142
159. Modbus® TCP - Input data.....	143
160. Modbus® TCP - Checksums, status information and metadata.....	143
161. Device status.....	144
162. Required user action.....	144
163. Product codes.....	144
164. Module status bits for main module.....	145
165. Module status bits for XTDL.....	145
166. Module status bits for XTDO.....	146
167. PROFINET gateway module status bits.....	146
168. EtherCAT® gateway module status bits.....	146

169. CANopen gateway module status bits.....	147
170. Modbus® TCP – output data.....	147
171. Process data to the higher-level controller.....	148
172. Checksums.....	148
173. Product codes.....	148
174. Status.....	148
175. Device.....	149
176. Project data.....	149
177. Find me function.....	149
178. Process data to the safety controller.....	150
179. Ordering information for main module.....	152
180. Ordering information for IO expansion module.....	152
181. Ordering information for gateway expansion module.....	152
182. Ordering information for accessories.....	152

Australia
Phone +61 (3) 9457 0600
1800 33 48 02 – tollfree
E-Mail sales@sick.com.au

Austria
Phone +43 (0) 2236 62288-0
E-Mail office@sick.at

Belgium/Luxembourg
Phone +32 (0) 2 466 55 66
E-Mail info@sick.be

Brazil
Phone +55 11 3215-4900
E-Mail comercial@sick.com.br

Canada
Phone +1 905.771.1444
E-Mail cs.canada@sick.com

Czech Republic
Phone +420 234 719 500
E-Mail sick@sick.cz

Chile
Phone +56 (2) 2274 7430
E-Mail chile@sick.com

China
Phone +86 20 2882 3600
E-Mail info.china@sick.net.cn

Denmark
Phone +45 45 82 64 00
E-Mail sick@sick.dk

Finland
Phone +358-9-25 15 800
E-Mail sick@sick.fi

France
Phone +33 1 64 62 35 00
E-Mail info@sick.fr

Germany
Phone +49 (0) 2 11 53 010
E-Mail info@sick.de

Greece
Phone +30 210 6825100
E-Mail office@sick.com.gr

Hong Kong
Phone +852 2153 6300
E-Mail ghk@sick.com.hk

Hungary
Phone +36 1 371 2680
E-Mail ertesites@sick.hu

India
Phone +91-22-6119 8900
E-Mail info@sick-india.com

Israel
Phone +972 97110 11
E-Mail info@sick-sensors.com

Italy
Phone +39 02 27 43 41
E-Mail info@sick.it

Japan
Phone +81 3 5309 2112
E-Mail support@sick.jp

Malaysia
Phone +603-8080 7425
E-Mail enquiry.my@sick.com

Mexico
Phone +52 (472) 748 9451
E-Mail mexico@sick.com

Netherlands
Phone +31 (0) 30 229 25 44
E-Mail info@sick.nl

New Zealand
Phone +64 9 415 0459
0800 222 278 – tollfree
E-Mail sales@sick.co.nz

Norway
Phone +47 67 81 50 00
E-Mail sick@sick.no

Poland
Phone +48 22 539 41 00
E-Mail info@sick.pl

Romania
Phone +40 356-17 11 20
E-Mail office@sick.ro

Russia
Phone +7 495 283 09 90
E-Mail info@sick.ru

Singapore
Phone +65 6744 3732
E-Mail sales.gsg@sick.com

Slovakia
Phone +421 482 901 201
E-Mail mail@sick-sk.sk

Slovenia
Phone +386 591 78849
E-Mail office@sick.si

South Africa
Phone +27 10 060 0550
E-Mail info@sickautomation.co.za

South Korea
Phone +82 2 786 6321/4
E-Mail infokorea@sick.com

Spain
Phone +34 93 480 31 00
E-Mail info@sick.es

Sweden
Phone +46 10 110 10 00
E-Mail info@sick.se

Switzerland
Phone +41 41 619 29 39
E-Mail contact@sick.ch

Taiwan
Phone +886-2-2375-6288
E-Mail sales@sick.com.tw

Thailand
Phone +66 2 645 0009
E-Mail marcom.th@sick.com

Turkey
Phone +90 (216) 528 50 00
E-Mail info@sick.com.tr

United Arab Emirates
Phone +971 (0) 4 88 65 878
E-Mail contact@sick.ae

United Kingdom
Phone +44 (0)17278 31121
E-Mail info@sick.co.uk

USA
Phone +1 800.325.7425
E-Mail info@sick.com

Vietnam
Phone +65 6744 3732
E-Mail sales.gsg@sick.com

Detailed addresses and further locations at www.sick.com

