



## UP56

TOUGH, NON-CONTACT, PRESSURE-RESISTANT

Level sensors

**SICK**  
Sensor Intelligence.

# TOUGH, NON-CONTACT, PRESSURE-RESISTANT



## Product description

The product family UP56 of ultrasonic level sensors is the ideal solution for demanding applications. The teflon-protected transducer handles overpressure up to 6 bar (87 psi) and is resistant against numerous difficult fluids. Wetted parts can be chosen either as stainless steel or PVDF, thus making the UP56 the perfect solution for measurement in aggressive, viscous, or abrasive liquids, or bulk solids. By combining two output

signals in one device, new cost-effective solutions can be created for measurement and integration into the system. With two switching outputs, the UP56 can measure dry running and overflow in one device. Combining analog and a switching output enables continuous level measurement with a separate overflow signal. Parameters are easy to set via an integrated display, PC or the connect+ adapter.

## At a glance

- Non-contact measurement up to 3.4 m operating distance / 8.0 m scanning distance limit
- Pressure resistant up to 6 bar
- Converter protected by PVDF cover for increased resistance
- 3-in-1: Continuous measurement, switching signal, and display
- Analog output can be switched 4 mA ... 20 mA and 0 V ... 10 V
- Process connector thread G 1 and G 2
- IP67 enclosure rating
- Simple operation, also via Connect+

## Your benefits

- Non-contact measurement in pressurized containers – no wear over time
- Easy to set parameters, saving time
- Flexible measurement system for different container sizes – standardization and stock reduction
- One product for point level and continuous applications, reduces the number of sensors required



## Additional information

Detailed technical data . . . . .	3
Type code . . . . .	4
Ordering information . . . . .	4
Connection type . . . . .	5
Recommended accessories . . . . .	7

→ [www.sick.com/UP56](http://www.sick.com/UP56)

For more information, simply enter the link or scan the QR code and get direct access to technical data, CAD design models, operating instructions, software, application examples, and much more.



## Detailed technical data

## Features

	UP56-211	UP56-212	UP56-213	UP56-214
<b>Medium</b>	Fluids, bulk solids			
<b>Measurement</b>	Switch, Continuous			
<b>Measuring range in tank</b>	30 mm ... 250 mm	85 mm ... 350 mm	200 mm ... 1,300 mm	350 mm ... 3,400 mm
<b>Measuring range immersion tube</b>	30 mm ... 990 mm <sup>1)</sup>	85 mm ... 1,500 mm <sup>1)</sup>	200 mm ... 5,000 mm <sup>1)</sup>	350 mm ... 8,000 mm <sup>1)</sup>
<b>Process pressure</b>	0 bar ... 6 bar, gauge pressure			
<b>Process temperature</b>	-25 °C ... +70 °C			

<sup>1)</sup> At 6 bar gauge.

## Performance

	UP56-211	UP56-212	UP56-213	UP56-214
<b>Accuracy of sensor element</b>	≤ 2 % <sup>1)</sup>			
<b>Repeatability</b>	± 0.15 % <sup>1)</sup>			
<b>Resolution</b>	≤ 0.18 mm			
<b>Response time</b>	≤ 68 ms <sup>2)</sup>	≤ 84 ms <sup>2)</sup>	≤ 180 ms <sup>2)</sup>	≤ 240 ms <sup>2)</sup>

<sup>1)</sup> From the full scale value.

<sup>2)</sup> Recovery time 32 ms ... 180 ms according to EMC EN 60947-5-7.

## Mechanics

	UP56-211	UP56-212	UP56-213	UP56-214
<b>Process connection</b>	G 1 A / 1" NPT (depending on type)			G 2 A PN 6 / 2" NPT (depending on type)
<b>Housing material</b>	Stainless steel 1.4571 / PBT / TPU (depending on type)			Stainless steel 1.4571 PBT TPU PVDF (depending on type)
<b>Weight</b>	210 g / 350 g (depending on type)			1,200 g / 350 g (depending on type)

## Electronics

	UP56-211	UP56-212	UP56-213	UP56-214
<b>Supply voltage</b>	9 V DC ... 30 V DC <sup>1)</sup>			
<b>Residual ripple</b>	± 10 %			
<b>Power consumption</b>	≤ 80 mA <sup>2)</sup>			
<b>Electrical connection</b>	Round connector M12 x 1, 5-pin			
<b>Output signal</b>	1 x PNP + 4 mA ... 20 mA / 0 V ... 10 V <sup>3) 4)</sup> 2 x PNP 2 x NPN (depending on type)			
<b>Hysteresis</b>	3 mm	5 mm	20 mm	50 mm
<b>Signal voltage HIGH</b>	U <sub>v</sub> -3 V			
<b>Time delay before availability</b>	≤ 300 ms			

<sup>1)</sup> Reverse-polarity protected.

<sup>2)</sup> At 24 V DC without output load.

<sup>3)</sup> Short-circuit protected, reversible.

<sup>4)</sup> , Automatic switching between voltage and current outputs dependet on load 4 mA ... 20 mA: RL ≤ 100 / at 9 V ≤ U<sub>B</sub> ≤ 20 V; RL ≤ 500/ at U<sub>B</sub> ≥ 20 V; 0 V ... 10 V: RL ≥ 100 k / at U<sub>B</sub> ≥ 15 V, short-circuit protected.

	UP56-211	UP56-212	UP56-213	UP56-214
<b>Enclosure rating</b>	IP 67			
<b>Ultrasonic frequency</b>	320 kHz		180 kHz	120 kHz
<b>Ultrasonic transducer</b>	PTFE coating, FFKM			

<sup>1)</sup> Reverse-polarity protected.

<sup>2)</sup> At 24 V DC without output load.

<sup>3)</sup> Short-circuit protected, reversible.

<sup>4)</sup> Automatic switching between voltage and current outputs dependet on load 4 mA ... 20 mA: RL ≤ 100 / at 9 V ≤ U<sub>B</sub> ≤ 20 V; RL ≤ 500 / at U<sub>B</sub> ≥ 20 V; 0 V ... 10 V: RL ≥ 100 k / at U<sub>B</sub> ≥ 15 V, short-circuit protected.

**Ambient data**

<b>Ambient operating temperature</b>	-25 °C ... +70 °C <sup>1)</sup>
<b>Ambient storage temperature</b>	-40 °C ... +85 °C

<sup>1)</sup> Temperature compensation at -25 °C ... +50 °C, can be switched off.

**Type code**

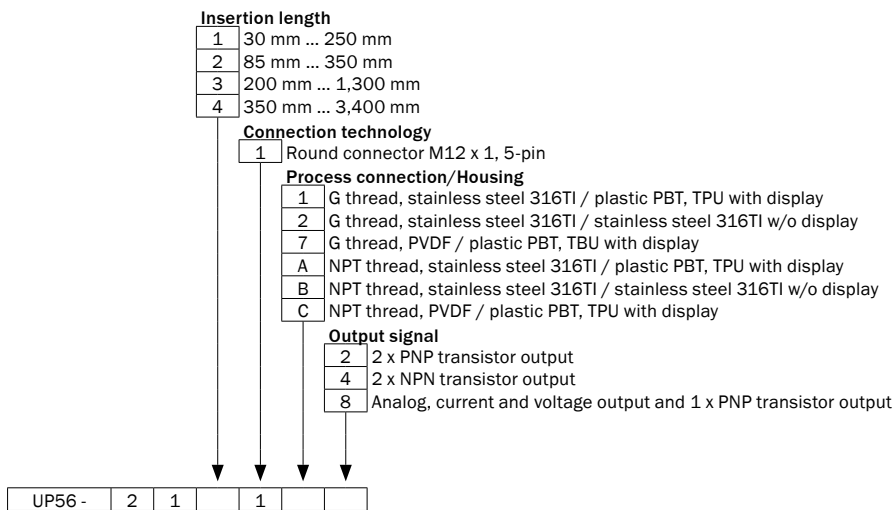

Not all variations of the type code can be combined!

**Ordering information**

- **Enclosure rating:** IP 67
- **Process temperature:** -25 °C ... +70 °C
- **Process pressure:** 0 bar ... 6 bar
- **Electrical connection:** round connector M12 x 1, 5-pin

Process connection	Output signal	Housing material	Operating distance	Limiting scanning distance	Type	Part no.
G 1 A	2 x PNP	Stainless steel 1.4571, PBT, TPU	30 mm ... 250 mm	30 mm ... 990 mm <sup>1)</sup>	UP56-211112	6041661
	2 x NPN	Stainless steel 1.4571, PBT, TPU	30 mm ... 250 mm	30 mm ... 990 mm <sup>1)</sup>	UP56-211114	6041664
	1 x PNP + 4 mA ... 20 mA / 0 V ... 10 V	Stainless steel 1.4571, PBT, TPU	30 mm ... 250 mm	30 mm ... 990 mm <sup>1)</sup>	UP56-211118	6041658
		Stainless steel 1.4571	30 mm ... 250 mm	30 mm ... 990 mm <sup>1)</sup>	UP56-211128	6048700
1" NPT	1 x PNP + 4 mA ... 20 mA / 0 V ... 10 V	Stainless steel 1.4571, PBT, TPU	30 mm ... 250 mm	30 mm ... 990 mm <sup>1)</sup>	UP56-2111A8	6054782

<sup>1)</sup> At 6 bar gauge.

Process connection	Output signal	Housing material	Operating distance	Limiting scanning distance	Type	Part no.
G 1 A	2 x PNP	Stainless steel 1.4571, PBT, TPU	85 mm ... 350 mm	85 mm ... 1,500 mm <sup>1)</sup>	UP56-212112	6041662
	2 x NPN	Stainless steel 1.4571, PBT, TPU	85 mm ... 350 mm	85 mm ... 1,500 mm <sup>1)</sup>	UP56-212114	6041665
	1 x PNP + 4 mA ... 20 mA / 0 V ... 10 V	Stainless steel 1.4571, PBT, TPU	85 mm ... 350 mm	85 mm ... 1,500 mm <sup>1)</sup>	UP56-212118	6041659
		Stainless steel 1.4571	85 mm ... 350 mm	85 mm ... 1,500 mm <sup>1)</sup>	UP56-212128	6048701
1" NPT	1 x PNP + 4 mA ... 20 mA / 0 V ... 10 V	Stainless steel 1.4571, PBT, TPU	85 mm ... 350 mm	85 mm ... 1,500 mm <sup>1)</sup>	UP56-2121A8	6054783
G 1 A	2 x PNP	Stainless steel 1.4571, PBT, TPU	200 mm ... 1,300 mm	200 mm ... 5,000 mm <sup>1)</sup>	UP56-213112	6041663
	2 x NPN	Stainless steel 1.4571, PBT, TPU	200 mm ... 1,300 mm	200 mm ... 5,000 mm <sup>1)</sup>	UP56-213114	6041666
	1 x PNP + 4 mA ... 20 mA / 0 V ... 10 V	Stainless steel 1.4571, PBT, TPU	200 mm ... 1,300 mm	200 mm ... 5,000 mm <sup>1)</sup>	UP56-213118	6041660
		Stainless steel 1.4571	200 mm ... 1,300 mm	200 mm ... 5,000 mm <sup>1)</sup>	UP56-213128	6048702
1" NPT	1 x PNP + 4 mA ... 20 mA / 0 V ... 10 V	Stainless steel 1.4571	200 mm ... 1,300 mm	200 mm ... 5,000 mm <sup>1)</sup>	UP56-2131A8	6054784
G 2 A PN 6	2 x PNP	Stainless steel 1.4571, PBT, TPU	350 mm ... 3,400 mm	350 mm ... 8,000 mm <sup>1)</sup>	UP56-214112	6041695
	2 x NPN	Stainless steel 1.4571, PBT, TPU	350 mm ... 3,400 mm	350 mm ... 8,000 mm <sup>1)</sup>	UP56-214114	6041694
	1 x PNP + 4 mA ... 20 mA / 0 V ... 10 V	Stainless steel 1.4571, PBT, TPU	350 mm ... 3,400 mm	350 mm ... 8,000 mm <sup>1)</sup>	UP56-214118	6041693
		Stainless steel 1.4571	350 mm ... 3,400 mm	350 mm ... 8,000 mm <sup>1)</sup>	UP56-214128	6048703
	2 x PNP	PVDF, PBT, TPU	350 mm ... 3,400 mm	350 mm ... 8,000 mm <sup>1)</sup>	UP56-214172	6039864
	2 x NPN	PVDF, PBT, TPU	350 mm ... 3,400 mm	350 mm ... 8,000 mm <sup>1)</sup>	UP56-214174	6039865
	1 x PNP + 4 mA ... 20 mA / 0 V ... 10 V	PVDF, PBT, TPU	350 mm ... 3,400 mm	350 mm ... 8,000 mm <sup>1)</sup>	UP56-214178	6039866
2" NPT	1 x PNP + 4 mA ... 20 mA / 0 V ... 10 V	PVDF, PBT, TPU	350 mm ... 3,400 mm	350 mm ... 8,000 mm <sup>1)</sup>	UP56-2141A8	6054014
					UP56-2141C8	6054786

<sup>1)</sup> At 6 bar gauge.

### Connection type

Male connector M12, 5-pin

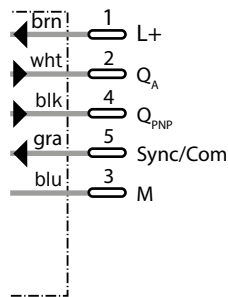

Detection range

Detection range UP56-211118

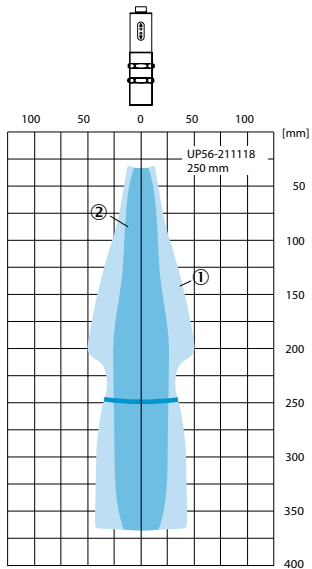

- ① Example object: aligned plate 500 mm x 500 mm
- ② Pipe diameter 10 mm

Detection range UP56-212118

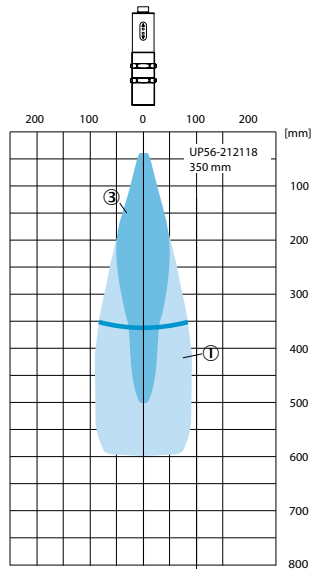

- ① Example object: aligned plate 500 mm x 500 mm
- ③ Pipe diameter 27 mm

Detection range UP56-213118

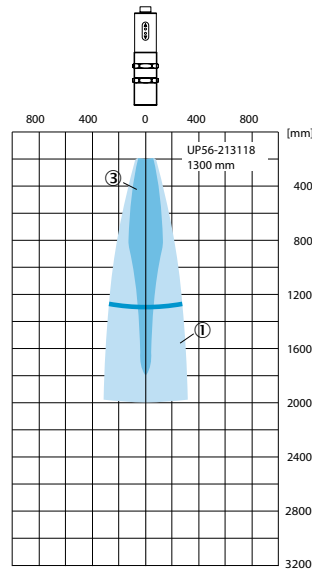

- ① Example object: aligned plate 500 mm x 500 mm
- ③ Pipe diameter 27 mm

Detection range UP56-2141\_8

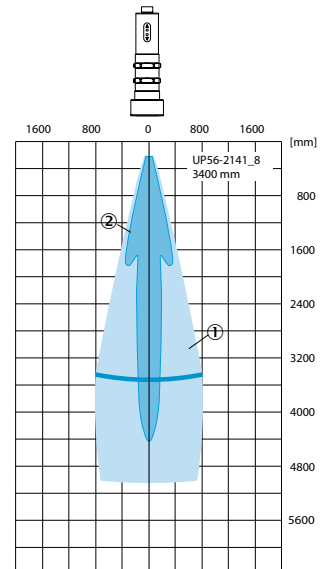

- ① Example object: aligned plate 500 mm x 500 mm
- ② Pipe diameter 10 mm

Dimensional drawing

UP56-211/ 212/ 213

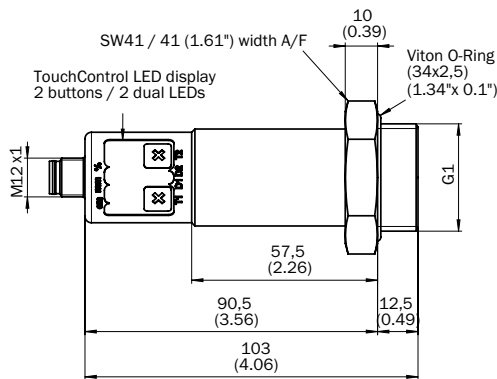

UP56-211/ 212/ 213 all-metal

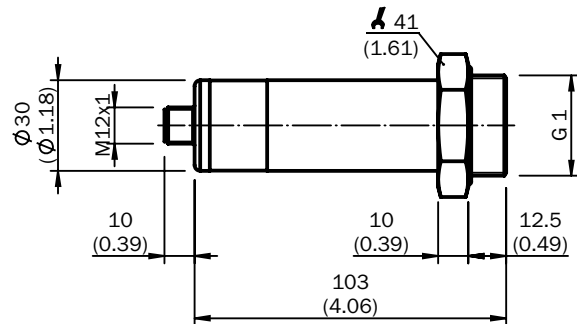

UP56-214

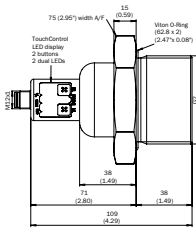

UP56-214 all-metal

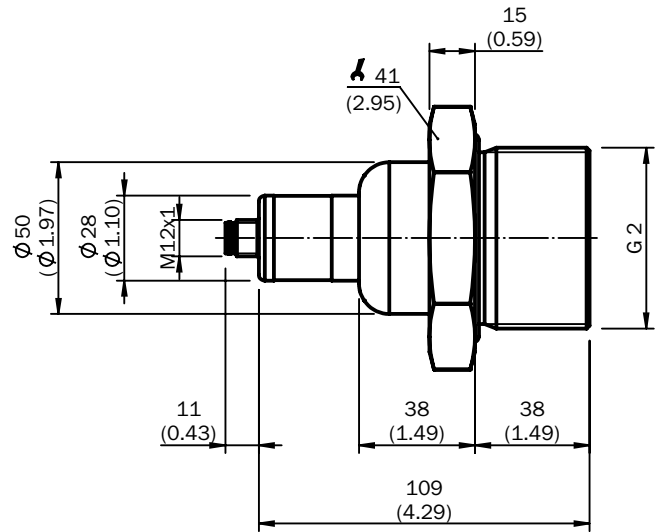

Recommended accessories

Mounting systems

Flanges



Weld-in flange



	Brief description	Type	Part no.
	Welded flange, process connection G 1, Stainless steel 1.4404	BEF-FL-316G10-UP56	4064295
	Welded flange/welded connector, process connection G 2, Stainless steel 1.4404	BEF-FL-316G20-UP56	4063263

Connection systems

Plug connectors and cables

Connecting cables with female connector

	Brief description	Cable length	Type	Part no.
 Illustration may differ	Head A: female connector, M12, 5-pin, straight Head B: cable Cable: PVC, unshielded	2 m	DOL-1205-G02M	6008899
	Head A: female connector, M12, 5-pin, straight Head B: cable Cable: drag chain use, PUR, halogen-free, unshielded	2 m	DOL-1205-G02MC	6025906
 Illustration may differ	Head A: female connector, M12, 5-pin, straight Head B: cable Cable: PVC, unshielded	5 m	DOL-1205-G05M	6009868
	Head A: female connector, M12, 5-pin, straight Head B: cable Cable: drag chain use, PUR, halogen-free, unshielded	5 m	DOL-1205-G05MC	6025907

	Brief description	Cable length	Type	Part no.
 Illustration may differ	Head A: female connector, M12, 5-pin, straight Head B: cable Cable: PVC, unshielded	10 m	DOL-1205-G10M	6010544
	Head A: female connector, M12, 5-pin, straight Head B: cable Cable: drag chain use, PUR, halogen-free, unshielded	10 m	DOL-1205-G10MC	6025908
 Illustration may differ	Head A: female connector, M12, 5-pin, angled Head B: cable Cable: PVC, unshielded	2 m	DOL-1205-W02M	6008900
	Head A: female connector, M12, 5-pin, angled Head B: cable Cable: drag chain use, PUR, halogen-free, unshielded	2 m	DOL-1205-W02MC	6025909
 Illustration may differ	Head A: female connector, M12, 5-pin, angled Head B: cable Cable: PVC, unshielded	5 m	DOL-1205-W05M	6009869
	Head A: female connector, M12, 5-pin, angled Head B: cable Cable: drag chain use, PUR, halogen-free, unshielded	5 m	DOL-1205-W05MC	6025910
 Illustration may differ	Head A: female connector, M12, 5-pin, angled Head B: cable Cable: PVC, unshielded	10 m	DOL-1205-W10M	6010542
	Head A: female connector, M12, 5-pin, angled Head B: cable Cable: drag chain use, PUR, halogen-free, unshielded	10 m	DOL-1205-W10MC	6025911

DOL-1205-G02M  
DOL-1205-G05M  
DOL-1205-G10M

DOL-1205-G02MC  
DOL-1205-G05MC  
DOL-1205-G10MC

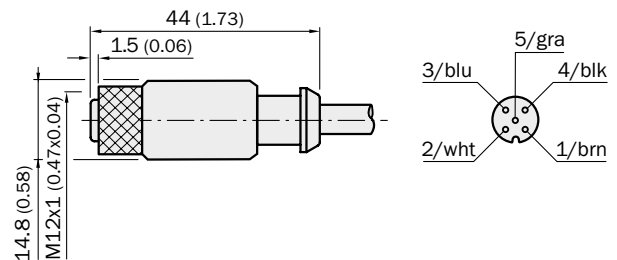
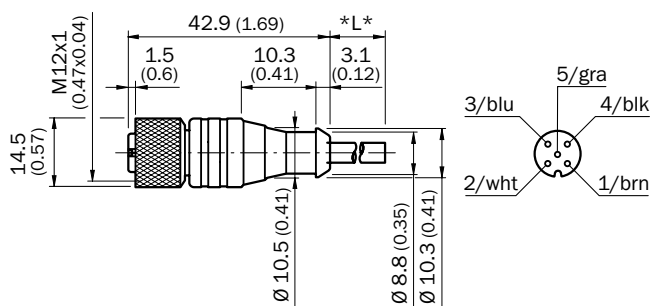



DOL-1205-W02M  
 DOL-1205-W05M  
 DOL-1205-W10M

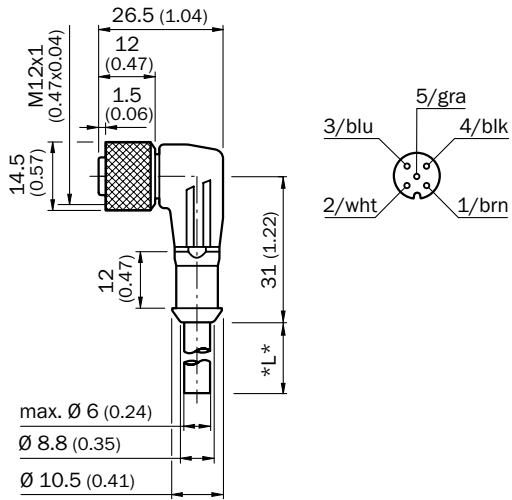

DOL-1205-W02MC  
 DOL-1205-W05MC  
 DOL-1205-W10MC

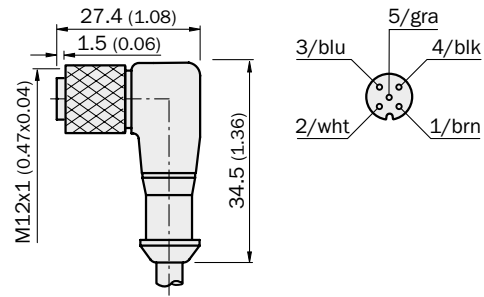

Further accessories

Programming and configuration tools

	Brief description	Type	Part no.
	Tool for visualization, configuration and cloning, 3-digit LED display, supply voltage: DV 9 V ... 30 V	Connect+ adapter (CPA)	6037782



## REGISTER AT WWW.SICK.COM TODAY AND ENJOY ALL THE BENEFITS



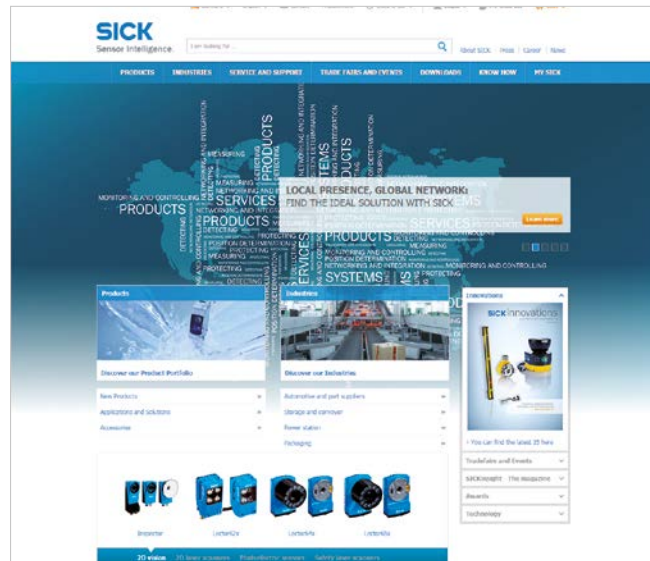

- ✔ Select products, accessories, documentation and software quickly and easily.
- ✔ Create, save and share personalized wish lists.
- ✔ View the net price and date of delivery for every product.
- ✔ Requests for quotation, ordering and delivery tracking made easy.
- ✔ Overview of all quotations and orders.
- ✔ Direct ordering: submit even very complex orders in moments.
- ✔ View the status of quotations and orders at any time. Receive e-mail notifications of status changes.
- ✔ Easily repeat previous orders.
- ✔ Conveniently export quotations and orders to work with your systems.



## SERVICES FOR MACHINES AND SYSTEMS: SICK LifeTime Services

Our comprehensive and versatile LifeTime Services are the perfect addition to the comprehensive range of products from SICK. The services range from product-independent consulting to traditional product services.



-  **Consulting and design**  
Safe and professional
-  **Product and system support**  
Reliable, fast and on-site
-  **Verification and optimization**  
Safe and regularly inspected
-  **Upgrade and retrofits**  
Easy, safe and economical
-  **Training and education**  
Practical, focused and professional

## SICK AT A GLANCE

SICK is a leading manufacturer of intelligent sensors and sensor solutions for industrial applications. With more than 7,400 employees and over 50 subsidiaries and equity investments as well as numerous agencies worldwide, we are always close to our customers. A unique range of products and services creates the perfect basis for controlling processes securely and efficiently, protecting individuals from accidents and preventing damage to the environment.

We have extensive experience in various industries and understand their processes and requirements. With intelligent sensors, we can deliver exactly what our customers need. In application centers in Europe, Asia and North America, system solutions are tested and optimized in accordance with customer specifications. All this makes us a reliable supplier and development partner.

Comprehensive services round out our offering: SICK LifeTime Services provide support throughout the machine life cycle and ensure safety and productivity.

**For us, that is “Sensor Intelligence.”**

### **Worldwide presence:**

Australia, Austria, Belgium, Brazil, Canada, Chile, China, Czech Republic, Denmark, Finland, France, Germany, Great Britain, Hungary, India, Israel, Italy, Japan, Malaysia, Mexico, Netherlands, New Zealand, Norway, Poland, Romania, Russia, Singapore, Slovakia, Slovenia, South Africa, South Korea, Spain, Sweden, Switzerland, Taiwan, Thailand, Turkey, United Arab Emirates, USA, Vietnam.

Detailed addresses and further locations → [www.sick.com](http://www.sick.com)