

LBR

Two-wire 4 ... 20 mA/HART



GB



Contents

1	For your safety	3
1.1	Authorised personnel	3
1.2	Appropriate use.....	3
1.3	Warning about incorrect use.....	3
1.4	General safety instructions	3
1.5	EU conformity.....	4
1.6	NAMUR recommendations	4
1.7	Radio license for Europe	4
2	Mounting.....	6
2.1	Mounting preparations, mounting strap	6
2.2	Mounting instructions	7
3	Connecting to power supply.....	8
3.1	Connecting.....	8
3.2	Wiring plan, single chamber housing.....	9
4	Set up with the display and adjustment module	10
4.1	Insert display and adjustment module	10
4.2	Parameter adjustment - Quick setup	10
4.3	Parameter adjustment - Extended adjustment.....	12
4.4	Menu overview	15
5	Supplement	18
5.1	Technical data	18



Information:

This quick setup guide enables quick setup and commissioning of your instrument.

You can find supplementary information in the corresponding, more detailed Operating Instructions Manual as well as the Safety Manual that comes with instruments with SIL qualification. These manuals are available on our homepage.

**Operating instructions LBR - Two-wire 4 ... 20 mA/HART:
Document-ID 62273**

Editing status of the quick setup guide: 2019-11-07

1 For your safety

1.1 Authorised personnel

All operations described in this documentation must be carried out only by trained, qualified personnel authorised by the plant operator.

During work on and with the device, the required personal protective equipment must always be worn.

1.2 Appropriate use

LBR is a sensor for continuous level measurement.

You can find detailed information about the area of application in chapter "*Product description*".

Operational reliability is ensured only if the instrument is properly used according to the specifications in the operating instructions manual as well as possible supplementary instructions.

1.3 Warning about incorrect use

Inappropriate or incorrect use of this product can give rise to application-specific hazards, e.g. vessel overflow through incorrect mounting or adjustment. Damage to property and persons or environmental contamination can result. Also, the protective characteristics of the instrument can be impaired.

1.4 General safety instructions

This is a state-of-the-art instrument complying with all prevailing regulations and directives. The instrument must only be operated in a technically flawless and reliable condition. The operator is responsible for the trouble-free operation of the instrument. When measuring aggressive or corrosive media that can cause a dangerous situation if the instrument malfunctions, the operator has to implement suitable measures to make sure the instrument is functioning properly.

During the entire duration of use, the user is obliged to determine the compliance of the necessary occupational safety measures with the current valid rules and regulations and also take note of new regulations.

The safety instructions in this operating instructions manual, the national installation standards as well as the valid safety regulations and accident prevention rules must be observed by the user.

For safety and warranty reasons, any invasive work on the device beyond that described in the operating instructions manual may be carried out only by personnel authorised by the manufacturer. Arbitrary conversions or modifications are explicitly forbidden. For safety reasons, only the accessory specified by the manufacturer must be used.

To avoid any danger, the safety approval markings and safety tips on the device must also be observed.

The low transmitting power of the radar sensor is far below the internationally approved limits. No health impairments are to be expected

with intended use. The band range of the transmission frequency can be found in chapter "*Technical data*".

1.5 EU conformity

The device fulfils the legal requirements of the applicable EU directives. By affixing the CE marking, we confirm the conformity of the instrument with these directives.

The EU conformity declaration can be found on our homepage.

1.6 NAMUR recommendations

NAMUR is the automation technology user association in the process industry in Germany. The published NAMUR recommendations are accepted as the standard in field instrumentation.

The device fulfils the requirements of the following NAMUR recommendations:

- NE 21 – Electromagnetic compatibility of equipment
- NE 43 – Signal level for fault information from measuring transducers
- NE 53 – Compatibility of field devices and display/adjustment components
- NE 107 – Self-monitoring and diagnosis of field devices

For further information see www.namur.de.

1.7 Radio license for Europe

The instrument was tested according to the latest issue of the following harmonized standards:

- EN 302372 - Tank Level Probing Radar
- EN 302729 - Level Probing Radar

It is hence approved for use inside and outside closed vessels in countries of the EU.

Use is also approved in EFTA countries, provided the respective standards have been implemented.

For operation inside of closed vessels, points a to f in annex E of EN 302372 must be fulfilled.

For operation outside of closed vessels, the following conditions must be fulfilled:

- The instrument must be stationary mounted and the antenna directed vertically downward
- The instrument may only be used outside closed vessels in the version with G1½ or 1½ NPT thread with integrated horn antenna.
- The mounting location must be at least 4 km away from radio astronomy stations, unless special permission was granted by the responsible national approval authority
- When installed within 4 to 40 km of a radio astronomy station, the instrument must not be mounted higher than 15 m above the ground.

A list of the respective radio astronomy stations can be found in chapter "*Appendix*" of the operating instructions.

2 Mounting

2.1 Mounting preparations, mounting strap

The mounting strap is supplied unassembled (optionally) and must be screwed to the sensor before setup with three hexagon socket screws M5 x 10 and spring washers. Max. torque, see chapter "*Technical data*". Required tools: Allen wrench size 4.

There are two different variants of screwing the strap to the sensor, see following illustration:

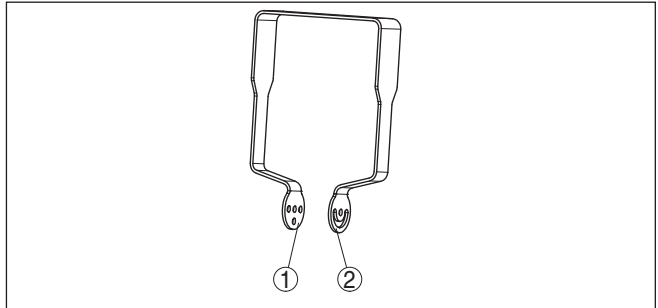

Fig. 1: Mounting strap for screwing to the sensor

- 1 For angle of inclination in steps
- 2 For angle of inclination, infinitely variable

Depending on the selected variant, the sensor can be rotated in the strap:

- Single chamber housing
 - Angle of inclination in three steps 0°, 90° and 180°
 - Angle of inclination 180°, infinitely variable
- Double chamber housing
 - Angle of inclination in two steps 0° and 90°
 - Angle of inclination 90°, infinitely variable

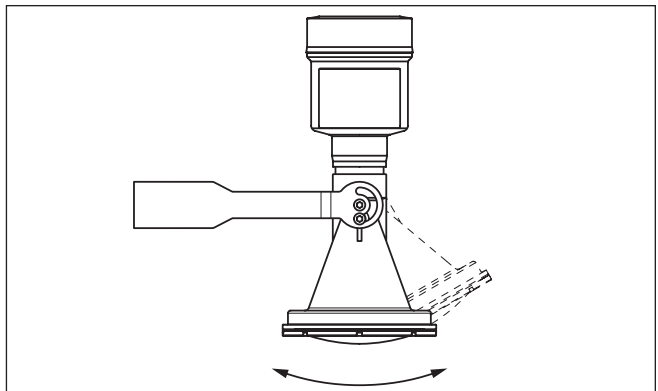

Fig. 2: Adjustment of the angle of inclination

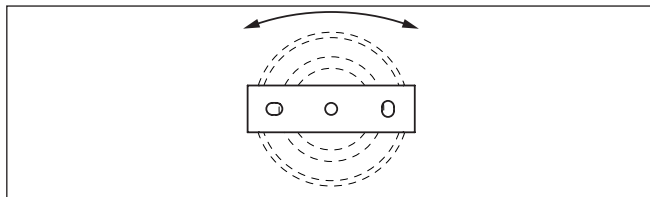

Fig. 3: Turning by fastening in the centre

Polarisation

2.2 Mounting instructions

Radar sensors for level measurement emit electromagnetic waves. The polarization is the direction of the electrical component of these waves.

The polarization direction is marked by a nose on the housing, see following drawing:

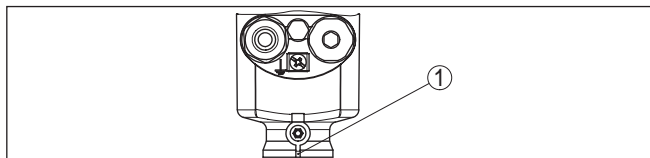

Fig. 4: Position of the polarisation

1 Nose for marking the direction of polarisation



Note:

When the housing is rotated, the direction of polarization changes and hence the influence of the false echo on the measured value. Please keep this in mind when mounting or making changes later.

Installation position

Mount the sensor at least 200 mm (7.874 in) away from the vessel wall.

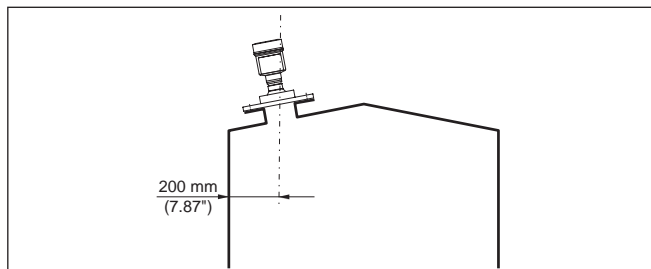

Fig. 5: Mounting the radar sensor on the vessel top

If you cannot maintain this distance, you should carry out a false signal suppression during setup. This applies particularly if buildup on the vessel wall is expected. In such cases, we recommend repeating the false signal suppression at a later date with existing buildup.

3 Connecting to power supply

3.1 Connecting

Connection technology

The voltage supply and signal output are connected via the spring-loaded terminals in the housing.

Connection to the display and adjustment module or to the interface adapter is carried out via contact pins in the housing.



Information:

The terminal block is pluggable and can be removed from the electronics. To do this, lift the terminal block with a small screwdriver and pull it out. When reinserting the terminal block, you should hear it snap in.

Connection procedure

Proceed as follows:

1. Unscrew the housing lid
2. If a display and adjustment module is installed, remove it by turning it slightly to the left
3. Loosen compression nut of the cable gland and remove blind plug
4. Remove approx. 10 cm (4 in) of the cable mantle, strip approx. 1 cm (0.4 in) of insulation from the ends of the individual wires
5. Insert the cable into the sensor through the cable entry



Fig. 6: Connection steps 5 and 6

6. Insert the wire ends into the terminals according to the wiring plan



Information:

Solid cores as well as flexible cores with wire end sleeves are inserted directly into the terminal openings. In case of flexible cores without end sleeves, press the terminal from above with a small screwdriver, the terminal opening is then free. When the screwdriver is released, the terminal closes again.

You can find further information on the max. wire cross-section under "*Technical data - Electromechanical data*".

7. Check the hold of the wires in the terminals by lightly pulling on them
8. Connect the screen to the internal ground terminal, connect the external ground terminal to potential equalisation

9. Tighten the compression nut of the cable entry gland. The seal ring must completely encircle the cable
 10. Reinsert the display and adjustment module, if one was installed
 11. Screw the housing lid back on
- The electrical connection is finished.

3.2 Wiring plan, single chamber housing



The following illustration applies to the non-Ex as well as to the Ex-ia version.

Electronics and connection compartment

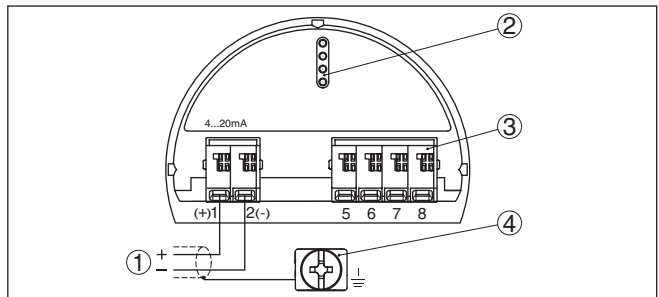

Fig. 7: Electronics and connection compartment - single chamber housing

- 1 Voltage supply, signal output
- 2 For display and adjustment module or interface adapter
- 3 For external display and adjustment unit
- 4 Ground terminal for connection of the cable screening

4 Set up with the display and adjustment module

4.1 Insert display and adjustment module

The display and adjustment module can be inserted into the sensor and removed again at any time. You can choose any one of four different positions - each displaced by 90°. It is not necessary to interrupt the power supply.

Proceed as follows:

1. Unscrew the housing lid
2. Place the display and adjustment module on the electronics in the desired position and turn it to the right until it snaps in.
3. Screw housing lid with inspection window tightly back on

Disassembly is carried out in reverse order.

The display and adjustment module is powered by the sensor, an additional connection is not necessary.



Fig. 8: Insertion of the display and adjustment module with single chamber housing



Note:

If you intend to retrofit the instrument with a display and adjustment module for continuous measured value indication, a higher lid with an inspection glass is required.

4.2 Parameter adjustment - Quick setup

To quickly and easily adapt the sensor to the application, select the menu item "Quick setup" in the start graphic on the display and adjustment module.



Carry out the following steps with the [->] key in the below sequence. You can find "Extended adjustment" in the next sub-chapter.

1. Measurement loop name

In the first menu item you assign a suitable measurement loop name. Permitted are names with max. 19 characters.

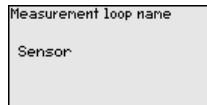

2. Medium

In this menu item you select the type of bulk solid. The selection comprises different granulate sizes.

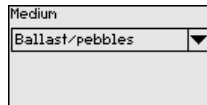

3. Application/Vessel bottom

In this menu item you specify the application and the form of the vessel bottom.

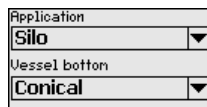

4. Vessel height/Measuring range

In this menu item you enter the height of the vessel and hence the active measuring range.



5. Max. adjustment

In this menu item you carry out the max. adjustment.

Enter the measuring distance for 100 % filling.

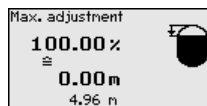

6. Min. adjustment

In this menu item you carry out the min. adjustment.

Enter the measuring distance for 0 % filling.

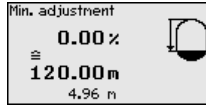

7. Termination

"Quick setup terminated successfully" is briefly displayed. The echo curve of the setup is stored automatically.

The quick setup is finished.

The return to the measured value indication is carried out through the [->] or [ESC] keys or automatically after 3 s

4.3 Parameter adjustment - Extended adjustment

Main menu

The main menu is divided into five sections with the following functions:

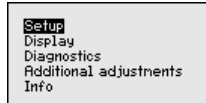

Setup: Settings, e.g., for measurement loop name, units, application, adjustment, signal output

Display: Settings, e.g., for language, measured value display, lighting

Diagnostics: Information, for example, on device status, peak value, simulation, echo curve

Additional adjustments: Date/Time, reset, copy function, scaling, current output, false signal suppression, linearization, HART mode, special parameters

Info: Instrument name, hardware and software version, calibration date, instrument features

In the main menu item "Setup", the individual submenu items should be selected one after the other and provided with the correct parameters to ensure optimum adjustment of the measurement. The procedure is described in the following.

Setup - Adjustment

Since the radar sensor is a distance measuring instrument, the distance from the sensor to the product surface is measured. To indicate the actual level, an allocation of the measured distance to the percentage height must be carried out.

To perform the adjustment, enter the distance with full and empty vessel, see the following example:

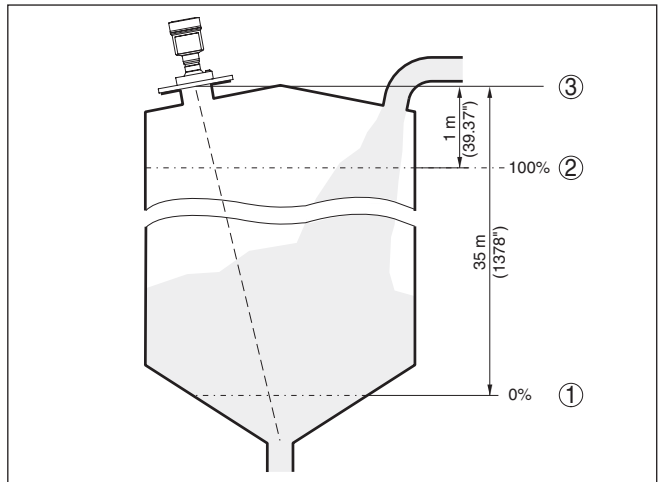

Fig. 9: Parameterisation example, Min./max. adjustment

- 1 Min. level = max. measuring distance
- 2 Max. level = min. measuring distance
- 3 Reference plane

If these values are not known, an adjustment with the distances of e.g. 10 % and 90 % is possible. Starting point for these distance specifications is always the sealing surface of the thread or flange. You can find specifications on the reference plane in chapter "Technical data". The actual level is calculated on the basis of these settings.

The actual product level during this adjustment is not important, because the min./max. adjustment is always carried out without changing the product level. These settings can be made ahead of time without the instrument having to be installed.

Diagnostics - Echo curve memory

The function "Setup" allows the echo curve to be saved at the time of setup.



Information:

This is generally recommended, however, for use of the Asset Management functions it is absolutely necessary. Saving should be carried out with a very low level.

The function "Echo curve memory" allows up to ten individual echo curves to be stored, for example to detect the measurement behaviour of the sensor in different operating conditions.

With the adjustment software PACTware and the PC, the stored echo curves can be displayed with high resolution and used to recognize signal changes over time. In addition, the echo curve saved during setup can also be displayed in the echo curve window and compared with the current echo curve.

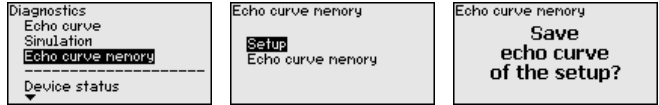

Additional settings - False signal suppression

The following circumstances cause interfering reflections and can influence the measurement:

- High mounting sockets
- Vessel internals such as struts
- Agitators
- Buildup or welded joints on vessel walls



Note:

A false signal suppression detects, marks and saves these false signals to ensure that they are ignored in the level measurement.

This should be done with the lowest possible level so that all potential interfering reflections can be detected.

Proceed as follows:

1. Select with [->] the menu item "False signal suppression" and confirm with [OK].

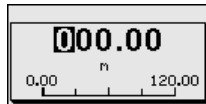
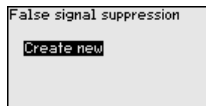
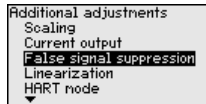

2. Confirm 3-times with [OK] and enter the actual distance from the sensor to the product surface.
3. All interfering signals in this range are detected by the sensor and stored after being confirmed with [OK].



Note:

Check the distance to the product surface, because if an incorrect (too large) value is entered, the existing level will be saved as a false signal. The level would then no longer be detectable in this area.

If a false signal suppression has already been saved in the sensor, the following menu window appears when selecting "False signal suppression":

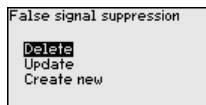

Delete: An already created false signal suppression will be completely deleted. This is useful if the saved false signal suppression no longer matches the metrological conditions in the vessel.

Extend: is used to extend an already created false signal suppression. This is useful if a false signal suppression was carried out with too high a level and not all false signals could be detected. When selecting "*Extend*", the distance to the product surface of the created false signal suppression is displayed. This value can now be changed and the false signal suppression can be extended to this range.

4.4 Menu overview

Setup

Menu item	Parameter	Default setting
Measurement loop name		Sensor
Units		Distance in m Temperature in °C
Application	Medium	Crushed stones/gravel
	Application	Silo
	Vessel bottom	Flat
	Vessel height/ Measuring range	120 m
Adjustment	Min. adjustment	120 m 0.00 %
	Max. adjustment	0,000 m(d) 100.00 %
Damping	Integration time	0.0 s
Current output	Current output - Mode	Output characteristics 4 ... 20 mA Reaction when malfunctions occur ≤ 3.6 mA
	Current output - Min./Max.	3.8 mA 20.5 mA
Lock adjustment		Released

Display

Menu item	Default setting
Menu language	Order-specific
Displayed value 1	Filling height in %
Displayed value 2	Electronics temperature in °C
Backlight	Switched on

Diagnostics

Menu item	Parameter	Default setting
Sensor status		-
Peak value indicator	Distance	-
	Measurement reliability	-
Peak values, additional	Temperature	-
Curve display	Echo curve	-
	False signal suppression	-
Simulation		Percent
Echo curve memory		Percent

Additional adjustments

Menu item	Parameter	Default setting
Date/Time		Actual date/Actual time
Reset		-
Copy instrument settings		-
Scaling	Scaling size	Volume in l
	Scaling format	0 % corresponds to 0 l 100 % corresponds to 0 l
Current output 1	Current output - Meas. variable	Lin. percent - Level
	Current output - Adjustment	0 ... 100 % correspond to 4 ... 20 mA
Current output 2	Current output - Meas. variable	Lin. percent - Level
	Current output - Adjustment	0 ... 100 % correspond to 4 ... 20 mA
False signal suppression		-
Linearisation		Linear
HART mode		Address 0
Special parameters		-

Info

Menu item	Parameter
Device name	Device name
Instrument version	Hardware and software version
Factory calibration date	Date

Menu item	Parameter
Sensor characteristics	Order-specific characteristics

5 Supplement

5.1 Technical data

Note for approved instruments

The technical data in the respective safety instructions which are included in delivery are valid for approved instruments (e.g. with Ex approval). These data can differ from the data listed herein, for example regarding the process conditions or the voltage supply.

All approval documents can be downloaded from our homepage.

Electromechanical data - version IP66/IP67 and IP66/IP68 (0.2 bar)

Options of the cable entry

- Cable entry M20 x 1.5; ½ NPT
- Cable gland M20 x 1.5; ½ NPT (cable ø see below table)
- Blind plug M20 x 1.5; ½ NPT
- Closing cap ½ NPT

Material cable gland	Material seal insert	Cable diameter				
		4.5 ... 8.5 mm	5 ... 9 mm	6 ... 12 mm	7 ... 12 mm	10 ... 14 mm
PA	NBR	-	●	●	-	●
Brass, nickel-plated	NBR	●	●	●	-	-
Stainless steel	NBR	-	●	●	-	●

Wire cross-section (spring-loaded terminals)

- Massive wire, stranded wire 0.2 ... 2.5 mm² (AWG 24 ... 14)
- Stranded wire with end sleeve 0.2 ... 1.5 mm² (AWG 24 ... 16)

Voltage supply

Operating voltage U_B 12 ... 35 V DC

Operating voltage U_B with lighting switched on 18 ... 35 V DC

Reverse voltage protection Integrated

Permissible residual ripple

- for 12 V < U_B < 18 V $\leq 0.7 V_{\text{eff}}$ (16 ... 400 Hz)
- for 18 V < U_B < 35 V $\leq 1 V_{\text{eff}}$ (16 ... 400 Hz)

Load resistor

- Calculation $(U_B - U_{\text{min}})/0.022 \text{ A}$
- Example - $U_B = 24 \text{ V DC}$ $(24 \text{ V} - 12 \text{ V})/0.022 \text{ A} = 545 \Omega$

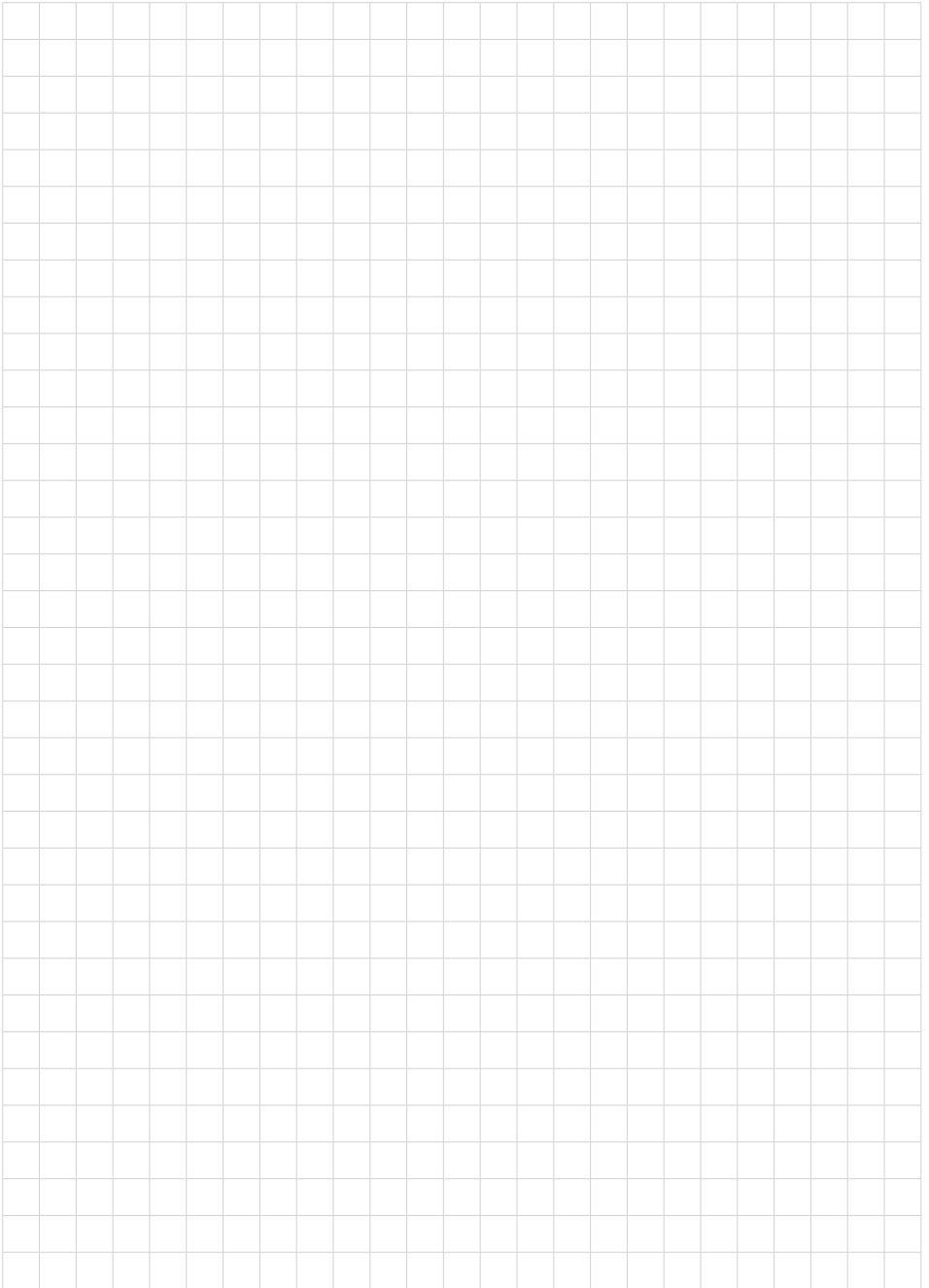

Australia
Phone +61 3 9497 4100
1800 33 48 02 – tollfree
E-Mail sales@sick.com.au

Belgium/Luxembourg
Phone +32 (0)2 466 55 66
E-Mail info@sick.be

Brasil
Phone +55 11 3215-4900
E-Mail sac@sick.com.br

Česká Republika
Phone +420 2 57 91 18 50
E-Mail sick@sick.cz

China
Phone +852-2763 6966
E-Mail ghk@sick.com.hk

Danmark
Phone +45 45 82 64 00
E-Mail sick@sick.dk

Deutschland
Phone +49 211 5301-301
E-Mail info@sick.de

España
Phone +34 93 480 31 00
E-Mail info@sick.es

France
Phone +33 1 64 62 35 00
E-Mail info@sick.fr

Great Britain
Phone +44 (0)1727 831121
E-Mail info@sick.co.uk

India
Phone +91-22-4033 8333
E-Mail info@sick-india.com

Israel
Phone +972-4-999-0590
E-Mail info@sick-sensors.com

Italia
Phone +39 02 27 43 41
E-Mail info@sick.it

Japan
Phone +81 (0)3 3358 1341
E-Mail support@sick.jp

Nederlands
Phone +31 (0)30 229 25 44
E-Mail info@sick.nl

Norge
Phone +47 67 81 50 00
E-Mail austefjord@sick.no

Österreich
Phone +43 (0)22 36 62 28 8-0
E-Mail office@sick.at

Polska
Phone +48 22 837 40 50
E-Mail info@sick.pl

Republic of Korea
Phone +82-2 786 6321/4
E-Mail kang@sickkorea.net

Republika Slovenija
Phone +386 (0)1-47 69 990
E-Mail office@sick.si

România
Phone +40 356 171 120
E-Mail office@sick.ro

Russia
Phone +7 495 775 05 34
E-Mail info@sick-automation.ru

Schweiz
Phone +41 41 619 29 39
E-Mail contact@sick.ch

Singapore
Phone +65 6744 3732
E-Mail admin@sicksgp.com.sg

Suomi
Phone +358-9-25 15 800
E-Mail sick@sick.fi

Sverige
Phone +46 10 110 10 00
E-Mail info@sick.se

Taiwan
Phone +886 2 2365-6292
E-Mail sickgrc@ms6.hinet.net

Türkiye
Phone +90 216 587 74 00
E-Mail info@sick.com.tr

USA/Canada/México
Phone +1(952) 941-6780
1800-325-7425 – tollfree

E-Mail info@sickusa.com

More representatives and
agencies in all major industrial
nations at www.sick.com

SICK
Sensor Intelligence.