

# VMS4200/5200

Track and trace system

**SICK**  
Sensor Intelligence.

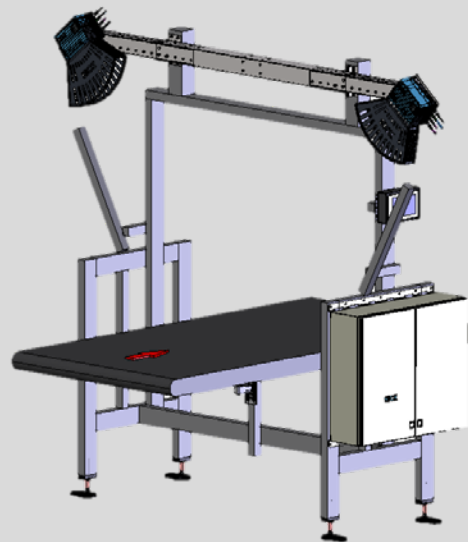

---

**Described product** VMS4200 / VMS5200

**Document no.** 8026364

**Manufacturer** SICK AG  
Erwin-Sick-Str. 1 · 79183 Waldkirch · Germany  
www.sick.com

**Legal notes** This work is protected by copyright. The associated rights are reserved by SICK AG. Reproduction of this document or parts of this document is only permissible within the limits of the legal provisions of copyright law. Any modification, abridgment, or translation of this document is prohibited without the express written permission of SICK AG.

The trademarks mentioned in this document are the property of their respective owners.

© SICK. All rights reserved

**Original documents** This document is a translation of an original document of SICK AG.

## Content

<b>1</b>	<b>About this document.....</b>	<b>6</b>
1.1	Limitation of liability.....	6
1.2	Purpose of this document.....	6
1.3	Target groups.....	6
1.4	Further information.....	7
1.5	Other relevant technical documentation/information.....	7
1.6	Document conventions.....	7
<b>2</b>	<b>For your safety.....</b>	<b>8</b>
2.1	Intended use.....	8
2.2	General safety notes.....	8
2.3	Requirements for the qualification of personnel.....	9
2.4	Sources of danger.....	9
2.5	Protective devices.....	10
2.6	Warranty.....	10
2.7	RoHS Directive.....	10
2.8	Safety conventions.....	10
2.9	Warning symbols on the system components.....	11
2.10	Mandatory symbols.....	11
<b>3</b>	<b>System description.....</b>	<b>12</b>
3.1	Scope of delivery.....	12
3.2	System components.....	13
3.2.1	LMS4x21 2D LiDAR sensors.....	15
3.2.2	Incremental encoder.....	16
3.2.3	Trigger photoelectric sensor (optional).....	17
3.2.4	Cabinet.....	18
3.2.5	Expanding the system with a reading station.....	20
3.3	Operating principle.....	21
3.3.1	Triggering the recording of measured values.....	21
3.3.2	Transport conditions.....	23
3.3.3	Recording of measured values and data processing.....	24
3.3.4	Data output.....	25
3.4	Additional functions.....	27
3.5	Nominal operating conditions.....	28
3.5.1	Fixed scale values.....	28
3.5.2	Dynamic scale value switchover.....	30
3.6	Legal for trade operation.....	33
3.6.1	Information labels.....	33
3.6.2	Security seal.....	37
3.6.3	Alibi memory and firmware.....	42
3.6.4	LFT display.....	45
3.6.5	Test instructions for market surveillance.....	48
3.7	System requirements for legal for trade operation.....	52
3.7.1	Requirements on the ambient conditions.....	52
3.7.2	Requirements on the conveying equipment.....	52
3.7.3	Mounting requirements.....	54
3.7.4	Object requirements.....	56
<b>4</b>	<b>Mounting.....</b>	<b>58</b>
4.1	Mounting 2D LiDAR sensors.....	58

- 4.1.1 Overview ..... 58
- 4.1.2 Assembling profiles of the telescopic tube ..... 59
- 4.1.3 Mounting the telescopic tube on the frame ..... 60
- 4.1.4 Fastening the 2D LiDAR sensors to the mounting plates ... 60
- 4.2 Mounting the incremental encoder ..... 61
- 4.3 Mounting the trigger photoelectric sensor ..... 61
- 4.4 Mounting the cabinet..... 62
- 5 Electrical installation ..... 63**
  - 5.1 Connection overview..... 64
  - 5.2 Connecting the voltage supply ..... 65
  - 5.3 Connection for LFT Ethernet switch (set up at the factory) ..... 66
  - 5.4 Connection of 2D LiDAR sensors ..... 67
  - 5.5 Connection for the LFT display (set up at the factory) ..... 69
  - 5.6 Connecting the incremental encoder ..... 70
  - 5.7 Connection for the photoelectric retro-reflective sensor (optional) .... 71
  - 5.8 Connecting the customer interface ..... 72
- 6 Commissioning ..... 73**
  - 6.1 Switching on the system..... 73
  - 6.2 Configuring the system with SOPAS..... 74
    - 6.2.1 Connecting the configuration PC ..... 74
    - 6.2.2 Installing SOPAS ..... 75
    - 6.2.3 Assigning IP addresses..... 76
    - 6.2.4 Opening the configuration interface ..... 82
    - 6.2.5 Logging on to device ..... 83
    - 6.2.6 Saving the parameters permanently ..... 84
- 7 Maintenance and repair ..... 85**
  - 7.1 Monitoring and cleaning work..... 86
    - 7.1.1 Control measurements..... 86
    - 7.1.2 Visual inspection..... 86
    - 7.1.3 Cleaning the 2D LiDAR sensors ..... 87
    - 7.1.4 Cleaning the deflector mirror ..... 88
    - 7.1.5 Checking the incremental encoder components ..... 89
    - 7.1.6 Cleaning the photoelectric retro-reflective sensor..... 89
    - 7.1.7 Cleaning the cabinet..... 90
  - 7.2 Replacing components..... 91
    - 7.2.1 Replacing the 2D LiDAR sensor ..... 91
    - 7.2.2 Replacing the deflector mirror ..... 93
    - 7.2.3 Replacing the incremental encoder components..... 94
    - 7.2.4 Replacing the photoelectric retro-reflective sensor..... 95
    - 7.2.5 Replacing the battery in the SIM2000-2 Prime controller ... 96
- 8 Fault diagnosis ..... 97**
  - 8.1 Fault indications of the components ..... 97
    - 8.1.1 Fault indication on the LMS4x21..... 97
    - 8.1.2 SIM2000 fault indication ..... 98
    - 8.1.3 Fault indication on the trigger photoelectric sensor ..... 99
  - 8.2 Checks on the SIM2000..... 100
    - 8.2.1 Checking the triggering..... 100
    - 8.2.2 Checking the incremental encoder..... 101
    - 8.2.3 Checking the CAN cabling ..... 102
  - 8.3 Detailed fault analysis ..... 103

<b>9</b>	<b>Technical data</b> .....	<b>104</b>
9.1	Data sheet .....	104
9.2	Dimensional drawings.....	106
9.2.1	Dimensional drawings for the 2D LiDAR sensor .....	106
9.2.2	Dimensional drawings for the cabinet.....	107
9.3	Compliance with EU directives .....	108
<b>10</b>	<b>Disposal</b> .....	<b>109</b>

## 1 About this document

These supplementary operating instructions on the VMS4200 / VMS5200 multi-dimensional measurement system:

- Contain information that is required during the life cycle of the system.
- Must be available to all those who work with the system.
- Should be read through carefully, and the contents fully understood before working with the system.

### 1.1 Limitation of liability

Applicable standards and regulations, the latest technological developments, and our many years of knowledge and experience have all been taken into account when assembling the data and information contained in this document.

The manufacturer accepts no liability for damage caused by:

- Failure to observe this document.
- Non-compliance with notes and regulations.
- Unauthorized mounting and installation.
- Unauthorized technical and other changes.
- Use of unauthorized spare parts, wear and tear parts, and accessories.
- Unauthorized changes, adjustments, and/or manipulations of software.
- Failure to perform and document regular maintenance work.

The actual scope of delivery may differ from the features and illustrations shown here where special variants are involved, if optional extras have been ordered, or as a result of the latest technical changes.

### 1.2 Purpose of this document

This document describes the VMS4200 / VMS5200 multi-dimensional measurement system with an SIM200-2 Prime controller.



The supplementary operating instructions for the VMS4200/5200 MID with a SIM2000-2 Prime Controller are only valid in conjunction with the main operating instructions for the VMS4200/VMS5200 (*Multicontroller*) (8022964-1716 DE / 8022965-1716 EN).

Unless otherwise specified in this document, the information in the main operating instructions for the VMS4200/5200 (*Multicontroller*) will apply.

---

### 1.3 Target groups

This document is intended for qualified persons who operate the VMS4200 / VMS5200.

## 1.4 Further information

### Special local conditions

The local laws, regulations, technical rules and internal company operating instructions at the installation location must be observed.

### Storage of documents

This document and other relevant technical documentation/information:

- Must be kept available for reference.
- Must be handed over to new system operators/new specialist personnel.

## 1.5 Other relevant technical documentation/information

- Technical system documentation
  - E297247 A (EPLAN)
  - Technical data
  - Connection diagram
  - Terminal diagram
- Operating instructions for the following system components:

Component	Manufacturer
LMS4000 2D LiDAR sensor operating instructions	SICK
SIM2000-2 Prime Sensor Integration Machine operating instructions	SICK
Operating instructions for TTC100-2 track and trace cabinet in combination with SIM2000-2 Prime	SICK

## 1.6 Document conventions

- ▶ Instructions
- ✓ Result of action
- All measurement units used in this document are metric.
- Subject to change without notice.
- Figures may differ from the actual design.

### 2 For your safety

#### 2.1 Intended use

The VMS4200/5200 multi-dimensional measurement system is used to measure cubic and irregularly-shaped objects on flat conveying systems in industrial environments.

The objects to be measured must be dimensionally stable, opaque, and non-reflective.

The two LMS4x21 2D LiDAR sensors are mounted horizontally above the conveying technology and typically rotated at an angle of 45°.

The VMS4200/5200 determines the length, width and height. These dimensional values can be used to calculate the volume of the smallest rectangular box that fully encloses the object.

The measurement results can be transferred to the customer network via the data interface of the SIM2000-2 Prime controller.

The VMS5200 multi-dimensional measurement system can be verified as legal for trade and, after a successful MID conformity assessment, used for billing purposes.

**NOTE!** Intended use also includes observance of these supplementary operating instructions, in particular the safety notes and repair and maintenance requirements as well as proper installation, in particular for billing operation.

#### 2.2 General safety notes

- ▶ Please read this document through carefully and observe all the safety notes and information before working on the multi-dimensional measurement system.
- ▶ Only qualified persons from the relevant departments are permitted to work on the multi-dimensional measurement system.
- ▶ Follow operating processes.
- ▶ Follow local regulations.
- ▶ Follow all local regulations relating to working with electrical components.
- Only authorized persons are permitted access to the multi-dimensional measurement system.

##### **System damage/transport damage**

Damage to the individual components can lead to malfunctions of the system as a whole.

- ▶ Do not ignore any damage caused to system components during transport.
- ▶ In case of damage, contact SICK Service.



## 2.3 Requirements for the qualification of personnel

Only qualified persons with the relevant technical expertise are permitted to work on the system.

- Qualified persons have the specialist training, skills, and experience, as well as knowledge of the relevant regulations and standards, to be able to perform work assigned to them and to identify and avoid any potential dangers independently.
- Electricians have the professional training, skills and experience, and knowledge of the relevant standards and provisions to work on electrical systems and to detect and avoid any potential dangers independently.

## 2.4 Sources of danger

### Optical radiation: Laser class 2

The 2D LiDAR sensors of the VMS4200/5200 use a class 2 laser.

The human eye is not at risk when briefly exposed to the radiation for up to 0.25 seconds. Exposure to the laser beam for longer periods of time may cause damage to the retina. The laser radiation is harmless to human skin.

- ▶ Never look directly into the laser beam.
- ▶ Never point the laser beam at people's eyes.
- ▶ During commissioning or maintenance work, suitable eye protection must be worn.
- ▶ Avoid laser beam reflection caused by reflective surfaces. In particular during mounting and alignment work.
- ▶ Do not open the housing.
- ▶ Current national regulations regarding laser protection must be observed.

### Electrical voltage

Touching live devices, which may still be energized, can lead to death, burns or electrical shock.

- ▶ Electrical work may only be performed on the system by qualified specialist personnel.
- ▶ Before working on electrical components, observe the five safety rules:
  - ▶ Disconnect.
  - ▶ Secure against being switched back on.
  - ▶ Ensure that there is no voltage.
  - ▶ Ground and short-circuit.
  - ▶ Cover or enclose live parts in the vicinity.

### Suspended loads

- ▶ Never enter the area under suspended loads.
- ▶ Pay close attention when lifting loads.
- ▶ Comply with lifting instructions to prevent injuries and accidents.
- ▶ Use suitable, undamaged lifting tools.
- ▶ Wear personal protective equipment (safety helmet, safety shoes).

### 2.5 Protective devices

The multi-dimensional measurement system is designed in a way that allows for safe operation. Protective devices reduce potential risks to the maximum possible extent.

- Laser protective cover for the LMS4x21 2D LiDAR sensor

### 2.6 Warranty

No warranty claims will be accepted if:

- ▶ The safety notes and measures in this document are not observed.
- ▶ Parts or components of the multi-dimensional measurement system have been installed, mounted or modified without authorization.
- ▶ The multi-dimensional measurement system has been altered or modified.
- ▶ The software has been modified, customized, and/or tampered with without authorization.

### 2.7 RoHS Directive

This product has been designed for specific applications in large industrial systems according to Article 2 (4) e, RoHS 2011/65 / EU, and must therefore only be used in such systems.

The product is neither suitable nor approved for use outside of these systems. SICK therefore cannot provide any warranty or accept any liability whatsoever for such use.

### 2.8 Safety conventions

The warnings used in this manual have the following meanings:

 **DANGER**

Identifies an imminent danger, which will lead to death or serious injuries if not prevented.

 **WARNING**

Identifies a situation presenting danger, which will lead to death or serious injuries if not prevented.

 **CAUTION**





Identifies a possibly hazardous situation which may lead to minor or moderate bodily injuries or material damage if not prevented.

**NOTE**





Important information and useful notes.

## 2.9 Warning symbols on the system components

Warning labels must not be removed or covered up. If labels are missing, these must be affixed. Damaged labels must be replaced.

Symbol	Meaning
	Hazardous point warning
	Hazardous electrical voltage warning
	Laser beam warning
	Suspended load warning

## 2.10 Mandatory symbols

Symbol	Meaning
	Read document
	Use head protection
	Use foot protection
	Disconnect before maintenance or repairs

### 3 System description

#### 3.1 Scope of delivery

**NOTE!**

- ▶ After delivery, inspect the system for transport damage and report any such damage immediately.
- ▶ Check that the delivery includes all components listed on the delivery note.

**System components**

- 2 LMS4421R-16000 2D LiDAR sensors with laser protective cover for the VMS4200 or 2 LMS4521R-16000 2D LiDAR sensors with laser protective cover for the VMS5200
- 1 LFT display - VMS5200 only
- 1 TTC100-2 cabinet with a SIM2000-2 Prime controller, power supply unit modules and LFT Ethernet switch
- 1 incremental encoder with mounting kit (e.g., DFV60, DBS36)
- 1 modular mounting set
- 2 beam blockers
- Connecting cables

**Optional**

- 1 photoelectric retro-reflective sensor for triggered systems (e.g., RAY26)
- 1 deflector mirror for reducing the mounting height of the 2D LiDAR sensors

**NOTE**

**These operating instructions use the product name of the controller: SIM2000-Prime. The device name is SIM2000ST-E.**

## 3.2 System components

### Devices

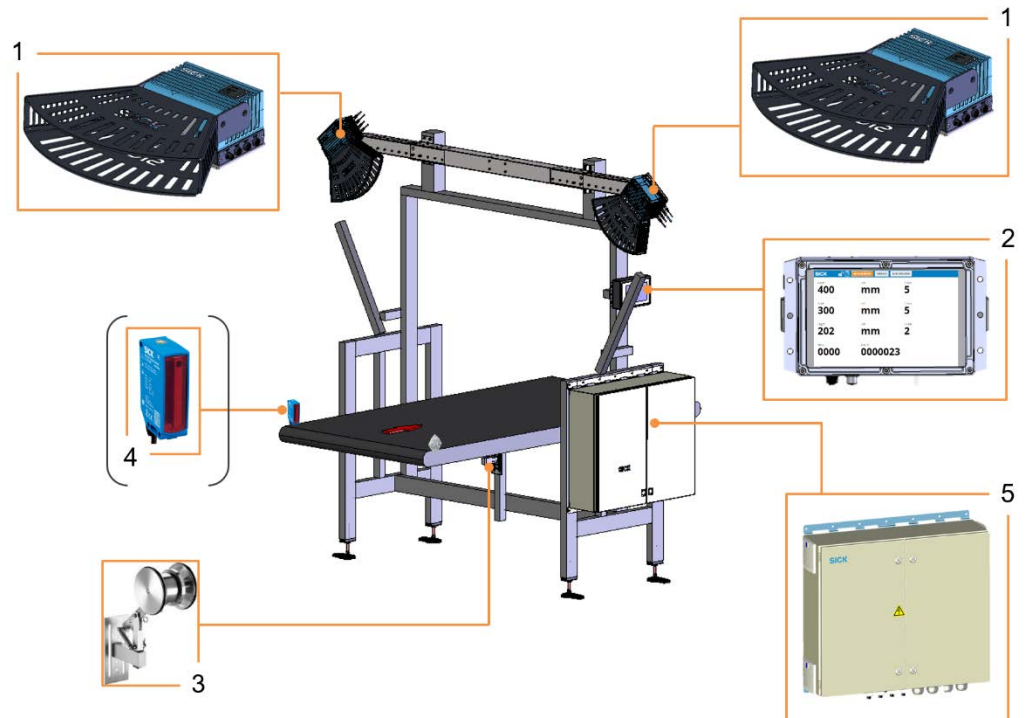

Fig. 1: Components of the VMS4200/5200

#### Legend

- |   |   |
|---|---|
| 1 | LMS4x21 2D LiDAR sensors with laser protective cover                      |
| 2 | LFT display - VMS5200 only  |
| 3 | Incremental encoder (e.g., DFV60)   |
| 4 | Photoelectric retro-reflective sensor for triggered systems (e.g., RAY26) |
| 5 | Cabinet with a SIM2000-2 Prime controller and power supply units          |

### Mounting

- Mount the system components according to the technical drawing on a frame provided by the customer.
- Additional glare protection on the frame (beam blocker) prevents objects located outside of the measuring range from being included in the calculation of measured values.

### 3 SYSTEM DESCRIPTION

#### System variant with deflector mirror

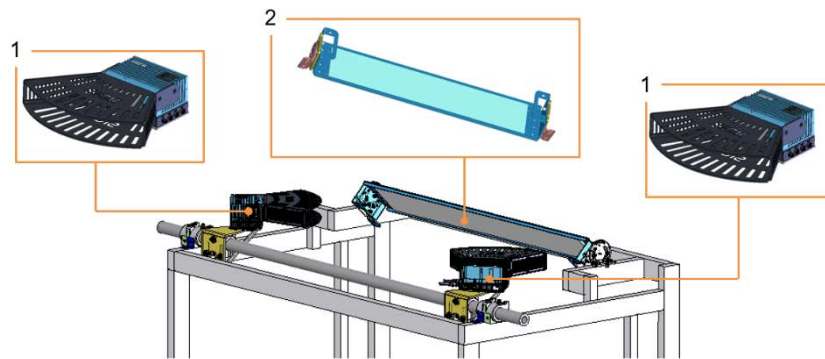

Fig. 2: VMS4200/5200 with deflector mirror

---

#### Legend

- |   |  |
|---|--|
| 1 | LMS4x21 2D LiDAR sensors with laser protective cover |
| 2 | Deflector mirror                                     |
- 

- If the 2D LiDAR sensors cannot be mounted at the prescribed minimum height, the measurement points can be captured by a deflector mirror mounted parallel to the 2D LiDAR sensors.
- The resulting extension of the light path means that you can save space when mounting the 2D LiDAR sensor on the conveying equipment.
- The deflection via the mirror is free of loss thanks to its special surface metallization, as this rules out light refraction.
- The upper figure shows a visualization example of the arrangement of the 2D LiDAR sensors and the deflector mirror over the transport belt.
- The remaining system setup and operating principle of the VMS4200/5200 satisfy the requirements for the relevant type approval certificate.

**NOTE!** These supplementary operating instructions describe system variant without deflector mirror.

## 3.2.1 LMS4x21 2D LiDAR sensors

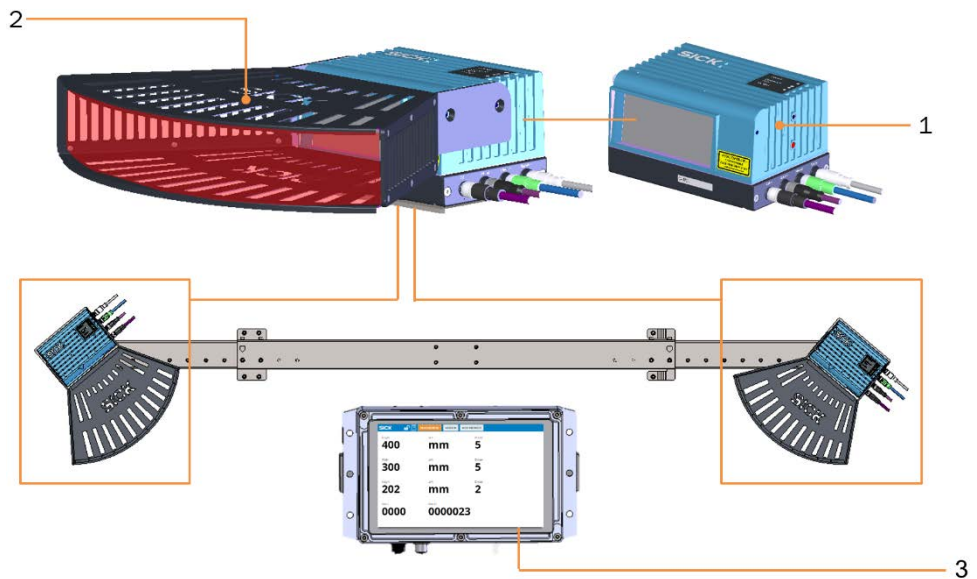

Fig. 3: LMS4x21 2D LiDAR sensors with LFT display - VMS5200 only

---

 Legend

- 1 LMS4x21 2D LiDAR sensor
  - 2 Laser protective cover
  - 3 LFT display for VMS5200 measurement systems approved for billing applications
- 

**Features**

- Consists of two LMS4x21 2D LiDAR sensors with laser protective covers that are mounted on a profile and located on the right and left above the conveying equipment.
- The LMS4x21 2D LiDAR sensors are configured as master and slave.

**Function**

- Used to calculate the relevant object dimensions by detecting the object on flat conveying systems without making contact.

**LFT display**

- VMS5200 measurement systems operated in legal-for-trade applications also have a separate LFT display to show the measurement results, status information, firmware version, and logbook (version history).

### 3 SYSTEM DESCRIPTION

---

#### 3.2.2 Incremental encoder

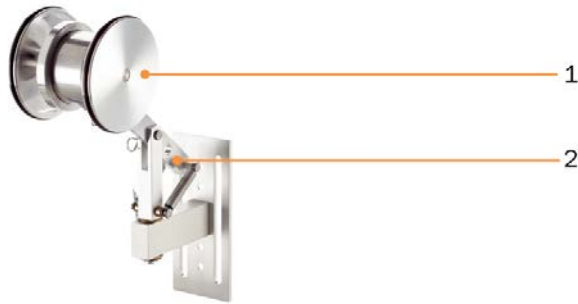

Fig. 4: DFV60 incremental encoder

---

#### Legend

- |   |                            |
|---|----------------------------|
| 1 | Measuring wheel            |
| 2 | Spring-loaded mounting arm |
- 

#### Properties

- Measuring wheel system mounted under the conveyor belt.
- Large spring travel and pivot range of the spring arm compensates for unevenness on the measurement surface.

#### Function

- Measurement of linear movements.
- Detection of position and speed directly on the running surface of the conveyor belt using a precision measuring wheel.



### 3.2.3 Trigger photoelectric sensor (optional)

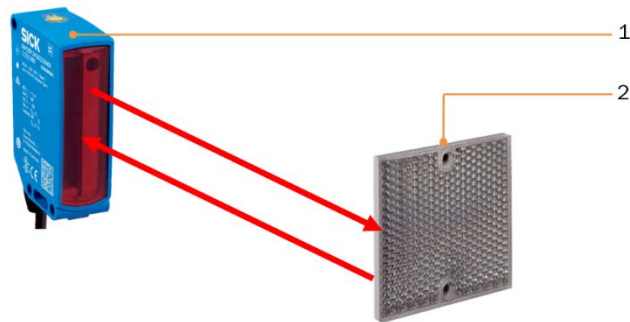

Fig. 5: Trigger photoelectric sensor and reflector

---

#### Legend

- |   |   |
|---|---|
| 1 | Photoelectric retro-reflective sensor (e.g., RAY26) |
| 2 | Reflector   |
- 

#### Features

- The light band emitted by the object detection photoelectric sensor is reflected back by a reflector.
- Sender and receiver are arranged parallel to one another in the housing.
- Mounted in front of the measuring field.

#### Function

- Supplies the trigger signal in systems with triggered measurement.
- The trigger signal activates the sensors and opens the internal reading gate.
- The photoelectric sensor trigger is available as an option.

### 3 SYSTEM DESCRIPTION

#### 3.2.4 Cabinet

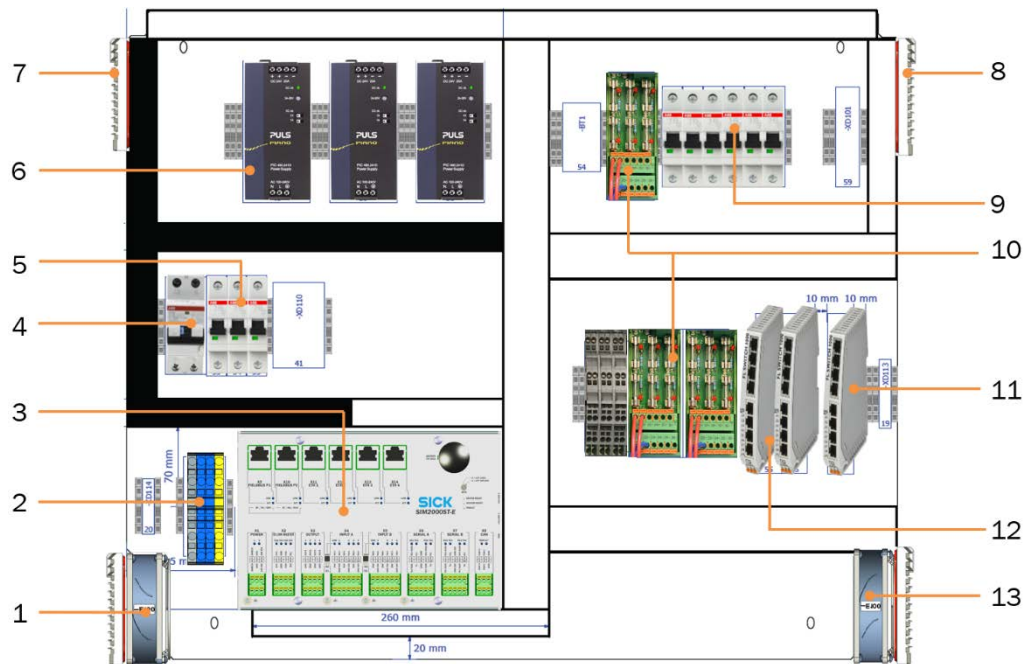

Fig. 6: Cabinet of the VMS4200/5200

#### Legend

- 1 Air inlet for cooling (with filter mat and cooler)
- 2 Terminals for voltage supply IN (100–264 V AC / 50–60 Hz)
- 3 SIM2000-2 Prime controller with alibi memory
- 4 RCD (residual current device) for protective contact plug
- 5 Circuit breaker
- 6 Power supply unit for supplying voltage to the SIM2000-2 Prime controller and 2D LiDAR sensors
- 7 Air outlet for cooling (with filter mat)
- 8 Air outlet for cooling (with filter mat)
- 9 Circuit breaker
- 10 LFT terminals (24 V DC) and fuse module OUT
- 11 LFT Ethernet switch for connecting the LFT components
- 12 Ethernet switches for connecting additional sensors
- 13 Air inlet for cooling (with filter mat and fan)

#### Properties

- Contains power supply units for the central voltage supply to system components.
- Contains the SIM2000-2 Prime controller, the central processing unit, and the control unit of the VMS4200/5200.
- The SIM2000-2 Prime controller contains the legally relevant memory (alibi memory).

**Function**

- Central voltage supply for all system components.
- Coordinates all connected sensors and processes the measured values received.
- The SIM2000-2 Prime controller receives the measuring points from the LiDAR sensors and uses the 2D sections to calculate a three-dimensional model.
- It determines the box volume and dimensional values based on the calculated 3D model.
- The data is sent to the higher-level customer system via the SIM200-2 Prime controller in a host telegram with a defined format.

**NOTE!** In the case of the VMS5200, the measurement results are saved in the SIM2000-2 Prime controller alibi memory, which is required for legal-for-trade verification.

### 3 SYSTEM DESCRIPTION

#### 3.2.5 Expanding the system with a reading station

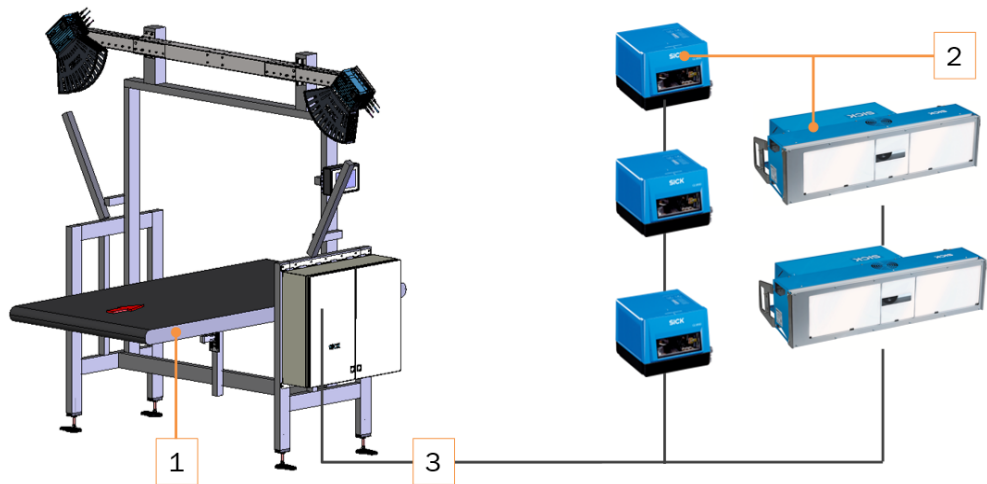

Fig.7: Expanding the system with a reading station

#### Legend

- |   |                 |
|---|-----------------|
| 1 | VMS4200/5200    |
| 2 | Reading systems |
| 3 | CAN bus         |

#### Properties

- Expansion of the VMS4200/5200 multi-dimensional measurement system with a reading station.
- Depending on the application, this station can consist of scanners, cameras, application-specific trigger elements and/or a combination of these components in any desired arrangement.

#### Function

- Allows automatic object identification using bar codes.
- Streamlines process automation.

**NOTE!** The multi-dimensional measurement system can also supply the focus information for the connected camera systems.

#### Connection

- The devices are connected to the multi-dimensional measurement system via the CAN bus of the SIM2000-2 Prime controller.
- The SIM2000-2 Prime controller links the acquired identification data with the dimension values calculated by the VMS4200/5200.
- Identification data and dimension values are output together to the higher-level system.

### 3.3 Operating principle

#### 3.3.1 Triggering the recording of measured values

##### Free-running mode

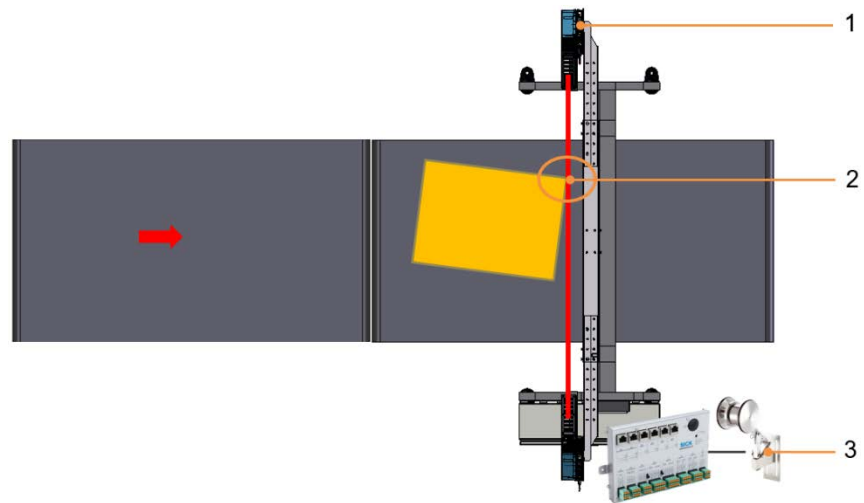

Fig. 8: Free-running mode

---

#### Legend

- |   |                              |
|---|------------------------------|
| 1 | Measurement site             |
| 2 | Scanning line = trigger line |
| 3 | Incremental encoder          |
- 

- The multi-dimensional volume measurement system detects the objects to be measured on its own.
- The measurement starts when an object enters the scanning line of the 2D LiDAR sensors.
- Measurement ends when the object leaves the scanning line.

#### Triggered mode

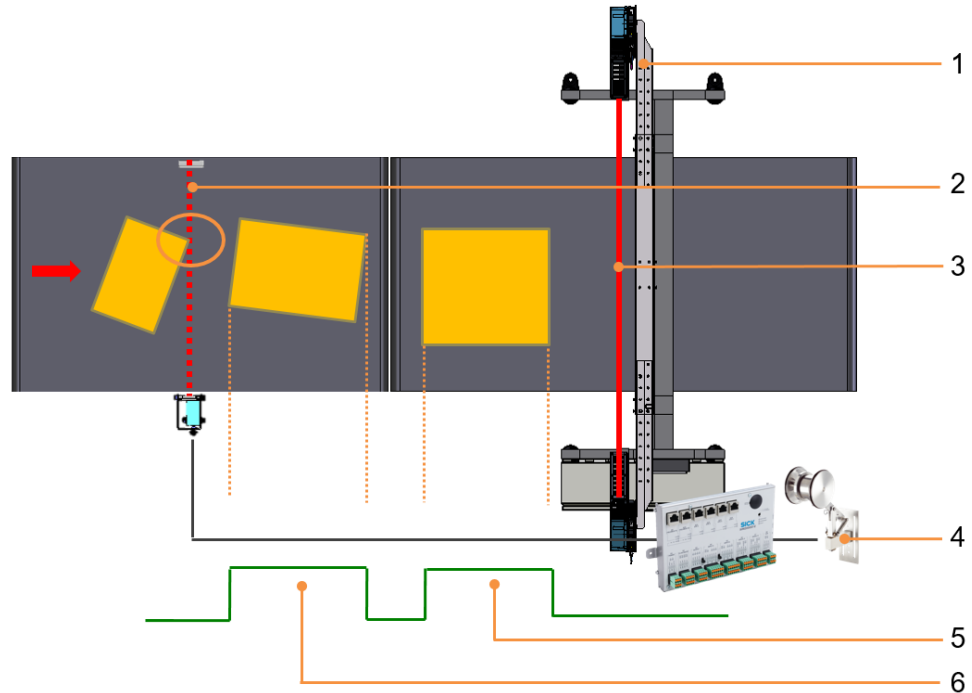

Fig. 9: Triggered mode

#### Legend

- |   |   |
|---|---|
| 1 | Measurement site  |
| 2 | Trigger line of the photoelectric retro-reflective sensor |
| 3 | Scanning line of the 2D LiDAR sensor                      |
| 4 | Incremental encoder                                       |
| 5 | Reading gate for triggered object 2                       |
| 6 | Reading gate for triggered object 1                       |

- The object is detected by a trigger signal.
- The trigger signal can be triggered by the entry of the object into the path of a photoelectric retro-reflective sensor or via a customer-controlled digital signal.
- The trigger signal activates the 2D LiDAR sensors and opens the internal reading gate.
- The reading gate determines the start and end of the measuring process. It corresponds to the trigger length in the conveying direction.
- The measuring process lasts for as long as the reading gate is open, regardless of whether the object is entering or leaving the scanning line.

#### Object tracking

- In both operating modes, the incremental encoder supplies information for defining the exact position of the object on the conveying equipment.
- This information is required to calculate the length information and for correct assignment of the measurement results to the object.

3.3.2 Transport conditions

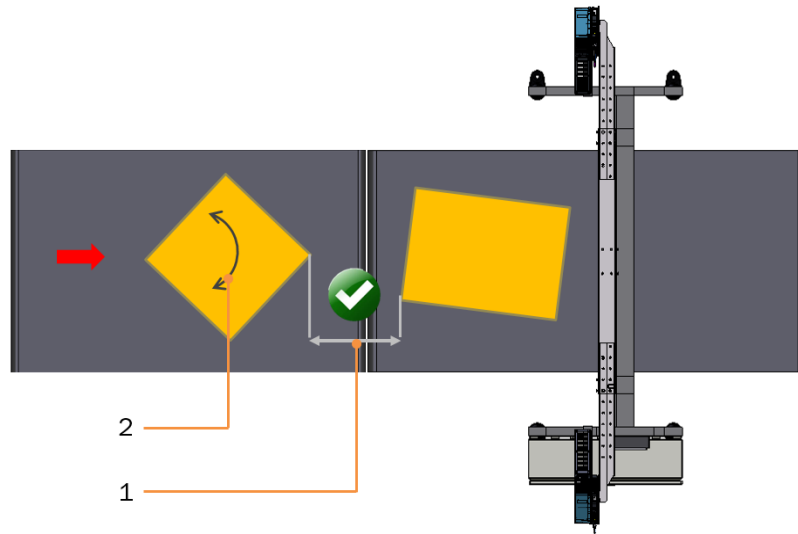

Fig. 10: Object conveyance with minimum distance and rotation angle

Legend

- 1 Minimum distance between objects
- 2 Rotation of the objects on the conveyor belt

Transport conditions

- Objects must pass through the measuring station separately and at a defined **minimum distance** of 50 mm.
- The objects may be placed on the conveyor belt in any direction.

Not allowed

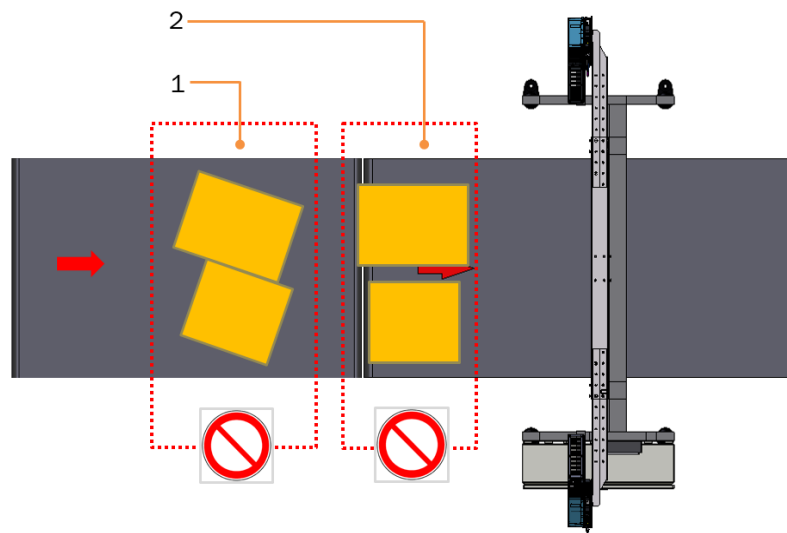

Fig. 11: Unable to measure objects that are touching or lying side by side

Legend

- 1 The objects must not be located side-by-side\*.
- 2 The objects must not be touching\*.

Otherwise the track and trace system will deliver invalid measurement results.

### 3 SYSTEM DESCRIPTION

#### 3.3.3 Recording of measured values and data processing

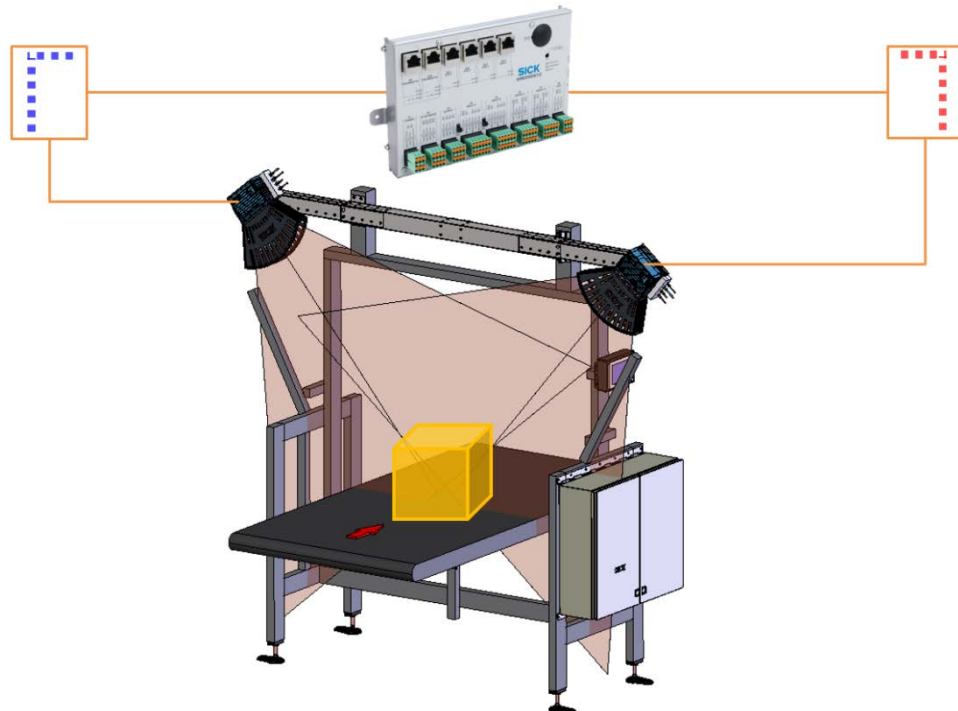

Fig. 12: Measuring point determination of the VMS4200/5200

- The calculation of measurement values begins as soon as an object is transported past the 2D LiDAR sensors on the equipment below.
- The two 2D LiDAR sensors span a two-dimensional measuring range and perform a non-contact scan of the surface of the object on the cross belt conveying equipment.
- They cyclically transmit the detected measuring points to the SIM2000-2 Prime controller for further processing.

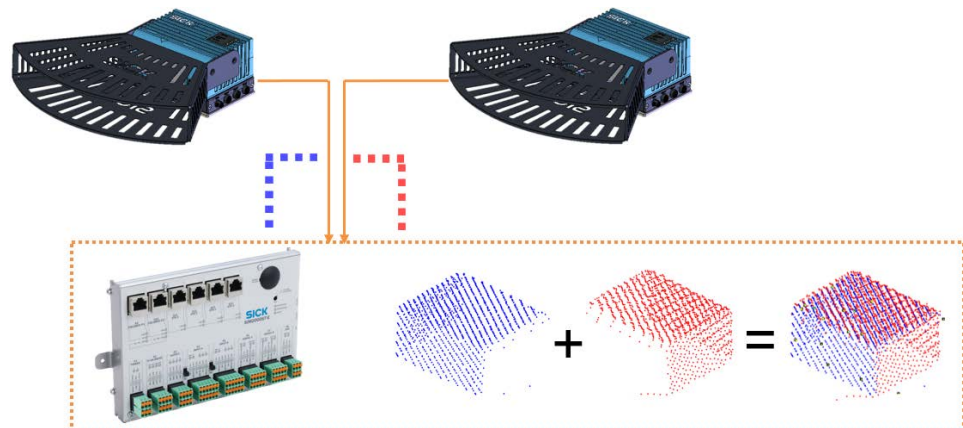

Fig. 13: Building 3D model in the SIM2000-2 Prime controller

- When the detected conveyor belt speed and the specific position of the object on the belt are factored in, a spatial model is created.
- The SIM200-2 Prime controller calculates the length, width and height of the smallest rectangular box that fully encloses the object. These dimension values can be used to calculate the volume of the rectangle.



- In billing-related operation, the measurement results of the VMS5200 are shown on a separate LFT display.

### 3.3.4 Data output

#### VMS4200 data output

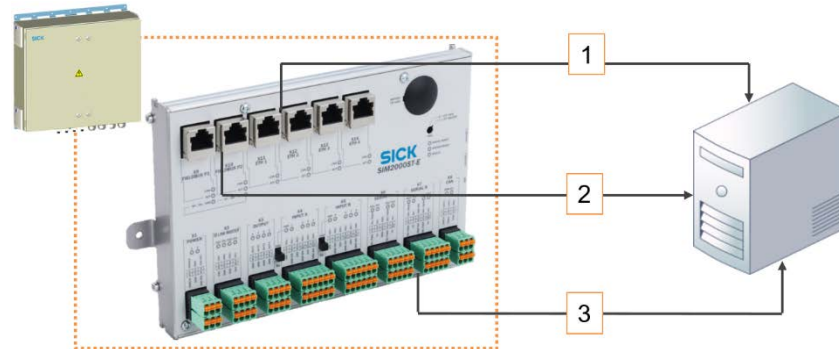

Fig. 14: Data output of the VMS4200

#### Legend

- |   |                                |
|---|--------------------------------|
| 1 | Data output via Ethernet       |
| 2 | Data output via fieldbus       |
| 3 | Data output via RS-232 / RS422 |

- The SIM2000-2 Prime controller assigns the calculated measurement results to the respective object.
- The measurement results are issued to a higher-level system.
- The data is issued via a host telegram coordinated by the customer.
- The calculated 3D point cloud of the calculated model can also be optionally output here.

### 3 SYSTEM DESCRIPTION

#### VMS5200 data output

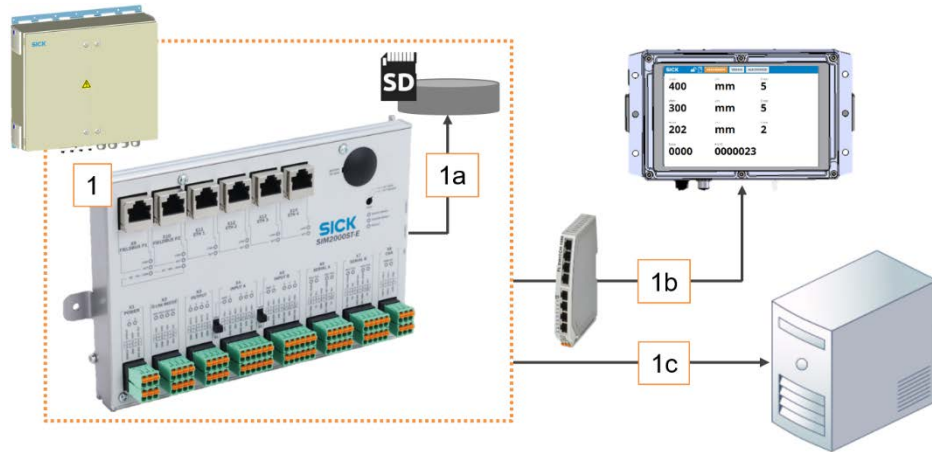

Fig. 15: Data output of the VMS5200

#### Legend

- 1 SIM2000-2 Prime controller
- 1a Saving of measurement results in alibi memory
- 1b Display of measurement results on LFT display
- 1c Data output via Ethernet, fieldbus, RS-232 / RS422

- During billing-related operation of the VMS5200, before the data is output the measurement results are saved in the SIM2000-2 Prime controller alibi memory, which is required for legal-for-trade verification.
- The measurement results are also displayed on the LFT display.

#### Configuring output times

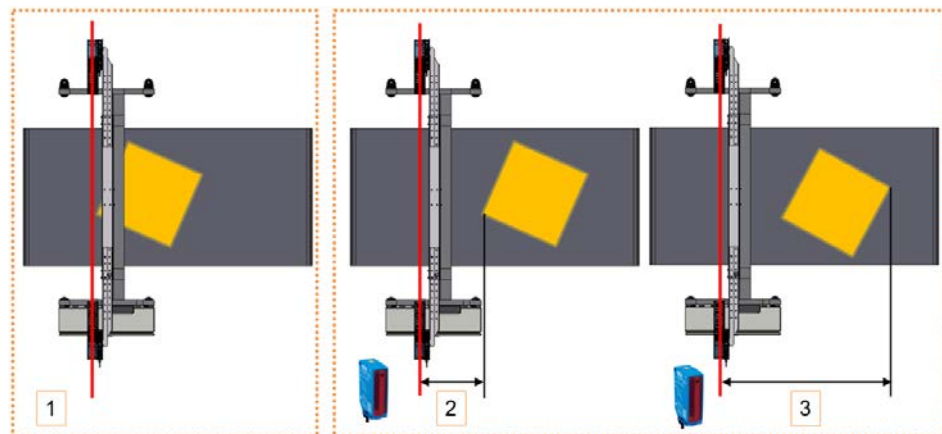

Fig. 16: Configuring the time of the data output

#### Legend

- 1 Free-running operating mode: issue as soon as possible after leaving the scanning line.
- 2 Triggered operating mode: after a defined distance from X position in relation to the rear edge of an object.
- 3 Triggered operating mode: after a defined distance from X position in relation to the leading edge of an object.

- The output time is configured using SOPAS.
- Issue depends on the triggering mode selected.

### 3.4 Additional functions

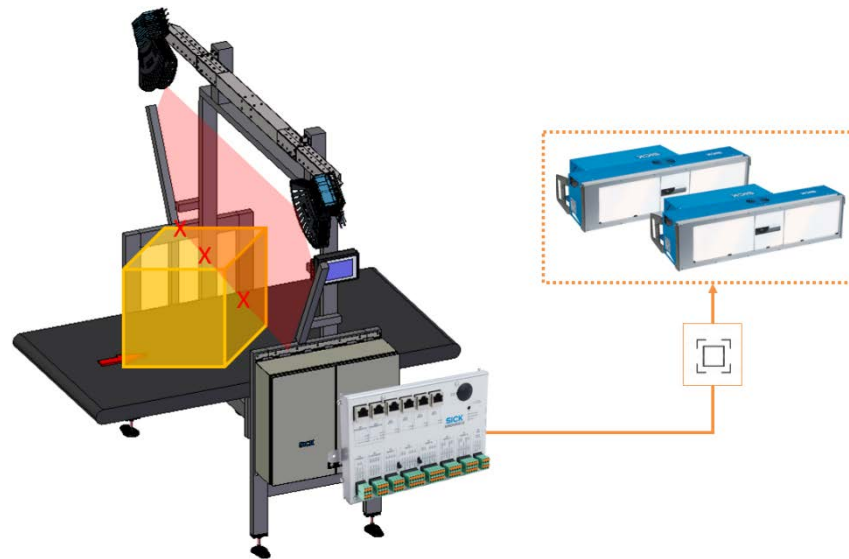

Fig. 17: Contour data as focus data for connected reading systems

- If the VMS4200/5200 multi-dimensional measurement system is operated as part of a complete system with a reading station (see section [3.2.5 Expanding the system with a reading station](#)), the contour data can be used as the basis for dynamic camera focusing.
- For this purpose, the controller supplies continuous information about the distance of the 2D LiDAR sensor to the object surface via the CAN bus.

### 3 SYSTEM DESCRIPTION

#### 3.5 Nominal operating conditions

The VMS4200/5200 multi-dimensional measurement system can determine the length, width, and height of the smallest rectangular box that fully encloses cubic and irregularly shaped measuring objects. The VMS5200 is certified to the Measuring Instruments Directive specified in section 9.3 Compliance with EU directives.

The different nominal operating conditions according to the different nominal operating conditions depending on the object size are described below.

##### 3.5.1 Fixed scale values

If the plant is operated without scale value switchover, the measuring range and the scale interval value are fixed throughout the entire system depending on the application, and are therefore the same for all measured objects.

Measuring range and scale interval value for VMS5200 - operating condition 1				
	Min.	Max.	Scale value (d)	Note
<b>Length</b>	≥ 50 mm ≥ 2.0"	≤ 5,500 mm ≤ 216.0"	5 mm 0.2"	Longest dimension of the measuring object
<b>Width</b>	≥ 50 mm ≥ 2.0"	≤ 1,600 mm ≤ 63.0"	5 mm 0.2"	Dimension of the measuring object orthogonal to the longest dimension
<b>Height</b>	≥ 20 mm ≥ 1.0"	≤ 1,100 mm ≤ 43.0"	2 mm 0.1"	Maximum height of the measuring object relative to the transport belt surface

Tab. 1: Measuring range and scale interval value for VMS5200 - operating condition 1

Measuring range and scale interval value for VMS5200 - operating condition 2				
	Min.	Max.	Scale value (d)	Note
<b>Length</b>	≥ 50 mm ≥ 2.0"	≤ 5,500 mm ≤ 216.0"	5 mm 0.2"	Longest dimension of the measuring object
<b>Width</b>	≥ 50 mm ≥ 2.0"	≤ 1,600 mm ≤ 63.0"	5 mm 0.2"	Dimension of the measuring object orthogonal to the longest dimension
<b>Height</b>	≥ 50 mm ≥ 2.0"	≤ 1,100 mm ≤ 43.0"	5 mm 0.2"	Maximum height of the measuring object relative to the transport belt surface

Tab. 2: Measuring range and scale interval value for VMS5200 - operating condition 2

Measuring range and scale interval value for VMS5200 - operating condition 3				
	Min.	Max.	Scale value (d)	Note
<b>Length</b>	≥ 100 mm ≥ 4.0"	≤ 5,500 mm ≤ 216.0"	10 mm 0.4"	Longest dimension of the measuring object
<b>Width</b>	≥ 50 mm ≥ 2.0"	≤ 1,600 mm ≤ 63.0"	5 mm 0.2"	Dimension of the measuring object orthogonal to the longest dimension
<b>Height</b>	≥ 50 mm ≥ 2.0"	≤ 1,100 mm ≤ 43.0"	5 mm 0.2"	Maximum height of the measuring object relative to the transport belt surface

Tab. 3: Measuring range and scale interval value for VMS5200 - operating condition 3

Measuring range and scale interval value for VMS5200 - operating condition 4				
	Min.	Max.	Scale value (d)	Note
<b>Length</b>	≥ 100 mm ≥ 4.0"	≤ 5,500 mm ≤ 216.0"	10 mm 0.4"	Longest dimension of the measuring object
<b>Width</b>	≥ 100 mm ≥ 4.0"	≤ 1,600 mm ≤ 63.0"	10 mm 0.4"	Dimension of the measuring object orthogonal to the longest dimension
<b>Height</b>	≥ 50 mm ≥ 2.0"	≤ 1,100 mm ≤ 43.0"	5 mm 0.2"	Maximum height of the measuring object relative to the transport belt surface

Tab. 4: Measuring range and scale interval value for VMS5200 - operating condition 4

Measuring range and scale interval value for VMS5200 - operating condition 5				
	Min.	Max.	Scale value (d)	Note
<b>Length</b>	≥ 100 mm ≥ 4.0"	≤ 5,500 mm ≤ 216.0"	10 mm 0.4"	Longest dimension of the measuring object
<b>Width</b>	≥ 100 mm ≥ 4.0"	≤ 1,600 mm ≤ 63.0"	10 mm 0.4"	Dimension of the measuring object orthogonal to the longest dimension
<b>Height</b>	≥ 100 mm ≥ 4.0"	≤ 1,100 mm ≤ 43.0"	10 mm 0.4"	Maximum height of the measuring object relative to the transport belt surface

Tab. 5: Measuring range and scale interval value for VMS5200 - operating condition 5

Measuring range and scale interval value for VMS5200 - operating condition 6				
	Min.	Max.	Scale value (d)	Note
<b>Length</b>	≥ 100 mm ≥ 4.0"	≤ 5,500 mm ≤ 216.0"	10 mm 0.4"	Longest dimension of the measuring object
<b>Width</b>	≥ 50 mm ≥ 2.0"	≤ 1,600 mm ≤ 63.0"	5 mm 0.2"	Dimension of the measuring object orthogonal to the longest dimension
<b>Height</b>	≥ 20 mm ≥ 1.0"	≤ 1,100 mm ≤ 43.0"	2 mm 0.1"	Maximum height of the measuring object relative to the transport belt surface

Tab. 6: Measuring range and scale interval value for VMS5200 - operating condition 6

Measuring range and scale interval value for VMS5200 - operating condition 7				
	Min.	Max.	Scale value (d)	Note
<b>Length</b>	≥ 100 mm ≥ 4.0"	≤ 5,500 mm ≤ 216.0"	10 mm 0.4"	Longest dimension of the measuring object
<b>Width</b>	≥ 100 mm ≥ 4.0"	≤ 1,600 mm ≤ 63.0"	10 mm 0.4"	Dimension of the measuring object orthogonal to the longest dimension
<b>Height</b>	≥ 20 mm ≥ 1.0"	≤ 1,100 mm ≤ 43.0"	2 mm 0.1"	Maximum height of the measuring object relative to the transport belt surface

Tab. 7: Measuring range and scale interval value for VMS5200 - operating condition 7

Measuring range and scale interval value for VMS5200 - operating condition 8				
	Min.	Max.	Scale value (d)	Note
<b>Length</b>	≥ 200 mm ≥ 8.0"	≤ 5,500 mm ≤ 216.0"	20 mm 0.8"	Longest dimension of the measuring object
<b>Width</b>	≥ 50 mm ≥ 2.0"	≤ 1,600 mm ≤ 63.0"	5 mm 0.2"	Dimension of the measuring object orthogonal to the longest dimension
<b>Height</b>	≥ 20 mm ≥ 1.0"	≤ 1,100 mm ≤ 43.0"	2 mm 0.1"	Maximum height of the measuring object relative to the transport belt surface

Tab. 8: Measuring range and scale interval value for VMS5200 - operating condition 8

Transport conditions for dynamic presence detection
Cubic and irregularly shaped objects on flat conveyor systems $v_{min}: \geq 0.1 \text{ m/s}$ $v_{max}: \leq 4.0 \text{ m/s}$ , start/stop operation permitted Minimum distance between objects: 50 mm / 2"

#### 3.5.2 Dynamic scale value switchover

With dynamic scale value switchover, the scale interval value can be changed depending on the relevant measured object dimension, i.e., length, width, or height.

The change to the second scale interval value occurs separately for each dimension value once that dimension has reached the preset switchover point. It is therefore possible to individually change scale values, i.e. if one dimension is greater or less than the predefined switchover point, only the scale value for that dimension is changed.

For example, if the switchover point is defined for the length dimension, a length that exceeds the switchover point will result in scale value 2 being applied to the length. Scale value 1 will continue to apply to the determined width and height.

The switchover point is set during commissioning and cannot be changed when the calibration switch is activated and locked (for information on the calibration switch, see section [3.6.3 Alibi memory and firmware](#)). Scale interval value 1 and scale interval value 2 must be documented on two separate information labels. Only scale interval values based on the nominal operating conditions may be selected.

Example 1

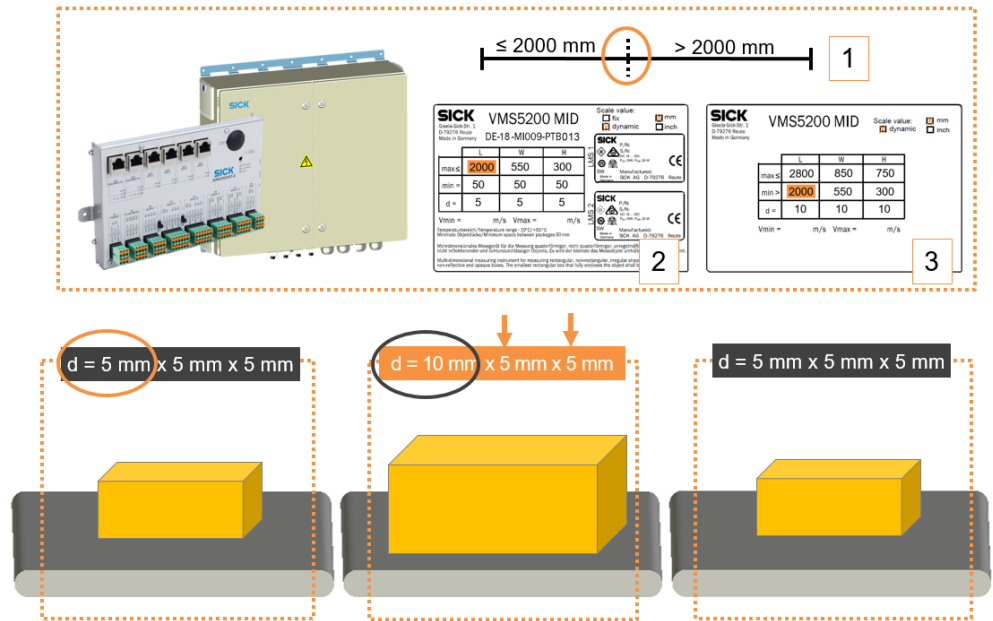

Fig. 18: Dynamic scale value switchover (length dimension as switchover point)

Legend

- 1 Switchover point 2,000 mm
- 2 Identification label for scale interval value 1
- 3 Identification label for scale interval value 2

In example 1, the multi-dimensional measurement system is working with the two scale interval values 5 mm x 5 mm x 5 mm and 10 mm x 5 mm x 5 mm. An object length of 2,000 mm has been defined as the switchover point during commissioning.

Objects with a length less than or equal to 2,000 mm are measured with scale interval value 1 (5 mm x 5 mm x 5 mm). For objects with a length greater than 2,000 mm, the multi-dimensional measurement system automatically uses scale interval value 2 (here 10 mm) for the length dimension due to the detected object length, and continues to use scale interval value 1 (here 5 mm x 5 mm) for the width and height.

### 3 SYSTEM DESCRIPTION

#### Example 2

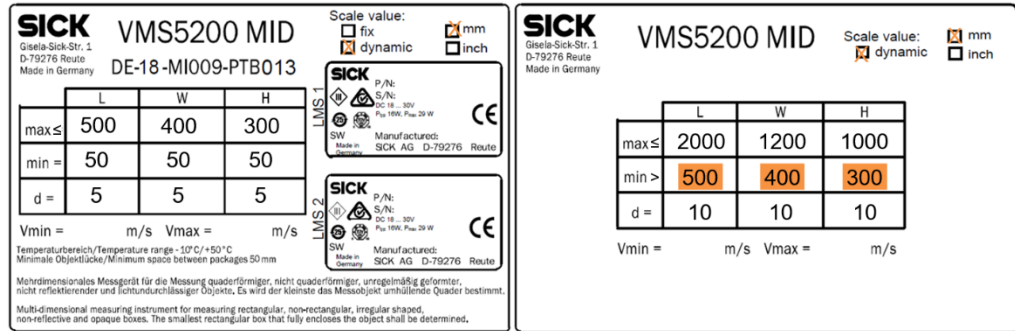

Fig. 19: Dynamic scale value switchover (switching point for length, width and height)

In example 2, the multi-dimensional measurement system is working with the two scale interval values 5 mm x 5 mm x 5 mm and 10 mm x 10 mm x 10 mm. The change of scale interval values occurs for all three dimensions. The switching points are 500 mm for the length, 400 mm for the width, and 300 mm for the height.

The following table shows the scale interval values based on each respective measured object dimension.

L	B	H	d			L <sub>min</sub>	L <sub>max</sub>	B <sub>min</sub>	B <sub>max</sub>	H <sub>min</sub>	H <sub>max</sub>
mm	mm	mm	mm			mm	mm	mm	mm	mm	mm
450	350	250	5	5	5	445	455	345	355	245	255
450	250	350	5	5	10	445	455	245	255	340	360
350	450	250	5	10	5	345	355	440	460	245	255
350	250	450	5	5	10	345	355	245	255	440	460
250	450	350	5	10	10	245	255	440	460	340	360
250	350	450	5	5	10	245	255	345	355	440	460



### 3.6 Legal for trade operation

The MID-compliant, and therefore officially verifiable, VMS5200 system has been type-tested by the Physikalisch-Technische Bundesanstalt (PTB). It can therefore be used for billing purposes.

When operating the VMS5200 in a situation requiring official legal-for-trade verification, be sure to comply with applicable national law. SICK can assist you with this in an advisory capacity on request. However, this assistance is not a substitute for legal advice.

#### 3.6.1 Information labels

There are several types of information labels in use:

#### System information labels

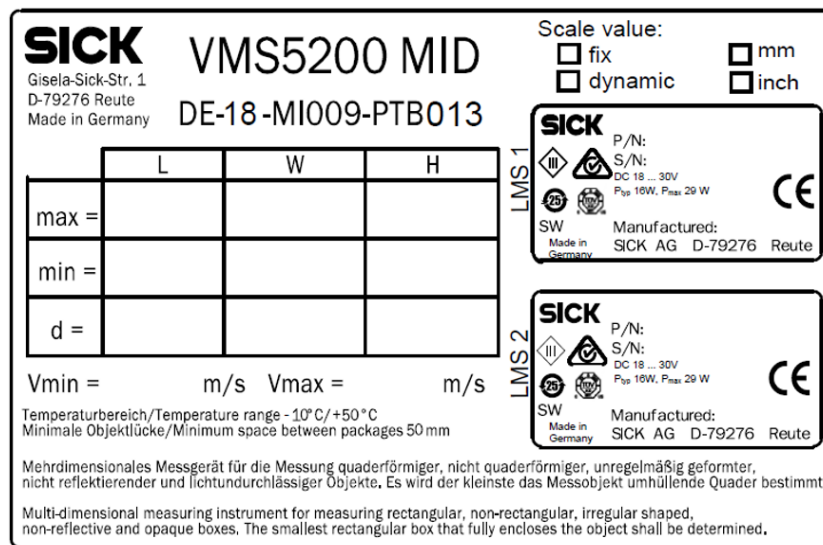

Fig. 20: System information label of the VMS5200 with attached type labels of the 2D LiDAR sensors

- To ensure that the VMS5200 is operated in such a way that it can be verified as legal for trade, one or two **system information labels** – depending on whether fixed scale values or dynamic scale value switchover are used – containing information about the maximum and minimum dimensions for the length (L), width (W), and height (H), as well as the relevant scale value (d) must be attached to the multi-dimensional measurement system in a highly visible location.
- The missing values are to be entered by hand on site, using waterproof permanent ink. Alternatively, printable templates are available online.
- The type labels of the 2D LiDAR sensors contain additional information and are to be affixed to the information label in the **LMS 1** and **LMS 2** fields. The **SW** field contains the version number of the device software.
- Each system identification label must be attached to the system in such a manner that it can be seen by the operator and associated with the multi-dimensional measurement system.

### 3 SYSTEM DESCRIPTION

#### Metrology information label of the VMS5200

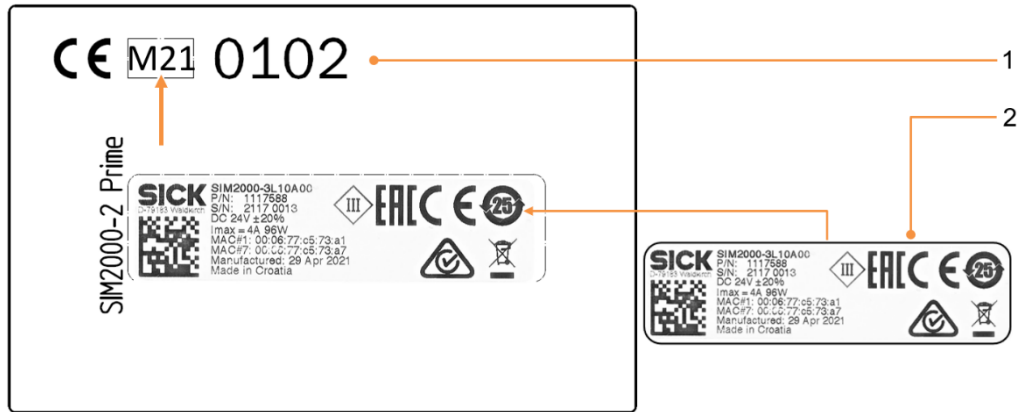

Fig. 21: Sample label for the metrology information label, CE marking, and number of the notified body with SIM2000-2 Prime controller type label

#### Legend

- 1 Metrology marking
- 2 Type label of the SIM2000-2 Prime controller

- A **metrology identification label** must also be attached.
- The metrology marking – **M21** for the year 2021 in the above figure – must be indicated in accordance with Article 21 of the MID.
- Additionally, the CE marking and the number of the notified body – **0102** for PTB in the above figure – must be indicated.
- After successful commissioning and conformity assessment, the type label of the SIM2000-2 Prime controller must be affixed to the metrology information label.

**NOTE!** The nature of the metrology information label must be such that its removal will result in the destruction of the label itself or of a security seal.

**System information labels with fixed scale values**

If fixed scale values are defined for the VMS5200, the **fix** option is to be marked on the system identification label. The associated dimension values with unit of measurement (**mm** or **inch**) must be specified in indelible ink. The LMS4x21 2D LiDAR sensor type labels must be affixed in the appropriate fields.

The type label for the SIM2000-2 Prime controller must be affixed to the metrology information label in the appropriate field.

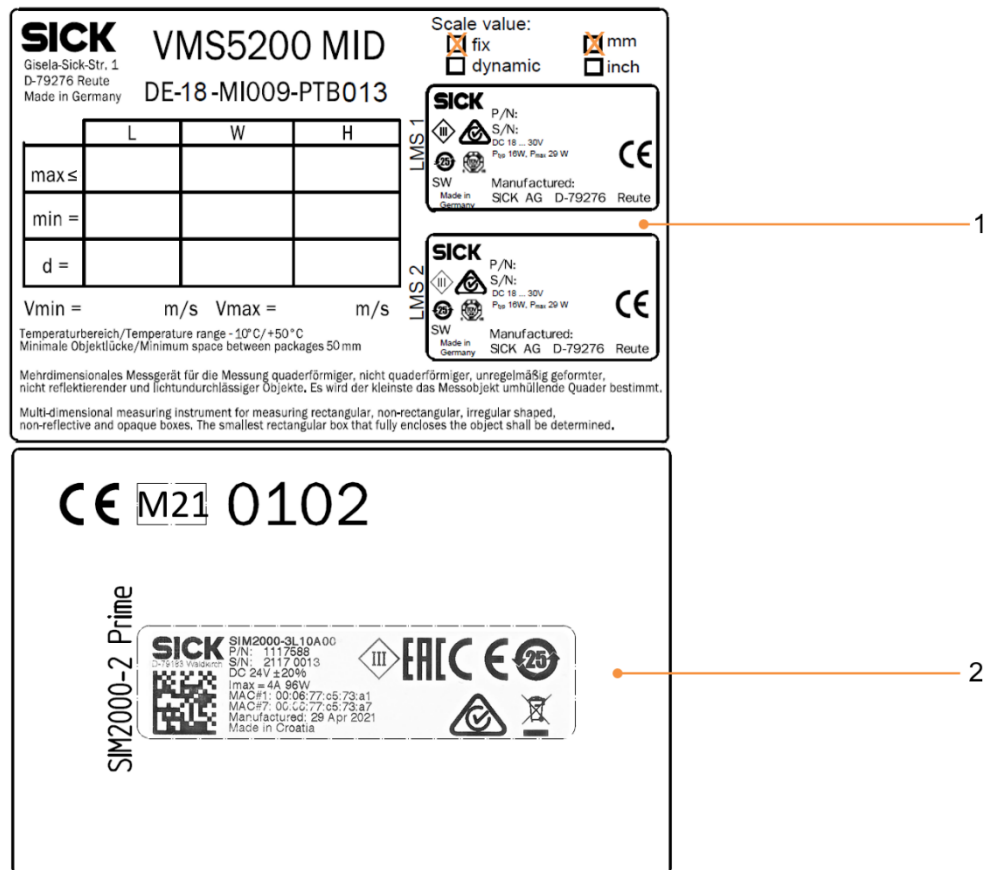

Fig. 22: Information labels for the VMS5200 for fixed scale values with affixed type labels

**Legend**

- 1 System information labels with fixed scale values
- 2 Metrology information label with affixed type label

### 3 SYSTEM DESCRIPTION

#### Information labels with dynamic scale value switchover

For dynamic scale value switchover, the scale values for two scale interval values used must be described in two separate information labels. For scale interval value 1, the **dynamic** option on the system information label should be marked. The dimension values with unit of measurement (**mm** or **inch**) must be specified in indelible ink. On the information label for scale interval value 2, the **dynamic** scale value and the measuring unit (**mm** or **inch**) with the accompanying dimension values must be specified.

The type labels for the LMS4x21 are also affixed to this information label.

The type label for the SIM2000-2 Prime controller must be affixed to the metrology information label in the appropriate field.

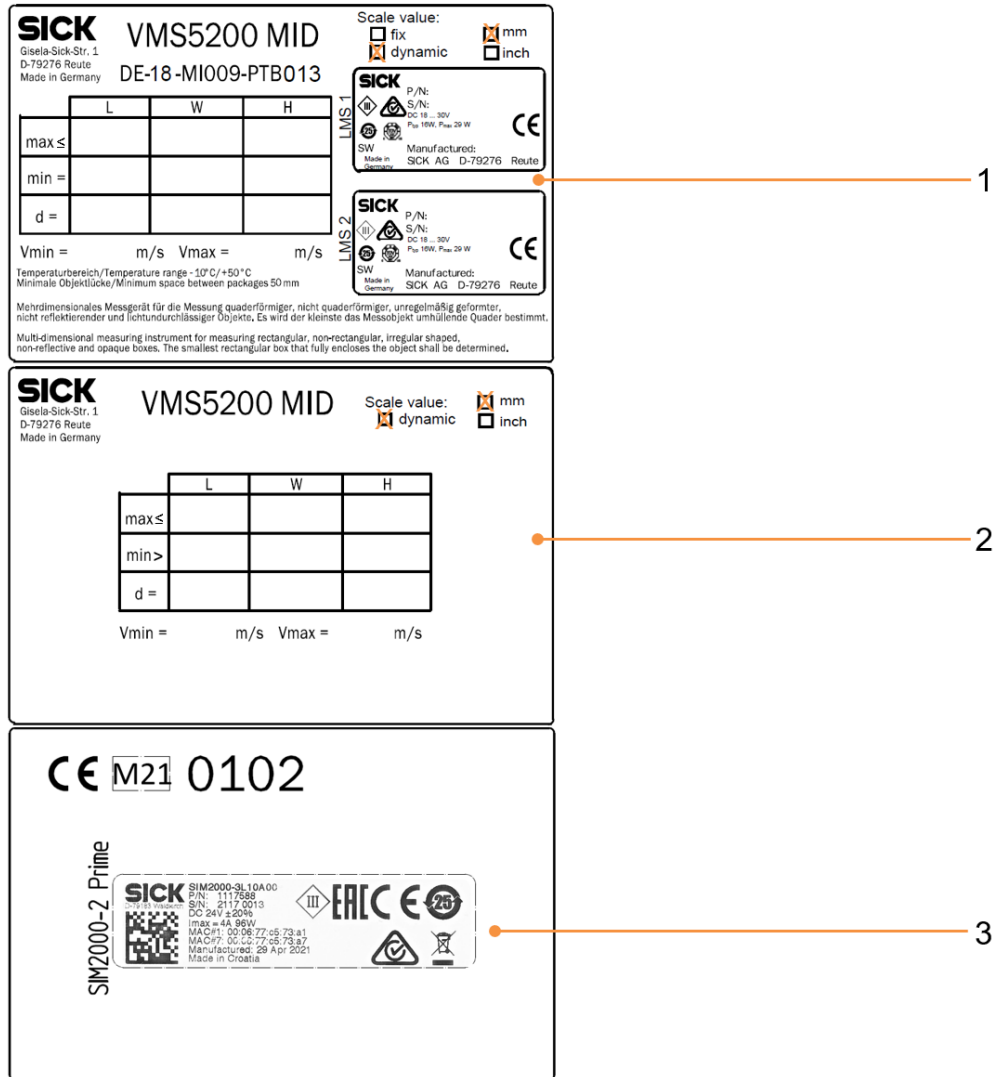

Fig. 23: Information labels for the VMS5200 for dynamic scale value switchover with affixed type labels

#### Legend

- 1 System information label for scale interval value 1
- 2 System information label for scale interval value 2
- 3 Metrology information label with affixed type label

### 3.6.2 Security seal

In order to protect measurement systems that have been verified as legal for trade against manipulation, all legally relevant components that influence the measurement result must be provided with seals in accordance with the seal diagram depicted in the figure below.

The security seals are attached to the VMS5200 components after mounting and the conformity check.

**NOTE!** Never break any seals. A broken seal causes the legal for trade calibration period to end ahead of schedule. Use of the VMS5200 for billing purposes is then no longer permitted.

- ▶ The incident must be reported to the manufacturer and the office of weights and measures.

#### Seal on the 2D LiDAR sensor

Security seals prevent the attachment mechanism of the 2D LiDAR sensors and the plug connections of the connections from misaligning.

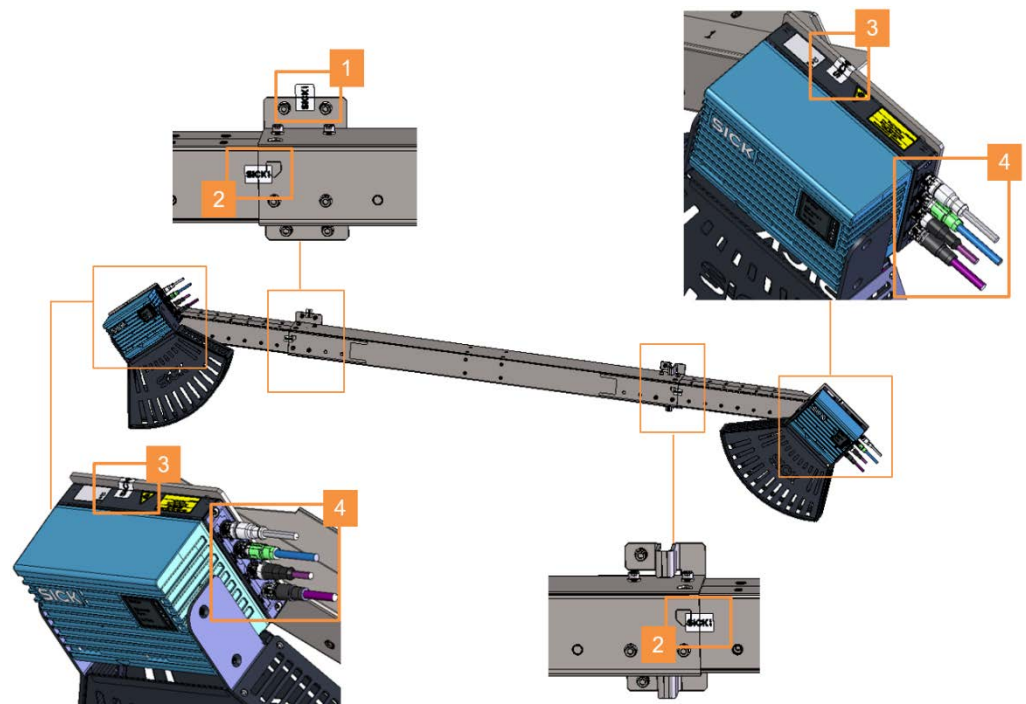

Fig. 24: Security seal on the 2D LiDAR sensors of the VMS5200

#### Legend

- |   |   |
|---|---|
| 1 | Security seal on the mounting plate of the modular bracket on the frame |
| 2 | Security seal on the two adjusters of the telescopic tube               |
| 3 | Security seal on the mounting plates of the 2D LiDAR sensors            |
| 4 | Security seal on all plug connections for the electrical connections    |

### 3 SYSTEM DESCRIPTION

#### Seals on the deflector mirror

In system setups with deflector mirror, the attachment mechanism is secured with security seals.

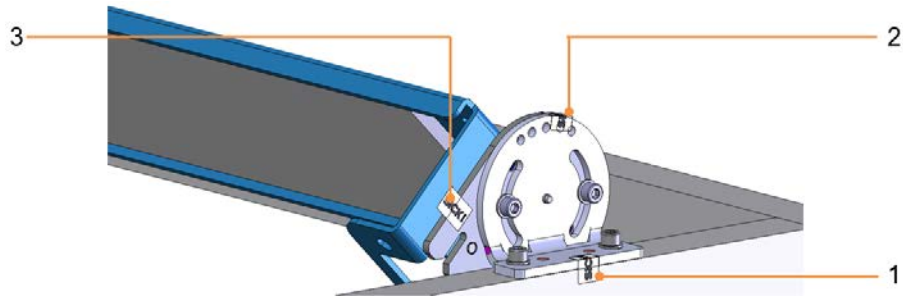

Fig. 25: Security seals on the deflector mirror

#### Legend

- 1 Security seal on the contact point between mounting bracket/  
mounting frame
- 2 Security seal on the contact point between mounting bracket/  
system mount
- 3 Security seal on the contact point between mounting bracket/  
mirror holder

#### Security seal on SIM2000-2 Prime controller

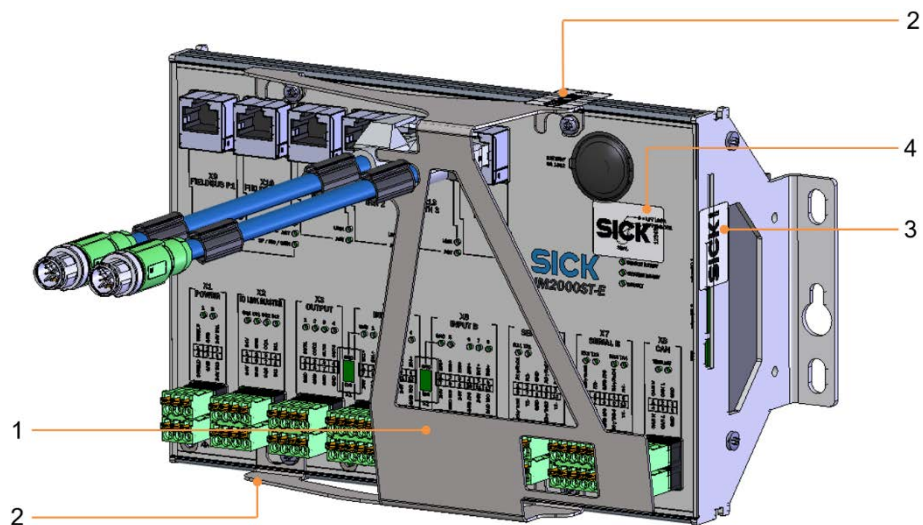

Fig. 26: SIM2000-2 Prime controller security seal

#### Legend

- 1 Manipulation guard
- 2 Security seal on the manipulation guard
- 3 Security seal on card slot with alibi memory card
- 4 Security seal on calibration switch

- A manipulation guard protects the SIM2000-2 Prime controller installed in the cabinet against disassembly and removal of the legally-relevant connections.
- The manipulation guard is sealed.

**NOTE** The two adhesive seal are also a form of protection against unauthorized opening of the SIM2000 housing.



- The card slot is sealed to prevent removal of the alibi memory card.
- The calibration switch is sealed to prevent it from being misaligned.

### Securing the data connections

The legally relevant data lines are protected against disconnection by a manipulation guard (Ethernet connections X13 and X14 in this example).

**NOTE!** The X11 and X12 Ethernet connections and/or fieldbus connections can be considered legally relevant. In this case, an appropriately modified manipulation guard is applied.

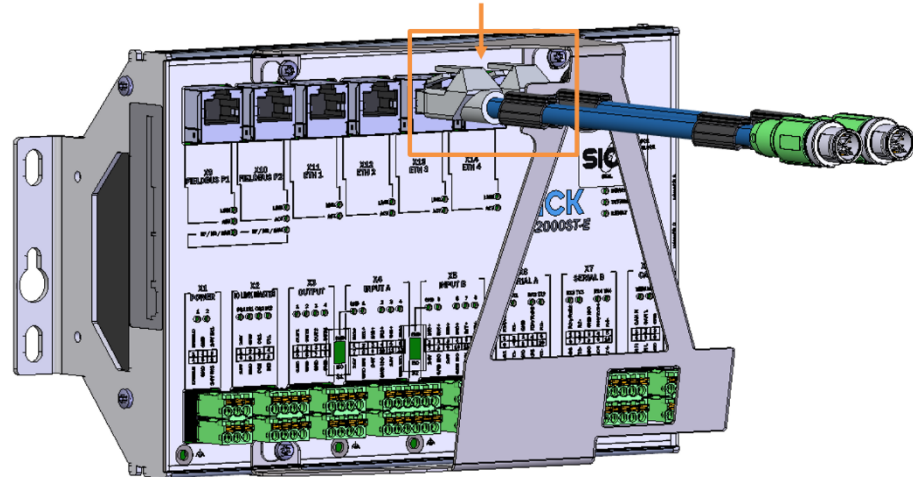

Fig. 27: Securing the legally relevant Ethernet connections (X13 + X14 in this example) of the SIM2000-2 Prime controller in the VMS5200 MID

### Securing connected sensors and I/Os

The connections of legally relevant sensors and I/Os of the SIM2000-2 Prime controller are secured by covering the relevant plug connectors with a manipulation guard.

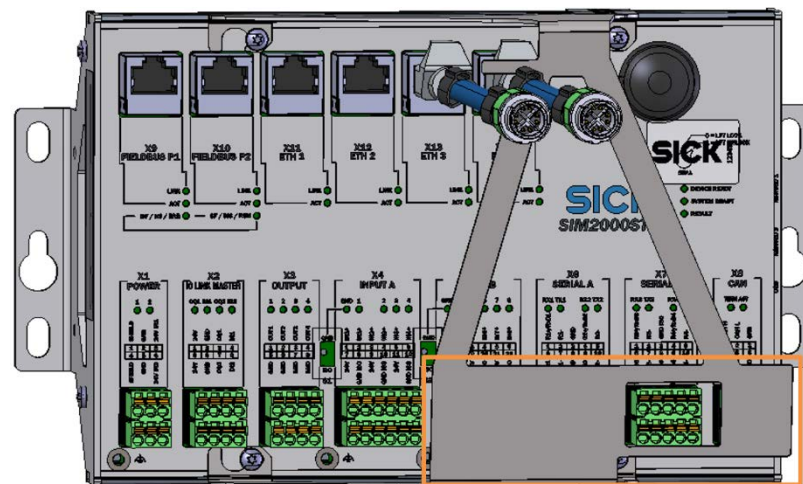

Fig. 28: Securing connected sensors and I/Os of the SIM2000-2 Prime controller in the VMS5200 MID

### 3 SYSTEM DESCRIPTION

#### Calibration switch and alibi memory card security

Secure the alibi memory card in the designated card slot on the right side of the SIM2000-2 Prime controller with an adhesive seal on the slot opening.

Secure the calibration switch on the front of the SIM2000-2 Prime controller with an adhesive seal on the switch.

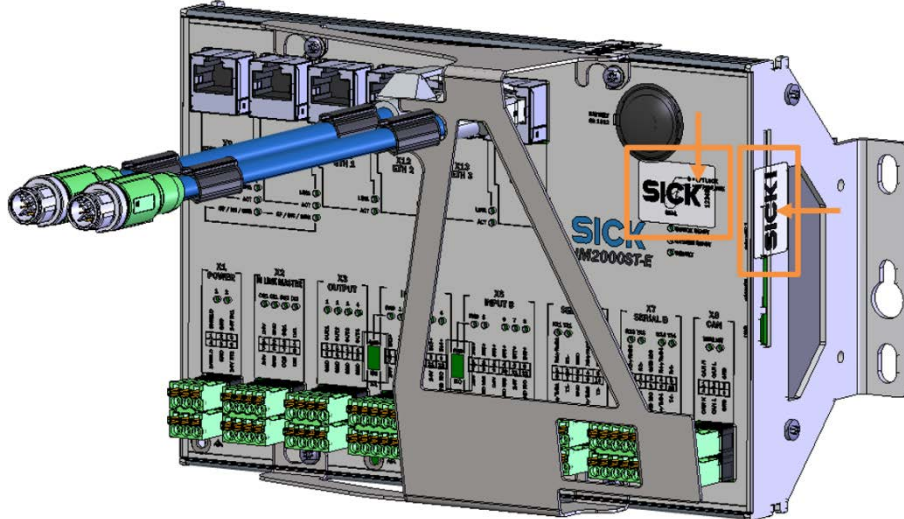

Fig. 29: Securing the alibi memory card with security seal on the card slot of the SIM2000-2 Prime controllers and securing the calibration switch with security seal on the switch on the front of the housing

#### Security seal on LFT Ethernet switch

A manipulation guard protects the LFT Ethernet switch against disassembly and removal of the connecting cables.

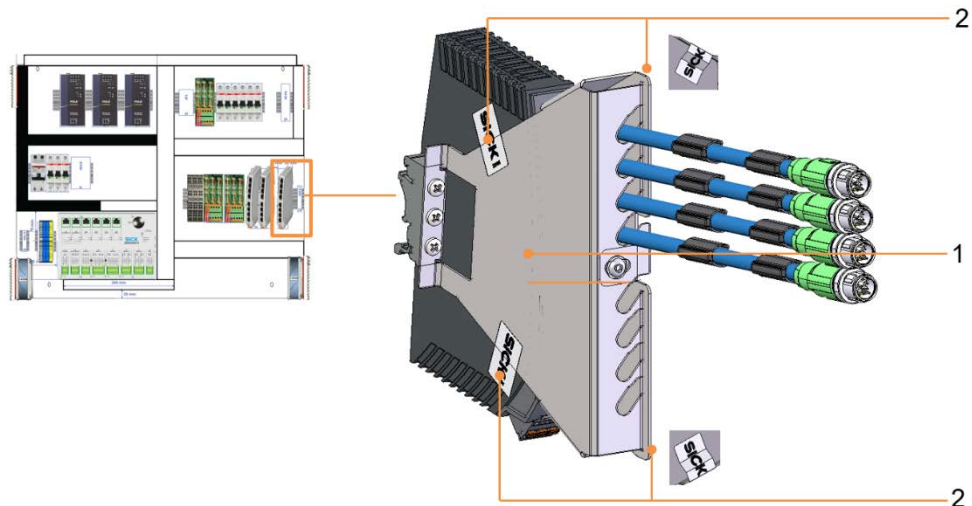

Fig. 30: LFT Ethernet switch security seals

#### Legend

- 1 Manipulation guard.
- 2 Security seal on the manipulation guard.



### Security seals on the incremental encoder

The incremental encoder is protected against disassembly and disconnection of the connecting cable by corresponding adhesive seals.

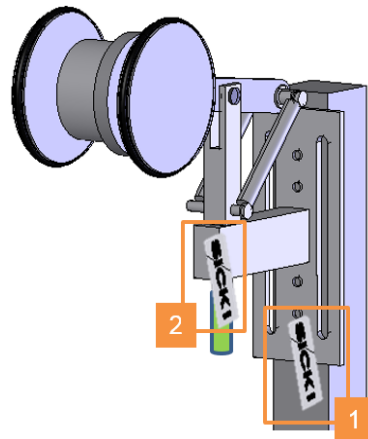

Fig. 31: Security seals on the incremental encoder (DFV60 in this image)

#### Legend

- |   |                                     |
|---|-------------------------------------|
| 1 | Security seal on the bracket        |
| 2 | Security seal on the male connector |

### Security seals on the LFT display

The LFT display is protected against disassembly and disconnection of the connecting cable by corresponding adhesive seals.

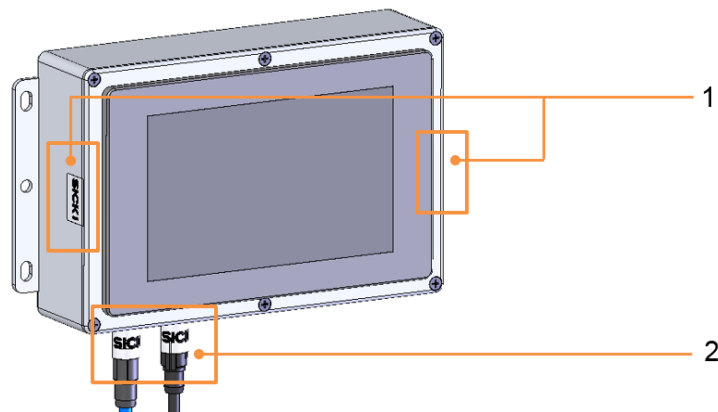

Fig. 32: Security seals on the LFT display

#### Legend

- |   |  |
|---|--|
| 1 | Security seal on the LFT display housing |
| 2 | Security seal on the male connectors.    |

### 3 SYSTEM DESCRIPTION

#### 3.6.3 Alibi memory and firmware

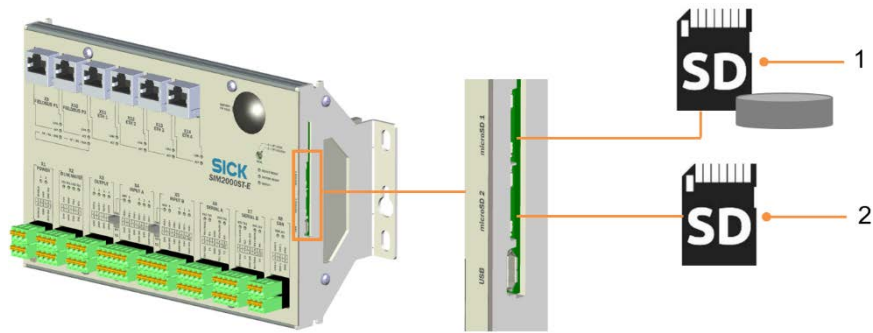

Fig. 33: Micro SD card with alibi memory and firmware

---

#### Legend

- |   |  |
|---|--|
| 1 | MicroSD1 card slot<br>MicroSD card with alibi memory.                                |
| 2 | MicroSD2 card slot<br>MicroSD card containing the firmware (included with delivery). |
- 

#### SD card with alibi memory

- Measurement and calibration legislation stipulates that a measured value which is detected on a measurement device that has been verified as legal for trade in an application requiring official verification and is transmitted to an electronic data processing system must be documented in a manipulation-proof manner for a period dating back at least 90 days.
- Documentation occurs in the alibi memory on the SD card of the SIM2000-2 Prime controller. The alibi memory must be approved by the Physikalisch-Technische Bundesanstalt (PTB) or another notified body.
- The VMS5200 ensures compliance with calibration legislation for measurement data as well as the traceability of all measurement processes in the measurement system. For this purpose, all measured values obtained are stored in a legally compliant manner in the alibi memory along with their date, time, and a unique consecutive alibi ID (“identification index”), which together form the legally relevant identifier of a measurement data record.

The manipulation-proof status of the alibi memory storage was verified as part of an official WELMEC SW check by the appropriate authority.



### 3 SYSTEM DESCRIPTION

#### Firmware

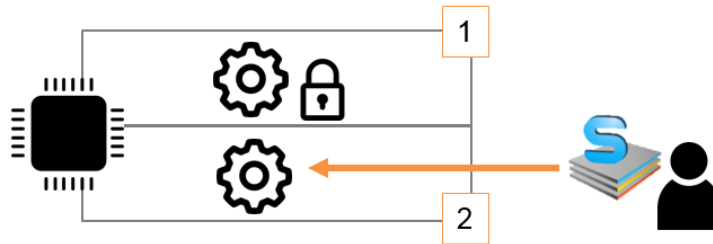

Fig. 35: Separation of firmware into an application part and a metrologically relevant part

#### Legend

- |   |                              |
|---|------------------------------|
| 1 | Metrologically relevant part |
| 2 | Application                  |

- The firmware is separated into an **application part** and a **metrologically relevant part**.
- The separation allows customer-specific parameters to be changed via the SOPAS configuration software without violating the LFT conformity of the multi-dimensional measurement system.

#### Calibration switch



Fig. 36: Calibration switch for interlocking the metrological software parameters

- The software relevant to the LFT conformity with the accompanying LFT parameters is protected by a calibration switch.
- The calibration switch is located on the front of the SIM2000-2 Prime ST-E controller.
- It is interlocked by turning the calibration switch to the zero position.

## 3.6.4 LFT display

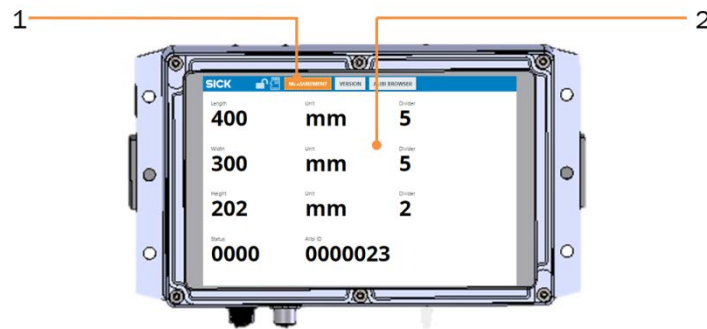

Fig. 37: User interface of the LFT display

## Legend

- |   |                               |
|---|-------------------------------|
| 1 | Menu bar with individual tabs |
| 2 | Display pane                  |

## Features

- When operated in a legal-for-trade application, the VMS5200 also includes a separate LFT display.
- To control the display, gently touch the respective button (touchscreen).  
**NOTE!** Only touch the display with your fingers. Do not apply pressure, and do not use pointed objects.

## Function

- Is used to display the measurement results during operation.
- Allows the display of status information, firmware versions and the logbook (version history) for market surveillance.  
**NOTE!** Measurement and system data cannot be edited.

## MEASUREMENT

SICK		
MEASUREMENT	VERSION	ALIN BROWSER
Length	Unit	Divider
<b>400</b>	<b>mm</b>	<b>5</b>
Width	Unit	Divider
<b>300</b>	<b>mm</b>	<b>5</b>
Height	Unit	Divider
<b>202</b>	<b>mm</b>	<b>2</b>
Status	ALIN ID	
<b>0000</b>	<b>0000023</b>	

Fig. 38: LFT display – display of the measurement results

- Visualizes the results of the last measurement.
- The length, width, and height are output with scale values in mm.
- The status provides additional information about the measurement result. Valid measurement results have the status **0 0 0 0**. Other numerical sequences indicate the reason why a measurement was invalid.

### 3 SYSTEM DESCRIPTION

#### VERSION

Displays the current firmware version, the associated firmware checksum, and the parameter checksum for all LFT-relevant devices (SIM2000, LMS4x21 and LFT display).

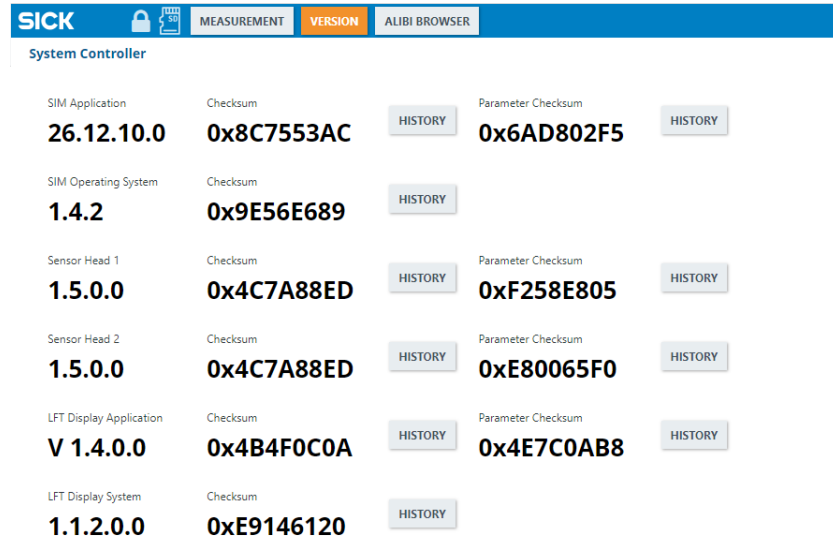

Fig. 39: LFT display – display of the firmware versions

- Displays the firmware history per system component including the associated firmware checksums for all LFT-relevant devices (SIM2000, LMS4x21 and LFT display).
- Accessed via the **HISTORY** button in the **Checksum** column.

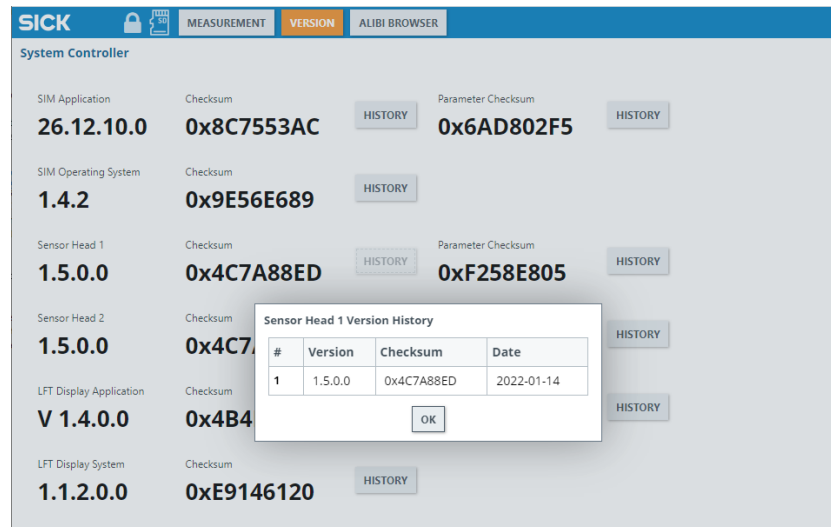

Fig. 40: LFT display – display of the firmware versions (history)

- Displays the parameter checksum history for all LFT-relevant devices (SIM2000, LMS4x21 and LFT display).
- Accessed via the **HISTORY** button in the **Parameter Checksum** column.

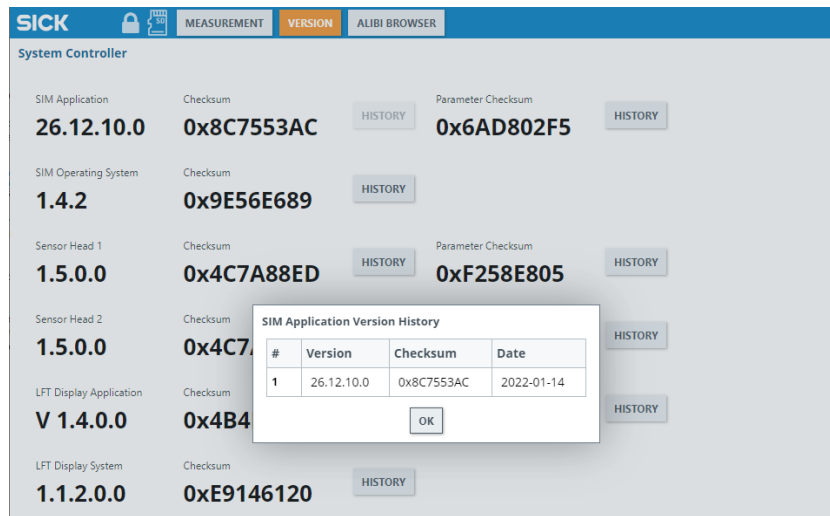

Fig. 41: LFT display – display of the parameter checksum history

ALIBI BROWSER

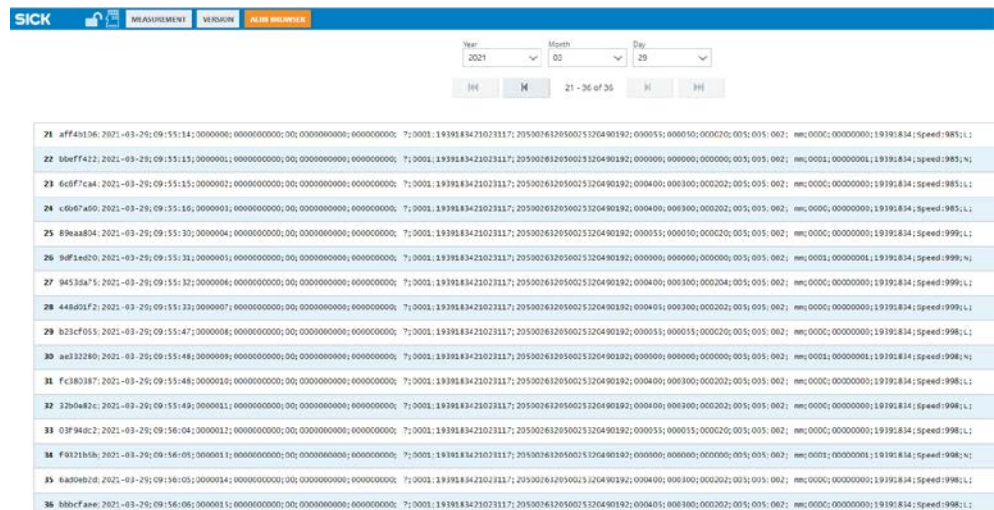

Fig. 42: LFT display – display of the data sets saved in the alibi memory

- Outputs the alibi data sets.
- Enter a starting date for displaying the data sets. The display is automatically updated.

#### 3.6.5 Test instructions for market surveillance

This section describes the procedure for inspecting the certified VMS5200 measurement system with regard to:

- The performance of metrological measurements with defined test objects and the display of the measurement results on the LFT display.
- The display of data sets stored in the alibi memory on the LFT display.
- The display of system component firmware versions via the LFT display.

##### Starting the system

- ▶ Establish the voltage supply to the devices via the power supply unit in the cabinet.
- All system components start up automatically and are then ready for use.
- The **MEASUREMENT** tab is active in the menu bar. No measured values are available yet.

##### Measuring test objects

- ▶ Measure test objects made from a dimensionally stable material of various shapes and surface qualities.
- ▶ Perform the measurements.  
**NOTE!** The nominal dimensions (length, width, height) must cover approximately 90%, 50%, and 10% of the total measuring range for each dimension. The actual dimensions must not be less than the minimum dimensions or exceed the maximum dimensions specified for the VMS5200.
- ▶ Ensure that the required minimum distance of 50 mm is maintained between the test objects.
- ▶ Compare the actual values for each measured test object with the dimension values on the LFT display.

##### NOTE!

Valid measurement results have the status **0 0 0 0**. They are LFT-verified and can be used for billing.

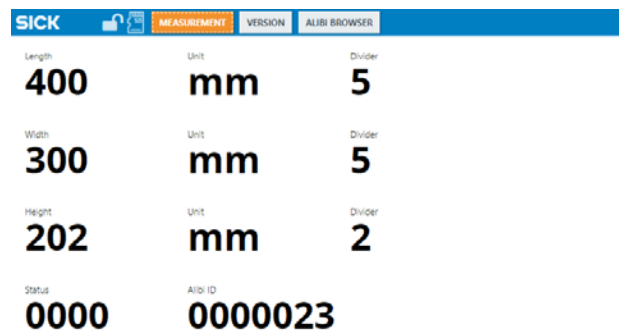

The screenshot shows the SICK measurement system interface. At the top, there is a menu bar with the SICK logo and three tabs: MEASUREMENT (highlighted), VERSION, and ALIBI BROWSER. Below the menu bar, the interface displays measurement data for three dimensions: Length, Width, and Height. Each dimension is shown with its value, unit, and divider. At the bottom, the status and Alibi ID are displayed.

Length	Unit	Divider
400	mm	5
Width	Unit	Divider
300	mm	5
Height	Unit	Divider
202	mm	2
Status	Alibi ID	
0000	0000023	



Displaying values saved in the alibi memory

- ▶ Tap **ALIBI BROWSER** in the menu bar.

The data sets saved in the alibi memory are listed line by line. A maximum of 20 data sets can be displayed on one page.

**NOTE!** Valid measurement results have the status **0 0 0 0**. They are LFT-verified and can be used for billing.

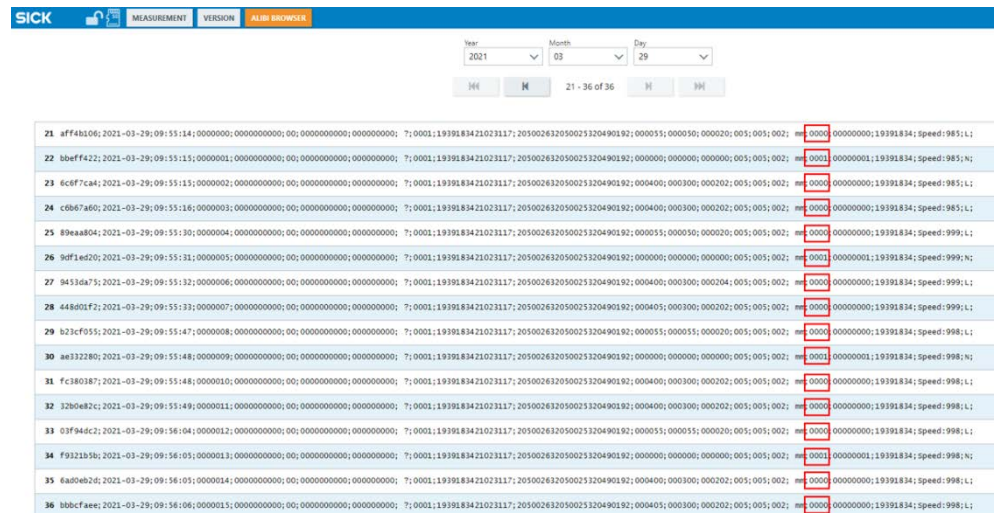

- ▶ Use the arrow buttons to change between individual pages.
- ▶ Note the display of the current page number and the total number of pages.

Icon	Meaning
	Opens the first page.
	Changes from the current page to the previous page.
	Changes from the current page to the next page.
	Opens the last page.

- ▶ Enter a date to limit the period for the displayed data sets. This list is updated automatically.

### 3 SYSTEM DESCRIPTION

#### Displaying firmware versions

► Tap **VERSION** in the menu bar.

On the left-hand side, the current firmware status of the system components is displayed together with the checksum saved in the SIM2000-2 Prime controller.

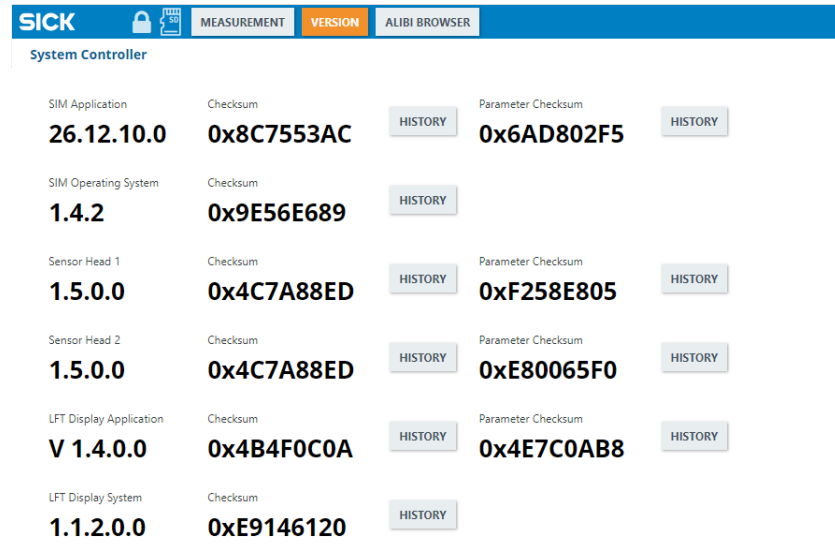

► Tap the **HISTORY** button to call up current and older versions for a component.

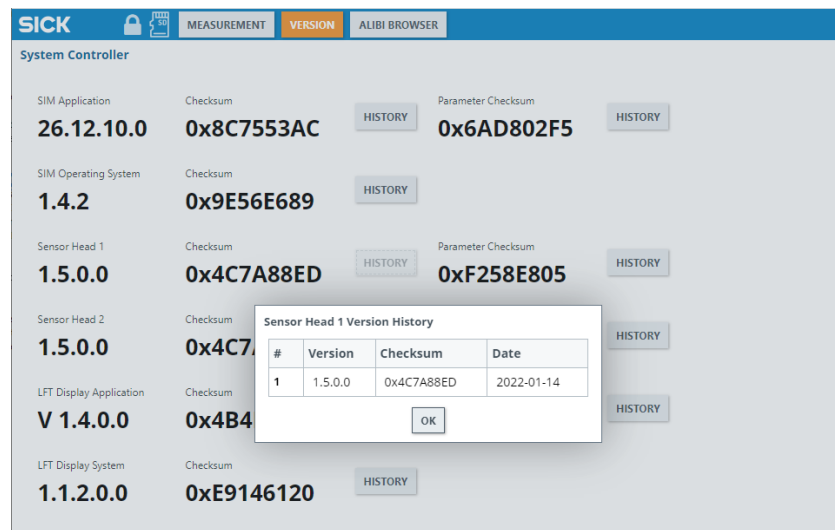

**Displaying the history of the checksum for LFT parameters**

- ▶ Tap **VERSION** in the menu bar.

The checksum of the metrologically relevant LFT check parameters saved in the SIM2000-2 Prime controller and in the individual system components is displayed in the **Parameter Checksum** column.

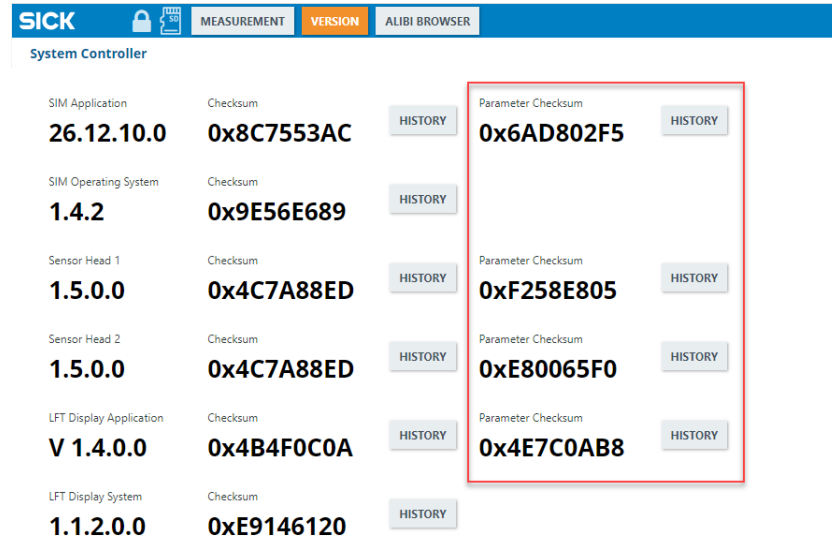

- ▶ Tap the **HISTORY** button to the right of the parameter checksum to call up current and older checksums of the LFT parameters.

**NOTE!** Altered LFT parameters must be officially disclosed to the appropriate weights and measures authority (“maintenance provider”).

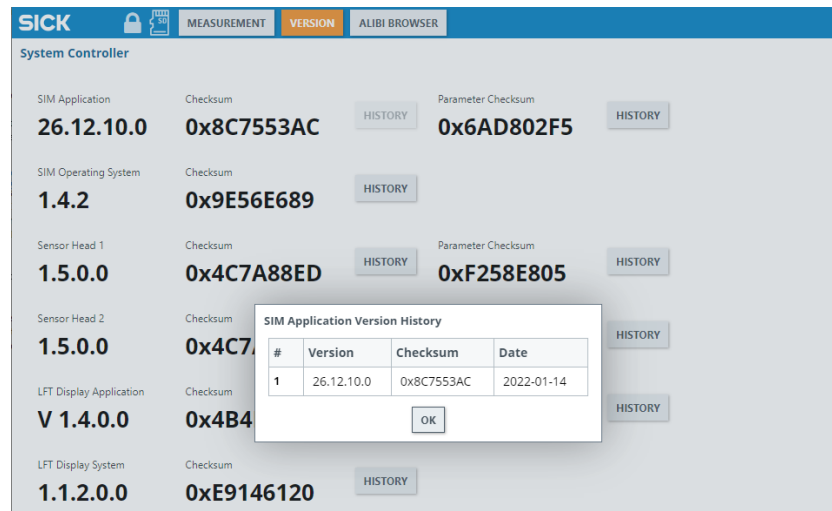

### 3.7 System requirements for legal for trade operation

To ensure the object dimensions are measured in a consistent and reproducible manner and with maximum accuracy, the object limitations and ambient condition described in the following sections must be taken into consideration.

Any conditions outside the limits will lead to problems or a reduction in measurement accuracy.

#### 3.7.1 Requirements on the ambient conditions

The operation site of the multi-dimensional measurement system must have the following features:

- Closed or covered room
- Flat and firm surface
- Low-vibration environment
- Protected from wind and free of drafts
- Maximum ambient light: 2000 Lux
- No direct sunlight
- Clean and dry (air humidity 95%, non-condensing)
- Room temperature of -10 °C to 50 °C

Regardless of the space required for the components, there must be enough space at the operation site for the following activities:

- Reading the measurement results off the LFT display
- Opening the cabinet door completely
- Cleaning, maintenance, and service

#### 3.7.2 Requirements on the conveying equipment

The VMS4200/5200 multi-dimensional measurement system is designed for flat conveying systems.

- The objects must not slip during the measurement process. Slippage-free conveying must be ensured.
- The measuring objects must not be exposed to any vibrations during measurement.
- Relative movements of the measuring objects are not permitted during measurement.
- The conveyor speed must be within the permissible speed range of 0.1 m/s to 4.0 m/s.
- The conveyor belts must be synchronized and running at the same belt speed.
- Start/stop operation is permitted.

---

#### NOTE

- Any relative movement of an object to the conveyor belt will result in distorted measurement results.
  - If the objects rotate, vibrate, roll, or slip on the conveyor belt and on uneven conveying surfaces, accuracy may be impaired.
-

### General requirements

- In an area before and after the measuring station, the conveying equipment must run straight and evenly. The conveyor belt must have a uniform and flat surface. The front and back area corresponds to the maximum length of the measuring object (see also section [3.5 Nominal operating conditions](#)).

**NOTE!** If the specific installation position of the measuring system fails to satisfy this requirement, the maximum length for the measuring objects must be restricted accordingly and indicated on the identification label (see section [3.6.1 Information labels](#)).

- Positive or negative slopes of the conveying equipment must be kept flat enough to prevent the measuring objects from sliding.
- The conveying equipment must not have any shiny or reflective surfaces. This can have a negative impact on the measurement results.
- No guides for measuring objects may be installed in the vicinity of the measuring station.
- The objects must be measured separately (singulated). A minimum object separation of 50 mm is required.

**NOTE!** The customer must ensure that the required minimum distance is adhered to.

## 3 SYSTEM DESCRIPTION

### 3.7.3 Mounting requirements

- Frame**
- ▶ Use a stable frame that is secured to prevent twisting and has sufficient load-bearing capacity.
  - ▶ Attach the frame to the conveying system in such a way that it cannot shake or vibrate.
  - ▶ Align the frame at a right angle to the conveying direction.

**NOTE!** Use Item aluminum profiles.

#### LMS4x21

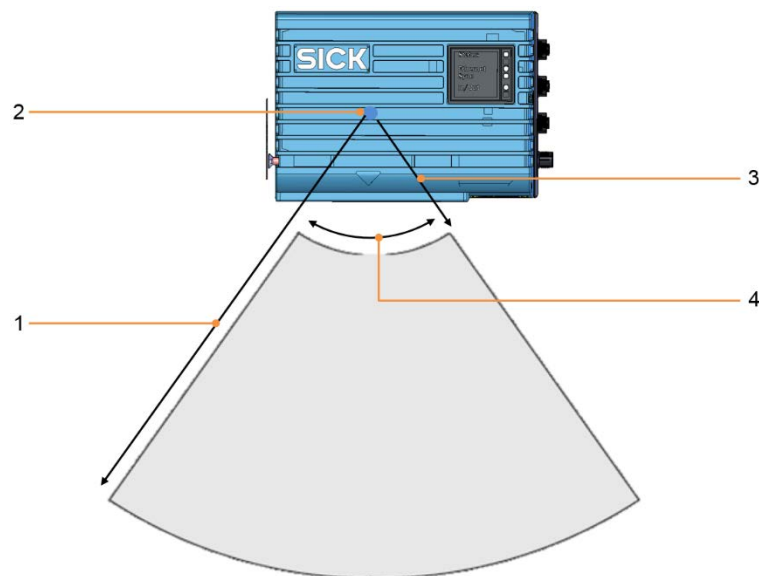

Fig. 43: Working range of the LMS4x21

---

#### Legend

- 1 Maximum working sensing range: 3 m
  - 2 Zero point of the distance measurement. In the delivery state, this point is the origin of the laser (marked with a point on the upper and lower side of the housing).
  - 3 Minimum distance between the zero point of the measurement and the measuring object: 900 mm
  - 4 Aperture angle: 70°
-

### Mounting the LMX4x21

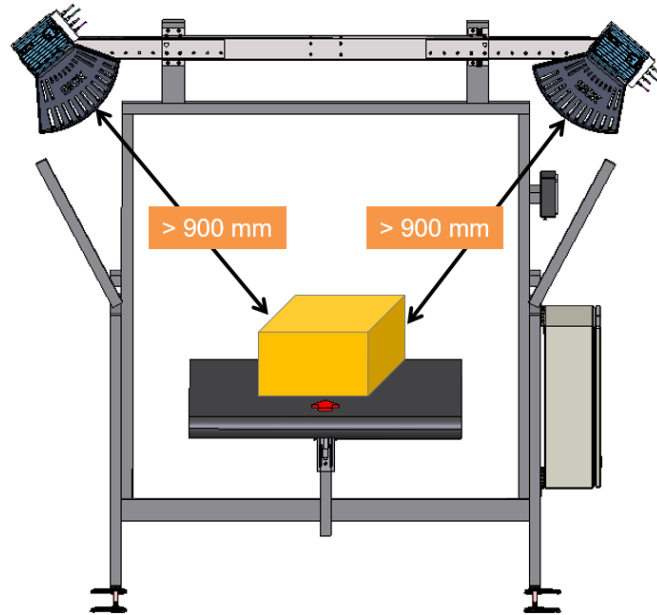

Fig. 44: Requirements for mounting the LMS4x21

- ▶ The 2D LiDAR sensors are mounted on the right and left of the conveyor in such a way that they are free of vibrations and oscillations.

**NOTE!** Use the supplied mounting kit with telescopic tube and fastening elements. See also section [4.1 Mounting 2D LiDAR sensors](#).

The telescopic tube must be mounted precisely at right angles to the conveying equipment.

### Optimizing the scan result

- The smallest permissible distance of the measuring object from the zero point of the LMS4x21 is typically 900 mm. The zero point is marked on both the upper and lower side of the housing of the LMS4x21.
- ▶ Observe the minimum distance of the LMS4x21 to the measuring object. The required space for installation of the 2D LiDAR sensor is approximately 900 mm above the tallest object.
- ▶ Maximum detection must be limited to a working sensing range of three meters. Otherwise, it may not be possible to attain the specified scale interval value.
- ▶ Make sure that the LMS4x21 has a clear view of the conveying equipment.
- Ensure sufficient distance of the LMS4x21 from curves, induction lines, start/stop areas, areas with upward and downward inclines, and breaks in the conveyor system.
- LFT measurements over the belt gap are not permitted.

### 3 SYSTEM DESCRIPTION

#### Beam restriction

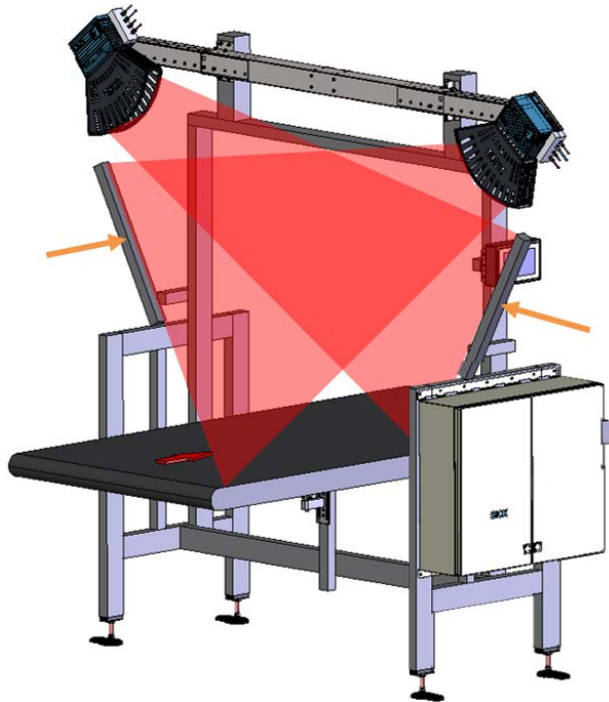

Fig. 45: Beam blockers for restricting the laser beams to the measuring range

- ▶ Attach beam blockers to the mounting frame to restrict LMS4x21 laser beams to the application space.

**NOTE!** Detection of people or objects located outside the measuring range is not permitted. This would otherwise distort the measurement result.

#### 3.7.4 Object requirements

##### Required object properties

- Dimensionally stable (not deformable)
- Opaque surface (not transparent)
- Non-reflective surface (no shiny or reflective surface)

##### Remission factor

The remission factor of the objects must be between 10% and max. 200%.

**NOTE!** Black objects with extremely low remission factor (< 10%) cannot be measured with high accuracy.

Object color	Remission factor [%]
Black cardboard	10
Blue	16
Red	75
White	98
Black with shiny tape	107



### Handling of dimensionally unstable objects



Fig. 46: Handling of dimensionally unstable objects

- Objects such as plastic bags or other unstable items are not suitable for MID-compliant dimensioning (automatic LFT billing).
- The shape and size of these types of objects are not dimensionally stable. The repeatability of the measurement result is therefore not guaranteed.

---

#### NOTE!

- After the manufacturer has placed the measurement system on the market, the operating entity must ensure that dimensionally unstable, transparent or reflective objects are excluded from billing operation.
  - The possibility of multiple objects being present on a single conveyor element must be excluded.
  - The so-called **operating entity's responsibility** applies!
- 

► The risk of incorrect measurements can be avoided as follows:

- Process the objects in a separate package stream that bypasses the LFT measurement.
- Use additional bar codes to identify dimensionally unstable objects and to tag the measurement as a non-LFT compliant measurement.
- Use a classification system for dimensionally unstable objects (e.g. Deep Learning) and tag the measurement results with a flag to indicate invalid measurement conditions.

### 4 Mounting

All transport, assembly, mounting, and electrical installation work must only be carried out by qualified persons.

- Qualified persons have the specialist training, skills, experience and knowledge of the relevant regulations and standards needed to be able to perform work assigned to them and to identify and avoid any potential dangers independently.
- Electricians have the professional training, skills, experience and knowledge of the relevant standards and provisions needed to work on electrical systems and to detect and avoid any potential dangers independently.

#### 4.1 Mounting 2D LiDAR sensors

##### 4.1.1 Overview

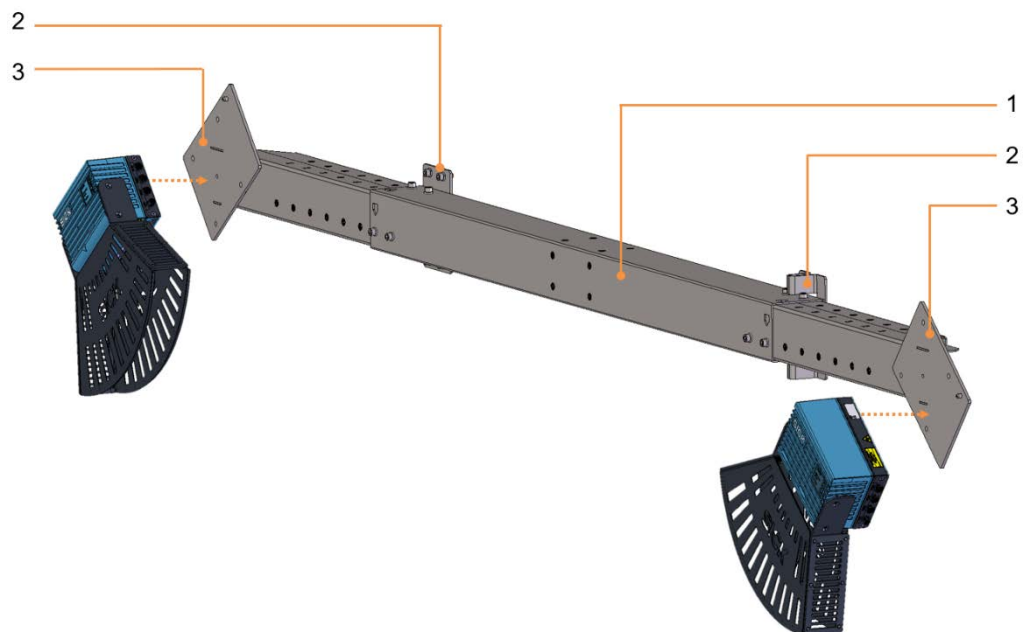

Fig. 47: Mounting the 2D LiDAR sensors

---

##### Legend

- 1 Telescopic rod with adjuster via defined wells
  - 2 Components of the attachment mechanism for mounting the modular bracket on the frame
    - Mounting plate
    - Spring plate
  - 3 Mounting plates for mounting the LMS4x21 2D LiDAR sensors
-

**Mounting kit**

- The 2D LiDAR sensors are mounted above the conveying equipment using the mounting kit included in the scope of delivery.
- The mounting kit has a modular design and is preconfigured accordingly upon delivery.
- It consists of a width-adjustable telescopic tube with pre-mounted and pre-aligned mounting plates to hold the 2D LiDAR sensors.
- The telescopic tube is attached to the customer's frame via a pre-mounted attachment mechanism, consisting of a mounting plate and a spring plate.

**Installation steps**

- ▶ Assemble the profiles of the telescopic tube.
- ▶ Mount the telescopic rod on the frame.
- ↪ Fasten the 2D LiDAR sensor to the mounting plate.

**NOTE!** Adjustment after mounting is not required. The 2D LiDAR sensors have been correctly pre-aligned at the factory by adjusting the orientation of the mounting plates on the telescopic rod.

If an alternative attachment method is used (e.g., mounting the 2D LiDAR sensors on a hollow shaft), adjustment will be required.

**4.1.2 Assembling profiles of the telescopic tube**

Fig. 48: Assembling profiles of the telescopic tube

**Legend**

- |   |                                |
|---|--------------------------------|
| 1 | Main tube                      |
| 2 | Right and left telescopic tube |

**Mounting**

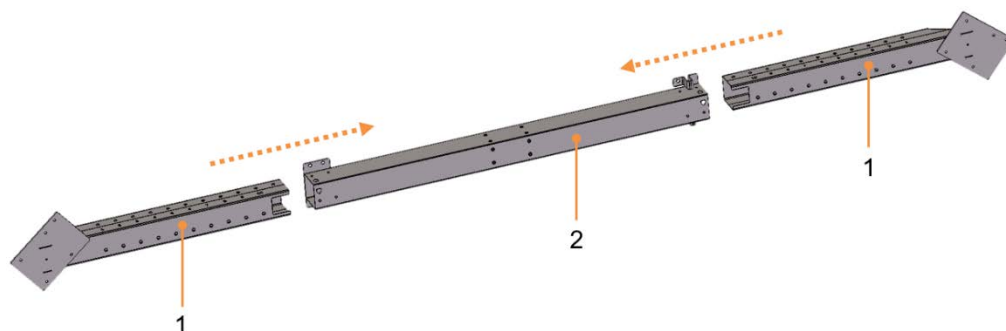
- ▶ Slide the right and left telescopic tubes into the main tube and fasten them with screws.
- ▶ Adjust the tube to the desired width with the help of the markings.

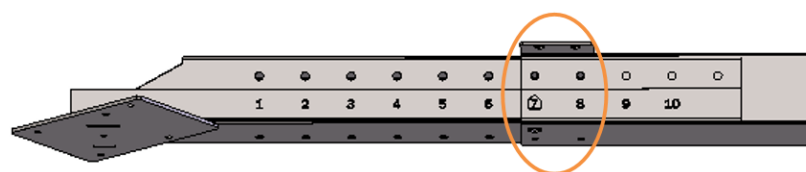

Fig. 49: Markings on the telescopic tube

## 4 MOUNTING

### 4.1.3 Mounting the telescopic tube on the frame

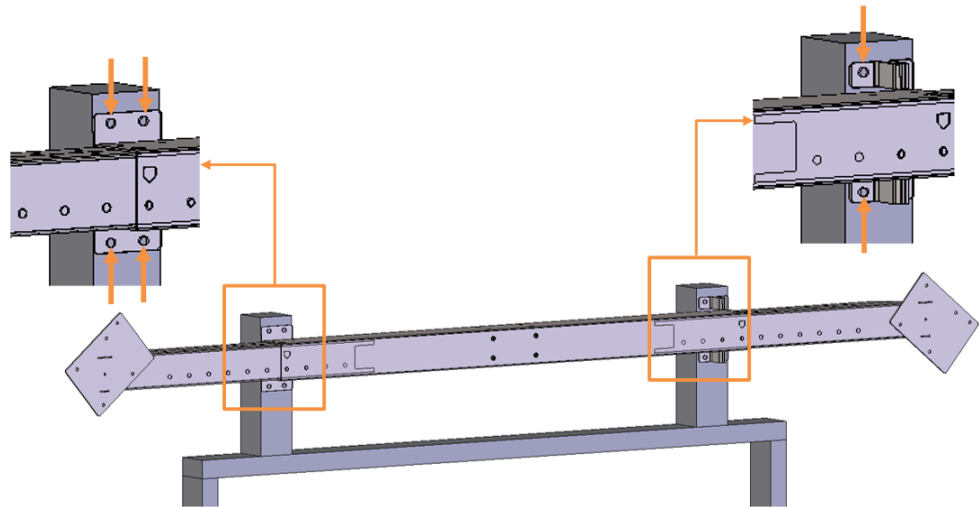

Fig. 50: Mounting the telescopic tube on the frame

#### Mounting

- ▶ Attach the telescopic tube to a profile using the mounting and spring plate that is pre-mounted on the base tube.

### 4.1.4 Fastening the 2D LiDAR sensors to the mounting plates

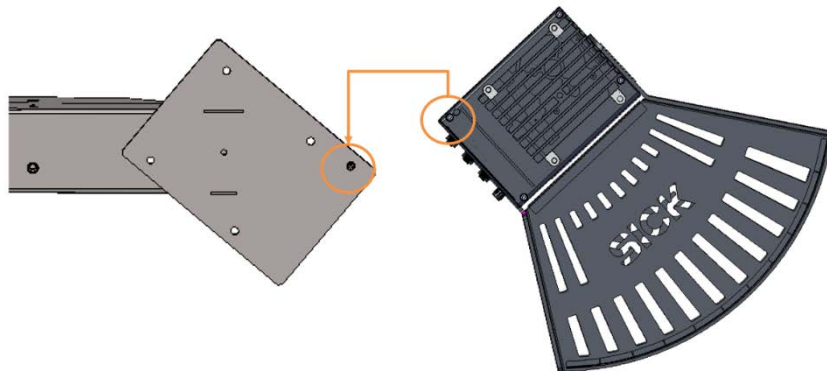

Fig. 51: Fastening the 2D LiDAR sensors to the mounting plates

#### Mounting

Each mounting plate has an injection bush on its rear side to accommodate the 2D LiDAR sensor. This coding prevents the device from being incorrectly rotated by 180° when mounted.

- ▶ Insert the injection bush of the mounting plate into the locating hole of the 2D LiDAR sensor.
- ▶ Press the device into place with one hand and screw the device to the mounting plate.
- ▶ Make sure that the device is securely screwed on.

## 4.2 Mounting the incremental encoder

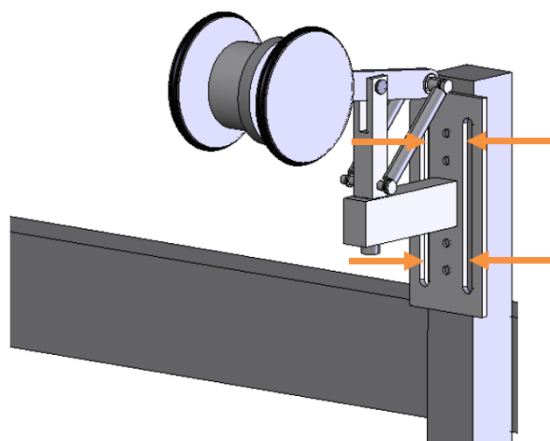

Fig. 52: Attaching the incremental encoder to the conveyor belt (optional)

### Mounting

- ▶ Install the incremental encoder directly on the conveyor belt.
- ▶ **NOTE!** Select an installation site near the circulation rollers or at the end of the belt, where the belt runs with little vibration.
- ▶ Tightly screw the incremental encoder to the mounting bracket. Align the incremental encoder so that it is plane-parallel with the reference plane (bottom side of conveyor belt).

## 4.3 Mounting the trigger photoelectric sensor

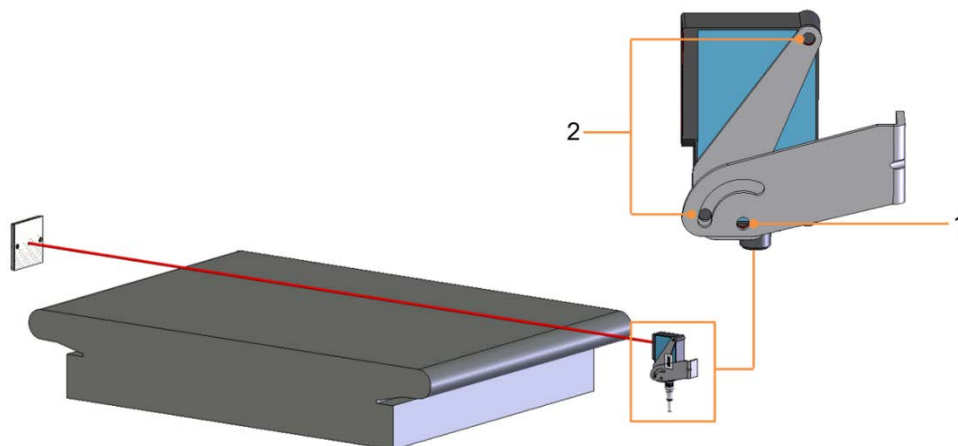

Fig. 53: Mounting the object detection photoelectric sensor

### Legend

- |   |   |
|---|---|
| 1 | Clinch stud. Secures the object detection photoelectric sensor to the mounting bracket. |
| 2 | M5 hexagon screws   |

### Mounting

- ▶ Mount the object detection photoelectric sensor on the mounting bracket using the two M5 hexagon screws.
- ▶ Secure the photoelectric sensor using the clinch stud.
- ▶ Align the photoelectric sensor correctly on the reflector. The reflector must be positioned within the beam path of the object detection photoelectric sensor.

### 4.4 Mounting the cabinet

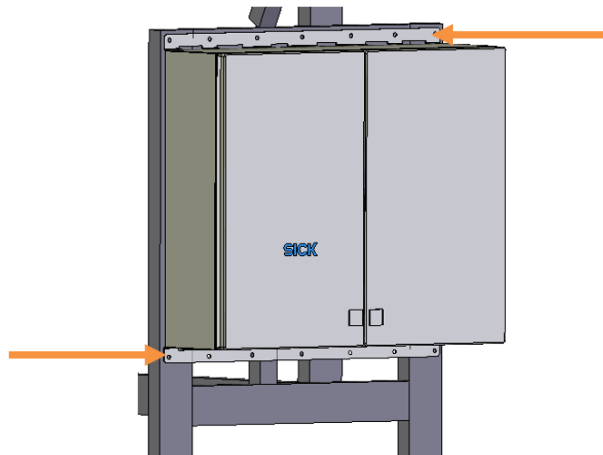

Fig. 54: Mounting the cabinet

---

**⚠ DANGER!**

**RISK OF INJURY FROM SUSPENDED LOADS**

The track and trace cabinet can weigh up to 36 kg depending on the variant.

Severe injury or death.

- ▶ Never stand under suspended loads.
- ▶ Pay close attention when lifting loads.
- ▶ Comply with lifting instructions to prevent injuries and accidents.
- ▶ Use suitable, undamaged lifting tools.
- ▶ Prevent the cabinet from tipping over during transport.
- ▶ Wear personal protective equipment (safety helmet, safety shoes).
- ▶ Obtain the assistance of at least one other person during mounting.
- ▶ Use the mounting accessories included with delivery.

---

**Prerequisites**

- ▶ The cabinet should generally be mounted as close to the measuring system as possible so that all connecting cables can be laid easily.
- ▶ Make sure that the cabinet doors can be easily opened.
- ▶ Ensure that the air inlets and outlets on the sides of the cabinet are not covered.

**NOTE!** To change the replaceable filter mats, the covers (louvered grills) can be opened downwards. The cabinet needs additional freely accessible work areas of approx. 140 mm on the left and right.

**Mounting**

A mounting kit in a minigrip bag is supplied with the cabinet.

- ▶ Insert the sliding nuts into the two aluminum transverse profiles as per the technical drawing and screw in the setscrews.
- ▶ Mount the track and trace cabinet above the two mounting rails and into the setscrews and secure the threaded connection with a washer and hexagonal nut.

**NOTE!** Use two people to lift the track and trace cabinet. Observe the ergonomic factors.

## 5 Electrical installation

All electrical work may only be performed by qualified persons.

- Qualified persons have the specialist training, skills, experience and knowledge of the relevant regulations and standards needed to be able to perform work assigned to them and to identify and avoid any potential dangers independently.
- Electricians have the professional training, skills, experience and knowledge of the relevant standards and provisions needed to work on electrical systems and to detect and avoid any potential dangers independently.

---

**⚠ DANGER!**

**HAZARDOUS ELECTRICAL VOLTAGE**

The system is supplied with line voltage. Risk of electrical shock. Contact will result in death, burns or shock.

- ▶ Electrical work may only be performed on the system by qualified specialist personnel.
- ▶ Interrupt the voltage supply.
- ▶ Check residual voltage on the system components.
- ▶ Use extra caution.
- ▶ Always connect equipotential bonding (earthing).
- ▶ Do not disconnect or remove the protective conductor.
- ▶ The voltage supply must be disconnected when attaching or detaching electrical connections.

---

**⚠ DANGER!**

**HAZARDOUS ELECTRICAL VOLTAGE**

An incorrect supply voltage may result in damage to the device.

- ▶ Only operate the cabinet with the specified supply voltage.
- ▶ All connected circuits must be designed as SELV circuits (in accordance with EN 60950 or ES1 EN 60368-1).

---

**NOTE!**

The connections of the VMS5200 system, which can be verified as legal for trade, may differ from the connections of the VMS4200 depending on the project.

## 5.1 Connection overview

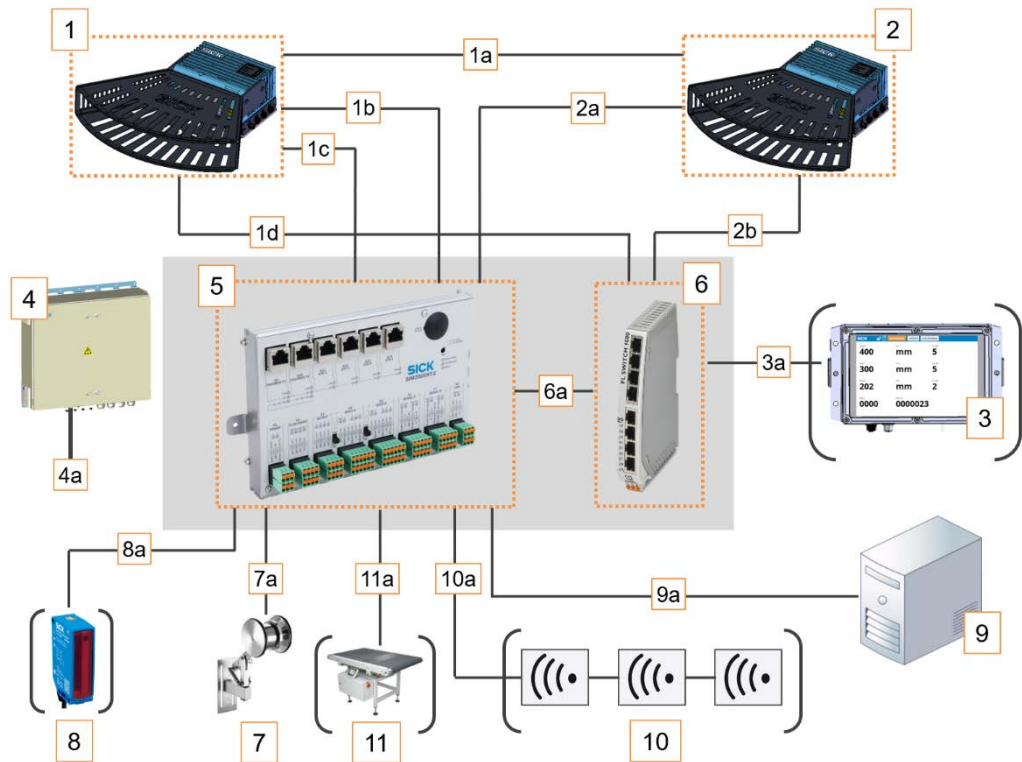

Fig. 55: Connection overview for the VMS4200/5200

### Legend

- 1** 2D LiDAR sensor (master)
- 1a CAN bus
- 1b Increment and synchronization
- 1c CAN bus
- 1d Ethernet
- 2** 2D LiDAR sensor (slave)
- 2a Synchronization
- 2b Ethernet
- 3** LFT display - VMS5200 only
- 3a Ethernet
- 4** Cabinet
- 4a Feed 100 ... 264 V AC / 50 ... 60 Hz
- 5** SIM2000-2 Prime controller
- 6** LFT Ethernet switch
- 6a Ethernet
- 7** Incremental encoder
- 7a Encoder signal
- 8** Photoelectric retro-reflective sensor (optional)
- 8a Trigger signal
- 9** Customer server
- 9a Data output via Ethernet, fieldbus, or serial connection
- 10** Reading station (optional)
- 10a CAN bus
- 11** Weighing station (optional)
- 11a Data connection



## 5.2 Connecting the voltage supply

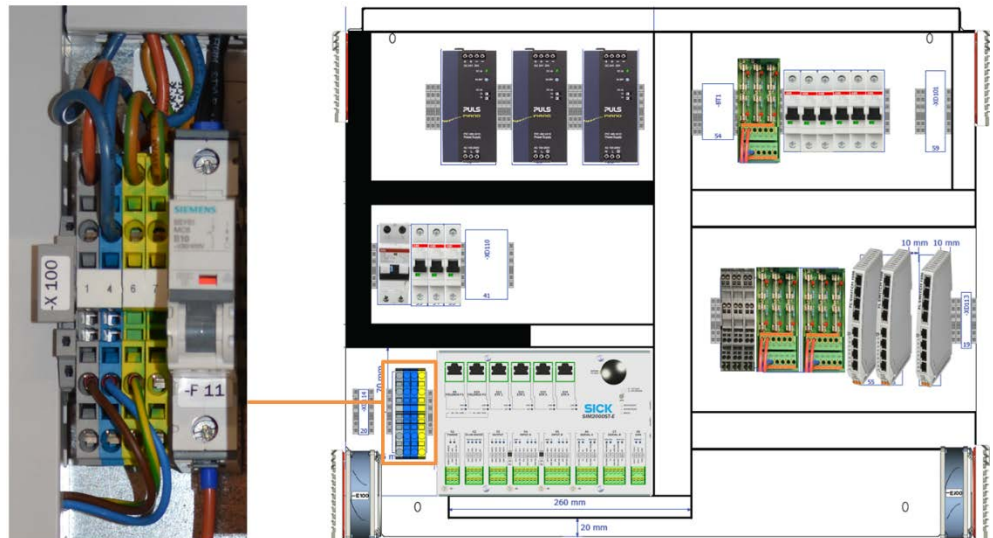

Fig. 56: Pin assignment of the -X100 terminal block in the cabinet

Terminal	Color	Signal	Function
-X100/1.1	Gray	L	Line voltage 100...264 V AC / 50...60 Hz (phase)
-X100/1.4	Blue	N	Line voltage 100 ... 264 V AC / 50 ... 60 Hz (neutral conductor)
-X100/1.6	Green-yellow	PE	Protective conductor

Tab. 9: Pin assignment of the -X100 terminal block in the cabinet

### NOTE!

- ▶ Make sure that cables are securely connected.  
No visible metal surfaces are permitted on the wires.
- ▶ Tighten the coupling nuts to provide strain relief on the cabinet. Doing so also maintains the enclosure rating.

## 5 ELECTRICAL INSTALLATION

### 5.3 Connection for LFT Ethernet switch (set up at the factory)



Fig. 57: Connection for LFT Ethernet switch (set up at the factory)

Voltage supply			
No.	Wire color	Area on fuse block	Connection
1	Dark blue	FC1	13 +
	Dark blue/Red	FC1	23 -
Ethernet connection controller			
No.	Connection on LFT Ethernet switch		Port on SIM2000-2 Prime
2	8		X14 ETH 4

Tab. 10: Connection for LFT Ethernet switch (set up at the factory)

5.4 Connection of 2D LiDAR sensors

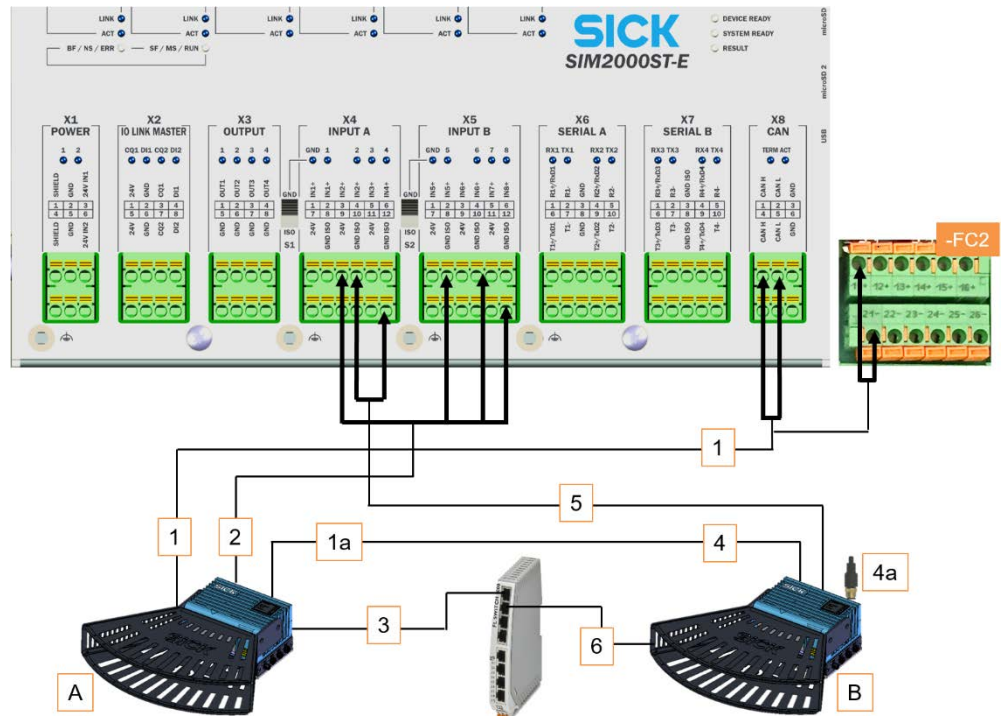

Fig. 58: Connection for the 2D LiDAR sensors on the SIM2000-2 Prime controller

Legend

- A LMS master
- B LMS slave

LMS master

CAN bus/voltage supply				
No.	Connection for the LMS4x21	Wire color	SIM2000-2 Prime terminal	Connection
1	POWER CAN_IN	White	X8 CAN	1 CAN_H
		Blue	X8 CAN	2 CAN_L
		Red	-FC2	11 +
		Black	-FC2	21 -
<b>Connection for the LMS4x21 (master)</b>			<b>Connection for the LMS4x21 (slave)</b>	
1a	POWER CAN OUT	POWER CAN IN		
Increment / synchronization				
No.	Connection for the LMS4x21	Wire color	SIM2000-2 Prime terminal	Connection
2	TACHO INPUT	Gray	X4 INPUT A	3 IN2+
		Black	X5 INPUT B	2 IN5+
		White	X5 INPUT B	4 IN6+
		Blue	X5 INPUT B	12 GND ISO (X5)
Ethernet				
No.	Connection for the LMS4x21	Port on LFT Ethernet switch		
3	Ethernet	1		

Tab. 11: Connection for LMS4x21 master

## 5 ELECTRICAL INSTALLATION

### LMS slave

<b>CAN</b>				
<b>No.</b>	<b>Connection for the LMS4x21 (slave)</b>	<b>Connection for the LMS4x21 (master)</b>		
4	POWER CAN IN	POWER CAN OUT		
4a	POWER CAN OUT - termination			
<b>Synchronization</b>				
<b>No.</b>	<b>Connection for the LMS4x21</b>	<b>Wire color</b>	<b>SIM2000-2 Prime terminal</b>	<b>Connection</b>
5	Sync	Blue	X4 INPUT A	4 IN2+
		Gray	X4 INPUT A	12 GND ISO (X4)
<b>Ethernet</b>				
<b>No.</b>	<b>Connection for the LMS4x21</b>	<b>Port on LFT Ethernet switch</b>		
6	Ethernet	2		

Tab. 12: Connection for LMS4x21 slave

5.5 Connection for the LFT display (set up at the factory)

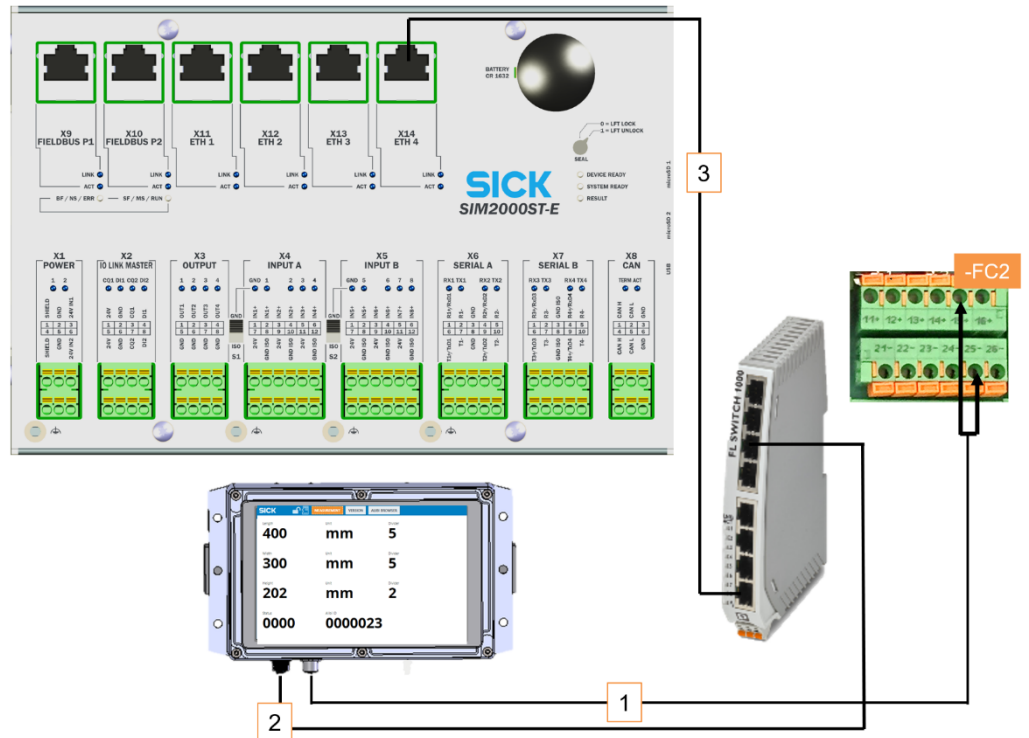

Fig. 59: Connection for the LFT display (set up at the factory)

Voltage supply			
No.	Wire color	Area on fuse block	Connection
1	Brown	FC2	15 +
	Blue	FC2	25 -
Ethernet data cable			
No.	Connection on LFT display		Port on LFT Ethernet switch
2	Ethernet (X118)		3
No.	Port on LFT Ethernet switch		Port on SIM2000-2 Prime
3	8		X14 ETH 4

Tab. 13: Connection for the LFT display (set up at the factory)

## 5.6 Connecting the incremental encoder

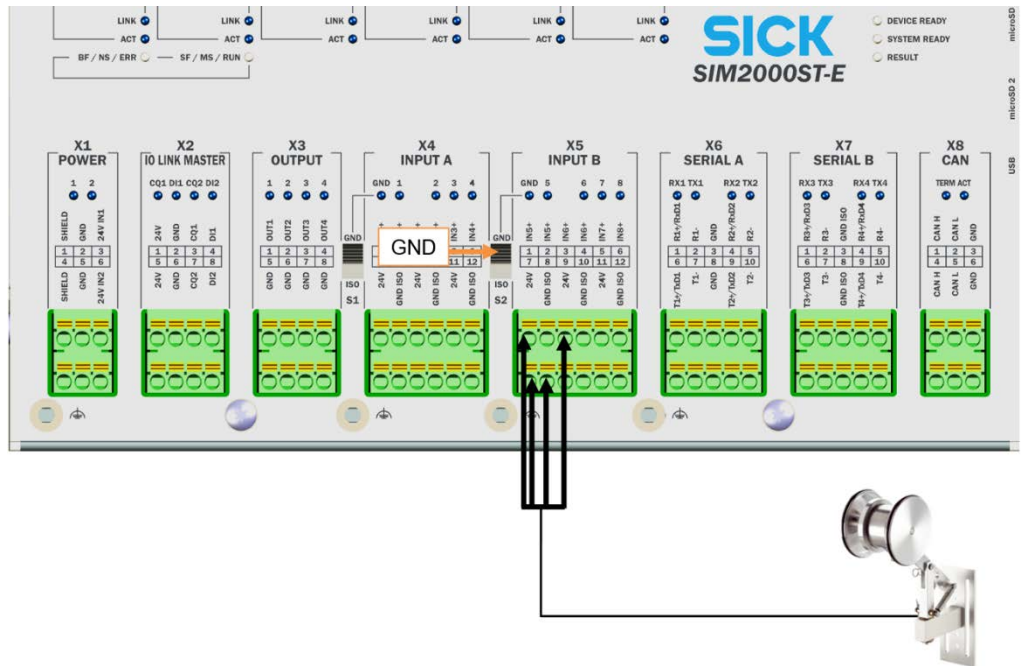

Fig. 60: Connection for the incremental encoder

Encoder signal		
Wire color	Terminal	Connection
Black	X5 INPUT B	1 IN5+
White	X5 INPUT B	3 IN6+
Brown	X5 INPUT B	7 24 V
Blue	X5 INPUT B	8 GND ISO (X5)

Tab. 14: Connection for the incremental encoder

### External encoder signal

- If the encoder signal comes from an external source, the switching input can be connected to the controller in a volt-free manner.
- In this case, the DIP switch **S2** must be set to **GND\_ISO (X5)**.
- The connection with terminal 7 (24 V) can be omitted.

## 5.7 Connection for the photoelectric retro-reflective sensor (optional)

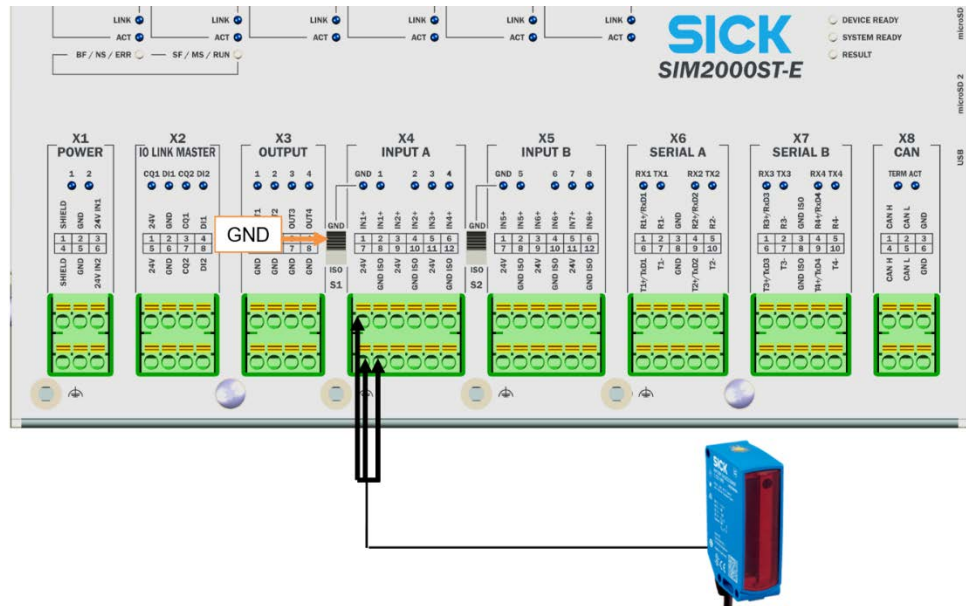

Fig. 61: Connection for the photoelectric retro-reflective sensor (optional)

Trigger signal		
Wire color	Terminal	Connection
Black	X4 INPUT A	1 IN1+
Brown	X4 INPUT A	7 24 V
Blue	X4 INPUT A	8 GND ISO (X4)

Tab. 15: Connection for the photoelectric sensor trigger (optional)

### External trigger signal

- If the trigger signal comes from an external source, the switching input can be connected to the controller in a volt-free manner.
- In this case, the DIP switch **S1** must be set to **GND\_ISO (X4)**.
- The connection with terminal 7 (24 V) can be omitted.

## 5.8 Connecting the customer interface

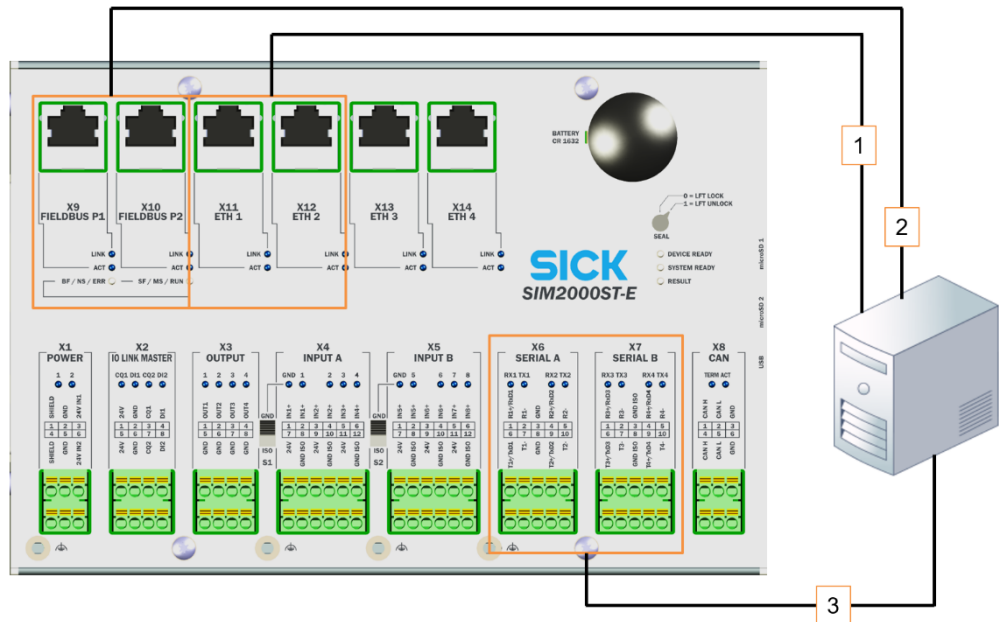

Fig. 62: Connection to the customer network

### Data cable

The measuring and reading data is issued to the customer system in one of the following data issue formats:

- Ethernet
- Fieldbus
- RS-232 / RS-422

### Connection

	Terminal / Port	Connection
1	X11 ETH1, X12, ETH 2, X13 ETH3	Ethernet
2	X9 FIELDBUS P1, X10 FIELDBUS P12	Fieldbus
3	X6 SERIAL A/X7 SERIAL B	RS-232 / RS-422

**NOTE!** If a reading station has been integrated, the image information processed by the camera systems can be transmitted to a customer server via a separate Ethernet or Gbit interface.



## 6 Commissioning

Commissioning may only be performed by qualified persons.

- Qualified persons have the specialist training, skills, experience and knowledge of the relevant regulations and standards needed to be able to perform work assigned to them and to identify and avoid any potential dangers independently.
- Electricians have the professional training, skills, experience and knowledge of the relevant standards and provisions needed to work on electrical systems and to detect and avoid any potential dangers independently.

### Notes

- Initial commissioning of the multi-dimensional measurement system is performed by the manufacturer.
- All of the system functions are set up by configuring the measuring conditions on-site.
- Initial commissioning by the manufacturer is not covered in these supplementary operating instructions.

### 6.1 Switching on the system

- ▶ Establish the supply of voltage to the devices via the power supply units in the TTC100-2.

All system components automatically start up.

#### Internal check for operational readiness

- Self-diagnosis is performed to check the operational readiness of the devices.
- During the power-up cycle, the status indicators show the device status.

**NOTE!** The system in which the multi-dimensional measurement system is integrated is put into operation via the higher-level control.

### 6.2 Configuring the system with SOPAS



The measurement system is adjusted by configuring the measuring conditions on site. This enables measurement, analysis, and output properties to be parameterized as required.

The SOPAS ET configuration software (included) allows interactive configuration. You can use the software to parameterize and test the properties, analysis behavior, and output properties of the system as required.

#### 6.2.1 Connecting the configuration PC

The SOPAS configuration software is installed on a computer, which is connected to a free port on an Ethernet switch of the TTC100-2 via an Ethernet cable.

The configuration software is available for download from the SICK home page.



Fig. 63: Establishing the configuration PC – SIM2000-2 Prime controller connection

- Using an Ethernet cable, connect the configuration PC to a free Ethernet port on an Ethernet switch of the TTC100-2.

## 6.2.2 Installing SOPAS

- ▶ Download the latest version of SOPAS ET from [www.sick.com](http://www.sick.com) and install it on the configuration PC.
- ▶ Start the installation by double-clicking the **setup.exe** file.



- ▶ Click on **Installation**.
- ▶ Click **OK** to select a user language for the wizard. The setup wizard opens.



- ✓ Perform the installation.

## 6 COMMISSIONING

### 6.2.3 Assigning IP addresses

**Overview** IP addresses in the delivery state:

Component	Default IP address
SIM2000-2 Prime controller	192.168.0.1
LMS4x21 master	192.168.0.1
LMS4x21 slave	192.168.0.1

Tab. 16: Default IP addresses of device components

Recommended CAN and IP address assignments:

Component	CAN	TCP/IP
SIM2000-2 Prime controller	32	192.168.0.32
LMS4x21 master	25	192.168.0.25
LMS4x21 slave	26	192.168.0.26

Tab. 17: Recommended addresses of device components

**Procedure** As the IP addresses are the same, the IP addresses must be assigned for each device individually.

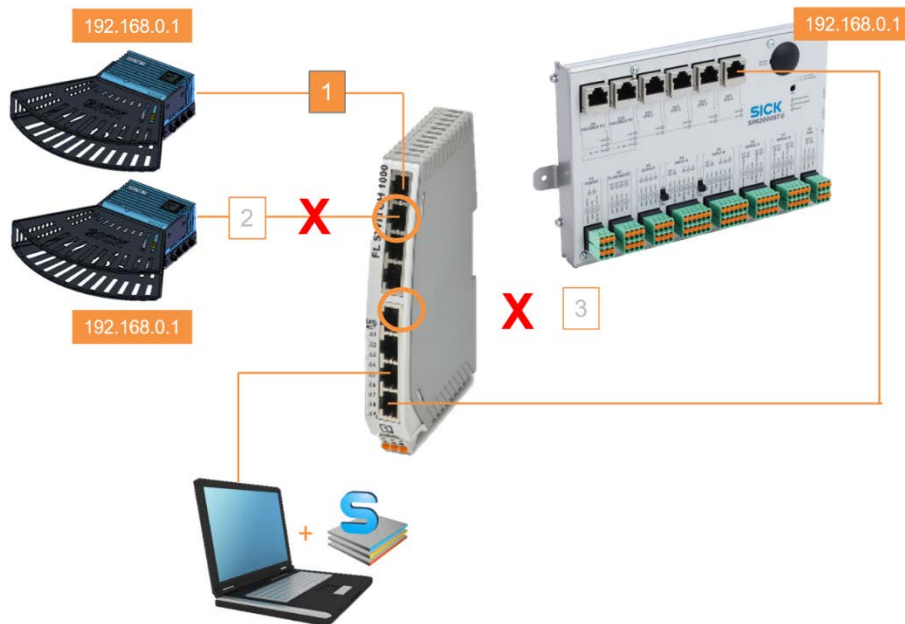
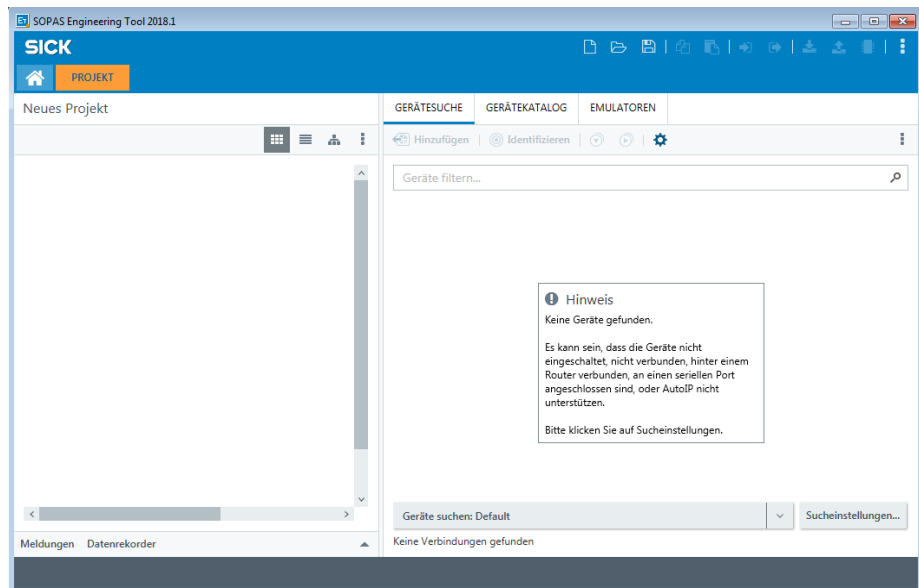

Fig. 64: Procedure for assigning IP addresses

- ▶ Make sure that the 2D LiDAR sensors are mounted correctly and electrically connected.
- ▶ Detach all Ethernet connections from the LFT Ethernet switch so that only one 2D LiDAR sensor is connected to the LFT Ethernet switch.
- ▶ Connect the configuration PC to a free port on the LFT Ethernet switch.
- ▶ Make sure that the configuration PC is in the number range of the connected device components.
- ✓ If it is not, change the IP address of the configuration PC accordingly.

**Launching SOPAS**

- ▶ Start SOPAS using the desktop icon or the Windows Start menu.  
A new **project** is automatically created in SOPAS ET. One or more devices are combined and edited in a single project.



**Adjusting the IP address of the first LMS4x21 Starting the device search**

- ▶ Change the IP address of the configuration PC to the address range of the connected 2D LiDAR sensors.
- ▶ Click on the **Search settings** button. The Connection Wizard helps you establish a connection to a connected device.
- ▶ Select the **Search using device family** option and click **Next** to confirm.

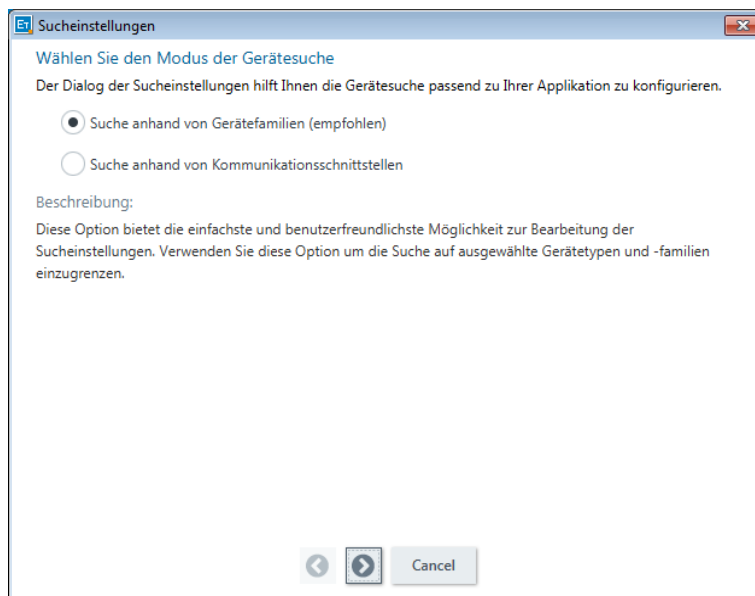

- Limit the list to the LMS4000 family and click **Next** to confirm.

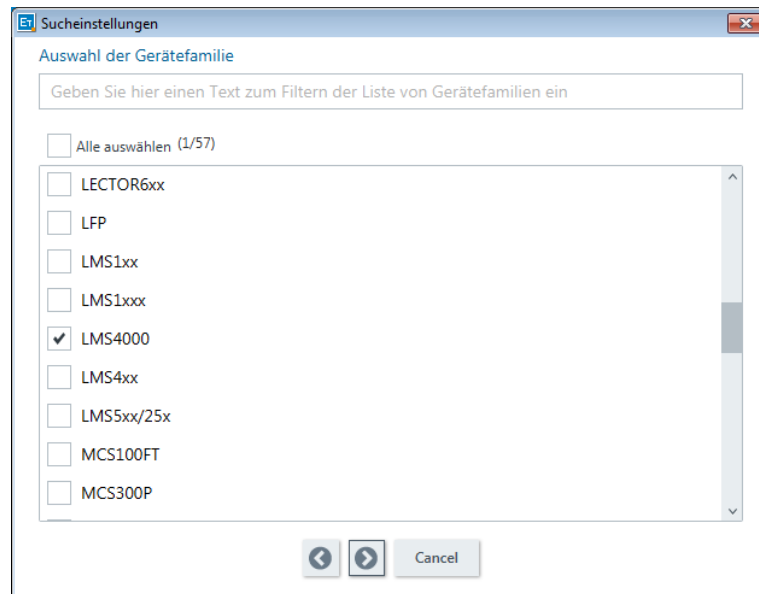

- ▶ Click **Next** to confirm each of the configured search settings, and click **Finish** to complete.

If the number ranges for the configuration PC and the device correspond, then the connected 2D LiDAR sensor is detected and displayed in the device list on the right-hand side.

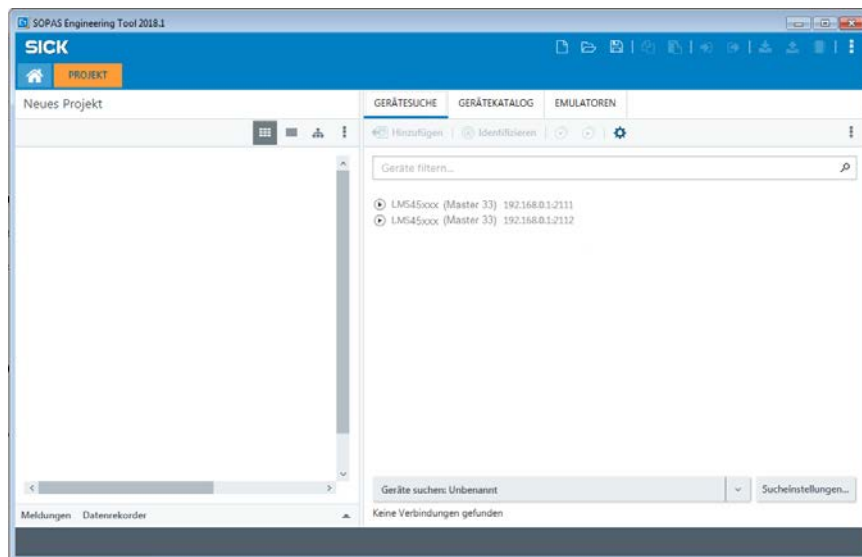

**NOTE!** The 2D LiDAR sensor uses two ports (like all SICK devices). Ports are part of the network address and can be used to establish various connections between the devices. Port **2112** is freely parameterizable but port **2111** is a fixed port for outputting data. It is used for device configuration.

### Transferring a device to a SOPAS project

- ▶ Select the device with port number **2111**.
- ▶ Click on **Add**. The transferred device is displayed in the left-hand window as a **tile** along with its default IP address.

**NOTE!** Where applicable, a message window will appear indicating that the device driver for the 2D LiDAR sensor is not yet known in the SOPAS project.

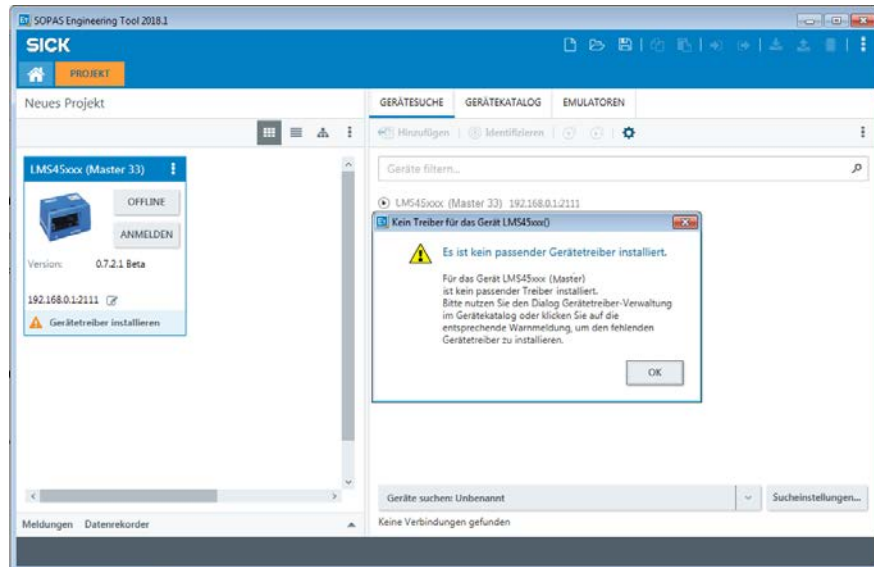

### Loading device drivers into the SOPAS project

- ▶ Confirm the message with **OK**.
- ▶ Click **Install device driver** in the tile.
- ▶ To install the device driver, select the **Upload from device** option.

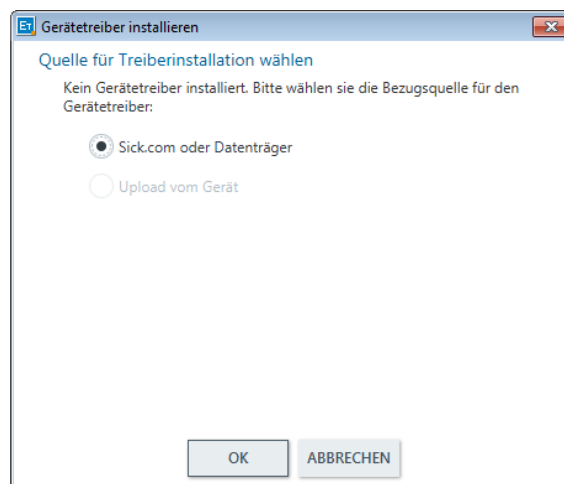

- ✓ Click **OK** to confirm. The device drivers are installed. The 2D LiDAR sensor will now be detected by the configuration PC.

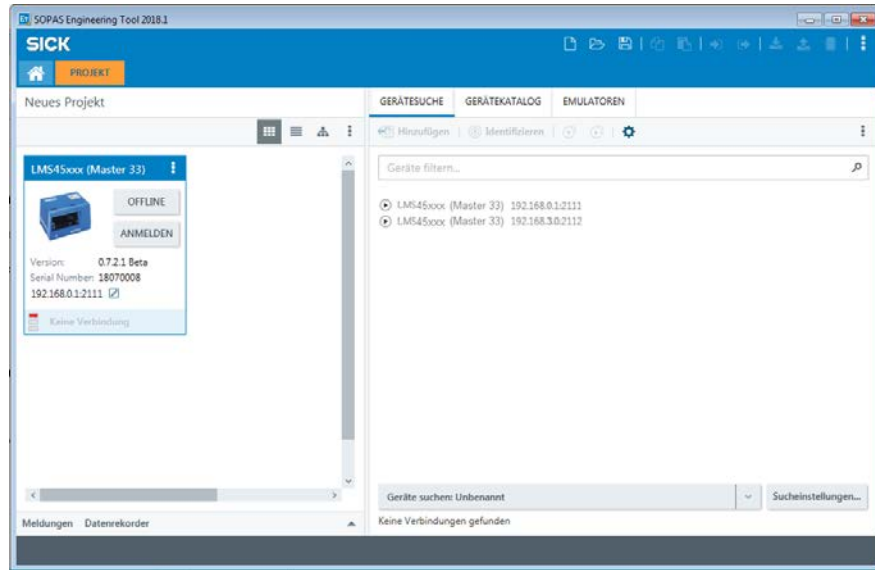

### Changing the IP address



- ▶ In the device tile, click the pen icon next to the IP address.
- ▶ In the **TCP/IP settings** window, select the **Use the following IP settings** option and define the IP address that is to be used to access the 2D LiDAR sensor in the sensor network.

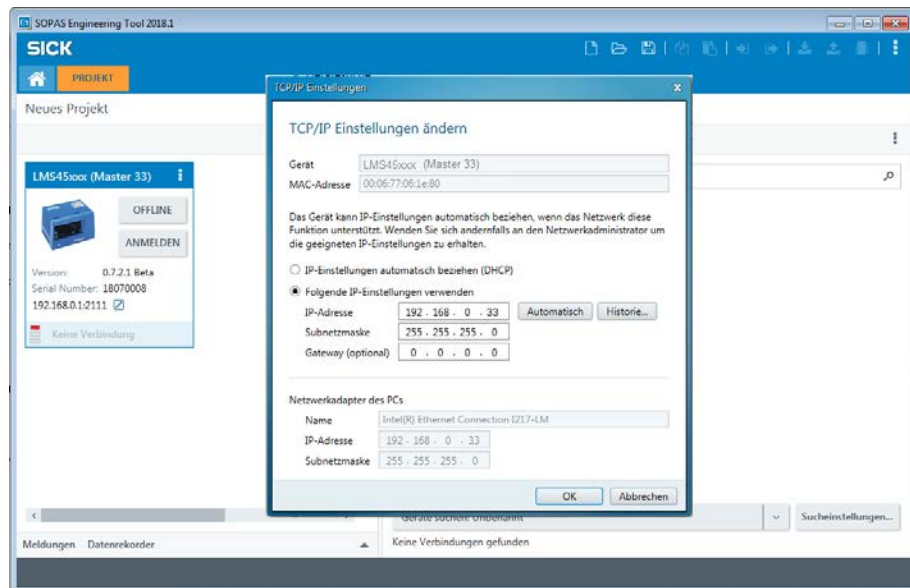

- ✓ Click **OK** to confirm the entry. The altered IP address is displayed in the device tile.  
**NOTE!** If the configuration PC and the 2D LiDAR sensor are still in the same number range, the connection to the altered IP address of the 2D LiDAR sensor can be established directly.



**Procedure in the event of deviating address ranges**

- ▶ Change the IP address of the configuration PC to the altered address range of the relevant device.
- ▶ In the title bar of the device tile, click on the icon with the three dots and select **Remove device entry**.
- ▶ Perform a new device search in SOPAS. The device is found with its new IP address and displayed in the device list.
- ▶ Add the device with port 2111 to the SOPAS project.

**Configuring the IP address of the second LMS4x21**

- ▶ Connect the second LMS4x21 to a free port on the LFT Ethernet switch.
  - NOTE!** As the default IP address for the first 2D LiDAR sensor was changed, this device can remain connected via Ethernet.
- ▶ Perform a device search and change the default IP address as described.
  - NOTE!** It is not necessary to install the device driver for the LMS4x21. This was already completed when the first 2D LiDAR sensor was added.

**Changing the IP address of the SIM2000-2 Prime controller**

- ▶ Change the IP address of the configuration PC to the address range of the SIM2000-2 Prime controller.
- ▶ Perform a device search and change the default IP address as described.
- ✓ The SIM2000-2 Prime controller and 2D LiDAR sensor, along with their device tiles, are now included in the SOPAS project.

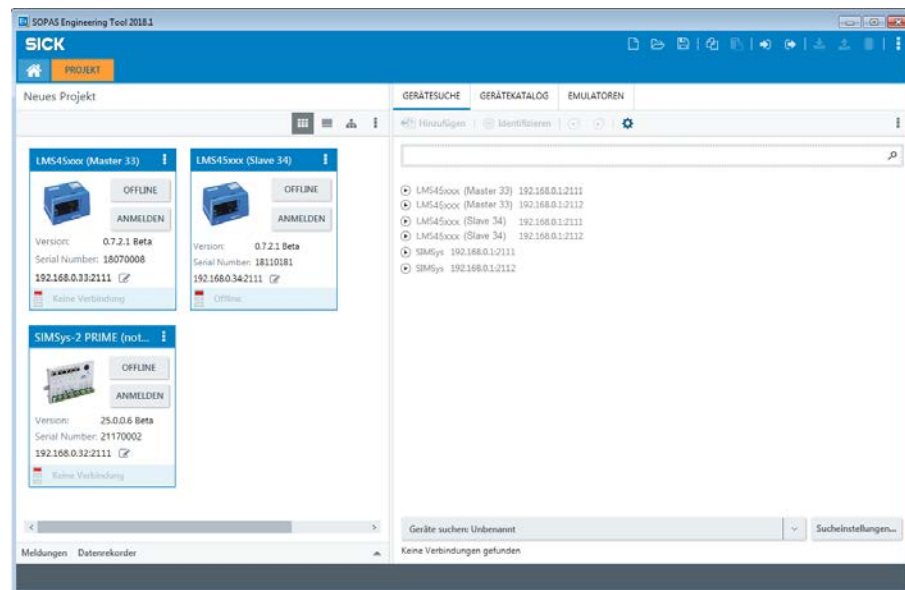

### 6.2.4 Opening the configuration interface

#### Bringing the device online

- ▶ Click the **Offline** button in the tile (opens the LMS4x21 in this example).
- ▶ Synchronize the 2D LiDAR sensor's device data with the device data of the SOPAS project. To do this, click on **Read parameters**.

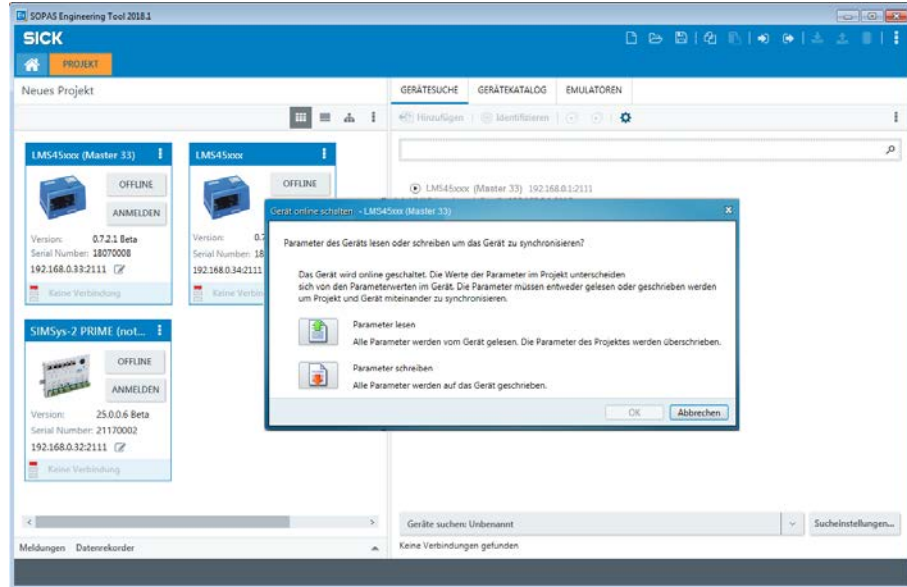

- ▶ The standard parameters are transmitted from the 2D LiDAR sensor into the SOPAS project. These parameters are then adapted to the requirements of the 2D LiDAR sensor in SOPAS.
- ✓ **Online** appears in the tile. The LED lights up green.

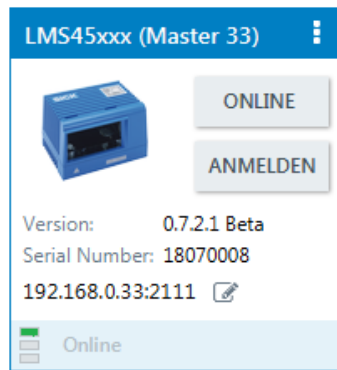

**Configuration interface**

- ▶ Double-click on the device tile.
- All configurable parameters of the 2D LiDAR sensor are compiled together in a corresponding device description for the SOPAS configuration software.
- ▶ Use the tabs to open the functional areas of the configuration.

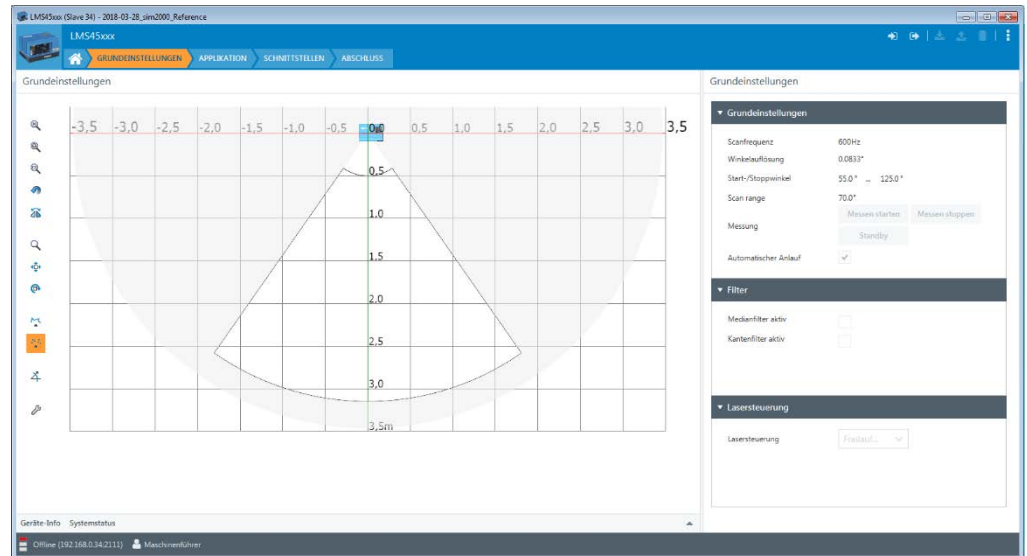

**6.2.5 Logging on to device**



- ▶ In the SOPAS toolbar, click on the icon with the three dots and select **Device** → **Login**.

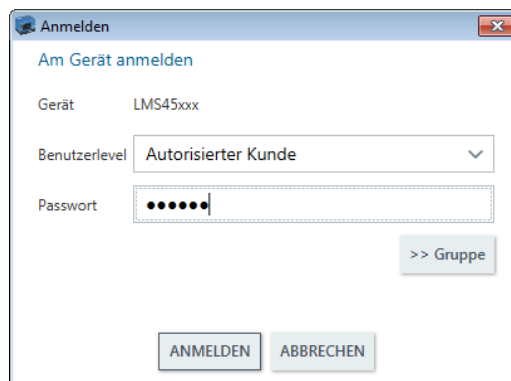

- ▶ Select the **Authorized client** user level and enter the default password **client**.
- ✓ Click **LOGIN** to confirm.
- The parameters that were previously grayed out on the tabs are now accessible.

### 6.2.6 Saving the parameters permanently

All parameters entered in SOPAS are transmitted to and executed on the connected SIM200-2 Prime controller with the **Immediate download** option. However, the data is only saved **temporarily** in the SIM200-2 Prime controller.

#### Saving the configuration in the non-volatile memory



- ▶ Click on the **Save parameters permanently** icon in the SOPAS toolbar.

The configuration is transferred to the SIM200-2 Prime controller and saved there permanently. This configuration is loaded whenever the controller is restarted.

#### Saving the configuration on the computer



- ▶ Click on the **Save project** button in the project window SOPAS toolbar.

- ▶ Choose a directory and file name and then confirm.

The settings are saved on the computer in a configuration file with the format **\*.spr**.

**NOTE!** The settings within this file can be loaded subsequently (if required) and transmitted to the SIM200-2 Prime controller.

## 7 Maintenance and repair

Maintenance and repair measures may only be carried out by qualified persons.

- Qualified persons have the specialist training, skills, experience and knowledge of the relevant regulations and standards needed to be able to perform work assigned to them and to identify and avoid any potential dangers independently.
- Electricians have the professional training, skills, experience and knowledge of the relevant standards and provisions needed to work on electrical systems and to detect and avoid any potential dangers independently.

Device	Maintenance task	Interval*	Type
LMS4x21	Cleaning the front screen	1x/month	Trained personnel
Incremental encoder	Visually inspect the incremental encoder for signs of measuring wheel wear and check the measuring wheel/conveyor belt contact	1x/month	Trained personnel
Photoelectric retro-reflective sensor (optional)	Cleaning the light emission and reflector Visually inspect the object detection photoelectric sensor and reflector for rotation that may have occurred as a result of touching or the like	4x/year	Trained personnel
Cabinet	Cleaning the air inlets and outlets Replacing the filter mat in the air inlets and outlets	4x/year	Trained personnel
General information	Visual monitoring for contamination	Daily	Trained personnel
	Optical monitoring of conveying equipment for foreign bodies/damage	Daily	Trained personnel
	Control measurements with test objects to check the measurement accuracy of the multi-dimensional measurement system	Whenever the system is started	Trained personnel
	Visual electrical cabling check and as well as visual inspection of wiring for damage	1x/year	Trained personnel
	Maintenance of the individual components	2x/year	Service technicians
	Checking the complete system including measurement system/reading performance/image quality/reading range	1x/year	Service technicians
* The intervals depend on the ambient conditions and degree of contamination. In addition, the intervals must be defined according to how important they are for the customer process.			

Tab. 18: Maintenance intervals

## 7 MAINTENANCE AND REPAIR

---

### 7.1 Monitoring and cleaning work

#### 7.1.1 Control measurements

- ▶ Ensure proper functioning of the multi-dimensional measurement system by means of regular controls.
- ▶ To do so, check the measurement accuracy of the multi-dimensional measurement system using defined test objects.
- ▶ If any unexpected deviations are found, check the multi-dimensional measurement system for mechanical damage.
- ▶ Should the multi-dimensional measurement system show signs of mechanical damage, contact SICK Service.

#### Operational check of the volume measurement

- ▶ Place the reference object **in a centered position** on a conveyor element.  
**NOTE!** The 2D LiDAR sensors need to be able to detect the entire reference object when it passes the laser line.
- ▶ Make sure that the reference object does not change its spatial position when passing the laser line.

#### 7.1.2 Visual inspection

#### Visual inspection of the conveying equipment

- ▶ Regularly check the conveying equipment for damage or contamination.
- ▶ Replace any damaged belt elements immediately.

#### Visual inspection of the cables

- ▶ Check the electrical installation regularly.
- ▶ Make sure that all cable connections are secure.
- ▶ Replace any damaged connecting cables immediately.

### 7.1.3 Cleaning the 2D LiDAR sensors

Contamination on the optical boundary surface of the 2D LiDAR sensor can impair the measuring behavior of the device.

#### Cleaning the front screen



Fig. 65: Cleaning the front screen of the 2D LiDAR sensor

- ▶ Switch off the device during cleaning.
- ▶ Remove dust from the front screen using a soft, clean brush.
- ▶ Then wipe the front screen with a clean, damp, lint-free cloth. Use a mild, anti-static lens cleaning fluid if necessary.

---

#### **⚠ WARNING!**

##### **HAZARDOUS LASER RADIATION**

The 2D LiDAR sensors of the VMS4200/5200 use a class 2 laser.

The human eye is not at risk when briefly exposed to the radiation for up to 0.25 seconds. Exposure to the laser beam for longer periods of time may cause damage to the retina. The laser radiation is harmless to human skin.

- ▶ Never look directly into the laser beam.
- ▶ Never point the laser beam at people's eyes.
- ▶ During commissioning or maintenance work, suitable eye protection must be worn.
- ▶ Avoid laser beam reflection caused by reflective surfaces. In particular during mounting and alignment work.
- ▶ Do not open the housing.
- ▶ Current national regulations regarding laser protection must be observed.

---

#### **⚠ CAUTION!**

##### **REDUCED READING PERFORMANCE DUE TO SCRATCHES OR STREAKS ON THE OPTICAL BOUNDARY SURFACE**

The optical output is weakened by scratches and streaks on the optical boundary surface.

- ▶ Do not use aggressive cleaning agents.
  - ▶ Do not use abrasive cleaning agents.
  - ▶ Avoid any movements that could cause scratches or abrasions on the front screen.
-

## 7 MAINTENANCE AND REPAIR

---

### 7.1.4 Cleaning the deflector mirror

In system setups with deflector mirror, we suggest the following cleaning:

- The external deflector mirror is a front surface mirror. That means that cleaning it affects the optical effective area itself.
- Only touch the reflector surface if absolutely necessary, and then only partially, if possible.

---

**⚠ WARNING!**

**DAMAGE TO THE OPTICAL EFFECTIVE AREA OF THE DEFLECTOR MIRROR**

Using the wrong cleaning technique or aggressive cleaning agents can damage the deflector mirror, thus impairing the reading performance of the camera system.

- ▶ That is why you should not clean the deflector mirror unless it is necessary.
  - ▶ Only touch the reflective surface when this is absolutely necessary (e.g., if it is very contaminated).
  - ▶ Never touch the entire reflective surface.
  - ▶ Do not use oily compressed air from a can.
  - ▶ Do not wipe the mirror with a towel as this could cause irreversible scratches.
- 

**Removing dust and loose particles**

- ▶ Carefully blow away dust and loose dirt particles with clean, oil-free air.

**Removing solid particles**

- ▶ Carefully remove any solid particles using a camel-hair brush previously degreased with acetone. Do not apply any acetone directly to the mirror surface.

The camel-hair brush must have the following properties:

- Camel-hair brush for photographic purposes.
- Natural hair to prevent static charge.
- Suitability for cleaning optical surfaces, lenses, negatives.

**Intensively cleaning the deflector mirror**

- ▶ Fill a clean plastic spray bottle with distilled water.
- ▶ Spray the mirror surface uniformly with distilled water. Hold the mirror at an angle so the distilled water can drip off.
- ▶ Let the mirror dry. Do not wipe the mirror dry!

**Removing grease deposits**

- ▶ Spray the affected areas with a household glass cleaner.
- ▶ Carefully wipe paper tissue (recommendation: "Kleenex") over the affected area. Only apply light pressure to the mirror. Do not scour!
- ▶ Let the mirror dry. Do not wipe the mirror dry!



7.1.5 Checking the incremental encoder components

The measuring wheel of the incremental encoder must have direct and steady contact with the conveyor belt and must turn without any slipping.

Contamination on the measuring wheel or damaged rubber rings can cause faulty behavior of the incremental encoder.

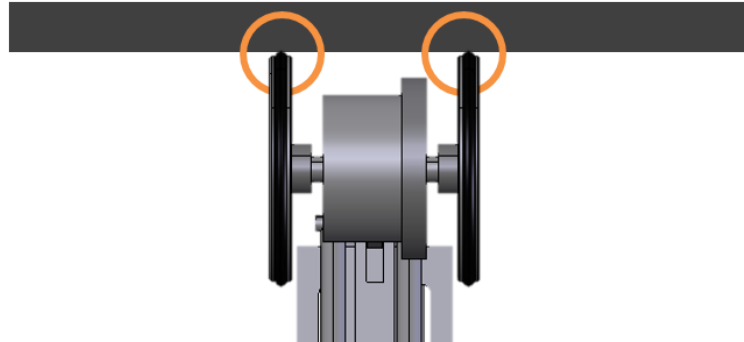

Fig. 66: Visual inspection of the incremental encoder (DFV60 in this example)

Maintenance

- ▶ Remove any contamination on the measuring wheel of the incremental encoder.
- ▶ Replace damaged rubber rings.
- ▶ Check the wear of the measuring wheel.

**NOTE!** If it is so badly worn that contact with the conveyor belt is impaired, the incremental encoder must be replaced (see below).

7.1.6 Cleaning the photoelectric retro-reflective sensor

Contamination on the photoelectric retro-reflective sensor can cause faulty switching behavior.

- ▶ Remove contamination from the optically active surfaces of the sensors.

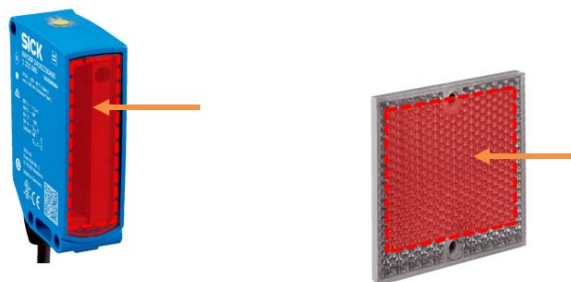

Fig. 67: Cleaning the optical surfaces of the photoelectric retro-reflective sensor

- ▶ Check that the photoelectric sensor and reflector are aligned correctly at regular intervals.

## 7 MAINTENANCE AND REPAIR

### 7.1.7 Cleaning the cabinet

The cabinet features an integrated fan to ensure that cabinet components are adequately cooled.

#### Cleaning

- ▶ Air inlets and outlets on the cabinet should be cleaned regularly with a brush.

---

**⚠ WARNING!**

**RISK OF DAMAGE TO ELECTRONIC DEVICES**

- ▶ Never use compressed air for cleaning!
  - ▶ Only knock the dirt off the ventilation grilles or clean them with a brush.
  - ▶ Never wet-clean the grilles.
- 

#### Replacing filter mats

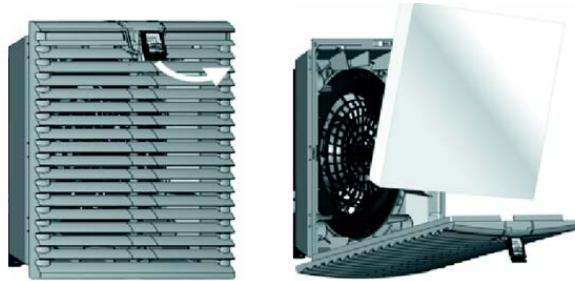

Fig. 68: Replacing the filters at the air inlets and outlets of the cabinet

- ▶ Regularly check and, if necessary, replace the filter mats behind the covers for the air inlets and outlets.
- ▶ Remove the covers from the air inlets and outlets. To do so, insert your finger into the semi-circular recess in the cover.
- ▶ Carefully remove the cover from the front.
- ▶ Remove old filter mats and replace them with new ones.
- ✓ Reattach the covers the right way up and press them down until they click into place.

7.2 Replacing components

7.2.1 Replacing the 2D LiDAR sensor

Replacement device

Part no.	Meaning
1094132	LMS4421R-16000 2D LiDAR sensor with pre-mounted laser protective cover for the VMS4200
1086802	LMS4521R-16000 2D LiDAR sensor with pre-mounted laser protective cover for the VMS5200

**⚠ WARNING**

**Loss of MID conformity after replacing a component**

The 2D LiDAR sensors are part of the legal for trade system.

When a component is replaced, the VMS5200 loses its legal-for-trade approval.

- ▶ After replacing a component, contact the manufacturer.
- ▶ The manufacturer will arrange for the system to be reverified after the replacement of a component.

**⚠ WARNING!**

**HAZARDOUS LASER RADIATION**

The 2D LiDAR sensors of the VMS4200/5200 use a class 2 laser.

The human eye is not at risk when briefly exposed to the radiation for up to 0.25 seconds. Exposure to the laser beam for longer periods of time may cause damage to the retina. The laser radiation is harmless to human skin.

- ▶ Never look directly into the laser beam.
- ▶ Never point the laser beam at people’s eyes.
- ▶ During commissioning or maintenance work, suitable eye protection must be worn.
- ▶ Avoid laser beam reflection caused by reflective surfaces. In particular during mounting and alignment work.
- ▶ Do not open the housing.
- ▶ Current national regulations regarding laser protection must be observed.

### Removing a defective device

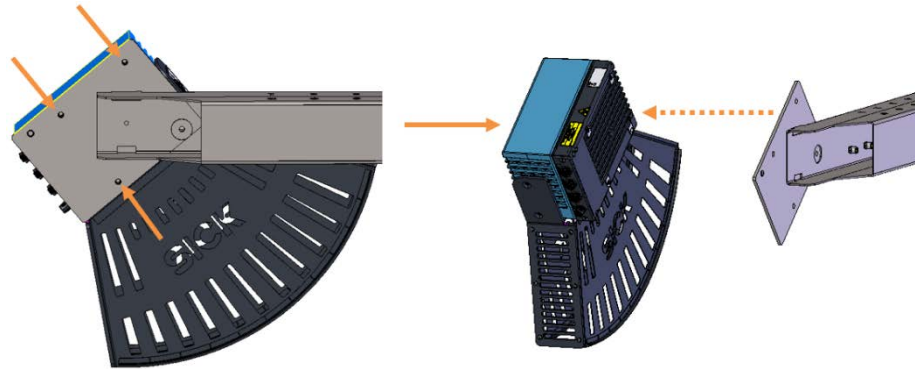

Fig. 69: Removing the 2D LiDAR sensors from the mounting plates

- ▶ Undo and remove the three M6 fixing screws at the rear of the mounting plate.
  - NOTE!** When loosening the last screw, press the 2D LiDAR sensor against the bracket with one hand to hold the device in place.
- ▶ Remove the defective 2D LiDAR sensor from the bracket. The mounting plate remains mounted on the telescopic tube.

### Mounting the replacement device

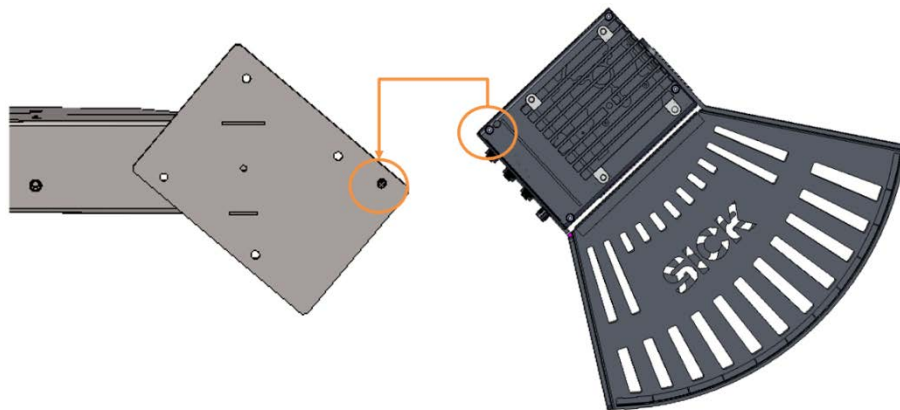

Fig. 70: Dowel pins and locating holes

- ▶ Press the device into place with one hand and screw the device to the mounting plate.
- ▶ Make sure that the device is securely screwed on.
- ▶ Screw the connecting cables back on.
- ▶ Switch the voltage supply back on.
- ▶ Check that the status LED lights up green after approximately 40 seconds.

### Test run

- ▶ Conduct a test run and check whether the multi-dimensional measurement system is providing plausible measurement results.
  - NOTE!** It may be necessary to recalibrate the exchanged 2D LiDAR sensor using SOPAS.

### Restoring MID conformity

- ▶ After replacing a component, contact the manufacturer.
- ▶ The manufacturer will arrange for the system to be reverified after the replacement of a component.

## 7.2.2 Replacing the deflector mirror

**NOTE!** Do not remove protective foil of the deflector mirror until mounting is complete.

---

### **⚠ WARNING**

#### **Loss of MID conformity after replacing a component**

The deflector mirror is part of the legal for trade system.

When a component is replaced, the VMS5200 loses its legal-for-trade approval.

- ▶ After replacing a component, contact the manufacturer.
  - ▶ The manufacturer will arrange for the system to be reverified after the replacement of a component.
- 

### Removing a defective deflector mirror

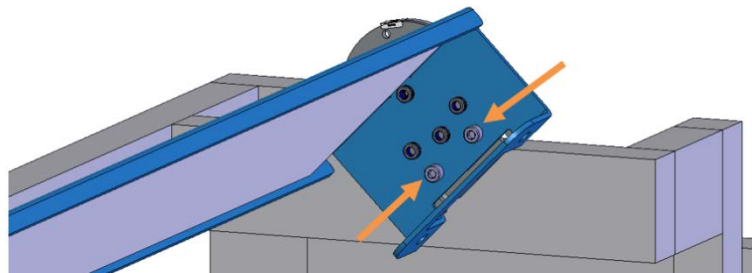

Fig. 71: Deflector mirror removal

- ▶ Mark the installed position of the deflector mirror in the mounted state (e.g., using the hole pattern).
- ▶ Undo and remove the two fixing screws on the two 180° mounting brackets.
  - NOTE!** For this, the deflector mirror needs to be held and secured against falling by a second person.
- ✓ Remove the deflector mirror from the bracket.

### Mounting a new deflector mirror

- ▶ Insert the new deflector mirror into the 180° mounting bracket.
- ▶ Fasten the deflector mirror onto the bracket with the two fixing screws.
- ▶ Remove the protective film from the new deflector mirror.
- ✓ Check that the deflector mirror is aligned correctly.

## 7 MAINTENANCE AND REPAIR

### 7.2.3 Replacing the incremental encoder components

If the incremental encoder is defective, it must be replaced immediately.

#### Replacement device

Part no.	Meaning
2058477	DFV60 incremental encoder

#### ⚠ WARNING

**Do not violate LFT mode on the VMS5200.**

The VMS5200 multi-dimensional measurement system is operated in LFT mode.

- ▶ Do not replace the incremental encoder yourself.
- ▶ Do not break any adhesive seals.
- ▶ If repairs are required, contact the manufacturer.

#### Removing a defective encoder

- ▶ Unscrew the M12 plug connection from the male connector on the incremental encoder.
- ▶ Loosen and remove the fixing screws.

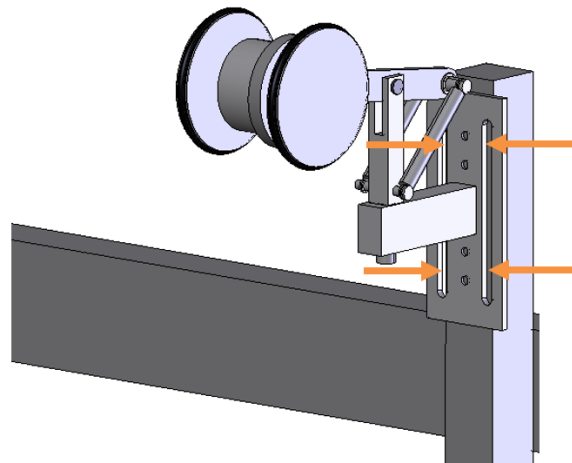

Fig. 72: Replacing the incremental encoder

#### Mounting the replacement device

- ▶ Mount the replacement device on the conveyor belt (for more information, see section [4.2 Mounting the incremental encoder](#)).
- NOTE!** Observe the correct mounting direction.
- ▶ Screw the M12 plug connection onto the male connector on the incremental encoder.

## 7.2.4 Replacing the photoelectric retro-reflective sensor

### Replacing the component

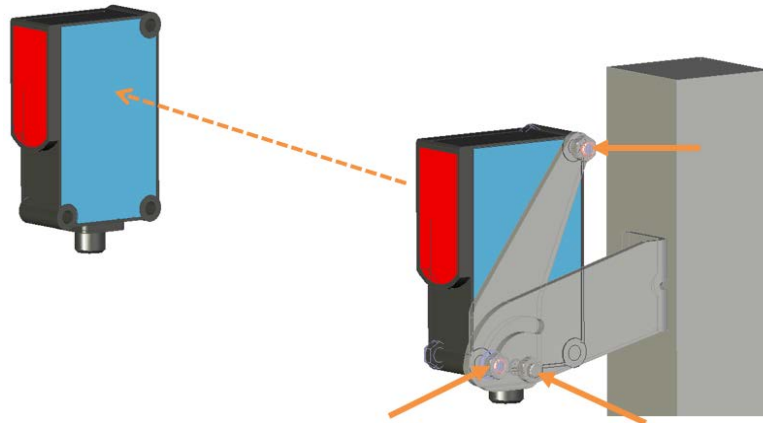

Fig. 73: Removing the object detection photoelectric sensor

- ▶ Unscrew the M12 plug connection from the male connector on the object detection photoelectric sensor.
- ▶ Remove the clinch stud.
- ▶ Unscrew the hexagon screws.
  - NOTE!** Hold the object detection photoelectric sensor firmly with one hand during the procedure.
- ▶ Remove the defective photoelectric sensor from the mounting bracket.
- ▶ Screw the replacement device onto the mounting bracket.
- ▶ Secure the replacement device using the clinch stud.
- ▶ Screw the M12 plug connection onto the male connector on the object detection photoelectric sensor.
- ▶ Align the photoelectric sensor correctly on the reflector. The reflector must be positioned within the beam path of the object detection photoelectric sensor.
- ✓ Check that the object detection photoelectric sensor is operating correctly.

## 7 MAINTENANCE AND REPAIR

### 7.2.5 Replacing the battery in the SIM2000-2 Prime controller

A battery powers the real-time clock of the SIM2000-2 Prime controller. The battery must be replaced when drained.

---

**⚠ WARNING!**

**RISK OF INJURY FROM HOT SURFACES**

Risk of burns due to hot surfaces on the controllers during operation.

- ▶ Do not touch hot surfaces.
  - ▶ Wear suitable safety gloves.
- 



Fig. 74: Position of the battery in the controller

- ▶ Remove the black plastic cover on the SIM2000-2 Prime controller.
- ▶ Remove the battery from the bracket and replace it with a new **CR 1632** type battery.
- ▶ Put the black plastic cover back in place.
- ▶ Dispose of the old battery as hazardous waste as per the ROHS directives (Europe).



## 8 Fault diagnosis

### 8.1 Fault indications of the components

#### 8.1.1 Fault indication on the LMS4x21

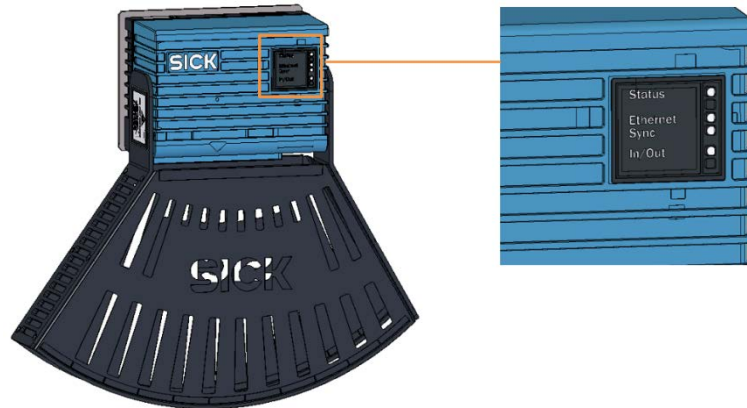

Fig. 75: Status indicators on the LMS4x21

<b>Fault indication</b> The <b>Status</b> LED does not light up.	
<b>Fault cause</b>	<b>Possible solution to the problem</b>
Fuse is defective.	▶ Check the fuse block in the cabinet of the SIM2000-2 Prime controller and replace the defective fuse if necessary.

<b>Fault indication</b> The <b>Status</b> LED lights up red. The 2D LiDAR sensor independently monitors beam generation and automatically shuts it down in the event of irregularities. The scanner will no longer send any measured values.	
<b>Fault cause</b>	<b>Remedy</b>
<ul style="list-style-type: none"> <li>• Error during initialization or self-test.</li> <li>• LMS4x21 is not in measuring mode or is in measuring mode, but errors have occurred.</li> </ul>	<ul style="list-style-type: none"> <li>▶ Check the voltage supply.</li> <li>▶ Interrupt the voltage supply to the LMS4x21.</li> <li>▶ Restore the voltage supply.</li> </ul> <p>If the fault persists or occurs again after the voltage supply has been restored:</p> <ul style="list-style-type: none"> <li>▶ Check the device status using SOPAS (see below).</li> <li>▶ If errors are listed there, contact SICK Service.</li> </ul>

Tab. 19: Fault indication on the 2D LiDAR sensor

## 8 FAULT DIAGNOSIS

### 8.1.2 SIM2000 fault indication

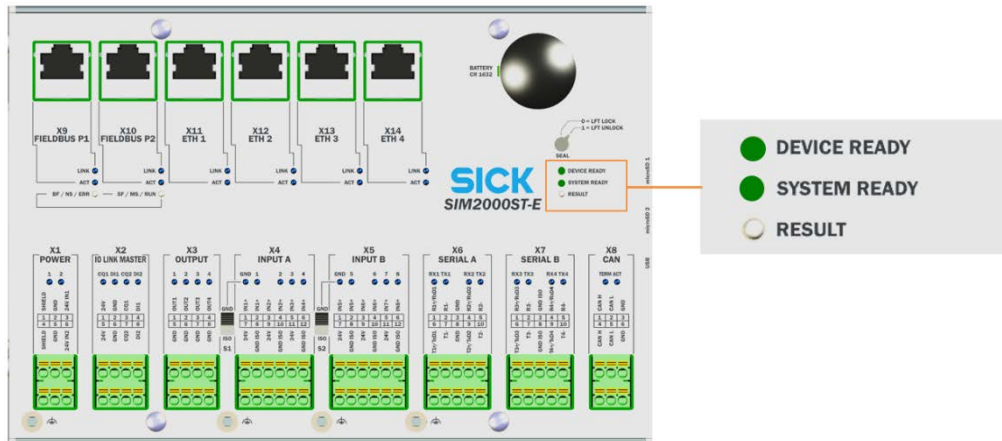

Fig. 76: Fault situation: Checking normal operation of the SIM2000-2 Prime controller

<b>Fault indication</b>	
The <b>Dev RDY</b> LED does not light up.	
<b>Fault cause</b>	<b>Possible solution to the problem</b>
Fuse is defective.	▶ Check the fuse block and replace the defective fuse if necessary.
Voltage is not switched on.	▶ Establish the correct voltage supply.
SIM2000-2 Prime controller defective.	▶ Exchange SIM2000-2 Prime controller.

If all of the connected sensors are configured and working properly, the **Sys RDY** LED lights up on the SIM2000-2 Prime controller. This means that the SIM200-2 Prime controller has received a positive feedback signal from all the components and that the devices are communicating with one another.

<b>Fault indication</b>	
The <b>Dev RDY</b> LED does not light up.	
<b>Fault cause</b>	<b>Possible solution to the problem</b>
CAN cable is attached incorrectly.	▶ Check the CAN cabling and establish connections in accordance with the electrical diagram.
Defective Ethernet connection to sensor components.	▶ Check the Ethernet connections.
Ethernet cable is defective.	▶ Replace the Ethernet cable.
LMS4x21 is defective.	▶ Replace the sensor component.

Tab. 20: Fault indication on SIM2000-2 Prime controller

8.1.3 Fault indication on the trigger photoelectric sensor

<b>Fault indication</b> LED receive indicator is permanently off.	
<b>Fault cause</b>	<b>Possible solution to the problem</b>
Reflector is not positioned in the beam path of the photoelectric sensor.	▶ Readjust the photoelectric sensor, clean it, or check the application conditions.

<b>Fault indication</b> LED receive indicator is flashing.	
<b>Fault cause</b>	<b>Possible solution to the problem</b>
Reflector is being detected in the fringe range.	▶ Readjust the photoelectric sensor, clean it, or check the application conditions.

<b>Fault indication</b> LED receive indicator lights up or flashes even when an object is present in the path of the beam.	
<b>Fault cause</b>	<b>Possible solution to the problem</b>
Reflector is being detected in the fringe range.	▶ Readjust the photoelectric sensor, clean it, or check the application conditions.

Tab. 21: Fault indication on the trigger photoelectric sensor

## 8 FAULT DIAGNOSIS

### 8.2 Checks on the SIM2000

#### 8.2.1 Checking the triggering

If the photoelectric sensor has been correctly connected via the **X4 INPUT A** terminal block, LED **1** should light up if both the measuring range and the access to the reflector are clear.

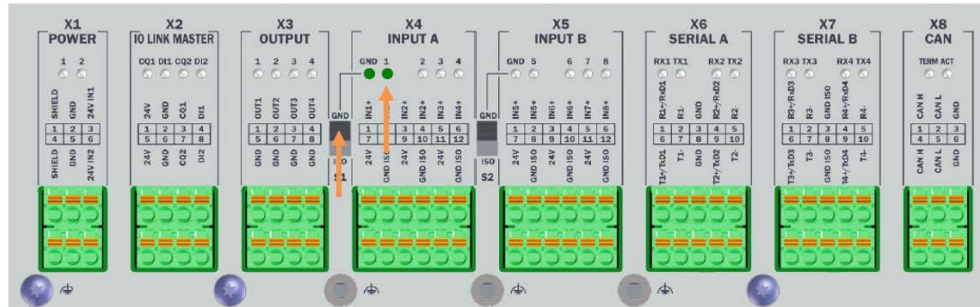

Fig. 77: Checking triggering on the SIM2000-2 Prime controller

<b>Fault indication</b>	
The LED on the trigger connection does not light up.	
<b>Fault cause</b>	<b>Possible solution to the problem</b>
Beam path is permanently interrupted by an object	► Eliminate the permanent interruption by the object.
Photoelectric sensor is not aligned with the reflector	► Readjust the photoelectric sensor and align it with the reflector.
Signal ground not activated	► Set the <b>S1</b> signal ground switch to <b>GND</b> .
Wire is not correctly attached in the terminal block.	► Check that the wires are attached correctly.
Photoelectric sensor is defective	► Replace the device.

Tab. 22: Checking triggering on the SIM2000-2 Prime controller

8.2.2 Checking the incremental encoder

If the incremental encoder has been correctly connected via the **X5 INPUT B** terminal block, LEDs **5** and **6** should flash when the conveyor belt is turning.

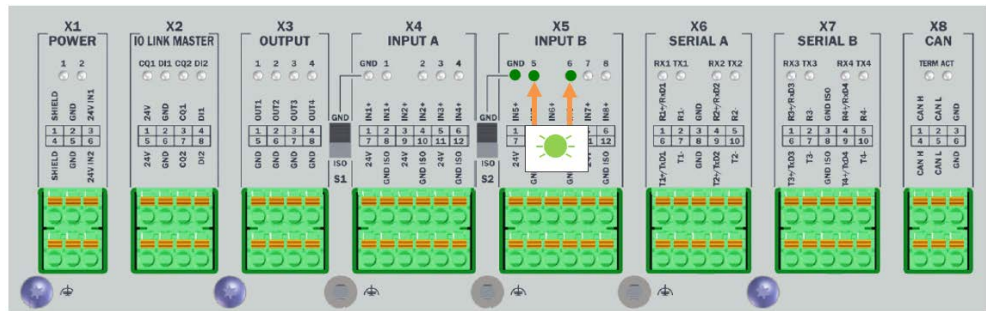

Fig. 78: Checking incremental signals on the SIM2000-2 Prime controller

<b>Fault indication</b>	
LEDs are not flashing.	
<b>Fault cause</b>	<b>Possible solution to the problem</b>
There is no/insufficient contact between the measuring wheel and the conveyor belt.	<ul style="list-style-type: none"> <li>▶ Make sure that there is good contact between the measuring wheel and the conveyor belt on-site.</li> <li>▶ If the measuring wheel shows signs of wear, replace it.</li> </ul>
Signal ground not activated.	▶ Set the <b>S2</b> signal ground switch to <b>GND</b> .
Wire is not correctly attached in the terminal block.	▶ Check that the wires are attached correctly.
Encoder is defective.	▶ Replace the device.

Tab. 23: Checking incremental signals on the SIM2000-2 Prime controller

## 8 FAULT DIAGNOSIS

### 8.2.3 Checking the CAN cabling

If the CAN is cabled correctly, the **ACT** LED in the **CAN** terminal block lights up dimly during operation.

If the conveyor belt is switched off, the LED should flicker if the CAN cabling is correct.

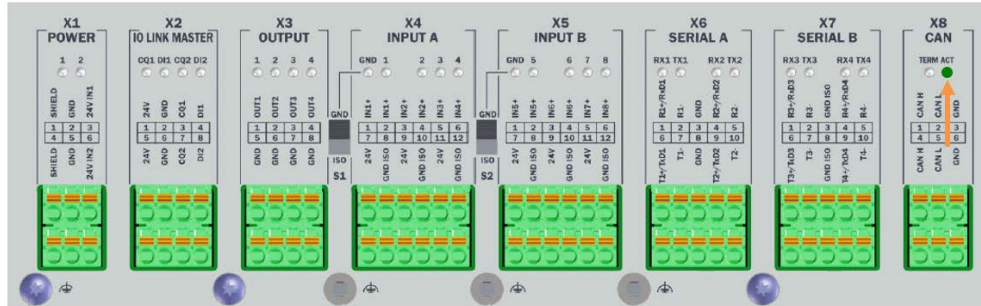

Fig. 79: Checking CAN cabling on the SIM2000-2 Prime

<b>Fault indication</b>	
The LED lights up brightly like the others. There is a problem with the CAN connection.	
<b>Fault cause</b>	<b>Possible solution to the problem</b>
The wires have been swapped	▶ Connect the CAN cables in accordance with the electrical diagram.
Wire is not correctly attached in the terminal block.	▶ Check that the wires are attached correctly.
Terminator is defective	▶ Replace the terminator.

Tab. 24: Checking CAN cabling on the SIM2000-2 Prime

### 8.3 Detailed fault analysis

The SIM2000-2 Prime controller outputs faults in a staggered manner in messages. This means that a more detailed analysis is always possible.

- Communication errors can, for example, occur when transmitting telegrams to the SIM2000-2 Prime controller. The SIM2000-2 Prime controller then returns a fault code.
- For faults that occur during measuring or reading, fault codes are written to a **status log**.

#### Message types

The status log distinguishes between four message types:

- Information
- Warning
- Error
- Critical fault

The system saves only the last five entries for each message type.

*Information* and *Warning* messages are deleted after a restart.

#### Calling up the status log



- ▶ Call up the status log using the SOPAS configuration software.
- ▶ To do this, install SOPAS on a computer and connect the computer to the SIM2000-2 Prime controller via Ethernet.

**NOTE!** Please contact SICK Support for a more detailed analysis of the fault situation.

9 Technical data

9.1 Data sheet

Type	VMS4200	VMS5200
Type	Two-scanner solution	
Laser output aperture	On the front	
Laser diode (wavelength)	Visible light ( $\lambda = 650 \text{ nm}$ )	
Laser power	Max. 13 mW	
Laser class of the device	2	
Usable aperture angle	Max. 70°	
Detectable object shape	Almost any.▯ Object dimensions must be at least 50 mm × 50 mm × 20 mm	
Min. object size (L × W × H) (operating condition 1) Certified scale value At v = 0.1 m/s to 4.0 m/s	50 mm x 50 mm x 20 mm / 2.0" x 2.0" x 1.0"  5 mm (0.2") x 5 mm x 2 mm / 0.2" x 0.2" x 0.1"	
Min. object size (L × W × H) (operating condition 2) Certified scale value At v = 0.1 m/s to 4.0 m/s	50 mm x 50 mm x 50 mm / 2.0" x 2.0" x 2.0"  5 mm x 5 mm x 5 mm / 0.2" x 0.2" x 0.2"	
Min. object size (L × W × H) (operating condition 3) Certified scale value At v = 0.1 m/s to 4.0 m/s	100 mm x 50 mm x 50 mm / 4.0" x 2.0" x 2.0"  10 mm x 5 mm x 5 mm / 0.4" x 0.2" x 0.2"	
Min. object size (L × W × H) (operating condition 4) Certified scale value At v = 0.1 m/s to 4.0 m/s	100 mm x 100 mm x 50 mm / 4.0" x 4.0" x 2.0"  10 mm x 10 mm x 5 mm / 0.4" x 0.4" x 0.2"	
Min. object size (L × W × H) (operating condition 5) Certified scale value At v = 0.1 m/s to 4.0 m/s	100 mm x 100 mm x 100 mm / 4.0" x 4.0" x 4.0"  10 mm x 10 mm x 10 mm / 0.4" x 0.4" x 0.4"	
Min. object size (L × W × H) (operating condition 6) Certified scale value At v = 0.1 m/s to 4.0 m/s	100 mm x 50 mm x 20 mm / 4.0" x 2.0" x 1.0"  10 mm x 5 mm x 2 mm / 0.4" x 0.2" x 0.1"	
Min. object size (L × W × H) (operating condition 7) Certified scale value At v = 0.1 m/s to 4.0 m/s	100 mm x 100 mm x 20 mm / 4.0" x 4.0" x 1.0"  10 mm x 10 mm x 2 mm / 0.4" x 0.4" x 0.1"	



Min. object size (L × W × H) (operating condition 8)	200 mm x 50 mm x 20 mm / 8.0" x 2.0" x 1.0"
Certified scale value At v = 0.1 m/s to 4.0 m/s	20 mm x 5 mm x 2 mm / 0.8" x 0.2" x 0.1"
Remission factor	2% to 200%
Min. object gap	50 mm
Max. conveyor speed	4.0 m/s, start/stop operation permitted
Optical displays	4 LEDs per LMS4x21
Host interface	Ethernet-based fieldbuses or serial RS-232, 422, 485
Output data	Maximum dimensions (length, width, height)
Supply voltage/power consumption	DC 24 V ± 10% / ~ 60 W typ.
Supply voltages	230 V AC, 100 V AC ... 264 V AC
Housing	Aluminum die cast
Enclosure rating/protection class	IP 20 (in accordance with DIN 40050); with IP 65 male connector cover
EMC test	In accordance with EN 61000-6-2:2001, EN 61000-6-4:2001
Vibration/shock check	In accordance with EN 60068-2-6, -27, -29, -64
Weight	Approx. 2.4 kg per LMS4x21 without laser protective cover Approx. 3.7 kg per LMS4x21 with laser protective cover
Temperature (operation/storage)	-10 °C ... +50 °C / -20 °C ... +70 °C

Tab. 25: Technical data of the VMS4200/5200

9.2 Dimensional drawings

9.2.1 Dimensional drawings for the 2D LiDAR sensor

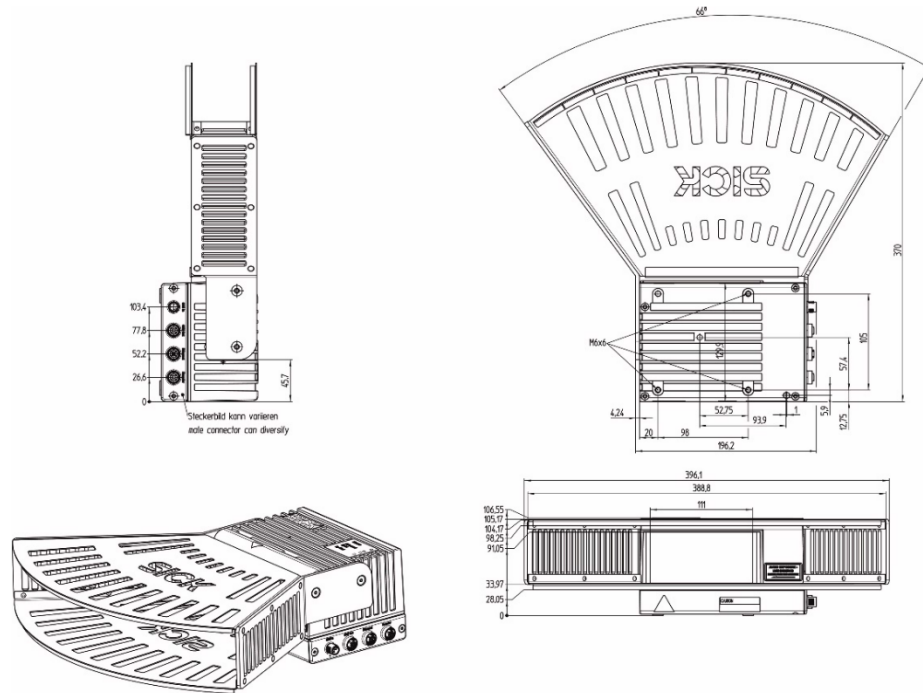

Fig. 80: LMS4x21 dimensional drawing with laser protective cover

9.2.2 Dimensional drawings for the cabinet

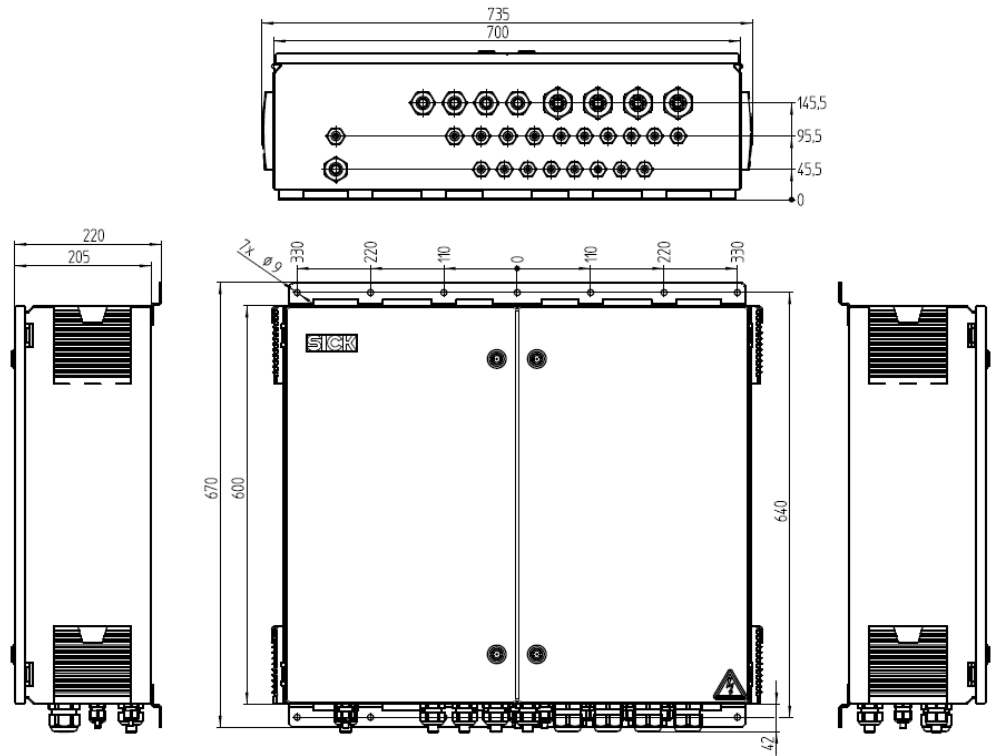

Fig. 81: TTC100-2 dimensional drawings

### 9.3 Compliance with EU directives

#### EU declaration of conformity (extract)

The undersigned, who represents the manufacturer below, hereby declares that the product complies with the regulations of the EU directive(s) below (including all relevant changes), and that it is based on the relevant standards and/or technical specifications.

#### Complete EU declaration of conformity available for downloading

You can access the EU declaration of conformity and the current operating instructions for the protective device by entering the part number in the search field at [www.sick.com](http://www.sick.com) (part number: see the type label entry in the **Ident. no.** field).

After a successful conformity assessment, the declaration of conformity for the system is declared according to the following directive:

- Measuring Instruments Directive: 2014/32 / EU (2016-04-20)

**NOTE!** After the successful conformity assessment, a certificate is issued to the customer/operating entity and must be archived in a readily retrievable manner for market monitoring purposes.

## 10 Disposal

### NOTE

The applicable local and statutory environmental regulations and guidelines for the disposal of industrial and electrical waste must be observed.

### NOTE

Disposal of batteries, electrical and electronic devices.

- ▶ In accordance with international directives and regulations, batteries, accumulators, and electrical or electronic devices must not be disposed of with household waste.
- ▶ The owner is obligated to dispose of the devices at the end of their service life via the appropriate public disposal points.
- ▶ This icon on the product, packaging, or in this document indicates that a product is covered by these provisions.



The following assemblies may contain substances that need to be disposed of separately:

- **Electronics:**  
Capacitors, accumulators, batteries.
- **Displays:**  
Liquid in the LC displays.