

ADDENDUM OPERATING INSTRUCTIONS

M4000 Standard Curtain and
M4000 Advanced Curtain

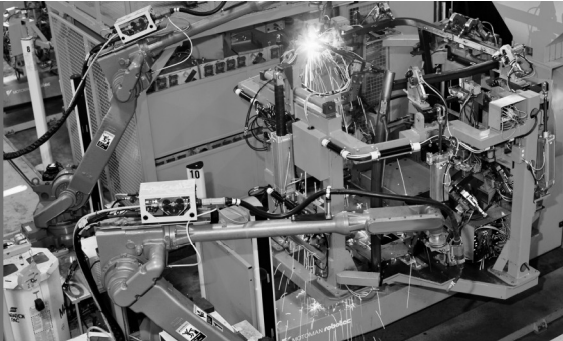

Multiple Light Beam Safety Device

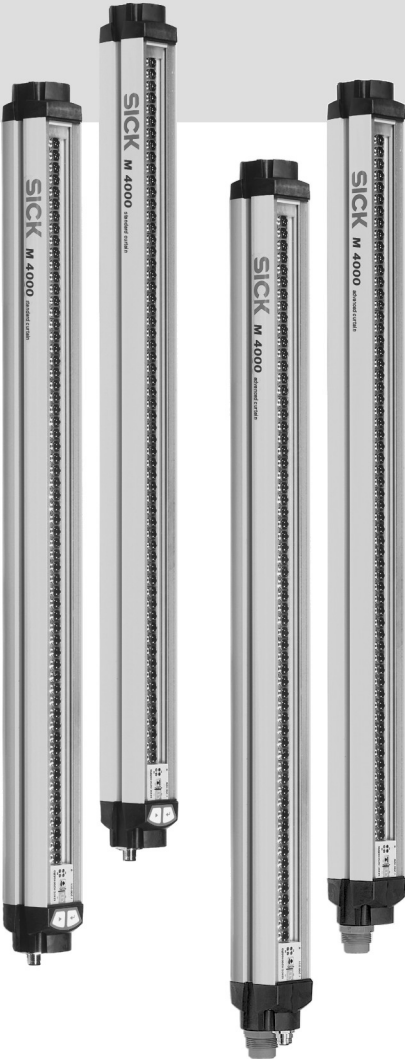

en

This document is protected by the law of copyright, whereby all rights established therein remain with the company SICK AG. Reproduction of this document or parts of this document is only permissible within the limits of the legal determination of Copyright Law. Alteration or abridgement of the document is not permitted without the explicit written approval of the company SICK AG.



Content

1	About this document.....	5
1.1	Scope.....	5
1.2	Abbreviations and terms.....	5
2	On safety.....	6
2.1	Applications of the device.....	6
2.2	General safety notes and protective measures.....	6
3	Product description.....	7
3.1	Differences to the M4000 Standard or M4000 Advanced multiple light beam safety device.....	7
3.2	Operating principle of the device.....	7
3.2.1	Device components.....	7
3.2.2	Principles of operation	8
3.3	Application examples.....	9
4	Configurable functions.....	10
4.1	Scanning range.....	10
5	Mounting	12
5.1	Determining the safety distance.....	12
5.1.1	Safety distance from the hazardous point.....	12
5.1.2	Minimum distance to reflective surfaces	16
5.2	Steps for mounting the device.....	17
6	Commissioning.....	18
6.1	Alignment of the M4000 Curtain system.....	18
6.2	Test notes.....	18
6.2.1	Daily functional checks of the protective device	18
7	Technical specifications	20
7.1	Data sheet.....	20
7.2	Response time.....	21
7.3	Table of weights.....	21
7.3.1	M4000 Curtain system.....	21
7.4	Dimensional drawings	22
7.4.1	M4000 Standard Curtain system.....	22
7.4.2	M4000 Advanced Curtain system.....	24
7.4.3	Deflector mirror PNS75.....	25
7.4.4	Deflector mirror PNS125.....	26

8	Order data	27
8.1	M4000 Standard Curtain system.....	27
8.1.1	Type code.....	27
8.1.2	Default delivery status.....	28
8.2	M4000 Standard AS-i Curtain system.....	29
8.2.1	Type code.....	29
8.2.2	Default delivery status.....	29
8.3	M4000 Advanced Curtain system.....	30
8.3.1	Type code.....	30
8.3.2	Default delivery status.....	32
8.4	Additional front screens (weld spark guard)	32
8.5	Deflector mirror.....	33
8.5.1	Deflector mirror PNS75 for protective field width 0 ... 8 m (total).....	33
8.5.2	Deflector mirror PNS125 for protective field width 4 ... 17 m (total).....	33
9	Annex	34
9.1	List of tables	34
9.2	List of illustrations.....	35

1 About this document

1.1 Scope

These operating instructions are original operating instructions.

This addendum applies to the following systems:

- **M4000 Standard Curtain system**

- only with one of the following type label entries in the field *Operating Instructions*:

- 8011190_PE79, 8011561
- 8011190_PE79, 8011561_QG67
- 8011190_TI79, 8011561_TI80
- 8011190_UN30, 8011561_TI80
- 8011190_WP69, 8011561_TI80
- 8011190_YT81, 8011561_YT74

- only in conjunction with the original operating instructions “M4000 Standard and M4000 Standard A/P – Multiple Light Beam Safety Device” (SICK part number 8011190)

If not otherwise revised in this addendum, the information in the original operating instructions applies, which relate to the M4000 Standard multiple light beam safety device (not: M4000 Standard A/P).

- **M4000 Advanced Curtain system**

- only with one of the following type label entries in the field *Operating Instructions*:

- 8010794_PE80, 8011561
- 8010794_Q900, 8011561
- 8010794_Q900, 8011561_QG67
- 8010794_TI75, 8011561_TI80
- 8010794_UN30, 8011561_TI80
- 8010794_WP70, 8011561_TI80
- 8010794_YT72, 8011561_YT74

- only in conjunction with the original operating instructions “M4000 Advanced, M4000 Advanced A/P and M4000 Area 60/80 – Multiple Light Beam Safety Device” (SICK part number 8010794)

If not otherwise revised in this addendum, the information in the original operating instructions applies, which relate to the M4000 Advanced multiple light beam safety device (not: M4000 Advanced A/P, M4000 Area 60/80).

Note This document is part of SICK part number 8011561 (addendum to operating instructions “M4000 Standard Curtain and M4000 Advanced Curtain – Multiple Light Beam Safety Device” in all available languages).

1.2 Abbreviations and terms

The information in this section **is additional** to the information in the related section of the original operating instructions.

M4000 Curtain system

Short for M4000 Standard Curtain system and M4000 Advanced Curtain system.

Resolution

Minimum size of a test rod that is reliably detected by the protective device. The resolution is measured from the outside edge of a beam to the opposite outside edge of the neighbouring beam.

2 On safety

Note The information in this chapter **is additional** to the information in the related section of the original operating instructions.

2.1 Applications of the device

The M4000 Curtain system is an electro-sensitive protective equipment (ESPE). The physical resolution is 14 or 30 mm with a protective field width of up to 21 m. The realisable protective field height is between 300 and 1800 mm, with AS-i between 300 and 1200 mm.

The device is a Type 4 ESPE as defined by IEC 61496-1 and IEC 61496-2 and is therefore allowed for use with controls in safety category 4 according to EN ISO 13849-1. The M4000 Curtain system is suitable for:

- hazardous point protection (finger and hand protection)
- hazardous area protection
- access protection

Access to the hazardous point must be allowed only through the protective field. The plant/system is not allowed to start as long as personnel are within the hazardous area. Refer to section 3.3 “Application examples” on page 9 for an illustration of the protection modes.

The M4000 Curtain system is only intended for use in industrial environments. When used in residential areas it can cause radio interferences.



WARNING

Only use the M4000 Curtain system as an indirect protective measure!

An opto-electronic protective device as the M4000 Curtain system cannot provide any protection against parts thrown out or against radiation. Transparent objects are not detected.

Depending on the application, mechanical protective devices may be required in addition to the M4000 Curtain system.

2.2 General safety notes and protective measures



WARNING

Safety notes

This addendum to the operating instructions must be made available to the operator of the machine where the M4000 Curtain system is used, together with the original operating instructions. The machine operator is to be instructed in the use of the device by specialist personnel and must be instructed to read and observe the operating instructions.

Please observe the general safety notes and protective measures in chapter 2 of the original operating instructions.

3 Product description

3.1 Differences to the M4000 Standard or M4000 Advanced multiple light beam safety device

This section identifies the key differences between the M4000 Curtain system and the M4000 Standard or M4000 Advanced multiple light beam safety device.



WARNING

Note the different calculation of the safety distance to the hazardous point!

The safety distance to the hazardous point must be calculated differently to the method given in the original operating instructions for the M4000 Curtain system due to the higher resolution! The method is described in this document in section 5.1 “Determining the safety distance” from page 12.

- resolution (see section 3.3 “Application examples” on page 9):
 - 14 mm, suitable for finger protection
 - 30 mm, suitable for hand protection
- scanning range 8 to 19 m (depending on type, see Tab. 5 “Data sheet M4000 Curtain system” on page 20)
- protective field height 300 to 1800 mm
- not available with laser alignment aid

3.2 Operating principle of the device

Note The information in this section **replaces** the information in the related section of the original operating instructions.

3.2.1 Device components

Fig. 1: Device components of the M4000 Curtain system

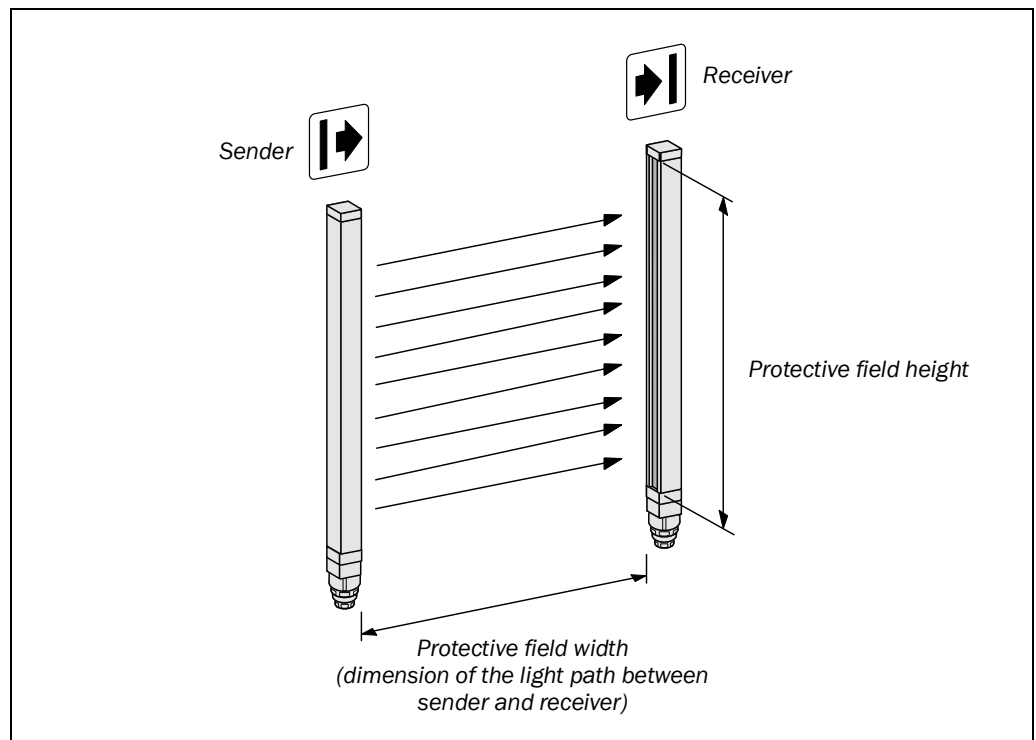

The M4000 Curtain system consists of a sender and a receiver (see Fig. 1). Between these is the *protective field*, defined as the *protective field height* and the *protective field width*.

The size of the related system defines the *protective field height*. For the respective protective field height, please see Fig. 10 in section 7.4 “Dimensional drawings” on page 22.

The *protective field width* is derived from the dimension of the light path between sender and receiver and must not exceed the maximum permissible scanning range (see section 4.1 “Scanning range” on page 10).

Sender and receiver automatically synchronise themselves optically. An electrical connection between both components is not required.

The M4000 Curtain system is modular in structure. All optical and electronic components and assemblies are housed in a slim and torsionally rigid housing.

3.2.2 Principles of operation

The M4000 Curtain system secures the access to a hazardous area or a hazardous point and signals the entry of objects as soon as a light beam is interrupted. The machine or plant controller that evaluates this message must then bring the dangerous movement to a halt. You can secure two sides of a hazardous area or a hazardous point by using a deflector mirror, with two deflector mirrors you can secure three sides (see section “Access protection on several sides with the aid of deflector mirrors” in chapter 3 of the original operating instructions.).

The protective field width must not exceed the maximum permissible scanning range (see section 4.1 “Scanning range” on page 10).

M4000 Std./Adv. Curtain

3.3 Application examples

Note The information in this section **replaces** the information in the related section of the original operating instructions.

Fig. 2: Hazardous point protection with a M4000 Curtain system (left)

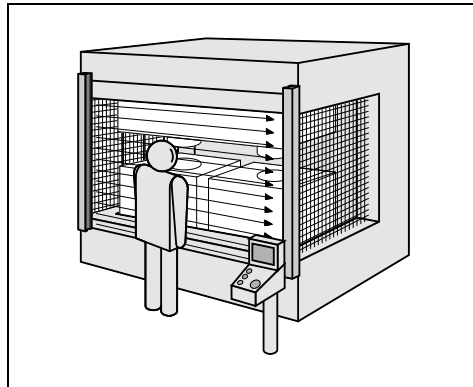

Fig. 3: Hazardous area protection with a M4000 Curtain system (right)

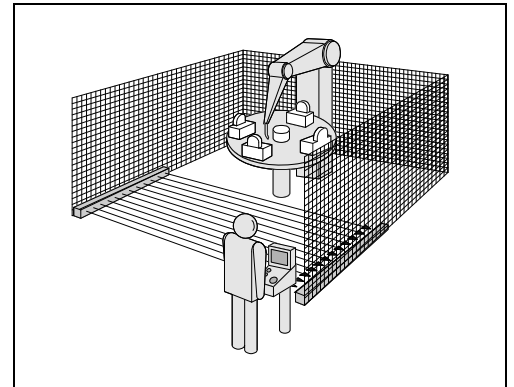
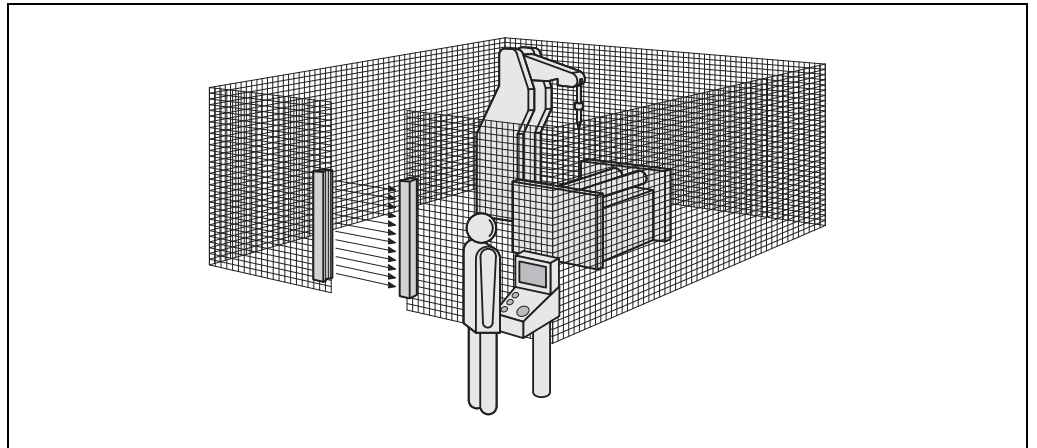

Fig. 4: Access protection with a M4000 Curtain system



The M4000 Curtain system operates correctly as a protective device only if the following conditions are met:

- The control of the machine must be electrical.
- It must be possible to achieve a safe state on the machine at any time.
- Sender and receiver must be mounted in a way that objects penetrating the hazardous area are safely identified by the M4000 Curtain system.
- The reset button must be fitted outside the hazardous area such that it cannot be operated by a person working inside the hazardous area. When operating the reset button, the operator must have full visual command of the hazardous area.
- The statutory and local rules and regulations must be observed when installing and using the device.

4 Configurable functions

4.1 Scanning range

Note The information in this section **replaces** the information in the related section of the original operating instructions.

You can set the M4000 Curtain system to two different scanning ranges (cf. Tab. 1):

Tab. 1: Guaranteed scanning ranges for the M4000 Curtain system as a function of the physical resolution

Physical resolution	Low scanning range	High scanning range
14 mm	0-2.5 m	2-8 m
30 mm	0-6 m	5-19 m

Note Tab. 1 shows the guaranteed scanning ranges for the system. You can also use the M4000 Curtain system in applications that require a larger scanning range if the orange LED is not illuminated at the required scanning range.



WARNING

Configure the scanning range to suit the protective field width!

The scanning range of each system must be adapted to the protective field width.

- If the scanning range is set too low, the M4000 Curtain system may not switch to green.
- If the setting for the scanning range is too great, the M4000 Curtain system may malfunction due to reflections. This would mean that the operator is at risk.



Only M4000 Advanced Curtain system:

Device symbol **M4000 Advanced Curtain (receiver)**, context menu **Open device window**, parameter node **General**.



Only M4000 Standard Curtain system:

The setting is made with the aid of the configuration buttons. The procedure is described in the “Configuration” chapter in the original operating instructions.

- Notes**
- The additional front screens, which are available as accessories (see section 8.4 “Additional front screens (weld spark guard)” on page 32), reduce the effective scanning range per additional front screen by 8%.
 - The deflector mirrors available as accessories (see section 8.5 “Deflector mirror” on page 33) reduce the system’s effective scanning range as a function of the number of deflector mirrors in the light path (see Tab. 2).

Tab. 2: Effective scanning range of the M4000 Curtain system when using 1 or 2 deflector mirrors

Deflector mirror	Effective scanning range			
	14 mm		30 mm	
	Minimum	Typical	Minimum	Typical
1 × PNS75	6.6 m	7 m	8 m	13 m
2 × PNS75	6.3 m	7 m	8 m	12 m
1 × PNS125	7.1 m	9 m	17 m	18.5 m
2 × PNS125	6.3 m	8 m	15.2 m	16.8 m

The data in the table relate to 90° beam deflection per deflector mirror and a protective field height of 900 mm without the use of additional front screens.

M4000 Std./Adv. Curtain

When using deflector mirrors, you **must** configure the M4000 Curtain system for a large scanning range.

**WARNING**

Do not use deflector mirrors if the formation of droplets or heavy contamination of the deflector mirrors is to be expected!

The formation of droplets or heavy contamination can be detrimental to the reflection behaviour. The protective function of the system will be affected and the system will thus become unsafe. This would mean that the operator is at risk.

If you need more advice on mirror applications, please get in touch with your contact at SICK.

5 Mounting

5.1 Determining the safety distance

Note The information in this section **replaces** the information in the related section of the original operating instructions.

The M4000 Curtain system must be mounted with the correct safety distance:

- safety distance from the hazardous point
- safety distance from reflective surfaces



WARNING

No protective function without sufficient safety distance!

You must mount the M4000 Curtain system with the correct safety distance to the hazardous area/the hazardous point. Otherwise the safe protection of the M4000 Curtain system is not provided.

Risk of failure to detect!

Persons who are in the hazardous area but not in the protective field are not detected by the M4000 Curtain system. It is therefore to be ensured that the hazardous area is fully visible and a dangerous state can only be initiated if there are no personnel in the hazardous area.

Note The applicable legal and official regulations apply to the use and mounting of the protective device. These regulations vary depending on the application.

5.1.1 Safety distance from the hazardous point

A safety distance must be maintained between the M4000 Curtain system and the hazardous point. This safety distance ensures that the hazardous point can only be reached after the dangerous state of the machine has been completely stopped.

The safety distance as defined in EN ISO 13 855 and EN ISO 13 857 depends on:

- stopping/run-down time of the machine or system
(The stopping/run-down time is shown in the machine documentation or must be determined by taking a measurement.)
- response time of the entire protective device, e.g. M4000 Curtain system (response times see section 7.1 “Data sheet” on page 20)
- reach or approach speed
- resolution of the M4000 Curtain system
- other parameters that are stipulated by the standard depending on the application

Under the authority of OSHA and ANSI the safety distance as specified by ANSI B11.19:2003-04, Annex D, and Code of Federal Regulations, Volume 29, Part 1910.217 ... (h) (9) (v) depends on:

- stopping/run-down time of the machine or system
(The stopping/run-down time is shown in the machine documentation or must be determined by taking a measurement.)
- response time of the entire protective device, e.g. M4000 Curtain system (response times see section 7.1 “Data sheet” on page 20)
- reach or approach speed
- other parameters that are stipulated by the standard depending on the application

Fig. 5: Safety distance from the hazardous point

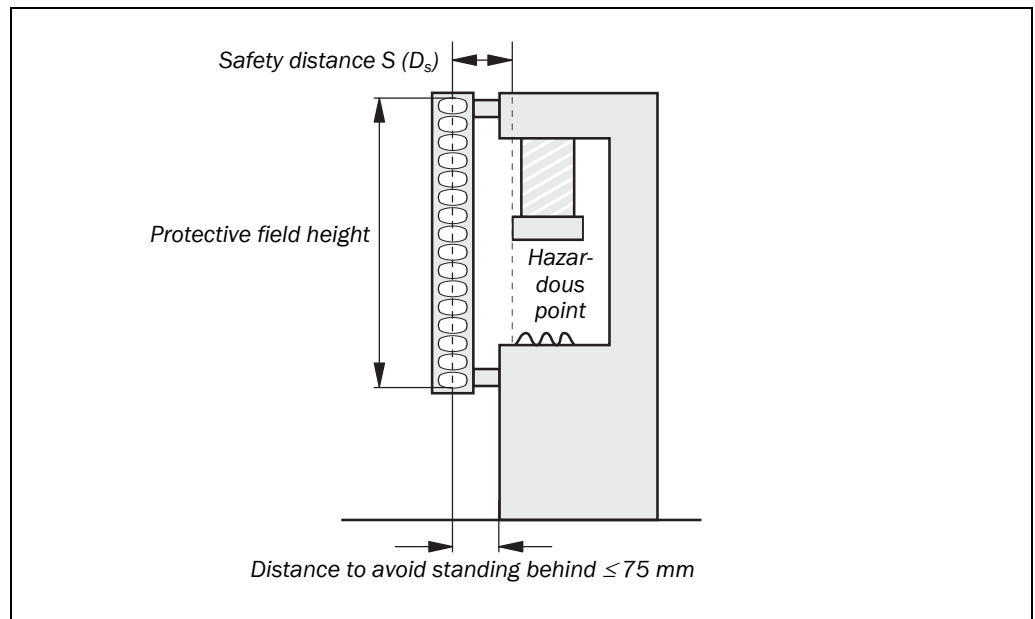

How to calculate the safety distance S according to EN ISO 13 855 and EN ISO 13 857:

Note The following calculation shows an example calculation of the safety distance. Depending on the application and the ambient conditions, a different calculation may be necessary.

➤ First, calculate S using the following formula:

$$S = 2000 \times T + 8 \times (d - 14) \text{ [mm]}$$

Where ...

T = Stopping/run-down time of the machine

+ Response time of the protective device after light path interruption [s]

+ Response time of the AS-Interface safety monitor¹⁾ [s]

d = Resolution of the M4000 Curtain system [mm]

S = Safety distance [mm]

The reach/approach speed is already included in the formula.

➤ If the result S is ≤ 500 mm, then use the determined value as the safety distance.

➤ If the result S is > 500 mm, then recalculate S as follows:

$$S = 1600 \times T + 8 \times (d - 14) \text{ [mm]}$$

➤ If the new value S is > 500 mm, then use the newly determined value as the minimum safety distance.

➤ If the new value S is ≤ 500 mm, then use 500 mm as the minimum safety distance.

¹⁾ Only on devices with integrated AS-Interface Safety at Work. The maximum response time of the AS-Interface safety monitor in an AS-Interface bus system with 31 slaves is 40 ms.

Example:

- stopping/run-down time of the machine = 290 ms
- response time after light path interruption = 30 ms
- response time of the AS-Interface safety monitor = 40 ms
- resolution of the M4000 Curtain system = 30 mm

$$T = 290 \text{ ms} + 30 \text{ ms} + 40 \text{ ms} = 360 \text{ ms} = 0.36 \text{ s}$$

$$S = 2000 \times 0.36 + 8 \times (30 - 14) = 848 \text{ mm}$$

$S > 500 \text{ mm}$, for this reason:

$$S = 1600 \times 0.36 + 8 \times (30 - 14) = \underline{704 \text{ mm}}$$

How to calculate the safety distance D_s according to ANSI B11.19:2003-04, Annex D, and Code of Federal Regulations, Volume 29, Part 1910.217 ... (h) (9) (v):

Note The following calculation shows an example calculation of the safety distance. Depending on the application and the ambient conditions, a different calculation may be necessary.

➤ Calculate D_s using the following formula:

$$D_s = H_s \times (T_s + T_c + T_r + T_{bm}) + D_{pf}$$

Where ...

D_s = The minimum distance in inches (or millimetres) from the hazardous point to the protective device

H_s = A parameter in inches/second or millimetres/second, derived from data on approach speeds of the body or parts of the body. Often 63 inches/second (1600 mm/second) is used for H_s .

T_s = Stopping/run down time of the machine tool measured at the final control element

T_c = Stopping/run-down time of the control system

T_r = Response time of the entire protective device after light path interruption

T_{bm} = Additional response time allowed for brake monitor to compensate for wear

Note Any additional response times must be accounted for in this calculation.

D_{pf} = An additional distance added to the overall safety distance required. This value is based on intrusion toward the hazardous point prior to actuation of the electro-sensitive protective equipment (ESPE). Values range from 0.25 inches to 48 inches (6 to 1220 millimetres) or more depending on application.

Example:

For perpendicular protection using an opto-electronic safety device with an object sensitivity (effective resolution) less than 2.5 inches (64 millimetres), D_{pf} can be approximated based on the following formula:

$$D_{pf} \text{ (inches)} = 3.4 \times (\text{effective resolution} - 0.276), \text{ but not less than } 0.$$

M4000 Std./Adv. Curtain

Calculation of the safety distance **S** for non-perpendicular approach

Fig. 6: Safety distance to the hazardous point for non-perpendicular approach

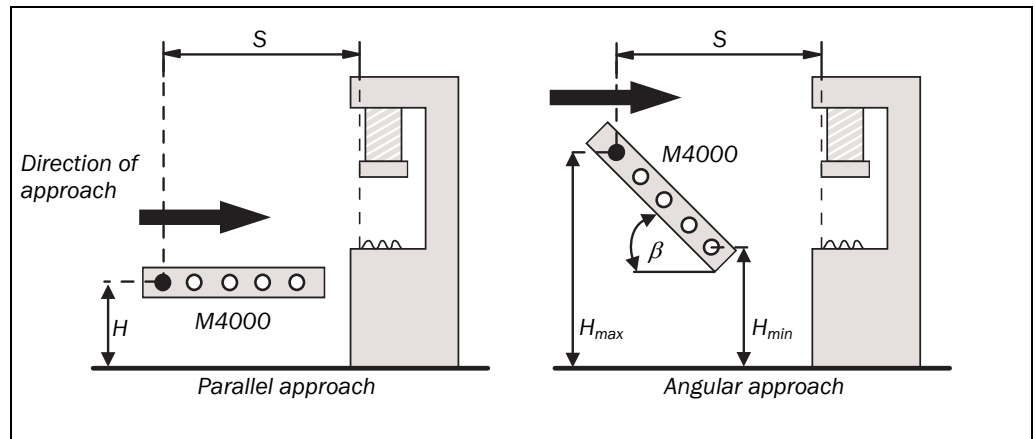
Tab. 3: Equations for calculating the safety distance **S**

Approach	Calculation	Conditions
Parallel	$S = 1600 \times T + (1200 - 0.4 \times H)$ [mm]	<ul style="list-style-type: none"> $1200 - 0.4 \times H > 850$ mm $15 \times (d - 50) \leq H \leq 1000$ mm
Angular	<ul style="list-style-type: none"> $\beta > 30^\circ$ Calculation as for perpendicular approach $\beta < 30^\circ$ Calculation as for parallel approach <p>S is applied to the beam that is the farthest away from the hazardous point.</p>	<ul style="list-style-type: none"> $d \leq H_{\min}/15 + 50$ $H_{\max} \leq 1000$ mm

Where ...

S = Safety distance [mm]

H = Height of the beams above the floor [mm]

For approach at an angle:

 H_{\max} = Height of the uppermost beam [mm] H_{\min} = Height of the bottom beam [mm]

d = Resolution of the M4000 Curtain system [mm]

 β = Angle between detection plane and the direction of entry [Deg]

T = Stopping/run-down time of the machine

+ Response time of the protective device after light path interruption [s]

+ Response time of the AS-Interface safety monitor²⁾ [s]

²⁾ Only on devices with integrated AS-Interface Safety at Work. The maximum response time of the AS-Interface safety monitor in an AS-Interface bus system with 31 slaves is 40 ms.

5.1.2 Minimum distance to reflective surfaces



WARNING

Maintain the minimum distance from reflective surfaces!

The light beams from the sender may be deflected by reflective surfaces. This can result in failure to identify an object. This would mean that the operator is at risk.

All reflective surfaces and objects (e.g. material bins) must be a minimum distance a from the protective field. The minimum distance a depends on the distance D between sender and receiver.

Fig. 7: Minimum distance to reflective surfaces

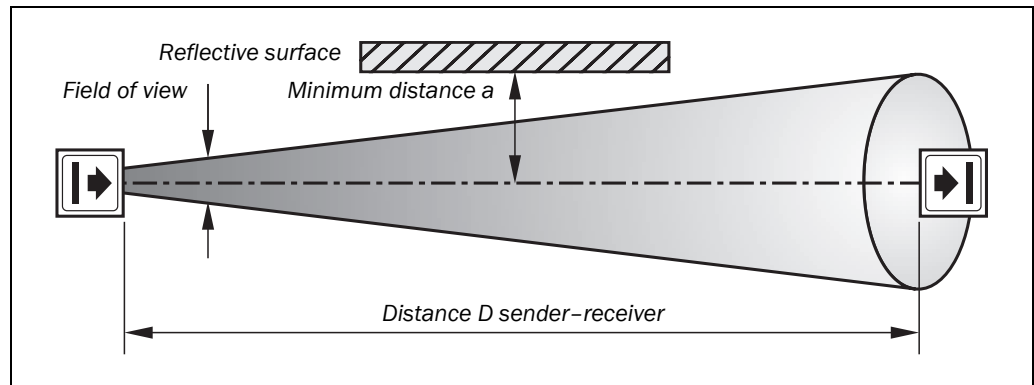

Note The field of view of the sender and receiver optics is identical.

How to determine the minimum distance from reflective surfaces:

- Determine the distance D [m] sender-receiver.
- Calculate the minimum distance a [mm] using the related formula in Tab. 4.

Tab. 4: Formula for the calculation of the minimum distance to reflective surfaces

Distance D [m] sender-receiver	Calculation of the minimum distance a from reflective surfaces
$D \leq 3$ m	a [mm] = 131
$D > 3$ m	a [mm] = $\tan(2.5^\circ) \times 1000 \times D$ [m] = $43.66 \times D$ [m]

5.2 Steps for mounting the device

Note The information in this section **is additional** to the information in the related section of the original operating instructions.

**WARNING****Special features to note during mounting:**

- Observe the safety distance of the system during mounting. On this subject read chapter 5.1 "Determining the safety distance" on page 12.
- Mount the M4000 Curtain system so that it is not possible to stand behind, reach under, reach over or to move the system.

Fig. 8: The correct installation (above) must eliminate the errors (below) standing behind, reaching under and reaching over

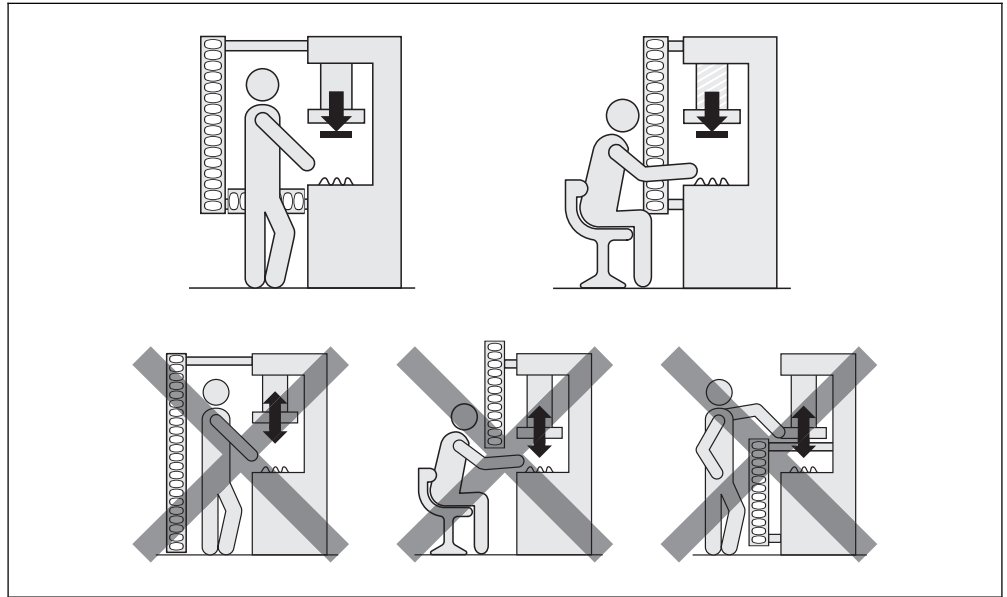

6 Commissioning

6.1 Alignment of the M4000 Curtain system

Note The information in this section **is additional** to the information in the related section of the original operating instructions.

The M4000 Curtain system is not available with integrated laser alignment aid. SICK recommends to use the laser alignment aid AR60 (see section “Alignment of the M4000” in the original operating instructions).

6.2 Test notes

Check the protective device as described below and in accordance with the applicable standards and regulations.

These tests are also used to identify if the protection is affected by external light sources or other unusual ambient effects.

These tests must therefore always be performed.

6.2.1 Daily functional checks of the protective device

Note The information in this section **replaces** the information in the related section of the original operating instructions.

The effectiveness of the protective device must be checked daily or prior to the start of work by a specialist or by authorised personnel, using the correct test rod.

How to check the effectiveness and correct function of the mounted protective device:

➤ Select the correct test rod depending on device resolution.



WARNING

Do not operate the machine if the green or yellow LED is lit during the test!

If the green or yellow LED lights up during the test even for a short period, work must stop at the machine. In this case the installation of the M4000 Curtain system must be checked by specialised personnel.

➤ **Prior** to covering each light beam with a test rod, check whether ...

- the green LED lights up on the M4000 Curtain system with de-activated internal restart interlock.
- the yellow LED lights up on the M4000 Curtain system with activated internal restart interlock (“Reset required”).

Note If this is not the case, ensure that this condition is reached. The test is otherwise meaningless.

➤ Move the test rod slowly through the area to be protected, as shown in ① in Fig. 9. Always test along the complete area to be protected, never solely at the mounting position of the M4000 Curtain system.

➤ Then, guide the test rod along the edges of the area to be protected, as shown in ② in Fig. 9. This procedure allows you to test if the point-of-operation guarding/reaching behind protection is functioning correctly (see 5.2 “Steps for mounting the device” on page 17).

➤ If you use one or more deflector mirrors, then also guide the test rod slowly through the area to be protected directly in front of the mirrors.

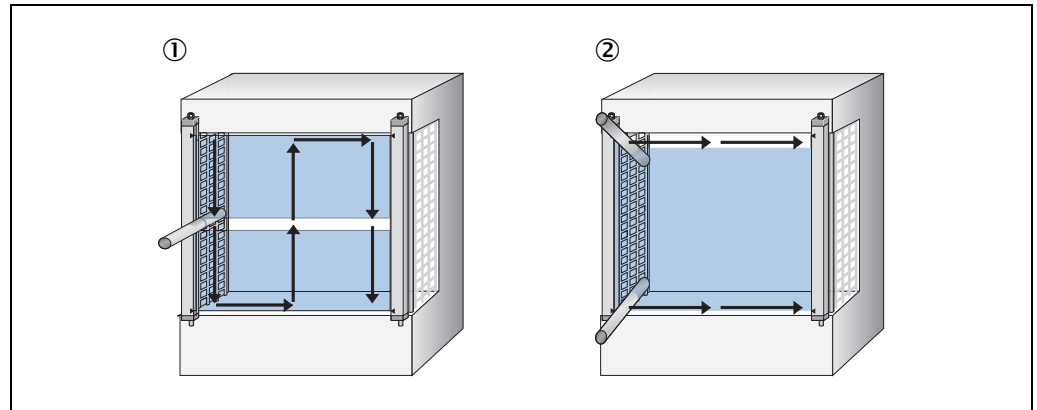
M4000 Std./Adv. Curtain*Fig. 9: Daily checks of the protective device***The check must produce the following result:**

- On the receiver for the related M4000 Curtain system only the red LED is allowed to illuminate and **not** the green or yellow LED

and

- as long as the light beam is interrupted, it must not be possible to initiate the dangerous state.

Further tests

- Check the protective device for damage or wear, particularly the mounting, the electrical connection and the connection cable, the housing and the front screen.
- Check whether the access to the hazardous area is only possible by interrupting the protective field for the M4000 Curtain system (e.g. correct mounting of mechanical protective devices).
- Check whether the protective device is effective for the set operating mode.

7 Technical specifications

7.1 Data sheet

Note The related data sheet in the original operating instructions applies to the M4000 Curtain system but with the following differences and additions:

Tab. 5: Data sheet M4000
Curtain system
(differences and additions
compared to the original
operating instructions)

Minimum	Typical	Maximum
---------	---------	---------

General system data

Type	Type 4 (IEC 61496-1, IEC 61496-2)		
Safety Integrity Level ³⁾	SIL3 (IEC 61508)		
SIL claim limit ³⁾	SILCL3 (EN 62061)		
Category	Category 4 (EN ISO 13849-1)		
Performance Level ³⁾	PL e (EN ISO 13849-1)		
PFHd (mean probability of a dangerous failure per hour)	28×10^{-9}		
T _M (mission time)	20 years (EN ISO 13849)		
Protective field height, depending on type	300 mm		1800 mm
Resolution d, depending on type	14 mm		30 mm
Protective field width			
Resolution 14 mm	0-8 m	0-10 m ⁴⁾	
Resolution 30 mm	0-19 m	0-21 m ⁴⁾	

☛ Sender

Power consumption			0.3 A
Weight, depending on type	See section 7.3 "Table of weights", page 21 ff.		

☛ Receiver

Power consumption			0.8 A ⁵⁾
Response time	See section 7.2 "Response time" on page 21.		
Weight, type-dependent	See section 7.3 "Table of weights", page 21 ff.		

³⁾ For detailed information on the exact design of your machine/system, please contact your local SICK representative.

⁴⁾ On the utilisation of this protective field width, it must be expected the orange LED will illuminate. The system then only has a reserve of 30%.

⁵⁾ Without OSSDs, without ADO, without Reset required and without UE403.

7.2 Response time

The response time depends on the following parameters:

- number of beams (The number of beams is defined by the resolution and the height of the protective field of the M4000 Curtain system.)
- beam coding

How to determine the response time of the system:

- Read the response time of the system from the type label. Note whether the system is operated with or without beam coding.

Note If you are planning the application without actually having any devices available, you can determine the response time using Tab. 6.

Tab. 6: Response time of the M4000 Curtain system as a function of the protective field height

Protective field height [mm]	Response time for physical resolution			
	Without beam coding		With beam coding	
	14 mm	30 mm	14 mm	30 mm
300	11 ms	10 ms	17 ms	12 ms
450	13 ms	10 ms	21 ms	14 ms
600	14 ms	11 ms	25 ms	15 ms
750	16 ms	11 ms	29 ms	17 ms
900	17 ms	12 ms	33 ms	18 ms
1050	19 ms	12 ms	36 ms	20 ms
1200	20 ms	13 ms	40 ms	21 ms
1350	21 ms	13 ms	44 ms	22 ms
1500	23 ms	14 ms	48 ms	24 ms
1650	24 ms	14 ms	52 ms	25 ms
1800	26 ms	15 ms	56 ms	27 ms

7.3 Table of weights

7.3.1 M4000 Curtain system

Tab. 7: Table of weights M4000 Curtain system

Protective field height S [mm]	Type code	Weight [g]
300	M40#-60A#####	1290
450	M40#-61A#####	1740
600	M40#-62A#####	2195
750	M40#-63A#####	2650
900	M40#-64A#####	3100
1050	M40#-65A#####	3555
1200	M40#-66A#####	4010
1350	M40#-67A#####	4456
1500	M40#-68A#####	4915
1650	M40#-69A#####	5370
1800	M40#-70A#####	5825

7.4 Dimensional drawings

7.4.1 M4000 Standard Curtain system

Fig. 10: Dimensional drawing M4000 Standard Curtain system (mm)

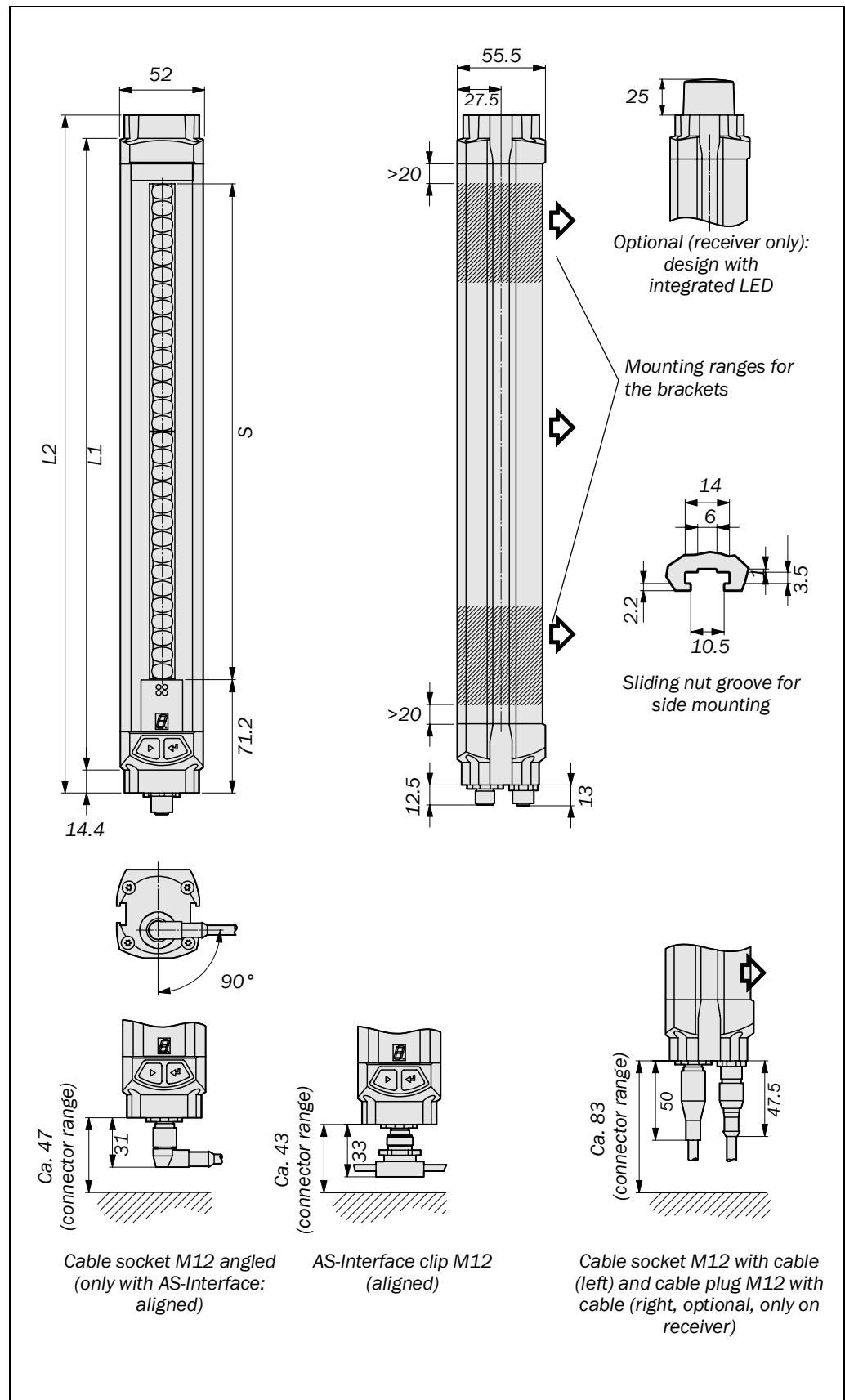

M4000 Std./Adv. Curtain

Tab. 8: Dimensions
depending on protective field
height, M4000 Standard
Curtain system

Protective field height S [mm]	Dimension L1 [mm]	Dimension L2 [mm]
300	387	416
450	537	566
600	687	716
750	837	866
900	987	1016
1050	1137	1166
1200	1287	1316
1350	1437	1466
1500	1587	1616
1650	1737	1766
1800	1887	1916

7.4.2 M4000 Advanced Curtain system

Fig. 11: Dimensional drawing M4000 Advanced Curtain system (mm)

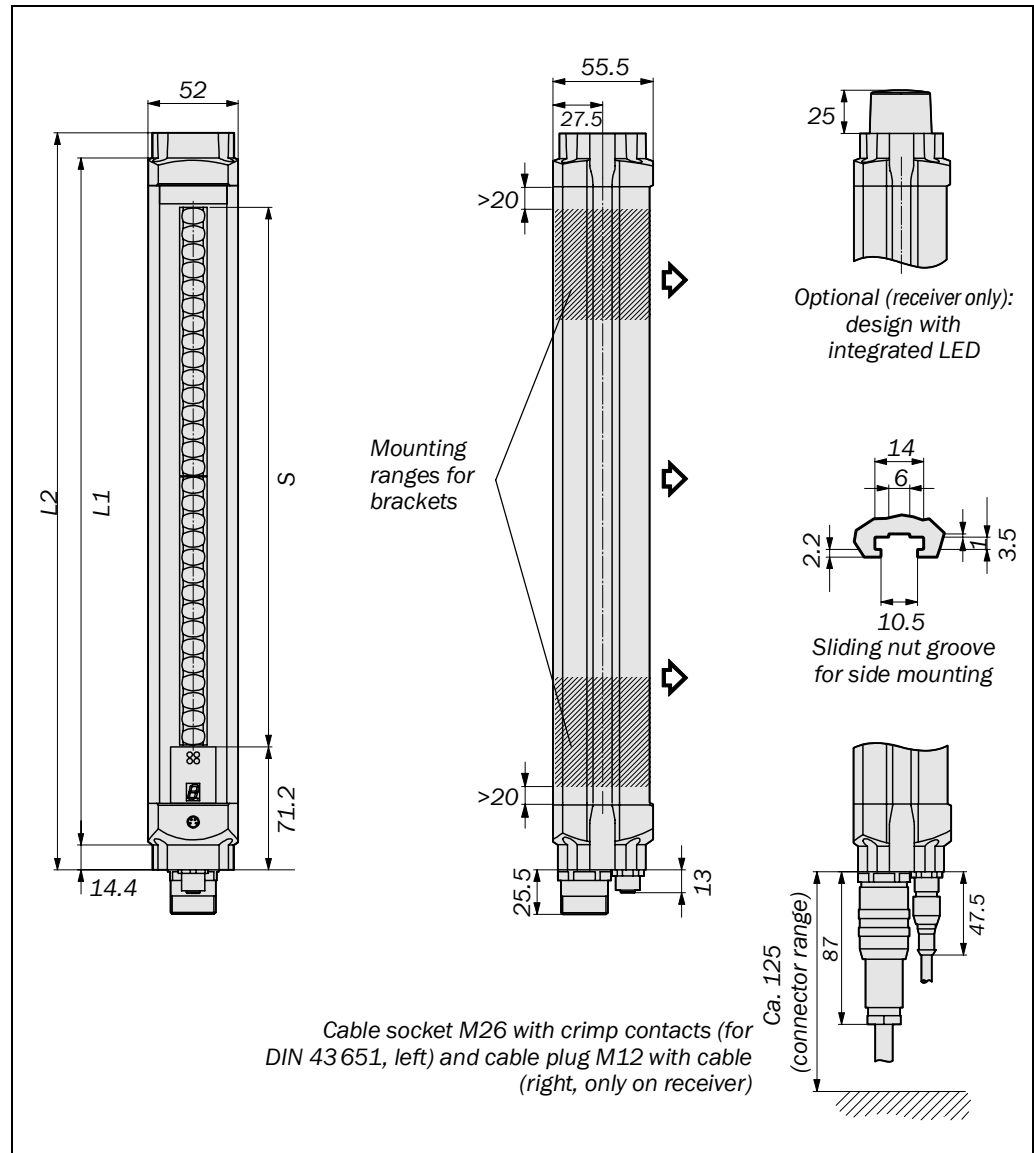

Tab. 9: Dimensions depending on protective field height, M4000 Advanced Curtain system

Protective field height S [mm]	Dimension L1 [mm]	Dimension L2 [mm]
300	387	416
450	537	566
600	687	716
750	837	866
900	987	1016
1050	1137	1166
1200	1287	1316
1350	1437	1466
1500	1587	1616
1650	1737	1766
1800	1887	1916

M4000 Std./Adv. Curtain

7.4.3 Deflector mirror PNS75

Fig. 12: Dimensional drawing deflector mirror PNS75 (mm)

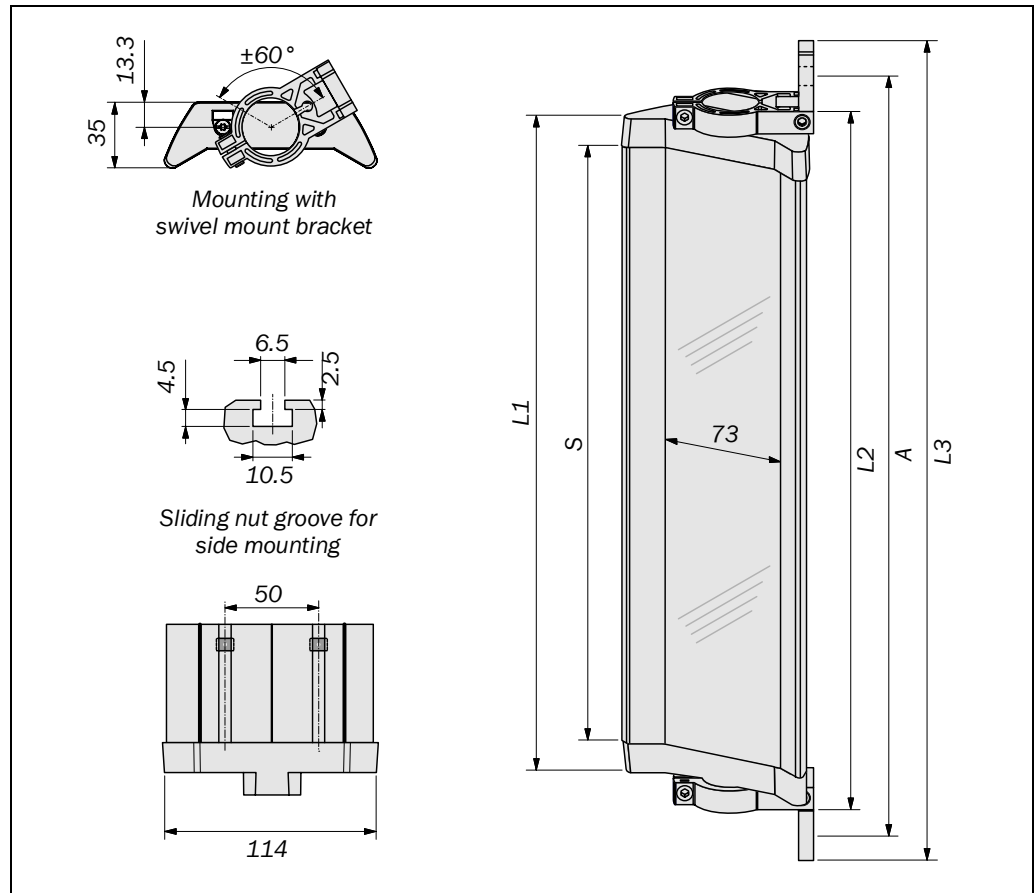

Tab. 10: Dimensions for the deflector mirror PNS75 depending on the mirror height

Mirror height S [mm]	Dimension L1 [mm]	Dimension L2 [mm]	Dimension L3 [mm]	Dimension A [mm]
340	372	396	460	440
490	522	546	610	590
640	672	696	760	740
790	822	846	910	890
940	972	996	1060	1040
1090	1122	1146	1210	1190
1240	1272	1296	1360	1340
1390	1422	1446	1510	1490
1540	1572	1596	1660	1640
1690	1722	1746	1810	1790
1840	1872	1896	1960	1940

- Notes**
- When using deflector mirrors, the effective scanning range is reduced (see section 4.1 “Scanning range” on page 10).
 - The formation of droplets of heavy contamination can be detrimental to the reflection behaviour. Take the necessary organisational measures to avoid the formation of droplets on the deflector mirrors.

7.4.4 Deflector mirror PNS125

Fig. 13: Dimensional drawing deflector mirror PNS125 (mm)

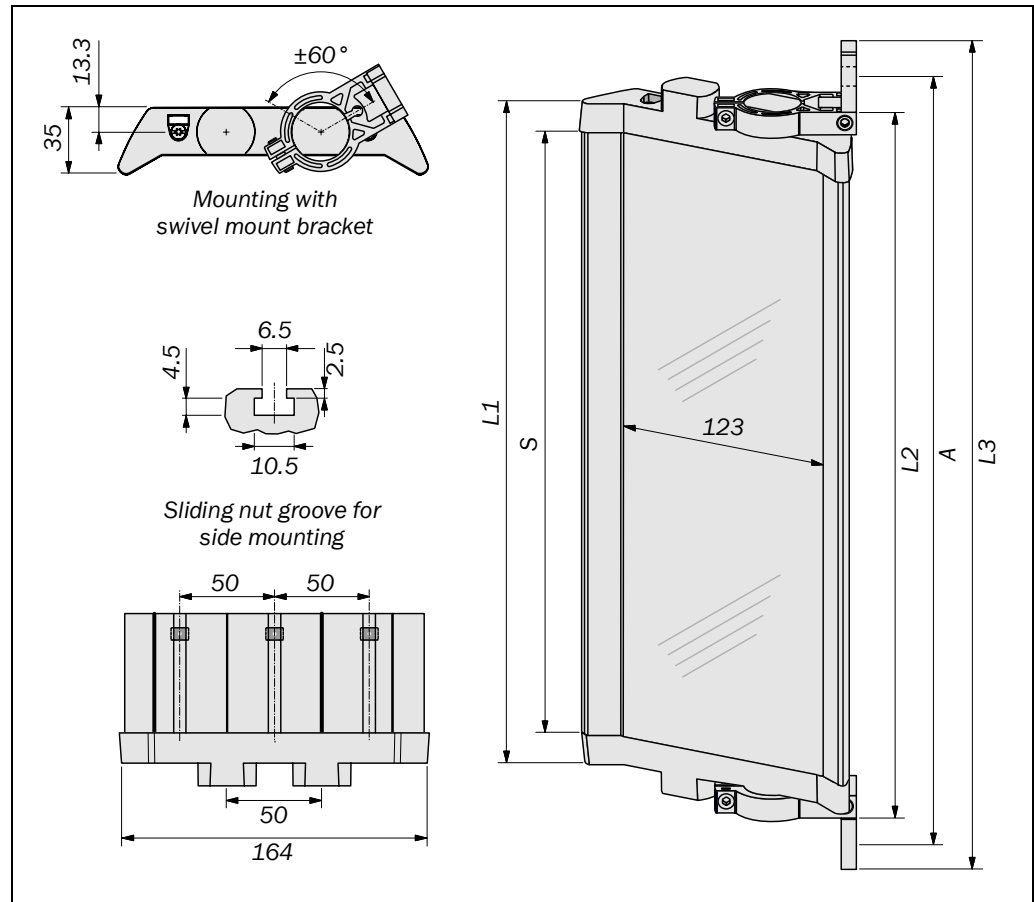

Tab. 11: Dimensions for the deflector mirror PNS125 depending on the mirror height

Mirror height S [mm]	Dimension L1 [mm]	Dimension L2 [mm]	Dimension L3 [mm]	Dimension A [mm]
340	372	396	460	440
490	522	546	610	590
640	672	696	760	740
790	822	846	910	890
940	972	996	1060	1040
1090	1122	1146	1210	1190
1240	1272	1296	1360	1340
1390	1422	1446	1510	1490
1540	1572	1596	1660	1640
1690	1722	1746	1810	1790
1840	1872	1896	1960	1940

- Notes**
- When using deflector mirrors, the effective scanning range is reduced (see section 4.1 “Scanning range” on page 10).
 - The formation of droplets of heavy contamination can be detrimental to the reflection behaviour. Take the necessary organisational measures to avoid the formation of droplets on the deflector mirrors.

8 Order data

8.1 M4000 Standard Curtain system

8.1.1 Type code

M4000 Standard Curtain system with 14 mm resolution and with M12 plug

Tab. 12: Type code M4000
Standard Curtain system
(14 mm) with M12 plug

Protective field height [mm]	Type code	
	☑ Sender	☑ Receiver
300	M40S-60A500ARO	M40E-60A500RRO
450	M40S-61A500ARO	M40E-61A500RRO
600	M40S-62A500ARO	M40E-62A500RRO
750	M40S-63A500ARO	M40E-63A500RRO
900	M40S-64A500ARO	M40E-64A500RRO
1050	M40S-65A500ARO	M40E-65A500RRO
1200	M40S-66A500ARO	M40E-66A500RRO
1350	M40S-67A500ARO	M40E-67A500RRO
1500	M40S-68A500ARO	M40E-68A500RRO
1650	M40S-69A500ARO	M40E-69A500RRO
1800	M40S-70A500ARO	M40E-70A500RRO

M4000 Standard Curtain system with 30 mm resolution and with M12 plug

Tab. 13: Type code M4000
Standard Curtain system
(30 mm) with M12 plug

Protective field height [mm]	Type code	
	☑ Sender	☑ Receiver
300	M40S-60A300ARO	M40E-60A300RRO
450	M40S-61A300ARO	M40E-61A300RRO
600	M40S-62A300ARO	M40E-62A300RRO
750	M40S-63A300ARO	M40E-63A300RRO
900	M40S-64A300ARO	M40E-64A300RRO
1050	M40S-65A300ARO	M40E-65A300RRO
1200	M40S-66A300ARO	M40E-66A300RRO
1350	M40S-67A300ARO	M40E-67A300RRO
1500	M40S-68A300ARO	M40E-68A300RRO
1650	M40S-69A300ARO	M40E-69A300RRO
1800	M40S-70A300ARO	M40E-70A300RRO

8.1.2 Default delivery status

- Notes**
- The pre-setting for the device configuration is termed the default delivery status. You can accept or change these pre-settings (see chapter “Configuration” in the original operating instructions).
 - The default delivery status is only applicable for the device types listed in section 8.1.1 “Type code”.

Tab. 14: Default delivery status M4000 Standard Curtain system

Function	Configuration	
	☑ Sender	☑ Receiver
Beam coding	Non-coded	Non-coded
Sender test	Deactivated	-
Restart interlock	-	Internal
External device monitoring (EDM)	-	Activated
Scanning range	-	Low scanning range
Application diagnostic output (ADO)	-	Contamination

8.2 M4000 Standard AS-i Curtain system

8.2.1 Type code

**M4000 Standard Curtain system
with 30 mm resolution and
with integrated AS-Interface Safety at Work**

Tab. 15: Type code M4000 Standard Curtain system (30 mm) with integrated AS-Interface Safety at Work

Protective field height [mm]	Type code	
	☒ Sender	☒ Receiver
300	M40S-60A302AU0	M40E-60A302AU0
450	M40S-61A302AU0	M40E-61A302AU0
600	M40S-62A302AU0	M40E-62A302AU0
750	M40S-63A302AU0	M40E-63A302AU0
900	M40S-64A302AU0	M40E-64A302AU0
1050	M40S-65A302AU0	M40E-65A302AU0
1200	M40S-66A302AU0	M40E-66A302AU0

8.2.2 Default delivery status

- Notes**
- The pre-setting for the device configuration is termed the default delivery status. You can accept or change these pre-settings (see chapter “Configuration” in the original operating instructions).
 - The default delivery status is only applicable for the device types listed in section 8.2.1 “Type code”.

Tab. 16: Default delivery status M4000 Standard AS-i Curtain system

Function	Configuration	
	☒ Sender	☒ Receiver
Beam coding	Non-coded	Non-coded
Scanning range	-	Low scanning range

8.3 M4000 Advanced Curtain system

8.3.1 Type code

**M4000 Advanced Curtain system
with 14 mm resolution and
with M26 Hirschmann plug and
M12 × 5 socket⁶⁾**

Tab. 17: Type code M4000
Advanced Curtain system
(14 mm) with M26
Hirschmann plug and
M12 × 5 socket

Protective field height [mm]	Type code	
	☑ Sender	☑ Receiver
300	M40S-60A503AA0	M40E-60A503RB0
450	M40S-61A503AA0	M40E-61A503RB0
600	M40S-62A503AA0	M40E-62A503RB0
750	M40S-63A503AA0	M40E-63A503RB0
900	M40S-64A503AA0	M40E-64A503RB0
1050	M40S-65A503AA0	M40E-65A503RB0
1200	M40S-66A503AA0	M40E-66A503RB0
1350	M40S-67A503AA0	M40E-67A503RB0
1500	M40S-68A503AA0	M40E-68A503RB0
1650	M40S-69A503AA0	M40E-69A503RB0
1800	M40S-70A503AA0	M40E-70A503RB0

**M4000 Advanced Curtain System
with 14 mm resolution and
with M26 Hirschmann plug and
with M12 × 5 socket⁶⁾ and
end cap with integrated LED⁷⁾**

Tab. 18: Type code M4000
Advanced Curtain system
(14 mm) with M26 plug,
M12 × 5 socket and end cap
with integrated LED

Protective field height [mm]	Type code	
	☑ Sender	☑ Receiver
300	M40S-60A503AA0	M40E-60A523RB0
450	M40S-61A503AA0	M40E-61A523RB0
600	M40S-62A503AA0	M40E-62A523RB0
750	M40S-63A503AA0	M40E-63A523RB0
900	M40S-64A503AA0	M40E-64A523RB0
1050	M40S-65A503AA0	M40E-65A523RB0
1200	M40S-66A503AA0	M40E-66A523RB0
1350	M40S-67A503AA0	M40E-67A523RB0
1500	M40S-68A503AA0	M40E-68A523RB0
1650	M40S-69A503AA0	M40E-69A523RB0
1800	M40S-70A503AA0	M40E-70A523RB0

⁶⁾ Receiver only: Extension connection for UE403.

⁷⁾ Receiver only.

M4000 Std./Adv. Curtain**M4000 Advanced Curtain system
with 30 mm resolution and
with M26 Hirschmann plug and
M12 × 5 socket⁸⁾**

Tab. 19: Type code M4000
Advanced Curtain system
(30 mm) with M26
Hirschmann plug and
M12 × 5 socket

Protective field height [mm]	Type code	
	☒ Sender	☒ Receiver
300	M40S-60A303AA0	M40E-60A303RB0
450	M40S-61A303AA0	M40E-61A303RB0
600	M40S-62A303AA0	M40E-62A303RB0
750	M40S-63A303AA0	M40E-63A303RB0
900	M40S-64A303AA0	M40E-64A303RB0
1050	M40S-65A303AA0	M40E-65A303RB0
1200	M40S-66A303AA0	M40E-66A303RB0
1350	M40S-67A303AA0	M40E-67A303RB0
1500	M40S-68A303AA0	M40E-68A303RB0
1650	M40S-69A303AA0	M40E-69A303RB0
1800	M40S-70A303AA0	M40E-70A303RB0

**M4000 Advanced Curtain system
with 30 mm resolution and
with M26 Hirschmann plug and
with M12 × 5 socket⁸⁾ and
end cap with integrated LED⁹⁾**

Tab. 20: Type code M4000
Advanced Curtain system
(30 mm) with M26 plug,
M12 × 5 socket and end cap
with integrated LED

Protective field height [mm]	Type code	
	☒ Sender	☒ Receiver
300	M40S-60A303AA0	M40E-60A323RB0
450	M40S-61A303AA0	M40E-61A323RB0
600	M40S-62A303AA0	M40E-62A323RB0
750	M40S-63A303AA0	M40E-63A323RB0
900	M40S-64A303AA0	M40E-64A323RB0
1050	M40S-65A303AA0	M40E-65A323RB0
1200	M40S-66A303AA0	M40E-66A323RB0
1350	M40S-67A303AA0	M40E-67A323RB0
1500	M40S-68A303AA0	M40E-68A323RB0
1650	M40S-69A303AA0	M40E-69A323RB0
1800	M40S-70A303AA0	M40E-70A323RB0

⁸⁾ Receiver only: Extension connection for UE403.

⁹⁾ Receiver only.

8.3.2 Default delivery status

- Notes**
- The pre-setting for the device configuration is termed the default delivery status. You can accept or change these pre-settings (see chapter “Configuration” in the original operating instructions).
 - The default delivery status is only applicable for the device types listed in section 8.3.1 “Type code”.

Tab. 21: Default delivery status M4000 Advanced Curtain system

Function	Configuration	
	☑ Sender	☑ Receiver
Beam coding	Non-coded	Non-coded
Sender test	Deactivated	-
Restart interlock	-	Internal
External device monitoring (EDM)	-	Activated
Scanning range	-	Low scanning range
Application diagnostic output (ADO)	-	Contamination

8.4 Additional front screens (weld spark guard)

Tab. 22: Part numbers additional front screens for the M4000 Curtain system

Description	Part number
Additional front screen for the M4000 Curtain system, including sliding nuts and fixing screws, 2 pieces, suitable for: M40#-60#####	2033235
M40#-61#####	2033236
M40#-62#####	2033237
M40#-63#####	2033238
M40#-64#####	2033239
M40#-65#####	2033240
M40#-66#####	2033241
M40#-67#####	2033242
M40#-68#####	2033243
M40#-69#####	2033244
M40#-70#####	2033245

- Notes**
- The additional front screens are bolted directly to the mounting groove on the M4000 Curtain system using the sliding nuts and fixing screws.
 - Each additional front screen fits both on the sender and on the receiver.
 - An additional front screen reduces the scanning range of the system by 8%. If an additional front screen is placed each on the sender and the receiver, the scanning range will be reduced by 16%.

8.5 Deflector mirror

- Notes**
- When using deflector mirrors, you **must** configure the multiple light beam safety device for a high scanning range.
 - The usage of deflector mirrors reduces the effective scanning range of the system. On this subject see section 4.1 “Scanning range” on page 10.
 - The formation of droplets of heavy contamination can be detrimental to the reflection behaviour. Take the necessary organisational measures to avoid the formation of droplets on the deflector mirrors.

8.5.1 Deflector mirror PNS75 for protective field width 0 ... 8 m (total)

Tab. 23: Part numbers deflector mirrors PNS75 for the M4000 Curtain system

Protective field height [mm]	Type code	Part number
300	PNS75-034	1019414
450	PNS75-049	1019415
600	PNS75-064	1019416
750	PNS75-079	1019417
900	PNS75-094	1019418
1050	PNS75-109	1019419
1200	PNS75-124	1019420
1350	PNS75-139	1019421
1500	PNS75-154	1019422
1650	PNS75-169	1019423
1800	PNS75-184	1019424

8.5.2 Deflector mirror PNS125 for protective field width 4 ... 17 m (total)

Tab. 24: Part numbers deflector mirrors PNS125 for the M4000 Curtain system

Protective field height [mm]	Type code	Part number
300	PNS125-034	1019425
450	PNS125-049	1019426
600	PNS125-064	1019427
750	PNS125-079	1019428
900	PNS125-094	1019429
1050	PNS125-109	1019430
1200	PNS125-124	1019431
1350	PNS125-139	1019432
1500	PNS125-154	1019433
1650	PNS125-169	1019434
1800	PNS125-184	1019435

9 Annex

9.1 List of tables

Tab. 1:	Guaranteed scanning ranges for the M4000 Curtain system as a function of the physical resolution	10
Tab. 2:	Effective scanning range of the M4000 Curtain system when using 1 or 2 deflector mirrors.....	10
Tab. 3:	Equations for calculating the safety distance S	15
Tab. 4:	Formula for the calculation of the minimum distance to reflective surfaces	16
Tab. 5:	Data sheet M4000 Curtain system	20
Tab. 6:	Response time of the M4000 Curtain system as a function of the protective field height.....	21
Tab. 7:	Table of weights M4000 Curtain system.....	21
Tab. 8:	Dimensions depending on protective field height, M4000 Standard Curtain system	23
Tab. 9:	Dimensions depending on protective field height, M4000 Advanced Curtain system	24
Tab. 10:	Dimensions for the deflector mirror PNS75 depending on the mirror height	25
Tab. 11:	Dimensions for the deflector mirror PNS125 depending on the mirror height	26
Tab. 12:	Type code M4000 Standard Curtain system (14 mm) with M12 plug	27
Tab. 13:	Type code M4000 Standard Curtain system (30 mm) with M12 plug	27
Tab. 14:	Default delivery status M4000 Standard Curtain system	28
Tab. 15:	Type code M4000 Standard Curtain system (30 mm) with integrated AS-Interface Safety at Work.....	29
Tab. 16:	Default delivery status M4000 Standard AS-i Curtain system	29
Tab. 17:	Type code M4000 Advanced Curtain system (14 mm) with M26 Hirschmann plug and M12 × 5 socket.....	30
Tab. 18:	Type code M4000 Advanced Curtain system (14 mm) with M26 plug, M12 × 5 socket and end cap with integrated LED.....	30
Tab. 19:	Type code M4000 Advanced Curtain system (30 mm) with M26 Hirschmann plug and M12 × 5 socket.....	31
Tab. 20:	Type code M4000 Advanced Curtain system (30 mm) with M26 plug, M12 × 5 socket and end cap with integrated LED.....	31
Tab. 21:	Default delivery status M4000 Advanced Curtain system	32
Tab. 22:	Part numbers additional front screens for the M4000 Curtain system.....	32
Tab. 23:	Part numbers deflector mirrors PNS75 for the M4000 Curtain system.....	33
Tab. 24:	Part numbers deflector mirrors PNS125 for the M4000 Curtain system.....	33

9.2 List of illustrations

Fig. 1:	Device components of the M4000 Curtain system	7
Fig. 2:	Hazardous point protection with a M4000 Curtain system	9
Fig. 3:	Hazardous area protection with a M4000 Curtain system	9
Fig. 4:	Access protection with a M4000 Curtain system	9
Fig. 5:	Safety distance from the hazardous point	13
Fig. 6:	Safety distance to the hazardous point for non-perpendicular approach	15
Fig. 7:	Minimum distance to reflective surfaces	16
Fig. 8:	The correct installation (above) must eliminate the errors (below) standing behind, reaching under and reaching over	17
Fig. 9:	Daily checks of the protective device	19
Fig. 10:	Dimensional drawing M4000 Standard Curtain system (mm)	22
Fig. 11:	Dimensional drawing M4000 Advanced Curtain system (mm)	24
Fig. 12:	Dimensional drawing deflector mirror PNS75 (mm)	25
Fig. 13:	Dimensional drawing deflector mirror PNS125 (mm)	26

Australia

Phone +61 3 9457 0600
1800 334 802 – tollfree
E-Mail sales@sick.com.au

Austria

Phone +43 (0)22 36 62 28 8-0
E-Mail office@sick.at

Belgium/Luxembourg

Phone +32 (0)2 466 55 66
E-Mail info@sick.be

Brazil

Phone +55 11 3215-4900
E-Mail marketing@sick.com.br

Canada

Phone +1 905 771 14 44
E-Mail information@sick.com

Czech Republic

Phone +420 2 57 91 18 50
E-Mail sick@sick.cz

Chile

Phone +56 2 2274 7430
E-Mail info@schadler.com

China

Phone +86 4000 121 000
E-Mail info.china@sick.net.cn

Denmark

Phone +45 45 82 64 00
E-Mail sick@sick.dk

Finland

Phone +358-9-2515 800
E-Mail sick@sick.fi

France

Phone +33 1 64 62 35 00
E-Mail info@sick.fr

Germany

Phone +49 211 5301-301
E-Mail info@sick.de

Great Britain

Phone +44 (0)1727 831121
E-Mail info@sick.co.uk

Hong Kong

Phone +852 2153 6300
E-Mail ghk@sick.com.hk

Hungary

Phone +36 1 371 2680
E-Mail office@sick.hu

India

Phone +91-22-4033 8333
E-Mail info@sick-india.com

Israel

Phone +972-4-6881000
E-Mail info@sick-sensors.com

Italy

Phone +39 02 27 43 41
E-Mail info@sick.it

Japan

Phone +81 (0)3 5309 2112
E-Mail support@sick.jp

Malaysia

Phone +603 808070425
E-Mail enquiry.my@sick.com

Netherlands

Phone +31 (0)30 229 25 44
E-Mail info@sick.nl

New Zealand

Phone +64 9 415 0459
0800 222 278 – tollfree
E-Mail sales@sick.co.nz

Norway

Phone +47 67 81 50 00
E-Mail sick@sick.no

Poland

Phone +48 22 837 40 50
E-Mail info@sick.pl

Romania

Phone +40 356 171 120
E-Mail office@sick.ro

Russia

Phone +7-495-775-05-30
E-Mail info@sick.ru

Singapore

Phone +65 6744 3732
E-Mail sales.gsg@sick.com

Slovakia

Phone +421 482 901201
E-Mail mail@sick-sk.sk

Slovenia

Phone +386 (0)1-47 69 990
E-Mail office@sick.si

South Africa

Phone +27 11 472 3733
E-Mail info@sickautomation.co.za

South Korea

Phone +82 2 786 6321
E-Mail info@sickkorea.net

Spain

Phone +34 93 480 31 00
E-Mail info@sick.es

Sweden

Phone +46 10 110 10 00
E-Mail info@sick.se

Switzerland

Phone +41 41 619 29 39
E-Mail contact@sick.ch

Taiwan

Phone +886 2 2375-6288
E-Mail sales@sick.com.tw

Thailand

Phone +66 2645 0009
E-Mail tawiwat@sicksgp.com.sg

Turkey

Phone +90 (216) 528 50 00
E-Mail info@sick.com.tr

United Arab Emirates

Phone +971 (0) 4 88 65 878
E-Mail info@sick.ae

USA/Mexico

Phone +1(952) 941-6780
1 (800) 325-7425 – tollfree
E-Mail info@sick.com

Vietnam

Phone +84 8 62920204
E-Mail Ngo.Duy.Linh@sicksgp.com.sg

More representatives and agencies
at www.sick.com