



Safe AGV Easy

SAFETY FOR AUTOMATED GUIDED VEHICLES MADE EASY

Functional safety systems

SICK
Sensor Intelligence.

END-TO-END SAFETY FOR AUTOMATED GUIDED VEHICLE SYSTEMS

✓ Modular expansion possible



✓ Economical



✓ Easy to integrate



✓ Gapless safety

✓ Complies with international standards

✓ Future-proof

Safe AGV Easy is the comprehensive end-to-end safety solution for automated guided vehicles and transport carts (AGVs and AGCs). The functional safety system implements the safety functions for collision avoidance and works reliably even under difficult ambient conditions such as dust. Integration is quick and easy because the Safe AGV Easy consists of tried-and-tested components in a compact design.

Safe AGV Easy primarily serves to protect employees, but also prevents damages to industrial vehicles or production machines. Compared to protection with bumpers, much higher speeds can be implemented with Safe AGV Easy. It is the easy and cost-effective solution for protecting your process and productivity in the long term.

SICK offers a wide range of products for the protection of automated guided vehicles and transport carts (AGVs and AGCs). Safe AGV Easy combines the most important products with a range of decisive advantages.

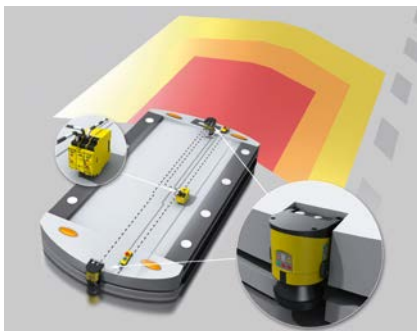

Safe AGV Easy is economical, easy to integrate and allows for modular expansion

With small transport vehicles and transport carts in particular, it is important to keep track of both the costs and the size of the safety solution. Safe AGV Easy consists of a safety laser scanner and a Flexi Classic safety controller or a safety relay. The system can also be easily mounted and expanded in the transport vehicle even if space is tight. Safe AGV Easy is therefore the right safety solution for any automated guided vehicle.



Safe AGV Easy offers end-to-end safety

The tried-and-tested safety components of the Safe AGV Easy ensure end-to-end safety of automated guided vehicles and transport carts. The safety laser scanner, combined with the Flexi Classic safety controller or a safety relay, detects people and objects in the path of the vehicle even under challenging application conditions, thereby reliably preventing collisions.



Safe AGV Easy fulfils international standards

The standards for safety solutions in automated guided vehicles vary from country to country. Due to international business relationships, increasing standardization and the strengthening of standards, however, requirements can grow quickly. With Safe AGV Easy, you are already on the safe side - the system consists of tried-and-tested and completely safe components which will also fulfill upcoming standards for modern safety systems.

Benefits at a glance

- ✓ Complete safety solution for automated guided vehicles and transport carts (AGVs and AGCs)
- ✓ Easy to integrate – consists of safety laser scanners and safety controller or safety relay in a compact design
- ✓ Can be used anywhere – flexible application due to expandable functions
- ✓ High reliability - even under difficult application conditions
- ✓ Reliable detection of people and obstacles located in the path of the vehicle







Safe AGV Easy OFFERS EXPANDABLE APPLICATION PACKAGES

A modular and application-specific solution package is available from Safe AGV Easy for applications which require different directions of travel, quick cornering or AGV docking processes. This way you only invest in the components you need. And should your requirements change, the Safe AGV Easy can be expanded flexibly at any time. This secures your investment and keeps your processes running.

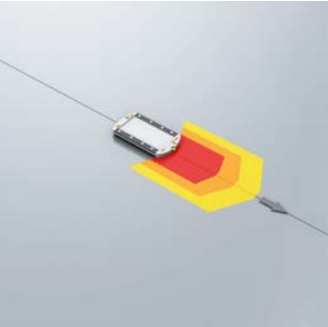
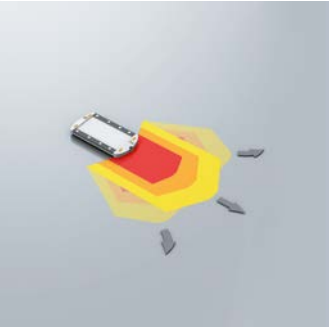
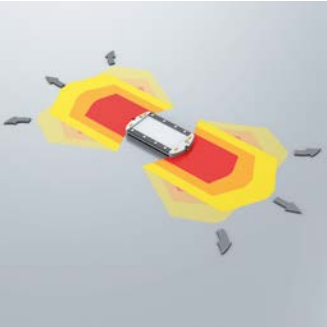
Safe AGV Easy is available in three variants. All are easy to integrate and offer reliable protection thanks to tried-and-tested safety components.

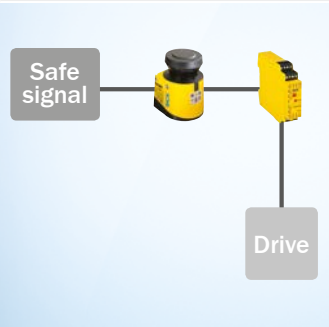

AGV transports motorcycle

	Safe AGV Easy 1	Safe AGV Easy 2	Safe AGV Easy 3
Type	SAPP03D-08A0005	SAPP03D-08A0006	SAPP03D-08A0007
Part number	1084027	1084028	1084029
			
Features			
Number of directions of travel	1	1	2
Switchable protective fields	●	●	●
Quick cornering	●	●	●
Docking process	●	●	●
			
Components			
Sensors	1 x safety laser scanner S300 Mini Standard	1 x safety laser scanner S300 Professional	2 x safety laser scanner S300 Professional
Logic	1 x safety relay UE48-30S	1 x safety controller Flexi Classic	1 x safety controller Flexi Classic
			
Integration example			
Safe signal	-	For switchable field sets	For switchable field sets

SAFETY FOR AUTOMATED GUIDED VEHICLES MADE EASY

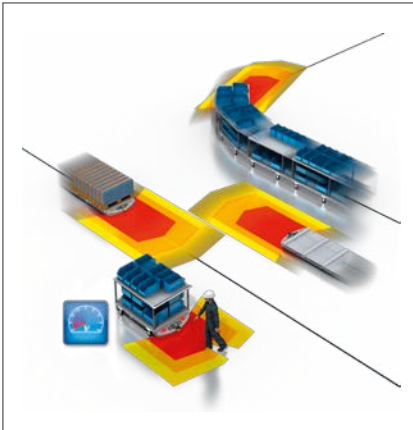

Additional information

Safe AGV Easy 1	
Detailed technical data	7
Ordering information	11
Dimensional drawings	11
Accessories	12
Dimensional drawings for accessories	14
Safe AGV Easy 2	
Detailed technical data	15
Ordering information	19
Dimensional drawings	20
Accessories	21
Dimensional drawings for accessories	23
Safe AGV Easy 3	
Detailed technical data	24
Ordering information	28
Dimensional drawings	29
Accessories	30
Dimensional drawings for accessories	33

Product description

Safe AGV Easy is the perfect safety solution for large and small automated guided vehicles and carts. Vehicles are made safe in an instant thanks to components that are easy to install and configure. The Safe AGV Easy safety system ensures safe, economical, and compliant vehicle operation.

This enables important logistics objectives, such as short throughput times, low stock levels, and high flexibility to be reliably achieved. The high reliability of the tried-and-tested SICK components increases availability and reduces follow-up costs.

At a glance

- Proven combination of reliable safety components
- Integration into all common field-buses
- Easy-to-configure fields and functions
- Compact design
- 270° scanning angle of the safety laser scanner
- Modular expansion module

Your benefits

- Easy handling reduces costs and integration work
- Ideal for mobile applications thanks to easy installation, commissioning, and maintenance
- Decades of proven safety technology for maximum reliability and availability – even under difficult conditions
- Fewer downtimes thanks to automated restart
- End-to-end safety thanks to a combination of safety laser scanners with safety controller or relay

→ www.sick.com/Safe_AGV_Easy

For more information, simply enter the link or scan the QR code and get direct access to technical data, CAD design models, operating instructions, software, application examples, and much more.



Safe AGV Easy 1

Detailed technical data

S300 Mini Standard

Features

Protective field range	3 m
Warning field range	8 m (at 15 % reflectivity)
Distance measuring range	30 m
Type of field set	Triple field sets
Number of field sets	1
Number of fields	3
Number of monitoring cases	1
Scanning angle	270°
Resolution	30 mm, 40 mm, 50 mm, 70 mm, 150 mm, configurable
Used resolution	70 mm
Angular resolution	0.5°
Response time	80 ms ¹⁾
Protective field supplement	100 mm
Number of multiple samplings	2 ... 16, configurable
Delay of automatic reset	2 s ... 60 s, configurable

¹⁾ Depending on basic response time and multiple sampling.

Safety-related parameters

Type	Type 3 (IEC 61496)
Safety integrity level	SIL2 (IEC 61508) SILCL2 (EN 62061)
Category	Category 3 (EN ISO 13849)
Performance level	PL d (EN ISO 13849)
PFH_D (mean probability of a dangerous failure per hour)	8.0 x 10 ⁻⁸ (EN ISO 13849)
T_M (mission time)	20 years (EN ISO 13849)
Safe state in the event of a fault	At least one OSSD is in the OFF state.

Functions

Restart interlock	✓
External device monitoring (EDM)	✓
Multiple sampling	✓
Contour as a reference	✓

Interfaces

Connection type	Cable, 250 mm, with male connector M12, 8-pin
Universal I/Os	2
Inputs	
External device monitoring (EDM)	1 ¹⁾
Reset/restart	1 ¹⁾
Standby	1 ¹⁾
Outputs	
Safety outputs (OSSD)	2
Outputs for warning field	2 ¹⁾
Reset required	1 ¹⁾
Configuration method	PC with CDS (Configuration and Diagnostic Software)
Configuration interface	M8, 4-pin

¹⁾ Availability depends on the configuration of the universal I/Os.

Electrical data

Protection class	III (EN 50178, EN 60950)
Supply voltage V_s	24 V DC (16.8 V DC ... 30 V DC)
Power consumption	$\leq 0.25 \text{ A}^{1)}$ $\leq 1.35 \text{ A}^{2)}$

¹⁾ At 24 V DC without output load.

²⁾ At 24 V DC including maximum output load.

Mechanical data

Dimensions (W x H x D)	102 mm x 116 mm x 105 mm
Weight	0.8 kg, without connecting cables
Housing material	Aluminum die cast
Housing color	RAL 1021 (yellow), RAL 9005 (black)
Optics cover material	Polycarbonat
Optics cover surface finish	Outside with scratch-resistant coating

Ambient data

Enclosure rating	IP65 (EN 60529)
Ambient operating temperature	-10 °C ... +50 °C
Storage temperature	-25 °C ... +50 °C
Vibration resistance	5 g, 10 Hz ... 150 Hz (IEC 61496-1, IEC 61496-3)
Shock resistance	
Continuous shock	10 g, 16 ms (IEC 61496-1, IEC 61496-3)
Single shock	15 g, 11 ms (IEC 61496-1, IEC 61496-3)

Other information

Type of light	Pulsed laser diode
Wave length	905 nm
Detectable remission	1.8 % ... > 1,000 % (reflectors)
Laser class	1 (21 CFR 1040.10 and 1040.11, IEC 60825-1)

UE48-30S

Safety-related parameters

Safety integrity level	SIL3 (IEC 61508) SILCL3 (EN 62061)
Category	Category 4 (EN ISO 13849)
Performance level	PL e (EN ISO 13849)
B_{10d} parameter	1.26 x 10 ⁶ switching cycles (AC-15, 230 V, I = 1.5 A) 5.9 x 10 ⁶ switching cycles (AC-15, 230 V, I = 0.75 A) 4.35 x 10 ⁵ switching cycles (DC-13, 24 V, I = 2.5 A) 1 x 10 ⁷ switching cycles (DC-13, 24 V, I = 0.63 A)
PFH_D (mean probability of a dangerous failure per hour)	3.0 x 10 ⁻⁸ (EN ISO 13849)
T_M (mission time)	20 years (EN ISO 13849)
Stop category	0 (EN 60204-1)

Interfaces

Connection type	Fixed screw terminals
Conductor cross-section	
Single wire (2x, same cross-section)	0.14 mm ² ... 0.75 mm ²
Fine wire with ferrules (2x, same cross-section)	0.2 mm ² ... 0.5 mm ²
Fine wire with ferrules (1x)	0.25 mm ² ... 2.5 mm ²

Electrical data

Operating data

Voltage supply	A1, A2
Output circuit > 25 V AC / 60 V DC	PELV
Output circuit ≤ 25 V AC / 60 V DC	PELV or SELV
Supply voltage V_s	A1, A2 24 V AC (21.6 V AC ... 26.4 V AC) 24 V DC (20.4 V DC ... 26.4 V DC)
Residual ripple	≤ 2.4 V _{pp} ¹⁾
Power consumption	5.0 VA (AC) 2.6 W (DC)
Overvoltage category	II
Rated insulation voltage U_i	300 V AC
Rated impulse withstand voltage U_{imp}	4 kV (EN 60664-1)
Test voltage	2 kV (50 Hz) (EN 60439-1)

¹⁾ In DC operation, within the limits of V_s.

Control voltage: S11, S21

Control voltage	22 V DC (≥ 17.4 V DC)
Control current	40 mA ... 100 mA
Short-circuit current	≤ 300 mA, between S33 / S11 and S21
Short-circuit protection	Electronic fuse

Input circuits: S12, S31, S22, S34, S35

Input voltage	HIGH	17.4 V DC ... 26.4 V DC
	LOW	-3 V DC ... 5 V DC
Input current	S12, S31/S22	≤ 100 mA
	S34/S35	≤ 50 mA
Reset time	Manual	≤ 40 ms
	Automatic	≤ 80 ms
Activation time of reset button		≥ 50 ms
Test pulse width		≤ 1,000 μs
Test pulse rate		≤ 10 Hz
Cable resistance		≤ 35 Ω

Electrical output circuits: 13/14, 23/24, 33/34

Response time		≤ 25 ms ¹⁾
Number of enable current (N/O) contacts		3, relevant for safety
Contact type		Positively driven
Contact material		Silver alloy, gold flashed
Switching voltage	Enable current contact	10 V AC ... 230 V AC / 10 V DC ... 300 V DC
Switching current	Enable current contact	10 mA ... 6 A
	Total current	≤ 12 A
Usage category		AC-15/DC-13 (EN 60947-5-1)
Rated operating current (voltage)		4 A (230 V AC) 360 switching cycles/h
		3 A (230 V AC) 3600 switching cycles/h
		4 A (24 V DC) 360 switching cycles/h
		2.5 A (24 V DC) 3600 switching cycles/h
Switching frequency		≤ 3600/h
Mechanical life (relay contacts)		1 x 10 ⁷ switching cycles

¹⁾ K1/K2.

Mechanical data

Dimensions (W x H x D)	22.5 mm x 114 mm x 96.5 mm
Weight	0.21 kg

Ambient data

Enclosure rating	Terminals	IP20 (EN 60529)
	Housing	IP40 (EN 60529)
Interference emission		EN 61000-6-4
Interference resistance		EN 61000-6-2

Ordering information

Items supplied Safe AGV Easy 1:

- Safe AGV Easy operating instructions for download → www.sick.com/Safe_AGV_Easy
- S300 Mini Standard safety laser scanner with cable, 0.25 m, male connector M12, 8-pin
- S300 Mini Standard operating instructions and CDS (Configuration & Diagnostic Software) on DVD
- S300 Mini Standard adhesive label with information on the daily check
- UE48-30S safety relay
- UE48-30S operating instructions as hard copy

Description	Type	Part no.
Safe AGV Easy 1	SAPP03D-08A0005	1084027

Dimensional drawings (Dimensions in mm (inch))

Laser scanner

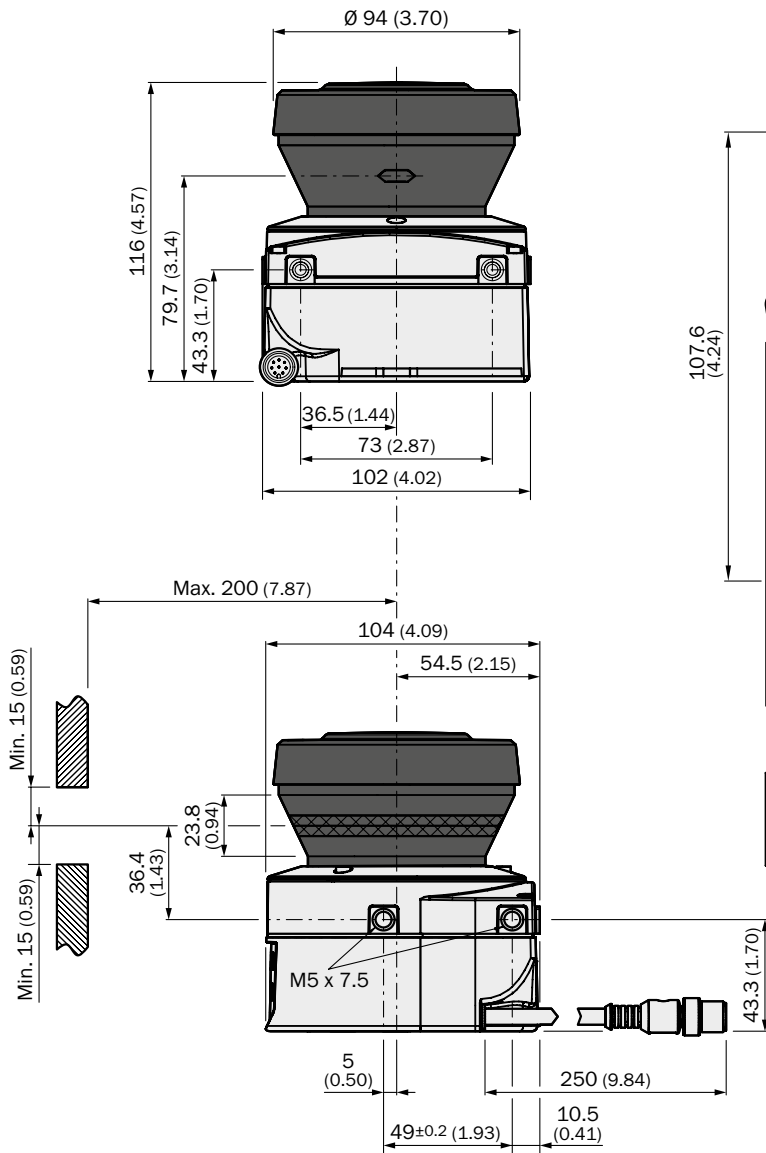

Safety relay

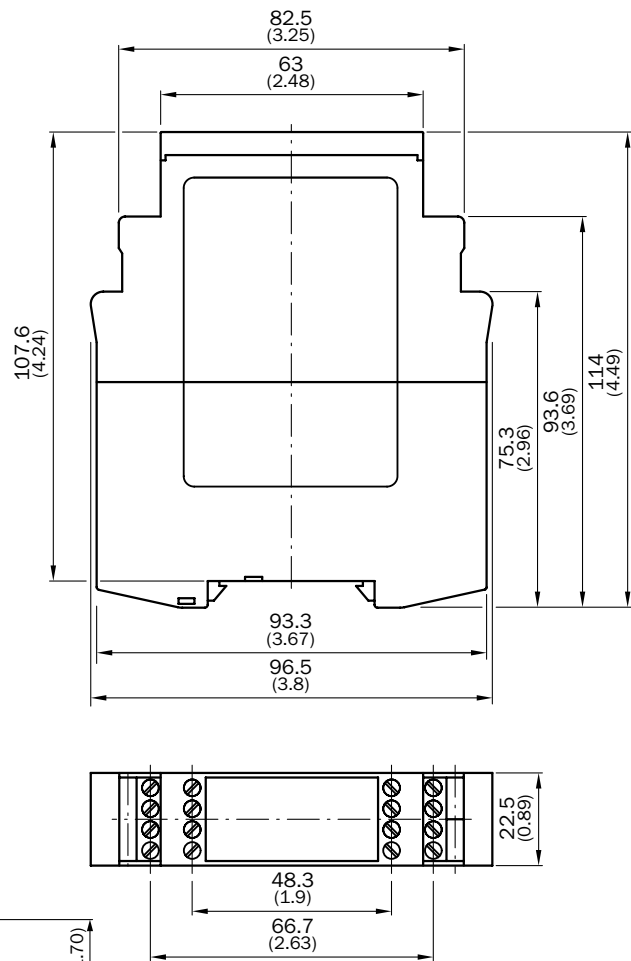

Accessories required for commissioning





Description	Number	Items supplied	Further information
Safe AGV Easy: Operating instructions	1	-	→ www.sick.com/Safe_AGV_Easy
S300 Mini Standard: Mounting bracket	1	-	→ Mounting brackets and mounting plates
S300 Mini Standard: Connecting cable	1	-	→ Plug connectors and cables
S300 Mini Standard: Connection cable for configuration and diagnosis	1	-	→ Plug connectors and cables
S300 Mini Standard: CDS (Configuration & Diagnostic Software)	1	✓	-
S300 Mini Standard: Operating instructions	1	✓	-
UE48-30S: Operating instructions	1	✓	-

Accessories

Mounting systems

Mounting brackets and mounting plates

Mounting brackets



Figure	Description	Packing unit	Type	Part no.
	Mounting bracket for rear mounting on wall or machine	1 piece	Mounting kit 1a	2034324
	Mounting bracket for rear mounting on wall or machine with protection of optics hood	1 piece	Mounting kit 1b	2034325
	Mounting bracket, adjustable lateral axis, only in conjunction with mounting kit 1a (2034324) or 1b (2034325)	1 piece	Mounting kit 2	2039302
	Mounting plate, adjustable longitudinal axis, only in conjunction with mounting kit 2 (2039302)	1 piece	Mounting kit 3	2039303

Dimensional drawings → [page 14](#)

Connection systems

Plug connectors and cables

Connecting cables with female connector

Figure	Connection type		Model	Conductor cross-section	Cable length	Type	Part no.
	Female connector, M12, 8-pin, straight	Cable	PUR, halogen-free, shielded	0.25 mm ²	2.5 m	DOL-127SG2M5E25KM0	2076540
					5 m	DOL-127SG05ME25KM0	2076541
					7.5 m	DOL-127SG7M5E25KM0	2076542
					10 m	DOL-127SG10ME25KM0	2076543
	Female connector, M12, 8-pin, angled	Cable	PUR, halogen-free, shielded	0.25 mm ²	5 m	DOL-127SW05ME25KM0	2076548
					7.5 m	DOL-127SW7M5E25KM0	2076549
					10 m	DOL-127SW10ME25KM0	2076550

Connection cables with male and male connector

- **Model:** PVC, unshielded

Figure	Connection type		Description	Conductor cross-section	Cable length	Type	Part no.
	Male connector, M8, 4-pin, straight	Male connector, USB-A, straight	For connecting the configuration connection to the USB interface on the PC	0.25 mm ²	2 m	DSL-8U04G02M025KM1	6034574
					10 m	DSL-8U04G10M025KM1	6034575

Power supply units and power cord connectors

Figure	Input voltage	Output voltage	Output current	Type	Part no.
 Illustration may differ	100 V AC ... 240 V AC	24 V DC	≤ 2.1 A	PS50WE24V	7028789
			≤ 3.9 A	PS95WE24V	7028790

Further accessories

Test and monitoring tools

Figure	Description	Type	Part no.
 Illustration may differ	Scan finder, receiver to localize infrared scans	Scan-Finder LS-80L	6020756

Spare parts

Figure	Description	Type	Part no.
	Spare part set optics cover with replacement seal and screws	Spare parts set optics cover S100/S300/S300 Mini	2039248

Dimensional drawings for accessories (Dimensions in mm (inch))

Mounting brackets and mounting plates

Mounting kit 1a

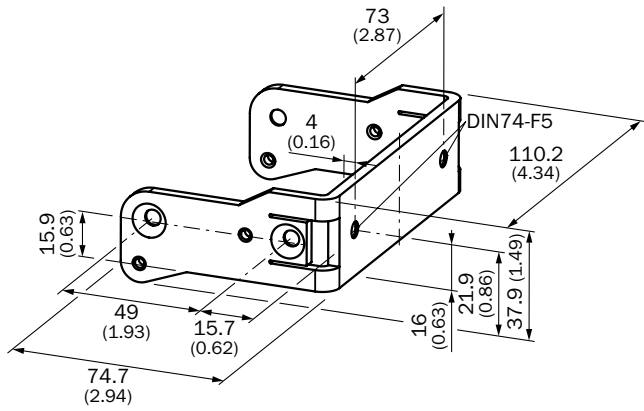

Mounting kit 1b

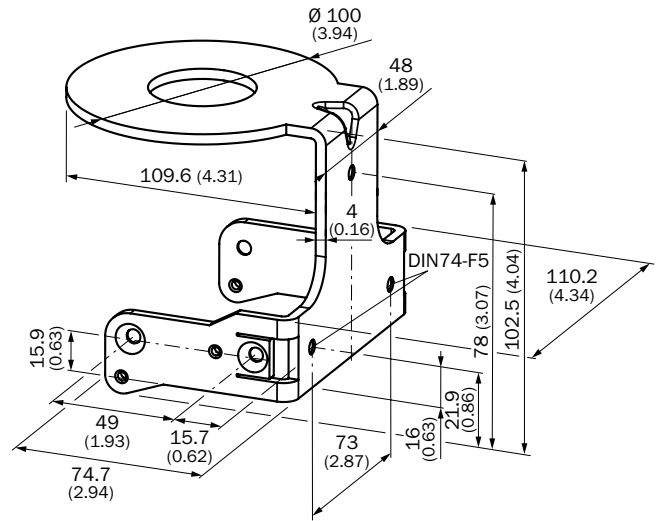

Mounting kit 2

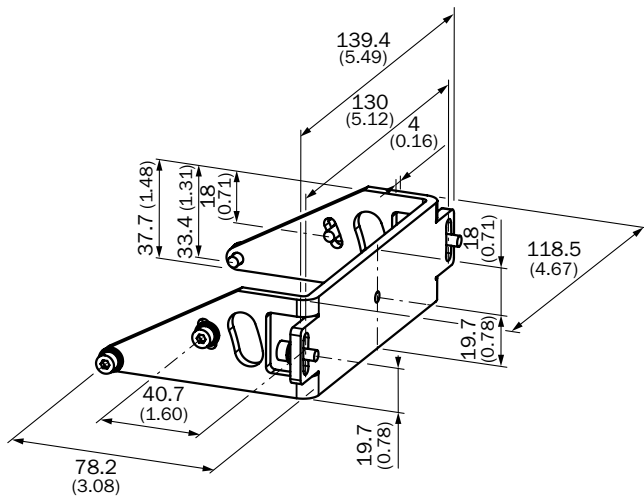

Mounting kit 3

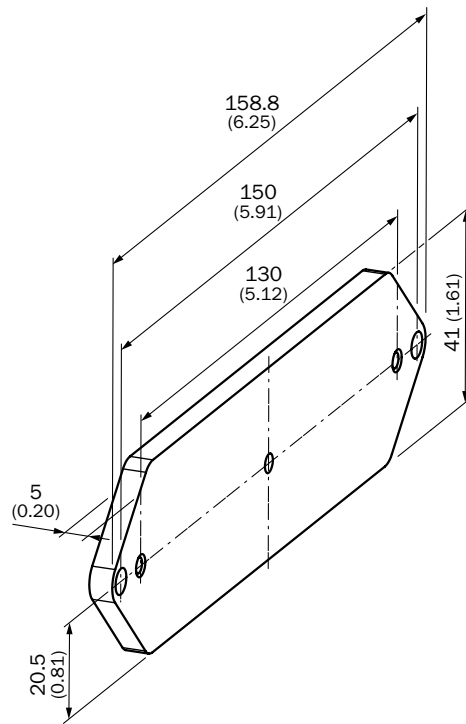

Safe AGV Easy 2

Detailed technical data

S300 Professional

Features

Protective field range	3 m
Warning field range	8 m (at 15 % reflectivity)
Distance measuring range	30 m
Type of field set	Triple field sets
Number of field sets	8
Number of fields	24
Number of monitoring cases	32 ¹⁾
Scanning angle	270°
Resolution	30 mm, 40 mm, 50 mm, 70 mm, 150 mm, configurable
Used resolution	70 mm
Angular resolution	0.5°
Response time	80 ms ²⁾
Protective field supplement	100 mm
Number of multiple samplings	2 ... 16, configurable
Delay of automatic reset	2 s ... 60 s, configurable

¹⁾ In combination with an additional static input via EFI or using the dynamic inputs on the device. Otherwise eight.

²⁾ Depending on basic response time and multiple sampling.

Safety-related parameters

Type	Type 3 (IEC 61496)
Safety integrity level	SIL2 (IEC 61508) SILCL2 (EN 62061)
Category	Category 3 (EN ISO 13849)
Performance level	PL d (EN ISO 13849)
PFH_D (mean probability of a dangerous failure per hour)	8.0 x 10 ⁻⁸ (EN ISO 13849)
T_M (mission time)	20 years (EN ISO 13849)
Safe state in the event of a fault	At least one OSSD is in the OFF state.

Functions

Restart interlock	✓
External device monitoring (EDM)	✓
Multiple sampling	✓
Monitoring case switching	✓
Static protective field switching	✓
Dynamic protective field switching	✓
Contour as a reference	✓
Integrated configuration memory	✓
Measured data output	✓
Safe SICK device communication via EFI	✓

Interfaces

Connection type	System plug with connecting cable, 10 m, 15-wire, unshielded, flying leads
Universal I/Os	5 ¹⁾
Inputs	
External device monitoring (EDM)	1 ²⁾
Reset/restart	1 ²⁾
Static control inputs	3 ³⁾
Static control inputs with EFI	5 ⁴⁾
Dynamic control inputs (incremental encoder)	2 ⁵⁾
Standby	1
Outputs	
OSSD pairs	1
Diagnostic outputs	3 ⁶⁾
Configuration method	PC with CDS (Configuration and Diagnostic Software)
Configuration interface	M8, 4-pin
Data interface	RS-422
Transmission rate	≤ 500 kBaud
Safe SICK device communication via EFI	
Transmission rate	≤ 500 kBaud
Cable length	≤ 50 m
Conductor cross-section	0.22 mm ²

¹⁾ Freely programmable, e.g., external device monitoring input, reset input, contamination warning, reset required.

²⁾ Availability depends on the configuration of the universal I/Os.

³⁾ 2+1; additional input is only available if reset and reset required are not being used.

⁴⁾ In combination with an EFI device (Flexi Soft or EFI gateway) five static control inputs are available. Otherwise three.

⁵⁾ Two of the static switching signals can be used either as dynamic or as static switching signals.

⁶⁾ Freely programmable, e.g. warning field, contamination, reset required.

Electrical data

Protection class	III (EN 50178, EN 60950)
Supply voltage V_s	24 V DC (16.8 V DC ... 30 V DC)
Power consumption	≤ 0.33 A ¹⁾ ≤ 1.7 A ²⁾
Outputs	
Safety outputs (OSSD)	2 x 250 mA
Diagnostic outputs	3 x 100 mA ³⁾

¹⁾ At 24 V DC without output load.

²⁾ At 24 V DC including maximum output load.

³⁾ Freely programmable, e.g. warning field, contamination, reset required.

Mechanical data

Dimensions (W x H x D)	102 mm x 152 mm x 106 mm
Weight	1.2 kg
Housing material	Aluminum die cast
Housing color	RAL 1021 (yellow)
Optics cover material	Polycarbonat
Optics cover surface finish	Outside with scratch-resistant coating

Ambient data

Enclosure rating	IP65 (EN 60529)
Ambient operating temperature	-10 °C ... +50 °C
Storage temperature	-25 °C ... +50 °C
Vibration resistance	5 g, 10 Hz ... 150 Hz (IEC 61496-1, IEC 61496-3)
Shock resistance	
Continuous shock	10 g, 16 ms (IEC 61496-1, IEC 61496-3)
Single shock	15 g, 11 ms (IEC 61496-1, IEC 61496-3)

Other information

Type of light	Pulsed laser diode
Wave length	905 nm
Detectable remission	1.8 % ... > 1,000 %, reflectors
Laser class	1 (21 CFR 1040.10 and 1040.11, IEC 60825-1)

Flexi Classic

Safety-related parameters

Safety integrity level	SIL3 (IEC 61508) SILCL3 (EN 62061)
Category	Category 4 (EN ISO 13849)
Performance level	PL e (EN ISO 13849)
PFH_D (mean probability of a dangerous failure per hour)	2.5 x 10 ⁻⁹ (EN ISO 13849)
T_M (mission time)	20 years (EN ISO 13849)

Functions

Restart interlock	Manual / automatic (configurable)
External device monitoring (EDM)	✓
AND operation	✓
OR operation	✓
Bypass	✓
Differentiation between man and material (muting)	✓

Interfaces

Inputs	4 safety inputs 4 switching inputs
Number of muting sensors	0 / 2
Outputs	4 safety outputs 2 test outputs
Delay time (outputs Q3/Q4)	0 s ... 5 s
Connection type	Plug-in screw-type terminals
Permitted cross-section	
Single wire or fine wire (1x)	0.14 mm ² ... 2.5 mm ²
Single wire or fine wire (2x)	0.14 mm ² ... 0.75 mm ²
Finely stranded with ferrules (1x)	0.25 mm ² ... 2.5 mm ²
Finely stranded with ferrules (2x)	0.25 mm ² ... 0.5 mm ²
Display elements	LEDs
Fieldbus, industrial network	CANopen DeviceNet™ EtherNet/IP™ Modbus TCP PROFIBUS DP PROFINET
Type of fieldbus integration	Flexi Classic gateway

Electrical data

Protection class	III (EN 61140)
Type of voltage supply	PELV or SELV ¹⁾
Supply voltage V_s	24 V DC (19.2 V DC ... 30 V DC)
Residual ripple	≤ 10 %
Power consumption	≤ 3 W (DC)
Switch-on time	≤ 60 s

¹⁾ The current of the power supply that powers the main unit must be limited to a maximum of 4 A, either through the power supply itself or a fuse.

Mechanical data

Dimensions (W x H x D)	22.5 mm x 96.5 mm x 120.8 mm
Weight	180 g

Ambient data

Enclosure rating	Housing	IP40 (EN 60529)
	Terminals	IP20 (EN 60529)
Ambient operating temperature	-25 °C ... +55 °C	
Storage temperature	-25 °C ... +70 °C	
Air humidity	10 % ... 95 %, non-condensing	
Climate conditions according to	EN 61131-2 (55 °C ambient operating temperature, 95% rel. humidity)	
Vibration resistance	5 g RMS, 5 Hz ... 500 Hz (EN 60068-2-64)	

Ordering information

Items supplied Safe AGV Easy 2:

- Safe AGV Easy operating instructions for download → www.sick.com/Safe_AGV_Easy
- S300 Professional safety laser scanner
- S300 Professional system plug with cable, 10 m, 15-wire, flying leads
- S300 Professional operating instructions and CDS (Configuration & Diagnostic Software) on DVD
- S300 Professional adhesive label with information on the daily check
- Flexi Classic main module
- Flexi Classic screw terminal connector
- Flexi Classic operating instructions for download → www.sick.com/Flexi_Classic

Description	Type	Part no.
Safe AGV Easy 2	SAPP03D-08A0006	1084028

Dimensional drawings (Dimensions in mm (inch))

Laser scanner

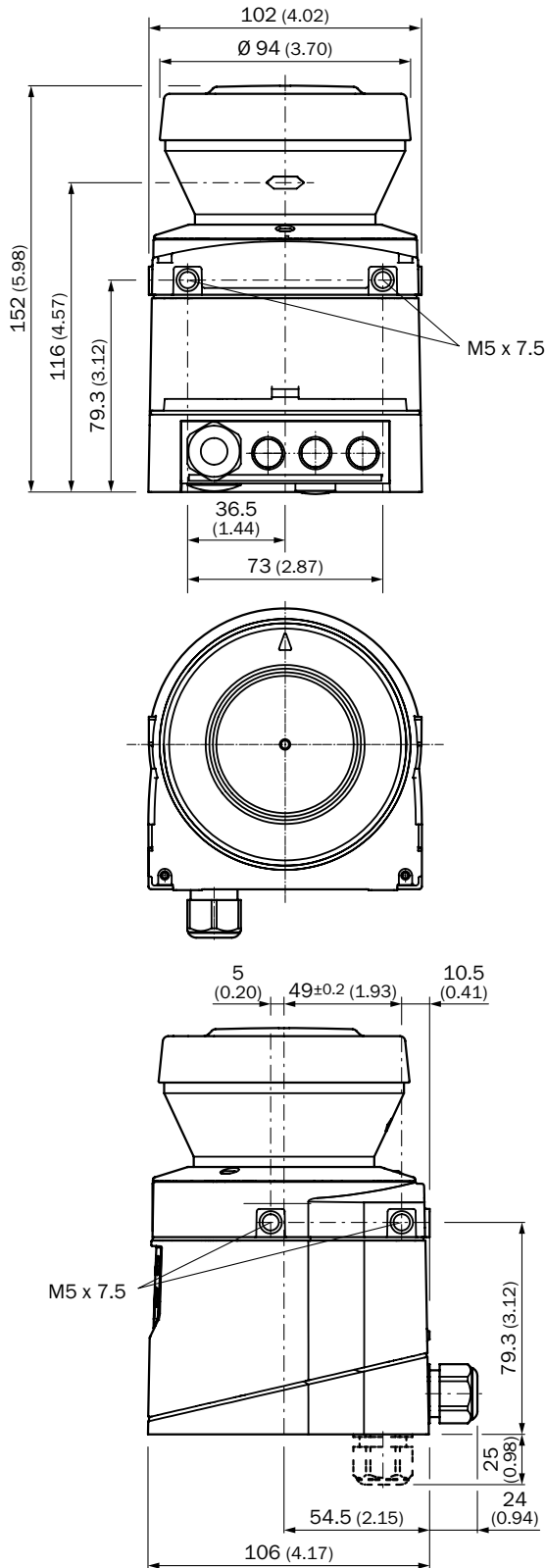

Flexi Classic main module

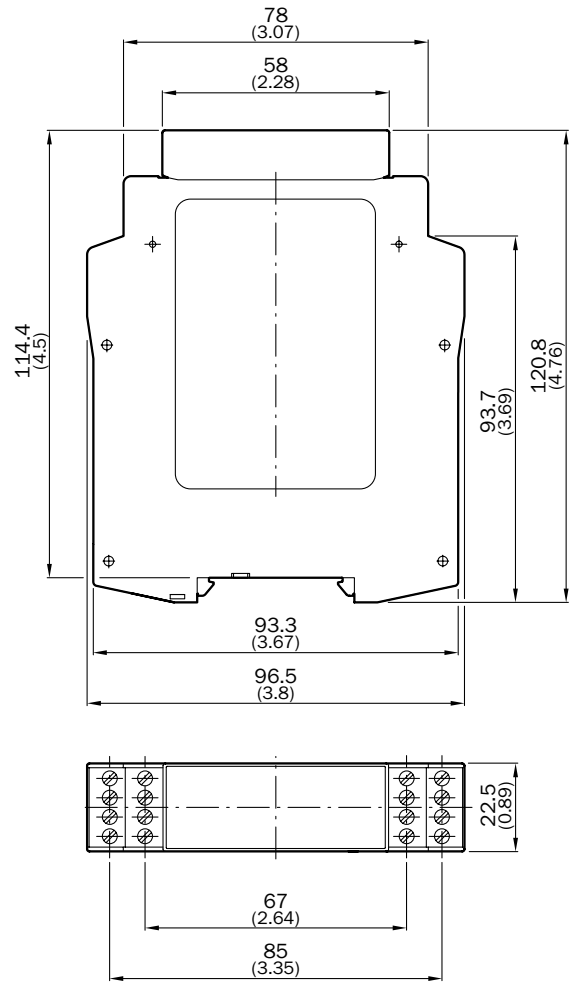

Accessories required for commissioning





Description	Number	Items supplied	Further information
Safe AGV Easy: Operating instructions	1	-	→ www.sick.com/Safe_AGV_Easy
S300 Professional: Mounting bracket	1	-	→ Mounting brackets and mounting plates
S300 Professional: System plug with connecting cable	1	✓	-
S300 Professional: Connection cable for configuration and diagnosis	1	-	→ Plug connectors and cables
S300 Professional: CDS (Configuration & Diagnostic Software)	1	✓	-
S300 Professional: Operating instructions	1	✓	-
Flexi Classic: Screw-terminal connector	1	✓	-
Flexi Classic: Operating instructions	1	-	→ www.sick.com/Flexi_Classic
UE48-30S (for switching current above 2 A and/or switching voltage above 24 V DC (up to 230 V AC))	0 / 1	-	→ Safety relays

Accessories

Mounting systems

Mounting brackets and mounting plates

Mounting brackets

Figure	Description	Packing unit	Type	Part no.
	Mounting bracket for rear mounting on wall or machine	1 piece	Mounting kit 1a	2034324
	Mounting bracket for rear mounting on wall or machine with protection of optics hood	1 piece	Mounting kit 1b	2034325
	Mounting bracket, adjustable lateral axis, only in conjunction with mounting kit 1a (2034324) or 1b (2034325)	1 piece	Mounting kit 2	2039302
	Mounting plate, adjustable longitudinal axis, only in conjunction with mounting kit 2 (2039302)	1 piece	Mounting kit 3	2039303

Dimensional drawings → [page 23](#)

Connection systems

Plug connectors and cables

Connection cables with male and male connector

- **Model:** PVC, unshielded

Figure	Connection type		Description	Conductor cross-section	Cable length	Type	Part no.
	Male connector, M8, 4-pin, straight	Male connector, USB-A, straight	For connecting the configuration connection to the USB interface on the PC	0.25 mm ²	2 m	DSL-8U04G02M025KM1	6034574
					10 m	DSL-8U04G10M025KM1	6034575

Power supply units and power cord connectors

Figure	Input voltage	Output voltage	Output current	Type	Part no.
 Illustration may differ	100 V AC ... 240 V AC	24 V DC	≤ 2.1 A	PS50WE24V	7028789
			≤ 3.9 A	PS95WE24V	7028790

Further accessories

Test and monitoring tools

Figure	Description	Type	Part no.
 Illustration may differ	Scan finder, receiver to localize infrared scans	Scan-Finder LS-80L	6020756

Spare parts

Figure	Description	Type	Part no.
	Spare part set optics cover with replacement seal and screws	Spare parts set optics cover S100/S300/S300 Mini	2039248

Safety relays

UE48-30S

Figure	Description	Number of enable current (N/O) contacts	Connection type	Type	Part no.
 Illustration may differ	Evaluation unit for safety sensors for switching current above 2 A and/or switching voltage above 24 V DC (up to 230 V AC)	3	Fixed screw terminals	UE48-30S2D2S1	1067636

Safety controllers

Flexi Classic

Figure	Module	Inputs	Outputs	Connection type	Type	Part no.
 Illustration may differ	Flexi Classic input extension	8 safety inputs	8 test outputs	Plug-in screw-type terminals	UE410-8DI3	6026139

Dimensional drawings for accessories (Dimensions in mm (inch))

Mounting brackets and mounting plates

Mounting kit 1a

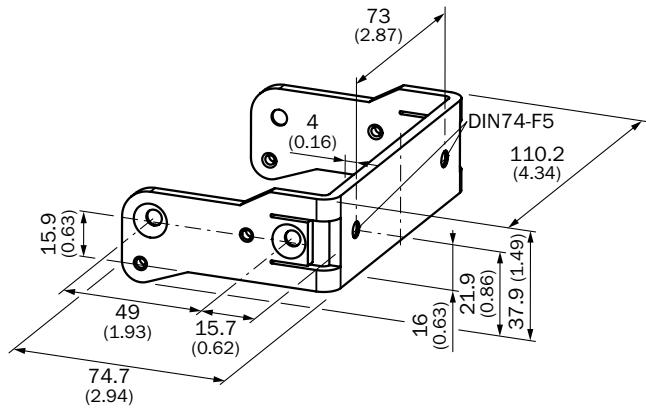

Mounting kit 1b

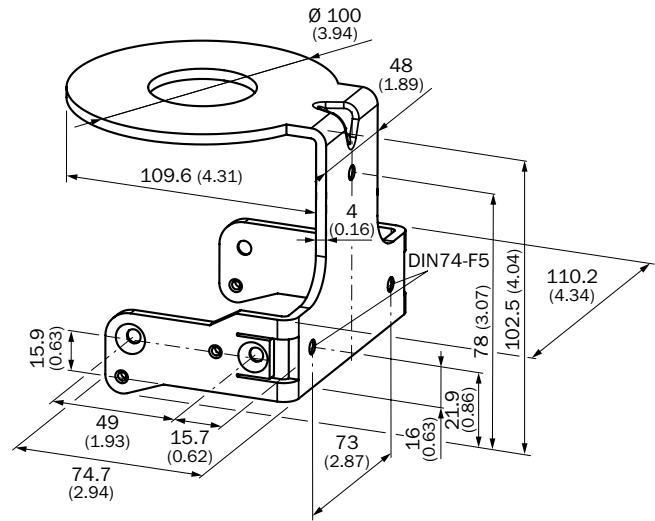

Mounting kit 2

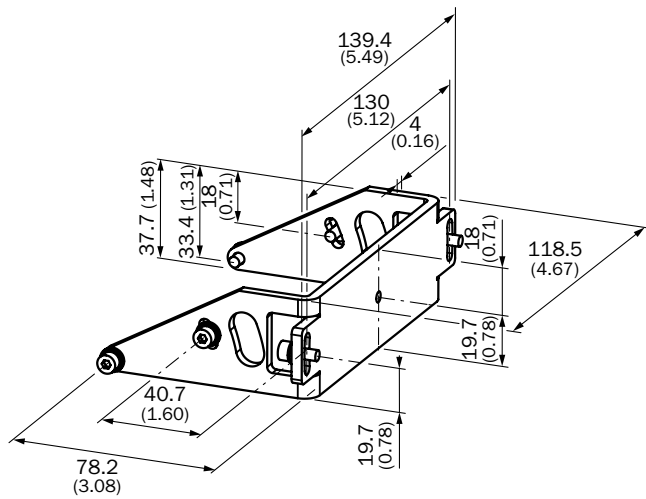

Mounting kit 3

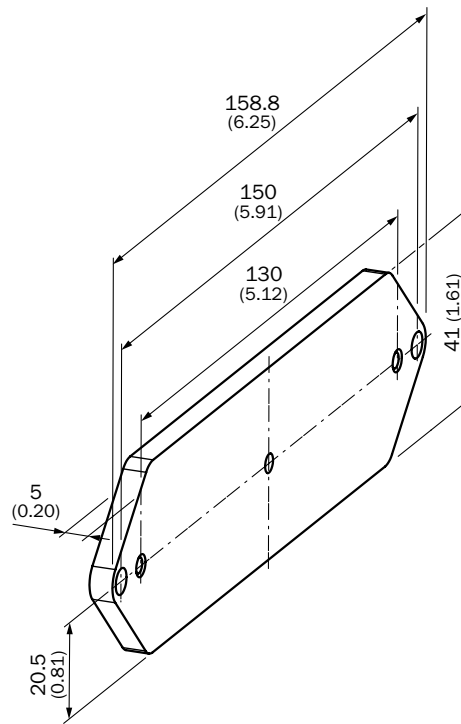

Safe AGV Easy 3

Detailed technical data

S300 Professional

Features

Protective field range	3 m
Warning field range	8 m (at 15 % reflectivity)
Distance measuring range	30 m
Type of field set	Triple field sets
Number of field sets	8
Number of fields	24
Number of monitoring cases	32 ¹⁾
Scanning angle	270°
Resolution	30 mm, 40 mm, 50 mm, 70 mm, 150 mm, configurable
Used resolution	70 mm
Angular resolution	0.5°
Response time	80 ms ²⁾
Protective field supplement	100 mm
Number of multiple samplings	2 ... 16, configurable
Delay of automatic reset	2 s ... 60 s, configurable

¹⁾ In combination with an additional static input via EFI or using the dynamic inputs on the device. Otherwise eight.

²⁾ Depending on basic response time and multiple sampling.

Safety-related parameters

Type	Type 3 (IEC 61496)
Safety integrity level	SIL2 (IEC 61508) SILCL2 (EN 62061)
Category	Category 3 (EN ISO 13849)
Performance level	PL d (EN ISO 13849)
PFH_D (mean probability of a dangerous failure per hour)	8.0 x 10 ⁻⁸ (EN ISO 13849)
T_M (mission time)	20 years (EN ISO 13849)
Safe state in the event of a fault	At least one OSSD is in the OFF state.

Functions

Restart interlock	✓
External device monitoring (EDM)	✓
Multiple sampling	✓
Monitoring case switching	✓
Static protective field switching	✓
Dynamic protective field switching	✓
Contour as a reference	✓
Integrated configuration memory	✓
Measured data output	✓
Safe SICK device communication via EFI	✓

Interfaces

Connection type	System plug with connecting cable, 10 m, 15-wire, unshielded, flying leads
Universal I/Os	5 ¹⁾
Inputs	
External device monitoring (EDM)	1 ²⁾
Reset/restart	1 ²⁾
Static control inputs	3 ³⁾
Static control inputs with EFI	5 ⁴⁾
Dynamic control inputs (incremental encoder)	2 ⁵⁾
Standby	1
Outputs	
OSSD pairs	1
Diagnostic outputs	3 ⁶⁾
Configuration method	PC with CDS (Configuration and Diagnostic Software)
Configuration interface	M8, 4-pin
Data interface	RS-422
Transmission rate	≤ 500 kBaud
Safe SICK device communication via EFI	
Transmission rate	≤ 500 kBaud
Cable length	≤ 50 m
Conductor cross-section	0.22 mm ²

¹⁾ Freely programmable, e.g., external device monitoring input, reset input, contamination warning, reset required.

²⁾ Availability depends on the configuration of the universal I/Os.

³⁾ 2+1; additional input is only available if reset and reset required are not being used.

⁴⁾ In combination with an EFI device (Flexi Soft or EFI gateway) five static control inputs are available. Otherwise three.

⁵⁾ Two of the static switching signals can be used either as dynamic or as static switching signals.

⁶⁾ Freely programmable, e.g. warning field, contamination, reset required.

Electrical data

Protection class	III (EN 50178, EN 60950)
Supply voltage V_s	24 V DC (16.8 V DC ... 30 V DC)
Power consumption	≤ 0.33 A ¹⁾ ≤ 1.7 A ²⁾
Outputs	
Safety outputs (OSSD)	2 x 250 mA
Diagnostic outputs	3 x 100 mA ³⁾

¹⁾ At 24 V DC without output load.

²⁾ At 24 V DC including maximum output load.

³⁾ Freely programmable, e.g. warning field, contamination, reset required.

Mechanical data

Dimensions (W x H x D)	102 mm x 152 mm x 106 mm
Weight	1.2 kg
Housing material	Aluminum die cast
Housing color	RAL 1021 (yellow)
Optics cover material	Polycarbonat
Optics cover surface finish	Outside with scratch-resistant coating

Ambient data

Enclosure rating	IP65 (EN 60529)
Ambient operating temperature	-10 °C ... +50 °C
Storage temperature	-25 °C ... +50 °C
Vibration resistance	5 g, 10 Hz ... 150 Hz (IEC 61496-1, IEC 61496-3)
Shock resistance	
Continuous shock	10 g, 16 ms (IEC 61496-1, IEC 61496-3)
Single shock	15 g, 11 ms (IEC 61496-1, IEC 61496-3)

Other information

Type of light	Pulsed laser diode
Wave length	905 nm
Detectable remission	1.8 % ... > 1,000 % (reflectors)
Laser class	1 (21 CFR 1040.10 and 1040.11, IEC 60825-1)

Flexi Classic

Safety-related parameters

Safety integrity level	SIL3 (IEC 61508) SILCL3 (EN 62061)
Category	Category 4 (EN ISO 13849)
Performance level	PL e (EN ISO 13849)
PFH_D (mean probability of a dangerous failure per hour)	2.5 x 10 ⁻⁹ (EN ISO 13849)
T_M (mission time)	20 years (EN ISO 13849)

Functions

Restart interlock	Manual / automatic (configurable)
External device monitoring (EDM)	✓
AND operation	✓
OR operation	✓
Bypass	✓
Differentiation between man and material (muting)	✓

Interfaces

Inputs	4 safety inputs 4 switching inputs
Number of muting sensors	0 / 2
Outputs	4 safety outputs 2 test outputs
Delay time (outputs Q3/Q4)	0 s ... 5 s
Connection type	Plug-in screw-type terminals
Permitted cross-section	
Single wire or fine wire (1x)	0.14 mm ² ... 2.5 mm ²
Single wire or fine wire (2x)	0.14 mm ² ... 0.75 mm ²
Finely stranded with ferrules (1x)	0.25 mm ² ... 2.5 mm ²
Finely stranded with ferrules (2x)	0.25 mm ² ... 0.5 mm ²
Display elements	LEDs
Fieldbus, industrial network	CANopen DeviceNet™ EtherNet/IP™ Modbus TCP PROFIBUS DP PROFINET
Type of fieldbus integration	Flexi Classic gateway

Electrical data

Protection class	III (EN 61140)
Type of voltage supply	PELV or SELV ¹⁾
Supply voltage V_s	24 V DC (19.2 V DC ... 30 V DC)
Residual ripple	≤ 10 %
Power consumption	≤ 3 W (DC)
Switch-on time	≤ 60 s

¹⁾ The current of the power supply that powers the main unit must be limited to a maximum of 4 A, either through the power supply itself or a fuse.

Mechanical data

Dimensions (W x H x D)	22.5 mm x 96.5 mm x 120.8 mm
Weight	180 g

Ambient data

Enclosure rating	Housing	IP40 (EN 60529)
	Terminals	IP20 (EN 60529)
Ambient operating temperature	-25 °C ... +55 °C	
Storage temperature	-25 °C ... +70 °C	
Air humidity	10 % ... 95 %, non-condensing	
Climate conditions according to	EN 61131-2 (55 °C ambient operating temperature, 95% rel. humidity)	
Vibration resistance	5 g RMS, 5 Hz ... 500 Hz (EN 60068-2-64)	

Ordering information

Items supplied Safe AGV Easy 3:

- Safe AGV Easy operating instructions for download → www.sick.com/Safe_AGV_Easy
- 2 x S300 Professional safety laser scanner
- 2 x S300 Professional system plug with cable, 10 m, 15-wire, flying leads
- 2 x S300 Professional operating instructions and CDS (Configuration & Diagnostic Software) on DVD
- 2 x S300 Professional adhesive label with information on the daily check
- Flexi Classic main module
- Flexi Classic screw terminal connector
- Flexi Classic operating instructions for download → www.sick.com/Flexi_Classic

Description	Type	Part no.
Safe AGV Easy 3	SAPP03D-08A0007	1084029

Dimensional drawings (Dimensions in mm (inch))

Laser scanner

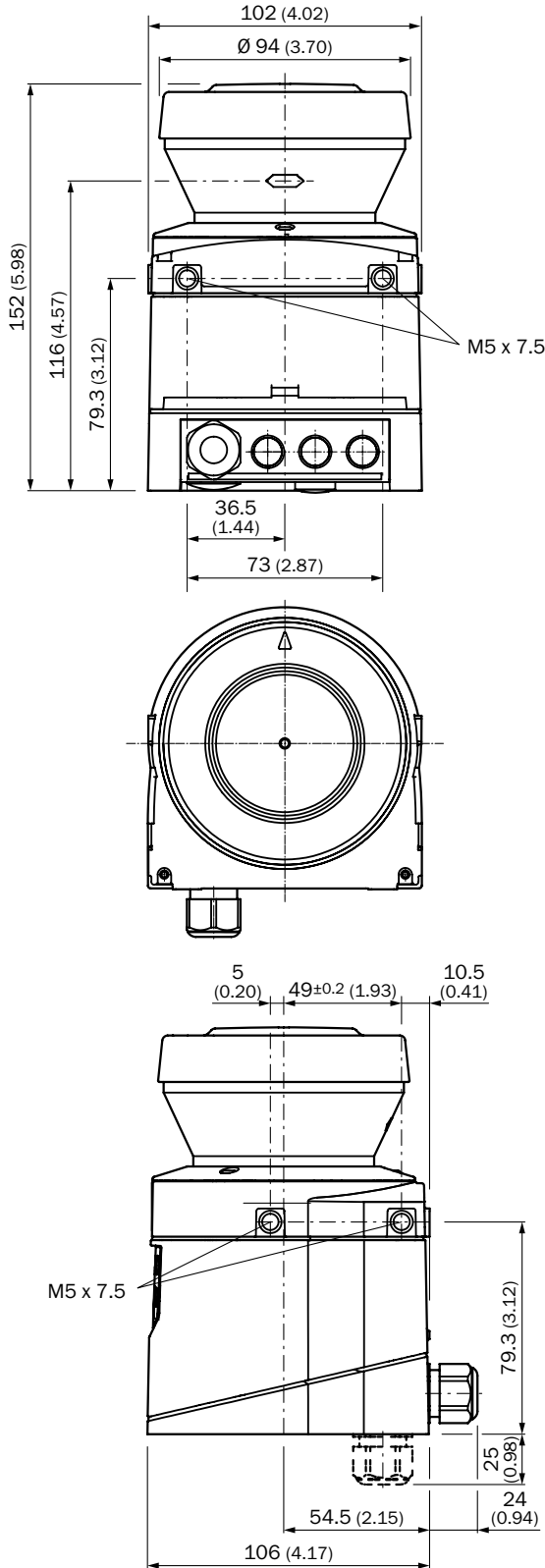

Flexi Classic main module

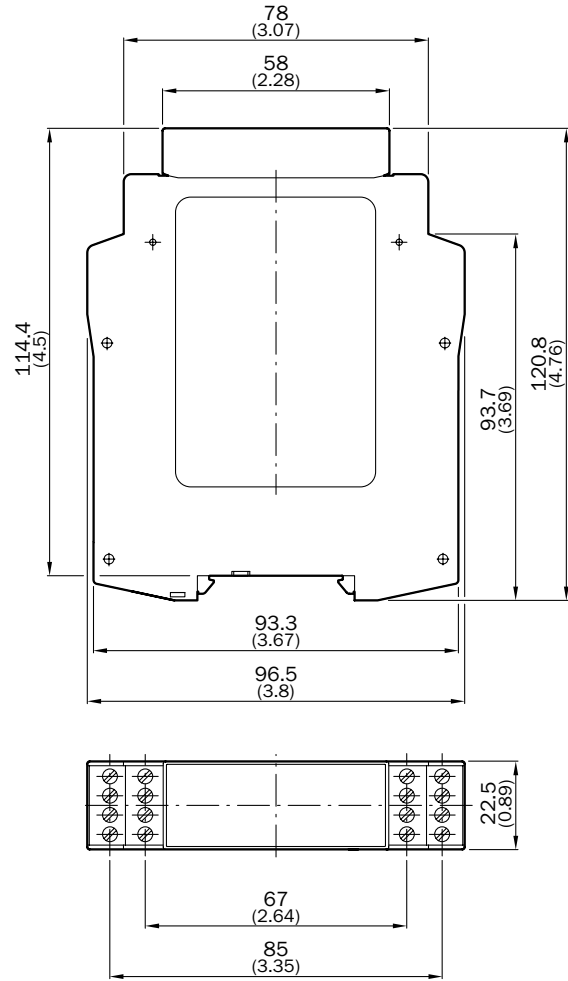

Accessories required for commissioning





Description	Number	Items supplied	Further information
Safe AGV Easy: Operating instructions	1	-	→ www.sick.com/Safe_AGV_Easy
S300 Professional: Mounting bracket	2	-	→ Mounting brackets and mounting plates
S300 Professional: System plug with connecting cable	2	✓	-
S300 Professional: EFI connecting cable	1	-	→ Plug connectors and cables
S300 Professional: Connection cable for configuration and diagnosis	1	-	→ Plug connectors and cables
S300 Professional: CDS (Configuration & Diagnostic Software)	2	✓	-
S300 Professional: Operating instructions	2	✓	-
Flexi Classic: Screw-terminal connector	1	✓	-
Flexi Classic: Operating instructions	1	-	→ www.sick.com/Flexi_Classic
UE48-30S (for switching current above 2 A and/or switching voltage above 24 V DC (up to 230 V AC))	0 / 1	-	→ Safety relays

Accessories

Mounting systems

Mounting brackets and mounting plates

Mounting brackets

Figure	Description	Packing unit	Type	Part no.
	Mounting bracket for rear mounting on wall or machine	1 piece	Mounting kit 1a	2034324
	Mounting bracket for rear mounting on wall or machine with protection of optics hood	1 piece	Mounting kit 1b	2034325
	Mounting bracket, adjustable lateral axis, only in conjunction with mounting kit 1a (2034324) or 1b (2034325)	1 piece	Mounting kit 2	2039302
	Mounting plate, adjustable longitudinal axis, only in conjunction with mounting kit 2 (2039302)	1 piece	Mounting kit 3	2039303

Dimensional drawings → [page 33](#)

Connection systems

Plug connectors and cables

Connection cables with male and male connector

- **Model:** PVC, unshielded

Figure	Connection type		Description	Conductor cross-section	Cable length	Type	Part no.
	Male connector, M8, 4-pin, straight	Male connector, USB-A, straight	For connecting the configuration connection to the USB interface on the PC	0.25 mm ²	2 m	DSL-8U04G02M025KM1	6034574
					10 m	DSL-8U04G10M025KM1	6034575

Cables (ready to assemble)

Figure	Description	Model	Conductor cross-section	Cable diameter	Number of cores	Items supplied	Type	Part no.
	Fitting for EFI connections	PVC, shielded	1 x 2 x 0.22 mm ²	Ø 5.7 mm	2-wire	by the meter	EFI connecting cable	6029448

Cable glands

Figure	Connection type	Description	Permitted cable diameter	Type	Part no.
	M12	For EFI connections and incremental encoders, for quick and easy shield connection, EMC proof	3 mm ... 6.5 mm	M12 gland	5314772

Power supply units and power cord connectors

Figure	Input voltage	Output voltage	Output current	Type	Part no.
 Illustration may differ	100 V AC ... 240 V AC	24 V DC	≤ 2.1 A	PS50WE24V	7028789
			≤ 3.9 A	PS95WE24V	7028790

Further accessories

Test and monitoring tools

Figure	Description	Type	Part no.
 Illustration may differ	Scan finder, receiver to localize infrared scans	Scan-Finder LS-80L	6020756

Spare parts

Figure	Description	Type	Part no.
	Spare part set optics cover with replacement seal and screws	Spare parts set optics cover S100/S300/S300 Mini	2039248

Safety relays

UE48-30S

Figure	Description	Number of enable current (N/O) contacts	Connection type	Type	Part no.
 Illustration may differ	Evaluation unit for safety sensors for switching current above 2 A and/or switching voltage above 24 V DC (up to 230 V AC)	3	Fixed screw terminals	UE48-30S2D2S1	1067636

Safety controllers

Flexi Classic

Figure	Module	Inputs	Outputs	Connection type	Type	Part no.
 Illustration may differ	Flexi Classic input extension	8 safety inputs	8 test outputs	Plug-in screw-type terminals	UE410-8DI3	6026139

Dimensional drawings for accessories (Dimensions in mm (inch))

Mounting brackets and mounting plates

Mounting kit 1a

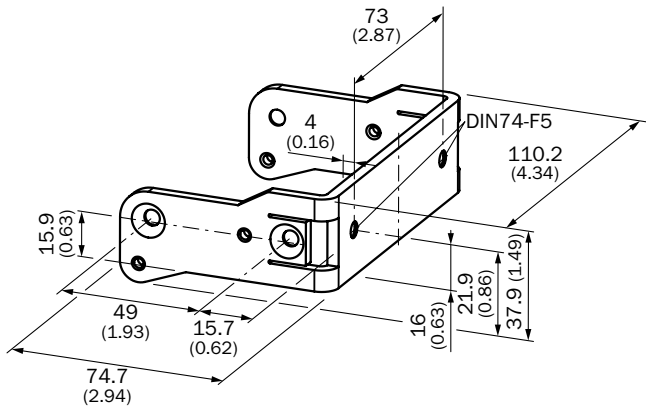

Mounting kit 1b

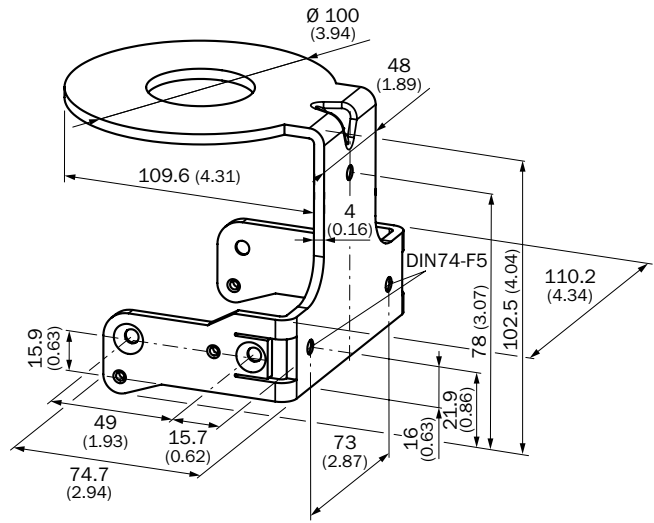

Mounting kit 2

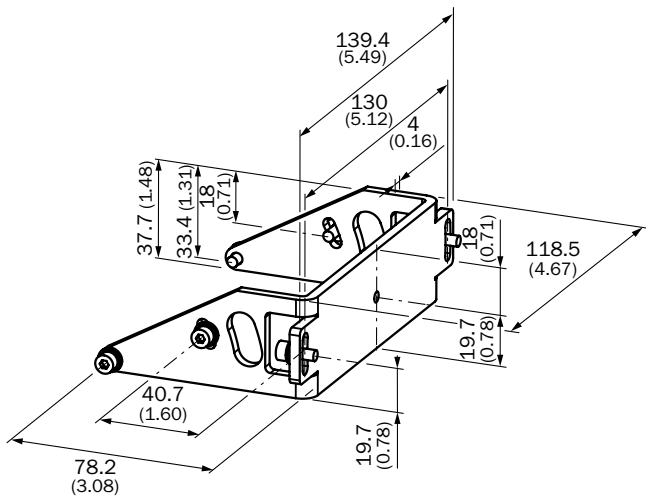

Mounting kit 3

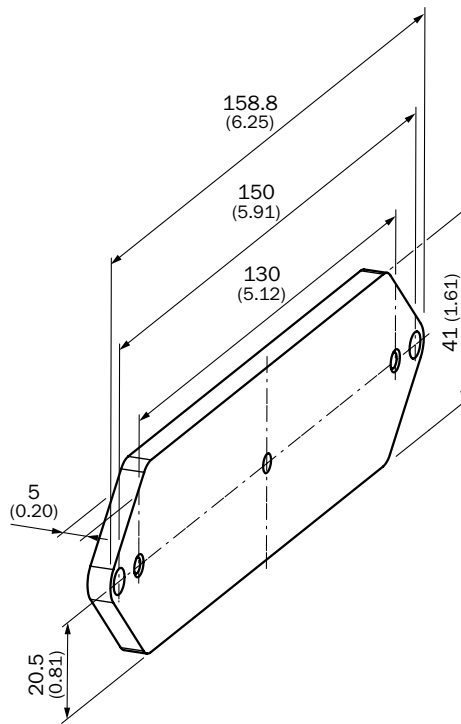

REGISTER AT WWW.SICK.COM TODAY AND ENJOY ALL THE BENEFITS

- ✓ Select products, accessories, documentation and software quickly and easily.
- ✓ Create, save and share personalized wish lists.
- ✓ View the net price and date of delivery for every product.
- ✓ Requests for quotation, ordering and delivery tracking made easy.
- ✓ Overview of all quotations and orders.
- ✓ Direct ordering: submit even very complex orders in moments.
- ✓ View the status of quotations and orders at any time. Receive e-mail notifications of status changes.
- ✓ Easily repeat previous orders.
- ✓ Conveniently export quotations and orders to work with your systems.

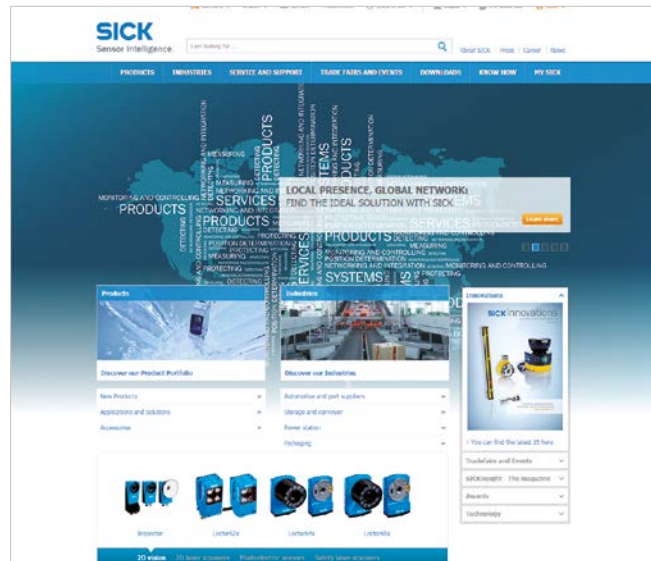

SERVICES FOR MACHINES AND SYSTEMS: SICK LifeTime Services

Our comprehensive and versatile LifeTime Services are the perfect addition to the comprehensive range of products from SICK. The services range from product-independent consulting to traditional product services.



Consulting and design
Safe and professional



Product and system support
Reliable, fast and on-site



Verification and optimization
Safe and regularly inspected



Upgrade and retrofits
Easy, safe and economical



Training and education
Practical, focused and professional

SICK AT A GLANCE

SICK is a leading manufacturer of intelligent sensors and sensor solutions for industrial applications. With more than 7,400 employees and over 50 subsidiaries and equity investments as well as numerous agencies worldwide, we are always close to our customers. A unique range of products and services creates the perfect basis for controlling processes securely and efficiently, protecting individuals from accidents and preventing damage to the environment.

We have extensive experience in various industries and understand their processes and requirements. With intelligent sensors, we can deliver exactly what our customers need. In application centers in Europe, Asia and North America, system solutions are tested and optimized in accordance with customer specifications. All this makes us a reliable supplier and development partner.

Comprehensive services round out our offering: SICK LifeTime Services provide support throughout the machine life cycle and ensure safety and productivity.

For us, that is “Sensor Intelligence.”

Worldwide presence:

Australia, Austria, Belgium, Brazil, Canada, Chile, China, Czech Republic, Denmark, Finland, France, Germany, Great Britain, Hungary, India, Israel, Italy, Japan, Malaysia, Mexico, Netherlands, New Zealand, Norway, Poland, Romania, Russia, Singapore, Slovakia, Slovenia, South Africa, South Korea, Spain, Sweden, Switzerland, Taiwan, Thailand, Turkey, United Arab Emirates, USA, Vietnam.

Detailed addresses and further locations → www.sick.com