

TiM8xxP

2D LiDAR sensors

SICK
Sensor Intelligence.



Product described

TiM8xxP

Manufacturer

SICK AG
Erwin-Sick-Str. 1
79183 Waldkirch
Germany

Legal information

This work is protected by copyright. Any rights derived from the copyright shall be reserved for SICK AG. Reproduction of this document or parts of this document is only permissible within the limits of the legal determination of Copyright Law. Any modification, abridgment or translation of this document is prohibited without the express written permission of SICK AG.

The trademarks stated in this document are the property of their respective owner.

© SICK AG. All rights reserved.

Original document

This document is an original document of SICK AG.



Contents

1	About this document.....	5
1.1	Information on the operating instructions.....	5
1.2	Explanation of symbols.....	5
2	Safety information.....	6
2.1	Intended use.....	6
2.2	Improper use.....	6
2.3	Cybersecurity.....	6
2.4	Limitation of liability.....	7
2.4.1	Programmable device.....	7
2.5	Modifications and conversions.....	7
2.6	Requirements for skilled persons and operating personnel.....	7
2.7	Operational safety and specific hazards.....	8
3	Product description.....	10
3.1	Scope of delivery.....	10
3.2	Setup and dimensions.....	11
3.3	Display and operating elements.....	12
3.4	Type code.....	12
3.5	Product identification.....	12
3.6	SICK AppSpace.....	13
3.7	Principle of operation.....	14
3.7.1	Measurement principle.....	14
3.7.2	Distance measurement.....	14
3.7.3	Direction measurement.....	14
3.7.4	Object sizes.....	15
3.7.5	Scan field flatness (conical error and tilt).....	16
3.7.6	Impact of object surfaces on the measurement.....	16
3.7.7	Scanning range.....	18
4	Transport and storage.....	20
4.1	Transport.....	20
4.2	Unpacking.....	20
4.3	Transport inspection.....	20
4.4	Storage.....	20
5	Mounting.....	21
5.1	Mounting instructions.....	21
5.2	Mounting device.....	21
5.3	Mutual interference.....	22
6	Electrical installation.....	23
6.1	Prerequisites for safe operation of the device.....	23
6.2	Electrical block diagram for commissioning.....	26
6.3	Wiring instructions.....	27

6.4	Connection diagram.....	27
6.4.1	TiMxxxP-21xxxx.....	27
6.4.2	USB interface.....	28
6.5	Connecting the device electrically.....	28
6.6	Wiring digital inputs / digital outputs.....	29
7	Commissioning.....	31
7.1	Programming the device using SICK AppStudio.....	31
8	Maintenance.....	32
8.1	Maintenance plan.....	32
8.2	Cleaning.....	32
9	Troubleshooting.....	33
9.1	Repairs.....	33
9.2	Returns.....	33
9.3	Disposal.....	33
10	Technical data.....	34
10.1	Features.....	34
10.2	Performance.....	35
10.3	Interfaces.....	35
10.4	Mechanics/electronics.....	36
10.5	Ambient data.....	36
11	Accessories.....	38
12	Annex.....	39
12.1	Declarations of conformity and certificates.....	39
12.2	Licenses.....	39

1 About this document

1.1 Information on the operating instructions

These operating instructions provide important information on how to use devices from SICK AG.

Prerequisites for safe work are:

- Compliance with all safety notes and handling instructions supplied.
- Compliance with local work safety regulations and general safety regulations for device applications

The operating instructions are intended to be used by qualified personnel and electrical specialists.



NOTE

Read these operating instructions carefully to familiarize yourself with the device and its functions before commencing any work.

The operating instructions are an integral part of the product. Store the instructions in the immediate vicinity of the device so they remain accessible to staff at all times. Should the device be passed on to a third party, these operating instructions should be handed over with it.

These operating instructions do not provide information on the handling and safe operation of the machine or system in which the device is integrated. Information on this can be found in the operating instructions for the machine or system.

1.2 Explanation of symbols

Warnings and important information in this document are labeled with symbols. Signal words introduce the instructions and indicate the extent of the hazard. To avoid accidents, damage, and personal injury, always comply with the instructions and act carefully.



DANGER

... indicates a situation of imminent danger, which will lead to a fatality or serious injuries if not prevented.



WARNING

... indicates a potentially dangerous situation, which may lead to a fatality or serious injuries if not prevented.



CAUTION

... indicates a potentially dangerous situation, which may lead to minor/slight injuries if not prevented.



NOTICE

... indicates a potentially harmful situation, which may lead to material damage if not prevented.



NOTE

... highlights useful tips and recommendations as well as information for efficient and trouble-free operation.

2 Safety information

2.1 Intended use

The TiM8xxP is a programmable 2D LiDAR sensor. It features one scan plane and is suitable for applications which demand precise, non-contact optical contour measurement and environment perception.

The device is programmed on a computer by using the **SICK AppSpace** development environment software and the **SICK AppStudio** software program.

Depending on the application, a browser-based, graphical user interface (HMI) can be created, which provides opportunities defined by the application developer to influence an application at operator level.

The device offers various interfaces and operating elements for controlling, programming, and operating purposes, which can be activated as necessary via development environments, control systems (programmable logic controllers), or applications. However, configuration, programming, and control requires various technical skills, depending on how the device is connected and used.

The devices are primarily designed for use in industrial and logistics areas, and they meet the requirements for industrial ruggedness, interfaces and data processing.

SICK AG assumes no liability for losses or damage arising from the use of the product, either directly or indirectly. This applies in particular to use of the product that does not conform to its intended purpose.

2.2 Improper use

Any use outside of the stated areas, in particular use outside of the technical specifications and the requirements for intended use, will be deemed to be incorrect use.

- The device does not constitute a safety component in accordance with the respective applicable safety standards for machines.
- The device must not be used in explosion-hazardous areas, in corrosive environments or under extreme environmental conditions.
- Any use of accessories not specifically approved by SICK AG is at your own risk.



WARNING

Danger due to improper use!

Any improper use can result in dangerous situations.

Therefore, observe the following information:

- Product should be used only in accordance with its intended use.
 - All information in the documentation must be strictly observed.
 - Shut down the product immediately in case of damage.
-

2.3 Cybersecurity

Overview

To protect against cybersecurity threats, it is necessary to continuously monitor and maintain a comprehensive cybersecurity concept. A suitable concept consists of organizational, technical, procedural, electronic, and physical levels of defense and considers suitable measures for different types of risks. The measures implemented in this product can only support protection against cybersecurity threats if the product is used as part of such a concept.

You will find further information at www.sick.com/psirt, e.g.:

- General information on cybersecurity
- Contact option for reporting vulnerabilities
- Information on known vulnerabilities (security advisories)

2.4 Limitation of liability

Relevant standards and regulations, the latest technological developments, and our many years of knowledge and experience have all been taken into account when compiling the data and information contained in these operating instructions. The manufacturer accepts no liability for damage caused by:

- Non-adherence to the product documentation (e.g., operating instructions)
- Incorrect use
- Use of untrained staff
- Unauthorized conversions or repair
- Technical modifications
- Use of unauthorized spare parts, consumables, and accessories

2.4.1 Programmable device

The product is a programmable device.

The respective programmer is therefore responsible for his/her programming work and the resultant operation of the product.

The liability and warranty of SICK AG is limited to the device specification (hardware functionality and any application programming interfaces) according to the agreed conditions.

Therefore, SICK AG is not liable, among other things, for damages that are caused by programming of the customer or third parties.

2.5 Modifications and conversions



NOTICE

Modifications and conversions to the device may result in unforeseeable dangers.

Interrupting or modifying the device or SICK software will invalidate any warranty claims against SICK AG. This applies in particular to opening the housing, even as part of mounting and electrical installation.

2.6 Requirements for skilled persons and operating personnel



WARNING

Risk of injury due to insufficient training.

Improper handling of the device may result in considerable personal injury and material damage.

- All work must only ever be carried out by the stipulated persons.

The following qualifications are required for various activities:

Table 1: Activities and technical requirements

Activities	Qualification
Mounting, maintenance	<ul style="list-style-type: none"> ■ Basic practical technical training ■ Knowledge of the current safety regulations in the workplace

Activities	Qualification
Electrical installation, device replacement	<ul style="list-style-type: none"> ■ Practical electrical training ■ Knowledge of current electrical safety regulations ■ Knowledge of the operation and control of the devices in their particular application
Commissioning, configuration, programming	<ul style="list-style-type: none"> ■ Basic knowledge of the computer operating system used ■ Basic knowledge of the design and setup of the described connections and interfaces ■ Basic knowledge of data transmission ■ Knowledge of the programming of systems and network components
Operation of the device for the particular application	<ul style="list-style-type: none"> ■ Knowledge of the operation and control of the devices in their particular application ■ Knowledge of the software and hardware environment for the particular application

2.7 Operational safety and specific hazards

Please observe the safety notes and the warnings listed here and in other sections of this product documentation to reduce the possibility of risks to health and avoid dangerous situations.



CAUTION

Optical radiation: Class 1 Laser Product

The accessible radiation does not pose a danger when viewed directly for up to 100 seconds. It may pose a danger to the eyes and skin in the event of incorrect use.

- Do not open the housing. Opening the housing may increase the level of risk.
- Current national regulations regarding laser protection must be observed.

Caution – Use of controls or adjustments or performance of procedures other than those specified herein may result in hazardous radiation exposure.

It is not possible to entirely rule out temporary disorienting optical effects, particularly in conditions of dim lighting. Disorienting optical effects may come in the form of dazzle, flash blindness, afterimages, photosensitive epilepsy, or impairment of color vision, for example.



WARNING

Electrical voltage!

Electrical voltage can cause severe injury or death.

- Work on electrical systems must only be performed by qualified electricians.
- The power supply must be disconnected when attaching and detaching electrical connections.
- The product must only be connected to a voltage supply as set out in the requirements in the operating instructions.
- National and regional regulations must be complied with.
- Safety requirements relating to work on electrical systems must be complied with.

**WARNING****Risk of injury and damage caused by potential equalization currents!**

Improper grounding can lead to dangerous equipotential bonding currents, which may in turn lead to dangerous voltages on metallic surfaces, such as the housing. Electrical voltage can cause severe injury or death.

- Work on electrical systems must only be performed by qualified electricians.
 - Follow the notes in the operating instructions.
 - Install the grounding for the product and the system in accordance with national and regional regulations.
-

3 Product description

3.1 Scope of delivery

The delivery of the device includes the following components:

Table 2: Scope of delivery

No. of units	Component	Notes
1	Device in the version ordered 2x fastening clips, 2x M3 x 5 mm screws	Without connecting cables
1	Printed safety notes, multilingual	Quick guide and general safety notes

- ⑪ Marking for the position of the light emission level
- ⑫ Ethernet connection, 4-pin M12 female connector
- ⑬ Area in which no reflective surfaces are permitted when the device is mounted
- ⑭ Bearing marking to support alignment (90° axis)
- ⑮ 270° aperture angle (field of vision)
- ⑯ 2 x countersunk screw (Torx TX 6) M2 x 4 mm

3.3 Display and operating elements

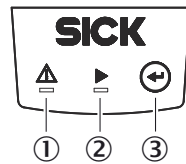

Figure 2: TiM8xxP display and operating elements

- ① Red LED
- ② Green LED
- ③ Pushbutton

Status indicators

The LEDs can display the off, flashing or permanently illuminated status depending on the programming of the device. Which functions are triggered when the pushbutton is actuated can also be programmed.

3.4 Type code

The devices of the product family are arranged according to the following type code:

TIM	x	y	z		-	aa	bb	c	dd
1	2	3	4	5		6	7	8	9

Table 3: Type code

Position	Description	Characteristic
1	Device name	TIM: Short range 2D-LiDAR sensor
2	Device type	8. AppSpace device
3	Performed by	8: 25 m measuring range, 0.33° angular resolution, performance professional, HDDM+
4	Housing	1: Housing IP67 without heating
5		P: Programmable
6	Connection	21: Rotating connection unit, 1 x M12 male connector, 12-pin, D-coded (Power + I/O); 1x M12 female connector, 4-pin, A-coded (Ethernet)
7	Application	00: AppSpace standard
8	Laser type	1: Pulse power up to 880 mW, pulse width up to 5 ns, pulse rate 1,500 kHz
9	Color	01: Gray

3.5 Product identification

The type label gives information for identification of the product variant.

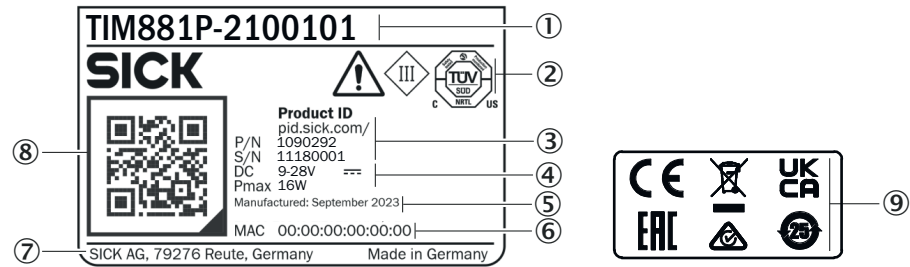

- ① Type code
- ② Conformity mark/certification mark, symbol: Observe the operating instructions!
- ③ Product ID with part number (P/N) and serial number (S/N)
- ④ Voltage supply, maximum power consumption
- ⑤ Production date
- ⑥ MAC address
- ⑦ Manufacturer/production location
- ⑧ QR code with product data (part number, serial number), example: pid.sick.com/1090608/23000000
- ⑨ Conformity mark/certification mark

3.6 SICK AppSpace



The SICK AppSpace eco-system reveals new paths leading to solutions for customer-specific applications and consists of software tools and programmable sensors or devices. The SICK AppStudio SDK is used for developing sensor apps on programmable SICK devices. Its user interface for machine operators can be created individually as a web GUI. The SICK AppManager software tool supports the service in the field in the simple distribution and management of sensor apps.

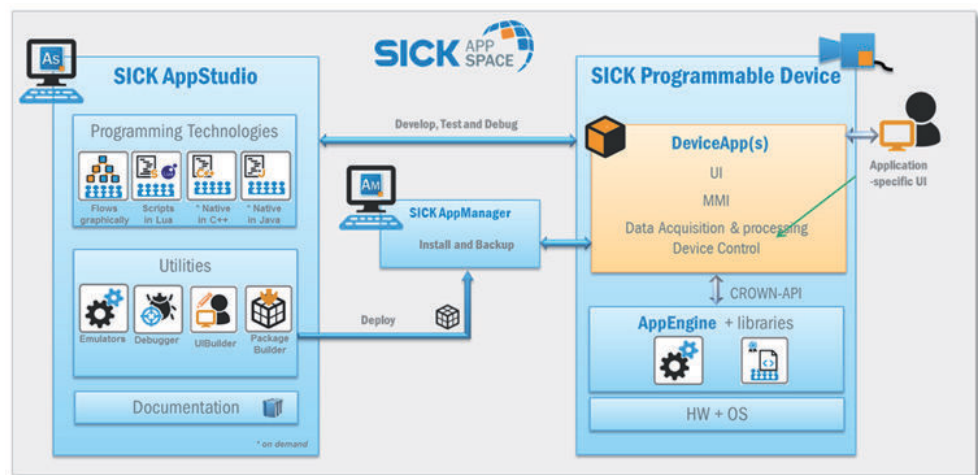

Figure 3: SICK AppSpace

Detailed instructions on the SICK AppStudio as well as programming the device can be found at supportportal.sick.com.

3.7 Principle of operation

3.7.1 Measurement principle

The device is an opto-electronic LiDAR sensor (laser scanner) that uses laser beams for non-contact scanning of the outline of its surroundings on a plane. The device measures its surroundings in two-dimensional polar coordinates, relative to its measurement origin. This is marked by a circular indentation in the center of the optics cover. If a laser beam strikes an object, the position of that object is determined in terms of distance and direction.

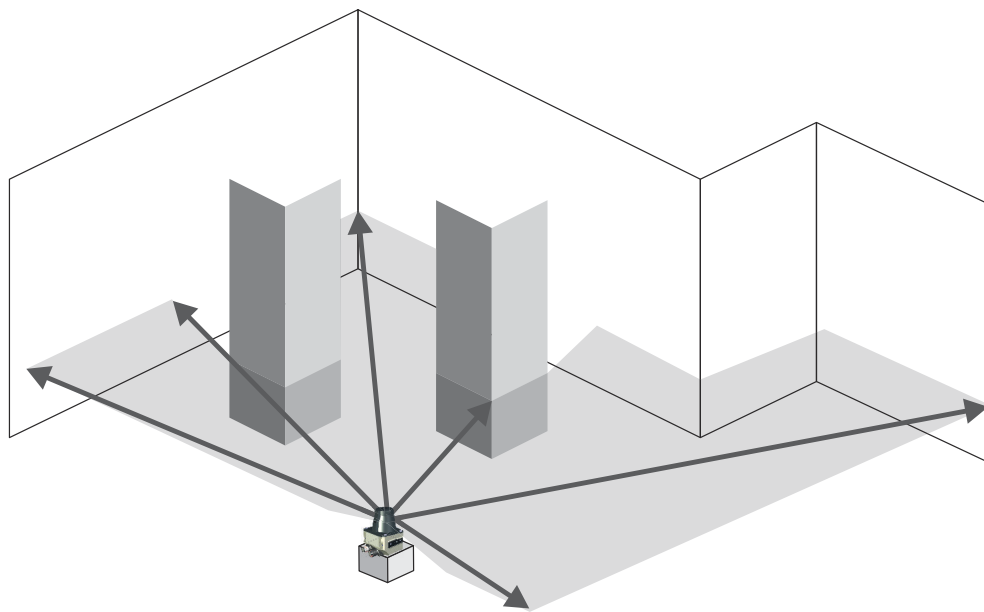

Figure 4: The 2D LiDAR sensor measurement principle

3.7.2 Distance measurement

The device emits beams pulsed by a laser diode. If a laser pulse hits an object or person, it is reflected on the surface of the object or person in question. The reflection is registered by a photosensitive element in the device receiver. The device uses SICK's own HDDM+ (High Definition Distance Measurement) technology. With this measurement process, a measured value is formed by adding together multiple single pulses. The device calculates the distance from the object based on the elapsed time that the light requires between emitting the beam and receiving the reflection. Radar systems apply this "pulse time-of-flight measurement" principle in a similar way.

3.7.3 Direction measurement

The device uses a rotating mirror to deflect the emitted laser beams, thereby scanning its surroundings in a circular pattern. The measurements are triggered internally by an encoder in regular angle increments.

The measuring procedure uses the averaging from multiple pulses to determine individual measured values. A measuring point is the average value of several measurements combined.

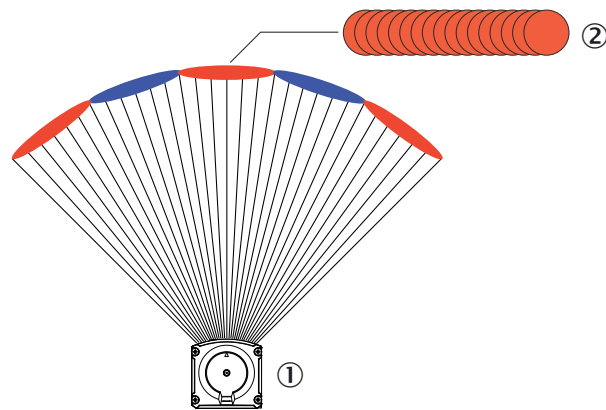

- ① Device
- ② Laser pulse

3.7.4 Object sizes

As the distance from the device increases, the laser beam expands. As a result, the diameter of the light spot on the surface of the object increases.



Figure 5: Beam expansion

- ① Expanded laser beam
- ② Optical axis

Required values for calculating the light spot size and minimum object size:

- Light spot size on the device cover: 7 mm (rounded up)
- Light spot divergence per single pulse: 0.49 deg (8.6 mrad)
- HDDM+ supplement (1 measured value consists of several overlapping single pulses): 5.8 mrad

Formula for calculating the light spot width:

(Light spot divergence [mrad] + supplement [mrad]) * distance [mm] + light spot size on the device cover [mm] = light spot width [mm]

Calculation example of light spot width at a distance of 4 m, with supplement 5.8 mrad:

$$(8.6 \text{ mrad} + 5.8 \text{ mrad}) * 4,000 \text{ mm} + 7 \text{ mm} = 64.6 \text{ mm}$$

Formula for calculating the height of the light spot:

Light spot divergence [mrad] * Distance [mm] + Light spot size at the device cover [mm] = Light spot width [mm]

Example calculation of the light spot height at a distance of 4 m:

$$8.6 \text{ mrad} * 4,000 \text{ mm} + 7 \text{ mm} = 41.4 \text{ mm}$$

Formula for calculating the minimum object size:

2 * supplement [mrad] * distance [mm] + light spot height [mm] = minimum object size [mm]

Calculation example of minimum object size at a distance of 4 m, with supplement 5.8 mrad:

$$2 * 5.8 \text{ mrad} * 4,000 \text{ mm} + 41.4 \text{ mm} = 87.8 \text{ mm}$$



NOTE

For reliable measurement, in particular when using the device to output measured values, the laser needs to hit the object several times. Therefore, the object either needs to be larger than the minimum object size, or both the LiDAR sensor and the object must not be moving.

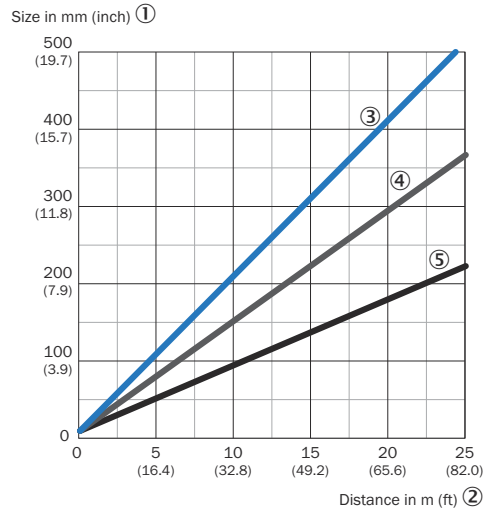

Figure 6: Minimum object size

- ① Size in millimeters (inc)
- ② Distance in meters (feet)
- ③ Minimum object size
- ④ Light spot width
- ⑤ Light spot height

3.7.5 Scan field flatness (conical error and tilt)

The scan field flatness describes the production-related vertical deviation of the horizontal scan plane of the sensor. Conical errors and tilt can affect the three-dimensional measurements. This should be taken into consideration to ensure reliable measurement results. Conical errors can only be corrected for a small viewing range. Tilt errors can be compensated for in many cases by mounting the sensor at a compensating angle. An alignment aid (e.g. item no.: 2086761) can help to position the sensor precisely and avoid alignment errors.

3.7.6 Impact of object surfaces on the measurement

Remission value

Remission is the ability of a material to reflect light. The remission correlates with the amount of laser light emitted by the LiDAR sensor which is reflected by an object (see Lambert's law).

Glossy surfaces have different remissions at the same distance with different angles of impact. In the case of shiny surfaces, maximum remission is achieved when the beam makes vertical impact.

Matt and dull surfaces have diffuse remission. They therefore exhibit similar relative remissions with the same angle of impact regardless of the distance from the zero point.

Table 4: Typical remissions of frequently used materials

Material	Typ. relative remission
Rubber tires (vulcanized, black)	2%
Foam rubber (black)	2.4%
Photographic board (black, matte)	10%
Cardboard (gray)	20%
Wood (untreated fir, soiled)	40%
PVC (gray)	50%
Paper (white, matte)	80%
Plaster (white)	100%
Aluminum (black anodized)	110 ... 150%
Steel (stainless, shiny)	120 ... 150%
Steel (high gloss)	140 ... 200%

Reflection

Most surfaces produce a diffuse reflection of the laser beam in all directions. The structure (smooth or rough), shape (flat or curved), and color (light or dark) of the surface determine how well the laser beam is reflected.

On very rough surfaces, a large proportion of the energy is lost due to absorption. Curved surfaces produce a higher diffusion. Dark surfaces reflect the laser beam worse than light ones (brilliant white plaster reflects approx. 100% of the light, while black foam rubber reflects approx. 2.4%). The aforementioned surface characteristics can reduce the scanning range of the device, in particular for surfaces with low remission values.

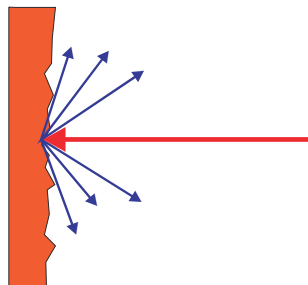

Figure 7: Reflection of light on the surface of the object

Angle of reflection

The angle of reflection corresponds to the angle of incidence. If the laser beam hits a surface at right angles, the energy is optimally reflected. If the laser beam hits a surface at an oblique angle, energy and range are lost accordingly.

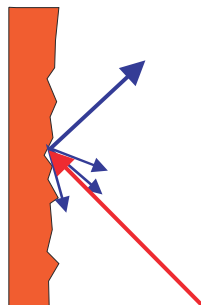

Figure 8: Angle of reflection

Retroreflection

If the reflective energy is greater than 100%, the beam is not reflected diffusely in all directions; instead it is reflected in a targeted way (retroreflection). Thus a large part of the emitted energy can be received by the laser distance measurer. Plastic reflectors (cat's eyes), reflective tape, and triple prisms have these properties.

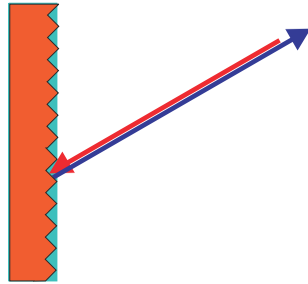

Figure 9: Retroreflection

Reflective surfaces

The laser beam is almost completely deflected on reflective surfaces. This means that an object hit by the deflected beam may be detected instead of the reflective surface.

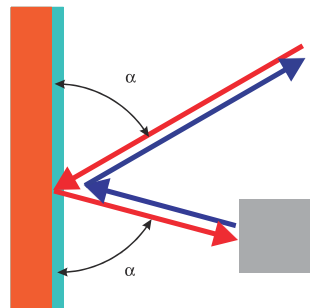

Figure 10: Specular surfaces

Small objects

Objects that are smaller than the diameter of the laser beam cannot reflect the laser light's full energy. The portion of the light beam that does not reach the object is lost. If all of the light reflected to the sensor is insufficient, the object may not be detected.

The portion of the light that does not reach the front object can be reflected by a larger object in the background. If all of the light reflected to the sensor is sufficient, this object is detected. This can lead to a corruption of the measured value.

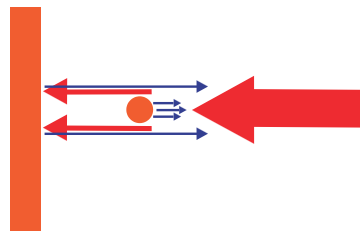

Figure 11: Object smaller than the laser beam diameter

3.7.7 Scanning range

The scanning range of the device depends on the remission of the object to be detected. The better a surface reflects the incident beam back to the device, the greater the scanning range of the device.

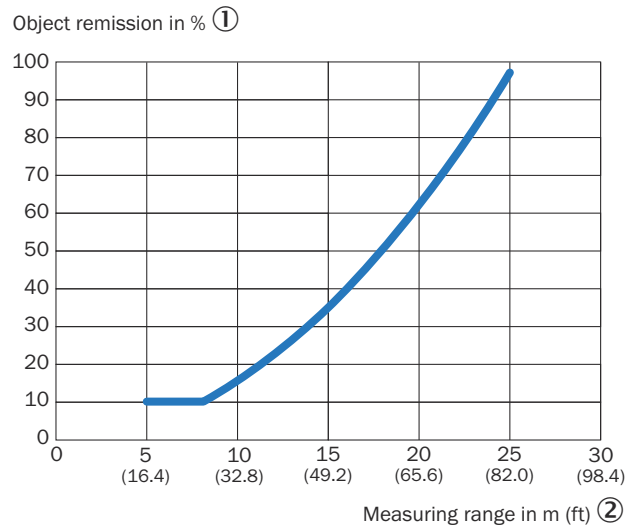

Figure 12: Scanning range rate as a function of object remission

- ① Object remission in percent
- ② Measuring range in meters (feet)

4 Transport and storage

4.1 Transport



NOTICE

Damage due to improper transport!

- The product must be packaged with protection against shock and damp.
 - Recommendation: Use the original packaging.
 - Note the symbols on the packaging.
 - Do not remove packaging until immediately before you start mounting.
-

4.2 Unpacking

- To protect the device against condensation, allow it to equilibrate with the ambient temperature before unpacking if necessary.
- Handle the device with care and protect it from mechanical damage.
- To avoid ingress of dust and water, only remove the protective elements, e.g. protective caps of the electrical connections just before attaching the connecting cable.

4.3 Transport inspection

Immediately upon receipt in Goods-in, check the delivery for completeness and for any damage that may have occurred in transit. In the case of transit damage that is visible externally, proceed as follows:

- Do not accept the delivery or only do so conditionally.
 - Note the scope of damage on the transport documents or on the transport company's delivery note.
 - File a complaint.
-



NOTE

Complaints regarding defects should be filed as soon as these are detected. Damage claims are only valid before the applicable complaint deadlines.

4.4 Storage

- Electrical connections are provided with a protective cap.
- Do not store outdoors.
- Store in a place protected from moisture and dust.
- Recommendation: Use the original packaging.
- To allow any residual dampness to evaporate, do not package in airtight containers.
- Do not expose to any aggressive substances.
- Protect from sunlight.
- Avoid mechanical shocks.
- Storage temperature: [see "Technical data", page 34](#).
- Relative humidity: [see "Technical data", page 34](#).
- For storage periods of longer than 3 months, check the general condition of all components and packaging on a regular basis.

5 Mounting

5.1 Mounting instructions

- Observe the technical data.
- Protect the sensor from direct and indirect sunlight.
- To prevent condensation, avoid exposing the device to rapid changes in temperature.
- The mounting site has to be designed for the weight of the device.
- The device can be mounted in any position.
- It should be mounted so that it is exposed to as little shock and vibration as possible. Optional mounting accessories are available, [see "Accessories", page 38](#).
- In application areas with severe vibrations or shocks caused by vibrations, jolts or abrupt changes in directions (e.g., when mounted to a manned forklift truck), mounting with vibration dampers is to be carried out ([see "Accessories", page 38](#)). Mount the device in a freely suspended manner.
- When mounting the device, make sure there are no reflective surfaces behind the reference target, [see "Setup and dimensions", page 11](#).
- When mounting the device, make sure the swivel connector area is recessed so it does not lie on the mounting surface [see "Setup and dimensions", page 11](#).
- To avoid inaccurate measurements when installing multiple devices: Make sure that the laser spot of one device is not in the visible range of another device, [see "Mutual interference", page 22](#).
- Avoid having shiny or reflective surfaces in the scanning range, e.g., stainless steel, aluminum, glass, reflectors, or surfaces with these types of coatings.
- Protect the device from moisture, contamination, and damage.
- Make sure that the status indicator is clearly visible.
- Do not subject the device to excessive shock or vibrations. In systems subjected to heavy vibrations, secure the fixing screws with screw-locking devices.
- The M3 x 5 screws included with delivery are intended for mounting the fastening clips via the blind hole threads on the rear or underside of the device, [see "Setup and dimensions", page 11](#). If the mounting clamps are not used or if other screws are used, the screws must not be screwed into the thread by more than 2.8 mm. The maximum tightening torque is 0.8 Nm.

5.2 Mounting device

1. Mount the LiDAR sensor using the designated fixing holes, [see "Setup and dimensions", page 11](#).



NOTICE **Risk of damage to the device**

the device will be damaged if the tightening torque of the mounting screws is too high or if the maximum screw-in depth of the blind hole threads is exceeded.

- ▶ Observe maximum tightening torque.
- ▶ Use suitable mounting screws for the blind hole threads of the device. Observe the maximum screw-in depth.

2. Make the electrical connection. Attach and tighten a voltage-free cable, [see "Connecting the device electrically", page 28](#).
3. Switch on the supply voltage.
4. Align the vertical center line of the field of view of the device with the center of the area to be monitored. The marking (90° axis) on the upper side of the optics cover serves as an alignment aid.

5.3 Mutual interference

**NOTE**

Optical sensors and other IR light sources can influence the measurement and detection capabilities of the device.

The device has been designed to minimize the probability of mutual interference with devices of the same type. To rule out even the slightest effects on the measurement accuracy, the devices should be arranged such the laser beams are not received by another device.

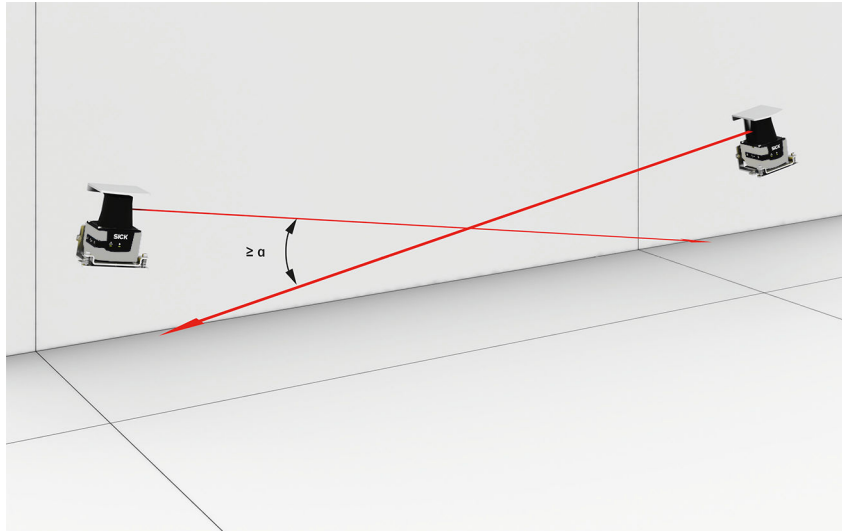

Figure 13: Angle $\geq 6^\circ$

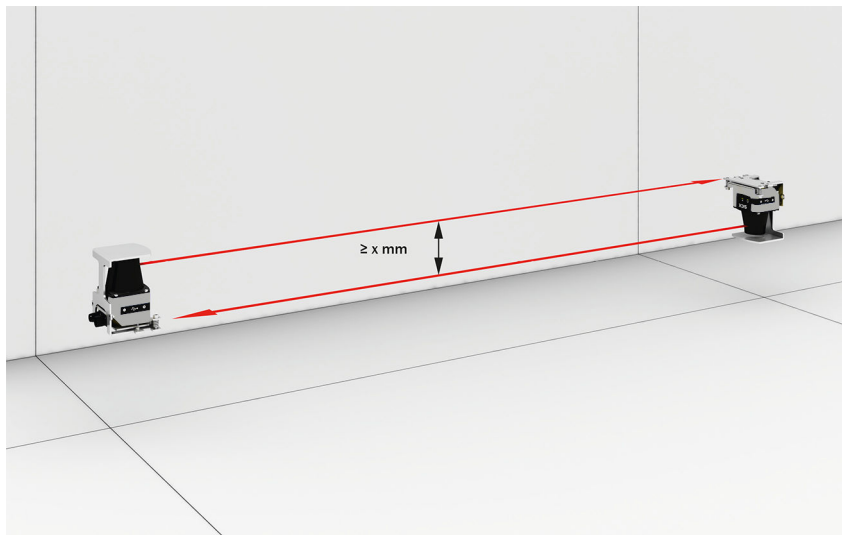

Figure 14: Distance ≥ 200 mm

6 Electrical installation

6.1 Prerequisites for safe operation of the device



WARNING

Risk of injury and damage caused by electrical current!

As a result of equipotential bonding currents between the device and other grounded devices in the system, faulty grounding of the device can give rise to the following dangers and faults:

- Dangerous voltages are applied to the metal housings.
- Devices will behave incorrectly or be destroyed.
- Cable shielding will be damaged by overheating and cause cable fires.

Remedial measures

- Only skilled electricians should be permitted to carry out work on the electrical system.
- If the cable insulation is damaged, disconnect the voltage supply immediately and have the damage repaired.
- Ensure that the ground potential is the same at all grounding points.
- Where local conditions do not meet the requirements for a safe earthing method, take appropriate measures. For example, ensure low-impedance and current-carrying equipotential bonding.

The device is connected to the peripheral devices (any local trigger sensor(s), system controller) via shielded cables. The cable shield – for the data cable, for example – rests against the metal housing of the device.

The device can be grounded through the cable shield or through a blind tapped hole in the housing, for example.

If the peripheral devices have metal housings and the cable shields are also in contact with their housings, it is assumed that all devices involved in the installation have the **same ground potential**.

This is achieved by complying with the following conditions:

- Mounting the devices on conductive metal surfaces
- Correctly grounding the devices and metal surfaces in the system
- If necessary: low-impedance and current-carrying equipotential bonding between areas with different ground potentials

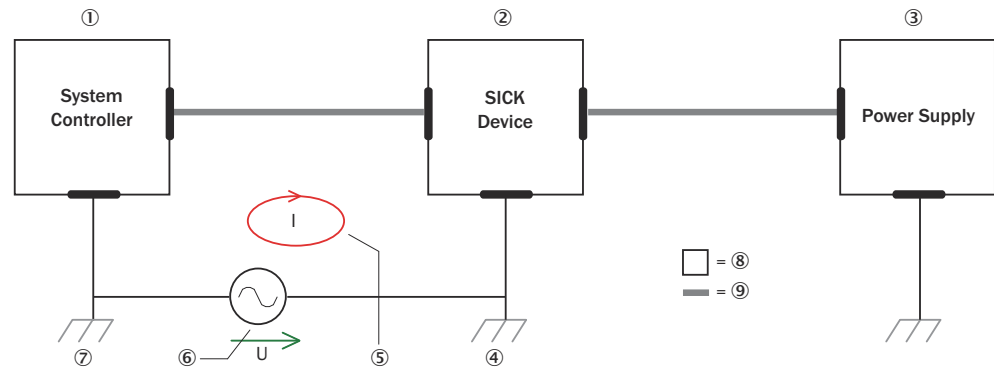

Figure 15: Example: Occurrence of equipotential bonding currents in the system configuration

- ① System controller
- ② Device
- ③ Voltage supply
- ④ Grounding point 2
- ⑤ Closed current loop with equalizing currents via cable shield
- ⑥ Ground potential difference
- ⑦ Grounding point 1
- ⑧ Metal housing
- ⑨ Shielded electrical cable

If these conditions are not fulfilled, equipotential bonding currents can flow along the cable shielding between the devices due to differing ground potentials and cause the hazards specified. This is, for example, possible in cases where there are devices within a widely distributed system covering several buildings.

Remedial measures

The most common solution to prevent equipotential bonding currents on cable shields is to ensure low-impedance and current-carrying equipotential bonding. If this equipotential bonding is not possible, the following solution approaches serve as a suggestion.



NOTICE

We expressly advise against opening up the cable shields. This would mean that the EMC limit values can no longer be complied with and that the safe operation of the device data interfaces can no longer be guaranteed.

Measures for widely distributed system installations

On widely distributed system installations with correspondingly large potential differences, the setting up of local islands and connecting them using commercially available **electro-optical signal isolators** is recommended. This measure achieves a high degree of resistance to electromagnetic interference.

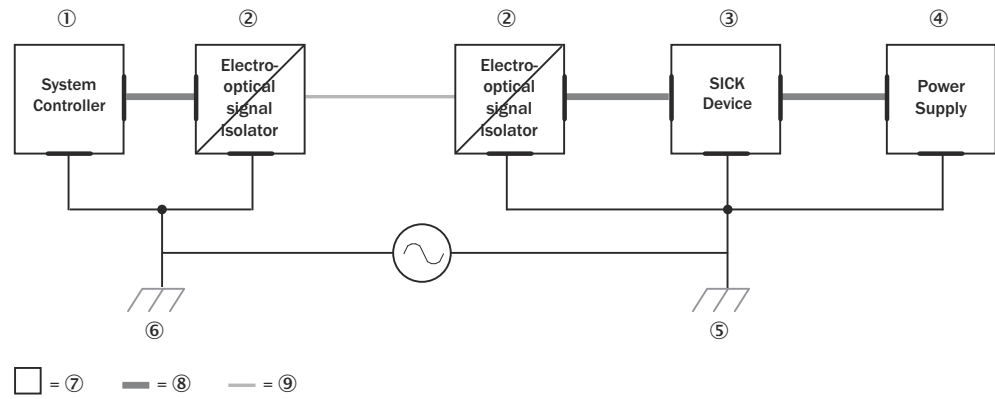

Figure 16: Example: Prevention of equipotential bonding currents in the system configuration by the use of electro-optical signal isolators

- ① System controller
- ② Electro-optical signal isolator
- ③ Device
- ④ Voltage supply
- ⑤ Grounding point 2
- ⑥ Grounding point 1
- ⑦ Metal housing
- ⑧ Shielded electrical cable
- ⑨ Optical fiber

The use of electro-optical signal isolators between the islands isolates the ground loop. Within the islands, a stable equipotential bonding prevents equalizing currents on the cable shields.

Measures for small system installations

For smaller installations with only slight potential differences, insulated mounting of the device and peripheral devices may be an adequate solution.

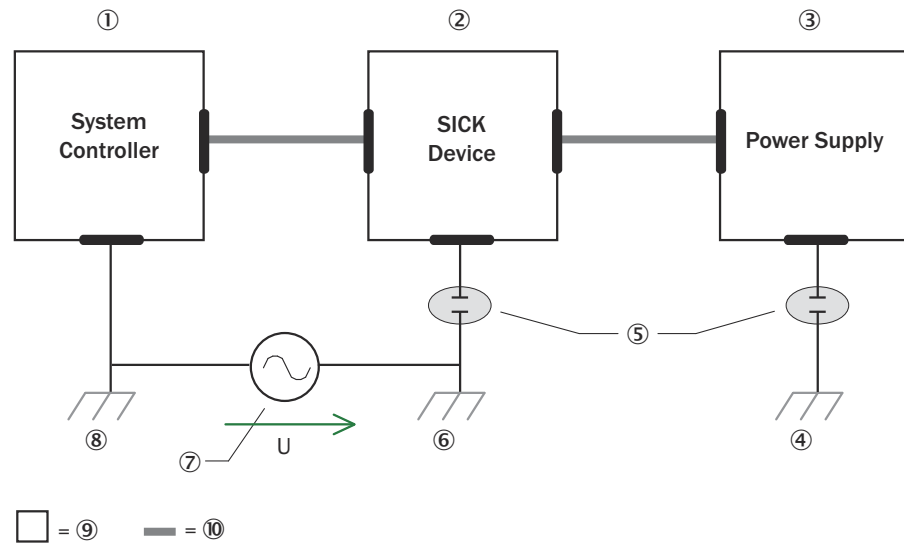

Figure 17: Example: Prevention of equipotential bonding currents in the system configuration by the insulated mounting of the device

- ① System controller
- ② Device
- ③ Voltage supply
- ④ Grounding point 3
- ⑤ Insulated mounting
- ⑥ Grounding point 2
- ⑦ Ground potential difference
- ⑧ Grounding point 1
- ⑨ Metal housing
- ⑩ Shielded electrical cable

Even in the event of large differences in the ground potential, ground loops are effectively prevented. As a result, equalizing currents can no longer flow via the cable shields and metal housing.



NOTICE

The voltage supply for the device and the connected peripheral devices must also guarantee the required level of insulation. Under certain circumstances, a tangible potential can develop between the insulated metal housings and the local ground potential.

6.2 Electrical block diagram for commissioning

TiMxxxP-21xxxx

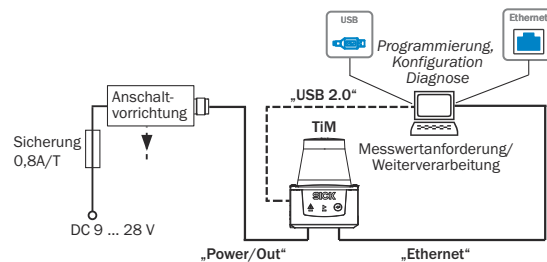

Figure 18: “Power, I/O” connection: With M12 male connector, 12-pin, A-coded; “Ethernet” connection: M12 female connector, 4-pin, D-coded

6.3 Wiring instructions



NOTE

Pre-assembled cables can be found on the product page.

The product page can be accessed via the **SICK Product ID: pid.sick.com/{P/N}/{S/N}**

{P/N} corresponds to the part number of the product, see type label.

{S/N} corresponds to the serial number of the product, see type label (if indicated).



NOTICE

Faults during operation and defects in the device or the system

Incorrect wiring may result in operational faults and defects.

- Follow the wiring notes precisely.

All electrical connections of the device are configured as M12 round connectors.

The enclosure rating stated in the technical data is achieved only with screwed plug connectors or protective caps.

Protect the device from dust and moisture when the plastic USB cover is open.

The USB interface is only for parameterization. Remove the USB cable for problem-free operation of the device.

All circuits connected to the device must be configured as SELV or PELV circuits. SELV = safety extra-low voltage, PELV = protective extra-low voltage.

Protect the device with an external 0.8 A slow-blow fuse at the beginning of the supply cable.

Connect the connecting cables in a de-energized state. Do not switch on the supply voltage until installation is complete and all connecting cables are connected to the device and control.

Wire cross-sections in the supply cable from the customer's power system must be implemented in accordance with the applicable standards.

6.4 Connection diagram



NOTE

The recommended connecting cables and their associated technical data can be found on the online product page.

The product page can be accessed via the **SICK Product ID: pid.sick.com/{P/N}/{S/N}**

{P/N} corresponds to the part number of the product, see type label.

{S/N} corresponds to the serial number of the product, see type label (if indicated).

6.4.1 TiMxxxP-21xxxxx

"Power/I/O" connection

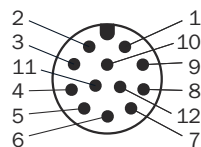

Table 5: Male connector, M12, 12-pin, A-coded

Pin	Signal	Function	Wire colors for connecting cable part no. 6054974 (5 m), 6054973 (10 m), 6054972 (20 m) ¹⁾
1	GND	Ground	Blue
2	DC 9 V ... 28 V	Supply voltage	Brown
3	IN 1	Digital input 1	Red
4	IN 2	Digital input 2	Green
5	OUT 1	Digital output 1	Pink
6	OUT 2	Digital output 2	Yellow
7	OUT 3	Digital output 3	Black
8	OUT 4	Digital output 4	Gray
9	INGND	Common ground for all inputs	White
10	IN 3	Digital input 3	Violet
11	IN 4	Digital input 4	Gray and pink
12	-	Reserved, do not wire this PIN!	Rot and blue
-	-	Shielding	-

¹⁾ Example values when using the specified connecting cable(s). Signal assignment and wire colors can vary when using other connecting cables.

"Ethernet" connection

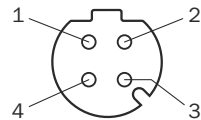

Table 6: Female connector, 4-pin, D-coded

Contact	Labeling	Description
1	TX+	Sender+
2	RX+	Receiver+
3	TX-	Sender-
4	RX-	Receiver-

6.4.2 USB interface

The Ethernet interface is recommended as a communication interface.

If using the USB interface, please note:

- Use a high-speed USB cable, maximum length of cable: 3 m.
- The connection may be interrupted due to ESD/EMC influences. If necessary: Disconnect USB cable from the device, then reconnect it.

6.5 Connecting the device electrically



NOTICE

Observe the wiring instructions, see ["Wiring instructions"](#), page 27.

1. Ensure the voltage supply is not connected.
2. Connect the device according to the connection diagram, see ["Connection diagram"](#), page 27.

6.6 Wiring digital inputs / digital outputs

Digital inputs

The device has 4 switching digital inputs.

The digital inputs are decoupled from the supply voltage of the device. They have a common reference point (IN_{GND}), meaning they are not decoupled from one another.

The structure and wiring principle of the digital inputs are shown below.

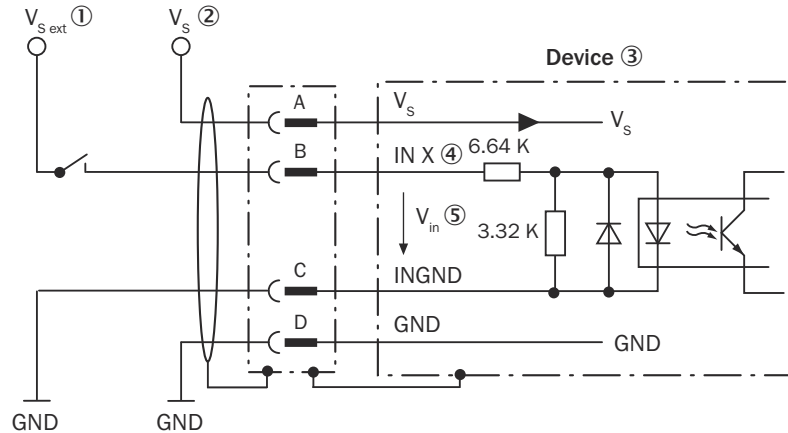

Figure 19: Wiring of digital input (PNP version)

- ① External supply voltage $V_{S\ ext}$
- ② Supply voltage V_S for device
- ③ Device
- ④ Signal IN X
- ⑤ Input voltage V_{in}

Position	Signal	TiM8xx-21xxxx (male connector M12, 12-pin): PIN
A	V_S	2
D	GND	1
C	IN_{GND}	9
B1	IN 1	3
B2	IN 2	4
B3	IN 3	10
B4	IN 4	11

Switching behavior	Current to the input starts the assigned function in the device.
Properties	Opto-decoupled Switchable with an electronic switch (PNP output) or mechanical switch
Electrical values	see "Mechanics/electronics", page 36

Digital outputs

The device has 4 switching digital outputs.

The structure and wiring principle of the digital outputs are shown below.

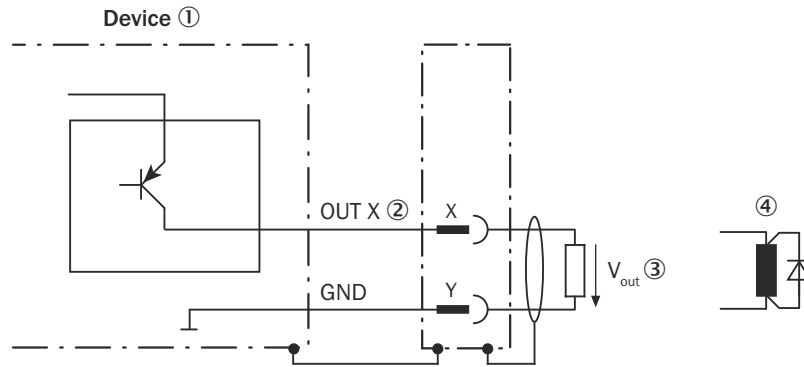

Figure 20: Wiring of digital output (PNP version)

- ① Device
- ② Signal OUT X
- ③ Output voltage V_{out}
- ④ If inductive load is present: Provide an arc-suppression switch at the digital output. Attach a freewheeling diode directly to the load for this purpose.

Position	Signal	TiM8xx-21xxxx (male connector M12, 12-pin): PIN
X1	OUT 1	5
X2	OUT 2	6
X3	OUT 3	7
X4	OUT 4	8
Y	GND	1

Switching behavior	PNP switching against supply voltage UV
Properties	Short-circuit protected and temperature protected Not electrically isolated from supply voltage U_v
Electrical values	see "Mechanics/electronics", page 36

Longer connecting cables at the digital outputs of the device should be avoided due to the resulting fall in voltage. This is calculated as follows:

$$\Delta U = (2 \times \text{length} \times \text{current}) : (\text{conductance value} \times \text{cross-section})$$

Conductance value for copper: 56 m/Ω mm².

7 Commissioning

7.1 Programming the device using SICK AppStudio

Programming of the device for the specific application is undertaken by default using the **SICK AppStudio** development environment.

Installing and starting the development environment

1. Download and install the latest version of SICK AppStudio from the online product page for the software by following the instructions provided there (supportportal.sick.com).
Administrator rights may be required on the computer to install the software.
2. Enter your personal license key to complete installation.
3. Start program. Path: **Start > All programs > SICK > SICK AppStudio**
4. Select the directory (workspace) where all data and changes are to be automatically saved.
5. Establish a connection between the software and the device via Ethernet or USB (depending on type).
The IP address **192.168.0.1** is configured by default on the device.

First steps with the device

There are various sensor apps available which can be used to demonstrate certain device properties and as a starting point for programming.

Depending on the version of the **SICK AppStudio** development environment used, the steps described below may differ.

1. Transfer the app currently located on the connected device to the created workspace using the **Transfer to working directory** context menu.
2. Activate the desired app and transfer it to and activate it on the sensor using **Run all apps** in the bar at the top.
3. Start the Internet browser (recommendation: Chrome, Firefox or Safari) and enter the IP address of the device.
4. Get to know the operating principle of the app and change parameters as needed.
5. In AppExplorer, adjust UI elements in the app under **pages** or change the operating principle of the app under **scripts** (programming in LUA).
6. Transfer the changes to the device using **Run all apps** and update the browser for visualization.

For more information, visit supportportal.sick.com.

8 Maintenance

8.1 Maintenance plan

Depending on the assignment location, the following preventive maintenance tasks may be required for the device at regular intervals:

Table 7: Maintenance plan

Maintenance work	Interval	To be carried out by
Check device and connecting cables for damage at regular intervals.	Depends on ambient conditions and climate.	Specialist
Clean housing and optics cover.	Depends on ambient conditions and climate.	Specialist
Check the screw connections and plug connectors.	Depends on the place of use, ambient conditions or operating requirements. Recommended: At least every 6 months.	Specialist
Check the mounting accessories and vibration dampers used.	Depends on the place of use, ambient conditions or operating requirements. Recommended: At least every 6 months.	Specialist
Check that all unused connections are sealed with protective caps.	Depends on ambient conditions and climate. Recommended: At least every 6 months.	Specialist

8.2 Cleaning



NOTICE

Equipment damage due to improper cleaning.

Improper cleaning may result in equipment damage.

- Only use recommended cleaning agents and tools.
- Never use sharp objects for cleaning.

- ▶ Clean the optics cover at regular intervals and in the event of contamination with a lint-free lens cloth and plastic cleaning agent. Rinse off coarse dirt first with water. The cleaning interval essentially depends on the ambient conditions.

9 Troubleshooting

9.1 Repairs

Repair work on the device may only be performed by qualified and authorized personnel from SICK AG. Interruptions or modifications to the device by the customer will invalidate any warranty claims against SICK AG.

9.2 Returns

- ▶ Only send in devices after consulting with SICK Service.
- ▶ The device must be sent in the original packaging or an equivalent padded packaging.



NOTE

To enable efficient processing and allow us to determine the cause quickly, please include the following when making a return:

- Details of the contact person
 - Description of the application
 - Description of the fault that occurred
-

9.3 Disposal

If a device can no longer be used, dispose of it in an environmentally friendly manner in accordance with the applicable country-specific waste disposal regulations. Do not dispose of the product along with household waste.



NOTICE

Danger to the environment due to improper disposal of the device.

Disposing of devices improperly may cause damage to the environment.

Therefore, observe the following information:

- Always observe the national regulations on environmental protection.
 - Separate the recyclable materials by type and place them in recycling containers.
-

10 Technical data



NOTE

The relevant online product page for your product, including technical data, dimensional drawing, and connection diagrams, can be downloaded, saved, and printed from the Internet.

The product page can be accessed via the **SICK Product ID: pid.sick.com/{P/N}/{S/N}**.
{P/N} corresponds to the part number of the product, see type label.

{S/N} corresponds to the serial number of the product, see type label (if indicated).

Please note: This documentation may contain further technical data.

10.1 Features

Variant	TiM881P
Measurement principle	HDDM+ (improved behavior for edge hits)
Application	Outdoor
Light source	Infrared (wavelength 850 nm, max. pulse power 880 mW, max. pulse width 5 ns, pulse frequency 1,500 kHz)
Laser class	1 (IEC 60825-1:2014, EN 60825-1:2014+A11:2021) Complies with 21 CFR 1040.10 and 1040.11 except for conformance with IEC 60825-1 Ed.3., as described in Laser Notice No. 56 dated 8 May 2019.
Aperture angle	270° (horizontal)
Scan field flatness ¹⁾	Typ. ± 1.5°
Scanning frequency	15 Hz
Angular resolution	0.33°
Working range	0.05 m ... 25 m
Scanning range for 5% remission	5 m (typical)
Sensing range for 10% remission	8 m (typical) ²⁾
Distance resolution	1 mm
Spot size	Spot size on the optics cover: 7 mm Divergence: 8.6 mrad (0.49°)
Number of echoes evaluated	1
Scan/frame rate	12195 measurement point(s)

¹⁾ Reference area for base of housing

²⁾ at ambient temperature < -15 °C: typ. 7.5 m

Working range diagram

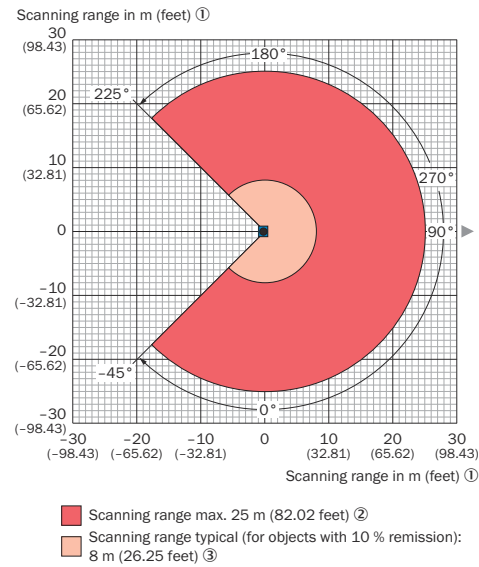

Figure 21: TiMx1x / TiMx2x working range diagram

- ① Sensing range in meters (feet)
- ② Maximum sensing range: 25 m (82.02 feet)
- ③ Typical sensing range for objects with 10% remission: 8 m (26.25 feet)

10.2 Performance

Variant	TiM881P
Response time	Typ. 1 scan: 67 ms Max. 2 scans: 134 ms ¹⁾
Power-up delay	Typ. 20 s
Detectable object shape	Almost any
Measurement error	Statistical (1 σ): < 20 mm ²⁾ Systematic: \pm 60 mm ²⁾ Temperature drift: 0.5 mm/K

¹⁾ Corresponds to max. 134 ms between +45° and +225° of the working range, max. 150 ms between -45° and +45° of the working range (see "Working range diagram", page 35).
²⁾ Typical value at room temperature and up to a sensing range of 10 m at 90% remission, real value depends on ambient conditions, temperature drift: 0.5 mm/K

10.3 Interfaces

Variant	TiM881P
Ethernet	TCP/IP Max. data transmission rate: 10 Mbit and 100 Mbit Length of cable: max. 100 m
USB	Type: Micro-USB
Digital inputs	4 (PNP)
Digital outputs	4 (PNP)
Optical indicators	2 LEDs

Variant	TiM881P
Control elements	Pushbuttons

10.4 Mechanics/electronics

Variant	TiM881P
Electrical connection	1 x Ethernet connection, 4-pin M12 female connector 1 x voltage supply connection, 12-pin M12 male connector 1 x micro USB female connector, type B
Supply voltage	9 V DC ... 28 V DC SELV and PELV acc. to IEC 60364-4-41
Power consumption	4 W (typical), with unloaded digital outputs, incl. start-up current Max. 16 W with 4 loaded digital outputs
Input voltage	Low: $V_{in} \leq 2 \text{ V}$; $I_{in} \leq 0.3 \text{ mA}$ High: $8 \text{ V} \leq V_{in} \leq 32 \text{ V}$; $0.7 \text{ mA} \leq I_{in} \leq 5 \text{ mA}$
Output voltage	Low: $0 \text{ V} \leq V_{out} \leq 2 \text{ V}$ High: $(V_S - 2 \text{ V}) \leq V_{out} \leq V_S$; $I_{out} \leq 100 \text{ mA}$
Housing	Base part: Aluminum die cast Optics cover: Polycarbonate with scratch-resistant coating
Housing color	Gray (RAL 7032)
Electrical safety	According to IEC 61010-1 (ed.3)
Enclosure rating	IP67 (IEC 60529:1989+AMD1:1999+AMD2:2013), only valid with closed "Aux interface" plastic cover
Protection class	III (IEC 61140:2016-1)
Weight	250 g, without connecting cables
Dimensions (L x W x H)	60 mm x 60 mm x 86 mm
MTTF _D	Mean time to dangerous failure: 100 years, at 25 °C ambient temperature (EN ISO 13849-1:2015)

10.5 Ambient data

Variant	TiM881P
Object remission	4% ... 1,000% (reflectors)
Electromagnetic compatibility (EMC)	IEC 61000-6-3:2006+AMD1:2010, IEC 61000-6-2:2005
Vibration resistance	Sine resonance scan: 10 Hz ... 1,000 Hz (IEC 60068-2-6:2007) Sine test: 10 Hz ... 500 Hz; 5 g; 10 frequency cycles (IEC 60068-2-6:2007) Noise test: 10 ... 250 Hz; 4.24 grms, 5 h (IEC 60068-2-64:2008)
Shock resistance	50 g; 11 ms; 6 shocks/axis 25 g; 6 ms; 2,000 shocks/axis 50 g; 3 ms; 10,000 shocks/axis (IEC 60068-2-27:2008)
Ambient temperature	Commissioning/switching on: -10 °C ... +50 °C Operation: -25 °C ... +50 °C Storage: -40 °C ... +75 °C

Variant	TiM881P
Ambient humidity	Operation: ≤ 80%, non-condensing ≤ 95%, non-condensing (EN 60068-2-30:2005)
Ambient light immunity	80,000 lx (indirect exposure)
Altitude	< 5,000 m above sea level
Ambient conditions	Contamination level 3 outside the housing (EN 61010-1:2011-07)
Damp heat	+25 °C ... +55 °C, 95% r.h., 6 cycles (EN 60068-2-30:2005)
Temperature change	-25 °C... +50 °C, 10 cycles (EN 60068-2-14: 2009)

11 Accessories

**NOTE**

On the product page you will find accessories and, if applicable, related installation information for your product.

The product page can be accessed via the **SICK Product ID: pid.sick.com/{P/N}/{S/N}**

{P/N} corresponds to the part number of the product, see type label.

{S/N} corresponds to the serial number of the product, see type label (if indicated).

12 Annex

12.1 Declarations of conformity and certificates

You can download declarations of conformity and certificates via the product page.

The product page can be accessed via the **SICK Product ID: pid.sick.com/{P/N}/{S/N}**

{P/N} corresponds to the part number of the product, see type label.

{S/N} corresponds to the serial number of the product, see type label (if indicated).

12.2 Licenses

SICK uses open source software which is published by the rights holders under a free license. Among others, the following license types are used: GNU General Public License (GPL version 2, GPL version 3), GNU Lesser General Public License (LGPL), MIT license, zlib license and licenses derived from the BSD license.

This program is provided for general use without warranty of any kind. This warranty disclaimer also extends to the implicit assurance of marketability or suitability of the program for a particular purpose.

More details can be found in the GNU General Public License.

For license texts see www.sick.com/licensetexts.

Printed copies of the license texts are also available on request.

Australia

Phone +61 (3) 9457 0600
1800 33 48 02 – tollfree
E-Mail sales@sick.com.au

Austria

Phone +43 (0) 2236 62288-0
E-Mail office@sick.at

Belgium/Luxembourg

Phone +32 (0) 2 466 55 66
E-Mail info@sick.be

Brazil

Phone +55 11 3215-4900
E-Mail comercial@sick.com.br

Canada

Phone +1 905.771.1444
E-Mail cs.canada@sick.com

Czech Republic

Phone +420 234 719 500
E-Mail sick@sick.cz

Chile

Phone +56 (2) 2274 7430
E-Mail chile@sick.com

China

Phone +86 20 2882 3600
E-Mail info.china@sick.net.cn

Denmark

Phone +45 45 82 64 00
E-Mail sick@sick.dk

Finland

Phone +358-9-25 15 800
E-Mail sick@sick.fi

France

Phone +33 1 64 62 35 00
E-Mail info@sick.fr

Germany

Phone +49 (0) 2 11 53 010
E-Mail info@sick.de

Greece

Phone +30 210 6825100
E-Mail office@sick.com.gr

Hong Kong

Phone +852 2153 6300
E-Mail ghk@sick.com.hk

Hungary

Phone +36 1 371 2680
E-Mail erteakesites@sick.hu

India

Phone +91-22-6119 8900
E-Mail info@sick-india.com

Israel

Phone +972 97110 11
E-Mail info@sick-sensors.com

Italy

Phone +39 02 27 43 41
E-Mail info@sick.it

Japan

Phone +81 3 5309 2112
E-Mail support@sick.jp

Malaysia

Phone +603-8080 7425
E-Mail enquiry.my@sick.com

Mexico

Phone +52 (472) 748 9451
E-Mail mexico@sick.com

Netherlands

Phone +31 (0) 30 204 40 00
E-Mail info@sick.nl

New Zealand

Phone +64 9 415 0459
0800 222 278 – tollfree
E-Mail sales@sick.co.nz

Norway

Phone +47 67 81 50 00
E-Mail sick@sick.no

Poland

Phone +48 22 539 41 00
E-Mail info@sick.pl

Romania

Phone +40 356-17 11 20
E-Mail office@sick.ro

Singapore

Phone +65 6744 3732
E-Mail sales.gsg@sick.com

Slovakia

Phone +421 482 901 201
E-Mail mail@sick-sk.sk

Slovenia

Phone +386 591 78849
E-Mail office@sick.si

South Africa

Phone +27 10 060 0550
E-Mail info@sickautomation.co.za

South Korea

Phone +82 2 786 6321/4
E-Mail infokorea@sick.com

Spain

Phone +34 93 480 31 00
E-Mail info@sick.es

Sweden

Phone +46 10 110 10 00
E-Mail info@sick.se

Switzerland

Phone +41 41 619 29 39
E-Mail contact@sick.ch

Taiwan

Phone +886-2-2375-6288
E-Mail sales@sick.com.tw

Thailand

Phone +66 2 645 0009
E-Mail marcom.th@sick.com

Turkey

Phone +90 (216) 528 50 00
E-Mail info@sick.com.tr

United Arab Emirates

Phone +971 (0) 4 88 65 878
E-Mail contact@sick.ae

United Kingdom

Phone +44 (0)17278 31121
E-Mail info@sick.co.uk

USA

Phone +1 800.325.7425
E-Mail info@sick.com

Vietnam

Phone +65 6744 3732
E-Mail sales.gsg@sick.com

Detailed addresses and further locations at www.sick.com