

i200 Lock

Safety locking device

SICK
Sensor Intelligence.



Described product

i200 Lock

Manufacturer

SICK AG
Erwin-Sick-Str. 1
79183 Waldkirch
Germany

Legal information

This work is protected by copyright. Any rights derived from the copyright shall be reserved for SICK AG. Reproduction of this document or parts of this document is only permissible within the limits of the legal determination of Copyright Law. Any modification, abridgment or translation of this document is prohibited without the express written permission of SICK AG.

The trademarks stated in this document are the property of their respective owner.

© SICK AG. All rights reserved.

Original document

This document is an original document of SICK AG.



Contents

1	About this document.....	5
1.1	Scope.....	5
1.2	Additional information.....	5
1.3	Symbols and document conventions.....	5
2	Safety information.....	7
2.1	General safety notes.....	7
2.2	Intended use.....	7
2.3	Requirements for the qualification of personnel.....	7
3	Product description.....	8
3.1	Setup and function.....	8
3.2	Product characteristics.....	8
3.3	Symbols on the product.....	9
3.4	Manual unlocking.....	9
4	Project planning.....	11
4.1	Manufacturer of the machine.....	11
4.2	Operator of the machine.....	12
4.3	Design.....	12
4.4	Integrating into the electrical control.....	12
4.5	Testing plan.....	12
5	Mounting.....	14
5.1	Safety.....	14
5.2	Converting the actuating head.....	14
5.3	Mounting.....	15
5.4	Protection from environmental influences.....	15
6	Electrical installation.....	16
6.1	Safety.....	16
6.2	Pin assignment.....	16
6.3	System connection (cable entry).....	16
7	Commissioning.....	18
7.1	Testing.....	18
7.2	Recurring technical checks.....	18
8	Decommissioning.....	20
8.1	Disposal.....	20
9	Technical data.....	21
9.1	Technical data.....	21
9.2	Dimensional drawings.....	22

10	Ordering information.....	23
10.1	Ordering information.....	23
11	Accessories.....	24
11.1	Actuator.....	24
11.2	Additional accessories.....	24
12	Annex.....	25
12.1	Compliance with EU directives.....	25

1 About this document

1.1 Scope

These operating instructions are valid for all i200 Lock safety locking devices.

This document is included with the following SICK part numbers (this document in all available language versions):

8022224

1.2 Additional information

www.sick.com

The following information is available on the Internet:

- This document in other languages
- Data sheets and application examples
- CAD data and dimensional drawings
- Certificates (e.g. EU declaration of conformity)
- Guide for Safe Machinery Six steps to a safe machine

1.3 Symbols and document conventions

The following symbols and conventions are used in this document:

Safety notes and other notes



DANGER

Indicates a situation presenting imminent danger, which will lead to death or serious injuries if not prevented.



WARNING

Indicates a situation presenting possible danger, which may lead to death or serious injuries if not prevented.



CAUTION

Indicates a situation presenting possible danger, which may lead to moderate or minor injuries if not prevented.



NOTICE

Indicates a situation presenting possible danger, which may lead to property damage if not prevented.



NOTE

Indicates useful tips and recommendations.

Instructions to action

- ▶ The arrow denotes instructions to action.
- 1. The sequence of instructions for action is numbered.
- 2. Follow the order in which the numbered instructions are given.
- ✓ The check mark denotes the result of an instruction.

LED symbols

These symbols indicate the status of an LED:

- The LED is off.
- ◐ The LED is flashing.
- The LED is illuminated continuously.

2 Safety information

2.1 General safety notes

The safety locking device must be configured and operated correctly by qualified safety personnel according to the machine requirements.

2.2 Intended use

When used in conjunction with a movable physical guard and the machine controller, the safety locking device prevents the protective device from being opened while a dangerous machine function is being executed.

The safety locking device may only be used on the machine on which it was configured, mounted, installed, and commissioned by qualified safety personnel in accordance with these operating instructions.

Incorrect use, improper modification of or tampering with the safety locking device will invalidate any warranty from SICK AG; in addition, any responsibility and liability of SICK AG for damage and secondary damage caused by this is excluded.



NOTE

The safety locking device is also suitable for process protection.

2.3 Requirements for the qualification of personnel

The safety locking device must be configured, installed, connected, commissioned, and serviced only by qualified safety personnel.

Project planning

For project planning, a person is considered competent when he/she has expertise and experience in the selection and use of protective devices on machines and is familiar with the relevant technical rules and national work safety regulations.

Mechanical mounting, electrical installation, and commissioning

For the task, a person is considered qualified when he/she has the expertise and experience in the relevant field and is sufficiently familiar with the application of the protective device on the machine to be able to assess whether it is in an operationally safe state.

Operation and maintenance

For operation and maintenance, a person is considered competent when he/she has the expertise and experience in the relevant field and is sufficiently familiar with the application of the protective device on the machine and has been instructed by the machine operator in its operation.

3 Product description

3.1 Setup and function

The safety locking device is an interlocking device consisting of a mechanically-actuated position switch and a coded actuator. The actuator has a lower coding level. The position switch contains a rotating switching cylinder which the actuator grips during closing. The switching cylinder is locked or unlocked electromagnetically (variant-dependent).

When inserting and removing the actuator, switching contacts for door monitoring are opened and closed. When locking and unlocking the locking device, switching contacts for locking device monitoring are opened and closed.

If the locking device is locked, the actuator cannot be removed from the actuating head. The locking device can only be locked when the protective device is closed.

3.2 Product characteristics

3.2.1 Product variants

The safety locking device is delivered in different variants. You will find an overview of important distinguishing features of the variants in the following.

- Locking principle: operating or standby current
- Type of contacts for locking device monitoring

Complete overview of all variants: [see "Ordering information", page 23](#)

Standby current locking principle

i200-M

- Locking locking device: close protective device, no voltage on the magnet
- Unlocking locking device: apply voltage to magnet

If voltage is interrupted at the magnet, the locking device remains locked and the protective device cannot be opened immediately.



WARNING

The locking device locks even when voltage is not present

People could get trapped.

- ▶ If people are in the hazardous area, do not close the protective device even voltage is not present.
-

Operating current locking principle

i200-E

- Locking locking device: apply voltage to magnet
- Unlocking locking device: disconnect voltage from magnet

If voltage is disconnected at the magnet, the locking device is unlocked and the protective device can be opened immediately.



DANGER

Hazard due to lack of effectiveness of the protective device

In the event of a voltage drop, the safety locking device unlocks regardless of whether the dangerous state of the machine has ended.

- ▶ Assess the risk of accident. Use for protecting people requires correct project planning.

3.2.2 Locking device monitoring

All variants feature at least 1 positive opening normally closed contact for locking device monitoring. The output state changes when locking or unlocking the locking device.

Variants with 2 positive opening normally closed contacts for locking device monitoring are recommended to protect people.

3.2.3 Door monitoring

All versions feature 3 contacts for door monitoring. 2 contacts are positive opening normally closed contacts. 1 contact is a normally open contact. The output state changes when opening or closing the protective device.

3.2.4 Status indicators

The safety locking device outputs the status of the locking device using the light emitting diode.

Table 1: Status LEDs

Light emitting diode status	Meaning
●	Voltage is present on the magnet for the locking device. With standby current locking principle: locking device unlocked. With operating current locking principle: locking device locked with inserted actuator.
○	No voltage is present on the magnet for the locking device. With standby current locking principle: locking device locked with inserted actuator. With operating current locking principle: locking device unlocked.

3.3 Symbols on the product

Table 2: Symbols on the product

Symbol	Meaning
	Positive opening normally closed contact for locking device monitoring
	Positive opening normally closed contact for door monitoring

3.4 Manual unlocking

In some situations, it necessary to unlock the locking device manually (e.g. is faults are present). After unlocking, a function test must be performed.

Mechanical unlocking mechanism

With the mechanical unlocking mechanism, the safety locking device can be unlocked regardless of the status.

When actuating the mechanical unlocking mechanism, the contacts for locking device monitoring open. A stop command must be generated.

Actuating the mechanical unlocking mechanism

- ▶ Ensure tensile stress is not applied on the actuator.
- ▶ Loosen safety screw with the screwdriver.
- ▶ Insert insulated screwdriver with maximum diameter of 2.5 mm into the opening and activate the mechanical unlocking mechanism.
- ▶ Open protective device with mechanical unlocking mechanism activated.
- ▶ Reinsert safety screw.

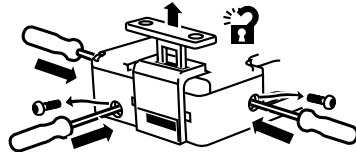

Figure 1: Mechanical unlocking mechanism

4 Project planning

4.1 Manufacturer of the machine



DANGER

Failure to comply with manufacturer's obligations

Hazard due to lack of effectiveness of the protective device

- ▶ Carry out a risk assessment before using the safety locking device.
- ▶ Do not tamper with or modify the components of the safety locking device.
- ▶ Make sure that the safety locking device is only repaired by the manufacturer or by someone authorized by the manufacturer. Improper repair can lead to a loss of the protective function.
- ▶ Make sure that switch-on commands which bring about a dangerous state of the machine are not enabled until the protective device is closed and the lock is activated.
- ▶ Make sure that the lock is not deactivated until the dangerous state of the machine has stopped.
- ▶ Make sure that closing a protective device and activating the lock does not cause a dangerous machine function to start by itself. This must be controlled by a separate start command.
- ▶ The safety locking device must not be bypassed (contacts jumpered), turned away, removed, or rendered ineffective in any other way. Take measures to reduce bypassing options as necessary.

If several devices are switched in succession and the simplified process according to ISO 13849 is used to determine the performance level (PL), the PL may be reduced.

A logical series connection of safe contacts may be possible up to PL d under certain circumstances. For more detailed information, see ISO TR 24119.

The safety locking device is designed so that internal errors according to ISO 13849-2, Table A4, can be ruled out.

Observe EN ISO 14119 for using interlocking devices associated with physical guards.

4.1.1 Application of the safety locking device to protect people

At least one safe contact must be used for locking device monitoring (contact assignment [see table 3](#)).



4.1.2 Application of the safety locking device for process protection

At least one safe contact must be used for door monitoring.



Contacts for locking device monitoring can also be used (pin assignment [see table 3](#)).



4.2 Operator of the machine



DANGER

Failure to observe operator obligations

Hazard due to lack of effectiveness of the protective device

- ▶ Changes to the machine and changes to the mechanical mounting of the safety locking device necessitate a new risk assessment. The results of this risk assessment may require the operator of the machine to meet a manufacturer's obligations.
 - ▶ Apart from the procedures described in this document, the components of the safety locking device must not be opened or modified.
 - ▶ Do not carry out any repair work on components. Improper repair of the safety locking device can lead to a loss of the protective function.
 - ▶ Make sure that replacement actuators are not used for bypassing. Restrict access to actuators.
-

4.3 Design



DANGER

Bypassing the protective device

Hazard due to lack of effectiveness of the protective device

- ▶ Eliminate any temptation to tamper with the safety locking device by implementing measures such as the following:
 - Attach safety switches with a cover or with shielding, or ensure they are out of reach.
 - Cover the safety switch and the actuator with additional equipment or protect them against access. Cover the sensor and the actuator with additional equipment or protect them against access.
-

4.3.1 Selection of the actuator



NOTICE

Selecting unsuitable actuators or improper mounting can damage the device.

- ▶ Select the right actuator (see table 7).
 - ▶ Pay attention to the door radius and mounting options.
-

4.4 Integrating into the electrical control

Switch-on commands which bring about a dangerous state of the machine must not be enabled until the protective device is closed and the lock is activated. The lock must not be deactivated until the dangerous state has ended. Depending on the safety concept, the signal is analyzed by, e.g., safety relays or a safety controller.

The connected controller and all devices responsible for safety must comply with the required performance level and the required category (for example according to ISO 13849-1).

4.5 Testing plan

The safety locking device must be tested by appropriately qualified safety personnel when commissioning, after modifications, and at regular intervals.

The regular thorough checks serve to investigate the effectiveness of the safety locking device and discover defects because of modifications or external influences (such as damage or tampering).

The manufacturer and user must define the type and frequency of the thorough checks on the machine on the basis of the application conditions and the risk assessment. Determination of the thorough checks must be documented in a traceable manner.

5 Mounting

5.1 Safety

**DANGER**

Hazard due to unexpected starting of the machine

Death or severe injury

- ▶ Make sure that the dangerous state of the machine is and remains switched off.
-

**DANGER**

Bypassing the protective device

Hazard due to lack of effectiveness of the protective device

- ▶ Eliminate any temptation to tamper with the safety locking device by taking at least one of the following measures:
 - Attach safety switches with a cover or with shielding, or ensure they are out of reach.
 - If possible, use permanent mounting methods for actuators (e.g., welding, glue, disposable screws, or rivets).
-

**NOTICE**

If incorrectly installed or the ambient conditions are not suitable, the safety locking device can get damaged.

- ▶ Arrange the safety switch and actuator so that damage due to unintentional outside influences is prevented.
 - ▶ Do not use safety switch and actuator.
 - ▶ The set-up and mounting of the safety switch and actuator must be stable enough to maintain proper operation.
 - ▶ Use only reliable mounting elements that can only be removed with tools.
 - ▶ If an opening is created in the physical guard due to alignment errors, it must not impair the protective function.
-

5.2 Converting the actuating head

1. Insert the actuator into the actuating head.
2. Loosen screws on the cover and lift the cover.
3. Remove plastic dowel pins and loosen actuating head.
4. Turn the actuating head in the desired direction.
5. Depending on the locking forces, fasten the actuating head with plastic dowel pins or metal bolts.
6. Rotate metal insert by 180° by loosening the 2 fixing screws.
7. Seal unused actuation slots with the supplied slot covers.

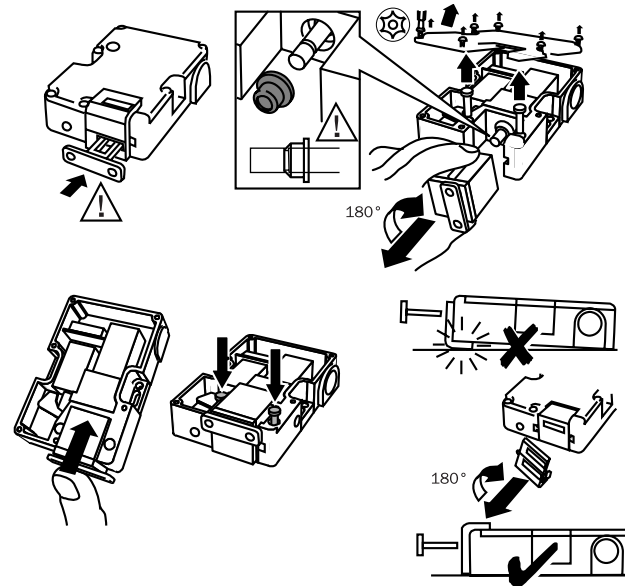

5.3 Mounting

1. Insert the actuator into the actuating head.
2. Connect the safety switch to the fixed part of the protective device with positive locking with 2 M5 screws. Tightening torque: 1.4 Nm.
3. In addition, insert 2 M5 coiled spring pins to fasten the safety switch.
4. Connect the actuator permanently to the moving part of the protective device so it cannot be disengaged.
5. Fit an additional stop for the moving part of the protective device.

5.4 Protection from environmental influences

The prerequisite for a proper and permanent safety function is protection of the actuating head from foreign bodies such as chips, sand, beams of light, etc.

When doing painting work, cover the actuation slot, the actuator and the type label.

6 Electrical installation

6.1 Safety



DANGER

Hazard due to electrical voltage

Death or severe injury

- ▶ Make sure that the machine and the connecting cables of the safety locking device are and remain disconnected from the power supply during the electrical installation.



DANGER

Incorrect safety locking device connection

Loss of safety function

- ▶ With insulation material or connection slots, pay attention to the temperature resistance and mechanical load capability.
- ▶ If different voltages are used between the contact pairs and the magnet coil (e.g. 230 V and 24 V), when wiring in the terminal compartment, make sure safe separation is always present.
- ▶ For safety functions, use only safe contacts for locking device monitoring and door monitoring.



6.2 Pin assignment

Table 3: Switching elements and switching functions

	Actuator inserted		Actuator removed
	Locked	Unlocked	
i200-*02332			
i200-M0413 ²⁾			
All variants	E1: +24 V DC magnet coil voltage supply (locking device) E2: +0 V DC magnet coil voltage supply (locking device)		

- 1) The bridge between contacts 12 and 41 must be removed to in order to enable locking device and door monitoring.
- 2) The bridges between contacts 12 and 41 and 22 and 51 must be removed to in order to enable locking device and door monitoring.

6.3 System connection (cable entry)

1. Open desired insertion opening with a suitable tool.
2. Mount the cable gland with corresponding enclosure rating.
3. Connect contacts (contact assignment [see table 3](#)).
 - Connect all live contacts to one side of the contact block.
 - Operate all contact pairs and the magnet coil in the same voltage range.
 - Protect the magnet coil separately.
 - Tighten terminals to 1.0 Nm.

4. Pay attention to tightness of the cable entries.
5. Close switch cover and fasten it (tightening torque 1.2 Nm).

7 Commissioning

7.1 Testing

**DANGER**

Hazard due to unexpected starting of the machine

Death or severe injury

- ▶ Before carrying out the functional test, make sure that there are no people in the hazardous area.

Approach

Check that the device is functioning properly after installation and after every fault. To do this, proceed as follows:

Mechanical functional test

- ▶ Open the protective device and close it again. The components of the safety locking device must not collide with other parts. When the protective device is closed, the actuator must be in a position which enables the lock to be actuated.

Electrical functional test

1. Switch on the supply voltage.
2. Close all protective devices and activate the locks. The machine must not start up on its own.
3. Check the lock. It must not be possible to open the protective device.
4. Start the machine function.
5. Make sure that the lock cannot be deactivated as long as the dangerous machine function is active.
6. Stop the machine function and deactivate the lock.
7. Check whether the protective device is kept locked until there is no more risk of injury (e.g., due to run-on movements).
8. Check the restart interlock. The machine function must not start while the lock is deactivated.
9. Repeat steps 3 to 8 individually for each protective device.

Complementary information**NOTE**

With the version in accordance with the power to lock principle, an active lock command can be simulated by applying 24 V DC voltage to the “Lock input” contact.

7.2 Recurring technical checks

**DANGER**

Insufficient checks or incorrect repair

Hazard due to lack of effectiveness of the protective device

- ▶ In the event of wear or damage, replace the entire safety locking device with actuator. Never replace individual parts or assemblies.
- ▶ Check the safety locking device following the inspection intervals specified in the national rules and regulations.

The following checks must be done to ensure permanent and proper function:

- Proper switching function
- Safe mounting for all components
- No damage, contamination, deposits or wear
- Tightness of cable entries
- No loose cable connections or plug connectors
- No manipulation by employees

8 Decommissioning

8.1 Disposal

Approach

- ▶ Always dispose of unusable devices in accordance with national waste disposal regulations.



Complementary information

SICK will be glad to help you dispose of these devices on request.

9 Technical data

9.1 Technical data

Table 4: Features

Features	
	Variant with cable entry
Housing material	Fiberglass-reinforced polyester
Enclosure rating (IEC 60529)	IP 65
Mechanical service life	1×10^6
B _{10d} (EN ISO 13849)	2×10^6 Switching operation with small load
Type	Type 2 (EN ISO 14119)
Coding level of the actuator	Low coding level (EN ISO 14119)
Ambient operating temperature	-20 °C ... +60 °C
Connection type	3 × M20
Max. actuation speed	9,6 m × min ⁻¹
Max. actuation frequency	3,600 × h ⁻¹
Pollution degree (external, according to EN 60947)	3 × (industry)
Max. force against which unlocking is possible	50 N
Max. retaining force, unlocked	30 N
Locking force F _{max}	
Mounting with plastic locating pins	1,950 N
Mounting with metal bolts	2,600 N
Locking force F _{Zh} according to (EN ISO 14119) (F _{Zh} = F _{max} / 1.3)	
Mounting with plastic locating pins	1,500 N
Mounting with metal bolts	2,000 N
Minimum door radii	see table 7

Table 5: Electrical data

Electrical data	
Thermal current I _{th}	10 A
Switching principle	Slow action switching element
Wire cross-section, (rigid/flexible)	0.34 mm ² ... 1.5 mm ²
Rated insulation voltage U _i	250 V
Rated impulse withstand voltage U _{imp}	2.5 kV
Utilization category (IEC 60947-5-1)	AC-15: 230 V, 3 A; DC-13: 24 V, 3 A
Min. switching voltage ¹⁾	5 V
Min. switching current at 24 V DC	5 mA
Short-circuit protection (control fuse) (IEC 60269)	6 A gG
Solenoid supply voltage (+10% ... -15%)	AC/DC 24 V
Max. solenoid power	7 W
ED switch-on time	100%

1) At 10 mA.

9.2 Dimensional drawings

i200 Lock

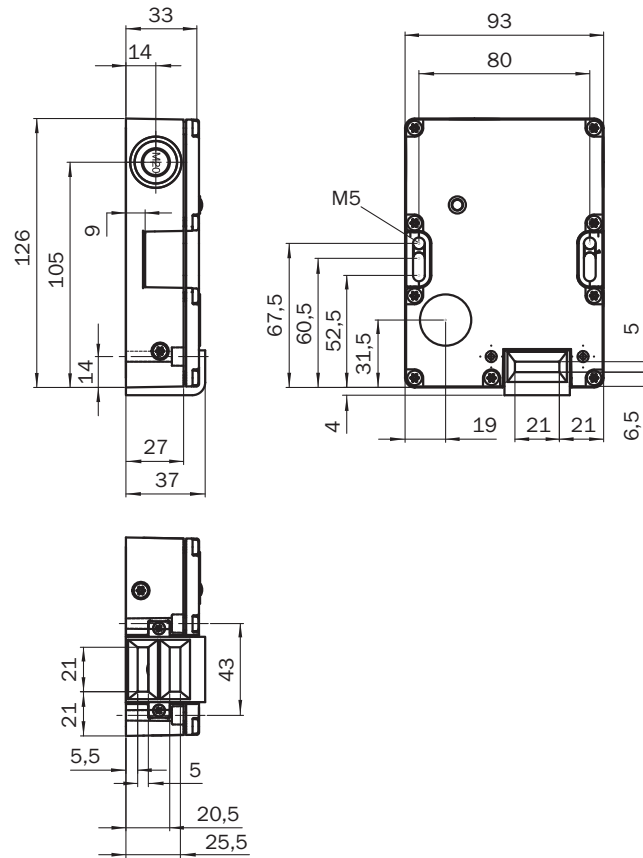

Actuator

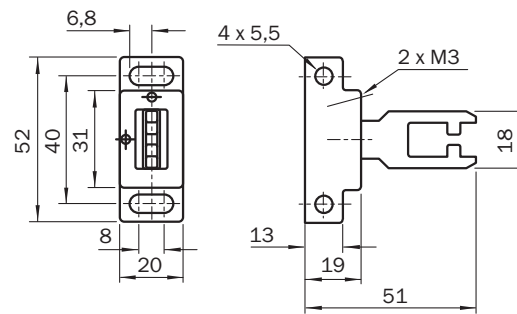

Figure 2: iE200-F1

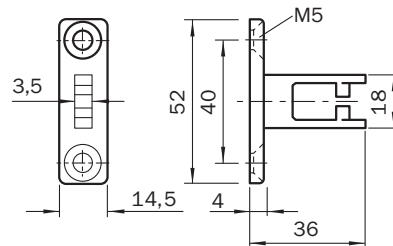

Figure 3: iE200-S1

10 Ordering information

10.1 Ordering information

Table 6: Ordering information, i200 Lock

Locking principle	Locking device monitoring		Type code	Part number
	Positive opening normally closed contact	Normally open		
Standby current	1	1	i200-M0323 Lock	6025113
Standby current	2	0	i200-M0413 Lock	6025115
Operating current	1	1	i200-E0323 Lock	6026140

11 Accessories

11.1 Actuator

Table 7: Actuator

Design	Actuation option	Door radius	Type code	Part number
Straight	Rigid	≥ 160 mm	iE200-S1	5308758
Radial	Fully flexible	≥ 80 mm	iE200-F1	5308759
Bolt actuator, straight	Rigid	≥ 160 mm	iE200-B1	5308760

11.2 Additional accessories

Table 8: Additional accessories

Designation	Type code	Part number
Cable gland	M20 screw connection	5309164

12 Annex

12.1 Compliance with EU directives

EU declaration of conformity (extract)

The undersigned, representing the manufacturer, herewith declares that the product is in conformity with the provisions of the following EU directive(s) (including all applicable amendments), and that the standards and/or technical specifications stated in the EU declaration of conformity have been used as a basis for this.

Complete EU declaration of conformity for download

You can call up the EU declaration of conformity and the current operating instructions for the protective device by entering the part number in the search field at www.sick.com (part number: see the type label entry in the “Ident. no.” field).

Australia

Phone +61 (3) 9457 0600
1800 33 48 02 – tollfree
E-Mail sales@sick.com.au

Austria

Phone +43 (0) 2236 62288-0
E-Mail office@sick.at

Belgium/Luxembourg

Phone +32 (0) 2 466 55 66
E-Mail info@sick.be

Brazil

Phone +55 11 3215-4900
E-Mail comercial@sick.com.br

Canada

Phone +1 905.771.1444
E-Mail cs.canada@sick.com

Czech Republic

Phone +420 2 57 91 18 50
E-Mail sick@sick.cz

Chile

Phone +56 (2) 2274 7430
E-Mail chile@sick.com

China

Phone +86 20 2882 3600
E-Mail info.china@sick.net.cn

Denmark

Phone +45 45 82 64 00
E-Mail sick@sick.dk

Finland

Phone +358-9-25 15 800
E-Mail sick@sick.fi

France

Phone +33 1 64 62 35 00
E-Mail info@sick.fr

Germany

Phone +49 (0) 2 11 53 01
E-Mail info@sick.de

Hong Kong

Phone +852 2153 6300
E-Mail ghk@sick.com.hk

Hungary

Phone +36 1 371 2680
E-Mail ertekesites@sick.hu

India

Phone +91-22-6119 8900
E-Mail info@sick-india.com

Israel

Phone +972-4-6881000
E-Mail info@sick-sensors.com

Italy

Phone +39 02 27 43 41
E-Mail info@sick.it

Japan

Phone +81 3 5309 2112
E-Mail support@sick.jp

Malaysia

Phone +603-8080 7425
E-Mail enquiry.my@sick.com

Mexico

Phone +52 (472) 748 9451
E-Mail mario.garcia@sick.com

Netherlands

Phone +31 (0) 30 229 25 44
E-Mail info@sick.nl

New Zealand

Phone +64 9 415 0459
0800 222 278 – tollfree
E-Mail sales@sick.co.nz

Norway

Phone +47 67 81 50 00
E-Mail sick@sick.no

Poland

Phone +48 22 539 41 00
E-Mail info@sick.pl

Romania

Phone +40 356-17 11 20
E-Mail office@sick.ro

Russia

Phone +7 495 283 09 90
E-Mail info@sick.ru

Singapore

Phone +65 6744 3732
E-Mail sales.gsg@sick.com

Slovakia

Phone +421 482 901 201
E-Mail mail@sick-sk.sk

Slovenia

Phone +386 591 78849
E-Mail office@sick.si

South Africa

Phone +27 (0)11 472 3733
E-Mail info@sickautomation.co.za

South Korea

Phone +82 2 786 6321
E-Mail info@sickkorea.net

Spain

Phone +34 93 480 31 00
E-Mail info@sick.es

Sweden

Phone +46 10 110 10 00
E-Mail info@sick.se

Switzerland

Phone +41 41 619 29 39
E-Mail contact@sick.ch

Taiwan

Phone +886-2-2375-6288
E-Mail sales@sick.com.tw

Thailand

Phone +66 2 645 0009
E-Mail marcom.th@sick.com

Turkey

Phone +90 (216) 528 50 00
E-Mail info@sick.com.tr

United Arab Emirates

Phone +971 (0) 4 88 65 878
E-Mail info@sick.ae

United Kingdom

Phone +44 (0)17278 31121
E-Mail info@sick.co.uk

USA

Phone +1 800.325.7425
E-Mail info@sick.com

Vietnam

Phone +65 6744 3732
E-Mail sales.gsg@sick.com

Further locations at www.sick.com

