

IME2S

Safety switches

IS-IME2S-12

SICK
Sensor Intelligence.

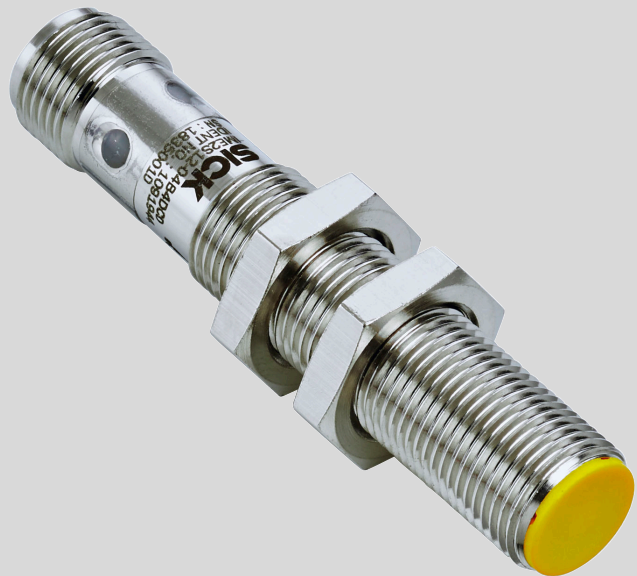

Described product

IME2S

Manufacturer

SICK AG
Erwin-Sick-Str. 1
79183 Waldkirch
Germany

Legal information

This work is protected by copyright. Any rights derived from the copyright shall be reserved for SICK AG. Reproduction of this document or parts of this document is only permissible within the limits of the legal determination of Copyright Law. Any modification, abridgment or translation of this document is prohibited without the express written permission of SICK AG.

The trademarks stated in this document are the property of their respective owner.

© SICK AG. All rights reserved.

Original document

This document is an original document of SICK AG.



Contents

1	Ordering information.....	5
1.1	Scope of delivery.....	5
1.2	Ordering information.....	5
2	About this document.....	6
2.1	Function of this document.....	6
2.2	Scope.....	6
2.3	Target groups of these operating instructions.....	6
2.4	Additional information.....	6
2.5	Symbols and document conventions.....	6
3	Safety information.....	8
3.1	General safety notes.....	8
3.2	Intended use.....	8
3.3	Improper use.....	8
3.4	Requirements for the qualification of personnel.....	8
4	Product description.....	10
4.1	Structure and function.....	10
4.2	Product characteristics.....	10
5	Project planning.....	12
5.1	Manufacturer of the machine.....	12
5.2	Operating entity of the machine.....	12
5.3	Design.....	12
5.4	Integration in the electrical control.....	14
5.5	Thorough check concept.....	14
6	Mounting.....	16
6.1	Flush mounting.....	16
7	Electrical installation.....	17
7.1	Safety.....	17
7.2	Notes on cULus.....	18
7.3	System connection (M12, 4-pin).....	18
7.4	System connection (M8, 4-pin).....	19
8	Commissioning.....	20
8.1	Safety.....	20
8.2	Switching on.....	20
8.3	Adjustment.....	20
9	Troubleshooting.....	21
9.1	Safety.....	21
9.2	Fault indicators.....	21

10	Maintenance.....	22
10.1	Cleaning.....	22
11	Decommissioning.....	23
11.1	Disposal.....	23
12	Technical data.....	24
12.1	Data sheet.....	24
12.2	Table of weights.....	26
12.3	Dimensional drawings.....	26
13	Annex.....	27
13.1	Compliance with EU directives.....	27

1 Ordering information

1.1 Scope of delivery

Scope of delivery, IME2S

- 1 × IME2S safety switch
- 2 × fixing nuts
- 1 × safety notes
- Operating instructions for download: www.sick.com

1.2 Ordering information

Table 1: IME2S ordering information

Design	Housing diameter	Sensor connection type	Structural state	Type	Part number
Cylindrical	M12	M12 male connector, 4-pin	Flush	IS-IME2S-12	1109654

2 About this document

2.1 Function of this document

These operating instructions contain the information needed during the life cycle of the safety switch.

They must be made available to all people who work with the safety switch.

2.2 Scope

These operating instructions apply only to the following safety switches:

- The IME2S product family

This document is included with the following SICK part numbers (this document in all available language versions):

8025315

2.3 Target groups of these operating instructions

Some chapters of these operating instructions are intended for certain target groups. However, the entire operating instructions are relevant for intended use of the product.

Table 2: Target groups and selected chapters of these operating instructions

Target group	Chapters of these operating instructions
Project developers (planners, developers, designers)	"Project planning", page 12 "Technical data", page 24
Installers	"Mounting", page 16
Electricians	"Electrical installation", page 17
Safety experts (such as CE authorized representatives, compliance officers, people who test and approve the application)	"Project planning", page 12 "Commissioning", page 20 "Technical data", page 24
Operators	"Troubleshooting", page 21
Maintenance personnel	"Maintenance", page 22 "Troubleshooting", page 21

2.4 Additional information

www.sick.com

The following information is available on the Internet:

- This document in other languages
- Data sheets and application examples
- CAD data and dimensional drawings
- Certificates (e.g. EU declaration of conformity)
- Guide for Safe Machinery Six steps to a safe machine

2.5 Symbols and document conventions

The following symbols and conventions are used in this document:

Safety notes and other notes

**DANGER**

Indicates a situation presenting imminent danger, which will lead to death or serious injuries if not prevented.

**WARNING**

Indicates a situation presenting possible danger, which may lead to death or serious injuries if not prevented.

**CAUTION**

Indicates a situation presenting possible danger, which may lead to moderate or minor injuries if not prevented.

**NOTICE**

Indicates a situation presenting possible danger, which may lead to property damage if not prevented.

**NOTE**

Indicates useful tips and recommendations.

Instructions to action

- ▶ The arrow denotes instructions to action.
- 1. The sequence of instructions for action is numbered.
- 2. Follow the order in which the numbered instructions are given.
- ✓ The check mark denotes the result of an instruction.

LED symbols

These symbols indicate the status of an LED:

- The LED is off.
- ◐ The LED is flashing.
- The LED is illuminated continuously.

3 Safety information

3.1 General safety notes

This chapter contains general safety information about the safety switch.

Further safety information is provided in the respective chapters to cover the specific situations in which the product may be used.



DANGER

Hazard due to lack of effectiveness of the protective device

In the case of non-compliance, it is possible that the dangerous state of the machine may not be stopped or not stopped in a timely manner.

- ▶ Please read this document carefully and make sure that you understand the content fully before working with the device.
 - ▶ Follow all safety notes in this document.
-



NOTICE

The adhesive strip above the LED displays must not be removed in order to achieve the specified enclosure rating.

3.2 Intended use

The safety switch is an inductive safety switch which is activated by actuating elements (metal objects) without making contact. The safety switch is suitable for the following applications:

- Safe position and area determination of metal objects

The safety switch is used for protecting people.

The safety switch must only be used within the limits of the prescribed and specified technical data and operating conditions at all times.

Incorrect use, improper modification or manipulation of the safety switch will invalidate any warranty from SICK; in addition, any responsibility and liability of SICK for damage and secondary damage caused by this is excluded.

3.3 Improper use

The safety switch is **not** suitable for the following applications, among others:

- Environments with increased levels of ionizing radiation
- Applications in which the safety switch is exposed to chemicals, for example cleaning in food processing.
- Outdoors (only suitable for weather-protected areas of application, Class C according to IEC 60654-1)

3.4 Requirements for the qualification of personnel

The safety switch must be configured, mounted, connected, commissioned, and serviced by qualified safety personnel only.

Project planning

For project planning, a person is considered competent when he/she has expertise and experience in the selection and use of protective devices on machines and is familiar with the relevant technical rules and national work safety regulations.

Mechanical mounting, electrical installation, and commissioning

For the task, a person is considered qualified when he/she has the expertise and experience in the relevant field and is sufficiently familiar with the application of the protective device on the machine to be able to assess whether it is in an operationally safe state.

Operation and maintenance

For operation and maintenance, a person is considered competent when he/she has the expertise and experience in the relevant field and is sufficiently familiar with the application of the protective device on the machine and has been instructed by the machine operator in its operation.

4 Product description

4.1 Structure and function

Description of operation

The safety switch is an inductive safety switch which is activated by actuating elements (metal objects) without making contact.

If an actuating element is situated between the active sensor surface and assured switch-off distance S_{ao} , safety outputs (OSSDs) are safe in the ON state. If an actuating element is situated outside assured safe switch-off distance S_{ar} , safety outputs (OSSDs) are in the OFF state.

The machine or its control must safely analyze the signals (for example using a safe control or safety relays) and stop the dangerous state.

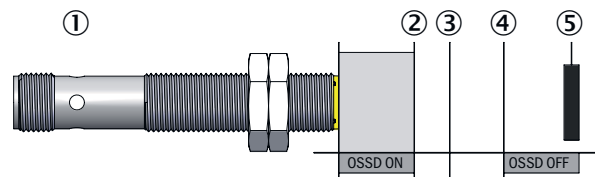

- ① Safety switches
- ② Assured switch-on distance S_{ao}
- ③ Sensing range S_n (switch-on distance under laboratory conditions)
- ④ Assured switch-off distance S_{ar}
- ⑤ Actuating element

Assured switch on distance (S_{ao})

Distance from the active sensor surface within which the presence of the actuating element can be safely detected.

The assured switch-on distance is the important value for safe applications.

Sensing range (S_n)

Is detected under laboratory conditions.

Typical sensing range of the safety switch. The sensing range can change with the shape and material of the actuating element. Manufacturing tolerances as well as external influences such as temperature or supply voltage are not considered.

Assured switch off distance (S_{ar})

Distance from the active sensor surface outside of which the presence of the actuating element is reliably detected.

4.2 Product characteristics

4.2.1 Protective functions



DANGER

Loss of cross-circuit monitoring when output load at the OSSDs is too high

Loss of safety function

- The safety switch must always be operated within the limits of the prescribed and specified technical data.

The safety switch is available for the following internal protective functions:

- Short-circuit protection at all outputs
- Cross-circuit monitoring at the OSSDs
- Overload protection at the OSSDs
- Supply voltage reverse polarity protection

4.2.2 Status indicators

LEDs on the device

The safety switch signals the operational status via an LED.

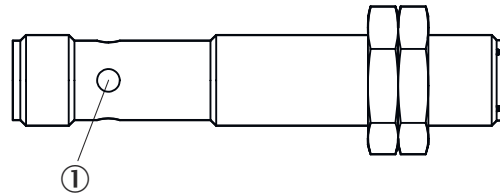

Figure 1: LED IME2S

Table 3: LED

Item	Name	Color	Purpose
①	STATE	Green/Red	Signals when an object is detected.

Further topics

- [see "Fault indicators", page 21](#)

5 Project planning

5.1 Manufacturer of the machine



DANGER

Failure to comply with manufacturer's obligations

Hazard due to lack of effectiveness of the protective device

- ▶ Carry out a risk assessment before using the safety switch.
 - ▶ Do not tamper with, open, or modify the components of the safety switch.
 - ▶ Do not repair defective devices – they must be replaced instead.
 - ▶ Make sure that switch-on commands which bring about a dangerous state of the machine are not enabled until the protective device is closed.
 - ▶ Ensure that a stop command is triggered if the actuating element is no longer detected (e.g. when the protective device is opened during a hazardous machine status).
 - ▶ The safety switches must not be circumvented (contacts bypassed), rotated away, removed, or rendered ineffective in any other way. Put measures in place to reduce possibilities for circumvention.
-

5.2 Operating entity of the machine



DANGER

Failure to observe operator obligations

Hazard due to lack of effectiveness of the protective device

- ▶ Changes to the machine and changes to the mechanical mounting of the safety switch necessitate a new risk assessment. The results of this risk assessment may require the entity operating the machine to meet the obligations of a manufacturer.
 - ▶ Apart from the procedures described in this document, the components of the safety switch must not be opened or modified.
 - ▶ Do not carry out any repair work on components. Improper repair of the safety switch can lead to a loss of the protective function.
-

5.3 Design

Important information



DANGER

Bypassing the protective device

Hazard due to lack of effectiveness of the protective device

- ▶ Avoid incentives to manipulate the safety switch by taking at least one of the following measures:
 - Attach safety switch outside of the sensing range.
 - Cover safety switch with obstacles or shield.
 - Attach safety switch at the covered position.
 - If possible, do not mount the safety switch with the active sensor surface facing upwards.
-

**DANGER**

Damage to the safety switch due to mechanical stress
Loss of safety function

- ▶ Protect the safety switch from mechanical stress such as impacts or permanent contact pressure, for example with an additional stop

Mounting location

Select the mounting location so that the safety switch is protected from impacts and mechanical pressure. If necessary, attached additional stop.

Measures to protect against unintentional actuation

The safety switch can be actuated by any metal objects such as metal chips, doors or moving machine elements. Constructive measures must be taken so that the safety switch is only actuated by the intended actuating element.

Distance

If several safety switches are mounted on the machine, they must be mounted at a minimum distance to one another.

Alignment

The safety switch can be mounted with any alignment. If the safety sensor is mounted with the sensor surface facing upwards, the risk of unintended actuation by loose metal objects (for example metal chips) or manipulation of the safety switch increases.

Further topics

- [see "Flush mounting", page 16](#)

5.3.1 Determining the sensing ranges

Sensing ranges S_{ao} , S_{ar} and S_n depend on the material and form of the actuating element. The specified values assume the following prerequisites:

- Length and width of the actuating element: Diameter of the active sensor surface
- Material thickness: 1 mm
- Material of the actuating element: Structural steel (FE360)
- Ambient temperature: 25 °C

If the actuating element consists of another material, the specified values for S_{ao} , S_{ar} and S_n must be multiplied with the respective correction factor ([see table 4, page 13](#)) (values of sensing ranges [see table 11, page 24](#)).

Table 4: Correction factor for sensing ranges S_{ao} , S_{ar} and S_n

Material	Correction factor
Mu-metal	1.2
Molded metal	1.1
Structural steel (Fe 360)	1.0
Rust-free steel (V2A, 304)	0.8
Aluminum	0.45
Copper	0.3
Brass	0.4

Example calculation

For a copper actuating element, the safe switch-off distance changes as follows:

$$S_{ar/copper} = S_{ar} * 0,3$$

5.4 Integration in the electrical control

Switch-on commands that put the machine in a dangerous state may only be activated when the safety switch detects an actuating element. When the machine goes into a dangerous state, a stop command must be triggered if no suitable object is detected. Depending on the safety concept, the signal is analyzed by safety relays or a safety controller, for example.

The connected control and all devices responsible for safety must comply with the required performance level and the required category (for example, according to EN ISO 13849-1:2015).

5.4.1 Course of the OSSD test over time

The device tests the OSSDs for self-diagnosis at regular intervals. To do this, the device switches each OSSD briefly to the OFF state and checks whether this channel is voltage-free during this time.

Make sure that the machine's control does not react to these test pulses and the machine does not switch off.

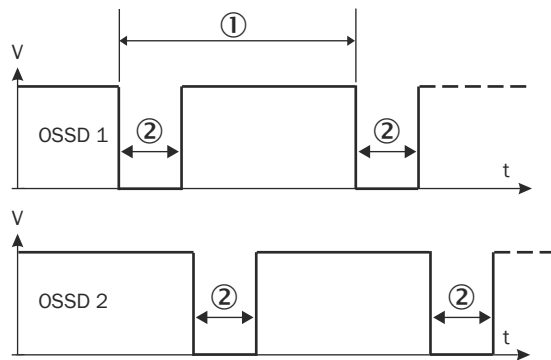

Figure 2: Course of the OSSD test over time

Legend number	Description	Value
①	Test pulse interval	Usually every 20 ms
②	Test pulse width	300 μs

5.5 Thorough check concept

The safety switch must be tested by appropriately qualified safety personnel during commissioning, after modifications, and at regular intervals; see "Requirements for the thorough check during commissioning and in certain situations", page 15.

Regular thorough checks serve to investigate the effectiveness of the safety switch and discover defects resulting from modifications or external influences (such as damage or manipulation).

The manufacturer and operating entity must define the type and frequency of the thorough checks on the machine on the basis of the application conditions and the risk assessment. The process of defining the thorough checks must be documented in a traceable manner.

5.5.1 Requirements for the thorough check during commissioning and in certain situations

The protective device and its application must be thoroughly checked in the following situations:

- Before commissioning
- After changes to the safety function
- After changes to the mounting, the alignment, or the electrical connection
- After exceptional events, such as after a manipulation has been detected, after modification of the machine, or after replacing components

The thorough check ensures the following:

- All relevant regulations are complied with and the protective device is active for all of the machine's operating modes.
- The documentation corresponds to the state of the machine, including the protective device

The thorough checks must be carried out by qualified safety personnel or specially qualified and authorized personnel and must be documented in a traceable manner.

- ▶ Check whether the protective device of the machine is effective in all operating modes in which the machine can be set.
- ▶ Make sure that operating personnel have been instructed in the function of the protective device before starting work on the machine. The machine operator has overall responsibility for the instruction, which must be carried out by qualified personnel.

5.5.2 Minimum requirements for regular thorough checks

The following thorough checks must be carried out at least once a year:

- Thorough check of the principal protective function of the safety switch
- Thorough check of assured sensing ranges S_{ar} and S_{ao}
- Thorough check for damage on the switch housing
- Thorough check for damage on the switch cables
- Thorough check for signs of misuse or manipulation on the safety switch

6 Mounting

6.1 Flush mounting

Approach

- ▶ Observe the max. tightening torque during mounting.
 - IME2S: 12 Nm

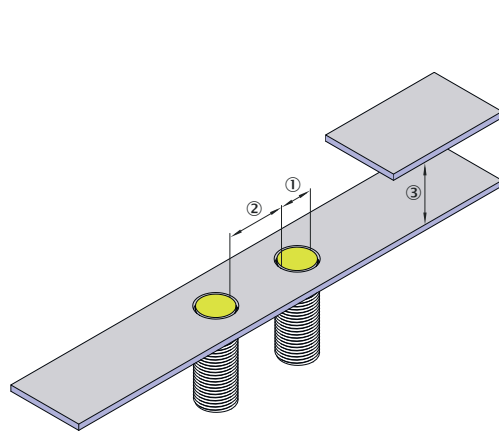

Figure 3: Spaces for flush mounting of IME2S devices

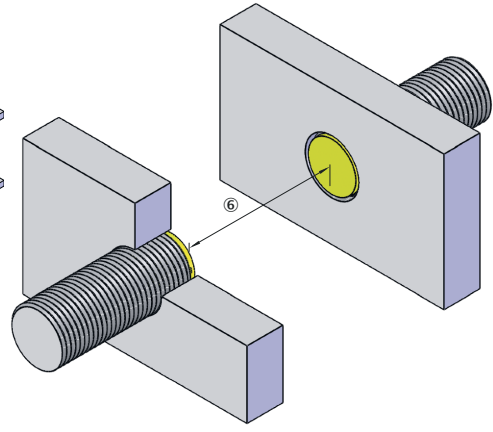

Figure 4: Space with 2 opposing IME2S safety switches

Table 5: Dimensions for flush mounting in mm

Variant	① Diameter of the safety switch	② Minimum distance to the neighboring safety switch	③ Minimum free space above the active sensor surface	⑥ Minimum distance to the opposing safety switch
IME2S12-04*****	12	> 24	> 12	> 32
General formula	-	$2 \times \textcircled{1}$	$> 3 \times S_n$	$> 8 \times S_n$

7 Electrical installation

7.1 Safety

Overview

You can directly integrate the safety switch into the machine controller via the safety outputs (OSSDs). The OSSDs indicate the ON state with the HIGH signal level (non-isolated). The OFF state is indicated with the LOW signal level.

Downstream control elements must evaluate the output signals of the protective device in such a way that the dangerous state of the machine is safely ended. Depending on the safety concept, the signal is analyzed by, e.g., safety relays or a safety controller.

Important information



DANGER

Hazard due to electrical voltage

Hazard due to unexpected starting of the machine

- ▶ Make sure that the machine is and remains disconnected from the power supply during the electrical installation.
- ▶ Make sure that the dangerous state of the machine is and remains switched off during electrical installation.
- ▶ Make sure that the outputs of the safety switch have no effect on the machine during electrical installation.



DANGER

Hazard due to lack of effectiveness of the protective device

The dangerous state may not be stopped in the event of non-compliance.

- ▶ Always connect the two OSSDs separately. The two OSSDs must not be connected to each other.
- ▶ Connect the OSSDs such that the machine controller processes both signals separately.

Isolated connection of OSSD1 and OSSD2

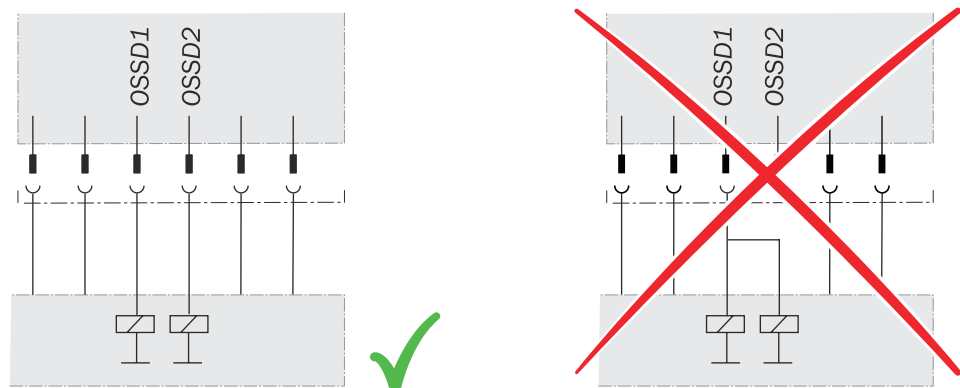

Figure 5: Dual-channel and isolated connection of OSSD1 and OSSD2

Avoiding any potential difference between load and protective device

If you connect loads to the output signal switching devices (switching outputs) that then also switch if controlled with negative voltage (e.g., electro-mechanical contactor without reverse polarity protection diode), you must connect the 0 V connections of these loads and those of the corresponding protective device separately and also directly to the same 0 V terminal strip. In the event of a fault, this is the only way to ensure that there can be no potential difference between the 0 V connections of the loads and those of the corresponding protective device.

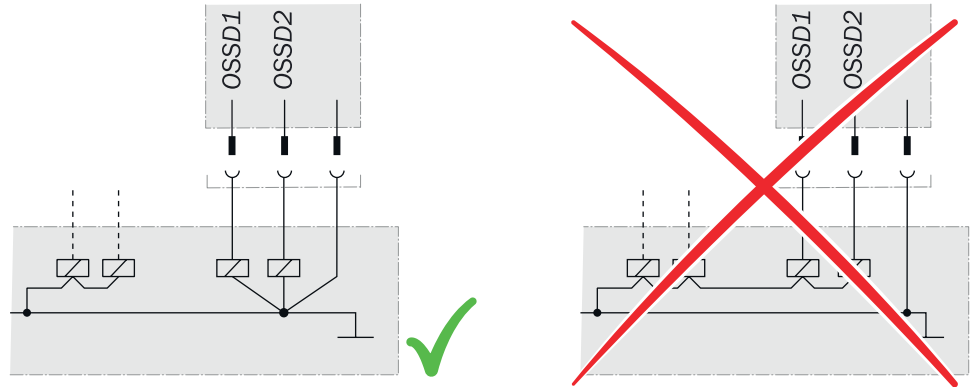

Figure 6: No potential difference between load and protective device

7.2 Notes on cULus

Important information



DANGER

Risk of burns from hot housing

- ▶ Take measures to make sure the safety switch cannot be touched during operation.

For use according to the requirements of UL 60947-5-2, the following conditions must also be met:

- The voltage supply must correspond to Class 2 in accordance with UL 508
- Voltage supply U_v secured with 1 A fuse

7.3 System connection (M12, 4-pin)

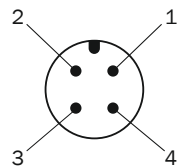

Figure 7: System connection pin assignment (male connector)

Table 6: Device connection pin assignment (male connector, M12, 4-pin, A-coded)

Pin	Wire color ¹⁾	Designation	Description
1	Brown	+24 V DC	Voltage supply 24 V DC
2	White	OSSD 1	Output OSSD1
3	Blue	0 V	Voltage supply 0 V DC
4	Black	OSSD 2	Output OSSD2

¹⁾ Applies to the extension cables recommended as accessories.

7.4 System connection (M8, 4-pin)

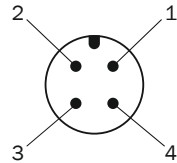

Figure 8: System connection pin assignment (male connector)

Table 7: Device connection pin assignment (male connector, M8, 4-pin, A-coded)

Pin	Wire color ¹⁾	Designation	Description
1	Brown	+24 V DC	Voltage supply 24 V DC
2	White	OSSD 1	Output OSSD1
3	Blue	0 V	Voltage supply 0 V DC
4	Black	OSSD 2	Output OSSD2

¹⁾ Applies to the extension cables recommended as accessories.

8 Commissioning

8.1 Safety



DANGER

Hazard due to lack of effectiveness of the protective device

In the case of non-compliance, it is possible that the dangerous state of the machine may not be stopped or not stopped in a timely manner.

1. Before commissioning the machine, have it checked and released by qualified safety personnel.
2. Make sure that the time for the safety requirement (closing the protective device again) is longer than the response time.

8.2 Switching on

Approach

1. Make sure that the distance of the actuating element from the sensor surface of the safety switch is greater than the assured switch-off distance.
2. Switch on the supply voltage.

As soon as the supply voltage is applied, the safety switch initializes automatically. When the STATE LED permanently lights up red, the safety switch is ready for operation.

Table 8: LED displays and OSSD status during commissioning

STATE LED	OSSDs	Device state
◐ Green/Red	OFF state	Safety switch initializes.
● Red	OFF state	The safety switch is switched on. Actuating object is not detected.
● Green	ON state	The safety switch is switched on. Actuating object is detected.

Further topics

- [see "Fault indicators", page 21](#)

8.3 Adjustment

Adjusting distance

- ▶ Adjust the distance between the safety switch and actuating element so that the actuating object is reliably detected within assured switch-off distance S_{ao} (LED STATE permanently green).

Complementary information



NOTE

For variants with cylindrical housing, the distance can be adjusted by rotating the safety switch in or out.

9 Troubleshooting

9.1 Safety



DANGER

Hazard due to lack of effectiveness of the protective device

In the case of non-compliance, it is possible that the dangerous state of the machine may not be stopped or not stopped in a timely manner.

- ▶ Immediately shut the machine down if the behavior of the machine cannot be clearly identified.
- ▶ If a machine fault cannot be definitively determined or safely rectified, immediately shut the machine down.
- ▶ Secure the machine so that it cannot switch on unintentionally.



NOTE

Additional information on troubleshooting can be found at the responsible SICK subsidiary.

9.2 Fault indicators

Table 9: Fault indicators

LED STATE		Possible cause	Corrective measure
Green	Red		
○	○	No supply voltage	<ul style="list-style-type: none"> • Switch on the supply voltage.
○	● (4 Hz)	Internal error	<ul style="list-style-type: none"> • Switch the voltage supply off and on. • If the error occurs again, the sensor is defective. Replace sensor.
		Supply voltage too high or too low	<ul style="list-style-type: none"> • Check the supply voltage.
○	● (1 Hz)	External error	<ul style="list-style-type: none"> • Check wiring for cross-circuit and short-circuit. • Switch the voltage supply off and on. • If the error occurs again, the sensor is defective. Replace sensor.

10 Maintenance

10.1 Cleaning



NOTICE

- ▶ Do not use aggressive cleaning agents (such as isopropanol or spirit).
 - ▶ Do not use any substances that hinder the wetting properties of lacquers.
 - ▶ We recommend anti-static cleaning agents.
-

11 Decommissioning

11.1 Disposal

Approach

- ▶ Always dispose of unusable devices in accordance with national waste disposal regulations.



Complementary information

SICK will be glad to help you dispose of these devices on request.

12 Technical data

12.1 Data sheet

Table 10: Safety-related parameters

Safety-related parameters	
Performance level	PL d (EN ISO 13849-1:2015)
Category	Category 2 (EN ISO 13849-1:2015)
Safety integrity level	SIL 2 (IEC 61508)
SIL claim limit	SILCL 2 (IEC 62061)
PFHd (mean probability of a dangerous failure per hour)	
For operating heights ≤ 1,000 m above sea level	6×10^{-8} at 40 °C
For operating heights 1,001 m ... 2,000 m above sea level	7×10^{-8} at 40 °C
For operating heights 2,001... 3,000 m above sea level	8×10^{-8} at 40 °C
T _M (mission time)	20 years (EN ISO 13849-1:2015)
Type	Type 3 (ISO 14119)
Actuator coding level	Uncoded (EN ISO 14119)
Safe status when a fault occurs	At least one safety-related semiconductor output (OSSD) is in the OFF state.

Table 11: Features

Features	
Assured switch-on distance S _{ao} ¹⁾	
IS-IME2S-12	3.2 mm
Assured switch off distance S _{ar} ¹⁾	
IS-IME2S-12	6 mm
Sensing range S _n ¹⁾	
IS-IME2S-12	4 mm
Actuating frequency	≤ 100 Hz

¹⁾ Specified values apply to steel (FE360). A correction factor must be used for other materials [see table 4](#).

Table 12: Correction factor for sensing ranges S_{ao}, S_{ar} and S_n

Material	Correction factor
Mu-metal	1.2
Molded metal	1.1
Structural steel (Fe 360)	1.0
Rust-free steel (V2A, 304)	0.8
Aluminum	0.45
Copper	0.3
Brass	0.4

Table 13: Interfaces

Interfaces	
System connection (voltage supply and local outputs)	
IS-IME2S-12	M12 male connector, 4-pin

Table 14: Electrical data

Electrical data	
Protection class	III (EN 61140/IEC 61140)
Supply voltage V_S	DC 24 V (19.2 V DC ... 28.8 V DC)
Residual ripple	$\pm 10\%$ ¹⁾
Rated insulation voltage U_i	28.8 V
Voltage drop (of supply voltage)	≤ 3 V ²⁾
Contamination degree	3 (external, according to EN 60947-1)
Rated impulse withstand voltage U_{imp}	1,500 V
Utilization category (IEC 60947-5-1)	DC-12: 24 V / 20 mA
Device fuse	1 A
Current consumption at 24 V	< 20 mA
Hysteresis	$\leq 15\%$ of S_n
Repeatability	2%
Power-up delay (after supply voltage applied) ³⁾	< 1 s
Response time (removal from response range)	< 1 ms
Release time (response time when approaching response range)	
IS-IME2S-12	< 1 ms
Risk time ⁴⁾	< 20 ms

1) Within the limits of U_v .

2) AT 50 mA at each OSSD channel

3) Once the supply voltage has been switched on, the OSSDs are in the OFF state during the time delay before availability.

4) The risk time is the time needed to detect internal and external faults. External errors affect the OSSDs (short-circuit to an OSSD and cross-circuit between the two OSSDs). At least one of the two OSSDs is safely switched off during the risk time.

Table 15: Mechanical data

Dimensions	see "Dimensional drawings", page 26
Material IME2S	
Housing	Nickel plated brass
Sensor surface	VistaI®
Cable	PVC
Fixing nuts	Brass alloy
Tightening torque for mounting	
IME2S	12 Nm
Weight	see "Table of weights", page 26

Table 16: Outputs

Outputs	
Switching outputs	2 PNP semiconductors
Switching voltage	

Outputs	
ON state	19.2 V DC ... 28.8 V DC
OFF state	0 V DC ... 2 V DC
Switching current	
ON state	≤ 50 mA
OFF state	< 500 µA
Load capacity	80 nF
Short-circuit protection	Yes
Reverse polarity protection	Yes
Test pulse width	300 µs

Table 17: Ambient data

Ambient data	
Enclosure rating	IP 67 (IEC 60529) ¹⁾
Ambient operating temperature	-25 °C ... +70 °C
Temperature change rate	≤ 1 °K/min
Storage temperature	-25 °C ... +70 °C
Area of application (IEC 60654-1)	Class C; weather-protected area of application
Operating altitude	≤ 3,000 m above sea level
Relative humidity	50% at 70 °C (IEC 60947-5-2)
Vibration resistance	1 mm / 10 Hz ... 55 Hz (IEC 60947-5-2)
Shock resistance	In accordance with IEC 60947-5-2
EMC	In accordance with IEC 60947-5-2, IEC 60947-5-3 and IEC 61000-6-7
Minimum distance between 2 safety switches	see "Mounting", page 16

1) The adhesive strip above the LED displays must not be removed in order to achieve the specified enclosure rating.

12.2 Table of weights

Table 18: Weight IME2S

Type	Weight in g
IS-IME2S-12	18

12.3 Dimensional drawings

IME2S12

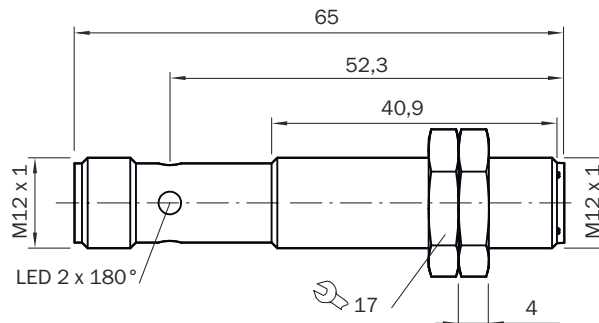

Figure 9: Dimensional drawing IS-IME2S-12

13 Annex

13.1 Compliance with EU directives

EU declaration of conformity (extract)

The undersigned, representing the manufacturer, herewith declares that the product is in conformity with the provisions of the following EU directive(s) (including all applicable amendments), and that the standards and/or technical specifications stated in the EU declaration of conformity have been used as a basis for this.

Complete EU declaration of conformity for download

You can call up the EU declaration of conformity and the current operating instructions for the protective device by entering the part number in the search field at www.sick.com (part number: see the type label entry in the "Ident. no." field).

Australia

Phone +61 (3) 9457 0600
1800 33 48 02 – tollfree
E-Mail sales@sick.com.au

Austria

Phone +43 (0) 2236 62288-0
E-Mail office@sick.at

Belgium/Luxembourg

Phone +32 (0) 2 466 55 66
E-Mail info@sick.be

Brazil

Phone +55 11 3215-4900
E-Mail comercial@sick.com.br

Canada

Phone +1 905.771.1444
E-Mail cs.canada@sick.com

Czech Republic

Phone +420 234 719 500
E-Mail sick@sick.cz

Chile

Phone +56 (2) 2274 7430
E-Mail chile@sick.com

China

Phone +86 20 2882 3600
E-Mail info.china@sick.net.cn

Denmark

Phone +45 45 82 64 00
E-Mail sick@sick.dk

Finland

Phone +358-9-25 15 800
E-Mail sick@sick.fi

France

Phone +33 1 64 62 35 00
E-Mail info@sick.fr

Germany

Phone +49 (0) 2 11 53 010
E-Mail info@sick.de

Greece

Phone +30 210 6825100
E-Mail office@sick.com.gr

Hong Kong

Phone +852 2153 6300
E-Mail ghk@sick.com.hk

Hungary

Phone +36 1 371 2680
E-Mail ertekezes@sick.hu

India

Phone +91-22-6119 8900
E-Mail info@sick-india.com

Israel

Phone +972 97110 11
E-Mail info@sick-sensors.com

Italy

Phone +39 02 27 43 41
E-Mail info@sick.it

Japan

Phone +81 3 5309 2112
E-Mail support@sick.jp

Malaysia

Phone +603-8080 7425
E-Mail enquiry.my@sick.com

Mexico

Phone +52 (472) 748 9451
E-Mail mexico@sick.com

Netherlands

Phone +31 (0) 30 229 25 44
E-Mail info@sick.nl

New Zealand

Phone +64 9 415 0459
0800 222 278 – tollfree
E-Mail sales@sick.co.nz

Norway

Phone +47 67 81 50 00
E-Mail sick@sick.no

Poland

Phone +48 22 539 41 00
E-Mail info@sick.pl

Romania

Phone +40 356-17 11 20
E-Mail office@sick.ro

Russia

Phone +7 495 283 09 90
E-Mail info@sick.ru

Singapore

Phone +65 6744 3732
E-Mail sales.gsg@sick.com

Slovakia

Phone +421 482 901 201
E-Mail mail@sick-sk.sk

Slovenia

Phone +386 591 78849
E-Mail office@sick.si

South Africa

Phone +27 10 060 0550
E-Mail info@sickautomation.co.za

South Korea

Phone +82 2 786 6321/4
E-Mail infokorea@sick.com

Spain

Phone +34 93 480 31 00
E-Mail info@sick.es

Sweden

Phone +46 10 110 10 00
E-Mail info@sick.se

Switzerland

Phone +41 41 619 29 39
E-Mail contact@sick.ch

Taiwan

Phone +886-2-2375-6288
E-Mail sales@sick.com.tw

Thailand

Phone +66 2 645 0009
E-Mail marcom.th@sick.com

Turkey

Phone +90 (216) 528 50 00
E-Mail info@sick.com.tr

United Arab Emirates

Phone +971 (0) 4 88 65 878
E-Mail contact@sick.ae

United Kingdom

Phone +44 (0)17278 31121
E-Mail info@sick.co.uk

USA

Phone +1 800.325.7425
E-Mail info@sick.com

Vietnam

Phone +65 6744 3732
E-Mail sales.gsg@sick.com

Detailed addresses and further locations at www.sick.com

