

# MPS-G with 2/3 switching points and IO-Link (up to 8 switching points)

Magnetic cylinder sensors

**SICK**  
Sensor Intelligence.



---

**Described product**

MPS-G

**Manufacturer**

SICK AG  
Erwin-Sick-Str. 1  
79183 Waldkirch  
Germany

**Legal information**

This work is protected by copyright. Any rights derived from the copyright shall be reserved for SICK AG. Reproduction of this document or parts of this document is only permissible within the limits of the legal determination of Copyright Law. Any modification, abridgment or translation of this document is prohibited without the express written permission of SICK AG.

The trademarks stated in this document are the property of their respective owner.

© SICK AG. All rights reserved.

**Original document**

This document is an original document of SICK AG.



## Contents

<b>1</b>	<b>About this document.....</b>	<b>5</b>
1.1	Further information.....	5
1.2	Symbols and document conventions.....	5
<b>2</b>	<b>Safety information.....</b>	<b>6</b>
2.1	Intended use.....	6
2.2	Improper use.....	6
2.3	Limitation of liability.....	6
2.4	Requirements for skilled persons and operating personnel.....	6
2.5	Hazard warnings and operational safety.....	7
2.6	Notes on UL approval.....	7
<b>3</b>	<b>Product description.....</b>	<b>8</b>
3.1	Product ID.....	8
3.1.1	Device view.....	8
3.2	Product characteristics.....	8
3.2.1	Product features.....	8
3.3	Operating principle.....	9
3.3.1	Principle of operation.....	9
3.3.2	Detection range.....	10
3.3.3	Position output.....	10
3.3.4	Switching behavior after Manual Teach of up to 3 switching points.....	11
3.3.5	Switching behavior after Dynamic Teach of 2 switching points.....	12
3.3.6	Switching behavior after Dynamic Teach of 3 switching points.....	15
<b>4</b>	<b>Transport and storage.....</b>	<b>20</b>
4.1	Transport.....	20
4.2	Transport inspection.....	20
4.3	Storage.....	20
<b>5</b>	<b>Mounting.....</b>	<b>21</b>
5.1	Mounting requirements.....	21
5.2	Optional accessories.....	21
5.3	Mounting.....	21
<b>6</b>	<b>Electrical installation.....</b>	<b>22</b>
6.1	Safety.....	22
6.1.1	Notes on electrical installation.....	22
6.1.2	Wiring instructions.....	22
6.2	Connections.....	24
6.2.1	Pin assignment/Connection diagram + wire colors.....	24
6.3	Connecting the supply voltage.....	24

<b>7</b>	<b>Commissioning.....</b>	<b>26</b>
7.1	Overview of commissioning steps.....	26
7.2	Positioning on drive.....	26
7.3	Put the sensor into operation for the first time.....	26
<b>8</b>	<b>Operation.....</b>	<b>28</b>
8.1	General notes on operation.....	28
8.2	Operating and status indicators.....	28
8.2.1	Control element.....	28
8.2.2	Status indicators.....	28
8.3	Teach-in mode.....	29
8.3.1	Dynamic Teach-in.....	30
8.3.2	Manual teach-in.....	32
8.4	Operation via IO-Link.....	36
8.4.1	Process data structure.....	36
8.4.2	General functions.....	37
8.4.3	Configuration options via IO-Link.....	37
8.4.4	Actuator diagnostic functions.....	46
<b>9</b>	<b>Troubleshooting.....</b>	<b>49</b>
<b>10</b>	<b>Maintenance.....</b>	<b>50</b>
<b>11</b>	<b>Decommissioning.....</b>	<b>51</b>
11.1	Replace device.....	51
11.2	Disassembly and disposal.....	51
11.3	Returning devices.....	51
<b>12</b>	<b>Technical data.....</b>	<b>52</b>
12.1	Dimensional drawing.....	53
<b>13</b>	<b>Glossary.....</b>	<b>55</b>
<b>14</b>	<b>Annex.....</b>	<b>57</b>
14.1	Teach routine at a glance.....	57
14.2	Conformities and certificates.....	58

# 1 About this document

## 1.1 Further information

You can find the product page with further information under the **SICK Product ID** at: [pid.sick.com/{P/N}](https://pid.sick.com/{P/N}).

P/N corresponds to the part number of the product.

The following information is available depending on the product:

- Data sheets
- These publication in all available languages
- CAD files and dimensional drawings
- Certificates (e.g., declaration of conformity)
- Other publications
- Software
- Accessories

## 1.2 Symbols and document conventions

### Warnings and other notes

---



#### **DANGER**

Indicates a situation presenting imminent danger, which will lead to death or serious injuries if not prevented.

---



#### **WARNING**

Indicates a situation presenting possible danger, which may lead to death or serious injuries if not prevented.

---



#### **CAUTION**

Indicates a situation presenting possible danger, which may lead to moderate or minor injuries if not prevented.

---



#### **NOTICE**

Indicates a situation presenting possible danger, which may lead to property damage if not prevented.

---



#### **NOTE**

Highlights useful tips and recommendations as well as information for efficient and trouble-free operation.

---

### Instructions to action

- ▶ The arrow denotes instructions to action.
- 1. The sequence of instructions is numbered.
- 2. Follow the order in which the numbered instructions are given.
- ✓ The tick denotes the results of an action.

## 2 Safety information

### 2.1 Intended use

The sensor from the MPS-G product family is an intelligent, magnetic position sensor. It is used for non-contact detection of the piston stroke of pneumatic drives with axially magnetized permanent magnets.

SICK AG assumes no liability for losses or damage arising from the use of the product, either directly or indirectly. This applies in particular to use of the product that does not conform to its intended purpose and is not described in this documentation.

### 2.2 Improper use

- The sensor does not constitute a safety-relevant device according to the EC Machinery Directive (2006/42/EC).
- The sensor must not be used in explosion-hazardous areas.
- Any other use that is not described as intended use is prohibited.
- Any use of accessories not specifically approved by SICK AG is at your own risk.
- The sensor is not suitable for outdoor applications.



#### NOTICE

##### Danger due to improper use!

Any improper use can result in dangerous situations.

Therefore, take note of the following information:

- ▶ The sensor should be used only in line with intended use specifications.
  - ▶ All information in these operating instructions must be strictly complied with.
- 

### 2.3 Limitation of liability

Applicable standards and regulations, the latest state of technological development, and our many years of knowledge and experience have all been taken into account when assembling the data and information contained in these operating instructions. The manufacturer accepts no liability for damage caused by:

- Failing to observe the operating instructions
- Improper use
- Use by untrained personnel
- Unauthorized conversions
- Technical modifications
- Use of unauthorized spare parts, consumables, and accessories

With special variants, where optional extras have been ordered, or owing to the latest technical changes, the actual scope of delivery may vary from the features and illustrations shown here.

### 2.4 Requirements for skilled persons and operating personnel



#### WARNING

##### Risk of injury due to insufficient training.

Improper handling of the sensor may result in considerable personal injury and material damage.

- All work must only ever be carried out by the stipulated persons.
-

The operating instructions state the following qualification requirements for the various areas of work:

- **Instructed personnel** have been briefed by the operating entity about the tasks assigned to them and about potential dangers arising from improper action.
- **Skilled personnel** have the specialist training, skills, and experience, as well as knowledge of the relevant regulations, to be able to perform tasks assigned to them and to detect and avoid any potential dangers independently.
- **Electricians** have the specialist training, skills, and experience, as well as knowledge of the relevant standards and provisions to be able to carry out work on electrical systems and to detect and avoid any potential dangers independently. In Germany, electricians must meet the specifications of the BGV A3 Work Safety Regulations (e.g., Master Electrician). Other relevant regulations applicable in other countries must be observed.

The following qualifications are required for various activities:

Activities	Qualification
Mounting, maintenance	<ul style="list-style-type: none"> <li>■ Basic practical technical training</li> <li>■ Knowledge of the current safety regulations in the workplace</li> </ul>
Electrical installation, device replacement	<ul style="list-style-type: none"> <li>■ Practical electrical training</li> <li>■ Knowledge of current electrical safety regulations</li> <li>■ Knowledge of the operation and control of the devices in their particular application</li> </ul>
Commissioning, configuration	<ul style="list-style-type: none"> <li>■ Basic knowledge of the design and setup of the described connections and interfaces</li> <li>■ Basic knowledge of data transmission</li> <li>■ Knowledge of the operation and control of the devices in their particular application</li> </ul>
Operation of the devices in their particular application	<ul style="list-style-type: none"> <li>■ Knowledge of the operation and control of the devices in their particular application</li> <li>■ Knowledge of the software and hardware environment in the application</li> </ul>

## 2.5 Hazard warnings and operational safety

Please observe the safety notes and the warnings listed here and in other chapters of these operating instructions to reduce the possibility of risks to health and avoid dangerous situations.

## 2.6 Notes on UL approval

The device must be supplied by a Class 2 source of supply.

UL Environmental Rating: Enclosure type 1

### 3 Product description

#### 3.1 Product ID

##### 3.1.1 Device view

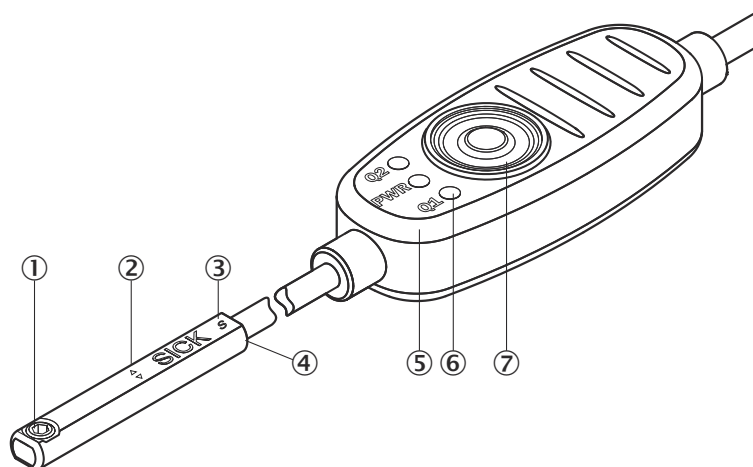

Figure 1: Operating elements and status indicators

- ① Fixing screw, size 1.3 (Tightening torque  $M_A = 0.1 \text{ Nm}$ )
- ② Physical zero position
- ③ Cylinder type marking  
(S = SMC/BIMBA/Schunk/PHD; F = FESTO/ZIMMER)
- ④ Sensor head
- ⑤ Operating element
- ⑥ 3 x LED indicators
- ⑦ Teach-in button

#### 3.2 Product characteristics

##### 3.2.1 Product features

The MPS-G with 2 / 3 digital switching points and IO-Link (up to 8 switching points) is used either as a magnetic cylinder sensor for non-contact detection of 2 end positions or intermediate positions (up to 3 individually adjustable switching points in one housing) or via IO-Link as a position sensor for non-contact linear position measurement mainly in pneumatic cylinders, grippers and slides.

When using IO-Link, up to 8 switching points can also be set and additional actuator diagnostic data can be recorded and output.

- Stroke traveled
- Cycle time
- Dwell time of the piston
- Travel time of the piston
- Average piston velocity
- Current measured field strength
- Maximum measured field strength
- Cycle count
- Total distance traveled by the piston
- Operating hours
- Power-on/power-off cycles



A description of the diagnostic functions can be found in [section 8.4.4](#).

**Target application**

- Double end position detection via 2 digital switching points  
→ Substitute for two individual cylinder switches
- Detection of 3 positions via 3 digital switching points, e.g. for gripper process (open without object / object gripped / closed without object)  
→ Substitute for three individual cylinder switches
- Position measurement for short stroke in systems with IO-Link
- Detection of 8 positions via 8 switching points, e.g. for gripper process (gripping of objects of different sizes)

**Mechanical standard variants**

The mechanical standard variants differ in the geometry of the sensor head, the length of the connection cable between the head and control panel, the length of the connecting cable between the control panel and connection and in the connection.



Figure 2: MPS-G structure

- ① Sensor head:  
Festo slot (F)  
SMC slot (S)
- ② Head / Control panel connection cable
- ③ Sensor connecting cable
- ④ Sensor connection

Table 1: Mechanical variants

Part number	Type designation	Sensor head	Connection cable	Functional scope (output)	Connecting cable
1127842	MPS-G50 ...	F	0.1 m	2/3Q and IO-Link	0.5 m, M8 knurled screw
1127843	MPS-G50 ...	S	0.1 m	2/3Q and IO-Link	0.5 m, M8 knurled screw
1127844	MPS-G50 ...	S	0.5 m	2/3Q and IO-Link	0.5 m, M8 knurled screw
1127845	MPS-G50 ...	F	0.1 m	2/3Q and IO-Link	0.3 m, M12
1127846	MPS-G50 ...	S	0.1 m	2/3Q and IO-Link	0.3 m, M12
1127847	MPS-G50 ...	S	0.5 m	2/3Q and IO-Link	0.3 m, M12

**3.3 Operating principle**

**3.3.1 Principle of operation**

The MPS-G determines the position of an encoder magnet via a row of 2 sensor elements located in the sensor head.

Axially and diametrically magnetized magnets can be detected since the two sensor elements measure the field strength in both the X- and Y-direction.

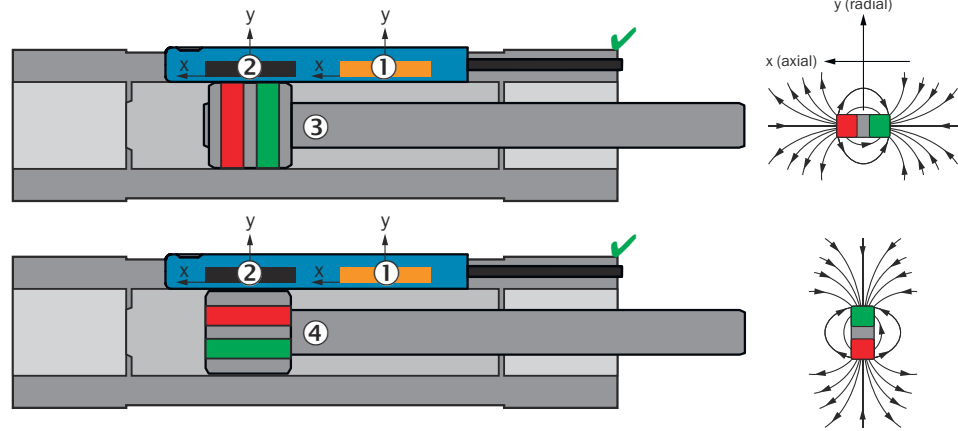

- ① Sensor element 1
- ② Sensor element 2
- ③ Axially magnetized magnet
- ④ Diametrically magnetized magnet

#### 3.3.2 Detection range

The sensor is designed for a detection range of 50 mm. The zero point / physical zero position is marked with arrows on the sensor head and is located roughly at the center point of the sensor. From the zero point, -25 mm are measured to the cable and +25 mm to the fixing screw.

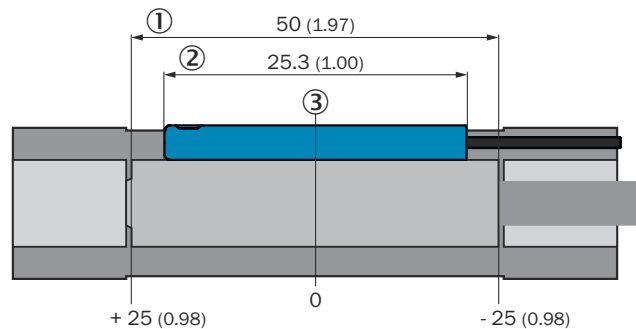

Figure 3: Detection range

- ① Detection range
- ② Housing length
- ③ Zero point / physical zero position

#### 3.3.3 Position output

The sensor can output a linearized position in a detection range of approx. 50 mm (depends on the drive).

Via IO-Link, the detection range of 50 mm (-25 mm ... 25 mm) corresponds to 5,000 digits (-2,500 digits ... 2,500 digits). I.e. 1 digit corresponds to 10  $\mu$ m.

When leaving the detection range, the value 32,760 or -32,760 digits<sup>1)</sup> is displayed.

If the field strength is no longer sufficient, 32764 is output as per the Smart Sensor profile.

1) 1 digit corresponds to 10  $\mu$ m.

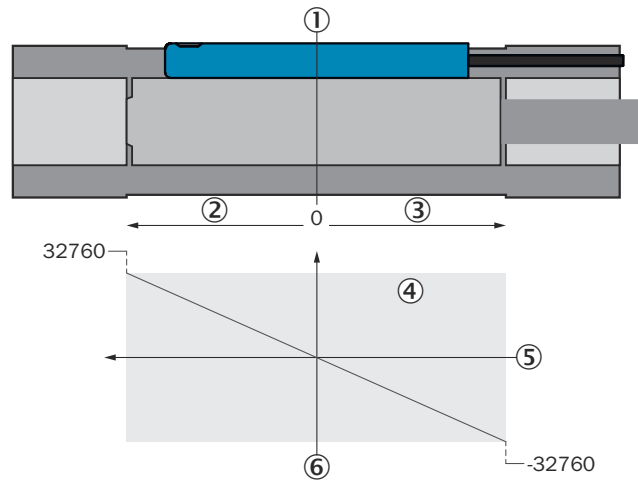

Figure 4: Zero point / physical zero position

- ① Zero point / physical zero position
- ② Positive positions
- ③ Negative positions
- ④ Sensor detection range: 2,500 digits ... -2,500 digits
- ⑤ Piston position
- ⑥ Sensor position output

### 3.3.4 Switching behavior after Manual Teach of up to 3 switching points

Switching behavior after **Manual Teach** is as follows per switching point during operation:

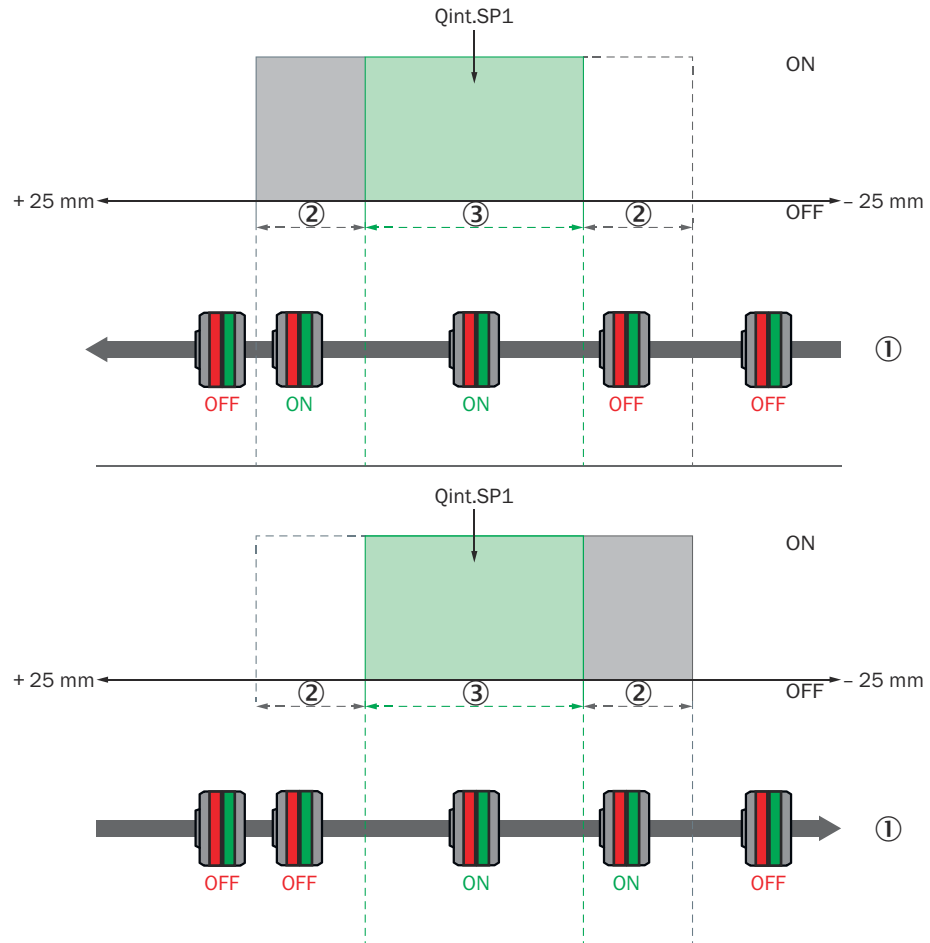

Figure 5: Switching behavior after **Manual Teach**

- ① Direction of movement of the magnet
- ② Hysteresis
- ③ Width of the switching point

There is no **Dynamic Pilot** during manual teach-in of the switching points. The switching point width is 2 mm according to the factory setting and can be adjusted via the Teach menu (1 – 5 mm).

### 3.3.5 Switching behavior after Dynamic Teach of 2 switching points

If the sensor, during Dynamic Teach, detects teach 2 x piston status  $v = 0$ , 2 switching points are set.



**NOTE**

The dynamic teach-in and the **dynamic pilot** only start working from a speed of  $v > 0.025$  m/s.

**Example: Arrangement of switching points for dynamic teach-in of 2 switching points on a pneumatic cylinder**

The 2 switching points are always arranged as follows during dynamic teach-in: Qint1 lies in the direction of the cable connection and Qint2 in the direction of the sensor fixing screw. It does not matter which position is approached first.

Table 2: Switching behavior with 2 switching points

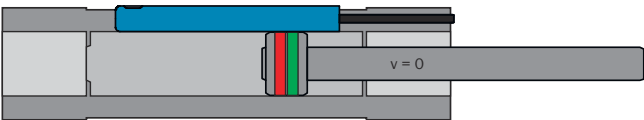
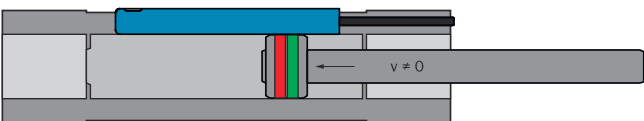
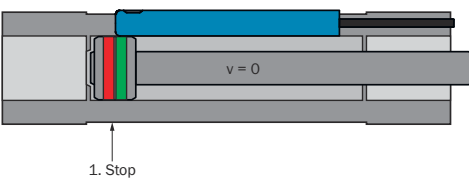
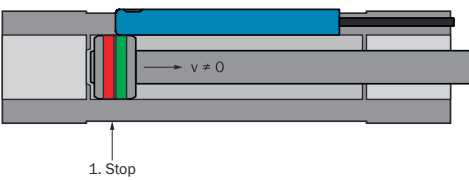
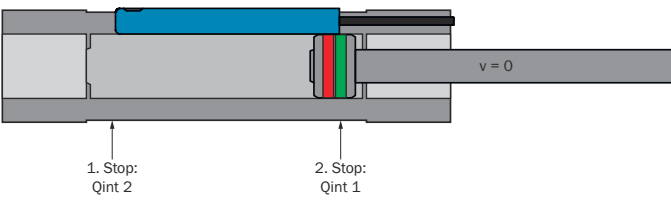
<p>1.) Output position <math>v = 0</math>. No switching point is defined at the output position of the magnet.</p>	
<p>2.) Movement in the direction of the sensor fixing screw</p>	
<p>3.) First stop: First position is defined for switching point</p>	
<p>4.) Movement in the direction of the cable side</p>	
<p>5.) Second stop: Second position for switching point and arrangement of Qint2 (see fixing screw) and Qint1 (cable set) are defined</p>	

Switching behavior after **Dynamic Teach** of 2 switching points is the following during operation:

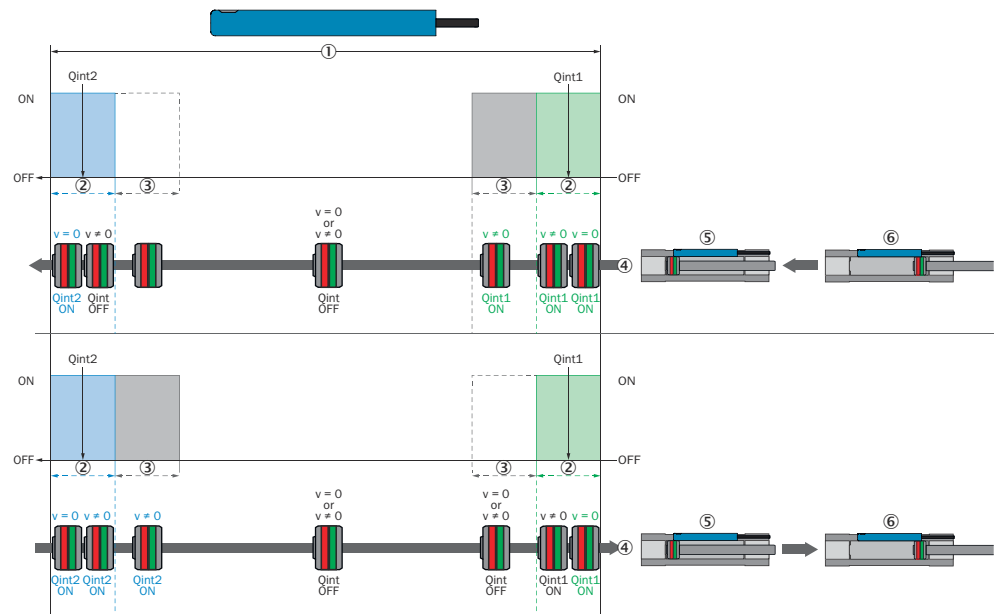

Figure 6: Overview

- ① Max. range of movement of drive
- ② Tolerance
- ③ Hysteresis
- ④ Direction of movement of the magnet
- ⑤ End position in the direction of the fixing screw
- ⑥ End position in the direction of the cable connection

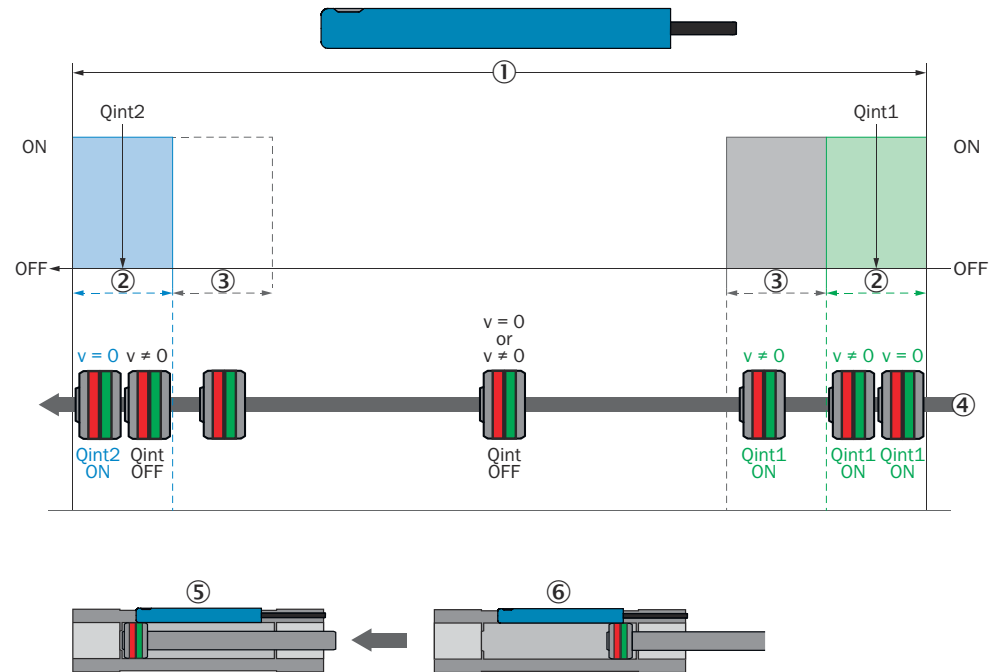

Figure 7: Movement in the direction of the fixing screw

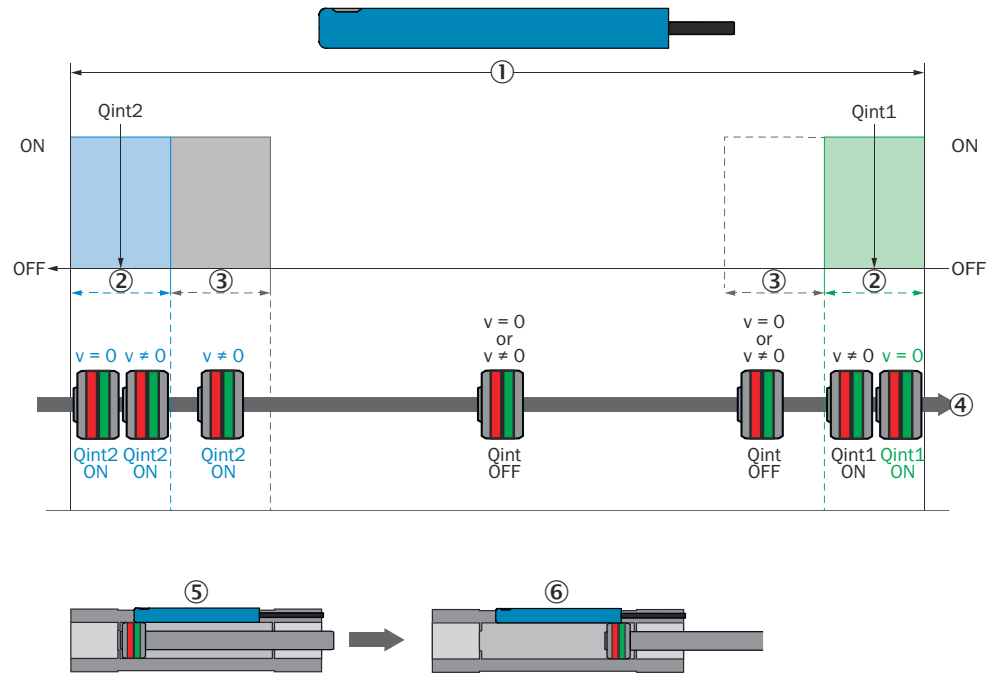

Figure 8: Movement in the direction of the cable connection

### 3.3.6 Switching behavior after Dynamic Teach of 3 switching points

If the sensor, during Dynamic Teach, detects teach 3 x piston status  $v = 0$ , 3 switching points are set.

**Example: Arrangement of switching points for dynamic teach-in of 3 switching points on a pneumatic internal or external gripper**

The switching points are assigned as follows:

Qint1 = idle

Qint2 = object

Qint3 = noobject

The assignment of the idle and no object states to gripper open or gripper closed depends on the gripper type:

#### 1. External gripper:

Table 3: External gripper

Gripper open without object idle	Gripper closed with object object	Gripper open without object idle	Gripper closed without object noobject	Gripper open without object idle

No switching point is defined on the output position of the magnet	First position is defined for switching point	Second position is defined for switching point	Third position is defined for switching point	Switching points are assigned to the positions
--	---	--	---	--

After the teach-in process, the Qints are assigned as follows:

- Qint1 gripper open without object (idle)
- Qint2 gripper closed with object (object)
- Qint3 gripper closed without object (noobject)

#### 2. Internal gripper:

Table 4: Internal gripper

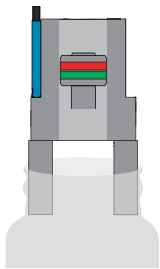
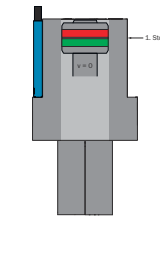
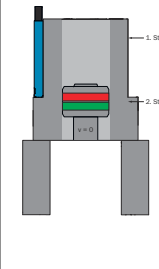
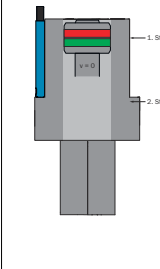
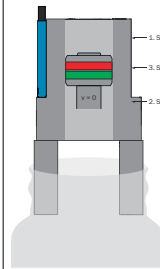
Gripper open with object	Gripper closed without object idle	Gripper open without object noobject	Gripper closed without object idle	Gripper open with object object
				
No switching point is defined on the output position of the magnet	First position is defined for switching point	Second position is defined for switching point	First position is already defined and is not saved again	Third position is defined for switching point.

After the teach-in process, the Qints are assigned as follows:

- Qint1 gripper closed without object (idle)
- Qint2 gripper open with object (object)
- Qint3 gripper open without object (noobject)

Switching behavior after **Dynamic Teach** of 3 switching points is the following during operation:



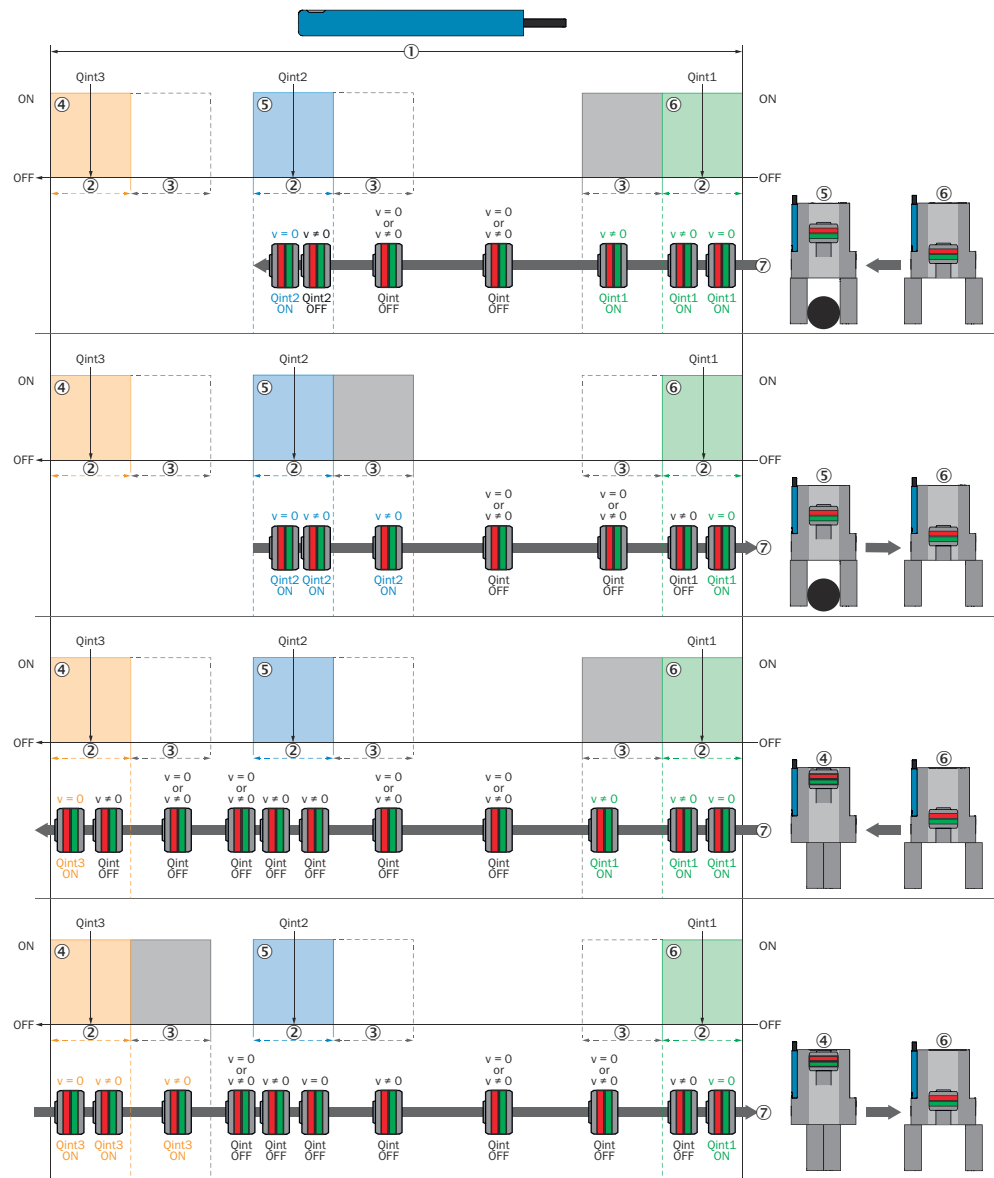

Figure 9: Overview

- ① Max. range of movement of drive
- ② Tolerance
- ③ Hysteresis
- ④ no object
- ⑤ object
- ⑥ idle
- ⑦ Direction of movement of the magnet

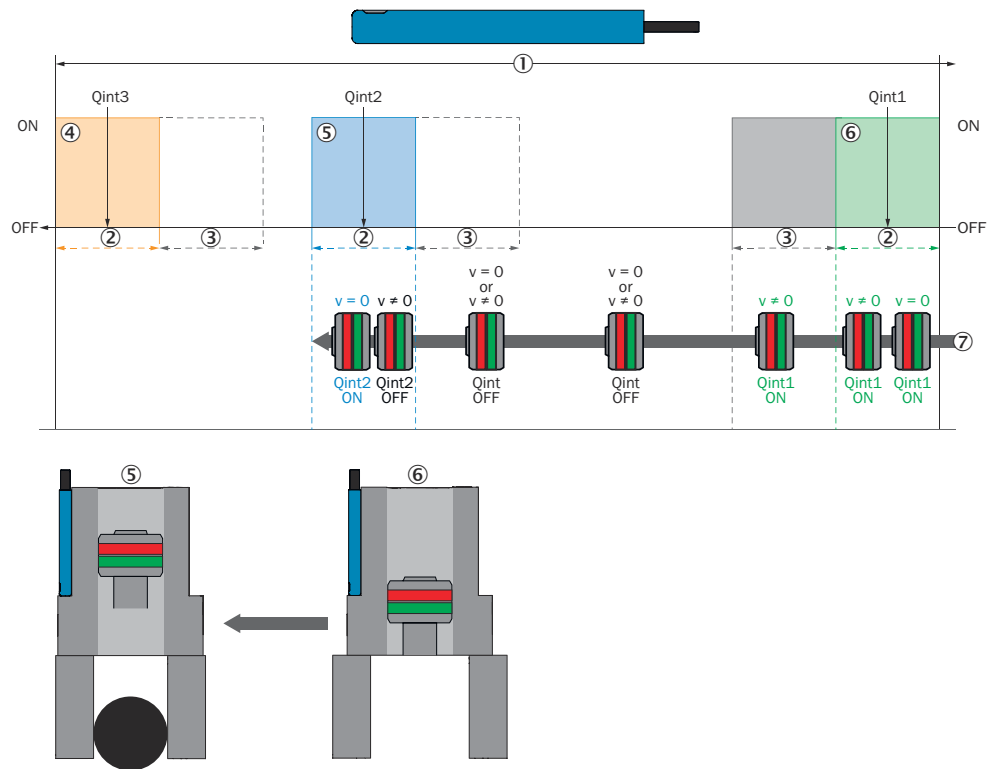

Figure 10: Movement from idle to object

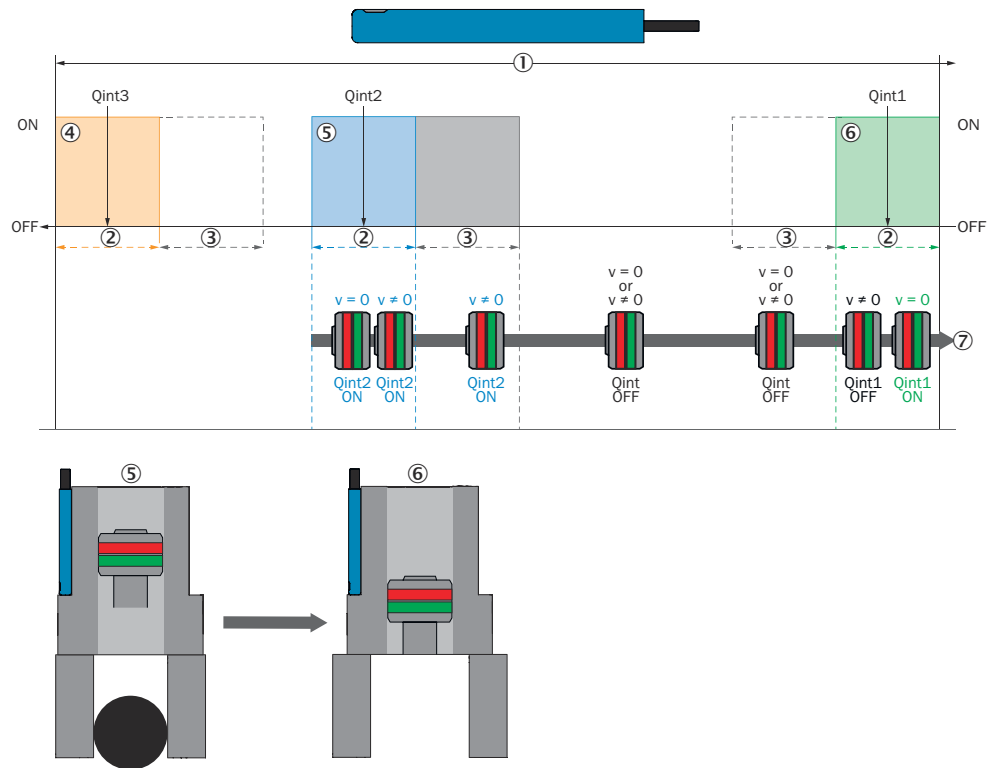

Figure 11: Movement from object to idle

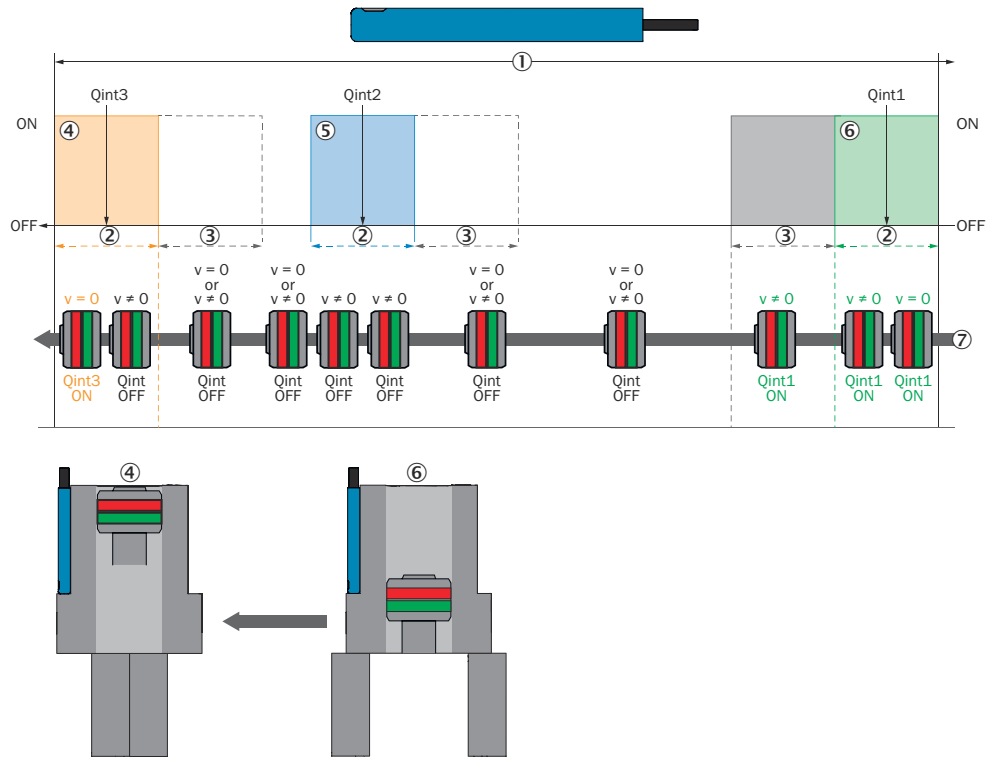

Figure 12: Movement from idle to no object

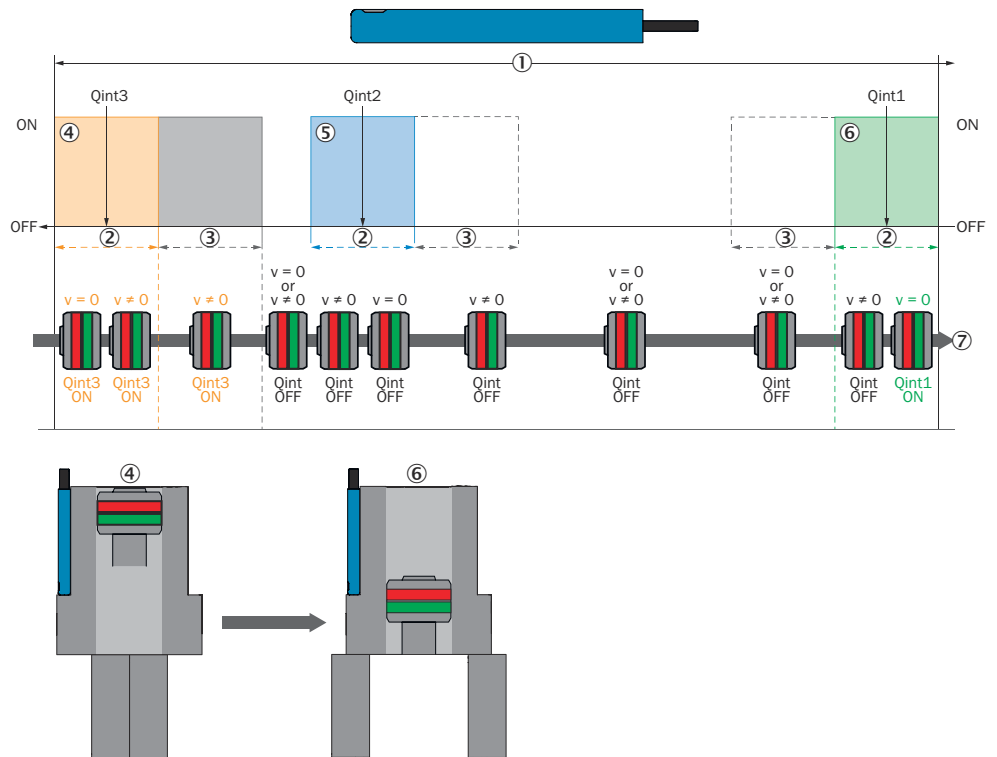

Figure 13: Movement from no object to idle

### 4 Transport and storage

#### 4.1 Transport

For your own safety, please read and observe the following notes:



##### NOTE

##### Damage to the sensor due to improper transport.

- The device must be packaged for transport with protection against shock and damp.
- Transport should be performed by specialist staff only.
- The utmost care and attention is required at all times during unloading and transportation on company premises.
- Note the symbols on the packaging.
- Do not remove packaging until immediately before you start mounting.

#### 4.2 Transport inspection

Immediately upon receipt at the receiving work station, check the delivery for completeness and for any damage that may have occurred in transit. In the case of transit damage that is visible externally, proceed as follows:

- Do not accept the delivery or only do so conditionally.
- Note the scope of damage on the transport documents or on the transport company's delivery note.
- File a complaint.



##### NOTE

Complaints regarding defects should be filed as soon as these are detected. Damage claims are only valid before the applicable complaint deadlines.

#### 4.3 Storage

Store the device under the following conditions:

- Recommendation: Use the original packaging.
- Do not store outdoors.
- Store in a dry area that is protected from dust.
- To allow any residual dampness to evaporate, do not package in airtight containers.
- Do not expose to any aggressive substances.
- Protect from sunlight.
- Avoid mechanical shocks.
- Storage temperature: see "Technical data", page 52.
- Relative humidity see "Technical data", page 52.
- Do not expose to strong magnetic fields.

## 5 Mounting

### 5.1 Mounting requirements

- Comply with technical data such as the permitted ambient conditions for operation of the sensor (e.g., temperature range, EM interference), see "technical data", page 52.
- Protect the sensor from direct sunlight.
- Only mount sensor with the intended accessories.

#### Mounting location

When selecting the mounting location, the following factors must be considered:

- The mounting location must be as free from (electro)magnetic disturbance fields as possible

### 5.2 Optional accessories

Table 5: Optional accessories

Part number	Designation
2117133	Control panel mounting
2117770	T-slot adapter

### 5.3 Mounting

Insert sensor into the slot from above. The PWR LED<sup>2)</sup> lights up green .

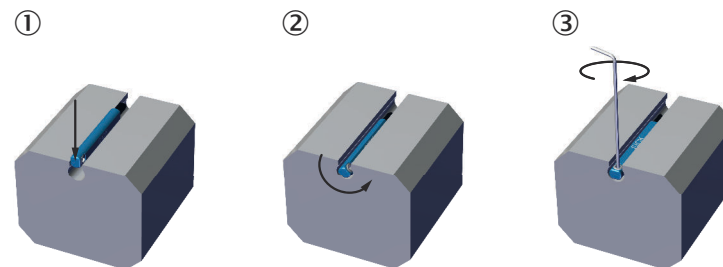

Figure 14: Installation steps

- ① Insert sensor
- ② Turn sensor
- ③ Tighten screws (tightening torque max. 0.1 Nm)



#### NOTE

When tightening the screw, use a non-magnetic Allen key.

2) PWR LED = Power LED

### 6 Electrical installation

#### 6.1 Safety

##### 6.1.1 Notes on electrical installation

---



#### CAUTION

##### Danger due to incorrect supply voltage!

An incorrect supply voltage may result in injuries from electric shocks and/or damage to the device.

- Only operate the sensor with safety/protective extra-low voltage (SELV/PELV).
- 



#### NOTICE

##### Sensor damage or unpredictable operation due to working with live parts.

Working with live parts may result in unpredictable operation.

- Only carry out wiring work when the power is off.
  - Only connect and disconnect electrical connections when the power is off.
- 

- **The electrical installation must only be performed by electrically qualified personnel.**
- **Standard safety requirements must be observed when working on electrical systems!**
- Only switch on the supply voltage for the device when the connection tasks have been completed and the wiring has been thoroughly checked.
- When using extension cables with open ends, ensure that bare wire ends do not come into contact with each other (risk of short-circuit when supply voltage is switched on!). Wires must be appropriately insulated from each other.
- Wire cross-sections in the supply cable from the user's power system must be designed in accordance with the applicable standards. When this is being done in Germany, observe the following standards: DIN VDE 0100 (Part 430) and DIN VDE 0298 (Part 4) and/or DIN VDE 0891 (Part 1).
- Circuits connected to the device must be designed as SELV circuits (SELV = Safety Extra Low Voltage).
- Protect the device with a separate fuse at the start of the supply circuit.

The IP enclosure rating for the sensor is only achieved if the connected cable is completely screwed in.

##### 6.1.2 Wiring instructions

---



#### NOTE

Pre-assembled cables can be found online at:

- ▶ [www.sick.com/mps-g](http://www.sick.com/mps-g)
- 

Please observe the following wiring instructions:

- During installation, pay attention to the different cable groups. The cables are grouped into the following four groups according to their sensitivity to interference or radiated emissions:
  - Group 1: Cables very sensitive to interference, such as analog measuring cables
  - Group 2: Cables sensitive to interference, such as sensor cables, communication signals, bus signals

- Group 3: Cables which are a source of interference, such as control cables for inductive loads, motor brakes
- Group 4: Cables which are powerful sources of interference, such as output cables from frequency inverters, welding system power supplies, power cables
- ▶ Cables in groups 1, 2 and 3, 4 must be crossed at right angles, [see figure 15](#).
- ▶ Cables in groups 1, 2 and 3, 4 must be routed in different cable channels or metallic separators must be used, [see figure 16](#) and [see figure 17](#). This applies particularly where cables of devices with a high level of radiated emission, such as frequency converters, are laid parallel to sensor cables.

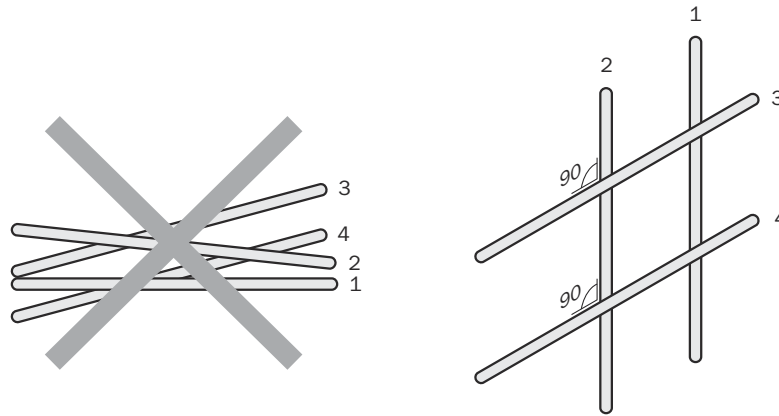

Figure 15: Cross cables at right angles

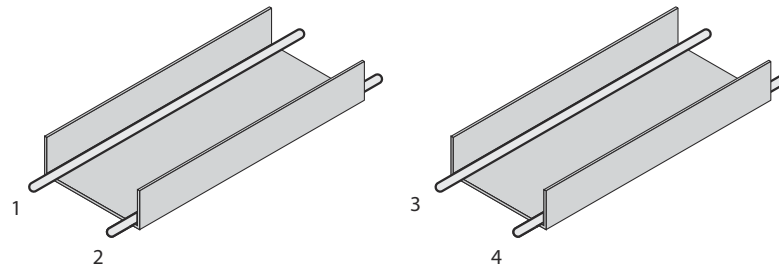

Figure 16: Ideal laying - Place cables in different cable channels

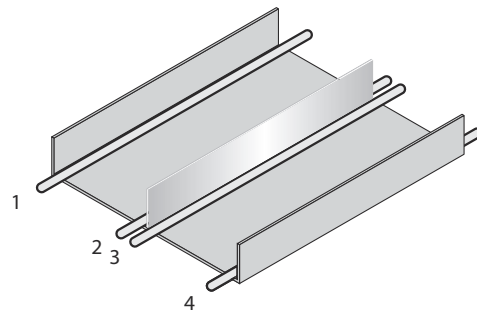

Figure 17: Alternative laying - Separate cables with metallic separators



#### NOTE

Prevent equipotential bonding currents via the cable shield with a suitable earthing method, [see "Safety", page 22](#).

## 6.2 Connections

### 6.2.1 Pin assignment/Connection diagram + wire colors

MPS-GxxxxxxxAXxxxxxxxxxxxxxxxxxxxx: Open cable end

Table 6: Pin assignment for male connector, M8, A-coded, 4-pin

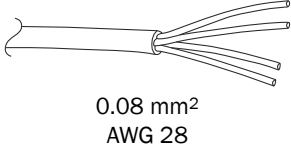
PIN	Connection	Pin assignment
1	BN	+ (L+)
2	WH	Q2
3	BU	- (M)
4	BK	Q1
 		

MPS-GxxxxxxxCXxxxxxxxxxxxxxxxxxxxx / MPS-GxxxxxxxDXxxxxxxxxxxxxxxxxxxxx: M8 connection

Table 7: Pin assignment for male connector, M8, A-coded, 4-pin

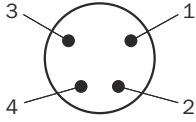
PIN	Connection	Pin assignment
1	BN	+ (L+)
2	WH	Q2
3	BU	- (M)
4	BK	Q1 / IO-Link
 		

MPS-GxxxxxxxEXxxxxxxxxxxxxxxxxxxxx: M12 connection

Table 8: Pin assignment for male connector, M12, A-coded, 4-pin

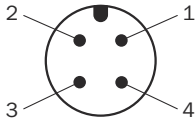
PIN	Connection	Pin assignment
1	BN	+ (L+)
2	WH	Q2
3	BU	- (M)
4	BK	Q1 / IO-Link
 		

## 6.3 Connecting the supply voltage

The sensor must be connected to a voltage supply with the following properties:

- Supply voltage DC 10 V ... 30 V (SELV/PELV as per currently valid standards)
- Electricity source with at least 5 W power

### Protecting the supply cables

To ensure protection against short-circuits/overload in the customer's supply cables, the wire cross-sections used must be appropriately selected and protected.



The following standards must be observed in Germany:

- DIN VDE 0100 (part 430)
- DIN VDE 0298 (part 4) and/or DIN VDE 0891 (part 1)

## 7 Commissioning

### 7.1 Overview of commissioning steps

- Connect the voltage supply.
- Commission the sensor using the factory settings.
- Configure the sensor.

### 7.2 Positioning on drive

To achieve the best possible performance, the sensor should be positioned centrally to the travel range of the magnet.

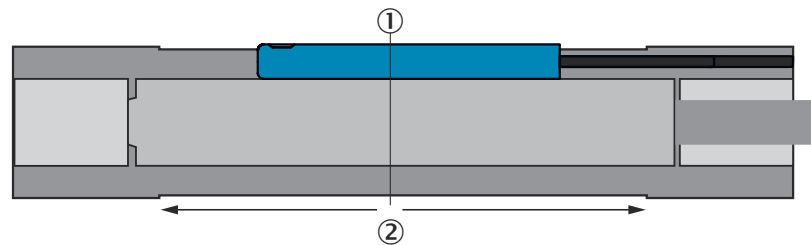

Figure 18: Positioning on drive

- ① Zero point
- ② Same distance in both directions

### 7.3 Put the sensor into operation for the first time

The sensor can optionally be operated with or without IO-Link.

#### IODD

If the sensor is operated via IO-Link, an associated IODD file with the appropriate version must be used. The IODD file can be downloaded at [www.sick.com/mps-g](http://www.sick.com/mps-g). The production date in the IODD file name must match the production date on the sensor or packaging.

#### Teach-in process

For optimal sensor performance, move the drive through the entire range of movement of the drive roughly 5x. Not until teach-in is complete is the complete accuracy (minimal linearity error, correct display of measuring range) achieved. If switching points are taught before teach-in is complete, these change their position during the teach-in process. The teach-in process can be accelerated by running an **Application Reset** or **Factory Reset** or **Reset trained algorithm parameter** via IO-Link after mounting the sensor. The sensor then only needs about two strokes to teach in the drive with sufficient accuracy. A detailed description of the Application Reset can be found in [section 8.4.3.3](#).

#### Application measuring range

Monotonicity violations can occur in the edge region of drives, which in turn lead to pseudo-position detections in the edge region. To prevent this, the maximum possible measuring range of the application (drive) is determined by the sensor. The criterion for the limits of the application measuring range is the repeatability determined by the sensor.

The application measuring range can be read via IO-Link using index 16512 (0x4080) **MDC Descr**, subindex 1 (0x01) **Lower Limit** and subindex 2 (0x02) **Upper Limit**. The application measuring range can be influenced via the index 265 **Position noise limit for application range [mm]**:

Smaller value → Smaller application measuring range, better performance

Larger value → Larger application measuring range, poorer performance

By default, the sensor maps a measuring range of 50 mm (from -25 mm to +25 mm).

## 8 Operation

### 8.1 General notes on operation

Teach-in can be performed using the teach-in button or IO-Link.



**NOTE**

The user is responsible for the correct teach-in procedure.

### 8.2 Operating and status indicators

#### 8.2.1 Control element



The following settings can be made via the teach-in button.

- Definition of up to 3 switching points (digital outputs) via **Dynamic Teach** function
- Manual definition of 1 to 3 switching points (digital outputs)
- Adjustment of overrun distance per switching point (1 – 5 mm) (after **Manual Teach**)
- Deactivation of all switching points

#### 8.2.2 Status indicators

3 LEDs are arranged on the control panel. The two outer LEDs light up yellow and the center LED in green.



The table below describes the individual function displays. The actual behavior of the LEDs during operation represents a combination of these function displays.

Table 9: Function of the LEDs

Sensor condition	LED 1 (Q1)		LED 2 (PWR)		LED 3 (Q2)	
	Display	Meaning	Display	Meaning	Display	Meaning
SIO <sup>1</sup>	● Lights up	Q1 high	● Lights up	Power ok	● Lights up	Q2 high
	○ Does not light up	Q1 low			○ Does not light up	Q2 low

Sensor condition	LED 1 (Q1)		LED 2 (PWR)		LED 3 (Q2)	
	Display	Meaning	Display	Meaning	Display	Meaning
IO-Link <sup>2</sup>	● Lights up	Q1 high	● Flashing	IO-Link active	● Lights up	Q2 high
	○ Does not light up	Q1 low			○ Does not light up	Q2 low
Error	No error display via LEDs					
Teach	This table only lists the LED behavior during operation. The LED behavior during teach-in can be found in <a href="#">section 8.3</a> .					
Locked state	In the locked state, LEDs 1 and 3 flash rapidly several times for 2 s when the pushbutton is pressed.					

<sup>1</sup> If LED 1 (Q1), LED 2 (PWR) and LED 3 (Q3) light up at the same time, Q3 is active.

- <sup>2</sup>
- During position measurement via IO-Link, only LED 2 (PWR) flashes
  - Up to 16 switching points can be taught in via IO-Link. Only the first 3 switching points are shown via LEDs as in SIO mode.

## 8.3 Teach-in mode

Table 10: Teach-in procedure

Teach-in mode	Dynamic Teach-in Automatic teach-in of the switching points		Manual Teach-in Manual teach-in of the switching points
Number of switching points	<b>2 switching points</b> When 2 x speed $v^1 = 0$ is detected during teach-in.	<b>3 switching points</b> When 3 x speed $v^1 = 0$ is detected during teach-in.	<b>3 switching points</b> Between 1 and 3 switching point (Qints) can be manually taught in independently of each other.
Are switching points (SP) taught in independently?	<b>NO</b> Depending on the requirement, 2 or 3 Qints can be taught in one process.		<b>YES</b> Up to 3 SP are taught in independently.
Is Dynamic Pilot active?	<b>YES</b> In <b>Dynamic Pilot</b> , there are 2 conditions for Qint during operation ON: The piston velocity must be $v = 0^1$ . The magnet must be within the tolerance band defined in <b>Dynamic Teach</b> and the direction of movement of the piston must correspond.		<b>NO</b> If the switching points are taught in manually, there is no <b>Dynamic Pilot</b> .
Arrangement of switching points	<b>Always the same</b> Qint1 lies in the direction of the cable outlet and Qint2 in the direction of the sensor fixing screw	<b>Depends</b> The switching points are assigned as follows: Qint1 = idle Qint2 = object Qint3 = noobject That is why the arrangement depends on whether an internal or external gripper is used.	<b>Free arrangement</b> The Qint1, Qint2 and Qint3 switching points can be freely set.

Teach-in mode	Dynamic Teach-in Automatic teach-in of the switching points		Manual Teach-in Manual teach-in of the switching points
Application	<b>End position detection:</b> Automated teach-in of 2 switching points via <b>Dynamic Teach</b> is intended for end position detection on a pneumatic cylinder.	<b>Gripper status detection:</b> The automated teach-in of 3 switching points via <b>Dynamic Teach</b> is intended for gripper status detection.	<b>Other applications:</b> If neither only the end positions on a pneumatic cylinder nor gripper statuses are to be taught in automatically, manually teaching switching points is recommended.
Measuring range	The <b>measuring range</b> of the sensor must cover the complete stroke.		The <b>measuring range</b> of the sensor must NOT cover the complete stroke.

<sup>1</sup> v = speed

For dynamic teach-in of 2 switching points via **Dynamic Teach**, it is assumed that the end positions of a piston should be detected in a pneumatic cylinder. If the 2 switching points are to be placed randomly within the measuring range, we recommend teaching in the 2 switching points manually via **Manual Teach**.

For dynamic teach-in of 3 switching points via **Dynamic Teach**, it is assumed that 3 statuses of a pneumatic gripper should be detected during the gripping process.

- Status 1 “idle”: Gripper open without object (external gripper) / Gripper closed without object (internal gripper)
- Status 2 “object”: Gripper closed without object (external gripper) / Gripper open with object (internal gripper)
- Status 3 “noobject”: Gripper closed without object (external gripper) / Gripper open without object (external gripper)

If the 3 switching points are to be placed randomly within the measuring range, we recommend teaching in 3 switching points manually via **Manual Teach**.

### 8.3.1 Dynamic Teach-in

**Dynamic Teach-in** is used to have the sensor automatically set the switching points.

The sensor detects the movement stops and then assigns the respective switching points to the found positions. (The positions must be at least 1 mm apart to be detected as two different positions).

The initial position of the piston when **Dynamic Teach-in** starts is NOT regarded as the first stop!



**NOTE**

The magnet must be moved at a speed greater than 0.025 m/s so the **Dynamic Teach-in** works correctly.

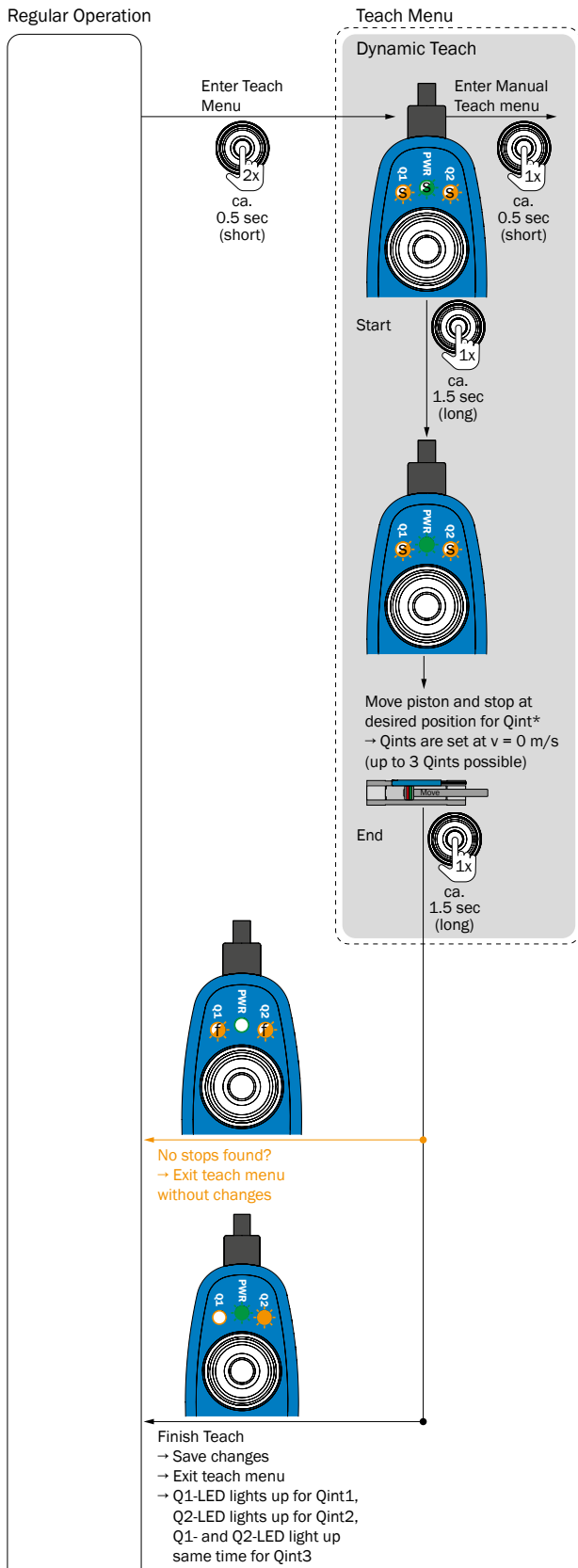

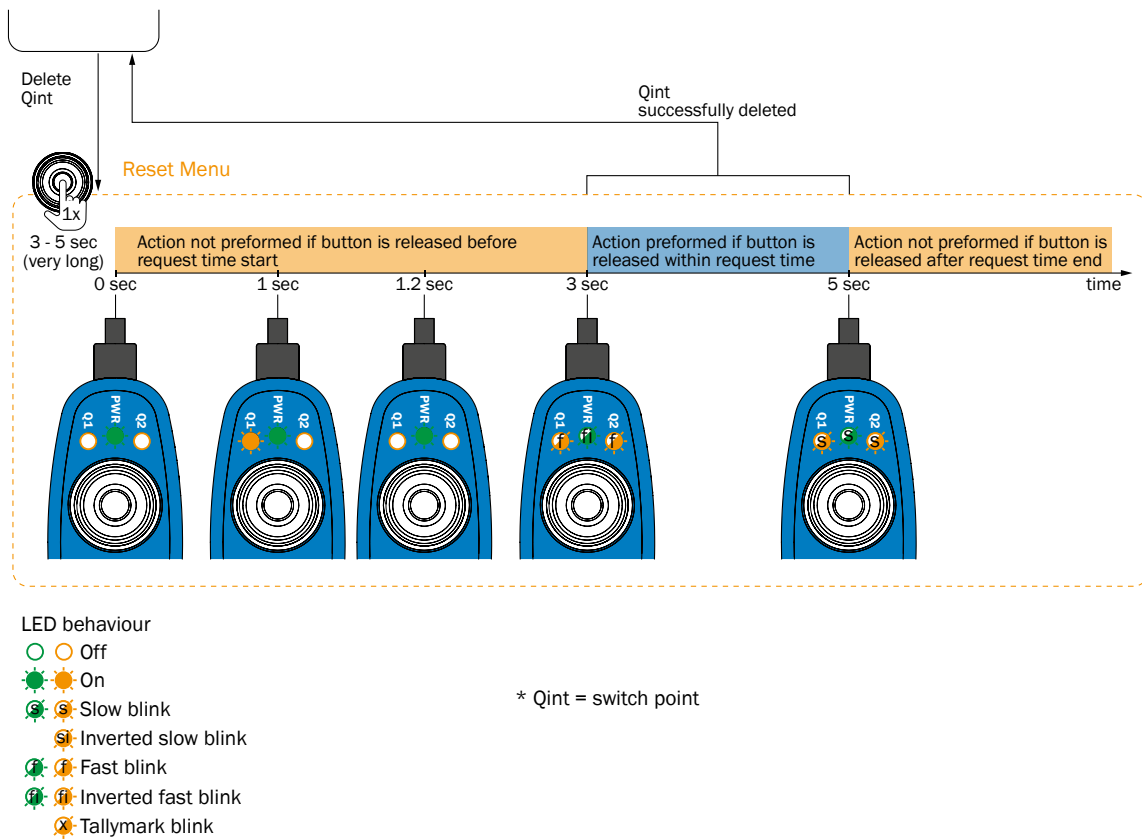

Figure 19: Dynamic Teach-in teach-in procedure

Flashing tally sheet:

- 1 mm = 1 x brief flash
- 2 mm = 2 x brief flashes
- 3 mm = 3 x brief flashes
- 4 mm = 4 x brief flashes
- 5 mm = 1 x long flash

### 8.3.2 Manual teach-in

Manual Teach-in is used to manually teach in up to three switching points within the measuring range using the teach-in button. The three switching points are taught-in separately.



**NOTE**

After Manual Teach-in is run, the width of the switching point (see "Switching behavior after Manual Teach of up to 3 switching points", page 11) can be set.



Regular Operation

Teach Menu

Manual Teach

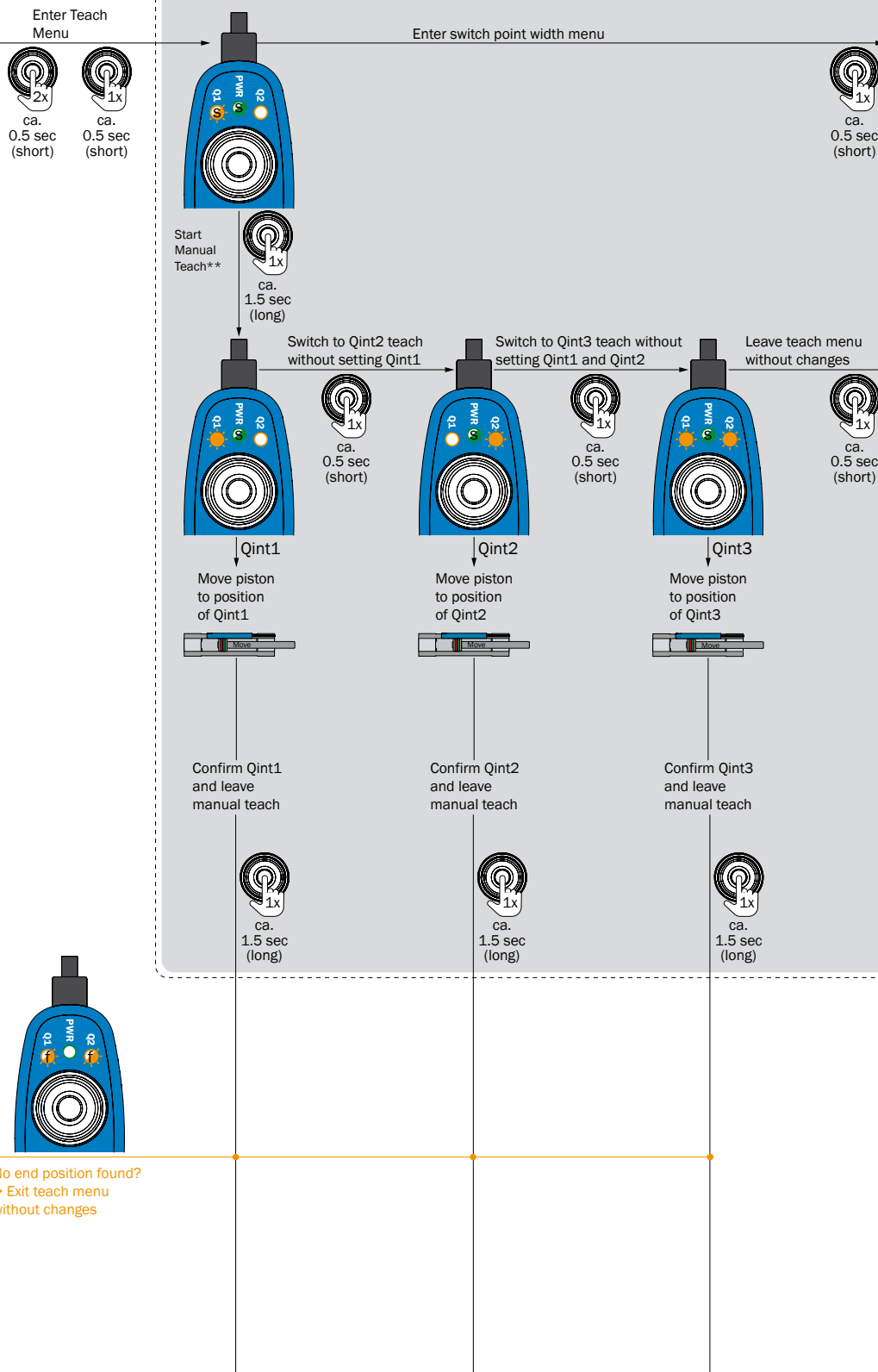

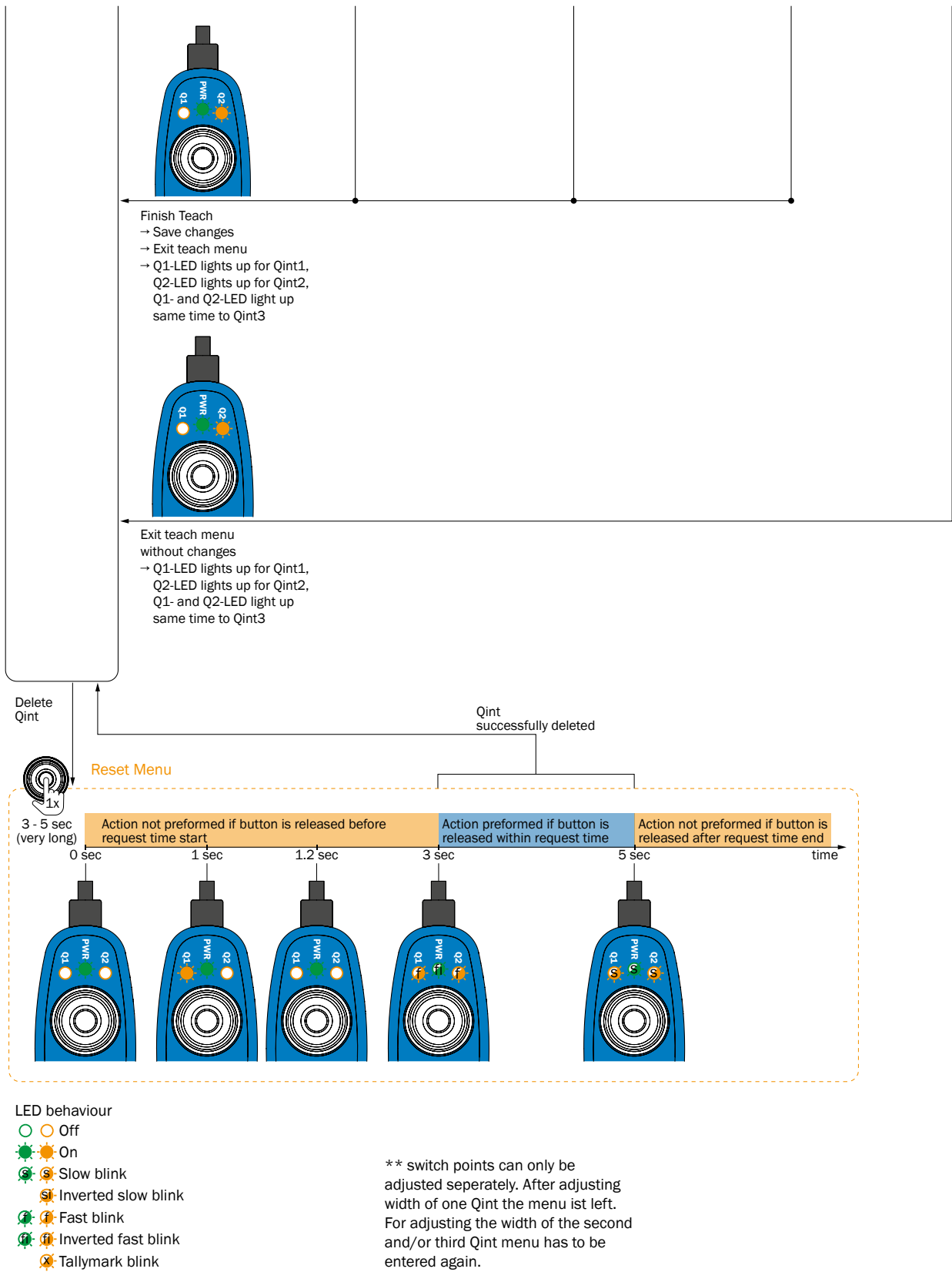
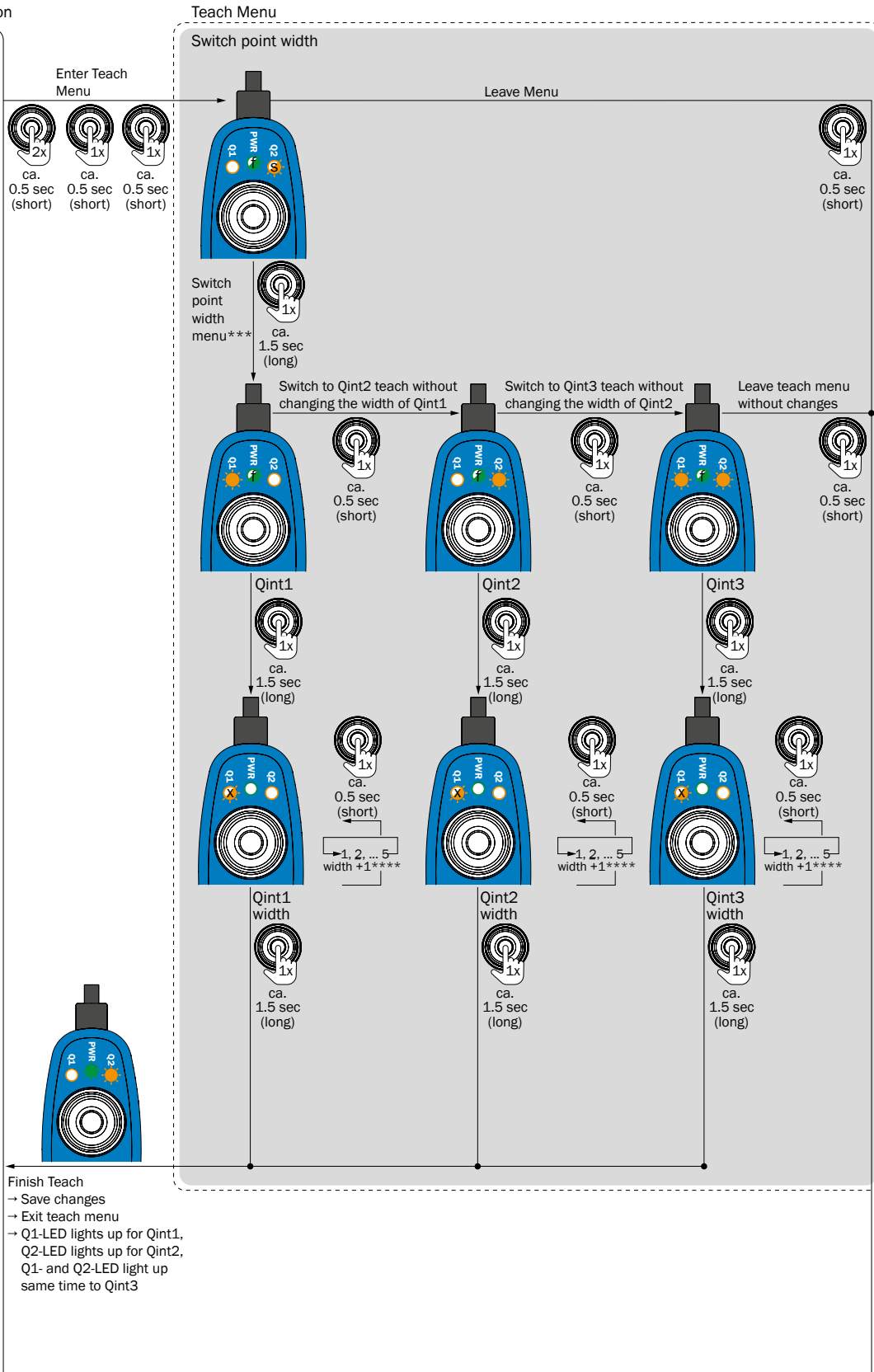

Figure 20: Manual Teach-in teach-in procedure

Setting of switching point width:

Regular Operation



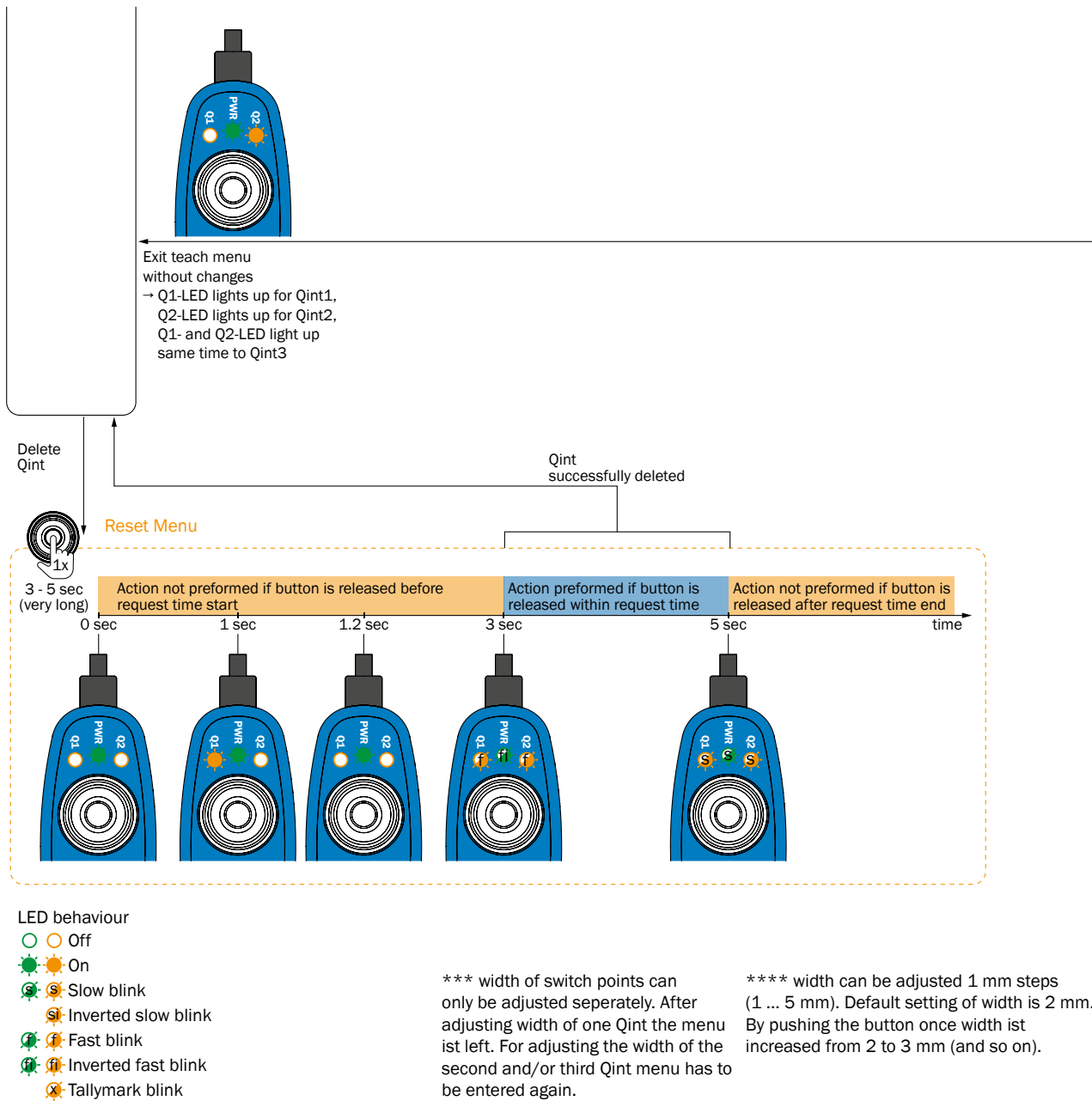

Figure 21: Teach routine for switching point width

Flashing tally sheet:

- 1 mm = 1 x brief flash
- 2 mm = 2 x brief flashes
- 3 mm = 3 x brief flashes
- 4 mm = 4 x brief flashes
- 5 mm = 1 x long flash

## 8.4 Operation via IO-Link

### 8.4.1 Process data structure

IO-Link version: 1.1

Process data length 4 bytes

Bitoffset								
Byte 0 / Description	31 / Measurement value	30 / Measurement value	29 / Measurement value	28 / Measurement value	27 / Measurement value	26 / Measurement value	25 / Measurement value	24 / Measurement value
Subindex								
Data Type	Integer 16							
Bitoffset	16							
Byte 1 / Description	23 / Measurement value	22 / Measurement value	21 / Measurement value	20 / Measurement value	19 / Measurement value	18 / Measurement value	17 / Measurement value	16 / Measurement value
Subindex	1							
Data Type	Integer 16							
Bitoffset	8							
Byte 2 / Description	15 / Scale	14 / Scale	13 / Scale	12 / Scale	11 / Scale	10 / Scale	9 / Scale	8 / Scale
Subindex	2							
Data Type	Integer 8							
Bitoffset	7	6	5	4	3	2	1	0
Byte 3 / Description	7 / QIntX/Alert	6 / QIntX/Alert	5 / QIntX/Alert	4 / QIntX/Alert	3 / QIntX/Alert	2 / QIntX/Alert	1 / QIntX/Alert	0 / QIntX/Alert
Subindex	3	4	5	6	7	8	9	10
Data Type	Boolean							

**NOTE**

Please note that the value of index 16512 **MDC Descr**, subindex 1 and 2 (**Measurement Range**) may change during operation of the sensor (while the sensor is being taught in for the drive).

## 8.4.2 General functions

The exact position is output in mm from -25 mm to +25 mm via byte 1 and 0 bit 16 to 31 of the process data. The scaling is specified by the sensor via byte 2 and up to 8 switching points can also be output via byte 3. Alternatively, alert notifications can be output via byte 3 instead of switching points.

For details, see [section 8.4.3.6](#).

## 8.4.3 Configuration options via IO-Link

The following settings can be configured using IO-Link:

- Pin 2 configuration (output)
- Lock teach-in button
- Reset
  - Device Reset
  - Restore Factory Settings
  - Reset diagnostic parameters
  - Reset all present alerts

- Reset operating hours counter
- Reset power cycles counter
- Reset actuator cycles counter
- Reset total actuator travel
- Reset all actuator diagnostics parameters
- Application reset
- Reset trained algorithm parameter
- Position offset
- Dynamic teach-in of 2 or 3 switching points
- Manual teach-in of up to 8 switching points
- Switching point modes
- Switching point logic (invert)
- Switching point hysteresis
- Switching point tolerance
- Switching point width
- Alert notifications

**8.4.3.1 Pin 2 configuration**

The physical pin 2 can be deactivated via index 121 (0x79) **Pin 2 configuration** and activated as Qint.2.

**8.4.3.2 Lock teach-in button**

The physical teach-in button on the sensor can be locked via index 12 (0x0C) **Device Access Locks** subindex 4 (0x04) **Local User Interface**.

**8.4.3.3 Reset**

**Device Reset**

No values/settings are deleted during this restart except for the volatile parameters. An overview of the volatile and non-volatile parameters can be found below, (index 2 (0x02) **System Command**, value 128):

*Table 11: Volatile and non-volatile parameters*

Index	Object name	Volatile / non-volatile
4372 (0x1114)	Actuator travel [x10 µm]	Volatile
4380 (0x111C)	Cycle time [ms]	Volatile
4381 (0x111D)	Dwell time [ms]	Volatile
4379 (0x111B)	Actuator travel time [ms]	Volatile
4375 (0x1117)	Average actuator velocity [m/s]	Volatile
4602 (0x11FA)	Current field strength [mT]	Volatile
4604 (0x111FC)	Peak field strength	Volatile
4374 (0x1116)	Total actuator travel [sum m]	Non-volatile
4382 (0x111E)	Cycle count [sum]	Non-volatile
	Qint. 1-8 SP1 / SP2 Qint. 1-8 Configuration	Non-volatile

**Restore Factory Settings**

When this command is executed, all settings made are reset to their default values, but not the indices 4356 (0x1104 **Operating hours**), 4357 (0x1105) **Power cycles**, subindex 1, 4382 (0x111E) **Cycle count [sum]** and 4374 (0x1116) **Total actuator travel [sum m]** (index 2 (0x02) **System Command**, value 130). The measured values of the algorithm are also reset, see **Reset trained algorithm parameter**.

**Reset Diagnostic Parameters**

This command resets the indices 4356 (0x1104) **Operating hours**, subindex 2 (0x02) **Since last reset**, 4357 (0x1105) **Power cycles**, subindex 2 (0x02) **Since last reset**, 4382 (0x111E) **Cycle count [sum]**, 4374 (0x1116) **Total actuator travel [sum m]** (index 2 (0x02) **System Command**, value 228).

**Reset all present alerts**

This command resets all set alert notifications (index 2 (0x02) **System Command**, value 229).

**Reset operating hours counter**

This command resets index 4356 (0x1104) **Operating hours**, subindex 2 (0x02) **Since last reset** (index 2 (0x02) **System Command**, value 228).

**Reset power cycles counter**

This command resets index 4357 (0x1105) **Power cycles** (index 2 (0x02) **System Command**, value 228).

**Reset actuator cycles counter**

This command resets index 4382 (0x111E) **Cycle Count [sum]** (index 4398 (0x112E) **Reset actuator diagnostics parameters**, value 2).

**Reset total actuator travel**

This command resets the index 4374 (0x1116) **Total actuator travel [sum m]** (index 4398 (0x112E) **Reset actuator diagnostics parameters**, value 1).

**Application reset**

This command behaves the same as **Restore factory settings**, except in this case the identification parameters (Index 24, 25, 26 and 64) are not reset (Index 2 (0x02) **System Command**, Value 129).

**Reset trained algorithm parameter**

This command has no effect on the diagnostic data or the settings made, only the measured values of the algorithm are reset. If the sensor is remounted from the taught-in drive onto a new drive, it is useful to perform this reset. This enables the sensor to be optimally taught in for the new drive in 2 strokes (index 2 (0x02) **System Command**, value 192).

**8.4.3.4 Position offset**

The position offset value in  $\mu\text{m}$  is added to the actual position value. This value can be set in 10  $\mu\text{m}$  increments via index 257 (0x101) **Position offset [x10 $\mu\text{m}$ ]**.

When the position offset in index 257 (0x101) **Position offset [x10  $\mu\text{m}$ ]** is changed, then the values in index 260 (0x104) **Detection range [x10  $\mu\text{m}$ ]** and index 16512 (0x4080) **MDC Descr**, subindex 1 and 2, change accordingly.

**8.4.3.5 Dynamic teach-in of 2 or 3 switching points**

The dynamic teach-in can be started via index 2 (0x02) **System Command**, value 75, stopped via value 76, and stored via value 77. The minimum distance between 2 switching points is always 1 mm for dynamic teach-in. An exact description of the dynamic teach-in can be found in [section 8.3.1](#). If the sensor detects 2 stops, the **Move** mode (subindex 2 (0x02) **Switchpoint Mode**, value 130) is automatically used, and if

3 stops are detected, the **Grip mode** (subindex 2 (0x02) **Switchpoint Mode**, value 131) is used. These two modes describe each respective switching behavior, which can be found in [section 8.3.1](#). For dynamic teach-in, no switching point modes can be selected.

#### 8.4.3.6 Manual teach-in of up to 8 switching points

In the following, the typical sequence of the manual teach-in is explained using Qint.1:

The start and end point of the switching point width can be set via index 60 (0x3C) **Qint.1 SP1 / SP2**. The start and end point can only be set in the **Window Mode** and **Two Point Mode** switching point mode. The switching point logic (subindex 1 (0x01) **Switchpoint Logic**), switching point mode (subindex 2 (0x02) **Switchpoint Mode**) and switching point hysteresis (subindex 3 (0x03) **Switchpoint Hysteresis**) can be set via index 61 (0x3D) **Qint.1 Configuration**. The index for configuring switching point 2 directly follows the index for switching point 1 Qint. 1. The switching points 3 to 8 can be configured from index 16384 (0x4000) to 16395 (0x400B). For manual teach-in, the distance between 2 switching points can be less than 1 mm. The only limiting factors here are repeatability and resolution. An exact description of the manual teach-in can be found in [section 8.3.2](#).

#### 8.4.3.7 Switching point modes

For switching points 1 to 8, the corresponding **Switchpoint Mode** index can be used to select between 4 different switching point modes after manual teach-in: **Single point mode**, **Window mode**, **Two point mode** and **Cylinder switch mode** (default).

- **Single point mode:** The switch-on point is defined by Qint.SP1. For all positions above this, the switching signal is **high**. The switch-off point is defined by Qint.SP1 minus hysteresis. For all positions below this point, the switching signal is **low**.



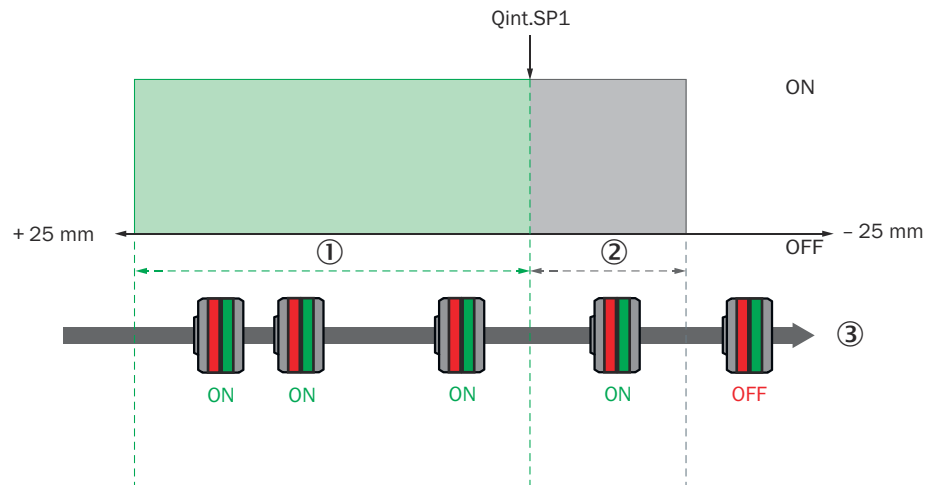
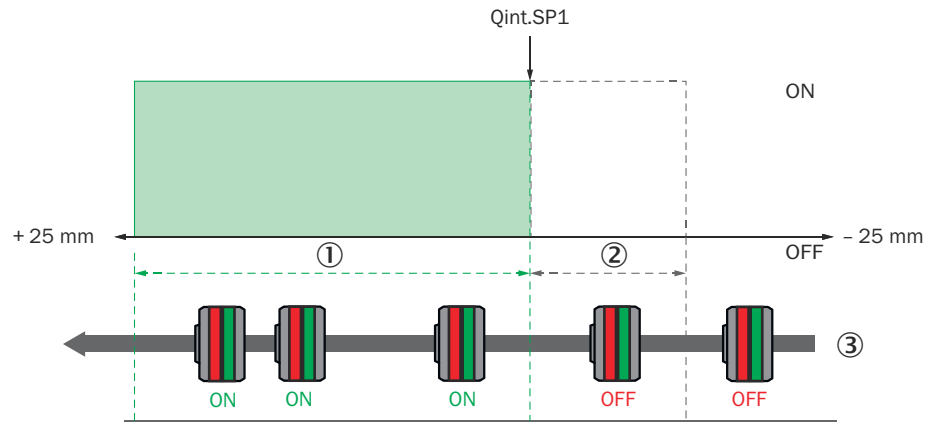

- ① Switching range
- ② Hysteresis
- ③ Direction of movement of the magnet

- **Window mode:** Qint.SP1 and Qint.SP2 define a switching window within which the switching signal is **high**. The hysteresis is symmetrical around each Qint.SP.

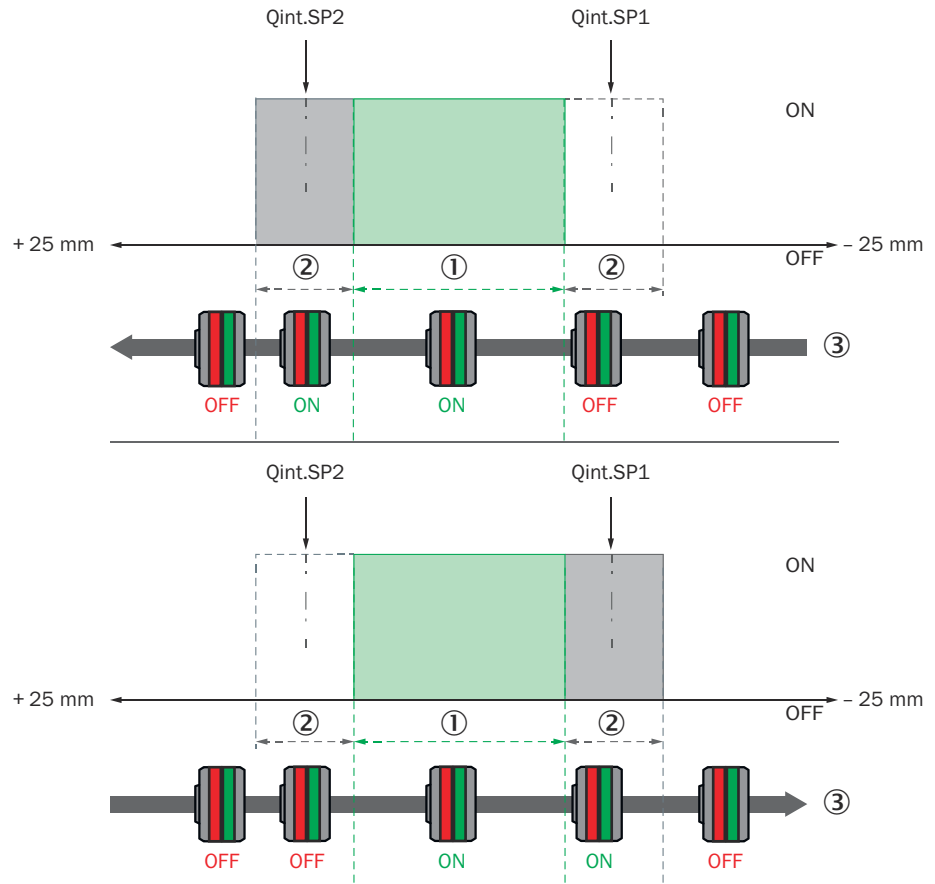

- ① Switching window
- ② Hysteresis
- ③ Direction of movement of the magnet

- **Two point mode:** Qint.SPx and Qint.SPy are determined. As soon as the magnet has passed Qint.SPx and Qint.SPy, the signal is **high**. As soon as the magnet is below Qint.SPx, the signal is **low**. (Qint.SPx < Qint.SPy)

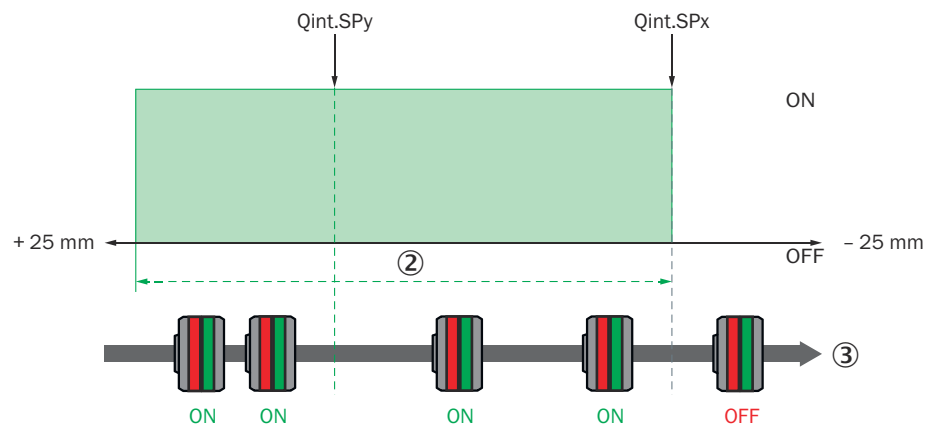
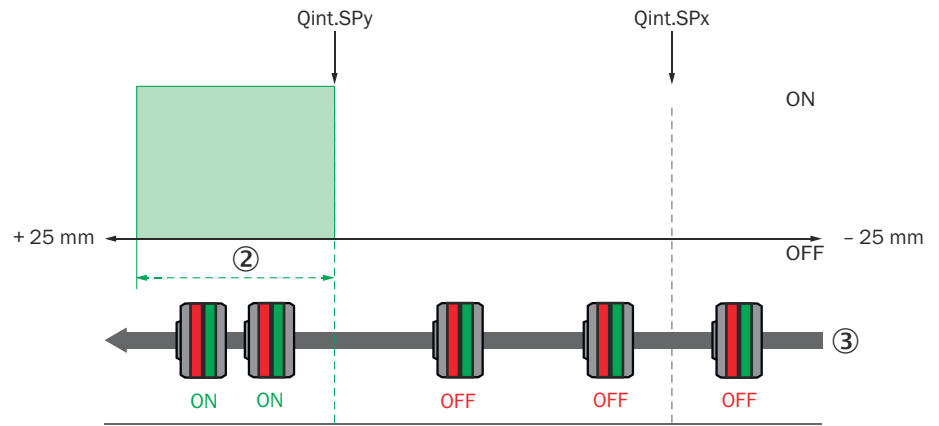

- ② Switching range
- ③ Direction of movement of the magnet

- Cylinder switch mode:** within the width of the switching point, the switching signal is high. The hysteresis is symmetrical around Qint.SP1. The switching signals switches to high as soon as the piston moves into the switching width and switches to low as soon as the piston leaves the hysteresis.

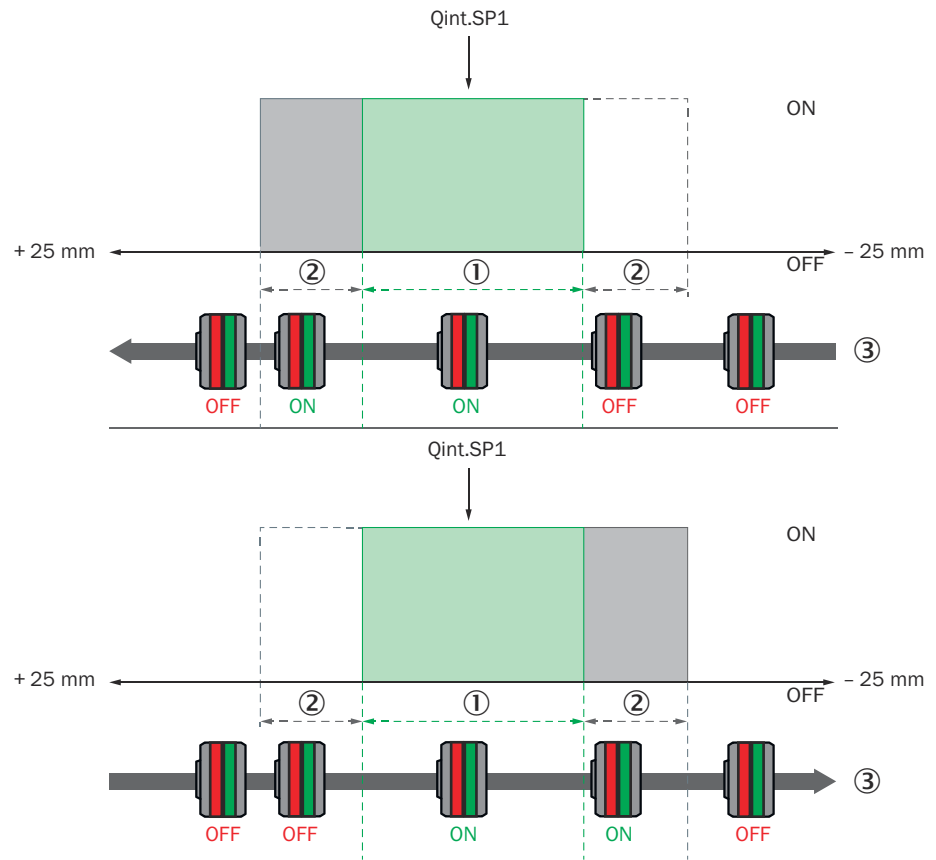

- ① Width of the switching point
- ② Hysteresis
- ③ Direction of movement of the magnet

Depending on whether 2 or 3 switching points are detected by the sensor during dynamic teach-in, the sensor automatically selects **Move** mode (for 2 switching points) or **Grip** mode (for 3 switching points). The two modes describe the switching behavior after dynamic teach-in.

The switching behavior in **Move** mode is described in [section 3.3.5](#) and the switching behavior in **Grip** mode is described in [section 3.3.6](#).

The **Move** and **Grip** modes are not available for manual teach-in. The 4 switching point modes described above are not intended to be selected after performing a dynamic teach-in.

### 8.4.3.8 Inverting the switchpoint logic

The logic of the taught-in switching points can be inverted using subindex 1 (0x01) **Switchpoint Logic**. By default, the switching points are high in the case of an overrun.

#### 8.4.3.9 Switching point hysteresis

After teaching in the switching point, the hysteresis is 0.7 mm. The hysteresis can be adjusted in 10 µm increments via subindex 3 (0x03) **Switchpoint Hysteresis** (maximum hysteresis: 327.67 mm and minimum hysteresis: 0.01 mm).

#### 8.4.3.10 Switching point tolerance

The switching point tolerance specifies the capture range in which a stop has an effect (switching output switches). The switching point tolerance can be set after dynamic teach-in via index 171 (0xAB) **Switchpoint tolerance [x10µm]**.



#### NOTE

This applies to **Move** and **Grip** modes only.

A detailed explanation can be found in [section 3.3.5](#) and [section 3.3.6](#). After a dynamic teach-in, the switching tolerance is 1 mm. The switching tolerance can be adjusted in 10 µm increments. After a manual teach-in, the concept of switching point width applies rather than switching point tolerance.

#### 8.4.3.11 Switching point width

After a manual teach-in, the width of the taught-in switching points can be determined via index 170 (0xAA) **Switchpoint width [x10µm]**. The default switching point width is 2 mm and the maximum switching point width is 10 mm.



#### NOTE

This applies to the **Cylinder switch mode** switching point mode only.

#### 8.4.3.12 Alert notifications

In general, the alert notifications are always activated and can be issued and read out when the set alert threshold is exceeded.

There are two ways to issue and read out the alert notifications: with the corresponding ISDU in the service data or via the process data.

By default, the alert is not output via the process data, but can be read out via the following indices:

- Index 4370 (0x1112) **DD - Alert flags**
- Index 4400 (0x1130) **Actuator alerts**

The alert thresholds can be changed using the following indices:

- Index 4369 (0x1111) **DD - Alert limit**
- Index 4399 (0x112F) **Actuator alert limits**

The process data can be set to alert notifications instead of switching points using the settings accessed via index 67 (0x43) **Process data user definition**.

The output via the process data has the advantage that the alert notifications do not have to be checked manually, but are transmitted on a regular basis.

- 60 = **Group alert: Cycle time** (type: event)  
Contents: index 4400 (0x1130) **Actuator alerts**, Subindex 2 (0x02) **Min. cycle time alert** and Subindex 3 (0x03) **Max. cycle time alert**
- 65 = **Direct alert: Operating hours max.** (type: event)
- 68 = **Direct alert: Power cycles max.** (type: event)
- 69 = **Direct alert: Cycle count max.** (type: event)
- 90 = **Direct alert: Total actuator travel max.** (type: event)

An alert delay time can be set for the alert notifications via index 4842 (0x12EA), subindex (0x01) **Alert delay time [ms]** and an automatic alert reset via subindex 2 (0x02) **Automatic alert reset time [ms]**.

The alert delay time in ms is the time by which the alert bits are delayed. An alert is only output if the corresponding alert condition is met for longer than the alert delay time defined here. The alert delay time can be set between 0 and 1,000 s in ms increments.

The configured alert delay time only affects alert notifications of type “Status”. Alert notifications of type “Event” occur immediately after falling below or exceeding the configured limit. The automatic alert reset specifies the time after which alerts are automatically reset if the alert bits in the process data do not change.

The automatic alert reset can be set between 0 and 1,000 s in ms increments. A negative value deactivates the automatic reset of alert notifications. By default, these two functions are not active.

#### 8.4.4 Actuator diagnostic functions

During the application, the MPS-G Smart Sensor also monitors:

- Traveled stroke(**Actuator travel**)
- **Cycle time**
- **Dwell time start position** and **Dwell time stop position**
- Travel time of the piston during extension (**Actuator travel time extend**) and during retraction (**Actuator travel time retract**)
- Average piston velocity during extension (**Average actuator velocity extend**) and during retraction (**Average actuator velocity retract**)
- Current measured field strength at sensor element 1 (**Current field strength sensor element 1**) and sensor element 2 (**Current field strength sensor element 2**)
- Maximum measured field strength at sensor element 1 (**Peak field strength sensor element 1**) and sensor element 2 (**Peak field strength sensor element 2**)
- **Cycle count**
- Total distance traveled by the piston (**Total actuator travel [sum]**)
- **Operating hours count**
- Power-on/power-off cycles (**Power cycles**)

The individual values are output via the IO-Link interface.

##### 8.4.4.1 Traveled stroke(Actuator travel)

The measured travel of the last stroke in mm is output via index 4372 (0x1114) **Actuator travel [x10µm]**.

##### 8.4.4.2 Cycle time

The duration of the last cycle in ms is output via index 4380 (0x111C) **Cycle time [ms]**. One cycle corresponds to 2 strokes: start position - stop position - start position.

The start position is in the direction of the sensor cable. The stop position is in the direction of the top of the sensor head.

A lower and upper threshold for the cycle time in ms can be defined via index 4399 (0x112F), subindex 2 (0x02) **Min. cycle time limit** and subindex 3 (0x03) **Max. cycle time limit**.

An alert is output via the process data when the value falls below the lower threshold or exceeds the upper threshold via index 4400 (0x1130), subindex 2 (0x02) **Min. cycle time alert** and subindex 3 (0x03) **Max. cycle time alert**.

#### 8.4.4.3 Dwell time at start position and stop position (Dwell time [ms])

The dwell time in ms at the start position and at the stop position can be read via index 4381 (0x111D) **Dwell time [ms]**, subindex 1 (0x01) **Start position** and subindex 2 (0x02) **Stop position**. The start position is in the direction of the cable of the sensor and the stop position is in the direction of the top of the sensor head.

#### 8.4.4.4 Travel time of the piston during extension and retraction (Actuator travel time)

The duration of the last stroke in ms in the positive direction (extension of the piston) can be read via index 4379 (0x111B) **Actuator travel time [ms]**, subindex 1 (0x01) **Extend (positive direction)**. The duration of the last stroke in ms in the negative direction (retraction of the piston) can be read via index 4379 (0x111B) **Actuator travel time [ms]**, subindex 2 (0x02) **Retract (negative direction)**.

The positive direction goes in the direction of the sensor fixing screw. One stroke corresponds to movement in a direction. Direction of movement during extension: Stop position – start position. The start position is in the direction of the sensor cable. The stop position is in the direction of the top of the sensor head.

The negative direction goes in the direction of the sensor cable. One stroke corresponds to movement in a direction. Direction of movement during retraction: Start position - stop position. The start position is in the direction of the sensor cable. The stop position is in the direction of the top of the sensor head.

#### 8.4.4.5 Average piston velocity during extension and retraction (Average actuator velocity)

The average velocity in m/s of the piston in the positive direction (extension of the piston) can be read via index 4375 (0x1117) **Average actuator velocity [m/s]**, subindex 1 (0x01) **Extend (positive direction)**.

The average velocity in m/s of the piston in the negative direction (retraction of the piston) can be read via index 4375 (0x1117) **Average actuator velocity [m/s]**, subindex 2 (0x02) **Retract (negative direction)**. The positive direction goes in the direction of the sensor fixing screw. The negative direction goes in the direction of the sensor cable.

#### 8.4.4.6 Current measured field strength at the sensor elements (Current field strength)

The current measured field strength for sensor element 1 in mT (**Sensor element 1**) and sensor element 2 in mT (**Sensor element 2**) can be read via index 4602 (0x11FA) **Current field strength [mT]**, subindex 1 (0x01) **Current1** and subindex 2 (0x02) **Current2**. Sensor element 1 is in the direction of the cable of the sensor and sensor element 2 is in the direction of the fixing screw of the sensor.

#### 8.4.4.7 Maximum measured field strength at the sensor elements (Peak field strength)

The maximum measured field strength for sensor element 1 in mT (**Sensor element 1**) and sensor element 2 in mT (**Sensor element 2**) since the last **Power cycle** can be read via index 4604 (0x11FC) **Peak field strength [mT]**, subindex 1 (0x01) **Current1** and subindex 2 (0x02) **Current2**. Sensor element 1 is in the direction of the cable of the sensor and sensor element 2 is in the direction of the fixing screw of the sensor.

#### 8.4.4.8 Cycle count

The number of cycles can be read via index 4382 (0x111E) **Cycle count [sum]**. One cycle corresponds to 2 strokes: start position - stop position - start position.

The start position is in the direction of the sensor cable. The stop position is in the direction of the sensor fixing screw.

The number of cycles is only stored in the EEPROM every 100 cycles. If the voltage supply is interrupted after 99 cycles, 0 cycles are read again via IO-Link after the voltage cycle. (This solution was chosen so that the EEPROM is not written to too often in order to ensure a long service life)

### 8.4.4.9 Total distance traveled by the piston (Total actuator travel)

The total distance traveled by the piston in m can be read via index 4374 (0x1116) **Total actuator travel [sum m]**. The total distance traveled by the piston is only stored in the EEPROM every 10 m.

If the voltage supply is interrupted after a travel distance of 9.99 m, 0.0 m is read again via IO-Link after the voltage cycle.

### 8.4.4.10 Operating hours

The operating hours in h is output via the index 4356 (0x1104) **Operating hours**. This index has three sub-indices, which corresponds to 3 different counters.

The first counts the absolute operating hours (1 (0x01) **Total**). The second counts the operating hours since the last **reset** (2 (0x02) **Since last reset**), and the third counts the time since the last **Power-on** (3 (0x03) **Since startup**).

### 8.4.4.11 Power-on / power-off cycles (Power cycles)

The **Power-on / power-off** cycles specify the number of times the device was switched on and off. 1 cycle corresponds to one **power-on** and one **power-off**. The **Power-on/ power-off cycles** can be read via index 4357 **Power cycles** (total number (subindex 1 (0x01) **Total**) and number since last reset (subindex 2 (0x02) **Since last reset**)).



## 9 Troubleshooting

Table 12: Possible error displays via the LEDs

LED/fault pattern / Fault pattern	Cause	Measures
Green LED does not light up	No voltage or voltage below the limit values	Check the power supply, check all electrical connections (cables and plug connections)
LED 1 + LED 3: Quick flashing	During a teach attempt outside the detection range, no end point is applied	Bring pistons into the detection range of the sensor
	If no or only one end point is found during <b>Dynamic Teach</b> , no end points are applied	Adjust the position so that two end points are found
Sensor position is imprecise	Mounting position unfavorable	Position sensor head as recommended in the operating instructions and run voltage reset
Sensor does not find switching points in Dynamic Pilot / does not switch	Traversing speed of the object is insufficient	Increase traversing speed of the piston or deactivate Dynamic Pilot and manually teach in switching points
Switching points are lost	Sensor was not yet completely taught in to drive	Perform several strokes (> 5) and reset switching points

### 10 Maintenance

SICK sensors are maintenance-free.

We do, however, recommend that the following activities are undertaken regularly:

- Clean the sensor surfaces
- Check the fittings and plug connectors

No modifications may be made to devices.

Subject to change without notice. Specified product properties and technical data are not written guarantees.

## 11 Decommissioning

### 11.1 Replace device

The **IO-Link Data Storage** function can be used to save previous parameters and transmit them to the exchange device. This prevents complete re-parameterization of the exchange device.

### 11.2 Disassembly and disposal

#### Disassembling the device

1. Switch off the supply voltage to the device.
2. Detach all connecting cables from the device.
3. If the device is being replaced, mark its position and alignment on the bracket or surroundings.
4. Detach the device from the bracket.

#### Disposing of the device

Any device which can no longer be used must be disposed of in an environmentally friendly manner in accordance with the applicable country-specific waste disposal regulations.



#### NOTE

##### Disposal of batteries, electric and electronic devices

- According to international directives, batteries, accumulators and electrical or electronic devices must not be disposed of in general waste.
- The owner is obliged by law to return this devices at the end of their life to the respective public collection points.



 This symbol on the product, its package or in this document, indicates that a product is subject to these regulations.

### 11.3 Returning devices

- ▶ Do not dispatch devices to the SICK Service department without consultation.



#### NOTE

To enable efficient processing and allow us to determine the cause quickly, please include the following when making a return:

- Details of the contact person
- Description of the application
- Description of the fault that occurred

## 12 Technical data

Table 13: Technical data

Cylinder type	C-slot
Detection zone	0 ... 50 mm <sup>1)</sup>
Supply voltage U <sub>B</sub>	10 ... 30 V DC
Power consumption	≤ 550 mW
Required magnetic field strength, typ.	≥ 2 mT
overrun distance	can be configured
Hysteresis	can be configured
Time delay before availability	0.15 s
Resolution typ.	0.01 mm
Linearity typ.	0.3 mm <sup>2)</sup>
Repeatability (response time) typ.	0.05 mm <sup>3)</sup>
Sampling rate min.	2 kHz
IO-Link	1.1
Enclosure rating	IP67
Protection class	III
Circuit protection	A, B, D <sup>4)</sup>
Ambient temperature, operation	-20 °C ... +70 °C

1) Deviations are possible depending on the drive.

2) At 25 °C, the linearity error (maximum deviation) depends on response curve and minimum deviation function.

3) At 25 °C, repeatability with magnet movement from one direction.

4) A = UB connections reverse polarity protected  
 B = Inputs and outputs reverse polarity protected  
 C = Interference suppression  
 D = Outputs overcurrent and short-circuit protected

12.1 Dimensional drawing

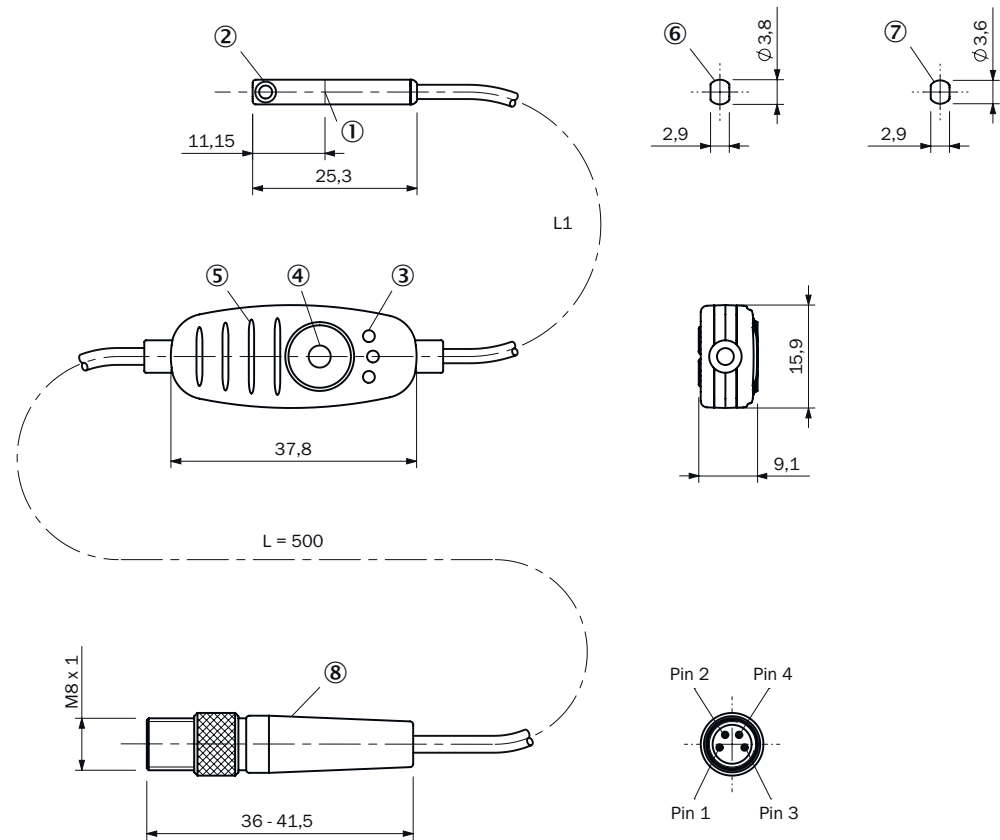

Figure 22: Dimensional drawing with male connector, M8 knurled

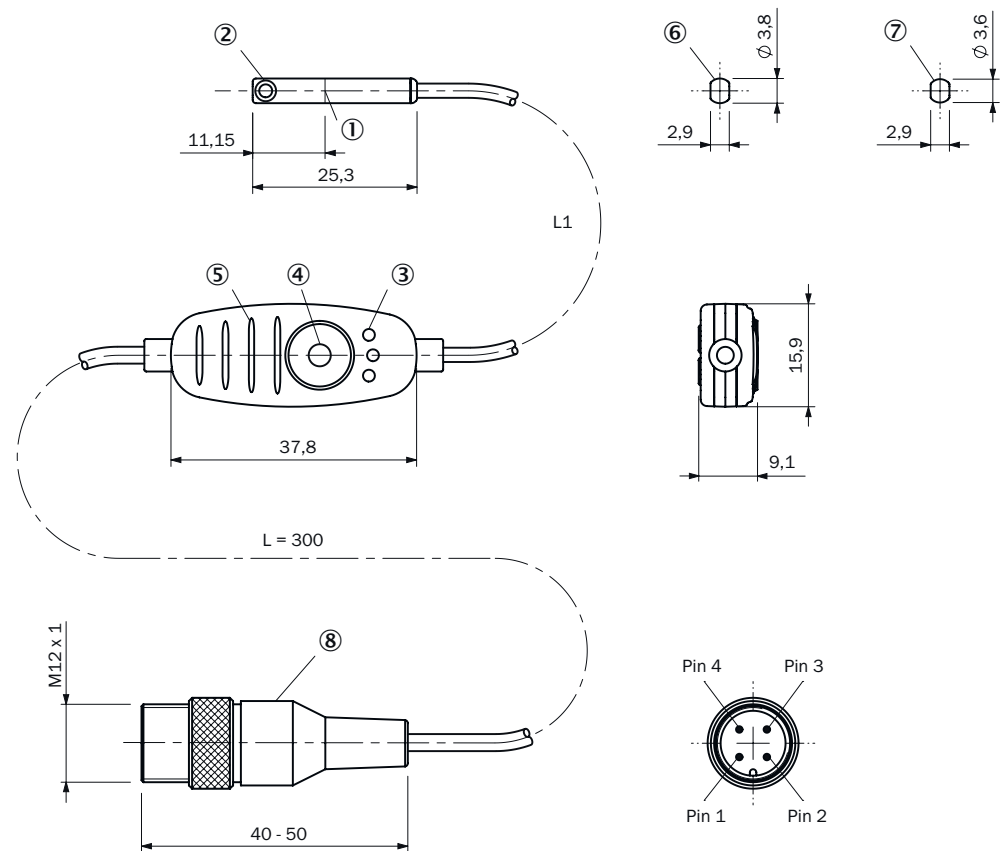

Figure 23: Dimensional drawing with male connector, M12 knurled

- ① Center sensor element
- ② Fixing screw, size 1.3
- ③ LED
- ④ Teach-in button
- ⑤ Ribs for cable tie
- ⑥ For SMC, Schunk, PHD, Bimba slot (MPS-G50CS...)
- ⑦ For Festo-, Zimmer slot (MPS-G50CF...)
- ⑧ Connection

Table 14: L1 length of sensor head / control panel connection cable

Type code	Connection cable length
MPS-Gxxxxx1xxxxxxxxxxxxxxxxxxxx	0.1 m
MPS-Gxxxxx5xxxxxxxxxxxxxxxxxxxx	0.5 m

## 13 Glossary

<b>Cycle time</b>	<p>Duration of the last cycle in ms.</p> <p>One cycle corresponds to 2 strokes: Start position – stop position – start position</p> <p>The start position is in the direction of the sensor cable.</p> <p>The stop position is in the direction of the sensor fixing screw.</p>
<b>Detection range</b>	<p>The detection range describes the maximum physical range in which the sensor can determine a position. The detection range is max. +30 mm and - 30 mm around the physical zero position.</p>
<b>Dwell time stop position</b>	<p>Dwell time in stop position in ms.</p> <p>The stop position is in the direction of the sensor fixing screw.</p>
<b>Dynamic Pilot</b>	<p><b>Dynamic Pilot</b> sets an additional condition for the switching process during operation:</p> <p>In addition to the condition that the magnet must be located within the tolerance band defined in <b>Dynamic Teach</b>, the speed of the magnet must also be <math>v = 0</math> and the approach direction must correspond in order to switch on.</p> <ul style="list-style-type: none"> <li>• Qint switches on ... ... when a magnet moves into the tolerance band and <math>v = 0</math> for the first time within this tolerance band. (The approach direction must be plausible according to the Move and Grip applications, see figures in <a href="#">section 3.3.6</a>)</li> <li>• After switching on, Qint remains on ... ... as long as the magnet is within the tolerance band and the hysteresis (depending on whether <math>v = 0</math> or <math>v \neq 0</math>).</li> <li>• Qint switches off ... ... as soon as the magnet leaves the hysteresis.</li> </ul>
<b>Dynamic Teach and Manual Teach</b>	<p><b>Dynamic Teach</b> and <b>Manual Teach</b> are two different teach options. The teach-in button can be used to execute both <b>Dynamic Teach</b> and <b>Manual Teach</b>.</p> <ul style="list-style-type: none"> <li>• <b>Dynamic Teach:</b> <b>Dynamic Teach</b> can be used to have the sensor automatically set the end points of the desired measuring range.</li> <li>• <b>Manual Teach:</b> <b>Manual Teach</b> is used to manually teach in the two end points of the measuring range using the teach-in button. Both end points are taught in separately.</li> </ul> <p>The teach-in processes are described in detail in <a href="#">section 8.3</a>.</p>
<b>Linearity error</b>	<p>The linearity error describes the maximum deviation of the output signal from an ideal straight line. It is measured in millimeters.</p> <p>MPS-G with 2/3 digital switching points and IO-Link (up to 16 switching points): The linearity error is typically 0.5 mm and depends on the measuring range and the drive on which the sensor is mounted.</p>
<b>Maximum measured field strength at sensor element 1</b>	<p>Maximum measured field strength for sensor element 1 in mT.</p> <p>This value is recalculated each time the element is passed over. Sensor element 1 is in the direction of the sensor cable.</p>
<b>Measuring range</b>	<p>The measuring range can be anywhere inside the detection range. The measuring range must always be completely inside the detection range.</p>

<b>Offset</b>	The offset is added to the position identified by the sensor. Negative position values can be output depending on the positioning of the sensor on the drive. If you do not want this, an offset value can be defined around which all position values are added. Position output = identified position of the sensor + offset value. The offset value is specified in digits. 1 digit corresponds to 10 µm.
<b>Piston velocity</b>	Average speed of the piston during extension: Average measured speed of the stroke in the positive direction in m/s. The positive direction goes in the direction of the sensor fixing screw. Average speed of the piston during retraction: Average measured speed of the stroke in the negative direction in m/s. The negative direction goes in the direction of the sensor cable.
<b>Qint</b>	Qint.SP: SP = switching point
<b>Range of movement</b>	The range of movement describes the actual path traveled by the piston.
<b>Repeatability</b>	Repeatability is defined as any move to a preset position from the same direction in every case. MPS-G with 2/3 digital switching points and IO-Link (up to 16 switching points): The repeatability is typically 0.05 mm and depends on the drive on which the sensor is mounted.
<b>Resolution</b>	The sensor resolution describes the minimum, specifiable magnet route change as output by the sensor. MPS-G with 2/3 digital switching points and IO-Link (up to 16 switching points): The resolution is 0.01 mm.
<b>Sampling rate</b>	The sampling rate indicates the time interval in which the signal is updated at the outputs. MPS-G with 2/3 digital switching points and IO-Link (up to 16 switching points): The sampling rate is min. 2 kHz.
<b>Stroke traveled</b>	Measured travel of the last stroke in mm
<b>Total distance traveled by the piston</b>	Total travel of the piston in m
<b>Travel time of the piston during extension</b>	Duration of the last stroke in the positive direction in ms. The positive direction goes in the direction of the sensor fixing screw. One stroke corresponds to movement in a direction. Direction of movement during extension: Stop position – start position. The start position is in the direction of the sensor cable. The stop position is in the direction of the sensor fixing screw.



# 14 Annex

## 14.1 Teach routine at a glance

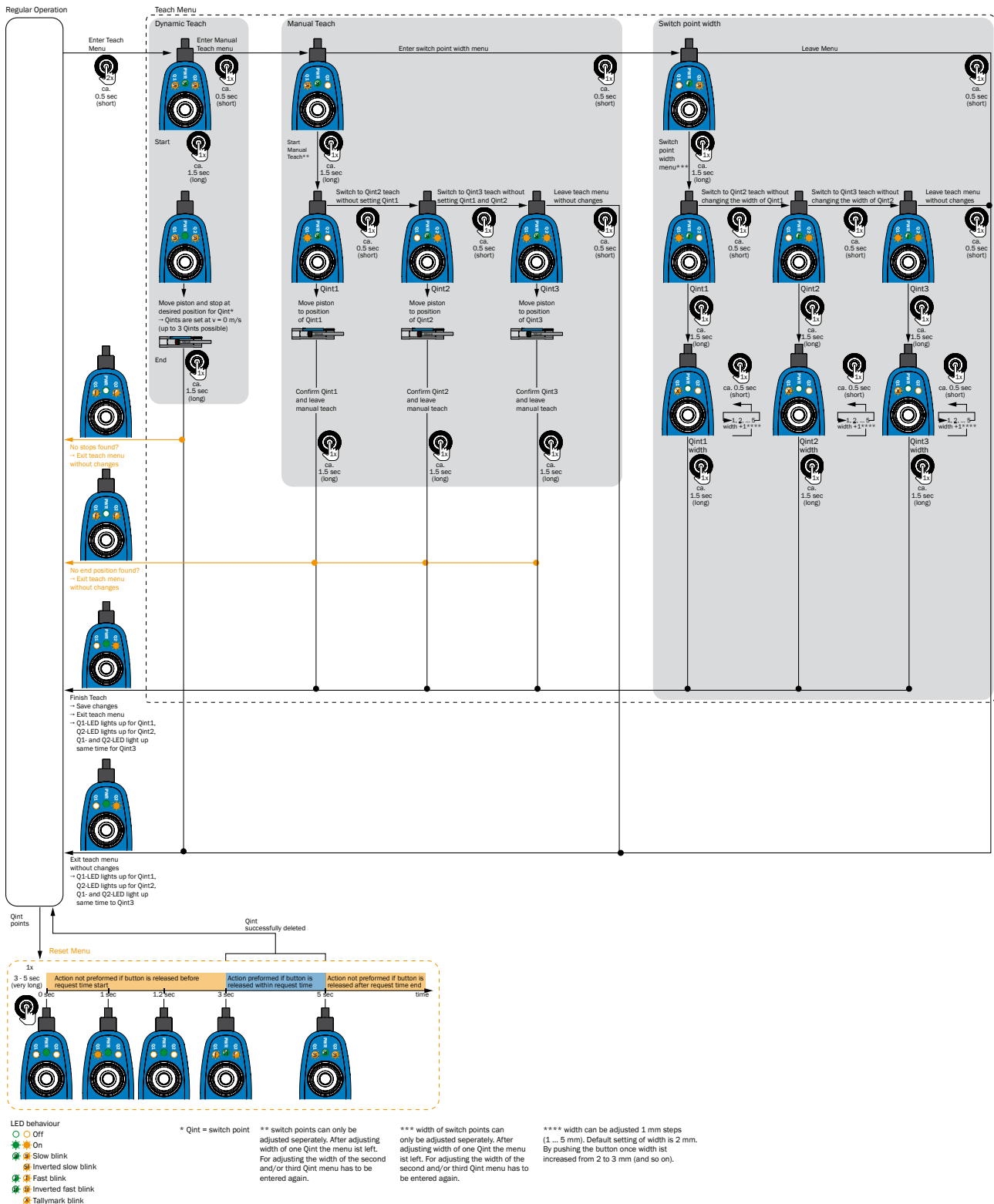

Figure 24: MPS-G IO-Link teach routine

### 14.2 Conformities and certificates

You can obtain declarations of conformity, certificates and the current documentation for the product at [www.sick.com](http://www.sick.com). To do so, enter the product part number in the search field (part number: see the entry in the “P/N” or “Ident. no.” field on the type label).



**Australia**

Phone +61 (3) 9457 0600  
1800 33 48 02 – tollfree  
E-Mail sales@sick.com.au

**Austria**

Phone +43 (0) 2236 62288-0  
E-Mail office@sick.at

**Belgium/Luxembourg**

Phone +32 (0) 2 466 55 66  
E-Mail info@sick.be

**Brazil**

Phone +55 11 3215-4900  
E-Mail comercial@sick.com.br

**Canada**

Phone +1 905.771.1444  
E-Mail cs.canada@sick.com

**Czech Republic**

Phone +420 234 719 500  
E-Mail sick@sick.cz

**Chile**

Phone +56 (2) 2274 7430  
E-Mail chile@sick.com

**China**

Phone +86 20 2882 3600  
E-Mail info.china@sick.net.cn

**Denmark**

Phone +45 45 82 64 00  
E-Mail sick@sick.dk

**Finland**

Phone +358-9-25 15 800  
E-Mail sick@sick.fi

**France**

Phone +33 1 64 62 35 00  
E-Mail info@sick.fr

**Germany**

Phone +49 (0) 2 11 53 010  
E-Mail info@sick.de

**Greece**

Phone +30 210 6825100  
E-Mail office@sick.com.gr

**Hong Kong**

Phone +852 2153 6300  
E-Mail ghk@sick.com.hk

**Hungary**

Phone +36 1 371 2680  
E-Mail erteakesites@sick.hu

**India**

Phone +91-22-6119 8900  
E-Mail info@sick-india.com

**Israel**

Phone +972 97110 11  
E-Mail info@sick-sensors.com

**Italy**

Phone +39 02 27 43 41  
E-Mail info@sick.it

**Japan**

Phone +81 3 5309 2112  
E-Mail support@sick.jp

**Malaysia**

Phone +603-8080 7425  
E-Mail enquiry.my@sick.com

**Mexico**

Phone +52 (472) 748 9451  
E-Mail mexico@sick.com

**Netherlands**

Phone +31 (0) 30 204 40 00  
E-Mail info@sick.nl

**New Zealand**

Phone +64 9 415 0459  
0800 222 278 – tollfree  
E-Mail sales@sick.co.nz

**Norway**

Phone +47 67 81 50 00  
E-Mail sick@sick.no

**Poland**

Phone +48 22 539 41 00  
E-Mail info@sick.pl

**Romania**

Phone +40 356-17 11 20  
E-Mail office@sick.ro

**Singapore**

Phone +65 6744 3732  
E-Mail sales.gsg@sick.com

**Slovakia**

Phone +421 482 901 201  
E-Mail mail@sick-sk.sk

**Slovenia**

Phone +386 591 78849  
E-Mail office@sick.si

**South Africa**

Phone +27 10 060 0550  
E-Mail info@sickautomation.co.za

**South Korea**

Phone +82 2 786 6321/4  
E-Mail infokorea@sick.com

**Spain**

Phone +34 93 480 31 00  
E-Mail info@sick.es

**Sweden**

Phone +46 10 110 10 00  
E-Mail info@sick.se

**Switzerland**

Phone +41 41 619 29 39  
E-Mail contact@sick.ch

**Taiwan**

Phone +886-2-2375-6288  
E-Mail sales@sick.com.tw

**Thailand**

Phone +66 2 645 0009  
E-Mail marcom.th@sick.com

**Turkey**

Phone +90 (216) 528 50 00  
E-Mail info@sick.com.tr

**United Arab Emirates**

Phone +971 (0) 4 88 65 878  
E-Mail contact@sick.ae

**United Kingdom**

Phone +44 (0)17278 31121  
E-Mail info@sick.co.uk

**USA**

Phone +1 800.325.7425  
E-Mail info@sick.com

**Vietnam**

Phone +65 6744 3732  
E-Mail sales.gsg@sick.com

Detailed addresses and further locations at [www.sick.com](http://www.sick.com)

