

deTec2 Core Vibes

Safety light curtain

SICK
Sensor Intelligence.



Described product

deTec2 Core Vibes

Manufacturer

SICK AG
Erwin-Sick-Str. 1
79183 Waldkirch
Germany

Legal information

This work is protected by copyright. Any rights derived from the copyright shall be reserved for SICK AG. Reproduction of this document or parts of this document is only permissible within the limits of the legal determination of Copyright Law. Any modification, abridgment or translation of this document is prohibited without the express written permission of SICK AG.

The trademarks stated in this document are the property of their respective owner.

© SICK AG. All rights reserved.

Original document

This document is an original document of SICK AG.



Contents

1	About this document.....	6
1.1	Purpose of this document.....	6
1.2	Scope.....	6
1.3	Target groups of these operating instructions.....	6
1.4	Additional information.....	6
1.5	Symbols and document conventions.....	7
2	Safety information.....	8
2.1	General safety notes.....	8
2.2	Intended use.....	8
2.3	Inappropriate use.....	8
2.4	Requirements for the qualification of personnel.....	9
3	Product description.....	10
3.1	Structure and function.....	10
3.2	Product characteristics.....	11
3.2.1	Device overview.....	11
3.2.2	Absence of blind zones.....	11
3.2.3	Alignment aid.....	11
3.2.4	Status indicators.....	11
3.3	Example applications.....	13
4	Project planning.....	15
4.1	Manufacturer of the machine.....	15
4.2	Operating entity of the machine.....	15
4.3	Design.....	15
4.3.1	Scanning range and protective field width.....	16
4.3.2	Minimum distance from the hazardous point.....	16
4.3.3	Minimum distance to reflective surfaces.....	19
4.3.4	Protection against interference from systems in close proximity to each other.....	21
4.4	Integration in electrical control.....	23
4.4.1	Restart interlock.....	25
4.4.2	External device monitoring (EDM).....	26
4.4.3	Connection diagrams.....	27
4.5	Testing plan.....	27
4.5.1	Test rod check.....	28
4.5.2	Visual check of the machine and the protective device.....	31
5	Mounting.....	32
5.1	Safety.....	32
5.2	Unpacking.....	32
5.3	Installation.....	32
5.3.1	Mounting the QuickFix bracket.....	36

6	Electrical installation.....	38
6.1	Safety.....	38
6.2	System connection (M12, 5-pin).....	39
6.3	System connection via connection cable (M12, 5-pin to 8-pin).....	40
7	Commissioning.....	41
7.1	Overview.....	41
7.2	Switching on.....	41
7.3	Sender and receiver alignment.....	41
7.3.1	Aligning the sender and receiver.....	42
7.3.2	Alignment with the QuickFix bracket.....	43
7.3.3	Indication of the alignment quality.....	43
7.4	Check during commissioning and modifications.....	44
8	Operation.....	45
8.1	Regular thorough check.....	45
9	Maintenance.....	46
9.1	Regular cleaning.....	46
9.2	Regular thorough check.....	47
10	Troubleshooting.....	48
10.1	Safety.....	48
10.2	Diagnostic LEDs.....	48
10.2.1	Fault indicators.....	48
11	Decommissioning.....	50
11.1	Disposal.....	50
12	Technical data.....	51
12.1	Data sheet.....	51
12.2	Response time.....	53
12.3	Power consumption.....	54
12.4	Length of cable.....	54
12.5	Table of weights.....	54
12.6	Dimensional drawings.....	55
13	Ordering information.....	57
13.1	Scope of delivery.....	57
14	Accessories.....	58
14.1	Brackets.....	58
14.2	Mounting accessories.....	58
14.3	Connectors.....	58
14.4	Alignment aid.....	59
14.5	Cleaning agent.....	60
14.6	Test rods.....	60

15	Annex.....	61
15.1	Conformities and certificates.....	61
15.1.1	EU declaration of conformity.....	61
15.1.2	UK declaration of conformity.....	61
15.2	Note on standards.....	61
15.3	Checklist for initial commissioning and commissioning.....	63
16	List of figures.....	64
17	List of tables.....	65

1 About this document

1.1 Purpose of this document

These operating instructions contain information required during the life cycle of the safety light curtain.

These operating instructions are available to all those who work with the safety light curtain.

Please read these operating instructions carefully and make sure that you understand the content fully before working with the safety light curtain.

1.2 Scope

This document applies to the following products:

- Product code: deTec2 Core Vibes
- "Operating instructions" type label entry: 8024474

Document identification

Document part number:

- This document: 8024476
- Available language versions of this document: 8024474

You can find the current version of all documents at www.sick.com.

1.3 Target groups of these operating instructions

Some sections of these operating instructions are intended for certain target groups. However, the entire operating instructions are relevant for intended use of the product.

Table 1: Target groups and selected sections of these operating instructions

Target group	Sections of these operating instructions
Project developers (planners, developers, designers)	"Project planning", page 15 "Technical data", page 51 "Accessories", page 58
Installers	"Mounting", page 32
Electricians	"Electrical installation", page 38
Safety experts (such as CE authorized representatives, compliance officers, people who test and approve the application)	"Project planning", page 15 "Commissioning", page 41 "Technical data", page 51 "Checklist for initial commissioning and commissioning", page 63
Operators	"Operation", page 45 "Troubleshooting", page 48
Maintenance personnel	"Maintenance", page 46 "Troubleshooting", page 48

1.4 Additional information

www.sick.com

The following information is available on the Internet:

- Data sheets and application examples
- CAD data and dimensional drawings

- Certificates (e.g. EU declaration of conformity)
- Guide for Safe Machinery Six steps to a safe machine

1.5 Symbols and document conventions

The following symbols and conventions are used in this document:

Safety notes and other notes



DANGER

Indicates a situation presenting imminent danger, which will lead to death or serious injuries if not prevented.



WARNING

Indicates a situation presenting possible danger, which may lead to death or serious injuries if not prevented.



CAUTION

Indicates a situation presenting possible danger, which may lead to moderate or minor injuries if not prevented.



NOTICE

Indicates a situation presenting possible danger, which may lead to property damage if not prevented.



NOTE

Indicates useful tips and recommendations.

Instructions to action

- ▶ The arrow denotes instructions to action.
- 1. The sequence of instructions for action is numbered.
- 2. Follow the order in which the numbered instructions are given.
- ✓ The check mark denotes the result of an instruction.

LED symbols

These symbols indicate the status of an LED:

- The LED is off.
- ◐ The LED is flashing.
- The LED is illuminated continuously.

Sender and receiver

These symbols indicate the sender and receiver of the device:

- ➡ The symbol indicates the sender.
- ⬅ The symbol indicates the receiver.

2 Safety information

2.1 General safety notes



DANGER

The product can not offer the expected protection if it is integrated incorrectly.

- ▶ Plan the integration of the product in accordance with the machine requirements (project planning).
 - ▶ Implement the integration of the product in accordance with the project planning.
-



DANGER

Death or severe injury due to electrical voltage and/or an unexpected startup of the machine

- ▶ Make sure that the machine is (and remains) disconnected from the voltage supply during mounting and electrical installation.
 - ▶ Make sure that the dangerous state of the machine is and remains switched off.
-



DANGER

Improper work on the product

A modified product may not offer the expected protection if it is integrated incorrectly.

- ▶ Apart from the procedures described in this document, do not repair, open, manipulate or otherwise modify the product.
-

2.2 Intended use

The deTec2 Core Vibes safety light curtain is an electro-sensitive protective device (ESPE) and is suitable for the following applications:

- Hazardous point protection
- Access protection
- Hazardous area protection

The product may be used in safety functions.

The deTec2 Core Vibes safety light curtain must only be used within the limits of the prescribed and specified technical data and operating conditions at all times.

Any instance of improper use, incorrect modification, or manipulation of the deTec2 Core Vibes safety light curtain shall void any warranty provided by SICK AG; furthermore, SICK AG shall not accept any responsibility or liability for any resulting damage and consequential damage.

2.3 Inappropriate use

The safety light curtain works as an indirect protective measure and cannot provide protection from parts thrown out nor from emitted radiation. Transparent objects are not detected.

Among others, the deTec2 Core Vibes safety light curtain is not suitable for the following applications:

- Outdoors
- Underwater
- In explosion-hazardous areas

- At altitudes over 3,000 m above sea level
- In environments with increased levels of ionizing radiation

2.4 Requirements for the qualification of personnel

The safety light curtain must only be configured, installed, connected, commissioned and serviced by qualified safety personnel.

Project planning

You need safety expertise to implement safety functions and select suitable products for that purpose. You need expert knowledge of the applicable standards and regulations.

Mounting, electrical installation and commissioning

You need suitable expertise and experience. You must be able to assess if the machine is operating safely.

Operation and maintenance

You need suitable expertise and experience. You must be instructed in machine operation by the machine operator. For maintenance, you must be able to assess if the machine is operating safely.

3 Product description

3.1 Structure and function

Overview

The deTec2 Core Vibes safety light curtain is an electro-sensitive protective device (ESPE) consisting of a sender and receiver.

A series of parallel infrared light beams forms a protective field between sender and receiver that protects the hazardous area (hazardous point, access, and hazardous area protection). When one or more beams are completely interrupted, the safety light curtain reports the interruption in the light path to the secure output signal switching devices (OSSDs) by a signal change. The machine or its control must safely analyze the signals (for example using a safe control or safety relays) and stop the dangerous state.

Sender and receiver automatically synchronize themselves optically. An electrical connection between both components is not required.

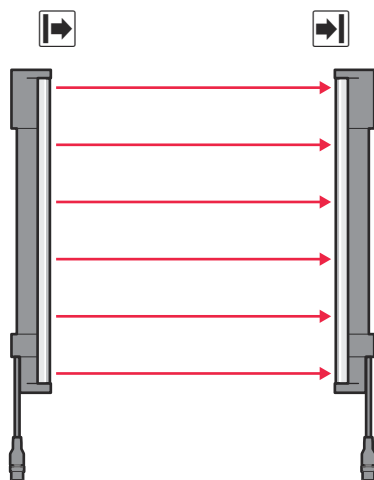

Figure 1: Sender and receiver

Protective field height

The protective field height indicates the range within which the test rod belonging to the safety light curtain is reliably detected.

Protective field width

The protective field width is the dimension of the light path between sender and receiver. The maximum protective field width is limited by the scanning range.

Resolution

The resolution describes the size of the smallest object detected by the safety light curtain in the protective field. The resolution corresponds to the diameter of the test rod belonging to the safety light curtain.

The safety light curtain has a resolution of 30 mm. This resolution provides hand protection.

Scanning range

The scanning range is the maximum protective field width.

The sensing sensing range is dependent on the receiver used.

Further topics

- ["Data sheet", page 51](#)

3.2 Product characteristics**3.2.1 Device overview**

Figure 2: Device overview

- ① Sender or receiver
- ② System connection

3.2.2 Absence of blind zones

The design and construction of the safety light curtain extends the protective function of a device to the end of the housing without any blind spots. The absence of blind zones reduces the space requirement when integrated in the machine.

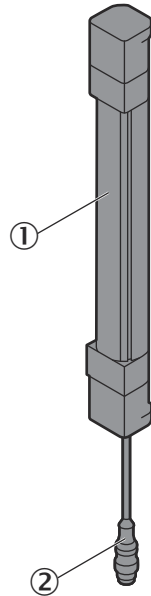
3.2.3 Alignment aid

Alignment quality LEDs are installed in the receiver of the safety light curtain. To perform a simple alignment of the receiver, the alignment quality LEDs indicate the alignment quality once the safety light curtain has been switched on.

3.2.4 Status indicators**Overview**

The sender and receiver LEDs indicate the operational status of the safety light curtain.

Sender displays

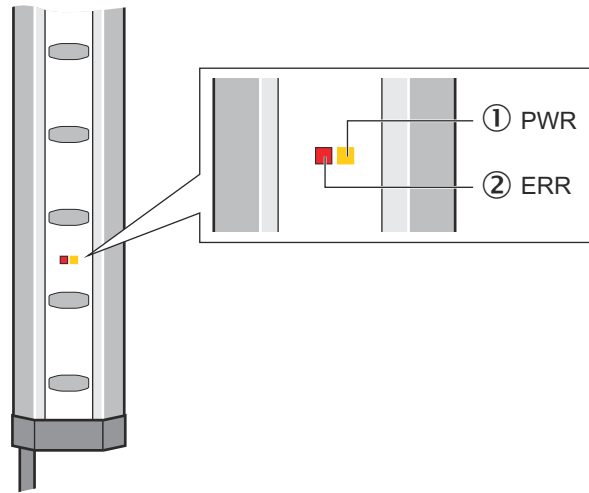

Figure 3: Sender displays

2 LEDs on the sender indicate the operational status:

Position	LED color	Display	Labeling
①	Yellow	Status indicator	PWR
②	Red	Fault indicator	ERR

Receiver displays

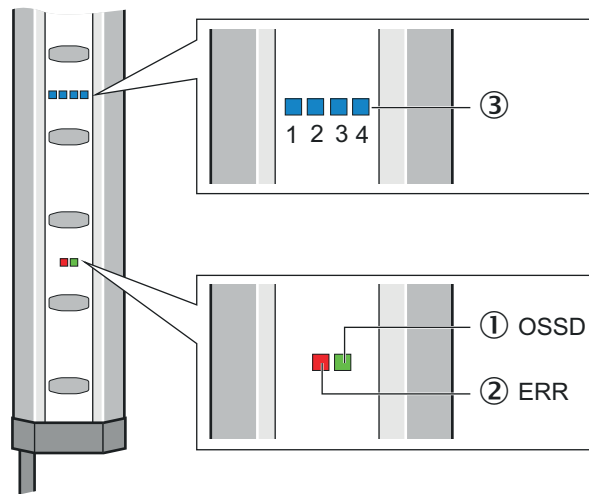

Figure 4: Receiver displays

6 LEDs on the receiver indicate the operational status:

Position	LED color	Display	Labeling
①	Red/green	OSSD status	OSSD
②	Red	Fault indication	ERR
③	Blue	Alignment quality	1, 2, 3, 4

The blue alignment quality light emitting diodes in combination with the red flashing ERR LED also denote faults.

Further topics

- "Diagnostic LEDs", page 48

3.3 Example applications

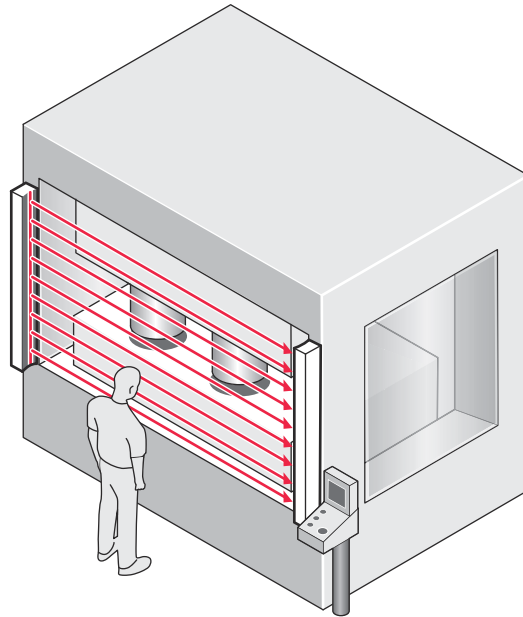

Figure 5: Hazardous point protection

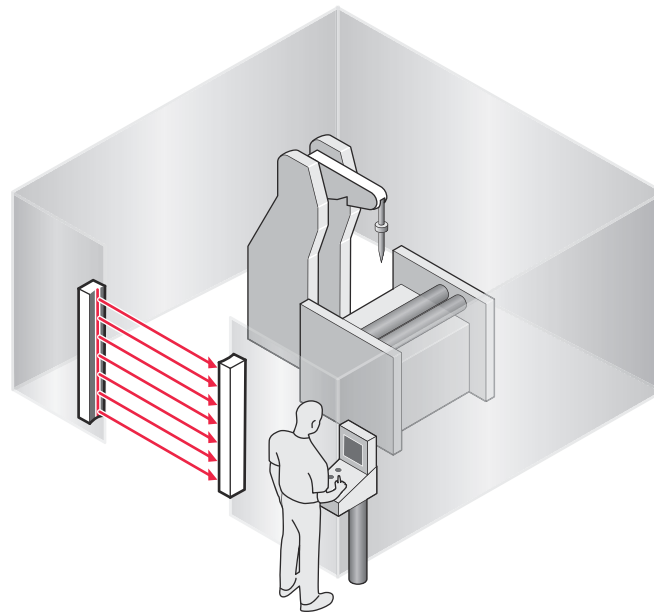

Figure 6: Access protection

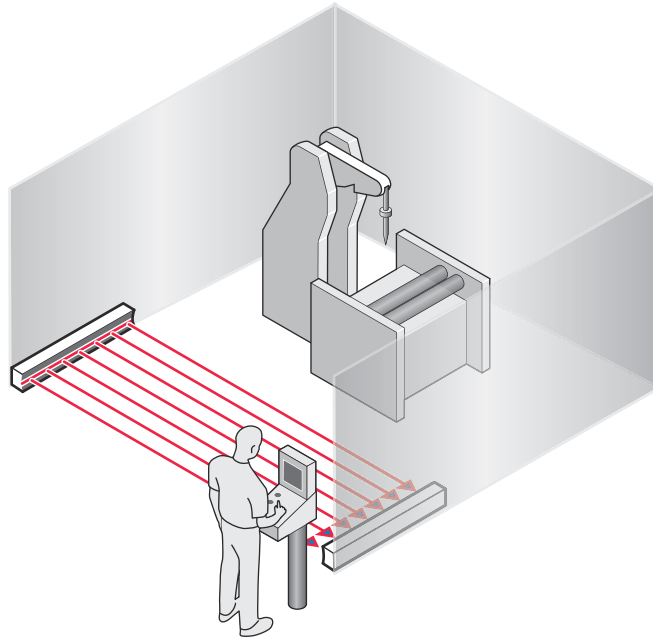

Figure 7: Hazardous area protection

4 Project planning

4.1 Manufacturer of the machine

The manufacturer of the machinery must carry out a risk assessment and apply appropriate protective measures. Further protective measures may be required in addition to the product.

The product must not be tampered with or changed, except for the procedures described in this document.

The product must only be repaired by the manufacturer of the product or by someone authorized by the manufacturer. Improper repair can result in the product not providing the expected protection.

4.2 Operating entity of the machine

Changes to the electrical integration of the product in the machine controller and changes to the mechanical mounting of the product necessitate a new risk assessment. The results of this risk assessment may require the entity operating the machine to meet the obligations of a manufacturer.

The product must not be tampered with or changed, except for the procedures described in this document.

The product must only be repaired by the manufacturer of the product or by someone authorized by the manufacturer. Improper repair can result in the product not providing the expected protection.

4.3 Design

Overview

This chapter contains important information about the design.

Important information



DANGER

Hazard due to lack of effectiveness of the protective device

Persons and parts of the body to be protected may not be recognized in case of non-observance.

- ▶ Make sure that the following construction requirements are met so that the safety light curtain can fulfill its protective function.
 - Sender and receiver must be arranged such that persons or parts of the body are reliably detected when they enter the hazardous area.
 - Reaching under, over, and around as well as moving the safety light curtain must be prevented.
 - Check whether additional safety measures (e.g. restart interlocking) are necessary when it is possible for people to be located between the protection system and the danger point without being detected.



DANGER

Hazard due to lack of effectiveness of the protective device

Persons and parts of the body to be protected may not be recognized in case of non-observance.

- ▶ Make sure that the optical properties of the front screens of the sender and receiver are not changed, e.g., by:
 - beading water, mist, frost, or ice formation. If applicable, remove films or other types of contamination, disconnect the voltage supply of the receiver and then switch it back on.
 - Scratches or damage. Replace the device whose front screen is scratched or damaged.
 - ▶ Make sure that all reflective surfaces and objects maintain a minimum distance from the protective field.
 - ▶ Make sure that no dispersive media (e.g., dust, fog, or smoke) are within the calculated minimum distance from the protective field.
-

Further topics

- ["Mounting", page 32](#)

4.3.1 Scanning range and protective field width

Important information



DANGER

Hazard due to lack of effectiveness of the protective device

Persons and parts of the body to be protected may not be recognized in case of non-observance.

- ▶ The safety light curtain can only be mounted to machines on which the protective field width does not change when the safety light curtain is switched on.
-

Protective field width

The protective field width is the dimension of the light path between sender and receiver. The maximum protective field width is limited by the scanning range.

The protective field width cannot change during operation.

Scanning range

The scanning range limits the maximum protective field width. The protective field width cannot change during operation.

Further topics

- ["Minimum distance to reflective surfaces", page 19](#)
- ["Technical data", page 51](#)

4.3.2 Minimum distance from the hazardous point

Overview

A minimum distance must be maintained between the safety light curtain and the hazardous point. This distance is required to prevent a person or part of their body from reaching the hazardous point before the end of the machine's dangerous state.

Calculation of the minimum distance according to ISO 13855

The calculation of the minimum distance is based on international or national standards and statutory requirements applicable at the place of installation of the machine.

If the minimum distance is calculated according to ISO 13855, then it depends on the following points:

- Machine stopping time (time interval between triggering the sensor function and the end of the machine's dangerous state)
- Response time of the protective device
- Reach or approach speed of the person
- Resolution (detection capability) of the safety light curtain
- Type of approach: orthogonal (at right angles) or parallel
- Parameters specified based on the application

For the USA (scope of OSHA and ANSI), different regulations may apply, e.g.:

- a) Laws: Code of Federal Regulations, Title 29 (CFR 29), Part 1910.217
- b) Standards: ANSI B11.19

Complementary information

More information is available in the ISO 13855 standard and in the Guide for Safe Machinery.

SICK offers a stopping/run-down time measurement service in many countries.

Further topics

- ["Response time", page 53](#)

4.3.2.1 Calculating minimum distance from the hazardous point

Important information



DANGER

Minimum distance from the hazardous point is too small

The dangerous state of the machine may not be stopped or not be stopped in a timely manner due to a minimum distance that is too small.

- ▶ Calculate the minimum distances for the machine in which the safety light curtain is integrated.
- ▶ When mounting the safety light curtain, observe the minimum distance.

Approach

The example shows the calculation of the minimum distance in accordance with ISO 13855 for an orthogonal (right-angled) approach to the protective field. A different calculation may be required depending on the application and the ambient conditions (e.g., for a protective field parallel to or at any angle to the direction of approach or an indirect approach).

1. First, calculate S using the following formula:

$$S = (K \times T) + 8 \times (d - 14 \text{ mm})$$

Where:

- S = minimum distance in millimeters (mm)
- K = approach speed (stepping and/or gripping speed) of a person or a body part (mm/s), e.g. 2,000 mm/s
- T = machine stopping time + response time of the protective device after interruption in the light path in seconds (s)
- d = resolution of the safety light curtain in millimeters (mm)

2. If the result S is ≤ 500 mm, then use the determined value as the minimum distance.
3. If the result S is > 500 mm, then recalculate S with an approach speed of 1,600 mm/s as follows:

$$S = 1,600 \text{ mm/s} \times T + 8 \times (d - 14 \text{ mm})$$
4. If the new value S is > 500 mm, then use the newly determined value as the minimum distance.
5. If the new value S is ≤ 500 mm, then use 500 mm.

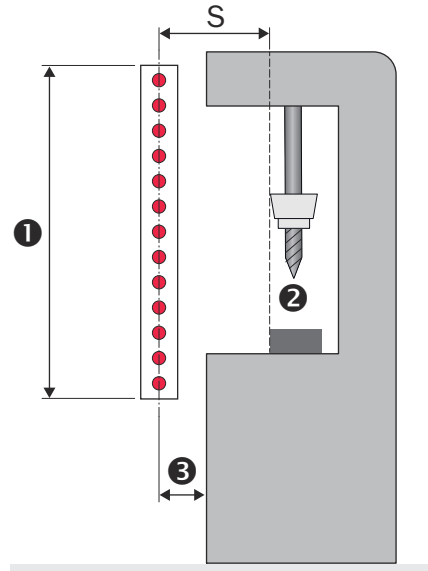

Figure 8: Minimum distance to the hazardous point for orthogonal (rectangular) approach to the protective field

- ① Protective field height
- ② Hazardous point
- ③ Depending on the application and distance, persons must be prevented from standing behind the protective device.

Example calculation

Machine stopping time = 290 ms

Response time after interruption of the light path = 30 ms

Resolution of the safety light curtain = 30 mm

$$T = 290 \text{ ms} + 30 \text{ ms} = 320 \text{ ms} = 0.32 \text{ s}$$

$$S = 2,000 \text{ mm/s} \times 0.32 \text{ s} + 8 \times (30 \text{ mm} - 14 \text{ mm}) = 768 \text{ mm}$$

$S > 500$ mm, therefore:

$$S = 1,600 \text{ mm/s} \times 0.32 \text{ s} + 8 \times (30 \text{ mm} - 14 \text{ mm}) = 640 \text{ mm}$$

4.3.2.2 Taking reach over into account

In accordance with ISO 13855, it must not be possible to defeat the ESPE. If access to the hazardous area by reaching over a protective field cannot be prevented, the height of the protective field and minimum distance of the ESPE must be determined. This is done by comparing the calculated values based on the possible detection of limbs or body parts with the values resulting from reaching over the protective field. The greater value resulting from this comparison must be used.

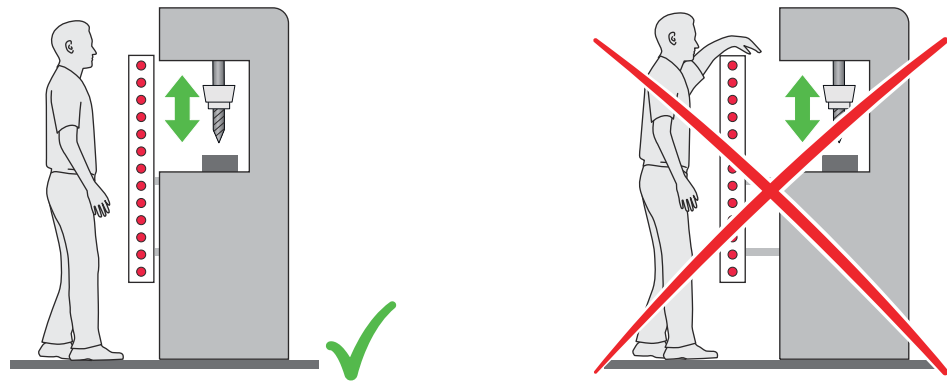

Figure 9: Representation of the accessibility of ESPE by reaching over. Left: Protective field that cannot be reached over. Right: Protective field that can be reached over.

4.3.3 Minimum distance to reflective surfaces

Overview

The light beams from the sender may be deflected by reflective surfaces and dispersive media. This may prevent an object from being detected.

Therefore, all reflective surfaces and objects (e.g. material bins, machine table, etc.) must maintain a minimum distance (a) from the protective field. This minimum distance (a) must be maintained on all sides of the protective field. This applies in horizontal, vertical and diagonal directions as well as at the end of the safety light curtain.

The minimum distance (a) depends on the distance (D) between sender and receiver (protective field width).

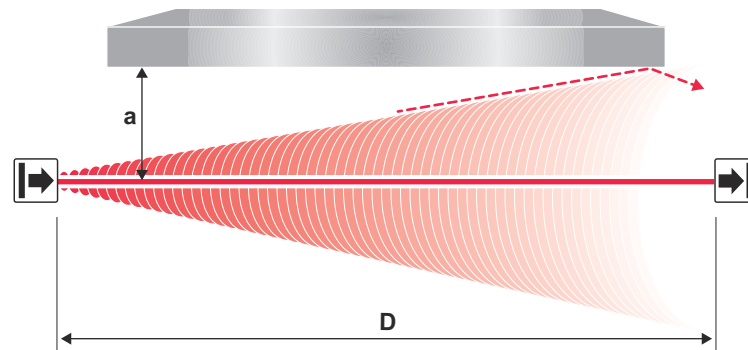

Figure 10: Minimum distance from reflective surfaces

Important information



DANGER

Hazard due to lack of effectiveness of the protective device

Reflective surfaces and dispersive media can prevent persons or parts of the body to be protected from being properly reflected and, therefore, remain undetected.

- ▶ Make sure that all reflective surfaces and objects maintain a minimum distance from the protective field.
- ▶ Make sure that no dispersive media (e.g., dust, fog, or smoke) are within the calculated minimum distance from the protective field.

Determining minimum distance from reflective surfaces

The minimum distance can be determined as follows:

- ▶ Determine the distance between sender and receiver D in meters (m).
- ▶ Read the minimum distance a in millimeters (mm) in the graph or calculate using the respective formula to determine the minimum distance to reflective surfaces:

The minimum distance is dependent on the receiver used.

When using a receiver with a low or medium sensing range

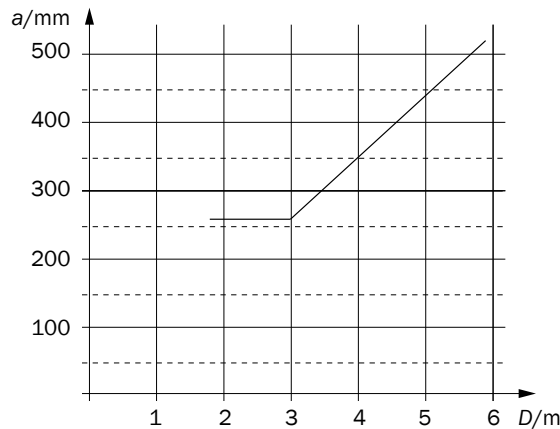

Figure 11: Graph of minimum distance from reflective surfaces

Table 2: Formula for calculating the minimum distance from reflective surfaces

Distance between sender and receiver D in m	Calculating the minimum distance from reflective surfaces a in mm
$D \leq 3 \text{ m}$	$a = 262 \text{ mm}$
$D > 3 \text{ m}$	$a = \tan(5^\circ) \times 1,000 \text{ mm/m} \times D = 87.49 \times 1 \text{ mm/m} \times D$

When using a receiver with a high sensing range

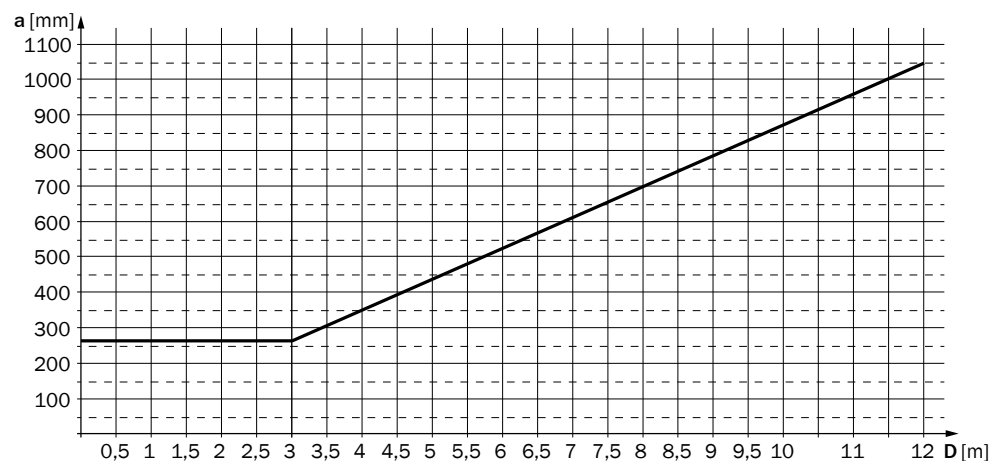

Table 3: Formula for calculating the minimum distance from reflective surfaces

Distance between sender and receiver D in m	Calculating the minimum distance from reflective surfaces a in mm
$D \leq 3 \text{ m}$	$a = 262 \text{ mm}$
$D > 3 \text{ m}$	$a = \tan(5^\circ) \times 1,000 \text{ mm/m} \times D = 87.49 \times 1 \text{ mm/m} \times D$

4.3.4 Protection against interference from systems in close proximity to each other

Overview

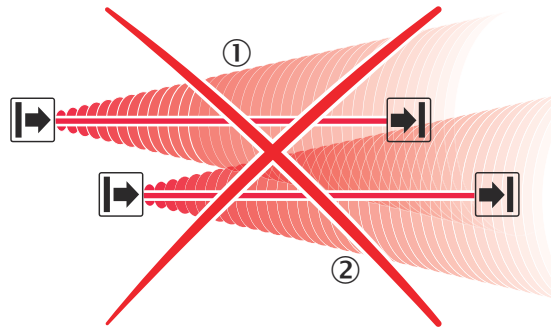

Figure 12: Preventing mutual interference from system ① and system ②

The infrared light beams of the sender of system ① can interfere with the receiver of system ②. This can disrupt the protective function of system ②. This would mean that the operator is at risk.

Important information



DANGER

Hazard due to lack of effectiveness of the protective device

Systems of safety light curtains in close proximity to each other can mutually interfere with each other.

- ▶ Use appropriate measures to prevent systems in close proximity from interfering with each other.



NOTE

The safety light curtain uses a diagnostic function to check whether suitable measures were taken to protect systems in close proximity to each other against interference. If the safety light curtain detects an unsuitable installation situation, it switches to the interlocking state.

Preventing interference between systems in close proximity to each other

The following measures prevent interference from systems in close proximity:

- Reversed direction of transmission for neighboring systems of the same type
- Sufficient distance between two systems of the same type with the same direction of transmission
- Optically opaque partitions (always required if another safety light curtain is installed next to the deTec2 Core Vibes safety light curtain)

Further topics

- ["Using reversed direction of transmission", page 21](#)
- ["Maintaining sufficient distance", page 22](#)

4.3.4.1 Using reversed direction of transmission

Using reversed direction of transmission

The direction of transmission of the system ② can be changed during mounting by switching the positions of the sender and receiver. With reversed direction of mounting, the receiver ② is not affected by the infrared light from the sender ①.

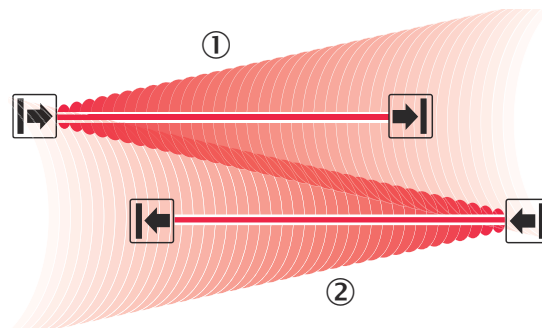

Figure 13: Trouble-free operation due to reversed direction of transmission of system ① and system ②

4.3.4.2 Maintaining sufficient distance

Overview

If systems are installed in the same direction, sufficient distance between the two systems must be maintained.

Determining sufficient distance

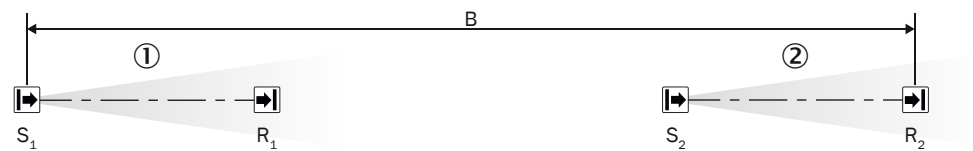

Figure 14: Trouble-free operation with sufficient distance

- S₁** Sender of system ①
- R₁** Receiver of system ①
- S₂** Sender of system ②
- R₂** Receiver of system ②
- B** Minimum distance between sender of the first system and receiver of the second system with the same direction of transmission

► For systems with the same sender direction, consider the following minimum distance B between sender S₁ and receiver R₂:

Element R types: ₂	Minimum distance B between sender S ₁ and receiver R ₂
Receiver with low sensing sensing range 3.8 m	10.5 m
Receiver with medium sensing sensing range 6 m	17 m
Receiver with high sensing sensing range 12 m	34 m

4.3.4.3 Combining sufficient distance and reversed direction of transmission

Overview

To prevent mutual interference in the case of more than two neighboring systems, you can combine the reversed direction of transmission and sufficient distance with each other.

Example: Mounting 3 systems

Figure 15: Fault-free operation by changing the direction and sufficient distance

- S₁** Sender of system ①
R₁ Receiver of system ①
S₂ Sender of system ②
R₂ Receiver of system ②
S₃ Sender from the middle system with opposite direction of transmission
R₃ Receiver of the middle system with opposite direction of transmission
B Minimum distance between sender of the first system and receiver of the second system with the same direction of transmission
- For systems with the same sender direction, consider the following minimum distance B between sender S₁ and receiver R₂:

Element R types: ₂	Minimum distance B between sender S ₁ and receiver R ₂
Receiver with low sensing range 3.8 m	10.5 m
Receiver with medium sensing range 6 m	17 m
Receiver with high sensing range 12 m	34 m

4.4 Integration in electrical control

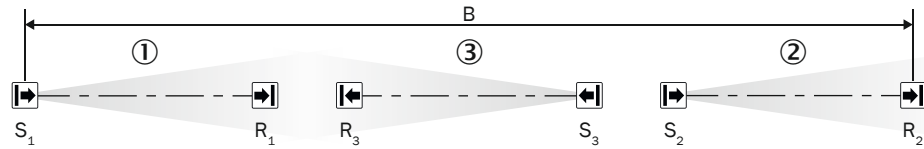
Overview

This chapter contains important information about integration in the electrical control. Information about the individual steps for electrical installation of the device: [see "Electrical installation", page 38.](#)

Important information



DANGER

Hazard due to lack of effectiveness of the protective device

In the case of non-compliance, it is possible that the dangerous state of the machine may not be stopped or not stopped in a timely manner.

- Make sure that the following control and electrical requirements are met so that the product can fulfill its protective function.

Requirements for use

The output signals of the protective device must be analyzed by downstream controllers in such a way that the dangerous state of the machine is ended safely. Depending on the safety concept, signal evaluation is carried out e.g. with safety relays or with a safety controller.

- It must be possible to electrically influence the control of the machine.
- The electrical control of the machine must meet the requirements of IEC 60204-1.

- A restart interlock must be implemented depending on applicable national regulations or required reliability of the safety function. Because the protective device does not have an integrated restart interlock, this must be implemented in the external control, if required.
- When using a safety controller, different signal levels of both OSSDs must be detected depending on applicable national regulations or required reliability of the safety function. The maximum discrepancy time tolerated by the controller must be selected according to the application
- The OSSD1 and OSSD2 output signals must not be connected to each other.
- In the machine controller, the signals of both OSSDs must be processed separately.

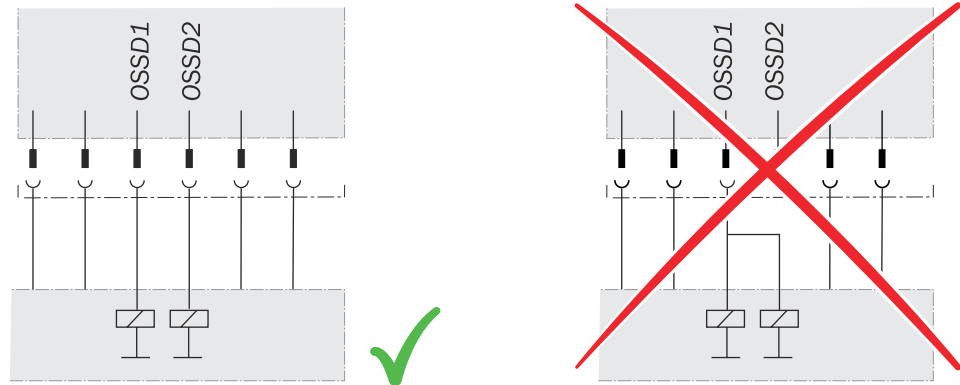

Figure 16: Dual-channel and isolated connection of OSSD1 and OSSD2

- The machine must switch to the safe state at any time if at least one of the two OSSDs switches to the OFF state
- Prevent the formation of a potential difference between the load and the protective device. If you connect loads to the OSSDs (switch outputs) that then also switch if controlled with negative voltage (e.g., electro-mechanical contactor without reverse polarity protection diode), you must connect the 0 V connections of these loads and those of the corresponding protective device individually and directly to the same 0 V terminal strip. In the event of a fault, this is the only way to ensure that there can be no potential difference between the 0 V connections of the loads and those of the corresponding protective device.

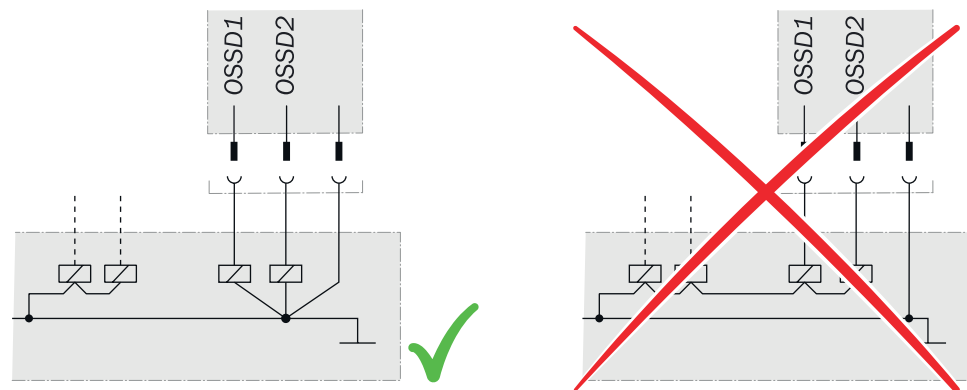

Figure 17: No potential difference between load and protective device

**DANGER**

Hazard due to lack of effectiveness of the protective device

In the case of non-compliance, it is possible that the dangerous state of the machine may not be stopped or not stopped in a timely manner.

Downstream contactors must be positively guided and monitored depending on applicable national regulations or required reliability of the safety function.

- ▶ Make sure that downstream contactors are monitored (external device monitoring, EDM).

**NOTE**

Because the protective device does not have integrated external device monitoring, this must be implemented in the external control, if required.

Requirements for the electrical control of the machine

Both outputs are short-circuit protected to 24 V DC and 0 V. When the protective field is clear, the OSSDs are in the ON state. When a switch-off condition is present (e.g., interruption in the light path), the OSSDs are in the OFF state. In the event of a device fault, at least one OSSD is in the OFF state.

The protective device complies with the rules for electromagnetic compatibility (EMC) for the industrial sector (Radio Safety Class A).

Radio interference cannot be ruled out when used in residential areas.

The following requirements are met:

- The external voltage supply of the protective device must be capable of buffering brief power failures of 20 ms as specified in IEC 60204-1.
- The power supply unit must ensure safe isolation according to IEC 61140 (SELV/PELV). Suitable power supply units are available as accessories from SICK.

Further topics

- ["Accessories", page 58](#)

4.4.1 Restart interlock**Overview**

The restart interlock prevents the machine from automatically starting up, for example after a protective device has responded while the machine is operating or after changing the machine's operating mode.

Depending on the regulations which apply at the place of installation, a restart interlock may be required.

The protective device does not have an internal restart interlock. You must therefore implement a restart interlock externally via the circuitry or the control if needed, e.g. in connection with the SICK RLY3-OSSD2 / RLY3-OSSD3 safety relay.

Principle of operation

Before the machine can be restarted, the operator must reset the restart interlock.

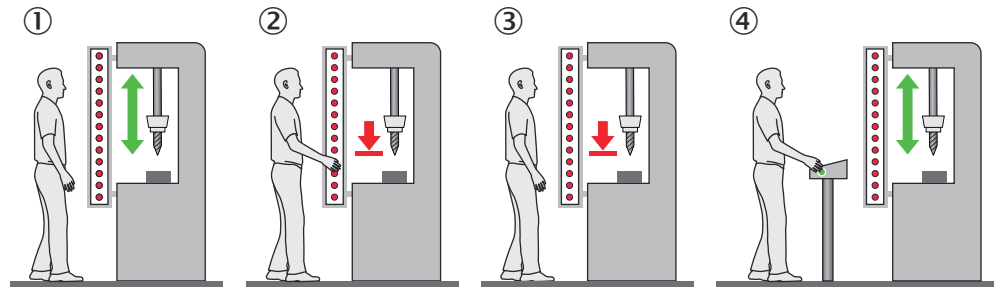

Figure 18: Schematic representation of operation with restart interlock

The dangerous state of the machine (①) is brought to an end if the light path is interrupted (②) and is not re-enabled (③) until the operator presses the reset pushbutton located outside the hazardous area (④). The machine can then be restarted.

Depending on applicable national regulations, a restart interlock must be available if it is possible to stand behind the protective device. Observe IEC 60204-1.

4.4.2 External device monitoring (EDM)

Overview

The external switching elements (external device monitoring, EDM) must be inspected in line with the regulations which apply at the place of installation or the required reliability of the safety function.

External device monitoring (EDM) monitors the status of downstream contactors.

Important information



NOTE

Because the protective device does not have integrated external device monitoring, this must be implemented in the external control, if required.

Prerequisites

- Positively guided contactors are used for shutting down the machine.

4.4.3 Connection diagrams

Connection diagram for RLY3-OSSD2 with restart interlock and external device monitoring

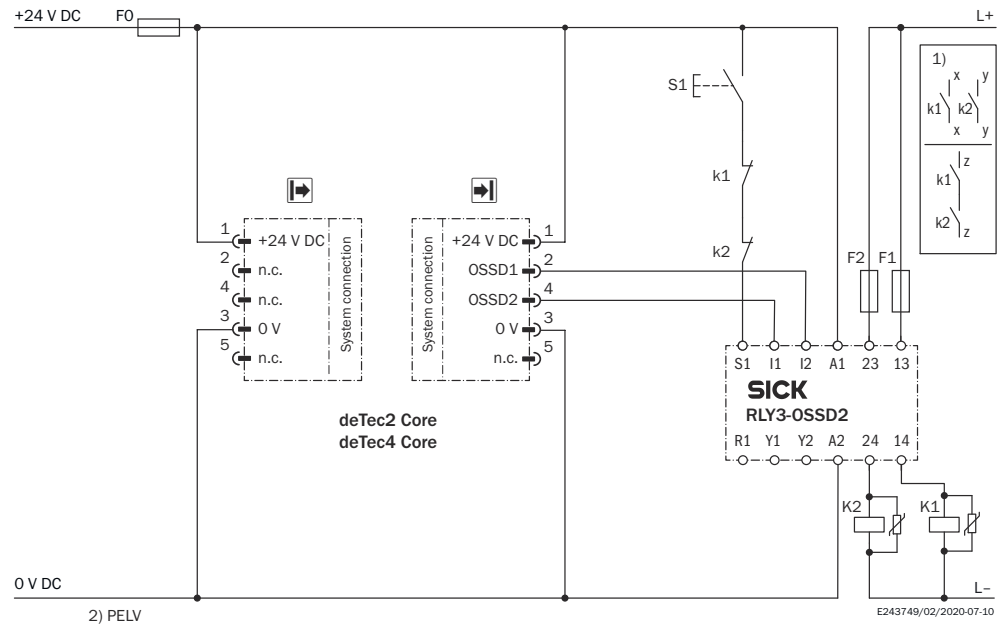

Figure 19: Connection diagram for RLY3-OSSD2 with restart interlock and external device monitoring

- 1) **Output circuits:** These contacts must be incorporated into the control such that the dangerous state is brought to an end if the output circuit is open. For categories 4 and 3, they must be incorporated on dual-channels (x, y paths). Type 2 devices are suitable for use up to PL c. Single-channel incorporation into the control (z path) is only possible with a single-channel control and taking the risk analysis into account.
- 2) SELV/PELV safety extra-low voltage.

- **Task**

Connection of a deTec2 Core Vibes safety light curtain to a RLY3-OSSD2 safety relay. Operating mode: With restart interlock and external device monitoring.

- **Mode of operation**

When the protective field is clear, the OSSD 1 and OSSD 2 outputs carry voltage. The system can be switched on when K1 and K2 are in a fault-free de-energized position. The RLY3-OSSD2 is switched on by pressing S1 (pushbutton is pressed and released). The outputs (contacts 13-14 and 23-24) switch the K1 and K2 contactors on. When the protective field is interrupted, the OSSD 1 and OSSD 2 outputs switch the RLY3-OSSD2 off. Contactors K1 and K2 are switched off.

- **Fault analysis**

Cross-circuits and short-circuits of the OSSDs are recognized and lead to the locking status (lock-out). A malfunction with one of the K1 or K2 contactors is detected. The switch-off function is retained. In the event of manipulation (e.g., jamming) of the S1 pushbutton, the RLY3-OSSD2 will not re-enable the output current circuits.

4.5 Testing plan

The manufacturer of the machine and the operating entity must define all required checks. The definition must be based on the application conditions and the risk assessment and must be documented in a traceable manner.

- ▶ When defining the check, please note the following:
 - Define the type and execution of the check.
 - Define the frequency of the check.
 - Notify the machine operators of the check and instruct them accordingly.

The following checks are often defined in connection with a protective device:

- Check during commissioning and modifications
- Regular thorough check

Check during commissioning and modifications

Before commissioning the machine and after making changes, you must check whether the safety functions are fulfilling their planned purpose and whether persons are being adequately protected.

The following points are often helpful for the definition of the check:

- Does the check have to be completed by qualified safety personnel?
- Can the check be completed by specially qualified and authorized personnel?
- Does the check have to be documented in a traceable manner?
- Can the check be carried out according to a check list? (see ["Checklist for initial commissioning and commissioning", page 63](#))
- Do the machine operators know the function of the protective device?
- Have the machine operators been trained to work on the machine?
- Have the machine operators been notified about modifications on the machine?
- Does the hazardous area being secured have to be checked with a test rod? (see ["Test rod check", page 28](#))

- ▶ Define all guidelines for the check.

Regular thorough check

The thorough check is intended to ensure that the safety functions are fulfilling their planned purpose and whether persons are being adequately protected.

The following points are often helpful for the definition of the check:

- Which check must be carried out and how is it carried out?
 - [Test rod check, page 28](#)
 - [Visual check of the machine and the protective device, page 31](#)
- How often does the check have to be carried out?
- Do the machine operators have to be notified of the check and do they need to be instructed accordingly?

- ▶ Define all guidelines for the check.

4.5.1 Test rod check

Overview

The rod test check is used to check whether the hazardous point is only accessible via the protective field of the safety light curtain and whether the protective device is able to identify each time the hazardous point is approached.

The test is carried out with an opaque test rod whose diameter corresponds to the resolution of the safety light curtain.

Important information

**DANGER**

Use of incorrect test rods

Persons or parts of the body to be protected may not be detected in operation.

- ▶ Only use the included test rod with the diameter specified on the type label of the safety light curtain.
 - ▶ Do not use any test rods with a similar or the same diameter of other safety light curtains.
-

**DANGER**

Hazard due to unexpected starting of the machine

- ▶ Make sure that the dangerous state of the machine is and remains switched off during the check.
 - ▶ Make sure that the outputs of the safety light curtain have no effect on the machine during the check of the components.
-

**DANGER**

Hazard due to lack of effectiveness of the protective device

Persons and parts of the body to be protected may not be recognized in case of non-observance.

Do not operate the machine if the OSSD LED lights up green during the test!

- ▶ If the OSSD LED lights up green during the test even if only briefly, work must stop at the machine.
 - ▶ In this case, the mounting and electrical installation of the safety light curtain must be checked by qualified safety personnel.
-

Prerequisites

- The OSSD LED lights up green.

Approach

1. Move the test rod slowly through the area to be protected (e.g., machine opening), as indicated by the arrow, [see figure 20, page 30](#).
2. Watch the OSSD LED on the receiver during the check. The OSSD LED on the receiver should continuously light up red. The OSSD LED must not illuminate green.

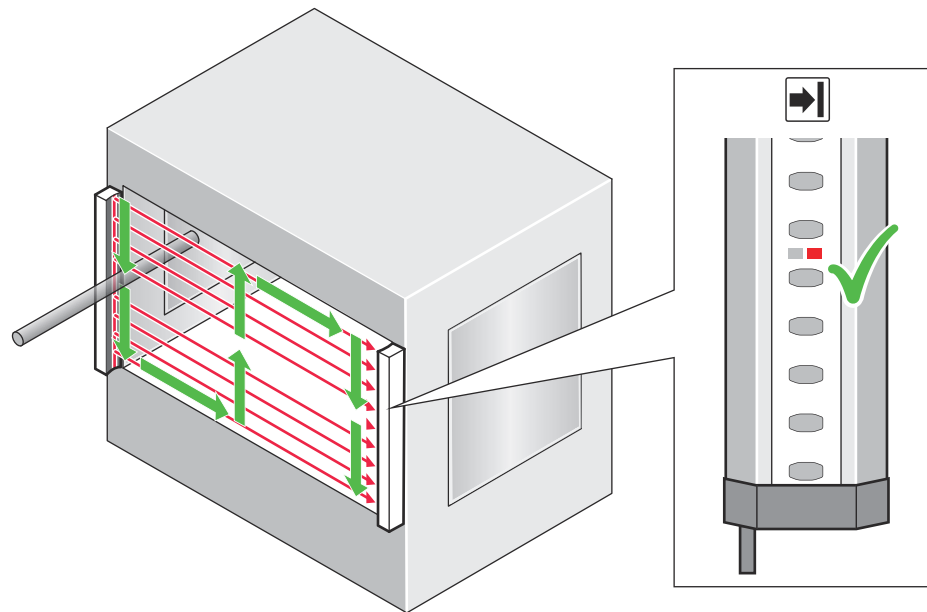

Figure 20: Test rod check: Step 1

3. Then, guide the test rod along the edges of the area to be protected, as indicated by the arrow, [see figure 21](#).
4. Watch the OSSD LED on the receiver during the check. The OSSD LED on the receiver should continuously light up red. The OSSD LED must not illuminate green.

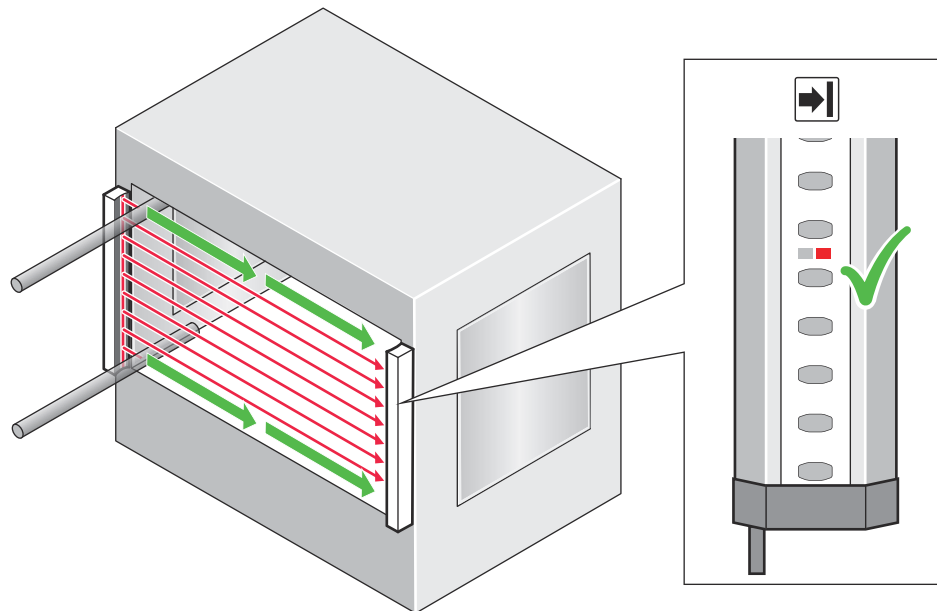

Figure 21: Test rod check: Step 3

5. If one or more deflector mirrors are used, then the test rod should also be guided slowly through the area to be protected directly in front of the deflector mirrors.
6. Watch the OSSD LED on the receiver during the check. The OSSD LED on the receiver should continuously light up red. The OSSD LED must not illuminate green.

4.5.2 Visual check of the machine and the protective device

The following points are often helpful for the definition of the check:

- Has the machine been retrofitted?
- Have machine parts been removed?
- Have modifications been made to the surroundings of the machine?
- Have the protective device or its parts been dismantled?
- Is it possible to enter the hazardous area without being detected?
- Is the protective device damaged?
- Is the protective device severely contaminated?
- Is the front screen contaminated, scratched or destroyed?
- Are there any damaged cables or open cable ends?

If one of the points applies, the machine should be shut down immediately. In this case, the machine and the protective device must be checked by appropriately qualified safety personnel.

5 Mounting

5.1 Safety

Important information



DANGER

Hazard due to lack of effectiveness of the protective device

Persons and parts of the body to be protected may not be recognized in case of non-observance.

- ▶ Only use the sender and receiver of the deTec2 Core Vibes safety light curtain with each other. Do not use the sender or receiver of the deTec2 Core Vibes safety light curtain with components from another safety light curtain or with components from another safety light curtain of the deTec product family.
 - ▶ Only use the brackets described in this document.
 - ▶ Take appropriate measures for vibration damping if vibration and shock specifications exceed the values and test conditions specified in the data sheet, [see "Technical data", page 51](#).
-

Further topics

- ["Design", page 15](#)
- ["Technical data", page 51](#)

5.2 Unpacking

Approach

1. Check the components for completeness and the integrity of all parts.
2. In the event of complaints, contact the responsible SICK subsidiary.

Further topics

- ["Ordering information", page 57](#)

5.3 Installation

Important information



DANGER

Hazard due to lack of effectiveness of the protective device

Persons or parts of the body to be protected may not be recognized or not recognized in time in case of non-observance.

- ▶ Observe the calculated minimum distances for the machine in which the safety light curtain is integrated.
 - ▶ Then, mount the safety light curtain such that it is not possible to reach over, under or around, or to stand behind the safety light curtain, and that the light curtain cannot be repositioned.
-

**DANGER**

Hazard due to lack of effectiveness of the protective device

Persons and parts of the body to be protected may not be recognized in case of non-observance.

- ▶ The safety light curtain can only be mounted to machines on which the protective field width does not change when the safety light curtain is switched on.

**DANGER**

Hazard due to lack of effectiveness of the protective device

Persons and parts of the body to be protected may not be recognized in case of non-observance.

- ▶ The end with the cable connection must point in the same direction for the sender and receiver.

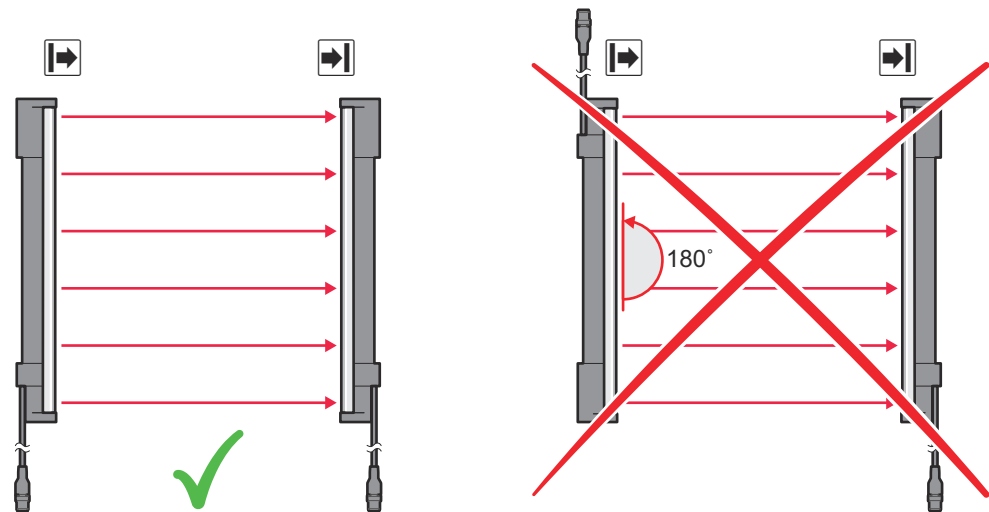

Figure 22: Sender and receiver must not be installed such that they are rotated 180° relative to each other

Prerequisites

- Project planning is completed.
- Assembly is carried out according to the project planning.
- Dangerous condition of the machine is and remains switched off during mounting.
- The outputs of the device do not affect the machine during mounting.

Notes on mounting

- ▶ Mount the sender and receiver on a level surface. (①)

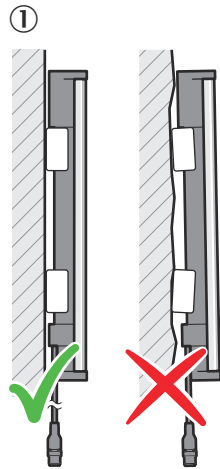

- ▶ Mount the sender and receiver such that a right-angled protective field is established, i.e., when mounted vertically at the same height. (2)
- ▶ For minor adjustments when aligning, the sender and receiver can be adjusted longitudinally in the brackets.

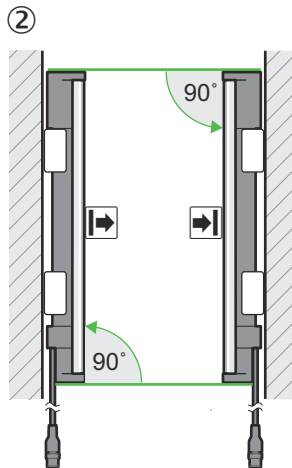

- ▶ Position the brackets near the ends of the housing. For devices with a protective field height > 300 mm, the distance between the bracket and the end of the housing must not exceed 1/4 of the length of the housing. If the device is exposed to strong vibrations during operation, mount the top bracket at a height where the offset in the safety light curtain housing rests on the bracket. (3)

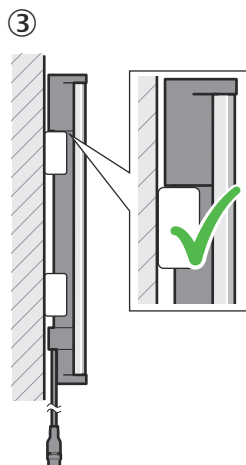

- ▶ Observe the tightening torque details for the particular bracket. Higher torques may damage the bracket. Lower torques do not offer sufficient protection against slipping of the sender and receiver. (④)

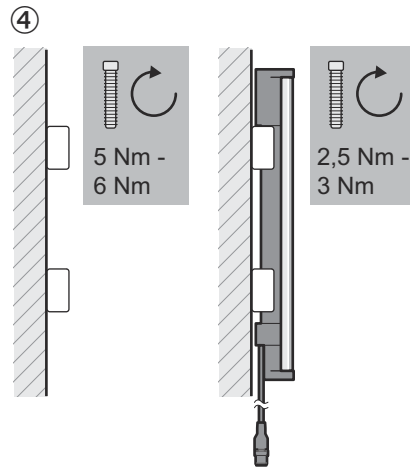

- ▶ Make sure that the sender and receiver are aligned correctly. The optical lens systems of the sender and the receiver must be located opposite one another. (⑤)

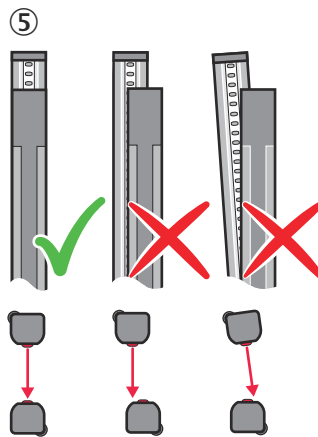

- ▶ If necessary, use a spirit level to check that the components are parallel. (⑥)

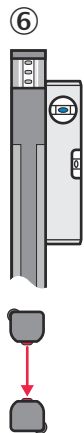

Further topics

- ["Minimum distance from the hazardous point", page 16](#)
- ["Minimum distance to reflective surfaces", page 19](#)

- "Sender and receiver alignment", page 41
- "Alignment with the QuickFix bracket", page 43

5.3.1 Mounting the QuickFix bracket

Overview

2 QuickFix brackets are used to mount the sender and receiver.

The QuickFix bracket consists of 2 parts, which are pushed into each other. The two individual parts are connected with an M5 screw and the housing (sender or receiver) is clamped with form-fit clamping.

The two mounting surfaces for the brackets of the sender or receiver must be parallel and lie in the same plane.

Important information



NOTE

The following should be considered when mounting the QuickFix bracket:

- Select the appropriate length of the M5 screw to prevent any risk of injury from an overrun.
- When selecting the screw length, observe the wall thickness and the depth of the countersunk screw of the QuickFix bracket, [see figure 29, page 58](#)



NOTE

The QuickFix bracket has cable routing. Depending on the installation, the cable routing can make mounting easier.

Mount QuickFix bracket on a machine or profile frame

Table 4: Side and rear mounting with the QuickFix bracket

Mounting method	Description
On the side	Fasten the M5 screw to the machine or profile frame through the QuickFix bracket. A screw nut or threaded hole is required on the machine or profile frame (①).
	Fasten the M5 screw to the QuickFix bracket through the machine or profile frame. A screw nut is required for each QuickFix bracket (②).
	Fasten the M5 screw to the profile frame through the QuickFix bracket. A sliding nut is required on the profile frame (③).
On the back	Fasten the M5 screw to the machine or profile frame through the QuickFix bracket. A screw nut or threaded hole is required on the machine or profile frame (④).

Tightening torque: 5 Nm ... 6 Nm

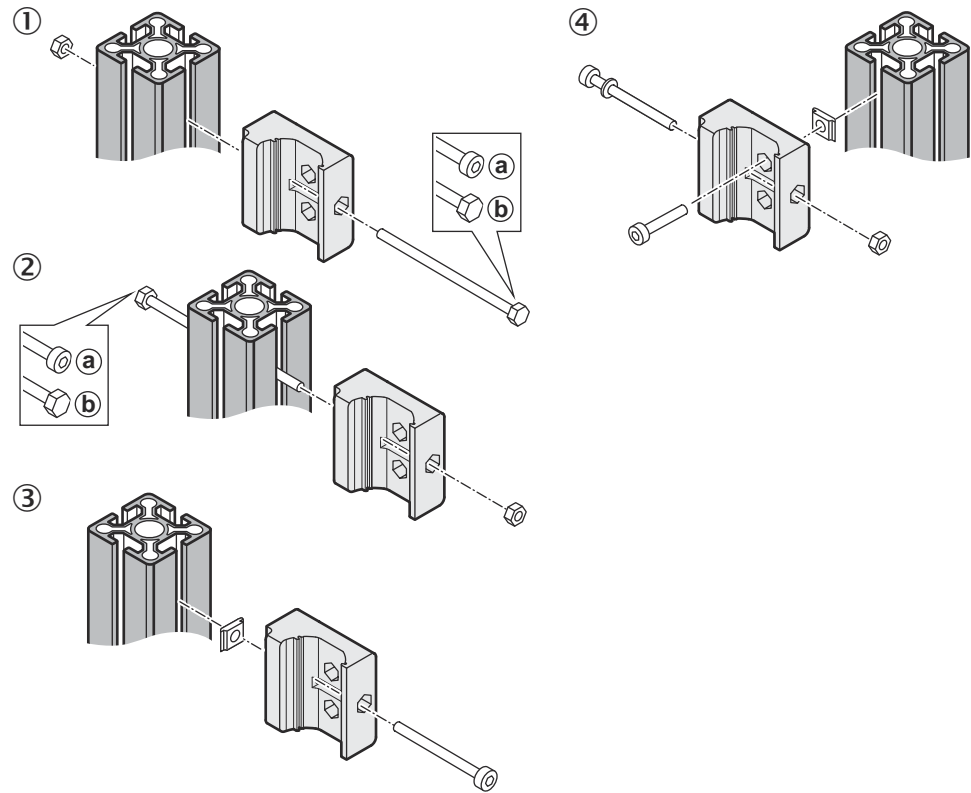

Figure 23: Mounting the QuickFix bracket to a profile

Secure the sender and receiver in the bracket

1. Insert the housing of the sender and receiver into the bracket so that it fits snugly.
2. Secure the position of the sensor and receiver in the bracket using the M5 screw.
Torque: 2.5 Nm to 3 Nm

6 Electrical installation

6.1 Safety

Important information



DANGER

Hazard due to electrical voltage

Hazard due to unexpected starting of the machine

- ▶ Make sure that the machine is (and remains) disconnected from the voltage supply during the electrical installation.
 - ▶ Make sure that the dangerous state of the machine is (and remains) switched off during electrical installation.
 - ▶ Make sure that the outputs of the safety light curtain have no effect on the machine during the electrical installation work.
 - ▶ Use a suitable voltage supply.
-



DANGER

Hazard due to lack of effectiveness of the protective device

The dangerous state may not be stopped in the event of non-compliance.

- ▶ Always connect the two OSSDs separately. The two OSSDs must not be connected to each other.
 - ▶ Connect the OSSDs such that the machine controller processes both signals separately.
-



DANGER

Hazard due to lack of effectiveness of the protective device

The dangerous state may not be stopped in the event of non-compliance.

- ▶ Prevent the formation of a potential difference between the load and the protective device.
-

Prerequisites

- The safety light curtain has been safely integrated into the control system and the electrical system of the machine.
- Mounting has been correctly executed.

Example: Isolated connection of OSSD1 and OSSD2

Figure 24: Dual-channel and isolated connection of OSSD1 and OSSD2

Avoiding any potential difference between load and protective device

If you connect loads to the output signal switching devices (switching outputs) that then also switch if controlled with negative voltage (e.g., electro-mechanical contactor without reverse polarity protection diode), you must connect the 0 V connections of these loads and those of the corresponding protective device separately and also directly to the same 0 V terminal strip. In the event of a fault, this is the only way to ensure that there can be no potential difference between the 0 V connections of the loads and those of the corresponding protective device.

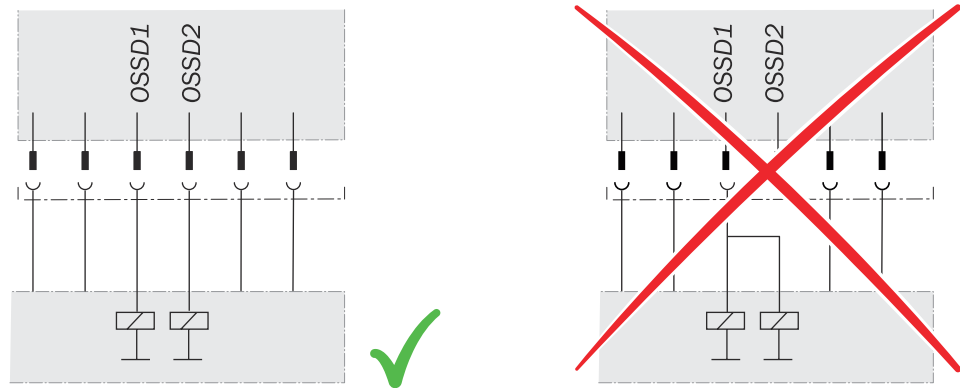
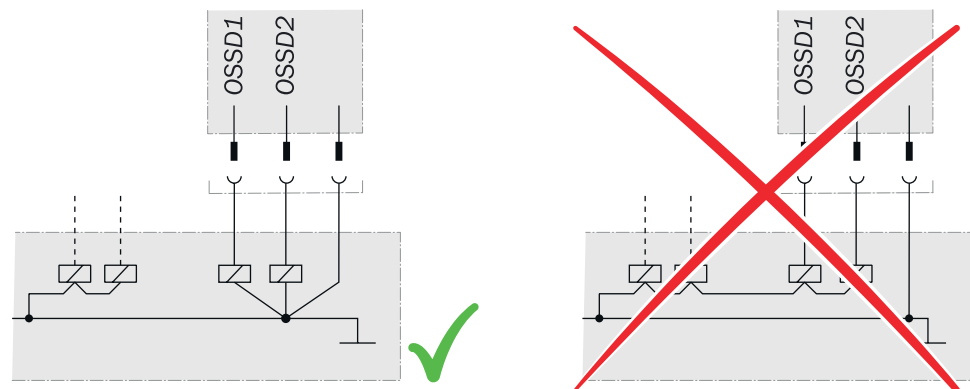

Figure 25: No potential difference between load and protective device

Further topics

- ["Integration in electrical control", page 23](#)
- ["Technical data", page 51](#)

6.2 System connection (M12, 5-pin)

Figure 26: System connection (male connector, M12, 5-pin)

Table 5: System connection pin assignment (male connector, M12, 5-pin)

Pin	Wire color ¹⁾	Sender	Receiver
1	Brown	+24 V DC (voltage supply input)	+24 V DC (voltage supply input)
2	White	Reserved	OSSD1 (output signal switching device 1)
3	Blue	0 V DC (voltage supply input)	0 V DC (voltage supply input)
4	Black	Reserved	OSSD2 (output signal switching device 2)
5	Gray	Not connected	Not connected

¹⁾ Applies to the connecting cables recommended as accessories.

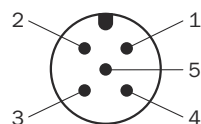
Further topics

- ["Integration in electrical control", page 23](#)

6.3 System connection via connection cable (M12, 5-pin to 8-pin)

An optional connection cable is available to connect the 5-pin system connection to an existing 8-pin female connector. The connection cable can be used to replace an existing TGS safety light curtain with a deTec2 Core Vibes, without having to route new cables.

7 Commissioning

7.1 Overview

Prerequisites

- Project planning is completed.
- Mounting is completed.
- Electrical installation is completed.
- Dangerous state of the machine is and remains off during commissioning.
- The outputs of the device do not affect the machine during commissioning.
- The machine has been inspected and released by qualified safety personnel.
- Protective device works properly.
- The protection function is checked after each change to the machine or to the integration or the operating and boundary conditions of the device.

Further topics

- ["Project planning", page 15](#)
- ["Mounting", page 32](#)
- ["Electrical installation", page 38](#)

7.2 Switching on

Overview

After switching on, the sender and receiver initialize. All LEDs of the sender and receiver briefly light up. After initialization, the receiver displays the alignment quality using four blue LEDs. Once the safety light curtain is aligned (OSSD LED: green), the alignment indicator switches off after a certain period of time, and only the PWR LED of the sender and the OSSD LED of the receiver continue to light up.

In the event of a fault, the red fault LED flashes on the respective device. A red fault LED in combination with the blue LEDs shows the cause of the fault on the side of the receiver.

Further topics

- ["Troubleshooting", page 48](#)

7.3 Sender and receiver alignment

Overview

Once mounting and electrical installation are complete, the sender and receiver must be aligned with each other.

Important information



DANGER

Dangerous state of the machine

- ▶ Make sure that the dangerous state of the machine is (and remains) switched off during the alignment process.
- ▶ Make sure that the outputs of the safety light curtain do not affect the machine during the alignment process.

Further topics

- ["Alignment with the QuickFix bracket", page 43](#)
- ["Indication of the alignment quality", page 43](#)
- ["Diagnostic LEDs", page 48](#)

7.3.1 Aligning the sender and receiver

Important information



DANGER

Dangerous state of the machine

- ▶ Make sure that the dangerous state of the machine is (and remains) switched off during the alignment process.
 - ▶ Make sure that the outputs of the safety light curtain do not affect the machine during the alignment process.
-

Prerequisites

- Sender and receiver have been mounted correctly

Approach

1. Switch on the voltage supply for the safety light curtain.
 2. Roughly align the sender with the receiver: Rotate the sender so that it points toward the receiver.
 3. Align the receiver with the sender: Rotate the receiver so that as many blue alignment quality light emitting diodes as possible light up on the receiver.
 4. If required, align the sender more precisely with the receiver so that as many alignment quality light emitting diodes as possible light up on the receiver.
 5. If required, align the receiver more precisely with the sender so that as many alignment quality light emitting diodes as possible light up on the receiver.
 6. When at least three (preferably four) alignment quality LEDs light up on the receiver, fasten the components in the brackets. Torque: 2.5 Nm ... 3 Nm.
 7. Switch the voltage supply off and then on again.
 8. Check the alignment quality light emitting diodes to make sure that the components are still correctly aligned with each other.
-



NOTE

Once 3 blue alignment quality light emitting diodes light up, alignment is good and availability is stable.

Please note that body parts of objects in the protective field (e.g., hand, tool, AR60 optional laser alignment aid) may impair the function of the alignment quality LEDs. Remove all objects from the protective field to allow the alignment quality to be assessed.

Complementary information

The AR60 optional laser alignment aid can be used to facilitate alignment.

Since the AR60 optional laser alignment aid is positioned in the protective field of the safety light curtain with the adapter, a maximum of two blue alignment quality LEDs light up and the OSSD LED lights up red. To check whether the OSSD LED of the receiver lights up green, remove the AR60 optional laser alignment aid.

Further topics

- ["Indication of the alignment quality", page 43](#)
- ["Mounting", page 32](#)

7.3.2 Alignment with the QuickFix bracket

Prerequisites

- The sender and receiver are mounted with a QuickFix bracket

Alignment with the QuickFix bracket

The QuickFix bracket offers you the following adjustment options for aligning the sender and receiver with each other:

- Shift vertically

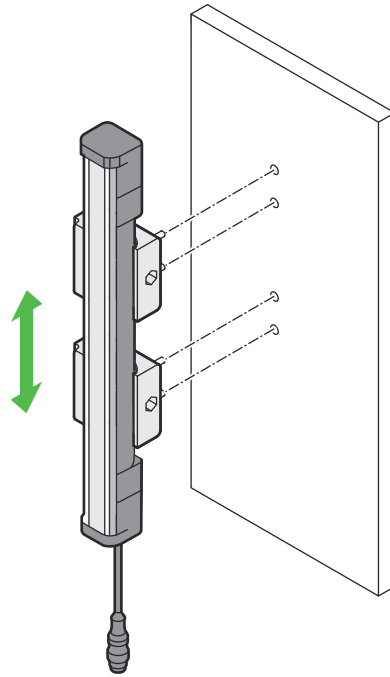

Figure 27: QuickFix bracket: adjust vertically

7.3.3 Indication of the alignment quality

Important information



NOTE

Once 3 blue alignment quality light emitting diodes light up, alignment is good and availability is stable.

Please note that body parts of objects in the protective field (e.g., hand, tool, AR60 optional laser alignment aid) may impair the function of the alignment quality LEDs. Remove all objects from the protective field to allow the alignment quality to be assessed.

Indication of the alignment quality

Table 6: Indication of the alignment quality

LEDs				OSSD	Meaning
Alignment quality light emitting diodes					
1	2	3	4		
○	○	○	○	● Red	Alignment is insufficient or the protective field is interrupted at least partially. The receiver cannot synchronize with the sender.
● Blue	○	○	○	● Red	Alignment is insufficient or the protective field is interrupted at least partially.
● Blue	● Blue	○	○	● Red	Alignment is insufficient or the protective field is interrupted at least partially.
● Blue	● Blue	○	○	● Green	Alignment is not yet sufficient for stable availability.
● Blue	● Blue	● Blue	○	● Green	Alignment is good, stable availability. ¹⁾
● Blue	● Blue	● Blue	● Blue	● Green	Alignment is very good.

○ LED off. ● LED flashes. ● LED illuminates.

- ¹⁾ If the protective fields are very wide, there is a possibility that all four alignment quality LEDs will not light up even when alignment is good.

7.4 Check during commissioning and modifications

The thorough check is intended to ensure that the safety functions are fulfilling their planned purpose and whether persons are being adequately protected.

- ▶ Carry out the checks specified in the test plan of the manufacturer of the machine and the operating entity.

8 Operation

8.1 Regular thorough check

The thorough check is intended to ensure that the safety functions are fulfilling their planned purpose and whether persons are being adequately protected.

- ▶ Carry out the checks specified in the test plan of the manufacturer of the machine and the operating entity.

9 Maintenance

9.1 Regular cleaning

Overview

Depending on the ambient conditions of the safety light curtain, the front screens must be cleaned regularly and in the event of contamination. Static charges can cause dust particles to be attracted to the front screen.

Important information



DANGER

Hazard due to lack of effectiveness of the protective device

Persons and parts of the body to be protected may not be recognized in case of non-observance.

- ▶ Regularly check the degree of contamination on all components based on the application conditions.
 - ▶ Observe the information concerning test rod testing.
-



DANGER

Hazard due to lack of effectiveness of the protective device

Persons and parts of the body to be protected may not be recognized in case of non-observance.

- ▶ Make sure that the optical properties of the front screens of the sender and receiver are not changed, e.g., by:
 - beading water, mist, frost, or ice formation. If applicable, remove films or other types of contamination, disconnect the voltage supply of the receiver and then switch it back on.
 - Scratches or damage. Replace the device whose front screen is scratched or damaged.
 - ▶ Make sure that all reflective surfaces and objects maintain a minimum distance from the protective field.
 - ▶ Make sure that no dispersive media (e.g., dust, fog, or smoke) are within the calculated minimum distance from the protective field.
-



NOTICE

- ▶ Do not use any aggressive cleaning agents.
 - ▶ Do not use any abrasive cleaning agents.
 - ▶ We recommend anti-static cleaning agents.
 - ▶ We recommend the use of anti-static plastic cleaner (SICK part number 5600006) and the SICK lens cloth (SICK part number 4003353).
-

Prerequisites

- Dangerous state of the machine is and remains off during cleaning.
- The outputs of the device do not affect the machine during cleaning.

Approach

1. Remove dust from the front screen using a soft, clean brush.
2. Then wipe the front screen with a clean, damp cloth.
3. Check the position of the sender and receiver after cleaning.
4. Check the effectiveness of the protective device.

Further topics

- ["Test rod check", page 28](#)
- ["Minimum distance to reflective surfaces", page 19](#)

9.2 Regular thorough check

The thorough check is intended to ensure that the safety functions are fulfilling their planned purpose and whether persons are being adequately protected.

- ▶ Carry out the checks specified in the test plan of the manufacturer of the machine and the operating entity.

10 Troubleshooting

10.1 Safety



DANGER

Hazard due to lack of effectiveness of the protective device

Persons and parts of the body to be protected may not be recognized in case of non-observance.

- ▶ Immediately shut the machine down if the behavior of the machine cannot be clearly identified.
- ▶ Immediately put the machine out of operation if you cannot clearly identify or allocate the fault and if you cannot safely remedy the fault.
- ▶ Secure the machine so that it cannot switch on unintentionally.



NOTE

Additional information on troubleshooting can be found at the responsible SICK subsidiary.

10.2 Diagnostic LEDs

10.2.1 Fault indicators

Overview

In the event of a fault, the type of fault is indicated by the LED display on the sender or receiver.

Sender

Position of the LEDs: [see "Sender displays", page 12.](#)

Table 7: Fault indication on the sender

LED		Possible cause	Troubleshooting
PWR	ERR		
○	○	No supply voltage or supply voltage is too low or internal fault	<ul style="list-style-type: none"> ▶ Check the voltage supply, see "Technical data", page 51. ▶ Switch the voltage supply off and back on again. ▶ If the fault persists, replace the sender, see "Ordering information", page 57.
○	● Red	The voltage was too high when operating the sender.	<ul style="list-style-type: none"> ▶ Check the voltage supply, see "Technical data", page 51. ▶ Replace the sender, see "Ordering information", page 57.
● Yellow	● Red	Fault in the supply voltage	<ul style="list-style-type: none"> ▶ Check the voltage supply and the power supply unit, see "Technical data", page 51. ▶ Switch the voltage supply off and back on again. ▶ If the fault continues to persist, replace the defective components, see "Ordering information", page 57.

LED		Possible cause	Troubleshooting
PWR	ERR		
Yellow	Red	The sender identified an internal fault.	<ul style="list-style-type: none"> ▶ Switch the voltage supply off and back on again. ▶ If the fault persists, replace the sender, see "Ordering information", page 57.

○ LED off. LED flashes. ● LED illuminates.

Receiver

Position of the LEDs: see ["Receiver displays"](#), page 12.

Table 8: Fault indication on the receiver

LEDs						Possible cause	Troubleshooting
OSSD	ERR	Alignment quality					
		1	2	3	4		
Red	Red	Blue	○	○	○	An internal fault has occurred.	<ul style="list-style-type: none"> ▶ Switch the voltage supply off and back on again. ▶ If the fault continues to persist, replace the receiver, see "Ordering information", page 57.
Red	Red	○	Blue	○	○	Fault in the supply voltage	<ul style="list-style-type: none"> ▶ Check the voltage supply and the power supply unit, see "Technical data", page 51. ▶ Switch the voltage supply off and back on again. ▶ If the fault continues to persist, replace the receiver, see "Ordering information", page 57.
Red	Red	○	○	Blue	○	The receiver has recognized beams from several senders.	<ul style="list-style-type: none"> ▶ Check the distance to senders of the same design. Make sure that beams from another sender cannot hit the receiver, see "Protection against interference from systems in close proximity to each other", page 21. ▶ Switch the voltage supply off and back on again.
Red	Red	○	○	○	Blue	A fault or unexpected status was identified on the OSSDs of the system connection (e.g., overvoltage, short-circuit to HIGH or short-circuit to LOW, cross-circuit, permissible load capacity exceeded)	<ul style="list-style-type: none"> ▶ Check the system wiring for a fault. Make sure that the OSSDs have been wired correctly, see "Integration in electrical control", page 23. ▶ Switch the voltage supply off and back on again. ▶ If the fault continues to persist, replace the defective components, see "Ordering information", page 57.
Red	Red	○	Blue	○	Blue	Permanent error in the voltage supply.	<ul style="list-style-type: none"> ▶ Replace device, see "Ordering information", page 57.

○ LED off. LED flashes. ● LED illuminates.

11 Decommissioning

11.1 Disposal

Approach

- ▶ Always dispose of unusable devices in accordance with national waste disposal regulations.



Complementary information

SICK will be glad to help you dispose of these devices on request.

12 Technical data

12.1 Data sheet

Table 9: General system data

	Minimum	Typical	Maximum
Protective field height, depending on type	300 mm to 2,100 mm, 150-mm steps		
Resolution (detection capability)	30 mm		
Sensing sensing range, type-specific ¹⁾			
Receiver with low sensing range	3.8 m		
Receiver with medium sensing range	6 m		
Receiver with high sensing range	12 m	15 m	
Minimum distance between sender and receiver			
Receiver with low sensing range	1.8 m		
Receiver with medium sensing range	3.8 m		
Receiver with high sensing range	0 m		
Protection class ²⁾	III (IEC 61140)		
Enclosure rating	IP65 (IEC 60529) IP67 (IEC 60529)		
Supply voltage U_V at the device ^{3) 4)}	19.2 V	24 V	28.8 V
Residual ripple ⁵⁾			± 10%
Synchronization	Optical		
Type	Type 2 (IEC 61496-1)		
Category	Category 2 (ISO 13849-1)		
Performance level ⁶⁾	PL c (ISO 13849-1)		
Safety integrity level ⁶⁾	SIL 1 (IEC 61508)		
SIL claim limit ⁶⁾	SILCL 1 (IEC 62061)		
PFH _D (mean probability of a dangerous failure per hour)	3.1×10^{-8}		
T _M (mission time)	20 years (ISO 13849-1)		
Safe status when a fault occurs	At least one OSSD is in the OFF state.		
Power-up delay of sender and receiver after supply voltage is applied			2 s

- 1) If the protective fields are very wide, there is a possibility that all four alignment quality LEDs will not light up even when alignment is excellent.
- 2) SELV/PELV safety extra-low voltage.
- 3) The external voltage supply must be capable of bridging a brief power failure of 20 ms as specified in IEC 60204-1. Suitable power supply units are available as accessories from SICK.
- 4) A fuse rated maximum 4 A shall be installed in the 24 V DC power supply circuit to the device in order to limit the available current.
- 5) Within the limits of U_V .
- 6) For more detailed information on the exact configuration of your machine, please contact your relevant SICK subsidiary.

Table 10: Technical data for sender

	Minimum	Typical	Maximum
Wavelength of sender		Near-infrared (NIR), invisible	
Weight	Depending on the protective field height, see "Table of weights", page 54		

Table 11: Technical data for receiver

	Minimum	Typical	Maximum
Output signal switching devices (OSSDs)	2 PNP semiconductors, short-circuit protected ¹⁾ , cross-circuit monitored		
Response time	"Response time", page 53		
Duration of OFF state	100 ms		
Switch-on delay		3 × response time	
ON state, switching voltage HIGH (U _{rms}) ²⁾	U _v – 2.25 V	24 V	U _v
OFF state, switching voltage LOW ^{2) 3)}	0 V	0 V	2.0 V
Current-carrying capacity of the OSSDs			300 mA each
Leakage current of the OSSDs			2 mA each
Load capacity			2.2 µF ⁴⁾
Load inductance			2.2 H
Test pulse data ⁵⁾			
Test pulse width		150 µs ⁶⁾	300 µs ⁶⁾
Test pulse rate	3 s ⁻¹	5 s ⁻¹	10 s ⁻¹
Permissible cable resistance ⁷⁾			
Supply cable ⁸⁾			1 Ω
Cable between OSSD and load			2.5 Ω

- 1) Applies to the voltage range between -30 V and +30 V.
- 2) According to IEC 61131-2.
- 3) The specified values are the switching voltage supplied by the safety light curtain. If higher voltages are implanted externally, the maximum value of 2.0 V can be exceeded.
- 4) Applies to devices marked "(Rev. 1)" on the "Ident No." type label entry. For devices not marked "(Rev. 1)", the following applies: Load capacity (maximum) = 30 nF.
- 5) When active, the outputs are tested cyclically (brief LOW). When selecting the downstream controllers, make sure that the test pulses do not result in deactivation when using the above parameters.
- 6) Applies to devices marked "(Rev. 1)" on the "Ident No." type label entry. For devices not marked "(Rev. 1)", the following applies: Test pulse width (typical) = 300 µs; test pulse width (maximum) = 350 µs.
- 7) Limit the individual conductor resistance to the specified values to ensure that the light curtain functions correctly, particularly that a cross-circuit between the outputs is safely detected. (Also observe IEC 60204-1.)
The specified values apply to the total resistance of each wire including contact and connector resistances.
- 8) The supply cable must not be used to connect other loads with the exception of the senders.

Table 12: Operating data

	Minimum	Typical	Maximum
System connection	5-pin M12 male connector		
Length of cable	150 mm		
Cable diameter	4.3 mm		
Cable material	PVC		

	Minimum	Typical	Maximum
Length of cable for connecting cables ¹⁾	"Length of cable", page 54		
Ambient operating temperature ^{2) 3)}	-30 °C		+55 °C
Air humidity (non-condensing)	15%		95%
Storage temperature	-30 °C		+70 °C
Housing cross-section	31 mm × 34 mm, plus bracket, see "Dimensional drawings", page 55		
Vibration resistance ⁴⁾	5 ... 150 Hz, 3,5 mm / 1 g (EN 60068-2-6)		
Shock resistance ⁵⁾	15 g / 6 ms (EN 60068-2-27)		
Class	3M4 (IEC TR 60721-4-3)		

- 1) Maximum permissible conductor resistance must be observed.
- 2) The temperature difference between sender and receiver must not exceed 25 K.
- 3) The cable belonging to the device incl. the associated connection plug must not be flexibly mounted under -25 °C.
- 4) Test conditions per axis: 1 octave/minute, 20 sweeps.
In addition to the required swept-sine tests according to IEC 61496-1, the safety light curtain was subjected to additional tests.
The devices have passed the following tests according to EN 60068-2-6 without modifications:
 - 10 Hz ... 200 Hz: 20 g in each axis
 - 200 Hz ... 400 Hz: 15 g in each axis
 - 200 Hz ... 2 kHz (broadband noise): 10 g for 8 h in each axis
- 5) Test conditions per axis: 200 shocks.
The shock resistance tests were also passed under the following test conditions: 10 g, 16 ms, 1,000 shocks per axis.
In addition to the tests according to IEC 60068-2-27, the safety light curtain was subjected to additional continuous shock tests. The devices passed tests with 1,000,000 shocks and an acceleration of 30 g as well as tests with 100,000 shocks and an acceleration of 100 g without any modifications.

12.2 Response time

Table 13: Response time dependent on the protective field height

Protective field height in mm	Response time in ms
300	10
450	10
600	10
750	11
900	11
1050	11
1200	12
1350	12
1500	13
1650	13
1800	13
1950	14
2100	14

12.3 Power consumption

Table 14: Power consumption for sender and receiver

Protective field height in mm	Typical power consumption for sender in W	Typical power consumption for receiver in W ¹⁾
	Resolution 30 mm	Resolution 30 mm
300	0.82	1.63
450	0.86	1.73
600	0.91	1.82
750	0.96	1.92
900	1.01	2.02
1050	1.06	2.11
1200	1.10	2.21
1350	1.15	2.30
1500	1.20	2.40
1650	1.25	2.50
1800	1.30	2.59
1950	1.34	2.69
2100	1.39	2.78

¹⁾ Power discharged again via the OSSDs depending on the connected OSSD load must be added to the table values.

12.4 Length of cable

Table 15: Maximum lengths of cable for wire cross-section 0.34 mm², copper wire

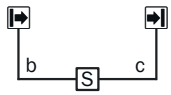
	Single system
Separate connecting cables for sender and receiver	 <p>b ≤ 85 m c ≤ 15 m</p>

S Control cabinet with safety relay or safety controller

12.5 Table of weights

Table 16: Weight of sender and receiver

Protective field height in mm	Weight in g ¹⁾	
	Sender	Receiver
300	290	300
450	430	440
600	570	580
750	700	710
900	840	850
1050	970	980
1200	1110	1120
1350	1240	1250
1500	1380	1390

Protective field height in mm	Weight in g ¹⁾	
	☑ Sender	☑ Receiver
1650	1510	1520
1800	1650	1660
1950	1790	1800
2100	1920	1930

1) Tolerance: ± 50 g.

12.6 Dimensional drawings

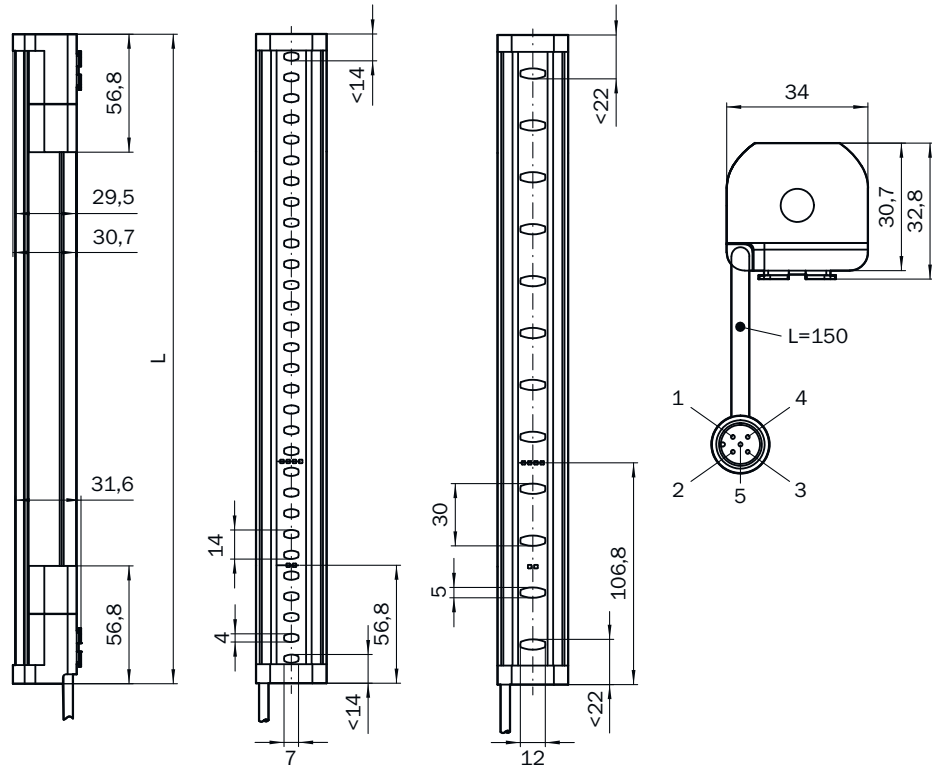

Figure 28: Dimensional drawing of sender and receiver

Table 17: Dimensions based on the protective field height, sender and receiver

Protective field height, nominal in mm	Protective field height, effective = dimension L in mm ¹⁾
300	313
450	463
600	613
750	763
900	913
1050	1063
1200	1213
1350	1362
1500	1512
1650	1662
1800	1812

Protective field height, nominal in mm	Protective field height, effective = dimension L in mm ¹⁾
1950	1962
2100	2112

- ¹⁾ The effective protective field corresponds to the entire length of the housing. The test object defined in the standard IEC 61496-1 is recognized over the entire length of the housing. The limits of the protective field are identical to ends of the housing.

13 Ordering information

13.1 Scope of delivery

Scope of delivery, sender

- Sender

Scope of delivery, receiver

- Receiver
- Test rod with diameter corresponding to the resolution of the safety light curtain
- Safety note
- Mounting instructions
- Operating instructions for download: www.sick.com

14 Accessories

14.1 Brackets

Table 18: Brackets ordering information

Part	Type code	Part number
QuickFix bracket (2x)	BEF-3SHABPKU2	2066048
QuickFix bracket (4x)	BEF-3SHABPKU4	2098710

QuickFix bracket

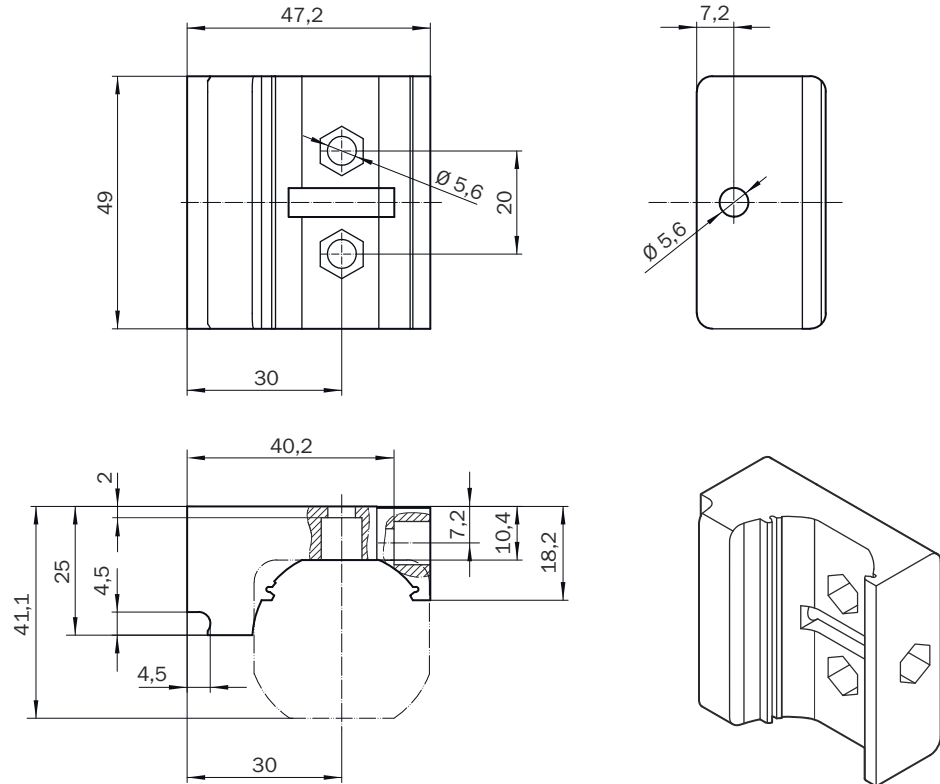

Figure 29: Dimensional drawing of the QuickFix bracket

14.2 Mounting accessories

Table 19: Mounting accessories ordering information

Part	Part number
Alignment tool	4084133

14.3 Connectors

Table 20: Ordering information for M12 connecting cable, 5-pin (0.34 mm²) ¹⁾

Part	Type code	Part number
Female connector, straight, 2 m cable, flying leads	YF2A15-020UB5XLEAX	2095617
Female connector, straight, 5 m cable, flying leads	YF2A15-050UB5XLEAX	2095618

¹⁾ Ambient operating temperature: Down to -30° C with fixed installation.

Part	Type code	Part number
Female connector, straight, 10 m cable, flying leads	YF2A15-100UB5XLEAX	2095619
Female connector, straight, 15 m cable, flying leads	YF2A15-150UB5XLEAX	2095620
Female connector, straight, 20 m cable, flying leads	YF2A15-200UB5XLEAX	2095614
Female connector, straight, 30 m cable, flying leads	YF2A15-300UB5XLEAX	2095621
Female connector, angled, 2 m cable, flying leads	YG2A15-020UB5XLEAX	2095772
Female connector, angled, 5 m cable, flying leads	YG2A15-050UB5XLEAX	2095773
Female connector, angled, 10 m cable, flying leads	YG2A15-100UB5XLEAX	2095774

Table 21: Ordering information, connection cable (replacement of existing devices) ²⁾

Part	Type code	Part number
Connection cable, M12, 5-pin to M12, 8-pin	DSL-1285GM25034KM1	2070987
Connection cable, M12, 5-pin to M26, 7-pin	DSL-6187GM25034KM1	2070988
Connection cable, M12, 5-pin to M26, 12-pin	DSL-6182GM25034KM1	2070989

Table 22: Distributor ordering information

Part	Type code	Part number
T distributor, 5-pin	DSC-1205T000025KM0	6030664

Table 23: Resistance terminal ordering information

Part	Part number
Resistance terminal, 2.15 kΩ	2073807

Table 24: Ordering information for power supply

Part	Type code	Part number
Output 24 V DC, 50 W (2.1 A), voltage supply NEC Class 2, SELV, PELV, input 120 V AC ... 240 V AC	PS50WE24V	7028789
Output 24 V DC, 95 W (3.9 A), voltage supply NEC Class 2, SELV, PELV, input 100 V AC ... 120 V / 220 V AC ... 240 V AC	PS95WE24V	7028790

14.4 Alignment aid

Table 25: Alignment aid ordering information

Part	Part number
AR60 laser alignment aid	1015741
Adapter	4070854

²⁾ Ambient operating temperature: Down to -30 °C with fixed installation

14.5 Cleaning agent

Table 26: Cleaning agent ordering information

Part	Part number
Anti-static plastic cleaner	5600006
Lens cloth	4003353

14.6 Test rods

Table 27: Ordering information, test rods

Part	Part number
Test rod 30 mm	2022602
Test rod holder	2052249

15 Annex

15.1 Conformities and certificates

You can obtain declarations of conformity, certificates, and the current operating instructions for the product at www.sick.com. To do so, enter the product part number in the search field (part number: see the entry in the “P/N” or “Ident. no.” field on the type label).

15.1.1 EU declaration of conformity

Excerpt

The undersigned, representing the manufacturer, herewith declares that the product is in conformity with the provisions of the following EU directive(s) (including all applicable amendments), and that the standards and/or technical specifications stated in the EU declaration of conformity have been used as a basis for this.

- ROHS DIRECTIVE 2011/65/EU
- EMC DIRECTIVE 2014/30/EU
- MACHINERY DIRECTIVE 2006/42/EC

15.1.2 UK declaration of conformity

Excerpt

The undersigned, representing the following manufacturer herewith declares that this declaration of conformity is issued under the sole responsibility of the manufacturer. The product of this declaration is in conformity with the provisions of the following relevant UK Statutory Instruments (including all applicable amendments), and the respective standards and/or technical specifications have been used as a basis.

- Restriction of the Use of Certain Hazardous Substances in Electrical and Electronic Equipment Regulations 2012
- Electromagnetic Compatibility Regulations 2016
- Supply of Machinery (Safety) Regulations 2008

15.2 Note on standards

Standards are specified in the information provided by SICK. The table shows regional standards with similar or identical contents. Not every standard applies to all products.

Table 28: Note on standards

Standard	Standard (regional)
	China
IEC 60068-2-6	GB/T 2423.10
IEC 60068-2-27	GB/T 2423.5
IEC 60204-1	GB/T 5226.1
IEC 60529	GB/T 4208
IEC 60825-1	GB 7247.1
IEC 61131-2	GB/T 15969.2
IEC 61140	GB/T 17045
IEC 61496-1	GB/T 19436.1
IEC 61496-2	GB/T 19436.2
IEC 61496-3	GB 19436.3
IEC 61508	GB/T 20438

Standard	Standard (regional)
	China
IEC 62061	GB 28526
ISO 13849-1	GB/T 16855.1
ISO 13855	GB/T 19876

15.3 Checklist for initial commissioning and commissioning

Checklist for manufacturers or installers for installing electro-sensitive protective device (ESPE)

The details relating to the items listed below must be available no later than when the system is commissioned for the first time. However, these depend on the specific application (the requirements of which must be reviewed by the manufacturer or installer).

This checklist should be retained and kept with the machine documentation to serve as reference during recurring tests.

This checklist does not replace the initial commissioning, nor the regular inspection by qualified safety personnel.

Have the safety rules and regulations been observed in compliance with the directives and standards applicable to the machine?	Yes <input type="checkbox"/> No <input type="checkbox"/>
Are the applied directives and standards listed in the declaration of conformity?	Yes <input type="checkbox"/> No <input type="checkbox"/>
Does the protective device correspond to the required PL/SIL and PFHd in accordance with ISO 13849-1 / IEC 62061 and the required type in accordance with IEC 61496-1?	Yes <input type="checkbox"/> No <input type="checkbox"/>
Is access to the hazardous area or hazardous point only possible through the protective field of the ESPE?	Yes <input type="checkbox"/> No <input type="checkbox"/>
Have appropriate measures been taken to protect (mechanical protection) or monitor (protective devices) any persons or objects in the hazardous area when protecting a hazardous area or hazardous point, and have these devices been secured or locked to prevent their removal?	Yes <input type="checkbox"/> No <input type="checkbox"/>
Are additional mechanical protective measures fitted and secured against manipulation which prevent reaching below, above or around the ESPE?	Yes <input type="checkbox"/> No <input type="checkbox"/>
Has the maximum shutdown and/or stopping time of the machine been measured, specified and documented (at the machine and/or in the machine documentation)?	Yes <input type="checkbox"/> No <input type="checkbox"/>
Has the ESPE been mounted such that the required minimum distance from the nearest hazardous point has been achieved?	Yes <input type="checkbox"/> No <input type="checkbox"/>
Are the ESPE devices properly mounted and secured against manipulation after adjustment?	Yes <input type="checkbox"/> No <input type="checkbox"/>
Are the required protective measures against electric shock in effect (protection class)?	Yes <input type="checkbox"/> No <input type="checkbox"/>
Is the control switch for resetting the protective devices (ESPE) or restarting the machine present and correctly installed?	Yes <input type="checkbox"/> No <input type="checkbox"/>
Are the outputs of the ESPE (OSSDs or safety outputs via the network) integrated according to the required PL/SIL in accordance with ISO 13849-1 / IEC 62061 and does the integration correspond to the circuit diagrams?	Yes <input type="checkbox"/> No <input type="checkbox"/>
Has the protective function been checked in compliance with the test notes of this documentation?	Yes <input type="checkbox"/> No <input type="checkbox"/>
Are the specified protective functions effective at every operating mode that can be set?	Yes <input type="checkbox"/> No <input type="checkbox"/>
Are the switching elements activated by the ESPE, e.g. contactors, valves, monitored?	Yes <input type="checkbox"/> No <input type="checkbox"/>
Is the ESPE effective over the entire period of the dangerous state?	Yes <input type="checkbox"/> No <input type="checkbox"/>
Once initiated, will a dangerous state be stopped when switching the ESPE on or off and when changing the operating mode, or when switching to another protective device?	Yes <input type="checkbox"/> No <input type="checkbox"/>

16 List of figures

1.	Sender and receiver.....	10
2.	Device overview.....	11
3.	Sender displays.....	12
4.	Receiver displays.....	12
5.	Hazardous point protection.....	13
6.	Access protection.....	13
7.	Hazardous area protection.....	14
8.	Minimum distance to the hazardous point for orthogonal (rectangular) approach to the protective field.....	18
9.	Representation of the accessibility of ESPE by reaching over. Left: Protective field that cannot be reached over. Right: Protective field that can be reached over.....	19
10.	Minimum distance from reflective surfaces.....	19
11.	Graph of minimum distance from reflective surfaces.....	20
12.	Preventing mutual interference from system ① and system ②.....	21
13.	Trouble-free operation due to reversed direction of transmission of system ① and system ②.....	22
14.	Trouble-free operation with sufficient distance.....	22
15.	Fault-free operation by changing the direction and sufficient distance.....	23
16.	Dual-channel and isolated connection of OSSD1 and OSSD2.....	24
17.	No potential difference between load and protective device.....	24
18.	Schematic representation of operation with restart interlock.....	26
19.	Connection diagram for RLY3-OSSD2 with restart interlock and external device monitoring.....	27
20.	Test rod check: Step 1.....	30
21.	Test rod check: Step 3.....	30
22.	Sender and receiver must not be installed such that they are rotated 180° relative to each other.....	33
23.	Mounting the QuickFix bracket to a profile.....	37
24.	Dual-channel and isolated connection of OSSD1 and OSSD2.....	39
25.	No potential difference between load and protective device.....	39
26.	System connection (male connector, M12, 5-pin).....	39
27.	QuickFix bracket: adjust vertically.....	43
28.	Dimensional drawing of sender and receiver.....	55
29.	Dimensional drawing of the QuickFix bracket.....	58

17 List of tables

1.	Target groups and selected sections of these operating instructions.....	6
2.	Formula for calculating the minimum distance from reflective surfaces.....	20
3.	Formula for calculating the minimum distance from reflective surfaces.....	20
4.	Side and rear mounting with the QuickFix bracket.....	36
5.	System connection pin assignment (male connector, M12, 5-pin).....	40
6.	Indication of the alignment quality.....	44
7.	Fault indication on the sender.....	48
8.	Fault indication on the receiver.....	49
9.	General system data.....	51
10.	Technical data for sender.....	52
11.	Technical data for receiver.....	52
12.	Operating data.....	52
13.	Response time dependent on the protective field height.....	53
14.	Power consumption for sender and receiver.....	54
15.	Maximum lengths of cable for wire cross-section 0.34 mm ² , copper wire.....	54
16.	Weight of sender and receiver.....	54
17.	Dimensions based on the protective field height, sender and receiver.....	55
18.	Brackets ordering information.....	58
19.	Mounting accessories ordering information.....	58
20.	Ordering information for M12 connecting cable, 5-pin (0.34 mm ²)	58
21.	Ordering information, connection cable (replacement of existing devices)	59
22.	Distributor ordering information.....	59
23.	Resistance terminal ordering information.....	59
24.	Ordering information for power supply.....	59
25.	Alignment aid ordering information.....	59
26.	Cleaning agent ordering information.....	60
27.	Ordering information, test rods.....	60
28.	Note on standards.....	61

Australia

Phone +61 (3) 9457 0600
1800 33 48 02 – tollfree
E-Mail sales@sick.com.au

Austria

Phone +43 (0) 2236 62288-0
E-Mail office@sick.at

Belgium/Luxembourg

Phone +32 (0) 2 466 55 66
E-Mail info@sick.be

Brazil

Phone +55 11 3215-4900
E-Mail comercial@sick.com.br

Canada

Phone +1 905.771.1444
E-Mail cs.canada@sick.com

Czech Republic

Phone +420 234 719 500
E-Mail sick@sick.cz

Chile

Phone +56 (2) 2274 7430
E-Mail chile@sick.com

China

Phone +86 20 2882 3600
E-Mail info.china@sick.net.cn

Denmark

Phone +45 45 82 64 00
E-Mail sick@sick.dk

Finland

Phone +358-9-25 15 800
E-Mail sick@sick.fi

France

Phone +33 1 64 62 35 00
E-Mail info@sick.fr

Germany

Phone +49 (0) 2 11 53 010
E-Mail info@sick.de

Greece

Phone +30 210 6825100
E-Mail office@sick.com.gr

Hong Kong

Phone +852 2153 6300
E-Mail ghk@sick.com.hk

Hungary

Phone +36 1 371 2680
E-Mail ertekesites@sick.hu

India

Phone +91-22-6119 8900
E-Mail info@sick-india.com

Israel

Phone +972 97110 11
E-Mail info@sick-sensors.com

Italy

Phone +39 02 27 43 41
E-Mail info@sick.it

Japan

Phone +81 3 5309 2112
E-Mail support@sick.jp

Malaysia

Phone +603-8080 7425
E-Mail enquiry.my@sick.com

Mexico

Phone +52 (472) 748 9451
E-Mail mexico@sick.com

Netherlands

Phone +31 (0) 30 229 25 44
E-Mail info@sick.nl

New Zealand

Phone +64 9 415 0459
0800 222 278 – tollfree
E-Mail sales@sick.co.nz

Norway

Phone +47 67 81 50 00
E-Mail sick@sick.no

Poland

Phone +48 22 539 41 00
E-Mail info@sick.pl

Romania

Phone +40 356-17 11 20
E-Mail office@sick.ro

Russia

Phone +7 495 283 09 90
E-Mail info@sick.ru

Singapore

Phone +65 6744 3732
E-Mail sales.gsg@sick.com

Slovakia

Phone +421 482 901 201
E-Mail mail@sick-sk.sk

Slovenia

Phone +386 591 78849
E-Mail office@sick.si

South Africa

Phone +27 10 060 0550
E-Mail info@sickautomation.co.za

South Korea

Phone +82 2 786 6321/4
E-Mail infokorea@sick.com

Spain

Phone +34 93 480 31 00
E-Mail info@sick.es

Sweden

Phone +46 10 110 10 00
E-Mail info@sick.se

Switzerland

Phone +41 41 619 29 39
E-Mail contact@sick.ch

Taiwan

Phone +886-2-2375-6288
E-Mail sales@sick.com.tw

Thailand

Phone +66 2 645 0009
E-Mail marcom.th@sick.com

Turkey

Phone +90 (216) 528 50 00
E-Mail info@sick.com.tr

United Arab Emirates

Phone +971 (0) 4 88 65 878
E-Mail contact@sick.ae

United Kingdom

Phone +44 (0)17278 31121
E-Mail info@sick.co.uk

USA

Phone +1 800.325.7425
E-Mail info@sick.com

Vietnam

Phone +65 6744 3732
E-Mail sales.gsg@sick.com

Detailed addresses and further locations at www.sick.com

