

ADDENDUM TO THE OPERATING INSTRUCTIONS

Combination MCS200HW & GMS800 FIDOR

Stand Alone and Container variants

SICK
Sensor Intelligence.

Described product

Combination MCS200HW & GMS800 FIDOR

Manufacturer

SICK AG
Erwin-Sick-Straße 1
79183 Waldkirch
Germany

Production location

SICK AG
Weisserlenstr. 11
79108 Freiburg-Hochdorf
Germany

Legal notes

This work is protected by copyright. The associated rights are reserved by SICK AG. Reproduction of this document or parts of this document is only permissible within the limits of the statutory provisions of copyright law. Any modification, abridgment or translation of this document is prohibited without the express written permission of SICK AG.

The trademarks mentioned in this document are the property of their respective owners.

© SICK. All rights reserved.

Original document

This document is an original document of SICK AG.

Content

1	About this document.....	3
1.1	Information.....	3
1.2	Limitation of liability.....	4
1.3	Purpose of this document.....	4
1.4	Target audience	4
1.5	Further information.....	4
1.6	Other relevant technical documentation/information	5
1.7	Document conventions	6
2	Safety information.....	7
2.1	Intended use	7
2.2	Improper use	7
2.3	Supplementary safety notes.....	8
2.4	Requirements for the qualification of personnel.....	8
2.5	Protective devices	9
2.6	Safety conventions.....	10
2.7	Important warning signs according to ISO 7010.....	11
2.8	Important mandatory symbols according to ISO 7010	12
2.9	Hazard pictograms according to GHS	13
2.10	Warning notices	14
2.11	Additional notes	17
2.12	RoHS directive.....	17
2.13	Warning labels.....	18
3	System description	19
3.1	Gas flow diagram	23
3.2	Technical data	23
3.3	Required instrument air quality.....	23
3.4	Overviews	24
3.4.1	Overview 1 outside	24
3.4.2	Overview 2 - inside - front view	25
3.4.3	Overview 3 - inside - left side view	26
3.4.4	Overview 4 - Inside right side view.....	27
3.5	Heated sample gas line - type ELH.....	28
3.6	MCS200HW.....	29
3.7	Outside display for the overall system	31
3.8	GMS800 FIDOR.....	32
3.9	Inside display - Basic Control Unit	34
3.10	H ₂ Shut-off Valve.....	35
3.11	Filter fan	36
3.12	Instrument air conditioning (option).....	38

3.13	H ₂ monitoring (option).....	39
3.13.1	H ₂ detector (H ₂ monitoring option)	41
3.13.2	H ₂ monitoring system controller- GMC 8022.....	42
3.13.3	Alarm horns (H ₂ monitoring option)	43
3.13.4	More information on the H ₂ monitoring system	43
3.14	Fan monitoring (standard - Stand Alone variant).....	44
3.14.1	Air flow monitor	45
3.14.2	Air flow sensor	46
3.15	Air monitoring system (container option)	46
4	Maintenance.....	47
4.1	HC 150 - H ₂ Gas Sensor.....	47
5	Spare parts list.....	49
6	Disposal.....	51

1 About this document

1.1 Information

NOTE

This document:

- Contains information that is required during the life cycle.
- Must be made available to all those who work with the system.
- Should be read through carefully and it must be ensured that the contents are fully understood before working with the system.

This document (addendum to operating instructions) provides important information on how to handle the combination of the MCS200HW and the GMS800 FIDOR from SICK AG.

Prerequisites for safe work are:

- Compliance with all specified safety notes and handling instructions.
- Compliance with local work safety regulations and general safety regulations for applications and at the installation site of the analyzer system.

This document is intended to be used by qualified personnel and electrical specialists.

Read this document carefully to familiarize yourself with the analyzer system (combination MCS200HW & GMS800 FIDOR) and its functions before commencing any work.

The contents of this document are important throughout the entire life cycle of the analyzer system.

The addendum to operating instructions constitute an integral part of the product and is therefore to be stored in the immediate vicinity of the analyzer system so they remain accessible to staff at all times. If the analyzer system is handed over to a third party, also hand over this document.

The document does not contain all information for operating the analyzer system. Additional information on operation can be found in:

- Circuit diagrams which belong to the system.
- Technical documentation in the scope of delivery.

Other relevant publications of analyzer system components, see [“Other relevant technical documentation/information”](#), page 5.

1.2 Limitation of liability

NOTE

Applicable standards and regulations, the latest state of technological development, and our many years of knowledge and experience have all been taken into account when assembling the data and information contained in this document.

The manufacturer accepts no liability for damage caused by:

- Non-observance of analyzer system documentation (e.g. system description).
- Improper use.
- Use of untrained staff.
- Non-compliance with notes and regulations.
- Unauthorized conversion.
- Unauthorized mounting and installation.
- Unauthorized technical and other changes.
- Use of unauthorized spare parts, wear and tear parts, and accessories.
- Unauthorized changes, adjustments, and/or manipulations of software.
- Failure to perform and document regular maintenance work.

The actual scope of delivery may differ from the features and illustrations shown here where special variants are involved, if optional extras have been ordered, or as a result of the latest technical changes.

1.3 Purpose of this document

This document describes the Combination MCS200HW & GMS800 FIDOR and provides information for the entire life cycle of the analyzer system.

1.4 Target audience

This document is intended for qualified persons (skilled personnel, electrical specialists) who work with or on the Combination MCS200HW & GMS800 FIDOR.

1.5 Further information

Special local conditions

The local laws, regulations, technical rules and internal company operating instructions at the usage site must be observed.

Storage of documents

The system description is an integral part of the product. Store the description in the immediate vicinity of the analyzer system so it remains accessible to staff at all times.

Store this document and other relevant technical documents/information (technical documentation) throughout the entire life cycle to:

- Look up information.
- Hand it over to new system operators/new specialist personnel.
- If the analyzer system is passed on to a third party, this document should be handed over with it in its entirety.

1.6 Other relevant technical documentation/information

- Circuit diagrams
- Technical documentation on analyzer system, for example:
 - Signal lists
 - Drawings
- Operating instructions/Data sheets/Technical documentation for system components:

Component	Manufacturer	Variant Stand Alone	Variant Container
MCS200HW multi-component analyzer system	SICK	✓	✓
SFU gas sampling unit	SICK	✓	✓
GMS810/811 FIDOR	SICK	✓	✓
BCU control unit (inside display)	SICK	✓	✓
Heated sample gas line type ELH	SICK	✓	✓
I/O module	SICK	✓	✓
Condensate tank user manual	SICK	(✓)	(✓)
Capacitive proximity sensor	SICK	(✓)	(✓)
GMC 8022 controller (H ₂ monitoring evaluation unit)	Bieler&Lang	(✓)	(✓)
HC 150 ex-detector (H ₂ detector)	Bieler&Lang	(✓)	(✓)
Compressed air preparation	Donaldson	(✓)	(✓)
Pressure control station instrument air	Festo	(✓)	(✓)
Ethernet switch	Phoenix Contact	✓	✓
STEP-PS voltage supply	Phoenix Contact	✓	✓
Filter fan	Rittal	✓	✓
Air flow sensor	Seikom	✓	(✓)
Air flow monitor	Seikom	✓	(✓)
CANopen controller	Wago	✓	✓
Container ventilation monitoring	N/A		✓

- (✓) = optional

1.7 Document conventions

✂ Required tools

▶ Action to be taken

↪ Result of action

[] Alphanumeric characters in brackets show the equipment ID as used in circuit diagrams (EPLAN), for example [-GQ1].



Reference to another document

- Title.
-

- All measurement units used in this document are metric.
- Subject to change without notice.
- Illustrations may differ from the actual design.

2 Safety information

2.1 Intended use

The Combination MCS200HW & GMS800 FIDOR is used for continuous gas analysis. An MCS200HW analyzer and an FIDOR analyzer are installed together in an analyzer cabinet for this purpose.

The sample gas flows from the gas sampling probe into the two analyzers (MCS200HW and FIDOR) via heated sample gas lines. The sample gas flows out of the analyzer system via the gas outputs. The gas outputs must be protected from frost and must not clog so that all gases always flow out safely and no dangerous situations arise.

There are two constructional variants of the Combination MCS200HW & GMS800 FIDOR:

- **Stand Alone variant**

This system consists of an analyzer cabinet and its peripheral components.

- **Container variant**

This system consists of one or several analyzer cabinets which are installed in a container (analyzer shelter) along with the associated peripheral components.

Since a FIDOR analyzer uses hydrogen (H₂) as fuel, an H₂ shut-off valve and an H₂ volume flow limiter (choke) must be installed.

In addition, at least one of the following safety devices must be installed and active:

- Fan monitoring (standard in Stand Alone variant).
- H₂ monitoring with detector, controller and alarm horns.

ACHTUNG

The operating entity of the combination MCS200HW & GMS800 FIDOR must readjust the analyzers at the installation site before commissioning.

- ▶ The adjustment instructions contain the operating instructions of the individual analyzers.

2.2 Improper use

Any use outside the specified areas, in particular use outside the technical specifications and in contradiction to the requirements related to the intended use, is considered improper use.

- The device must not be used in explosion-hazardous areas or under extreme ambient conditions.
- Any use of accessories not specifically approved by SICK AG is at your own risk.



WARNING

Danger due to improper use

- Any improper use can result in dangerous situations.
- ▶ The analyzer system should be used only in line with its intended use specifications.
- ▶ All information in this system description must be observed.

2.3 Supplementary safety notes

- ▶ Please read this system description through carefully and observe all the safety notes and information before working on the Combination MCS200HW & GMS800 FIDOR.
- ▶ Only qualified persons from the relevant departments are permitted to work on the Combination MCS200HW & GMS800 FIDOR.
- ▶ Follow operating processes.
- ▶ Follow local regulations.
- ▶ Follow all applicable local laws, technical rules and internal company operating instructions which apply at the usage site of the analyzer system.
- ▶ Only authorized persons are permitted to access the Combination MCS200HW & GMS800 FIDOR.

2.4 Requirements for the qualification of personnel

The quality requirements on personnel are as follows:

Skilled or qualified personnel have the specialist training, skills, and experience, as well as knowledge of the relevant regulations, to be able to perform tasks assigned to them and to detect and avoid any potential dangers independently.

Electricians have the specialist training, skills, and experience, as well as knowledge of the relevant standards and provisions, to be able to carry out work on electrical systems and to detect and avoid any potential dangers independently.

2.5 Protective devices

Stand Alone variant

Safety device in/on analyzer cabinet	Stand Alone variant	
	Standard	Option
Fan monitoring	✓	
H ₂ concentration monitoring		✓
H ₂ volume flow limiter (choke)	✓	
H ₂ solenoid valve for stopping H ₂ feed in case of danger	✓	

Container variant

Safety device	Container variant			
	In/On analyzer cabinet		In/On container ¹⁾	
	Standard	Option	Standard	Option
Fan monitoring		✓	✓ ²⁾	
H ₂ concentration monitoring		✓		✓ ³⁾
H ₂ volume flow limiter (choke)	N/A		✓	
H ₂ solenoid valve for stopping H ₂ feed in case of danger	N/A		✓	

¹⁾ If the safety devices are not present in the container (e.g. when retrofitting an MCS200HW&GMS800 FIDOR), the analyzer cabinet is treated as a Stand Alone variant.

²⁾ If no fan monitoring system or no ventilation is installed in the container, e.g. due to the ambient conditions at the installation site (toxic atmospheres, climatic conditions), an H₂ concentration monitoring system is absolutely mandatory.

³⁾ Also when using a fan with monitoring system in the container, we recommend installing an H₂ concentration monitoring system.

Alarm

Prerequisite: H₂ monitoring system is installed.

An alarm horn with integrated flashing light signals the following alarm thresholds:

- Horn tone at an H₂ concentration from 20% of the LEL at the measurement site.
- Additional flashing light at an H₂ concentration of over 25% of the LEL at the measurement site.

Alarm type	Alarm threshold	Unit	Behavior of alarm horns	Behavior of system
Pre-alarm	20	% of LEL	Horn tone	Alarm signal possibly transmitted#
Alarm	25	% of LEL	Additional flashing light	Shut-off valve stops H ₂ supply Alarm signal possibly transmitted



For more information:

- Circuit diagram

2.6 Safety conventions

Safety symbols on the system and system components, as well as safety notes and safety labels, correspond to the current guidelines and standards.

The safety conventions for signal words used in this document conform to ANSI Z535.



DANGER

Refers to a hazard with a high level of risk that will result in serious injury or death if not avoided.



WARNING

Refers to a hazard with a medium level of risk that may result in serious injury or death if not avoided.



CAUTION

Refers to a hazard with a low level of risk that will result in a minor or moderate injury if not avoided.











NOTICE

Refers to possible damage to property and materials.







Note

Important information and useful notes.

2.7 Important warning signs according to ISO 7010









Symbol	Meaning
	General warning sign
	Materials with explosion risk warning
	Hazardous electrical current warning
	Suspended load warning
	Toxic substances warning
	Hot surface warning
	Flammable materials warning
	Corrosive substances warning
	Oxidizing materials warning
	Gas bottle warning

2.8 Important mandatory symbols according to ISO 7010

Symbol	Meaning
	Observe instructions for use
	Put on eye protection
	Put on foot protection
	Put on hand protection
	Put on face protection.
	Put on head protection
	Put on breathing protection

2.9 Hazard pictograms according to GHS

GHS = Global Harmonized System of Classification, Labelling and Packaging of Chemicals.

Symbol	Hazard class
	Risk of explosion
	Flammable
	Flammable (oxidizing) effect
	Gas under pressure
	Corrosive
	Poisonous
	Irritating
	Risk to health
	Hazardous to the aquatic environment

2.10 Warning notices

HINWEIS

Also observe the warning notes and safety information in the operating instructions of the system components.



DANGER

Live parts

Risk of serious injuries or fatalities.

- ▶ Work on electrical systems must only be performed by qualified electricians.
- ▶ Never disconnect or remove the protective conductor in the analyzer system.
- ▶ Never disconnect or remove any protective conductors in the mains cable.
- ▶ Always ground before operating the analyzer system.
- ▶ If hazard-free operation is no longer possible, the system/component must be:
 - ▶ Decommissioned
 - ▶ Labeled as dangerous
 - ▶ Secured against being switched back on



DANGER

Toxic gases

Risk of serious injuries or fatalities due to poison, suffocation and respiratory problems. Risk of serious eye or skin injuries.

- ▶ Only operate analyzer system in sufficiently-ventilated rooms.
- ▶ Safely guide sample gas and other media out of the analyzer system.
- ▶ Before opening fittings of sample gas lines or components in the sample gas path, flush the gas paths with neutral gas for a sufficient amount of time.
 - ▶ Flush sample gas paths, for example with N₂ or instrument air.
- ▶ Before each re-commissioning process, run a leak test, for example with leak detection spray or pressure and leak management devices.
- ▶ Perform leak tests on a regular basis.
- ▶ Check fan monitoring system for proper function and error signaling on a regular basis.
- ▶ Check whether mountings, connection cable and fittings are loose on a regular basis.
- ▶ Observe notes of the operating entity of the system.
- Toxic gases could be present at the installation site and in the probe if there are leaks:
 - ▶ Put on personal protective equipment (hand protection, eye protection).
 - ▶ Put on suitable eye protection.
 - ▶ Use portable gas warning devices.
 - ▶ Put on protective clothing if necessary.

 **DANGER****Risk of explosion due to hydrogen leaks**

Risk of serious injuries or fatalities due to explosion.

- ▶ Before opening fittings of H₂ lines and components in the H₂ gas path:
 - ▶ Block H₂ supply to the system.
 - ▶ Flush H₂ gas paths with neutral gas (inert gas) for a sufficient amount of time.
 - ▶ Never flush **H₂ lines with instrument air** ; only use inert gas N₂.
- ▶ Before each re-commissioning process, run a leak test, for example with leak detection spray or pressure and leak management devices.
- ▶ Perform leak tests on a regular basis.
- ▶ Check fan monitoring system for proper function and error signaling on a regular basis.
- ▶ Check whether mountings, connection cable and fittings are loose on a regular basis.

 **DANGER****Toxic gases if the event of overpressure in the gas channel and leaks in system**

Risk of serious injuries or fatalities due to poison, suffocation and respiratory problems.

Risk of damage to eyes and skin.

- **If there is overpressure in the channel**, gas flows out when the **probe** is opened.
- **During a filter change**, toxic gas can flow out of the **probe**.
- **If there are leaks**, toxic gas can be present in the **analyzer cabinet**.
- **If there are leaks**, toxic gas can be present in the **probe**.
- ▶ Use a portable gas warning device to quickly detect hazards.
- ▶ Before working on the system, take suitable protection and safety measures.
- ▶ Put on personal protective equipment:
 - ▶ Put on breathing protection.
 - ▶ Put on hand protection.
 - ▶ Put on eye protection.
- ▶ When working on the gas sampling probe, block the probe off from the process, or only work with the probe when the process is not running.
- ▶ Carefully open the probe cover and air out the housing with ambient air.



WARNING

Poisonous gas in condensate tank

Risk of serious injuries or fatalities due to poison, suffocation and respiratory problems.

Risk of serious damage to eyes and skin.

- The condensate tanks and lines contain sample gas, condensate and condensate deposits which could be poisonous and corrosive.
- ▶ Do not breath in vapors.
- ▶ Avoid contact with eyes.
- ▶ Protect eyes.
- ▶ Put on personal protective equipment during drainage and disposal:
 - ▶ Put on hand protection.
 - ▶ Put on eye protection.
 - ▶ Put on face protection.
 - ▶ Put on protective clothing if necessary.
 - ▶ Put on breathing protection if necessary.



WARNING

Corrosive and poisonous condensate (poisonous, corrosive) in condensate tank

Risk of damage to eyes and skin.

Risk of serious injuries or fatalities due to poison, suffocation and respiratory problems.

- The condensate tanks contain condensate and condensate deposits which could be poisonous and corrosive.
- ▶ Do not breath in vapors.
- ▶ Avoid contact with eyes.
- ▶ Protect eyes.
- ▶ Only open condensate tank in well-ventilated rooms.
- ▶ Always dispose of condensate and carried sample gas safely and in line with local regulations.
- ▶ Observe applicable occupational health and safety measures.
- ▶ Put on personal protective equipment during drainage and disposal:
 - ▶ Put on hand protection.
 - ▶ Put on eye protection.
 - ▶ Put on face protection.
 - ▶ Out on protective clothing if necessary.
 - ▶ Put on breathing protection if necessary.

**WARNING****Hot surfaces**

Risk of serious burns.

- ▶ Avoid contact with hot surfaces.
- ▶ Let components cool off before working on them.
- ▶ Put on personal protective equipment.
 - ▶ Put on hand protection.
 - ▶ Put on protective clothing if necessary.
- ▶ Protect system from unauthorized access.

2.11 Additional notes

NOTICE**System warranty**

No warranty claims will be accepted if:

- ▶ The safety notes and measures in this document are not observed.
- ▶ Parts or components of the Combination MCS200HW & GMS800 FIDOR have been installed, mounted or modified without authorization.
- ▶ The Combination MCS200HW & GMS800 FIDOR has been altered or modified.
- ▶ The software has been modified, customized, and/or tampered with without authorization.
- ▶ Maintenance, repair and replacements were not done correctly or were not documented correctly.

NOTICE**Damage to the system.**

Damage to the system components or parts can lead to malfunctions of the Combination MCS200HW & GMS800 FIDOR as a whole.

- ▶ In the event of transport damage:
 - ▶ Immediately document and report damages.
 - ▶ Inform the next superior.
 - ▶ Contact SICK Service.

2.12 RoHS directive

This product has been designed for specific applications in large industrial plants according to the current RoHS directive of the EU, and must therefore only be used in such plants.

The product is neither suitable nor approved for use outside of these plants. SICK therefore cannot provide any warranty or accept any liability whatsoever for such use.

2.13 Warning labels

Warning - dangerous gases



DANGER

Warning labels are missing or illegible

Risk of serious injuries or fatalities.

- Warning label must always be legible.
- ▶ Do not cover or remove warning labels.
- ▶ Immediately replace missing or damaged warning labels.

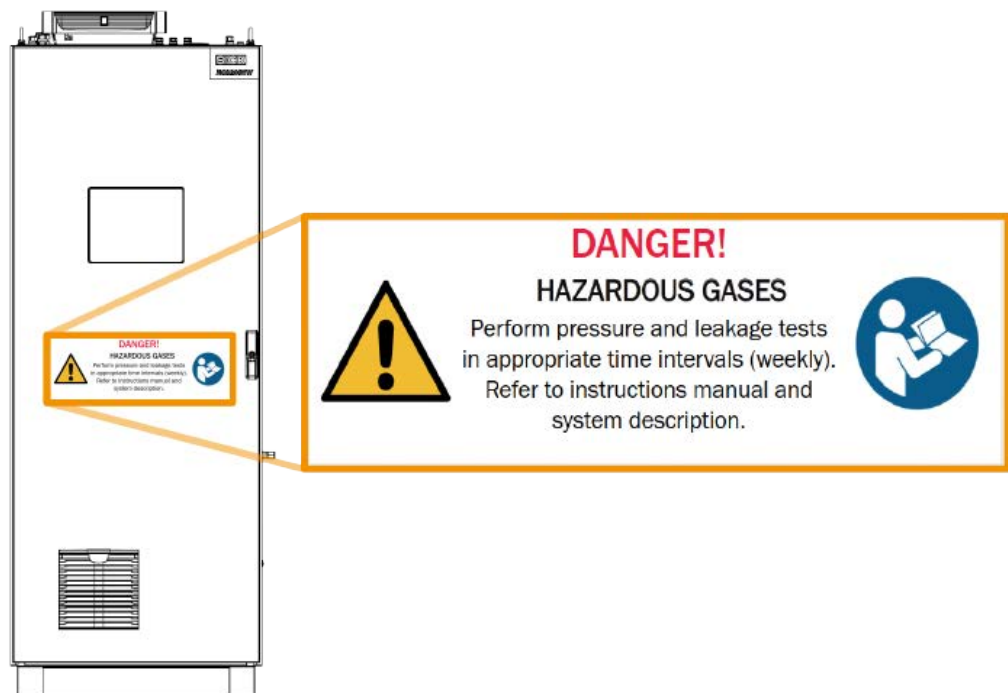

Fig. 1: Warning label on the analyzer cabinet door: DANGER - Hazardous Gases!

3 System description

NOTICE

The operating entity of the combination MCS200HW & GMS800 FIDOR must readjust the analyzers at the installation site before commissioning.



Additional information on adjustment/calibration can be found in:

- SICK operating instructions:
 - MCS200HW - multi-component analyzer systems.
 - GMS800 FIDOR - hydrocarbon analyzer (FID).

Sample gas sampling

Sample gas flows from a heated gas sampling probe to the MCS200HW analyzer via a heated sample gas line (extractive measurement).

Second sample gas line

The sample gas then flows from the MCS200HW analyzer to the FIDOR analyzer through a second heated sample gas line in the analyzer cabinet; the analyzer then determines the total amount of organic carbon (TOC - *total organic carbon*).

Measured values display

A display on the outside of the analyzer cabinet door shows calculated measured values. The system can also transmit measured values to other points, for example the control system.

Interfaces

Operators can use the system via Modbus, or using the inner and outside display on the analyzer cabinet.

Interface	Alternative designation	Controls	Main functions
Modbus	N/A	System	The system signal list displays all functions which are available for the operator via Modbus, for example: <ul style="list-style-type: none"> ● Display of all measured values. ● Display of all system notifications. ● Start adjustment.
Outside display	Web display	System	<ul style="list-style-type: none"> ● Display of all measured values. ● Display of all system notifications. ● Start adjustment for both analyzers, MCS200HW and FIDOR. ● Start adjustment only for MCS200HW. ● Operation of the MCS200HW.
Inside display	BCU display	FIDOR	<ul style="list-style-type: none"> ● Display of all measured values. ● Fixing a possible adjustment error in the FIDOR. ● Operation of the FIDOR.

Gaseous media

The following **gaseous media** can be necessary for operation:

Medium	Use as	Place of use	Source
Instrument air	<ul style="list-style-type: none"> Instrument air 	<ul style="list-style-type: none"> MCS200HW FIDOR 	<ul style="list-style-type: none"> Ambient air/Fac-tory instrument air Possible gas bottle for emergency air supply
Instrument air after preparation in analyzer cabinet	<ul style="list-style-type: none"> Zero gas 	<ul style="list-style-type: none"> Gas sampling probe MCS200HW FIDOR 	<ul style="list-style-type: none"> Air conditioning (<i>option</i>)
	<ul style="list-style-type: none"> Backwash air 	<ul style="list-style-type: none"> Gas sampling probe 	
	<ul style="list-style-type: none"> Control air 	<ul style="list-style-type: none"> Gas sampling probe 	
H ₂	<ul style="list-style-type: none"> Fuel gas 	<ul style="list-style-type: none"> FIDOR 	<ul style="list-style-type: none"> On-site
Test gases - depending on the application -	<ul style="list-style-type: none"> Test gas 	<ul style="list-style-type: none"> MCS200HW 	<ul style="list-style-type: none"> On-site
Test gases - depending on the application -	<ul style="list-style-type: none"> Test gas 	<ul style="list-style-type: none"> FIDOR 	<ul style="list-style-type: none"> On-site

Adjustment

NOTE

The operating entity of the combination MCS200 & GMS800 FIDOR must readjust the analyzers at the installation site before commissioning.

The analyzers can be adjusted using different interfaces:

Interface	Activated analyzer
Modbus	MCS200HW, FIDOR
Outside display (web display)	MCS200HW, FIDOR
Inside display (BCU display)	FIDOR (only required if the FIDOR show an adjustment error)

Automated adjustment is also possible using cyclically set triggers (timers).



Additional information on adjustment can be found in:

- SICK operating instructions:
 - MCS200HW - multi-component analyzer systems.
 - GMS800 FIDOR - hydrocarbon analyzer (FID)

There are two standard variants of the combination MCS200 & GMS800 FIDOR.

• **Stand Alone variant**

The analyzer system is installed in an analyzer cabinet. The installation site is a weather-protected room at the usage site.

• **Container variant**

The analyzer system is installed in a weather-protected container (analyzer shelter). One or several analyzer cabinets and the associated system components are installed in the container.

The two variants also differ due to the safety devices.

Stand Alone safety devices

Safety device	Stand Alone variant	
	Standard	Option
Fan monitoring	✓	
H ₂ concentration monitoring		✓
H ₂ volume flow limiter (choke)	✓	
H ₂ solenoid valve for stopping H ₂ feed in case of danger	✓	

Variant: Stand Alone analyzer cabinet

A Stand Alone analyzer cabinet is equipped with:

- An H₂ solenoid valve outside the cabinet which stops the H₂ feed in case of danger
- H₂ volume flow limiters (chokes) in the H₂ gas path

Also either with:

- An air flow monitoring system at the filter fan (air flow monitoring) in the analyzer cabinet
or
- An H₂ detector in the analyzer cabinet

If there is an H₂ monitoring system in the analyzer cabinet, monitoring of the filter fan by the air flow sensor is not necessary.

Container safety devices

Safety device	Container variant			
	In/On analyzer cabinet		In/On container ¹⁾	
	Standard	Option	Standard	Option
Fan monitoring		✓	✓ ²⁾	
H ₂ concentration monitoring		✓		✓ ³⁾
H ₂ volume flow limiter (choke)	N/A		✓	
H ₂ solenoid valve for stopping H ₂ feed in case of danger	N/A		✓	

1) If the safety devices are not present in the container (e.g. when retrofitting an MCS200HW&GMS800 FIDOR), the analyzer cabinet is treated as a Stand Alone variant.

2) If no fan monitoring system or no ventilation is installed in the container, e.g. due to the ambient conditions at the installation site (toxic atmospheres, climatic conditions), an H₂ concentration monitoring system is absolutely mandatory.

3) Also when using a fan with monitoring system in the container, we recommend installing an H₂ concentration monitoring system.

Containers are equipped with:

- An H₂ solenoid valve outside the container that stops the H₂ feed in case of danger
- An H₂ volume flow limiter (choke) outside the container

Also either with:

- Monitoring system of the container ventilation (standard)

and/or

- An H₂ monitoring system (optional).

If the above safety devices for the Container variant are installed in and on the container, the safety devices on the analyzer cabinets are left out.

Air monitoring system – option –

The system monitors the constant ventilation of the system. This prevents:

- The creation of an explosive H₂ atmosphere if there are leaks in the H₂ line.
- Collection of dangerous gases if there is a leak in the sample gas lines
- Overheating of system components

The system also stops the H₂ supply to the FIDOR if there is a fault in the ventilation.

The following installation sites are possible for the fan monitoring systems:

- In the fan filter in the analyzer cabinet (standard in Stand Alone variant).
- In the container ventilation (Container variant).

Filter fan

The filter fan in the analyzer cabinet door continuously sucks in ambient air, which then escapes through an opening in the cabinet ceiling. The air flow cools down the system component and prevents dangerous gas accumulations if there are leaks.

H₂ monitoring – option –

The FIDOR analyzer uses H₂ as fuel gas. An optional H₂ detector measures the H₂ concentration in the ambient air to identify leaks.

- At H₂ concentrations of 20% and 25% of the lower explosion level (LEL), visual and acoustic alarm signals go off.
- An H₂ shut-off valve stops the H₂ feed if:
 - The measured H₂ concentration in the ambient air is more than 25% LEL.
 - The ventilation fails or experiences a fault

3.1 Gas flow diagram



For more information see:

- Circuit diagram

3.2 Technical data

Technical parameters	
Normal network supply voltage	230 V / 50 Hz
Control voltage	24 VDC
Output	4,100 VA
Special features	<ul style="list-style-type: none"> • QAL3 - internal calibration • Modbus
Protection class	IP 54
Dimensions (H x W x D)	2,208 x 808 x 623 mm
Weight	200 kg per analyzer cabinet
Color	RAL 7035

3.3 Required instrument air quality

Depending on the type, different qualities of instrument air are required.



Additional information on instrument air can be found in the:

- Circuit diagram
- SICK operating instructions: MCS200HW multi-component analyzer system
- SICK operating instructions: GMS800 FIDOR hydrocarbon analyzer (FID)

3.4 Overviews

3.4.1 Overview 1 outside

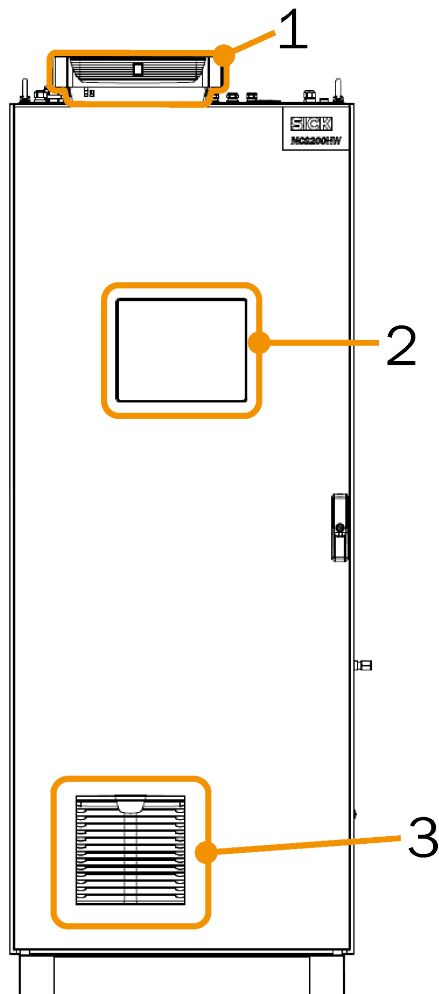

Legend

1	Air opening with filter for warm exhaust air
2	Outside display
3	Filter fan with louvered grills for ambient air intake

3.4.2 Overview 2 - inside - front view

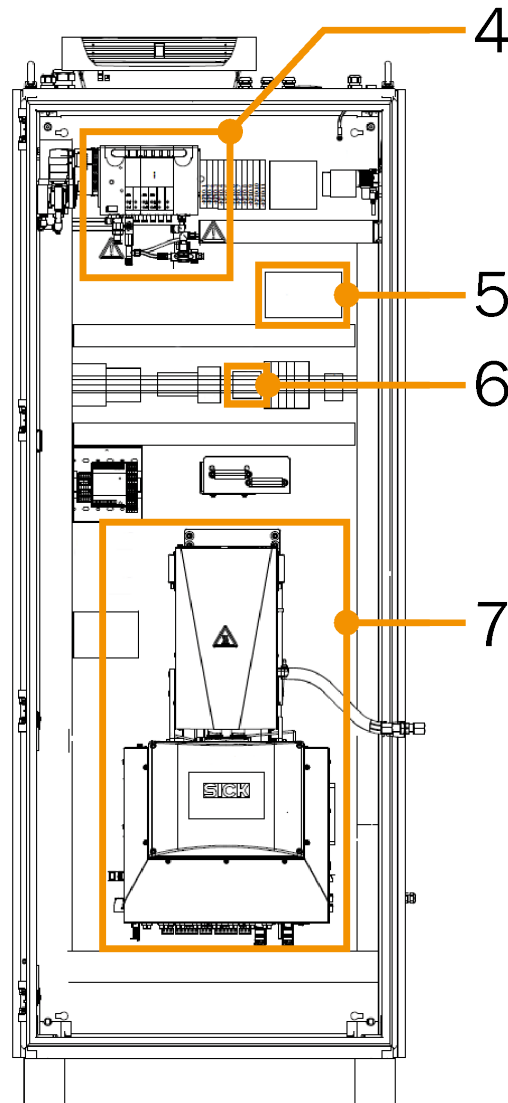

Legend

4	Valve block for instrument air distribution
5	Option - GMC 8022 evaluation unit (H ₂ -monitoring)
6	Option - air flow monitor
7	Analyzer MCS200HW

3.4.3 Overview 3 - inside - left side view

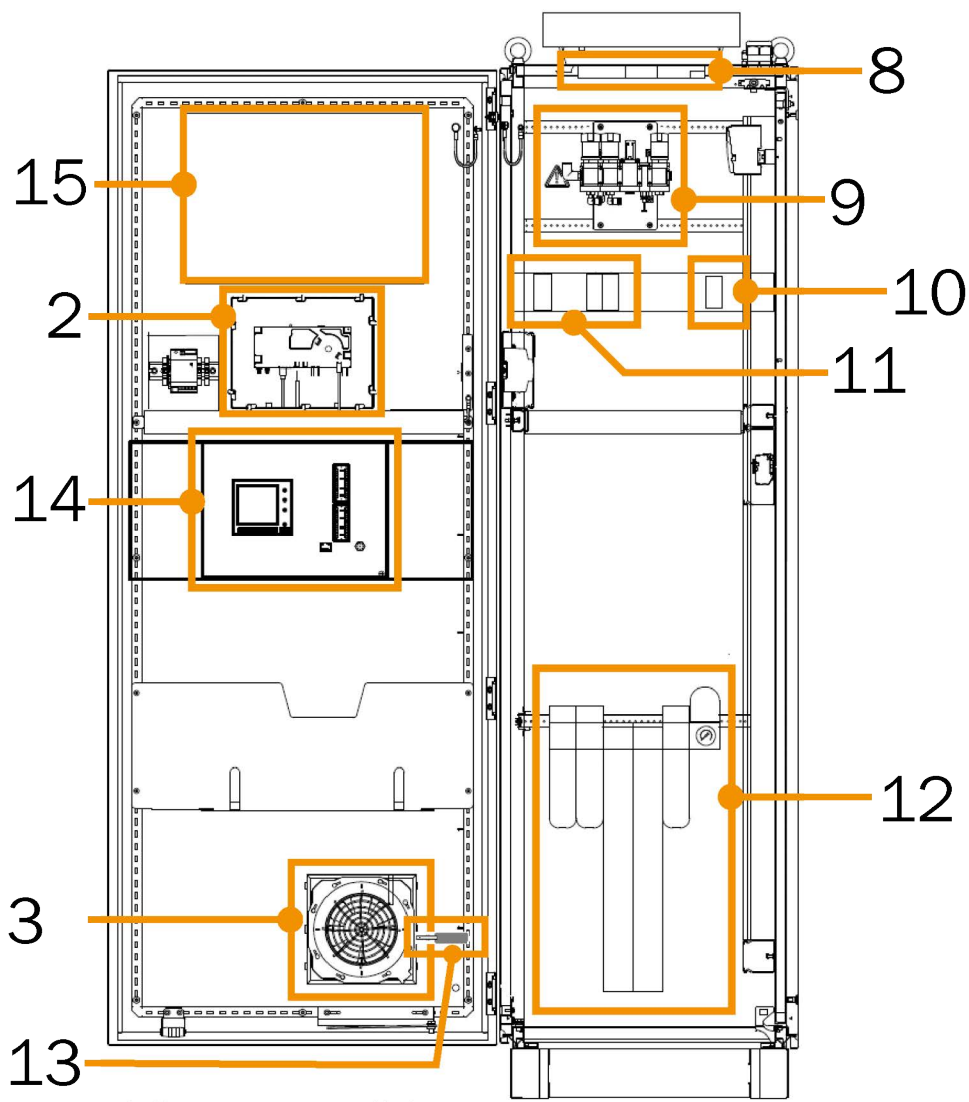

Legend	
2	Outdoor display for MCS200HW and complete system
3	Filter fan
8	LED control cabinet light
9	Pressure regulator module for instrument air
10	N/A - Pressure switch
11	N/A - Instrument air valves
12	Option - Instrument air preparation
13	Option - Airflow sensor
14	Basic Control Unit (BCU) with display for FIDOR
15	Analyzer FIDOR

3.4.4 Overview 4 - Inside right side view

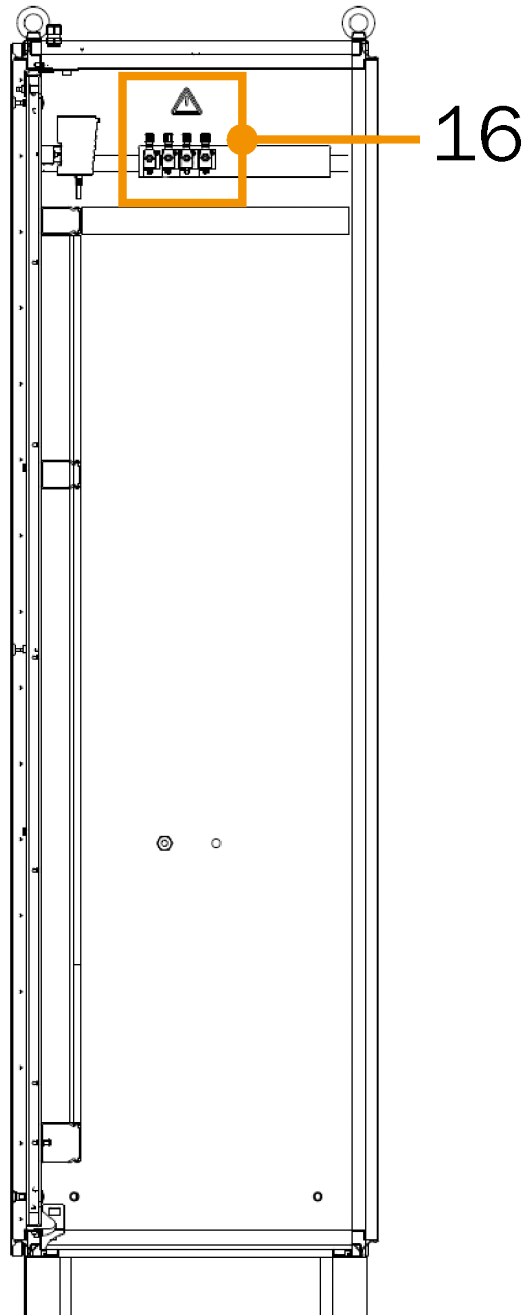

Legend

16	Test gas valves
----	-----------------

3.5 Heated sample gas line - type ELH



Abb. 4: Heated sample gas line, type ELH

Description

The sample gas flows through the measurement gas line from the gas sampling probe to the analyzer system cabinet and into the MCS200HW analyzer. Sample gas flows through another ELH sample gas line in the analyzer cabinet to the FIDOR analyzer, from the MCS200HW to the FIDOR.



The following documents contain more information:

- SICK operating instructions - heated sample gas line type ELH
- Circuit diagram

3.6 MCS200HW

System diagram



Abb. 5: System overview of an MCS200HW analyzer

Legend

1	SFU gas sampling probe (heated)
2	Heated sample gas line
3	Hose bundle line
4	Analyzer cabinet
5	Voltage supply
6	Interface connections
7	Instrument air input
8	Measurement distance
9	Condensate tank with sensor (option)

Measurement principles

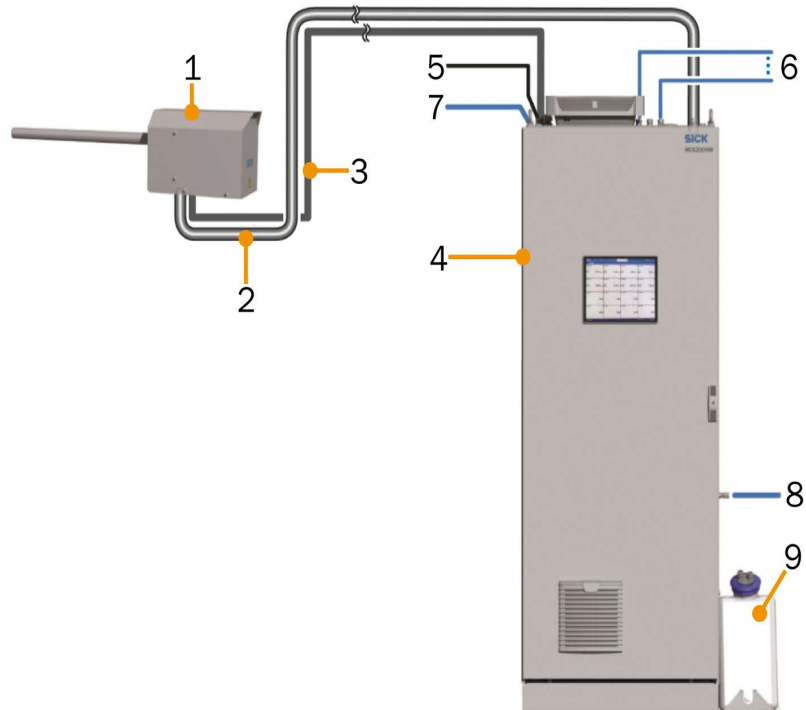
- Infrared single-beam photometer with interference filter and gas filter correlation process.
- Zirconium dioxide sensor

Measurement components

- Measured values are output in mg/Nm^3 or percent by volume (% by vol).

Information

The system works independently. The display in the analyzer cabinet door is used for operation. The operational statuses are shown using status signals and indicated on the display.

- Heating temperature of all parts touching the sample gas: Up to 200 °C.
- Instrument air drives an ejector pump in the measuring cell.
- Current operational statuses are shown on the display in the analyzer cabinet doors.
- If there is a fault, the analyzer system automatically switches to the “System Stop” operational status.

“System Stop”

With the “System Stop” operational status, the system automatically flushes the sample gas line and the sample gas path in the analyzer with instrument air. The measured values continue to be updated.

Testing (validation) and adjustment

- Zero point adjustment
- Reference point adjustment
- Adjustment with internal adjustment filter

Probe back flush

The gas sampling probe can be back flushed in the following ways:

- Automatically
 - ▶ Configuration with internal trigger, duration for 2 minutes every 4 minutes, for example.
- Manually
 - ▶ Manually using an interface.

Operation via display

The MCS200HW can be operated via the display on the door. Operation via PC (optional).

The operator menus and measurement value displays are available on an external PC (with the Google Chrome browser and SOPAS) via Ethernet.



The following documents contain more information:

- SICK operating instructions - MCS200HW multi-component analyzer system
- Circuit diagram

3.7 Outside display for the overall system



Abb. 10: Outside display

Legend	
1	Quick access
2	Search
3	Updating and editing
4	Display and selection fields
5	Date and time
6	Status indicators
7	Operational status
8	Current user
9	Menu path

Description

The analyzer system features a display with touchscreen.

- All menus and MCS200HW functions are shown on the display.
- The menus and functions are called up using control panels.
- The current operating status is shown with the status indicator.
- Displays collective messages of the FIDOR analyzer. Detailed messages of the FIDOR are shown in the inside display (BCU display in the inner door side).

FIDOR and BCU display

Hinweis

The operating interface for the FIDOR analyzer is the display (inside display) on the basic control unit (BCU) in the analyzer cabinet.



The following documents contain more information:

- SICK operating instructions - MCS200HW multi-component analyzer system.
- Addendum to operating instructions - BCU control unit
- SICK operating instructions: GMS800 FIDOR hydrocarbon analyzer (FID).

3.8 GMS800 FIDOR



Abb. 10: Position and illustration of the FIDOR analyzer on the inside of the cabinet door

Description

The FIDOR is a total hydrocarbon gas analyzer (FID) for continuous measurement of the total concentration of the organic carbon (TOC).

The sample gas is extracted at the measuring point and fed through the analyzer system (extractive measurement).

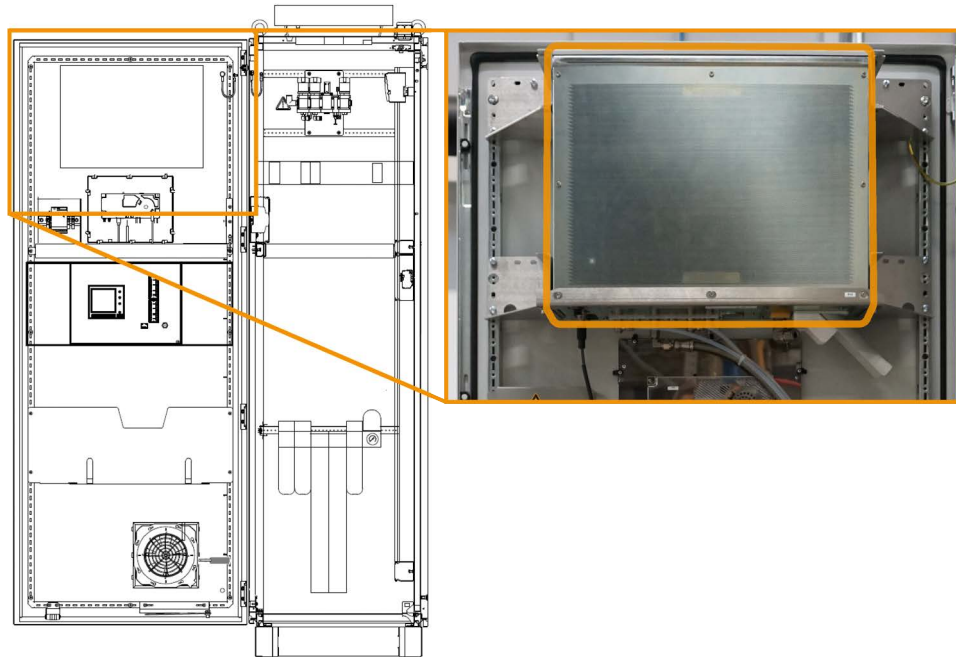
The devices are suitability-tested in accordance with DIN EN 15267 for continuous monitoring of emissions of organic carbon in line with:

- 13. BImSchV and TA Luft
- 17. BImSchV.

Measuring principle



Abb. 11: Measurement principle - flame ionization detection

Legend	
1	Combustion air (Instrument air)
2	Sample gas
3	Fuel gas

- FIDOR uses a flame ionization detector (FID) to measure hydrocarbons.
- A hydrogen flame, fed by fuel gas and combustion air, burns in an electrical field in the FID. The sample gas is guided to this flame.
- Hydrocarbons contained in the sample gas are split; the resulting CH fragments are ionized. An ion flow is generated in the electric field; this electrical current is measured.
- The measurement signal is proportional to the number of supplied non-oxidized carbon atoms. Carbons atoms which were already oxidized are only partially captured. CO and CO₂ are ineffective.
- The quantitative connection between the measurement signal and the carbon concentration in the sample gas is determined by running reference measurements with test gases which do not contain and hydrocarbons (zero gas) and/or whose exact hydrocarbon concentration is known (reference gas - for example 80 ppm propane in the air).
- Only a small amount of sample gas is burned for analysis. The majority is diluted with the instrument and combustion air and led outside via the exhaust air line.

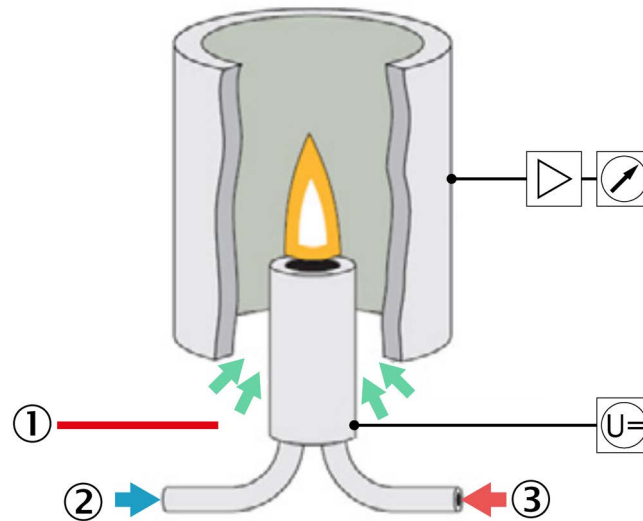

The following documents contain more information:

- SICK operating instructions: GMS800 FIDOR hydrocarbon analyzer (FID)
- SICK additional operating instructions - BCU control unit
- Circuit diagram

3.9 Inside display - Basic Control Unit



Abb. 2: Position and details of the BCU - basic control unit

Description

The BCU (basic control unit) control unit is the human machine interface to the FIDOR analyzer. Messages which affect the overall system and the FIDOR are shown on the outside display. The FIDOR is operated using the BCU display.

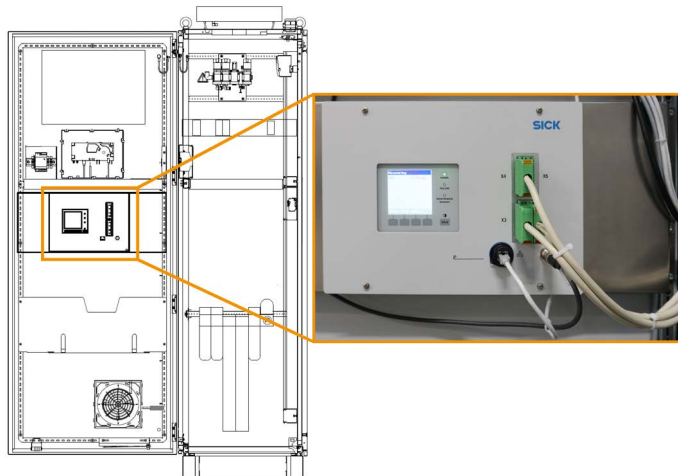

Abb. 4: Control elements and status indicators in the BCU display

Legend	
1	Current menu path
2	Currently active menu
3	Status bar
4	Menu number
5	LEDs (Power, Failure, Maintenance Request)
6	Contrast (To change: Press and hold MEAS pushbutton)
7	Press MEAS pushbutton for display of measured values
8	Function buttons (BACK, ENTER, MENU, etc.)

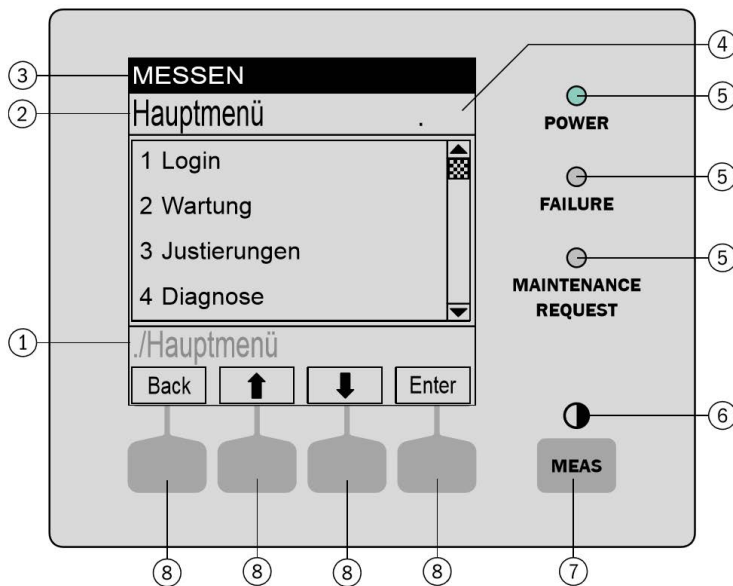

The following documents contain more information:

- SICK additional operating instructions - BCU control unit
- SICK operating instructions: GMS800 FIDOR hydrocarbon analyzer (FID)
- Circuit diagram

3.10 H₂ Shut-off Valve



Abb. 9: Illustration of an H₂ shut-off valve.

The H₂ shut-off valve is installed:

- On the analyzer cabinet - Stand Alone variant analyzer cabinet
- Outside the container - Container variant

The FIDOR analyzer uses H₂ as fuel gas. To prevent an explosive H₂ atmosphere from forming, the system can stop the H₂ supply to the FIDOR with a shut-off valve (H₂ shut-off valve).

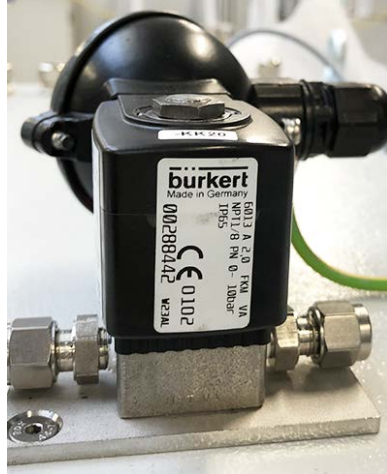
The H₂ shut-off valve stops the supply when:

- The air monitoring system signals a fault or fan failure.
- The H₂ monitoring system detects an H₂ concentration of 25% LEL and above.

Description Fan failure

Prerequisite: System has a fan monitoring system.

If a fan fails or a fan experiences a fault, an H₂ shut-off valve stops the H₂ supply. Not until the fault is fixed and it is safe can the H₂ supply be released.

Description H₂ = 25% LEL alarm

Prerequisite: System has an H₂ monitoring system with H₂ detector.

At an LEL alarm of 25%, an H₂ shut-off valve stops the H₂ supply. When it is safe and the H₂ concentration is low enough, pressing the reset pushbutton on the GMC 8022 controller re-opens the H₂ supply.



The following documents contain more information:

- Circuit diagram

3.11 Filter fan

The filter fan in the analyzer cabinet is used to:

- Force dangerous collections of gas out of the cabinet in case of leaks
- Cool the system components

Variant: Stand Alone analyzer cabinet

In a Stand Alone analyzer cabinet, an air flow sensor on the filter fan monitors the air flow by default.

If there is an H₂ monitoring system in the analyzer cabinet, monitoring of the filter fan by the air flow sensor is not necessary.

Variant: Analyzer cabinet in a container

Filter fans in the analyzer cabinets which are installed in a container do not have a monitoring system with an air flow sensor by default.

Containers are equipped with:

- An H₂ solenoid valve outside the container that stops the H₂ feed in case of danger
- An H₂ volume flow limiter (choke) outside the container
- At least with one of the following safety devices:
 - Monitoring system of the container ventilation
 - H₂ monitoring system in the container



Abb. 10: Filter fan with air flow sensor

Legend	
1	Filter fan
2	Air flow sensor (Stand Alone variant)

The fan sucks air into the cabinet through the louvered grills. An exchangeable filter mat is used between the grills and fan which must be checked for contamination on a regular basis. The air sucked in flows back into the environment through a ventilation opening in the analyzer cabinet.

**WARNING****Hazards posed by dangerous gases collecting in the analyzer cabinets**

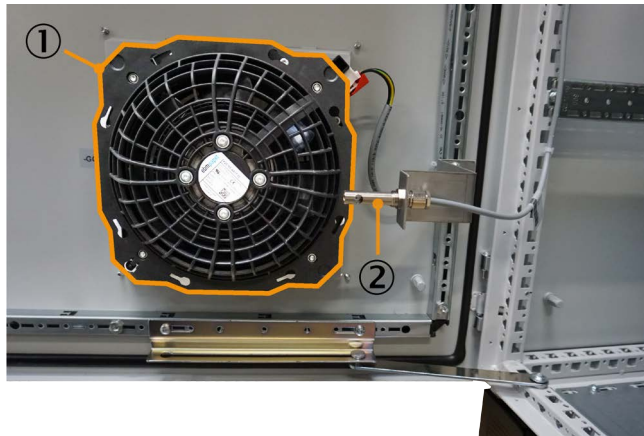
- Gases can collect in the cabinet if there are leaks and the fan fails.
- ▶ Check that the following are working correctly on a regular basis:
 - ▶ Fan
 - ▶ Air flow monitoring system (option - fan monitoring system)
 - ▶ Error signals of the air monitoring system (option)
- ▶ Do not cover or plug ventilation openings.
- ▶ Clean fan and ventilation openings on a regular basis.

Notice - Cleaning

Check the filter fan and its main components (fan, filter and louvered grills) for contamination and clean.

Hinweis - Ventilation opening in the analyzer cabinet ceiling

Do not cover or plug ventilation openings.



The following documents contain more information:

- Mounting, installation and operating instructions of the filter fan
- Circuit diagram

3.12 Instrument air conditioning (option)

Description

- Preparation of the instrument air



Abb. 3: Illustration of compressed air conditioning, type VarioDry FRL SF 0025 membrane dryer.

Legend	
1	Pre-filtration/Separator level
2	Sub-micro filter
3	Membrane module
4	Activated carbon filter
5	Pressure regulator

Function

2-stage pre-filtration (①.②) – filtration (③. ④) – pressure regulator (⑤)

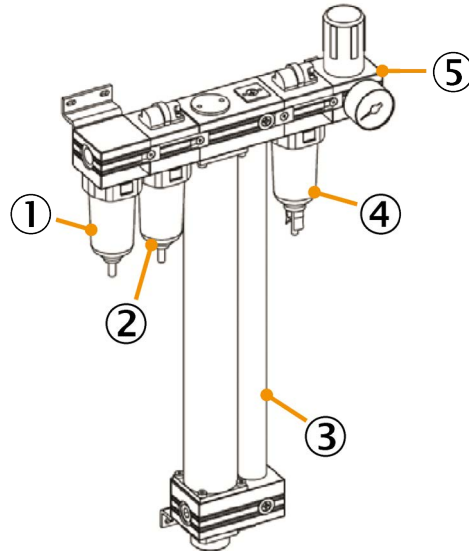
In the first stage (①) of pre-filtration, particles and drops of water are held back. This protects the following sub-micro filter (②) in the second stage of pre-filtration.

The sub-micro filter (②) (coalescence filter) removes oils aerosols up to a size of 0.01 mg/m³. After this stage, the compressed air quality relating to the solid particles complies with class 1 according to ISO 8573-1.

The 2-stage pre-filtration process protects the following membrane module (③) from liquids and solids. Depending on the conditions for participation, the compressed air can be dried to a pressure dew point of -40 °C.

The following active carbon filter (④) removes water vapor, hydrocarbons and substances containing flavors and odors. The achieved compressed air quality relating to oil complies with class 1 according to ISO 8573-1. The operating pressure can be set specifically for terminal application with the pressure regulator (⑤).



The following documents contain more information:

- Circuit diagram
- Data sheet - VarioDry FRL SF 0010 - SF 0150 membrane dryer

3.13 H₂ monitoring (option)

Prerequisite: H₂ monitoring system is installed.

Since the FIDOR analyzer uses H₂ as fuel gas, an H₂ detector monitors the ambient air for high H₂ concentration. The GMC 8022 controller connected to the detector calculates the H₂ concentration and shows the results as a percentage of the lower explosion limit (LEL) on the corresponding display. Depending on the type, the system can forward the measured value and the alarm to a control center, for example.

Variant: Stand Alone analyzer cabinet

- An H₂ detector in the analyzer cabinet.
- A controller in the analyzer cabinet.
- An H₂ solenoid valve on the analyzer cabinet which stops the H₂ feed in case of danger.
- An H₂ volume flow limiter (choke) in the H₂ line.
- An alarm horn with integrated flashing light in the analyzer cabinet.

Variant: Analyzer cabinet in a container

If the H₂ concentration in the room air is monitored in a container, then the container is equipped with:

- An H₂ detector in the container
- A controller in the container, for example in a signal cabinet.
- An H₂ solenoid valve outside the container that stops the H₂ feed in case of danger
- An H₂ volume flow limiter (choke) outside the container
- An alarm horn with integrated flashing light in and/or outside the container



Abb. 6: Diagram of the H₂ monitoring system with detector, controller and alarms.

The H₂ monitoring system has four main components:

No	Component	Task
1	H ₂ detector	Currently measures H ₂ concentration in the ambient air
2	Controller	Evaluation, display, signaling, initiating protective measures
3	Alarm horn	Acoustic alarm (from H ₂ ≥ 20% LEL) and flashing light (from H ₂ ≥ 25% LEL).
4	H ₂ shut-off valve	Stops H ₂ supply at H ₂ =25% LEL.

Alarm

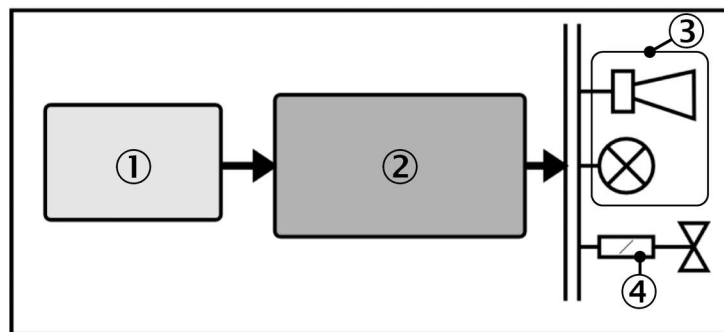
- From an H₂ concentration of 20% LEL, the alarm horn goes off.
- From an H₂ concentration of 25% LEL
 - Also flashes the flashing light of the alarm horns
 - The H₂ shut-off valve stops the H₂ supply to the FIDOR analyzer.
 - when the LEL drops to < 25%, the signal tone is automatically switched off. The flashing light and valve must be switched off by pressing the reset key on the evaluation unit GMC 8022, must be switched off.

Confirming H₂ alarm

A 25% LEL alarm is a self-locking alarm.



WARNING

Risk of explosion with H₂ alarm

Death or serious injury due to explosion

- Explosive atmospheres can occur at the installation site if there are leaks:
 - ▶ Put on personal protective equipment.
 - ▶ Use a portable gas warning device
 - ▶ Put on suitable eye protection when H₂ concentration is very high
 - ▶ Put on eye protection when there is danger of deflagration
 - ▶ Wear protective clothing if necessary
- ▶ Do not open detector if explosive atmospheres could be present.
- ▶ Only confirm the H₂ alarm manually when the danger has past.

An operator must press the reset pushbutton on the GMC 8022 controller to switch off the horns and flashing light.

The GMC 8022 controller is installed:

- In the analyzer cabinet (Stand Alone variant) or
- In a control cabinet in the analyzer shelter (Container variant)



The following documents contain more information:

- Circuit diagram
- Data sheet - gas measurement and warning systems – HC150 ExDetector
- Data sheet - gas measurement and warning systems – GMC 8022.

3.13.1 H₂ detector (H₂ monitoring option)



WARNUNG

Explosion risk

Severe injury or death if explosive atmospheres are present

- ▶ Do not open H₂ detector if explosive atmospheres could be present.



Abb. 7: Illustration of an H₂ detector, type HC150, with test label.

Description

The H₂ detector measures the H₂ concentration in the ambient air as a percentage of the lower explosion level (LEL) of H₂.

The associated GMC8022 controller calculates the measured values, shows the currently measured value on the display and initiates an alarm when the alarm thresholds are reached.

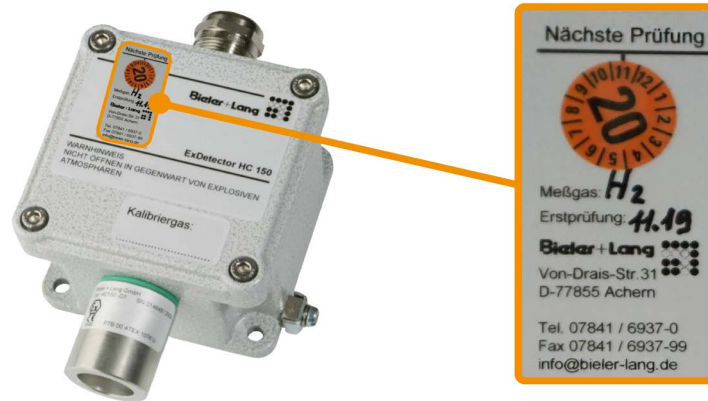
The unit also gives the signal to close the H₂ shut-off valve (only at 25% LEL alarm).

Alarm threshold	Unit	System response
20	% of LEL for H ₂	▶ Horn tone
25	% of LEL for H ₂	▶ Additional flashing light ▶ H ₂ shut-off valve stops H ₂ supply to the FIDOR.

Hinweis

The operating entity of the system must check if the H₂ detector is functioning correctly on a regular basis. To do so, the intervals specified by the manufacturer of the H₂ detector must be observed. A test label on the detector specifies the date by which the device must be tested.

3.13.2 H₂ monitoring system controller- GMC 8022



Abb. 8: Illustration of an H₂ controller, type GMC 8022, with reset button (1)

Legend

1	Reset pushbutton for confirming H ₂ alarms, switching off flashing light and reopening H ₂ shut-off valve.
---	--

Description

The GMC 8022 controller is part of the H₂ monitoring system. It shows the operational status of the monitoring systems, calculates the H₂ concentration in the ambient air from measured values of the H₂ detector and initiates alarms and the associated protective measures, for example the alarm horns.

The H₂ monitoring system contains the H₂ detector, the GMC 8022 controller, an alarm horn and a shut-off valve which stops the H₂ supply if an alarm goes off.

Confirming alarm manually



WARNING

Risk of explosion with H₂ alarm

Death or serious injury due to explosion

- Only confirm the alarm manually when the danger has passed.
- Explosive gas mixtures can occur at the installation site if there are leaks:
 - ▶ Wear personal protective equipment.
 - ▶ Use a portable gas warning device
 - ▶ Put on suitable eye protection when H₂ concentration is very high
 - ▶ Put on eye protection when there is danger of deflagration
 - ▶ Wear protective clothing if necessary

After a 25% LEL alarm, the alarm and the horns are switched off when an operator presses the reset pushbutton by hand.

3.13.3 Alarm horns (H₂ monitoring option)



Abb. 2: Illustration of alarm horns with integrated flashing light

Description

The alarm horn goes off at a measured H₂ concentration of 20% LEL.

If the H₂ concentration rises to 25% LEL and above, the integrated flashing light also goes off, and the horns continue to as well. The H₂ shut-off valve also stops the H₂ supply.

Alarm threshold	Unit	System response
20	% of LEL for H ₂	▶ Horn tone
25	% of LEL for H ₂	▶ Additional flashing light ▶ Stop of H ₂ supply

3.13.4 More information on the H₂ monitoring system



The following documents contain more information:

- Circuit diagram
- Data sheet - gas measurement and warning systems – GMC 8022.
- Data sheet - gas measurement and warning systems – HC150 ExDetector

For fan monitoring:

- Operating instructions of the associated components

3.14 Fan monitoring (standard - Stand Alone variant).



Abb. 3: Components of the fan monitoring system in the analyzer cabinet

Legend	
1	Air flow monitor
2	H ₂ shut-off valve
3	Filter fan
4	Air flow sensor

Description

An air flow sensor 1 monitors the air flow at the filter fan 2. If the air flow is too low or breaks off, the associated air flow monitor 3 signals a maintenance request. At the same time, a shut-off valve 4 on the analyzer cabinet roof shuts off the H₂-supply to the FIDOR analyzer.

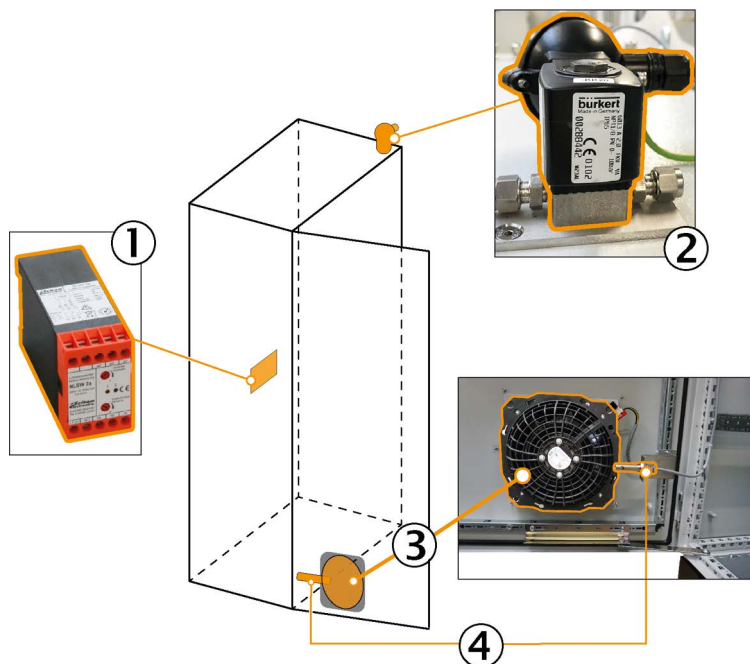
NOTICE : Check the function of the air monitoring system on a regular basis!



More information on checking and setting the air monitoring system:

- Operating instructions for the NLSW2a / NLSW2aZ air flow monitor
- Operating instructions for the F2, F3, F4.2, F4.3 flow sensors

3.14.1 Air flow monitor



Abb. 5: Air flow monitor and its position in the analyzer cabinet

Description

Together with the air flow sensor, the air flow monitor monitors whether the filter fan pushes enough air into the analyzer cabinet. If the air flow is too low, the system signals a fan failure and blocks the H₂ supply to the FIDOR analyzer; the measurement stops.

Measurement principle

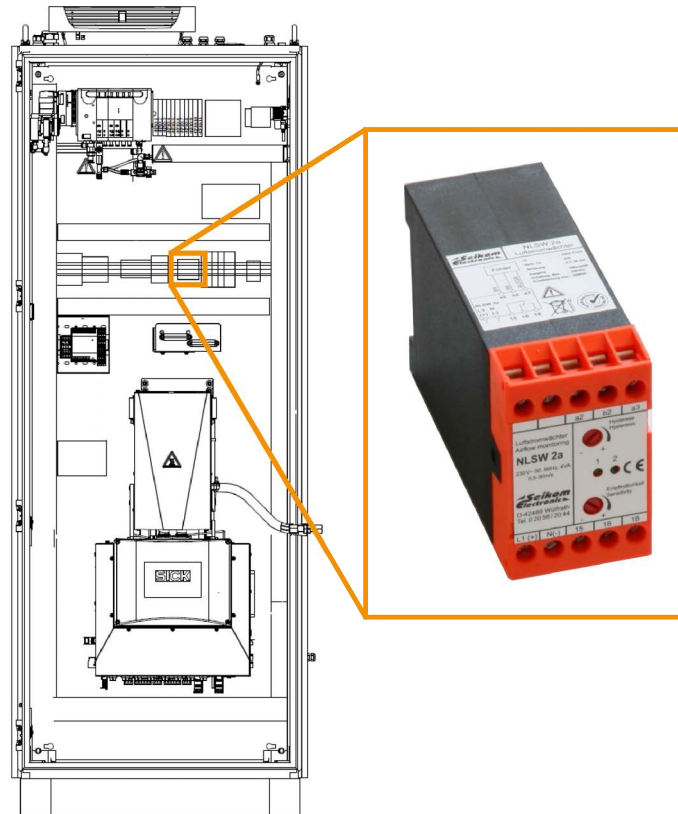
The air flow monitor functions in line with the calorimetric principle. The device switches when a set threshold is reached.

Breakage in the air flow sensor line or a defect in the air flow sensor is detected by the guard and reported by the output relay dropping. A yellow LED on the guard signals the current switching state:

Air flow \geq threshold value	LED lights up yellow
Air flow $<$ threshold value	LED off



The following documents contain more information:

- Operating instructions for the NLSW2a / NLSW2aZ air flow monitor
- Operating instructions for the F2, F3, F4.2, F4.3 flow sensors

3.14.2 Air flow sensor



Abb. 3: Highlighted on the right of the view is the air flow sensor, type F2 before the filter fan

Description

The air flow sensor, a unit with the air flow monitor, monitors the air flow in the control cabinet.

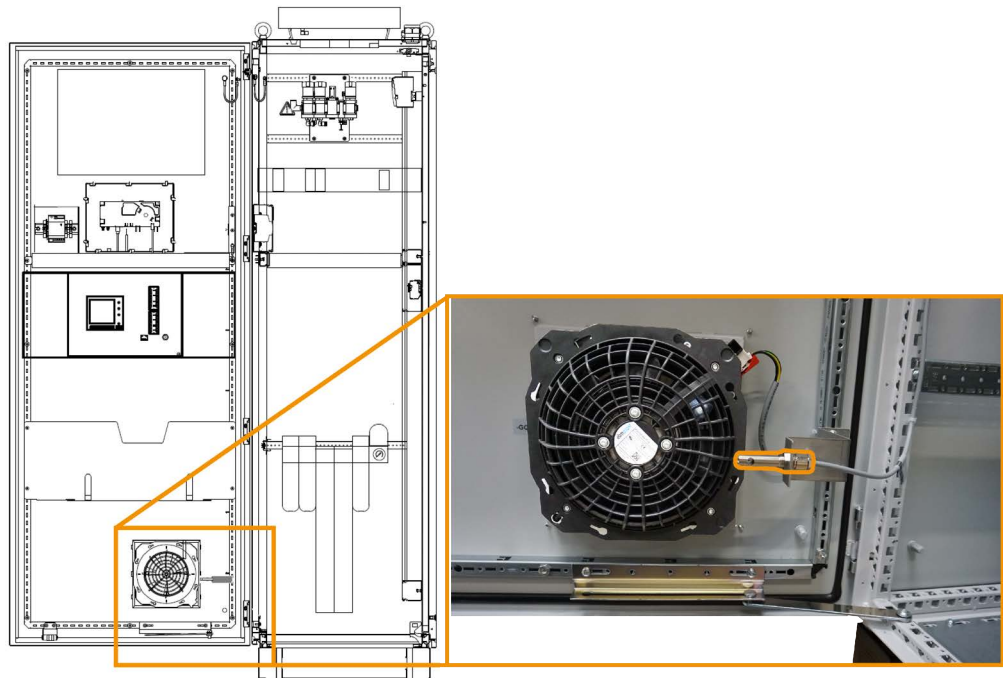

The following documents contain more information:

- Circuit diagram
- Operating instructions for the NLSW2a / NLSW2aZ air flow monitor.
- Operating instructions for the F2, F3, F4.2, F4.3 flow sensors.

3.15 Air monitoring system (container option)

Description

Ventilation in the shelter is monitored by specific devices. If there is a fault, for example if a filter is clogged, the system stops the H₂ supply to the analyzer using the H₂ shut-off valve. The system releases the H₂ supply when the fault is eliminated.



The following documents contain more information:

- Circuit diagram.

4 Maintenance

Note

Only qualified personnel from the respective field are allowed to work on the system.



DANGER

Explosion hazard due to hydrogen H₂

Serious injury or death.

- ▶ Regularly check pipes and pipe connections for strength and tightness. Use leak detection spray and leak tester.
- ▶ Observe all local laws, technical rules and operator instructions.
- ▶ Do not smoke or carry any other possible sources of ignition inside or outside the analyzer room.

4.1 HC 150 - H₂ Gas Sensor

The gas sensor must be serviced and checked regularly to ensure operational safety. The checks are divided into visual, operational and system checks.

Minimum required activities:

Visual controls

- ▶ Gas detection components for mechanical damage.
- ▶ Status of the evaluation unit.
- ▶ Gas inlet openings for contamination, e.g. dust and dirt.

Operational controls

- ▶ Visual check.
- ▶ Pressurize the gas detector with zero and test gas to check the measured value display and adjust if necessary. In addition, the response behavior must be checked and evaluated (see manufacturer's annexes).
- ▶ During operation, trigger the test function on the status indicator without triggering the switching functions.

By carrying out a company audit, the visual inspection is not required, as this is included in the operational audit.

System control

- ▶ Includes a function control.
- ▶ The safety functions and the triggering of the switching functions must be tested (e.g. warning devices, shutdown functions - fail-safe operation).
- ▶ Test the configuration with an match code comparison.
- ▶ Test the alarm devices and the recording devices.

By carrying out a system test, the function test is not required, as this is included in the system test.

Setting the test intervals

The intervals specified here are maximum values and should not be exceeded. After commissioning the plant, shorter intervals must initially be selected.

In the first four weeks, an operational check should be carried out every week. If no adjustments are made, the next three operational checks should take place at intervals of four weeks. If no adjustments are made during this time, the below If no adjustments are made during this time, the maximum interval (4 months) indicated below can be applied.

Exceptions: If adjustments are made within the first 16 weeks, the maximum interval (4 months) it is not permissible to apply the maximum interval. In such cases, an individual interval must be interval for the system must be determined iteratively.

The maximum intervals between controls should be as follows:

Test type	Intervals
Visual inspection by instructed person	1 month
Functional check by qualified personnel	4 months
System check by qualified personnel	1 year
Periodic inspection by qualified persons	3 years

5 Spare parts list

Component / Assembly

Component 1		H2 Monitoring				
BMK		BQ3				
Material number	Designation	WP	SP	necessary quantity		
				yearly	every 3 years	every 5 years
1. 6026462	Sensor replacement ExDetektor HC150 (H2)	-	X	-	1	-

Component 2		MCS200HW				
BMK		BQ1				
Material number	Designation	WP	SP	necessary quantity		
				yearly	every 3 years	every 5 years
1. 2105314	Maintenance kit (Gas sample filter) Consists of: 1x fine filter cartridge, 2µm; silicone, stainless steel 1.4401, / 1 x O-ring, 80mm x 3mm, Viton; 1 x flat seal; 1 x flat sealing ring.	X	-	1	2	5
2. 5310158	Valves (Gas sample filter) Check valve, 25psi; NPT-Außengewinde 1/4"; NPT male thread, stainless steel, Viton.	X	-	2	4	10
3. 2099790	Emitter (Analyzer) Emitter, complete, including desiccant sachet.	X	-	-	-	1
4. 2100150	Maintenance kit (Analyzer) for yearly maintenance Consists of: maintenance kit "cell input window"; set for filter mat, for cabinet door fan and roof vent; filter mat, 118mm x 118mm, chemical fiber.	X	-	1	2	5
5. 2099680	Maintenance kit (Analyzer) gas conveyance block Consists of: O-rings; sealing ring; screws; spring washers; tool for pulling out the nozzle of the ejector.	X	-	-	1	2
6. 2045740	Maintenance kit (Analyzer) cell window Consists of: 2 x cuvette window, barium fluoride; 8 x O-ring; 2 x V-Ring.	X	-	-	1	2

Component 3		FIDOR				
BMK		BQ2				
Material number	Designation	WP	SP	necessary quantity		
				yearly	every 3 years	every 5 years
1. 2052248	Seals (FID-Detector) O-rinf set für FID-Detector 200 °C Consists of: 2 x O-ring, 2.5 mm x 1.0 mm, Perlast; 4 x O-ring, 8.0mm x 1.5mm, Perlast.	X	-	-	1	2
2. 2055531	Maintenance kit (FID-Detector) glow plug Consists of: 1 x glow plug 1.5 V ; 1 x connecting cable for glow plug; 1 x flat sealing ring.	X	-	-	1	2
3. 2061176	Cables (FID-Detector) signal cables 1 pair of coaxial cables, preassembled, for tension and detector signal.	-	X	-	-	1
4. 2061270	Seals O-ring set for ejector Consists of: 1 x O-ring, 4.8mm x 2mm, Perlast; 1 x O-ring, 12.0mm x 2mm, Perlast.	X	-	-	-	1
5. 2061271	Seals O-ring for bypass throttle orifice O-ring, 6mm x 1.5mm, Perlast, for bypass gas orifice.	X	-	-	-	1
6. 2061269	Nozzles and capillares / measurement gas orifice M4 x 5, interior Ø 0.5mm, stainless steel.	-	X	-	-	1
7. 2061156	Mechanical filters (Measuemnt gas inlet) Filter element kit Consists of: 1 x sintered metal filter element, 20mm x 3mm, stainless steel 1.4404; 1 x O-ring, 15.5 mm x 2.5 mm, FFKM/Perlast.	X	-	1	2	5



For more information:

- Circuit diagram.
- Technical documentation for system components.

In case of doubt, contact SICK Service.

6 Disposal

Note

Note the relevant currently valid local and legal environment regulations and directives for the disposal of industrial and electronic waste.

Disposal of batteries, electrical and electronic equipment

According to international directives and regulations, batteries, accumulators and electrical or electronic devices must not be disposed of as household waste.

The owner is obliged to dispose of the equipment at the end of its service life at the appropriate public collection points.

This symbol on the product, packaging or in this document indicates that a product is subject to these regulations.



The following assemblies may contain substances that must be disposed of separately:

Electronics: capacitors, accumulators, batteries

Displays: Liquid in the LC-Displays

Sample gas lines:

Toxic substances of the sample gas can penetrate or adhere to soft materials of the gas path (e.g. hoses, sealing rings). Such effects must be taken into account during disposal.

Gas analyzer:



For detailed information to the disposal of analyzer modules, refer to the respective Operating Instructions.

Australia

Phone +61 (3) 9457 0600
1800 33 48 02 – tollfree
E-Mail sales@sick.com.au

Austria

Phone +43 (0) 2236 62288-0
E-Mail office@sick.at

Belgium/Luxembourg

Phone +32 (0) 2 466 55 66
E-Mail info@sick.be

Brazil

Phone +55 11 3215-4900
E-Mail comercial@sick.com.br

Canada

Phone +1 905.771.1444
E-Mail cs.canada@sick.com

Czech Republic

Phone +420 234 719 500
E-Mail sick@sick.cz

Chile

Phone +56 (2) 2274 7430
E-Mail chile@sick.com

China

Phone +86 20 2882 3600
E-Mail info.china@sick.net.cn

Denmark

Phone +45 45 82 64 00
E-Mail sick@sick.dk

Finland

Phone +358-9-25 15 800
E-Mail sick@sick.fi

France

Phone +33 1 64 62 35 00
E-Mail info@sick.fr

Germany

Phone +49 (0) 2 11 53 010
E-Mail info@sick.de

Greece

Phone +30 210 6825100
E-Mail office@sick.com.gr

Hong Kong

Phone +852 2153 6300
E-Mail ghk@sick.com.hk

Hungary

Phone +36 1 371 2680
E-Mail ertekesites@sick.hu

India

Phone +91-22-6119 8900
E-Mail info@sick-india.com

Israel

Phone +972 97110 11
E-Mail info@sick-sensors.com

Italy

Phone +39 02 27 43 41
E-Mail info@sick.it

Japan

Phone +81 3 5309 2112
E-Mail support@sick.jp

Malaysia

Phone +603-8080 7425
E-Mail enquiry.my@sick.com

Mexico

Phone +52 (472) 748 9451
E-Mail mexico@sick.com

Netherlands

Phone +31 (0) 30 229 25 44
E-Mail info@sick.nl

New Zealand

Phone +64 9 415 0459
0800 222 278 – tollfree
E-Mail sales@sick.co.nz

Norway

Phone +47 67 81 50 00
E-Mail sick@sick.no

Poland

Phone +48 22 539 41 00
E-Mail info@sick.pl

Romania

Phone +40 356-17 11 20
E-Mail office@sick.ro

Russia

Phone +7 495 283 09 90
E-Mail info@sick.ru

Singapore

Phone +65 6744 3732
E-Mail sales.gsg@sick.com

Slovakia

Phone +421 482 901 201
E-Mail mail@sick-sk.sk

Slovenia

Phone +386 591 78849
E-Mail office@sick.si

South Africa

Phone +27 10 060 0550
E-Mail info@sickautomation.co.za

South Korea

Phone +82 2 786 6321/4
E-Mail infokorea@sick.com

Spain

Phone +34 93 480 31 00
E-Mail info@sick.es

Sweden

Phone +46 10 110 10 00
E-Mail info@sick.se

Switzerland

Phone +41 41 619 29 39
E-Mail contact@sick.ch

Taiwan

Phone +886-2-2375-6288
E-Mail sales@sick.com.tw

Thailand

Phone +66 2 645 0009
E-Mail marcom.th@sick.com

Turkey

Phone +90 (216) 528 50 00
E-Mail info@sick.com.tr

United Arab Emirates

Phone +971 (0) 4 88 65 878
E-Mail contact@sick.ae

United Kingdom

Phone +44 (0)17278 31121
E-Mail info@sick.co.uk

USA

Phone +1 800.325.7425
E-Mail info@sick.com

Vietnam

Phone +65 6744 3732
E-Mail sales.gsg@sick.com

Detailed addresses and further locations at www.sick.com