

MARSIC200

Ship Emission Measuring Device

Operation, Maintenance, Troubleshooting

SICK
Sensor Intelligence.



Described product

MARSIC200

Manufacturer

SICK AG
Erwin-Sick-Str. 1
79183 Waldkirch
Germany

Legal information

This work is protected by copyright. Any rights derived from the copyright shall be reserved for SICK AG. Reproduction of this document or parts of this document is only permissible within the limits of the legal determination of Copyright Law. Any modification, abridgment or translation of this document is prohibited without the express written permission of SICK AG.

The trademarks stated in this document are the property of their respective owner.

© SICK AG. All rights reserved.

Original document

This document is an original document of SICK AG.



Contents

1	About this document.....	7
1.1	Function of this document.....	7
1.2	Target group.....	7
1.3	Further information.....	7
1.4	Symbols and document conventions.....	8
1.4.1	Warning symbols.....	8
1.4.2	Warning levels / Signal words.....	8
1.4.3	Information symbols.....	8
1.5	Intended use.....	9
1.5.1	Installation location.....	9
2	Product description.....	10
2.1	Product identification.....	10
2.2	Gas supply terminology.....	10
2.3	Layout and function.....	11
2.3.1	Sampling probe.....	14
2.3.2	Sample gas line, heated.....	15
2.3.3	Sample conditioning.....	15
2.3.4	Distribution unit.....	17
2.3.5	Analyzer.....	18
2.4	Remote maintenance (optional).....	19
3	Commissioning.....	21
3.1	Before switching on.....	21
3.2	Switching on.....	21
3.3	Recognizing the safe operating state.....	22
4	Operation.....	23
4.1	Operating and display elements.....	23
4.1.1	LEDs.....	23
4.1.2	Function buttons.....	23
4.2	Measuring screen.....	24
4.3	Display lighting.....	24
4.4	Internal clock buffer time.....	25
5	Adjustment with zero and span gas.....	26
5.1	Zero point adjustment.....	26
5.2	Reference point adjustment.....	26
5.3	Performing the adjustment.....	27
5.3.1	Connect zero or span gas.....	27
5.3.2	Configuration in menu.....	29
5.3.3	Start the adjustment.....	29
5.3.3.1	Adjusting one component.....	30
5.3.3.2	Adjusting several components.....	30

6	Menus.....	32
6.1	Menu tree.....	32
6.2	Main menu.....	32
6.3	User level (Login).....	33
6.4	Maintenance functions.....	33
6.4.1	Maintenance mode	33
6.4.2	Reset.....	34
6.5	Adjustment functions.....	35
6.5.1	Adjustment of single components	35
6.5.1.1	Prerequisites for manual adjustments.....	35
6.5.1.2	Starting the adjustment procedure.....	36
6.5.1.3	Carrying out the adjustment procedure.....	36
6.5.1.4	Viewing adjustment results.....	40
6.5.2	Validation of single components.....	41
6.5.2.1	Viewing validation results.....	43
6.5.3	Adjustment/validation of several components (group function).....	44
6.5.3.1	Starting adjustment manually (Group function)...	44
6.5.4	Setting an automatic adjustment start.....	44
6.5.4.1	Activating/deactivating adjustment.....	45
6.5.4.2	Setting the interval for the automatic adjustment.....	45
6.5.4.3	Setting the start time for the next adjustment....	46
6.5.5	General settings for adjustments.....	46
6.5.5.1	Setting the measuring time for adjustments.....	46
6.5.5.2	Setting the sample gas flush time for adjustments.....	47
6.5.6	Configuring test gases.....	48
6.5.6.1	Principle for test gas settings.....	48
6.5.6.2	Menu Test gase.....	49
6.5.6.3	Programming a test gas setting - Part 1: Integration.....	50
6.5.6.4	Programming a test gas setting - Part 2: Usage...	51
6.6	Diagnosis functions.....	54
6.6.1	Diagnosis functions overview.....	54
6.6.2	Status message categories.....	55
6.6.3	Checking the status.....	56
6.6.3.1	Menu "Status".....	56
6.6.3.2	Measured value status.....	56
6.6.3.3	Module status.....	57
6.6.3.4	Limit values status.....	57
6.6.4	Displaying the logbooks.....	58
6.6.5	Adjustment/validations results.....	59
6.6.5.1	Viewing adjustment results.....	59
6.6.5.2	Viewing validation results.....	60
6.7	Configuring.....	60

6.7.1	Setting the internal clock.....	60
6.7.1.1	Setting the date.....	60
6.7.1.2	Setting the time.....	61
6.7.2	Configuring the test gases.....	61
6.8	Measuring point switchover (measuring point automatic).....	62
6.9	Configuring measuring point switchover.....	62
6.9.1	Configuring a measuring point.....	62
6.9.2	Assigning a status output for the switchover phase.....	64
6.9.3	Selecting the measuring point display.....	64
6.10	Language.....	64
7	Maintenance.....	66
7.1	Important information.....	66
7.2	Tube screw fitting.....	67
7.3	Maintenance plan.....	68
7.4	Check.....	69
7.5	Maintenance of gas sampling probe.....	69
7.6	Cooler maintenance.....	70
7.7	Replacing hose and wrapping tape of the hose pump	71
7.8	Check and replace the sample gas fine filter	72
7.9	Check and replace the water trap.....	73
7.10	Leak tightness check.....	73
8	Troubleshooting.....	76
8.1	Important information.....	76
8.2	Malfunctions (Table)	77
8.3	Removing and fitting the sampling probe.....	78
8.4	Replacing the heated sample gas line.....	79
8.5	Replacing the sample gas pump.....	81
8.6	Replacing the solenoid valve	82
8.7	Replacing the sample gas cooler.....	83
8.8	Replacing the power supply unit of the distribution unit.....	84
8.9	Replacing the analyzer door.....	84
8.9.1	Replacing the control unit (BCU) an analyzer door.....	84
8.9.2	Replacing the bottom analyzer door.....	85
8.10	Replacing the analyzer.....	86
8.11	Replacing the analyzer power supply unit.....	87
8.12	Analyzer fuse.....	88
8.13	Replacing the CO ₂ module (FINOR).....	88
8.14	Replacing the O ₂ module (OXOR E).....	90
8.15	Replacing the gas module.....	91
8.16	Removing and fitting the complete analyzer module.....	92
9	Decommissioning.....	94
9.1	Stand-by and switching off.....	94
9.2	Protective measures for long-term storage.....	95

9.3	Shipping for repair.....	95
9.4	Transport.....	95
9.5	Disposal.....	96
10	Technical data.....	97
10.1	Dimensional drawings.....	97
10.1.1	Dimensional drawing of sample conditioning.....	97
10.1.2	Dimensional drawing of distribution unit.....	98
10.1.3	Dimensional drawing of analyzer.....	99
10.1.4	Dimensional drawing of sampling probe.....	100
10.1.5	Sample gas line, heated.....	100
10.2	Gas flow diagram.....	101
10.3	Measuring parameters.....	103
10.4	Ambient conditions.....	103
10.5	Sample gas conditions.....	104
10.6	Design as wall enclosure.....	104
10.7	Sample gas line, heated.....	105
10.8	Interfaces and protocols.....	105
10.9	Energy supply.....	106
10.10	Emissions.....	107
10.11	Torques for screw fittings.....	107
10.12	Tube connections.....	108
10.13	Sample gas conditions.....	108
11	Annex.....	109
11.1	Logbook messages.....	109
11.1.1	Measured value assignment (MVx) (example).....	109
11.1.2	Logbook messages.....	109
11.2	Consumable parts, wearing parts and spare parts.....	116
11.3	Compliances.....	118

1 About this document

1.1 Function of this document

These Operating Instructions describe:

- System components
- Start-up
- Operation
- Maintenance work required for reliable operation
- Troubleshooting

1.2 Target group

This document is addressed to technicians (persons with technical understanding) operating and maintaining the measuring system.

Responsibility of the operator

- Use the device only as described in these Operating Instructions; the manufacturer assumes no responsibility for any other use.
- Perform the specified maintenance work.
- Do not remove, add or change any components in or on the device unless such changes are officially allowed and specified by the manufacturer.
 - Otherwise the manufacturer's warranty becomes void.
 - Otherwise the device could become dangerous.
- Observe special local conditions.
 - Follow all local laws, regulations and company-internal operating directives applicable at the respective installation location.
- Retain documents. These Operating Instructions:
 - Must be kept available for reference.
 - Must be conveyed to new owners.

Requirements for the maintenance personnel

- The technician must be familiar with the exhaust gas technology of the operator's plant (overpressure, toxic and hot sample gases) and be able to avoid hazards when working on gas ducts.
- The technician must be familiar with handling compressed gas cylinders (test gases).
- The technician must be able to avoid hazards caused by noxious test gases.
- The technician must be familiar with gas lines (PTFE lines) and their screw fittings (be able to ensure gas-tight connections).
- Only allow an authorized electrician to work on the electrical system or electrical subassemblies.

1.3 Further information







- Technical Information MARSIC200
- Technical Information BCU
- Sampling Probe Operating Instructions
- Instructions for laying the sample gas line
- Sample Gas Cooler Operating Instructions
- BCU Operating Instructions
- Modular System I/O Operating Instructions
- Optional: MPR (Meeting Point Router) Operating Instructions
- Gas Valve Operating Instructions

- System documentation
- Product CD

1.4 Symbols and document conventions

1.4.1 Warning symbols

Table 1: Warning symbols

Symbol	Significance
	Hazard (general)
	Hazard by voltage
	Risk of explosion
	Hazard by acidic substances
	Hazards by noxious substances
	Hazard by high temperature
	Hazard for the environment/nature/organic life

1.4.2 Warning levels / Signal words

DANGER

Risk or hazardous situation which will result in severe personal injury or death.

WARNING

Risk or hazardous situation which could result in severe personal injury or death.

CAUTION

Hazard or unsafe practice which could result in less severe or minor injuries.

Notice



Hazard which could result in property damage.

Note

Hints

1.4.3 Information symbols

Table 2: Information symbols

Symbol	Significance
	Important technical information for this product
	Important information on electric or electronic functions

1.5 Intended use

MARSIC serves emission monitoring on maritime combustion engines.

1.5.1 Installation location

- Observe the regulations and Operating Instructions valid on board.
- Operate MARSIC only below deck in well ventilated rooms.



WARNING

Risk of explosion in potentially explosive atmospheres

- ▶ Do not operate the device and its subassemblies in potentially explosive atmospheres.
-

2 Product description

2.1 Product identification

Product name	MARSIC200
Manufacturer	SICK AG Erwin-Sick-Str. 1 · 79183 Waldkirch · Germany
Type plates	<ul style="list-style-type: none">• On sample conditioning, distribution unit, analyzer: On the enclosure outside• On other system assemblies: See the Operating Instructions of the system assembly

2.2 Gas supply terminology

Definition of the gases used:

- Zero gas: Gas used to adjust the zero point. Instrument air or nitrogen (N₂).
- Span gas: Gas used to adjust the upper measuring range value.
- Test gas: Generic term for zero and span gas.
- Instrument air: Clean compressed air.

Quality of gases: [see "Sample gas conditions", page 108.](#)

2.3 Layout and function

System overview

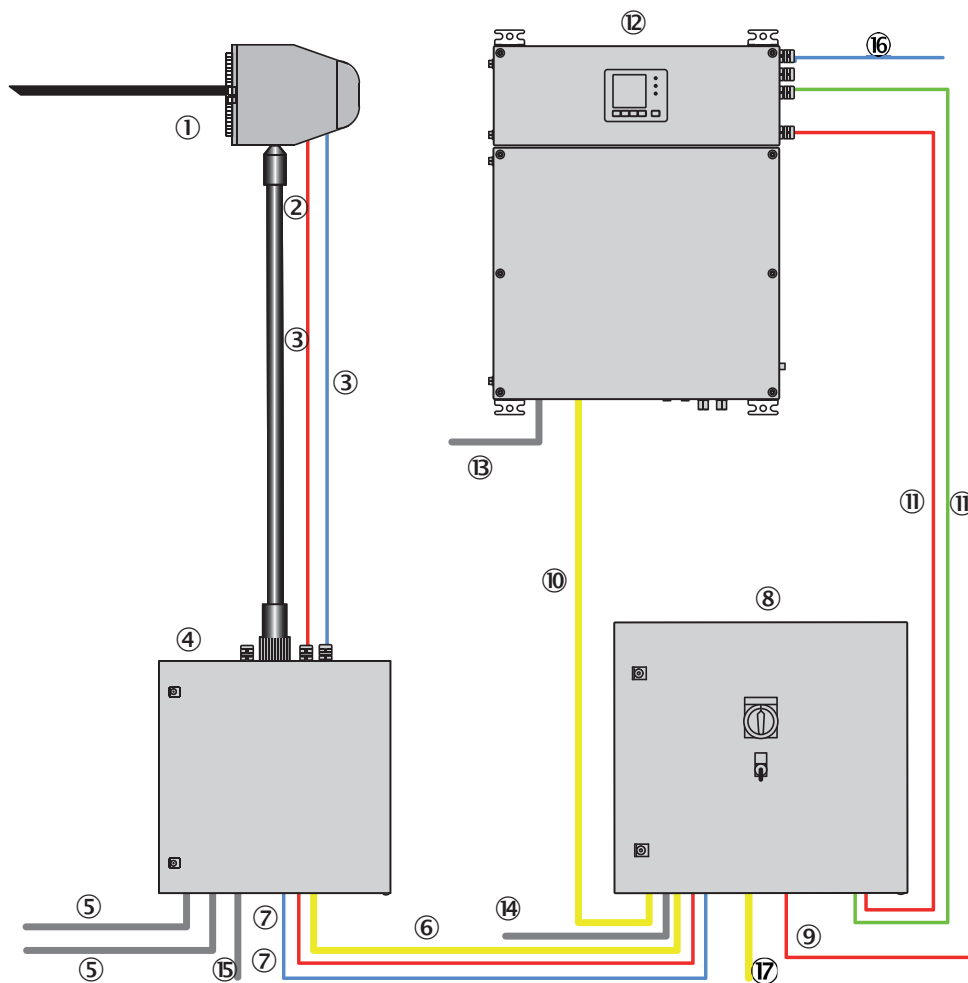

Figure 1: System overview (schematic, cable inlets only approximate)

Red Power supply
 Blue and green Signal line
 Yellow PTFE gas line

①	Heated sampling probe with: <ul style="list-style-type: none"> • Sampling tube • Sample gas filter • Backflushing 	see "Sampling probe", page 14
②	Heated sample gas line, sampling probe - sample conditioning: <ul style="list-style-type: none"> • Sample gas • Instrument air/test gas (optional) 	see "Sample gas line, heated", page 15
③	Lines, sampling probe - sample conditioning <ul style="list-style-type: none"> • Power supply of the sampling probe • Signal line 	Observe the quality of the operator's instrument air: see "Sample gas conditions", page 108

④	Sample conditioning with: <ul style="list-style-type: none"> • Sample gas cooler • Solenoid valve for feeding instrument air/test gas to the sampling probe 	see "Sample conditioning", page 15
⑤	Gas inlets of sample conditioning: <ul style="list-style-type: none"> • Instrument air to backflush the probe and for zero point adjustment • Test gas for adjustment via probe (optional) 	Observe the quality of the operator's instrument air: see "Sample gas conditions", page 108
⑥	Unheated sample gas line, sample conditioning - distribution unit	
⑦	Lines, sample conditioning - distribution unit: <ul style="list-style-type: none"> • Power supply of sample conditioning • Signal line 	
⑧	Distribution unit with: <ul style="list-style-type: none"> • Power supply, complete system with central power distribution • System fuses • Main switch • "Stand-by" switch • Flow indicator • Sample gas fine filter • Water trap • Sample gas pump • Sample gas valve (test gas feed optional) • Measuring point switchover (for 2 ... 4 measuring points) • Bypass pump (for 2 ... 4 measuring points) 	see "Distribution unit", page 17
⑨	Inlet for central power supply for the complete system <ul style="list-style-type: none"> • The distribution unit provides electrical power for all system modules. 	
⑩	Unheated sample gas line from distribution unit to analyzer	
⑪	Lines, distribution unit - analyzer: <ul style="list-style-type: none"> • Analyzer power supply • Signal lines 	
⑫	Analyzer <ul style="list-style-type: none"> • Control unit • Measuring modules • Analog and digital interfaces 	see "Analyzer", page 18
⑬	Sample gas outlet of the analyzer	
⑭	Test gas inlet Test gas connection during adjustment	
⑮	Condensate outlet	
⑯	Signal lines/Ethernet to periphery	
⑰	Exhaust gas outlet of advance extraction (for 2 ... 4 measuring points)	

Measuring principles

- SO₂, NO, NO₂: NDUV measuring principle
- CO₂: NDIR measuring principle
- O₂: Electrochemical measuring principle (option)

Measuring components/versions

- DeSO_x measurement
 - SO₂, CO₂, optional O₂
- Emission monitoring, complete (DeNO_x)
 - SO₂, CO₂, NO, NO₂, optional O₂
- Customer-specific version

See the enclosed system documentation for the configuration of your system.

Function

The system operates independently.

- Sampling and filtering the sample gas at the measuring point with a heated sampling probe.
- Feeding the hot sample gas to the sample conditioning (1 sample conditioning per measuring point) in a self-regulating, heated sample gas line.
- Removing moisture by cooling the sample gas in the sample conditioning.
- Suctioning the dry sample gas in the distribution unit, further filtering and feeding to the analyzer.
- Measuring gas conditions and sample gas components in the analyzer and providing the measured values.
- Output of measured values via analog and digital outputs (configurable).
- With several measuring points, a bypass pump extracts the sample gas in advance from the measuring point to be measured next.
This ensures the exhaust gas to be measured is fed quickly to the analyzer when the measuring point is switched.

The operating states are signaled by status signals and entered in a logbook ([see "Logbook messages", page 109](#)).

Adjustments

Zero point adjustment is performed automatically (in addition, manually) with instrument air or nitrogen: [see "Zero point adjustment", page 26](#).

Reference point adjustment is performed manually with span gas feed via the gas sampling system or via the distribution unit: [see "Reference point adjustment", page 26](#).

Measuring point switchover

Measuring point switchover allows using up to 4 measuring points.

Configurable for each measuring point:

- Name of the measuring point (freely selectable identifier)
- Flush time (wait time after switchover before the measured value is output)
- Measuring time (duration of measurement on the measuring point)
- Digital output to control the switchover

Configuration: See "Technical Information MARSIC200" Chapter "Configuring measuring point switchover".

When several measuring points are active, the measured value for the active measuring point is provided as well as the measured values for the inactive measuring points.

The measuring component, measuring point and the last measured value are displayed in the menus for measured value displays.

Holding the measured value:

- When one measuring point is activated, the measured values for this measuring point correspond to the current measured value (after the flush time).
- During the time other measuring points are activated, the measured value last measured at the measuring point is displayed constantly as measured value for this measuring point (sample-and-hold amplifier function).

This also functions with analog outputs which output the measured value of a measuring point.

Operation via control unit

- Operation is performed via the control unit in the analyzer door: [see "Operation", page 23](#).

Operation via external PC

Operator menus and measured value displays are also available on an external PC via the Ethernet connection (with the SOPAS ET engineering tool).

You can download SOPAS ET free of charge from the SICK website.

Further information, see "Technical Information MARSIC200".

Interfaces

- Modbus (TCP/IP)
More information on Modbus, see "Operating Instructions BCU".
- Analog and digital inputs and outputs

2.3.1 Sampling probe

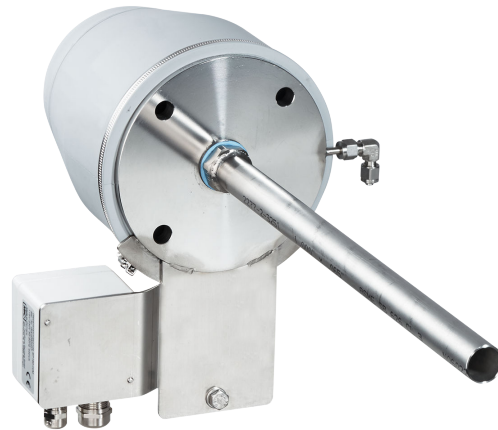

Figure 2: Sampling probe (system-specific)

- The sampling probe extracts the sample gas from the exhaust duct
- The sampling probe is thermostatic-controlled and self-regulating
- When the temperature drops below a certain limit, a corresponding status signal is shown in the analyzer
- When the complete system is free from voltage, the sampling tube is flushed with instrument air
- Scheduled maintenance: [see "Maintenance plan", page 68](#)



NOTE

The sampling probe is system-specific

- ▶ Further information on the sampling probe, see Operating Instructions of the sampling probe
-

2.3.2 Sample gas line, heated

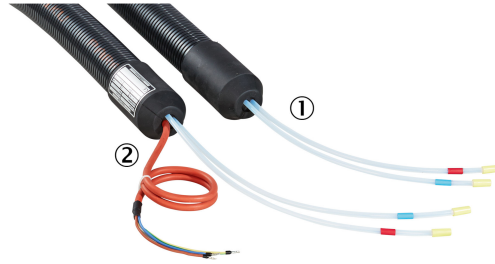

Figure 3: Heated sample gas line

① Sampling probe connection side:

- Gas connection: DN4/6
- No electric lines
- Line for sample gas (red ring)
- Line for instrument air (blue ring)

② Sample conditioning connection side:

- Gas connection: DN4/6
 - Electric connection to sample conditioning
 - Line for sample gas (red ring)
 - Line for instrument air (blue ring)
- The heated sample gas line leads the sample gas from the sampling probe to the sample conditioning
 - The sample gas line is thermostatic-controlled and self-regulating to 120 °C to prevent condensation in the sample gas
 - There is no temperature setting or indicator
 - ▶ To check whether the sample gas line is heating:
 - The sample gas line must be clearly warmer than the ambient temperature

2.3.3 Sample conditioning

The hot sample gas is cooled down during sample conditioning in a sample gas cooler and therefore dried, and then passed to the distribution unit.

1 sample conditioning is present for each measuring point.

Any condensate occurring is drained off via a hose pump.

The sample conditioning has a purge gas valve for feeding instrument air to the sampling probe (for zero point adjustment and purging the probe when the system is switched off).



Figure 4: Sample conditioning (exterior view)

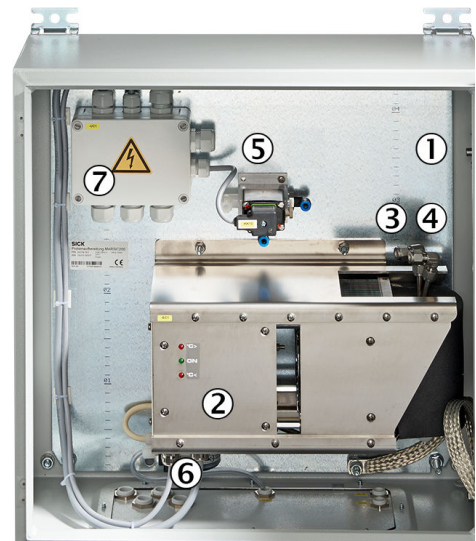

Figure 5: Sample conditioning (interior view, the sample gas cooler is system-specific)

①	Enclosure duct for heated sample gas line	
②	Sample gas cooler	A “Group malfunction” status signal is sent to the analyzer and evaluated there. For further information concerning the sample gas cooler, see the Operating Instructions of the sample gas cooler.
③	Sample gas inlet, cooler Connection: DN 4/6	The line marked red of the heated sample gas to the sampling probe is connected here
④	Sample gas outlet, cooler Connection DN 4/6	The unheated sample gas line to the distribution unit is connected here
⑤	Solenoid valve KK10, outlet “A” Connection: DN 4/6	Connect the line of the heated sample gas line marked blue to the sampling probe here
	Solenoid valve KK10, inlet “P” Connection: DN4/6	Connection for external test gas cylinder to adjust the sampling probe
	Solenoid valve KK10, inlet “R” Connection: DN4/6	Connection for external instrument air for zero point adjustment and to backflush the sampling probe
	LED	The valve is activated during measuring operation and the LED is on
⑥	Hose pump with condensate outlet	Collect or drain off condensate occurring at the condensate outlet in a suitable manner
⑦	Terminal box	Power supply for sampling probe, sample gas line and sample conditioning (comes from the distribution unit) Status signals from sampling probe and sample gas cooler (goes to analyzer)

Acid condensate escapes from the condensate outlet.

- ▶ Make sure the condensate is safely collected or drained off
- ▶ The hose end can end max. 10 m above the condensate outlet
- ▶ Maintenance see "[Maintenance plan](#)", page 68



CAUTION

Risk of chemical burns by acid medium

- ▶ Take appropriate protective measures for work (for example, by wearing a safety mask, protective gloves and acid resistant clothes).
- ▶ In case of contact with the eyes, rinse immediately with clear water and consult a doctor.

2.3.4 Distribution unit

The distribution unit is the central power supply for the complete system and contains the sample gas pump and the measuring point switchover (for 2 .. 4 measuring points).

There is only 1 (central) distribution unit independent of the number of measuring points.



CAUTION

When switched off prematurely, there is a risk of contamination by sample gases remaining in the sample gas path

- ▶ Follow the switch-off procedure (see "Stand-by and switching off", page 94) and do not completely switch the system off immediately

View

MULTI version distribution unit for two to four measuring points (example)



Figure 6: Distribution unit (exterior view)

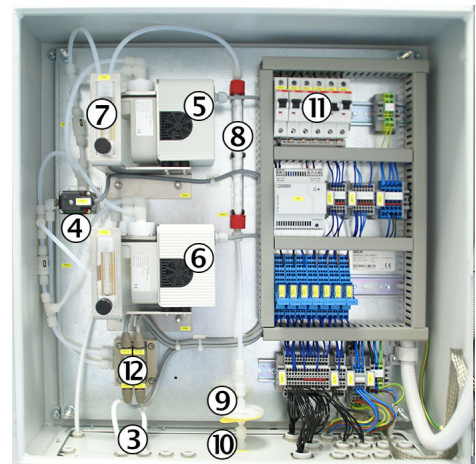

Figure 7: Distribution unit (interior view system-specific)

<p>① Main switch ON: Voltage is on OFF: Voltage is off</p>	<p>Main switch set to "OFF":</p> <ul style="list-style-type: none"> • Sample conditioning voltage: "OFF" • Sampling probe voltage: "OFF" <ul style="list-style-type: none"> ◦ The purge air valve is "open when no current is applied": The sampling tube is flushed with instrument air • Sample gas line heating: "OFF" • Analyzer voltage: "OFF" <p>Main switch set to "ON":</p> <ul style="list-style-type: none"> • All voltages come on.
--	---

②	<p>“Stand-by” switch OFF: Regular operation ON: Stand-by</p>	<p>“Stand-by” switched to ON:</p> <ul style="list-style-type: none"> • The maintenance signal on the analyzer becomes “active” and the yellow LED lights • The measured values continue to “live” • A zero point validation is performed • The sample gas pump and the (optional) bypass pump go off • The heaters remain switched on • The sampling tube is flushed with instrument air <p>“Stand-by” switched to OFF:</p> <ul style="list-style-type: none"> • Sample gas pump and the (option) bypass pump are switched on • The system goes into measuring operation: Only the green LED lights on the analyzer
③	Sample gas inlet from sample conditioning(s)	
④	Solenoid valve KK1, inlet “R” Connection: D/N 4/6	Sample gas inlet For 1 measuring point: From sample conditioning For 2 ... 4 measuring points: From measuring point switchover in distribution unit
	Solenoid valve KK1, inlet “P” Connection: D/N 4/6	Test gas inlet During test gas adjustment with gas feed on the distribution unit, the test gas is passed directly to the analyzer.
	Solenoid valve KK1, outlet “A” Connection: D/N 4/6	Gas outlet to analyzer
⑤	Sample gas pump	For extraction of the respective active measuring point
⑥	Bypass pump	For advance extraction of the sample gas for 2 ... 4 measuring points
⑦	Flow indicator with adjustment wheel	Setpoint flow rate: Approx. 60 l/h. The flow is displayed as measured value on the analyzer.
⑧	Sample gas fine filter	Serves to filter the sample gas for all measuring points before feeding to the analyzer. The analyzer signals the flow is too low when the filter clogs up.
⑨	Water trap	The water trap protects the analyzer against damp sample gas. The analyzer signals the flow is too low when the filter clogs up.
⑩	Sample gas outlet to analyzer	
⑪	Fuse 1	24 V power supply unit
	Fuse 2...5	1 fuse per measuring point (probe, line, sample conditioning)
	Fuse 6	Sample gas pump
	Fuse 7	Bypass pump (as from 2 measuring points)
	Fuse 8	Analyzer
⑫	Measuring point switchover	

2.3.5 Analyzer

The analyzer comprises:

- Control unit
- Measurement technology
- Analog and digital interfaces

View



Figure 8: Analyzer (exterior view)

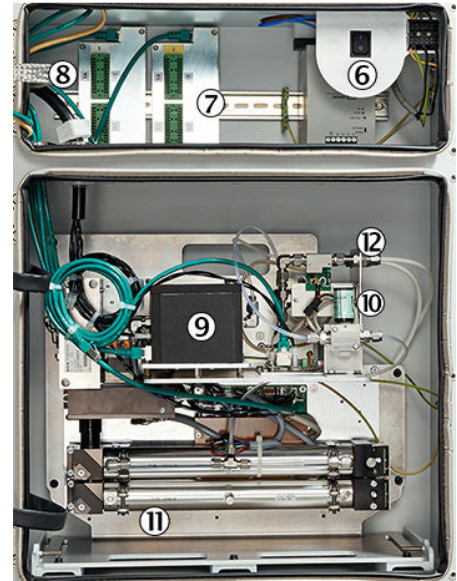

Figure 9: Analyzer (interior view)

①	Analyzer top part with electronics	
②	Control unit	see "Operating and display elements", page 23
③	Analyzer bottom part with measurement technology	
④	Sample gas inlet	Screw fitting: DN4/6 stainless steel
⑤	Sample gas outlet	Screw fitting: DN4/6 stainless steel
⑥	On/Off switch	The On/Off switch switches the analyzer on/off.
⑦	Data interfaces	Analog and digital inputs and outputs
⑧	Fuse	see "Analyzer fuse", page 88
⑨	Measuring module CO ₂ (FINOR)	
⑩	Measuring module O ₂ (OXOR E)	
⑪	Measuring module SO ₂ /NO/NO ₂ (DEFOR)	
⑫	Measuring module flow/humidity/pressure (gas module)	

2.4 Remote maintenance (optional)

The SICK Meeting Point Router (MPR) is available for remote diagnostics via the internet.

The MPR links a plant-side machine network with the SICK remote architecture.

A firewall which decouples the machine network from the internet or the operating company network is integrated in the MPR.



NOTE

An internet connection must be available

Further information, see attached "Operating Instructions MPR".

3 Commissioning

3.1 Before switching on



NOTICE

Installation and initial start-up, see "Technical Information MARSIC200".

Before switching on ...

- Perform a visual check: see "Check", page 69.
- When the measuring system has not been in operation for an extended period of time or work on the sample gas path has been performed.
- Zero gas supply must be connected to the sample conditioning and to the distribution unit.
 - If the instrument air feed has changed: Check the instrument air quality. Specified quality: see "Sample gas conditions", page 108.

3.2 Switching on



NOTICE

Installation and initial start-up, see "Technical Information MARSIC200".

View

SINGLE version distribution unit for one measuring point (example)



Figure 10: Switches at distributor unit

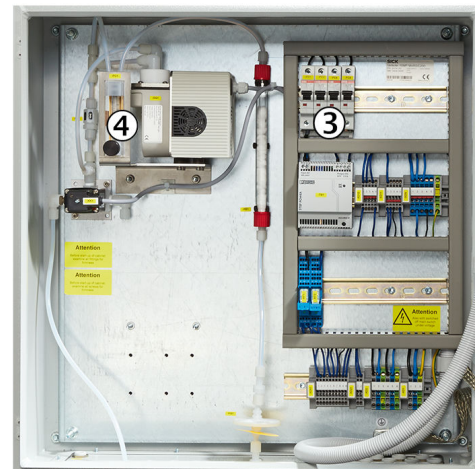

Figure 11: Fuses in distributor unit

- ① Main switch
- ② Stand-by switch
- ③ Fuses
- ④ Flowmeter

Switching on

1. Switch on the external power disconnection unit.
2. Set the Stand-by switch on the distribution unit to **OFF** (normal operation).
3. Switch on all fuses in the distribution unit.
4. Set the main switch on the distribution unit to **ON**.
5. The LEDs light and **Booting** is displayed on the control unit.

If this is not the case: Check the power supply (e.g., main power switch in the analyzer).

- ✓ The LEDs on the control unit light alternately, the measured values blink.
- ✓ This state is maintained for approx. 2 h until the system has heated up.
- 6. The system performs an automatic zero point adjustment.
- 7. The **yellow** LED goes off.
The **green** LED goes on, the measured values have stopped blinking and **MEASURING** is shown on the display.
- 8. Check the flow on the flowmeter (in the distribution unit): Approx. 60 l/h. Set on the flowmeter when necessary.
- 9. Check that only the **green** LED lights on the control unit.
 - When the yellow or red LED is on: Press the "DIAG" button and/or check the logbook.
- 10. Perform a leak tightness check: [see "Leak tightness check", page 73](#).
- 11. Close all open enclosures.
- 12. Check the time. Set the time, if required: [see "Setting the internal clock", page 60](#).
- ✓ The system is in operation.

3.3 Recognizing the safe operating state

The system is in safe operation when:

- The power supply is within the specification: [see "Energy supply", page 106](#).
- Clean instrument air according to the specification has been connected and is applied: [see "Sample gas conditions", page 108](#).
- A leak tightness check was performed successfully ([see "Leak tightness check", page 73](#)).
- The flow is approx. 60 l/h (see flowmeter in the distribution unit).
- All enclosure doors are closed.
- Only the **green** LED lights on the display.
- The measured values are plausible.

4 Operation

4.1 Operating and display elements

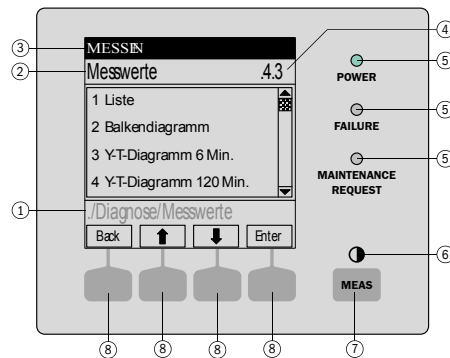

- ① Current menu branch
- ② Current menu
- ③ Status bar
- ④ Menu number
- ⑤ LEDs
- ⑥ Contrast: Press the **MEAS** button for several seconds
- ⑦ **MEAS** button: Measuring screen
- ⑧ Function button (function is displayed)
ENTER
MENU, etc.





NOTICE

The display lighting can possibly switch off automatically after a certain time.

- ▶ Reactivating the display lighting: Press the left or right function button.

4.1.1 LEDs

LED	Significance/ possible causes
 POWER	The device is switched on, power voltage is available
 FAILURE	At least one status flag ¹ F is activated
 MAINTENANCE REQUEST	At least one status flag ¹ M, C or U is activated for at least one measured value, analyzer module or sensor The Maintenance mode state is activated manually (see "Maintenance mode", page 33)

¹ Explanation (see "Status message categories", page 55)

4.1.2 Function buttons

Button	Function
MEAS	Return to the Measuring screen from any menu: see "Measuring screen", page 24 <ul style="list-style-type: none"> • Press <Save> to store any changes made. Otherwise the changes are lost
	To set the contrast: Press the MEAS button for more than 2 seconds

The respective function of the function buttons is shown on the display.

Display	Function
Back	Return to the higher level menu. Press <Save> to store any changes made. Otherwise the changes are lost.

Display	Function
Diag	Diag is shown only when there is a message. To display the message: Press this button.
Enter	Call up/start selected menu function
Menu	Call up the main menu. If the <Menu> button is not shown: Press MEAS first.
Save	Save input/exit
Set	Start setting
Select	Select function/character
Start	Start procedure
↑	In a selection list: Move cursor upwards During input: Next character
↓	Move cursor downwards
←	Move cursor to the left
→	Move cursor to the right

4.2 Measuring screen

Use the MEAS button to go to the Measuring screen.

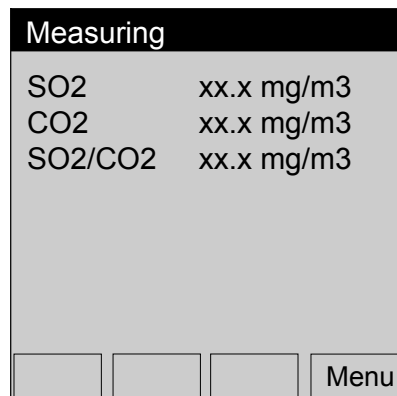

4.3 Display lighting

It is possible that the display lighting switches off automatically.

- ▶ When the display is dark: Press the left or right function button.
- ▶ If this does not work: Check whether the device is on (**POWER** lights) or if power voltage is available.

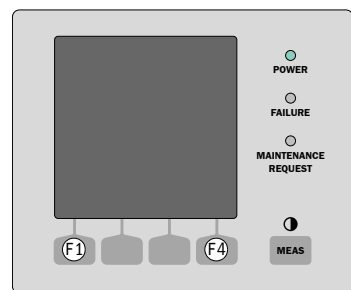

F1 Left function button
F4 Right function button

Figure 12: Reactivating function buttons for automatic light-off

4.4 Internal clock buffer time

When sequences exist that are started by the internal clock (e.g., automatic adjustments):

- ▶ If the device has been out of operation for more than 3 ... 5 days: Set the internal clock again after start-up, see ["Setting the internal clock", page 60](#).

5 Adjustment with zero and span gas

Quality of test gases: see "Sample gas conditions", page 108

For the adjustment, the zero point is adjusted first and then the end value of the respective measuring range and the respective gas component.

Analog outputs

During an adjustment, the analog outputs are held with the last current measured values (default setting. See "Technical Information MARSIC200" for setting).

5.1 Zero point adjustment

For the zero point adjustment, the zero gas is always fed via the distribution unit.

The zero point adjustment is performed with nitrogen (N₂) or clean compressed air (instrument air).

Only nitrogen (N₂) can be used for zero point adjustment of oxygen (O₂) (optional).

Zero point adjustment can be performed automatically and also manually, as well.

- Automatic zero point adjustment:
 - After switching the power supply on
 - Interval: Once per week (preset. Setting: See "Technical Information MARSIC200")This is also performed in the "Stand-by" state

5.2 Reference point adjustment

Reference point adjustment is always performed manually.

Adjustment interval: see "Maintenance plan", page 68

There are two methods for reference point adjustment:

Reference point adjustment via the sampling probe

During reference point adjustment with gas feed via the sampling probe, the complete system is involved in the adjustment.

- Gas feed runs via the solenoid valve into the sample conditioning of measuring point 1 and flows through the backflush line in the heated sample gas line on the sampling probe.
- The span gas is suctioned into the system and excess test gas flows out via the sampling pipe.

Reference point adjustment via the distribution unit

During test gas adjustment with gas feed on the distribution unit, the test gas is fed directly to the analyzer.

- Gas is fed to the solenoid valve in the distribution unit and then passed directly to the analyzer via the unheated sample gas line.



NOTICE

Disconnect the reference gas after adjustment and reconnect the zero gas. Otherwise test gas flows through the system during zero point adjustment.

5.3 Performing the adjustment

For the adjustment, the zero point is adjusted first and then the end value of the respective measuring range and the respective gas component.

For the zero point adjustment, the zero gas is always fed via the distribution unit.

When the adjustment starts, the sample gas pump runs, the test gas is fed and the gas flow starts. The flow rate should be about 60 l/h. Observe the flow rate and, when necessary, adjust the primary pressure of the test gas to reach the required flow rate.

Further information on operation:

- When using SOPAS ET: See Chapter “Adjustment” in “Technical Information MARSIC200”.

5.3.1 Connect zero or span gas

1. Connect zero gas

Use zero gas (instrument air or nitrogen) for zero point adjustment.

Connect the zero gas to inlet “P” of solenoid valve KK1 in the distribution unit (max. 300 mbar overpressure).

- ④ Valve KK1
- ⑦ Flowmeter

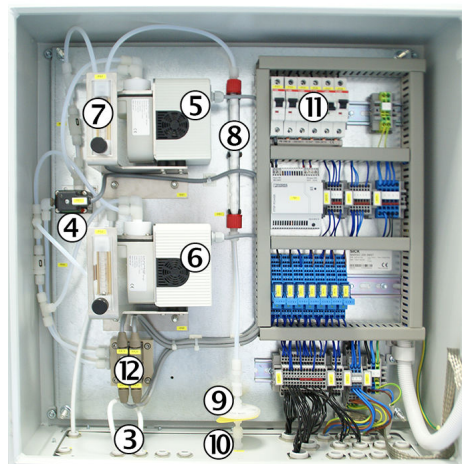

Figure 13: MULTI version distribution unit for two to four measuring points (example)

2. Connect span gas for span point adjustment

There are two options for span point adjustment:

- OPTION A: Direct analyzer adjustment without “detour” via gas sampling and sample conditioning.
- OPTION B: Adjustment of the complete system including gas sampling system and sample conditioning (measuring point 1 only).

Calibration gas is fed on different gas inlets of the MARSIC200 depending on the “option A” or “option B” used.

- **OPTION A: Connect span gas to the distribution unit**

Direct analyzer adjustment without gas sampling and sample conditioning. Calibration gas connection to inlet “P” of solenoid valve KK1 in the distribution unit (max. 300 mbar overpressure).

Zero gas is connected as standard, span gas is fed manually by disconnecting the zero gas supply and replacing it by test gas.

Details: see “Layout and function”, page 11 and see “Distribution unit”, page 17.

Gas feed setting in the BCU menu: “RefGasNotOnProbe” (see further down: “Span gas feed configuration”).

- ④ Valve KK1
- ⑦ Flowmeter

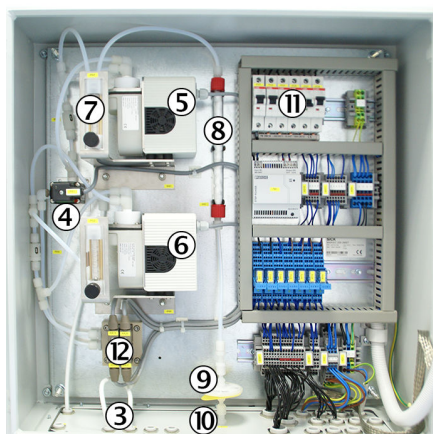

Figure 14: MULTI version distribution unit for two to four measuring points (example)

- **OPTION B: Connect span gas to the sample conditioning**
Adjustment of the complete system including sampling and sample conditioning (only possible on sample gas point 1).
Span gas connection to inlet “P” of solenoid valve KK10 in the sample conditioning (max. 300 mbar overpressure).
Details: see "Layout and function", page 11 and see "Sample conditioning", page 15.
Gas feed setting in the BCU menu: “RefGasOnProbe” (see further down: “Span gas feed configuration”).



NOTE

Excess test gas is discharged via the probe tube. This can lead to high test gas consumption.

Therefore only turn the test gas up so far until the measured value displayed has just become stable.

When the complete system is adjusted via the probe, flush times may have to be adjusted in order to flush the complete gas sampling path.

- ⑤ Valve KK10

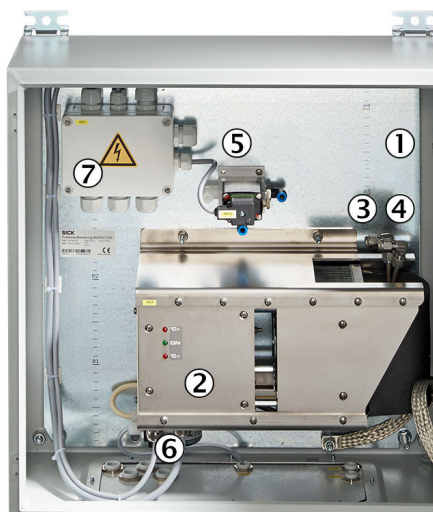

Figure 15: Sample conditioning

5.3.2 Configuration in menu

1. Login using menu Login/MARSIC with password “EMI”.
2. Span gas feed configuration.

Select where the calibration gas is to be fed:

- o Menu: Parameter/Special fct./Customer fct.

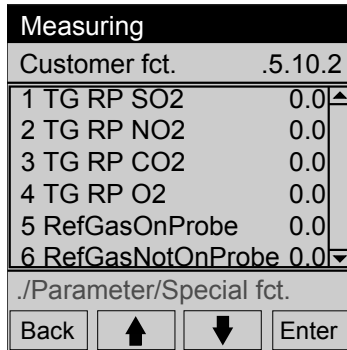

TG = Test gas

RP, conc. = Reference point (test gas concentration)

“0.0” is shown as concentration.

Select the required test gas to set the test gas concentration

Figure 16: Menu Parameter/Special fct./Customer fct.

- o OPTION A: RefgasNotOnProbe
Gas feed direct to the analyzer, gas connection on the solenoid valve in the **distribution unit** (see OPTION A further upwards).
 - o OPTION B: RefGasOnProbe
Gas feed via the probe, gas connection on the solenoid valve in the sample conditioning (see Item 2, option B).
(Only possible for measuring point 1)
3. Configure the test gases
 - o Menu: Adjustments/Settings/Test gases/Test gas setting/Usage
Test gas selection and configuring the associated gas concentrations in accordance with the specifications on the Gas Certificate on the test gas cylinder.

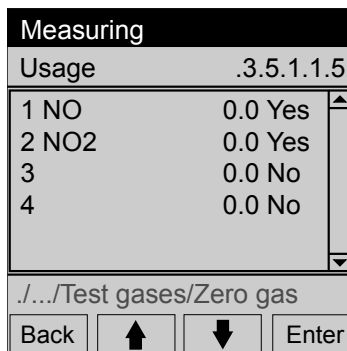

- 1 Selected measuring component | Set-point (Concentration) | Usage
- 2 Selected measuring component | Set-point (Concentration) | Usage
- 3 Unused
- 4 Unused

5.3.3 Start the adjustment

1. Start the adjustment
Basically, two options are available for component adjustment (zero point and span point):
 - o Option 1: Each individual component can be adjusted.
 - o Option 2: Simultaneous adjustment of several components.

Information:

If the component oxygen (O₂) is present in the system, nitrogen (N₂) must be used for a common zero point adjustment of all components (otherwise individual adjustment).

For a simultaneous span point adjustment, make sure all gas components used are in one gas cylinder (e.g., CO₂ and SO₂ in one gas cylinder) and the concentrations have been entered accordingly (see Item above).

5.3.3.1 Adjusting one component

This menu is only accessible in user level “Authorized operator”) (password, see “Technical Information MARSIC200”).

- 1 Menu: Adjustments/Adjustment.
- 2 Select the component to be adjusted (NO as example here) and start the validation (check only, no adjustment) or adjustment.

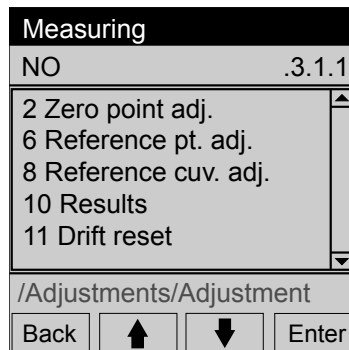

- 3 A prompt appears for the desired adjustment procedure:

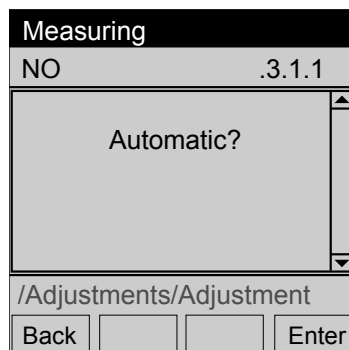

- | | |
|-------|---------------------------------------|
| Enter | Starts the automatic adjustment |
| Back | Starts the user-controlled adjustment |

- With preset time sequences (i.e. “automatic”). Further information, see ["Setting an automatic adjustment start", page 44.](#)
 - User controlled (i.e. “step for step”). Further information see ["User-controlled adjustment", page 38.](#)
- After the adjustment procedure starts, the yellow status LED is on and **ACTIVE** shown.
 - After successful adjustment, the yellow status LED goes off and the system is ready for measuring operation.
The yellow LED or the red LED remains on when an error occurs. The status bar displays **SEE LOGBOOK.**

5.3.3.2 Adjusting several components

Note: Always perform a zero point adjustment before a span point adjustment.

- 1 Menu: Adjustments/Group function
Adjustment procedures suitable for the device are available.
These can be adapted individually, see ["Adjustment/validation of several components \(group function\)", page 44](#)
Start the validation (check only, no adjustment) or adjustment.

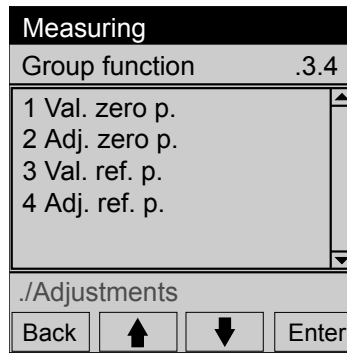

- 1 Validation (check) zero point
- 2 Adjustment (check and set) zero point
- 3 Validation (check) reference point
- 4 Adjustment (check and set) reference point

- After the adjustment procedure starts, the yellow status LED is on and **ACTIVE** shown.
- After successful adjustment, the yellow status LED goes off and the system is ready for measuring operation.
The yellow LED or the red LED remains on when an error occurs. The status bar displays **SEE LOGBOOK**.

6 Menus

6.1 Menu tree

O = This menu is visible for the “Operator” user levels
 M = This menu is additionally visible for the “MARSIC” user level
 A = Authorized operator (password see “Technical Information MARSIC200”)

Menu level	O/M	Explanation
Login	O	chapter 6.3
Auth. operator	O	See “Operating Instructions BCU”
Service	O	Service
Logout	O	chapter 6.3
MARSIC	O	chapter 6.3
Maintenance	M	see "Maintenance functions", page 33
Maintenance mode	M	chapter 6.4.1
Reset BCU	M	chapter 6.4.2
Adjustments	M	chapter 6.5
Adjustment	A	Adjustment of single components chapter 6.5.1
Group functions	M	Start adjustment manually see "Adjustment/validation of several components (group function)", page 44
Settings	M	---
Test gases	M	see "Configuring test gases", page 48
Diagnosis	O	chapter 6.6
Status	O	chapter 6.6.3
Meas. values	O	chapter 6.6.3.2
Modules	O	chapter 6.6.3.3
Limit values	O	chapter 6.6.3.4
Logbooks	O	chapter 11.1
Logbook compl.	O	
Logbook F, M, C, U, E	O	
Results	O	chapter 6.6.5
Adjustment results	O	chapter 6.6.5.1
Validation results	O	chapter 6.6.5.2
Parameters	M	chapter 6.7
Date - Time	M	chapter 6.7.1
Special fct.	M	
Customer fct.	M	Configuration of test gases chapter 6.7.2
Language	O	chapter 6.10

6.2 Main menu

Use function button **Ⓢ**-MENU to go to the main menu.

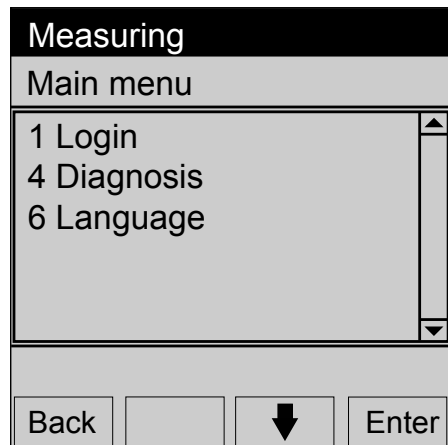

6.3 User level (Login)

Procedure

Menu: Login

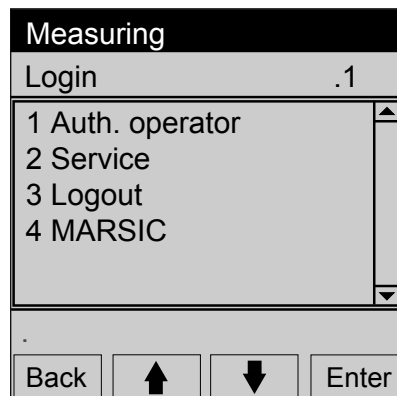

- 1 User level **AUTHORIZED OPERATOR**:
This user level is intended for trained staff
- 2 User level **Service** (for trained service)
- 3 Logout from a different User level and return to User level "Operator" (standard user level)
- 4 User level **MARSIC**:
This user level is intended for MARSIC users
Password: EMI

Figure 17: Login menu

1. Select **MARSIC**.
2. Set EMI as password (observe capital letters).
 - o Set a letter with the **EDIT** button.
 - o Confirm letter with **Select**.
 - o Terminate with **Save** after entering the last letter.
- ✓ **MARSIC OK** is displayed.



NOTE

Menu structure of user level "AUTHORIZED OPERATOR": See enclosed "BCU Operating Instructions".

6.4 Maintenance functions

6.4.1 Maintenance mode

Menu: Maintenance/Maintenance mode

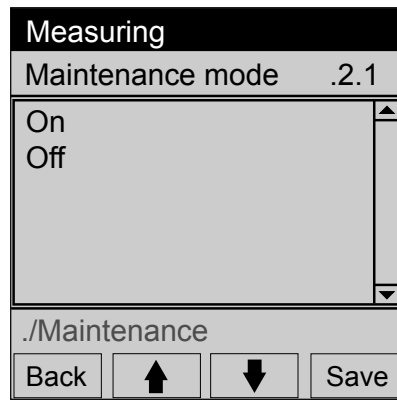

On	Maintenance flag activated
Off	Maintenance flag deactivated

Purpose

Menu function **Maintenance signal** serves to set status **C**. If this status controls a digital output of the device, this can be used to signal to an external station that the device is no longer in measuring operation because, for example, maintenance is being carried out.



NOTE

Some maintenance functions activate status **C** automatically.

6.4.2 Reset

Menu: Main menu/Maintenance/Reset

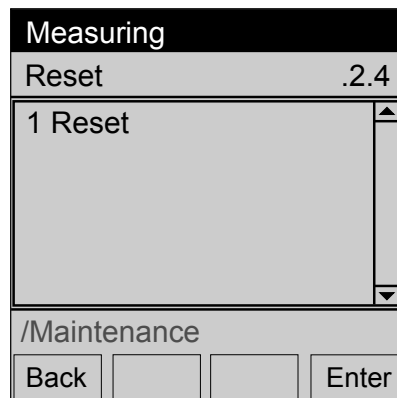

- ▶ To trigger the reset: Select **Enter**



CAUTION

Risk for connected devices/systems

The measuring functions are interrupted for a short time during the reset and the maintenance flag is activated automatically.

- ▶ Ensure this situation cannot cause any problems for connected stations.

6.5 Adjustment functions



NOTE

- Menu representation is optimized for the description and does not always correspond exactly to the actual representation on the display
- All numeric values in the menus are examples without metrological significance. The realistic values depend on the individual device in which the MARSIC200 is installed

Sequence of an adjustment/validation

Validation and adjustment sequences are identical.

The following options exist for an adjustment/validation:

- Adjustment of a single component: [see "Adjustment of single components", page 35](#)
- Validation of a single component: [see "Validation of single components", page 41](#)
- Adjustment/validation of several components (group function): [see "Adjustment/validation of several components \(group function\)", page 44](#)

6.5.1 Adjustment of single components



NOTE

- Certain settings suitable for the individual MARSIC200 and the planned application purpose are normally preset at the factory.
- The test gas settings could possibly be made so that the test gases are fed automatically via solenoid valves controlled by the MARSIC200 digital outputs.

The “adjustment of single components” can be carried out in 2 ways:

- Adjustment with preset ([see "Adjustment of single components", page 35](#)) time sequences.
After the adjustment has been started, the individual adjustment steps run independently.
- User-controlled adjustment: The adjustment steps are started individually by the user.

6.5.1.1 Prerequisites for manual adjustments

- ▶ Only use adjustment functions when the required test gas settings have been programmed correctly ([see "Configuring test gases", page 48](#)).
- ▶ Observe the physical conditions for the test gases.



NOTICE

- ▶ Always carry out the respective zero point adjustment before a reference point adjustment.

Otherwise the reference point adjustment will not be correct.



CAUTION

Possible interference when stations are connected

An adjustment procedure interrupts measuring operation.

- ▶ Before an adjustment: Inform connected locations on the impending interruption in measuring operation.

6.5.1.2 Starting the adjustment procedure

Menu: Adjustments/Adjustment

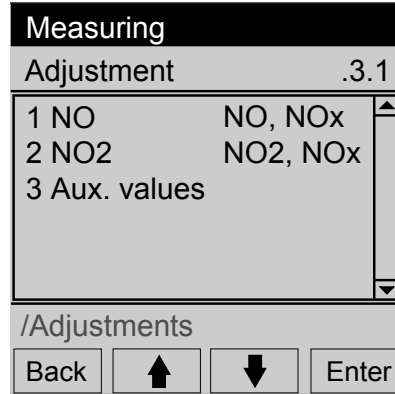

- 1 Measuring component | Internal use¹
- 2 Measuring component | Internal use
- 13 Branch to the auxiliary values²

- 1 List of measuring components where the measured value of the measuring component is used for calculation.
- 2 Explanation see "Operating Instructions BCU".

1. Select a measuring component (↓/↑, Enter).
If an auxiliary value is to be adjusted (see "Operating Instructions BCU"): Select **Aux. values** and then select the desired auxiliary value.

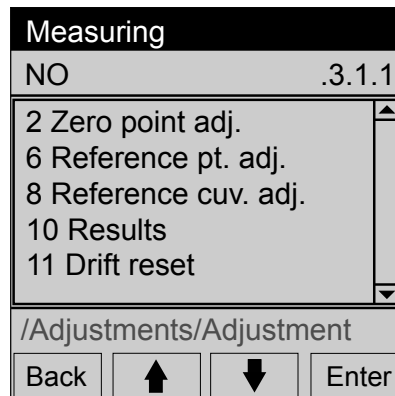

2. Select the desired adjustment function (↓/↑, Enter).

Adj. zero p. ¹	Zero point adjustment
Reference pt. adj. ¹	Reference point adjustment
Reference pt. cuv. adj. ²	Reference point adjustment with adjustment cuvette ³
Results	View the results of the last adjustment
Drift reset	Delete stored drift values (reset to 0) ⁴

- 1 Only displayed when an appropriate test gas setting exists.
- 2 Only displayed when the measuring component is measured with an Analyzer module that has an adjustment cuvette (option) and an appropriate test gas setting exists.
- 3 Use a zero gas as test gas.
- 4 Detailed information, see "Operating Instructions BCU".



NOTE

Only adjustments that can be carried out in the current operating state are shown. The respective adjustment procedure is not available for selection when at least one status message exists where the cause could make an adjustment procedure unreliable or impossible (e.g. malfunction in module, test gas malfunction).

6.5.1.3 Carrying out the adjustment procedure

- A prompt appears for the desired adjustment procedure:
 - With preset time sequences (i.e. “automatic”): [see "Adjustment with preset time sequences", page 37.](#)
 - User controlled (i.e. “step for step”): [see "User-controlled adjustment", page 38.](#)

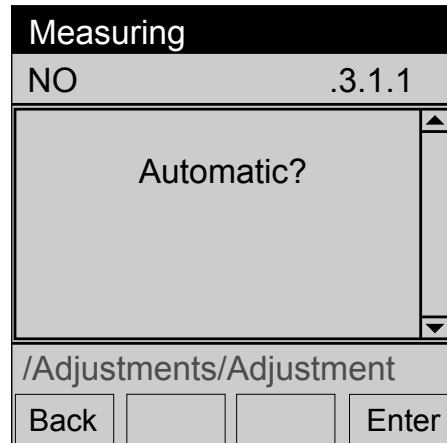

Enter Starts the automatic adjustment
 Back Starts the user-controlled adjustment

6.5.1.3.1 Adjustment with preset time sequences

Adjustment with preset (see "General settings for adjustments", page 46) time sequences.

After the adjustment has been started, the individual adjustment steps run independently.

Menu: Adjustments/Adjustment/Measuring component/Adjustment function

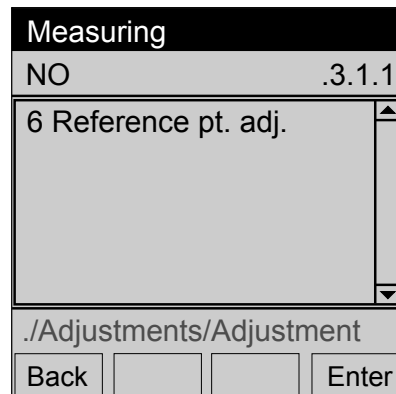

1. If the test gas is to be fed manually: Feed the suitable test gas into the sample gas inlet of the device.
2. To start the adjustment: Select **Enter**.
- ✓ If test gas feed is automated (see “Technical Information MARSIC200”): The test gas flows into the device instead of the sample gas.
- ✓ The adjustment runs.

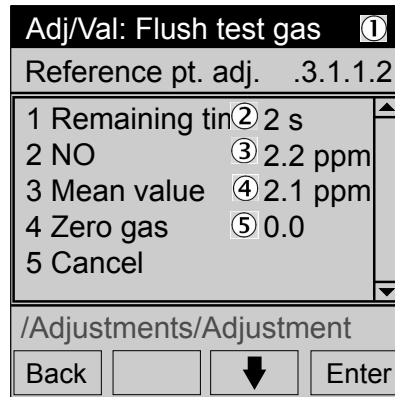

- 1 Procedure phase
- 2 Remaining time of the procedure phase
- 3 Measuring component | Current measured value (actual value)
- 4 Mean value of measured values (during MEASURE)
- 5 Name of the test gas setting | Setpoint

Table 3: Procedure phases for adjustment and validation

Procedure phase		Text in the status line
1	Test gas is fed.	Flush test gas
2	The measured value of the test gas is determined (actual value).	Measuring
3	The results are calculated and stored. – For adjustment: The adjustment is performed.	Calculate
4	The sample gas is fed again.	Flush sample gas

- ▶ To interrupt the procedure: Select **Cancel** (↓/↑, Enter).
- 3. Wait until **Show results?** is displayed.
- 4. To view the results (as information): Select **Enter**. Otherwise: Select **Back**.

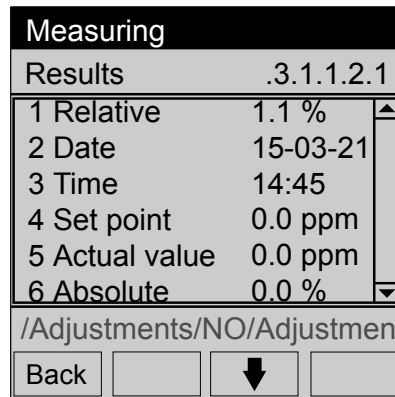

- 1 Drift between this adjustment and the previous one¹
- 2 Date of adjustment (completion) [year-month-day]
- 3 Time of adjustment (completion) [00:00 ... 23::59]
- 4 Setpoint of test gas assigned
- 5 Mean value of measured actual values
- 6 Absolute drift²

¹ Information on the calculation method, see "Operating Instructions BCU"
² Explanation, see "Operating Instructions BCU"

- 5. The adjustment is terminated.

6.5.1.3.2 User-controlled adjustment

User-controlled adjustment: The adjustment steps are started individually by the user. This adjustment needs the individual steps to be started after each other.

Menu: **Adjustments/Adjustment/Measuring component/Adjustment function**

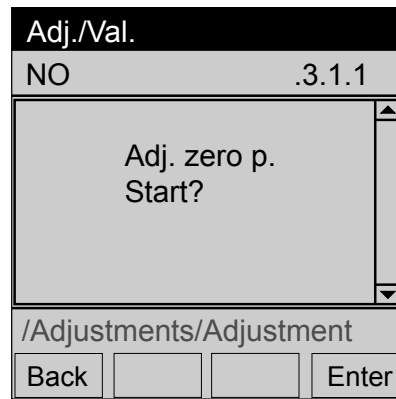

Enter Starting the adjustment

1. If the test gas is to be fed manually: Feed the suitable test gas into the sample gas inlet of the device.
2. To start the adjustment procedure: Select **Enter**.
- ✓ If test gas feed is automated (see “Technical Information MARSIC200”): The test gas flows into the device instead of the sample gas.
- ✓ The adjustment procedure runs.

The adjustment is carried out in single steps (flush test gas - measurement - calculate - flush sample gas - measuring operation).

Table 4: Procedure phases for adjustment procedures and validation measurements

Procedure phase		Text in the status line
1	Test gas is fed.	Flush test gas
2	The measured value of the test gas is determined (actual value).	Measuring
3	The results are calculated and stored. For adjustment procedures: The adjustment is performed.	Calculate
4	The sample gas is fed again.	Flush sample gas

Each step must be started with **Enter**.

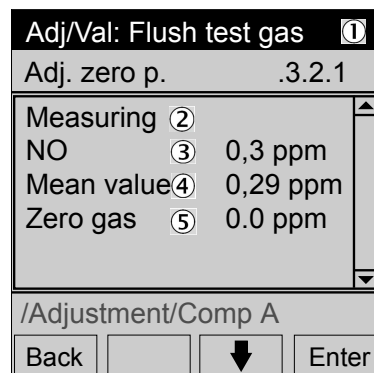

- 1 Procedure phase
- 2 Start the next phase “Measure” with “Enter”
- 3 Measuring component | Current measured value (actual value)
- 4 Mean value of measured values (during MEASURE)
- 5 Name of the test gas setting | Setpoint

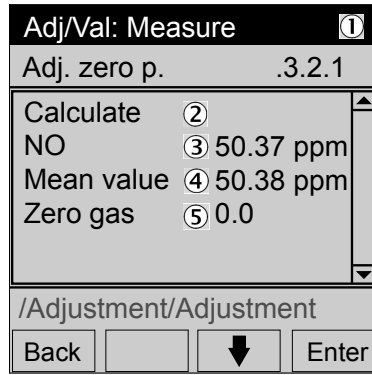

- 1 Procedure phase
- 2 Start the next phase “Calculate” with “Enter”
- 3 Measuring component | Current measured value (actual value)
- 4 The calculated mean value is saved (adjustment)
- 5 Name of the test gas setting | Setpoint

► To interrupt the procedure: Select **Cancel** (↓/↑, Enter).

3. Wait until **Show results?** is displayed.
4. To view the results (as information): Select **Enter**. Otherwise: Select **Back**.

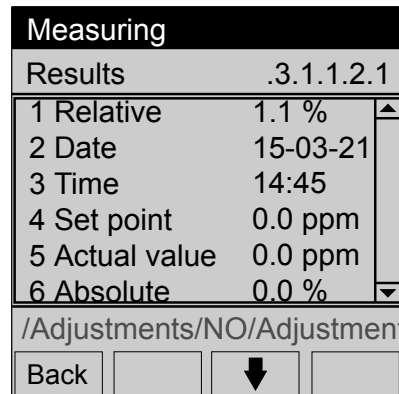

- 1 Drift between this adjustment and the previous one¹
- 2 Date of adjustment (completion) [year-month-day]
- 3 Time of adjustment (completion) [00:00 ... 23::59]
- 4 Setpoint of test gas assigned
- 5 Mean value of measured actual values
- 6 Absolute drift²

¹ Information on the calculation method, see “Operating Instructions BCU”
² Explanation, see “Operating Instructions BCU”

5. The adjustment procedure is terminated.

6.5.1.4 Viewing adjustment results

Menu: **Adjustments/Adjustment/Measuring component/Results/Zero point or /Ref. point**

This menu shows the respective result of the last adjustment for the selected measuring component.

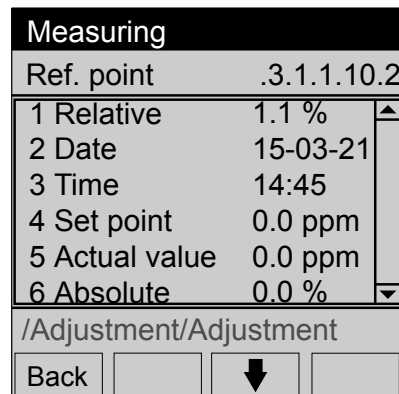

- 1 Drift between this adjustment and the previous one
- 2 Date of adjustment (completion) [year-month-day]
- 3 Time of adjustment (completion) [00:00 ... 23::59]
- 4 Setpoint of test gas assigned
When using a calibration cuvette: Concentration of the calibration cuvette
- 5 Mean value of measured actual values
- 6 Absolute drift

6.5.2 Validation of single components

Purpose

A validation is a measuring procedure with a test gas. A validation runs the same as an adjustment procedure; the measuring results are stored the same as in an adjustment procedure. The device parameters are however not changed.

Corresponds to: [see "Adjustment of single components", page 35](#).



NOTE

- Validations are only available for measuring components, not for auxiliary values or virtual measuring components.
- The test gas settings could possibly be made so that the test gases are fed automatically via solenoid valves controlled by the MARSIC200 digital outputs.
- Validations can be automated in the same manner as adjustments ([see "Setting an automatic adjustment start", page 44](#)).

Procedure

Menu: Adjustments/Validation

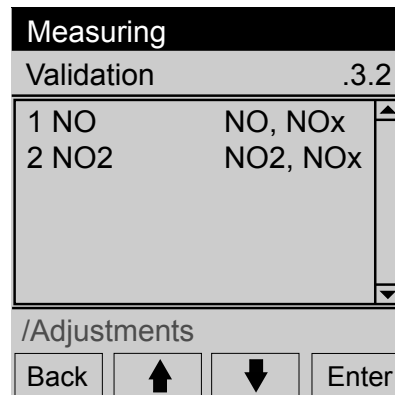

- 1 Measuring component | Internal use¹
- 2 Measuring component | Internal use

¹ List of measuring components where the measured value of the measuring component is used for calculation.

1. Select a measuring component (↓/↑, Enter).
2. Select the desired validation function (↓/↑, Enter).

Zero point val. ¹	Validation at zero point
Reference pt. val. ¹	Validation at reference point
Reference pt. cuv. val. ²	Validation with the adjustment cuvette ³
Results	View the results of the last validation

¹ Only displayed when an appropriate test gas setting exists.

² Only displayed when the measuring component is measured with an Analyzer module that has an adjustment cuvette (option) and an appropriate test gas setting exists.

³ Use a zero gas as test gas.



NOTE

Only validations that can be carried out correctly in the current operating state are shown. The respective validation is not available for selection when at least one status message exists where the cause could make a validation unreliable or impossible (e.g. malfunction in Analyzer module, test gas malfunction).

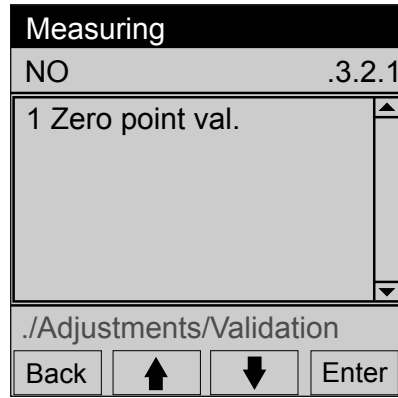

3. If the test gas is to be fed manually: Feed the assigned test gas into the sample gas inlet of the device.
4. To start the validation: Select **Enter**.



CAUTION

Possible interference when stations are connected

A validation interrupts measuring operation.

- ▶ Before a validation: Inform connected locations on the impending interruption in measuring operation.

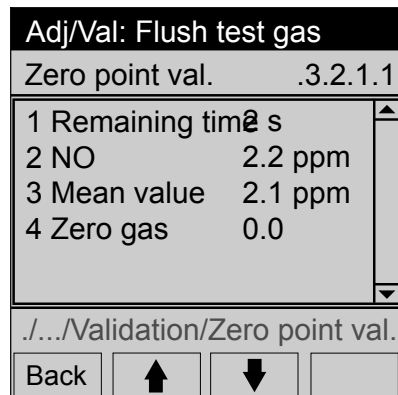

- 1 Remaining time of the procedure phase
- 2 Measuring component | Current measured value (actual value)
- 3 Mean value of measured values (during MEASURE)
- 4 Name of the test gas setting | Setpoint
- 1

1 Not shown: 5 Cancel

- ▶ To interrupt the procedure: Select **Cancel** (↓/↑, **Enter**).
5. Wait until **Show results?** is displayed.
 6. To view the result (as information): Select **Enter**. Otherwise: Select **Back**.

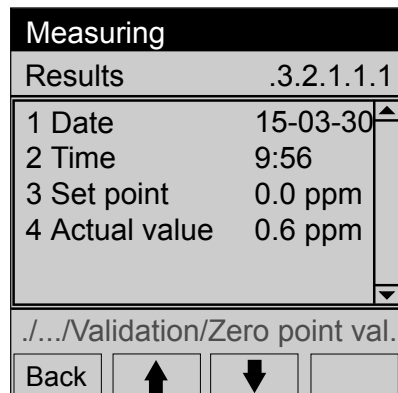

- 1 Date of validation (completion) [year-month-day]
- 2 Time of validation (completion) [00:00 ... 23::59]
- 3 Setpoint of test gas assigned
- 4 Mean value of measured actual values

7. The validation is terminated.

6.5.2.1 Viewing validation results

Menu: Adjustments/Validation/Measuring component/Results/Zero point or /Ref. point

Measuring	
Zero point	.3.2.1.10.1
2 Date	15-03-21
3 Time	14:45
4 Set point	0.0 ppm
5 Actual value	0.0 ppm

/Adjustment/Adjustment

Back

- 2 Date of validation (completion) [year-month-day]
- 3 Time of validation (completion) [00:00 ... 23::59]
- 4 Setpoint of test gas assigned
- 5 Mean value of measured actual values



NOTE

This information is also available in menu **Validation results** (see "[Viewing validation results](#)", page 60).

6.5.3 Adjustment/validation of several components (group function)

The following options can be started:

- Manual start: see "Adjustment/validation of several components (group function)", page 44.
- Automatic time-controlled start: see "Setting an automatic adjustment start", page 44.
- Triggered via:
 - Digital signals, see "Technical Information MARSIC200"
 - Modbus (see "BCU Technical Information" chapter I/O Configuration)

6.5.3.1 Starting adjustment manually (Group function)

Menu: Adjustments/Group functions

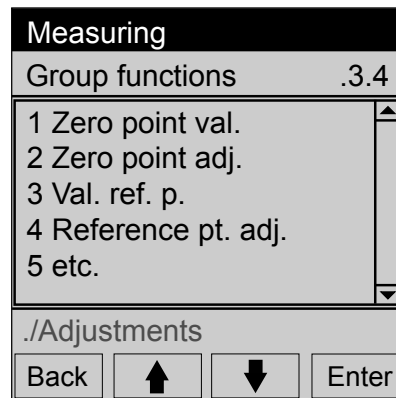

- 1 Zero point validation (check)
- 2 Zero point adjustment (check and set)
- 3 Reference point validation
- 4 Reference point adjustment
- 5 Reference point validation with cuvette
- 6 Reference point adjustment with cuvette
- 9 Cancel

Figure 18: Menu *Group functions* (example)



NOTE

- Adjustment procedures suitable for the individual device are normally already specified at the factory.
- Adjustment procedures currently "active" cannot be started manually.
- Only adjustments that can be carried out in the current operating state are shown for selection. The respective adjustment procedures are not available for selection when a status message exists where the cause could make an adjustment procedure unreliable or impossible.

1. Select the desired adjustment procedure (↓/↑, Enter).
 - ✓ **Start adjustment procedure?** is displayed.
2. To start the automatic process: Select **Enter**.
To abort the automatic process: Select **Cancel** (↓/↑, Set).
- ✓ The **yellow** LED goes on and **Active** is displayed.
3. Wait until the adjustment procedure has completed: The **yellow** LED goes off again.
 - When an error has occurred, the **yellow** LED remains on or the **red** LED comes on. The status bar displays **See Logbook**.

6.5.4 Setting an automatic adjustment start

Menu: Adjustments/Settings/Automatic

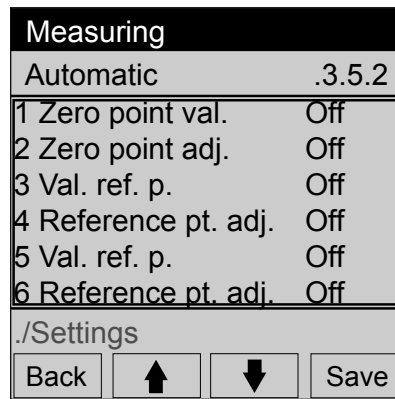

1, 2, ... Name of the automatic adjustment procedure
| Activation status

Menu: Adjustments/Settings/Automatic/Adjustment procedure

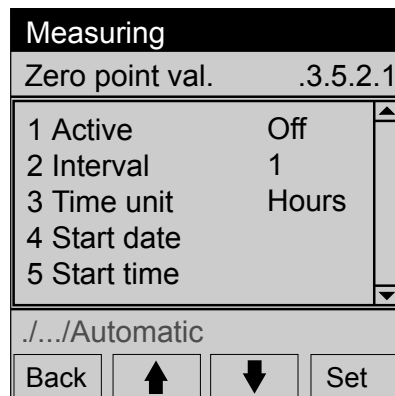

1 Function | Current setting
2, 3 Interval and time unit. Adjustment is carried out every hour in the example.
4, 5 Start time for the first adjustment

6.5.4.1 Activating/deactivating adjustment

Menu: Adjustments/Settings/Automatic/Adjustment procedure/Active

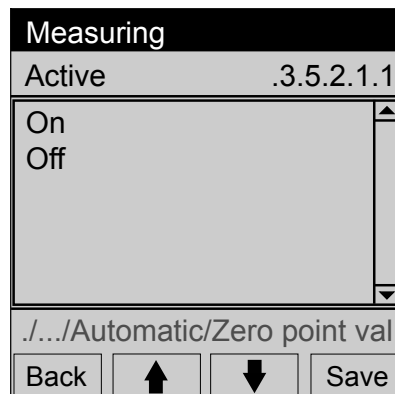

On Automatic procedure activated
Off Automatic procedure deactivated

► Select the desired state (↓/↑, Save).

6.5.4.2 Setting the interval for the automatic adjustment

Menu: Adjustments/Settings/Automatic/Adjustment procedure/Interval

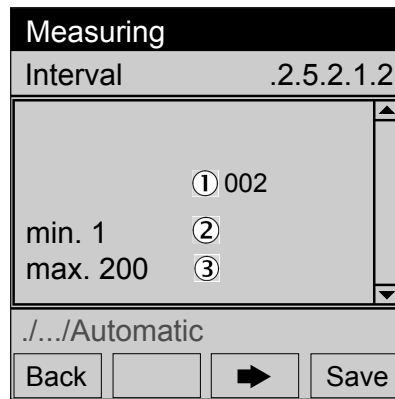

- 1 Numeric value for the interval
- 2 Smallest value allowed
- 3 Largest value allowed

► Set the desired value.

Changing the time unit (when necessary):

Menu: Adjustments/Settings/Automatic/Adjustment procedure/Time unit

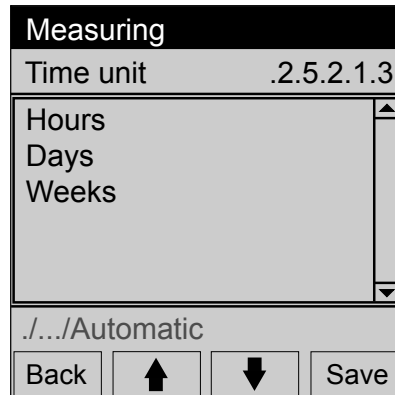

► Set the appropriate time unit (↓/↑, Save).

6.5.4.3 Setting the start time for the next adjustment

Menu: Adjustments/Settings/Automatic/Adjustment procedure/Start date

- 1. Set the desired date.
- 2. Back → Select start time.

Menu: Adjustments/Settings/Automatic/Adjustment procedure/Start time

- 3. Set the desired time.

6.5.5 General settings for adjustments

6.5.5.1 Setting the measuring time for adjustments

Menu: Adjustments/Settings Adj./Meas. duration

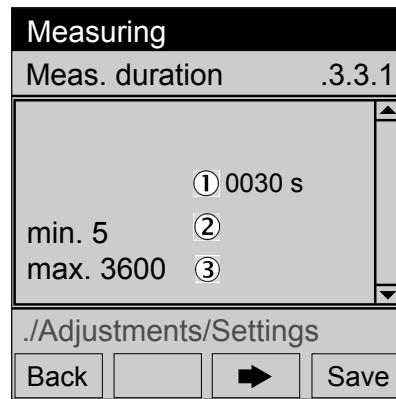

- 1 Measuring time [seconds]
- 2 Minimum value
- 3 Maximum value

- ▶ Set the appropriate value.

Purpose

The measuring time specifies how long the measured values of a fed test gas are determined. It starts each time after a test gas flush time (see "Setting the sample gas flush time for adjustments", page 47). The mean value of these measured values is:

- For adjustments: The actual value for the adjustment.
- For validation measurements: The measured value of the validation measurement.

Criteria for the setting

- Adapting to the damping: The measuring time must be at least 150 ... 200 % of the damping time constant set (see "Operating Instructions BCU").
- Adapting to the measuring behaviour: Select the length of the measuring time so that average value creation completely compensates any "noise" present in the measured values as well as any fluctuations in measured values.



CAUTION

Risk of incorrect adjustment

Adjustments will be inexact or incorrect when the measuring time is set too short.

- ▶ Preferably set the measuring time too long rather than too short.



CAUTION

Risk of incorrect adjustment

The measuring time must be at least 150% of the damping time constant set.

- ▶ Check the damping setting (see "Operating Instructions BCU").



NOTE

- The longer the measuring time, the more exact the adjustment.
- The measuring time also affects manual adjustments (see "Operating Instructions BCU").

6.5.5.2 Setting the sample gas flush time for adjustments

Menu: Adjustments/Settings Adj./Sample gas flush time

Measuring	
Sample gas flush time.3.3.2	
① 0125 s	
min. 5	②
max. 3600	③
./.../Settings/Settings Adj.	
Back	Save

- 1 Sample gas flush time [seconds]
- 2 Minimum value
- 3 Maximum value

- ▶ Set the appropriate value.

Purpose

The sample gas flush time is a wait time that runs down after each adjustment or validation before the status **Adjustment** or **Validation** is reset. The sample gas flush time belongs to the process flow of the adjustment/validation procedure. This considers the response time after switching from the last test gas to sample gas. The setting is valid for all adjustments and validations.



CAUTION

Possible interference when systems are connected

If the sample gas flush time is set too short, MARSIC200 signals the normal operating state before the measured values correspond to the actual concentration. This could cause control faults when the measured values control the connected system.

- ▶ Preferably set the sample gas flush time too long rather than too short.

Criteria for the setting

When the flush time ends, the Analyzer module must be filled with the new gas and MARSIC200 should display the “final” measured values of the gas. A suitable flush time more or less corresponds to the MARSIC200 reaction time (lag time + 100% time).

Measuring the response time:

- ▶ Check for each measuring component how long it takes for the displayed measured value to remain constant after switching to a different gas.
- ▶ Use the longest reaction time as flush time.

On the other hand, flush times should not be longer than necessary because the normal measuring function is interrupted during an adjustment or validation procedure.

6.5.6 Configuring test gases

6.5.6.1 Principle for test gas settings

The test gas settings serve as basis for adjustments. A test gas setting includes the set point (concentration) and process parameters for the adjustment procedure for a real test gas. With which adjustment procedures a test gas setting can be used is also specified.

A real test gas can be used in several test gas settings. This allows configuring one certain real test gas with different tests gas settings for different adjustments.

All test gas settings can also be used for validation measurements. 12 different test gas settings can be programmed.



NOTE

- Suitable test gas settings are normally preprogrammed at the factory.
- If you want to program new test gas settings: see "Configuring test gases", page 48
- Recommendation: Only use each test gas setting for a certain adjustment or validation.

6.5.6.2 Menu Test gase

Menu: Adjustments/Settings/Test gases

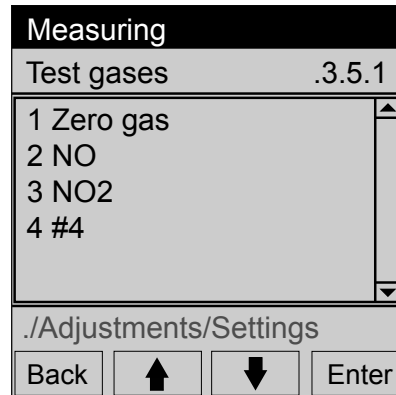

- 1 Name of the test gas setting
- 2 Name of the test gas setting
- 3 Name of the test gas setting
- 4 Unused¹

¹ Or a test gas setting for which a name has not been programmed.

To change or check an existing test gas setting:

1. Select the desired test gas setting (↓/↑, Enter)
To program a new test gas setting: Select an unused location

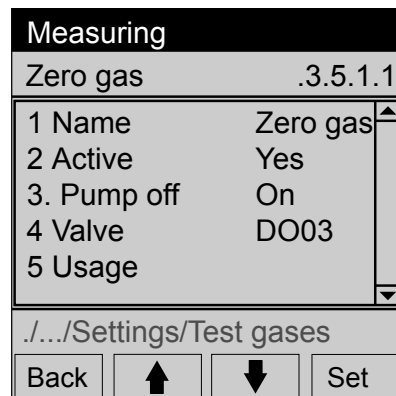

- 1 Name of this test gas setting¹
- 2 Yes = this test gas can be selected for adjustments/validations
- 3 State of the sample gas pump when using the test gas
- 4 Digital output to be activated when the test gas is used (to control a solenoid valve)
- 5 Metrological settings of the test gas

¹ If a name has not been programmed, the number of the measuring point is displayed as "#N" in other menus instead of the name (N = number of the measuring point).

2. Select the desired setting (↓/↑, Enter/Set)
3. Create the desired state (see "Configuring test gases", page 48)

6.5.6.3 Programming a test gas setting - Part 1: Integration

These settings define whether, and under which name, a test gas setting appears in other functions and which control functions it triggers.

6.5.6.3.1 Defining the name of the test gas setting

Menu: **Adjustments/Settings/Test gases/Test gas setting/Name**

- ▶ Set the desired name.

Purpose

The name of a test gas setting is freely selectable (maximum 16 characters). Examples: "Nitrogen", "Zero gas", "NO test gas".

6.5.6.3.2 Setting the availability of the test gas setting

Menu: **Adjustments/Settings/Test gases/Test gas setting/Active**

Yes	This test gas setting can be used
No	This test gas setting can not be used

- ▶ Select the desired state (↓/↑, Save).

Purpose

This setting serves to deactivate a test gas setting completely without deleting it.

6.5.6.3.3 Setting the pump mode

Menu: **Adjustments/Settings/Test gases/Test gas setting/Pump off**

On	The sample gas pump is switched off automatically when the test gas is used
Off	The sample gas pump remains switched on when the test gas is used

- ▶ Select the desired state (↓/↑, Save).

Purpose

The sample gas pump can be switched off automatically when this test gas setting is active - i.e. when the respective test gas flows into the device.

6.5.6.3.4 Selecting the valve control

Menu: **Adjustments/Settings/Test gases/Test gas setting/Valve**

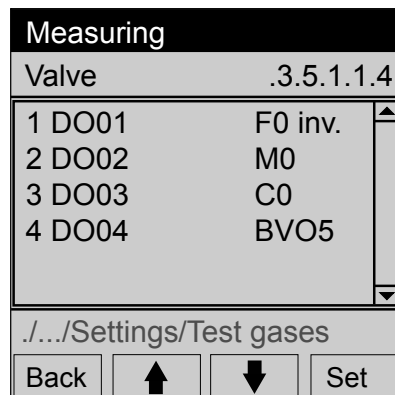

- 1 Digital output | Internal control signal | Switching logic

- ▶ Select the desired digital output (↓/↑, Set).
- ▶ Select the electronic switching logic in the next menu (↓/↑, Save).



NOTE

- Explanation of the electronic switching logic, see “Technical Information BCU”.

Purpose

The setting defines which dialog output is activated when this test gas setting is active during an adjustment procedure or a validation measurement. This allows automatic control of test gas feed.

6.5.6.4 Programming a test gas setting - Part 2: Usage

These settings define:

- For which measuring components the test gas can be used.
- For which adjustment procedures and validation measurements.
- Which physical parameters are used for the respective selection.

6.5.6.4.1 Usage menu for a test gas

Menu: **Adjustments/Settings/Test gases/Test gas setting/Usage**

Measuring	
Usage	.3.5.1.1.5
1 NO	0.0 Yes
2 NO2	0.0 Yes
3	0.0 No
4	0.0 No

./.../Test gases/Zero gas

Back ↑ ↓ Enter

- 1 Selected measuring component | Setpoint (Concentration) | Usage
- 2 Selected measuring component | Setpoint (Concentration) | Usage
- 3 Unused
- 4 Unused



NOTE

- The list shows all measuring components assigned up until now.
- The measuring component does not have to be deleted from the list when the test gas is not to be used any more for one of these measuring components (see "[Setting the availability of the test gas setting](#)", page 50).

- ▶ To change the settings for an existing measuring component: Select the desired measuring component (↓/↑, Enter).
- ▶ To add a measuring component: Select an unused location.

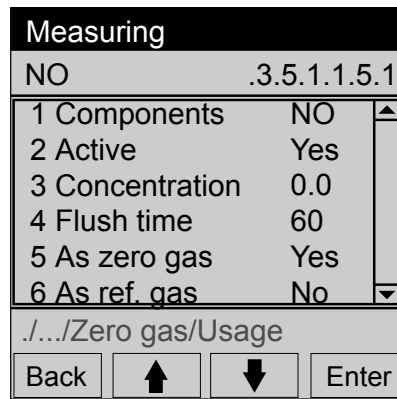

- 1 Selected measuring component
- 2 Yes: This test gas setting is available in other functions¹
- 3 Setpoint (concentration) of test gas
- 4 Wait time between activating the test gas and start of the measurements
- 5 Yes/no: This test gas can/cannot be used for zero point adjustments ²
- 6 Yes/no: This test gas can/cannot be used for span point adjustments ²

¹ No prevents use in adjustments and validations. This can be used, for example, when the real test gas is not available temporarily or should not be used.
² Also applicable for validation measurements.

6.5.6.4.2 Assigning a measuring component

Menu: **Adjustments/Settings/Test gases/Test gas setting/Usage/Measuring component/Component**

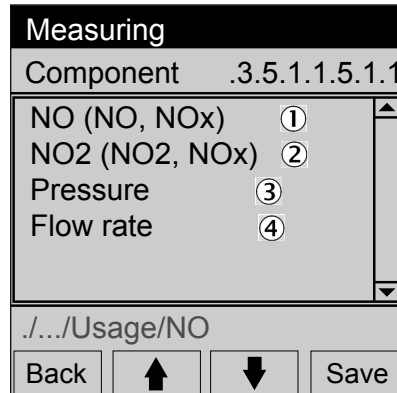

- 1, 2 Real measuring component | Real + virtual measuring components¹
- 3, 4 Further variables

¹ The specifications on the right show, as information, the measuring components for which the real measuring component is used. Nothing is displayed there when this is identical with the real measuring component. – Explanation of virtual measuring components, see “Operating Instructions BCU”.

► Select a measuring component (↓/↑, Save).

Purpose

This setting assigns a measuring component to the respective location in the **Usage** list of the test gas setting.

6.5.6.4.3 Setting the availability for the measuring component

Menu: **Adjustments/Settings/Test gases/Test gas setting/Usage/Measuring component/Active**

Yes	The test gas is available for adjustment procedures for this measuring component ¹
No	The test gas cannot be selected for adjustment procedures for this measuring component ¹

¹ Also applicable for validation measurements.

► Select the desired state (↓/↑, Save).

Purpose

This setting serves deactivating usage of the test gas for the respective measuring component without deleting the settings for this measuring component.

6.5.6.4.4 Setting the set point for a measuring component

Menu: **Adjustments/Settings/Test gases/Test gas setting/Usage/Measuring component/Concentration**

- ▶ Set the desired setpoint value (in the physical unit of the measured value involved).

Purpose

This setting determines the set point of the test gas for the adjustments during which these test gas settings are used.

Criteria for the setting

- The setpoint value is generally the actual concentration of the measuring component in the test gas used.
- However, it is also possible to set a setpoint value that deviates from the actual concentration - e.g., to compensate a cross-sensitivity effect.



NOTE

It is possible to set different set point values for various measuring components in the same test gas setting. This can be useful, for example, when a test gas mixture containing several measuring components is used.

6.5.6.4.5 Setting the flush time for adjustments

Menu: **Adjustments/Settings/Test gases/Test gas setting/Usage/Measuring component/Flush time**

- ▶ Set the desired value.

Purpose

The flush time is the wait time between switching to the test gas and measuring time start. It can be set individually in each test gas setting for each measuring component.

Criteria for the setting



CAUTION

Risk of incorrect adjustment

The adjustment will be incorrect when the flush time is set too short.

- ▶ Preferably set the flush time too long rather than too short.

6.5.6.4.6 Setting the usability as zero gas

Menu: **Adjustments/Settings/Test gases/Test gas setting/Usage/Measuring component/as zero gas**

These settings determine during which adjustments and validations the respective test gas is available as zero gas.

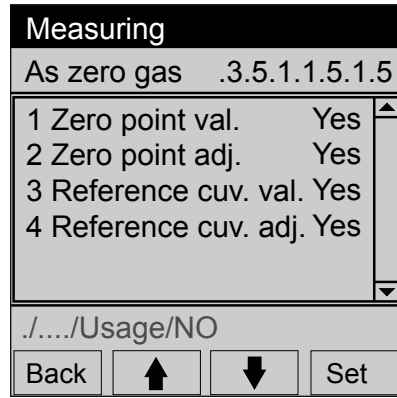

- 1 Zero point validation
- 2 Zero point adjustment
- 3 Reference point validation with adjustment cuvette¹
- 4 Reference point adjustment with adjustment cuvette¹

¹ Only available when the respective measuring component is measured with an Analyzer module that has an adjustment cuvette (option)

1. Select an adjustment or validation (↓/↑, Set).
2. Select the desired state (↓/↑, Save).

Yes	The test gas is available for the selected adjustment/validation procedure for the respective measuring component
No	The test gas is not available for the selected adjustment/validation procedure for the respective measuring component



NOTE

The test gas must be used as zero gas during a reference point adjustment with an adjustment cuvette (option on some Analyzer modules).

6.5.6.4.7

Setting the usability as span gas

Menu: Adjustments/Settings/Test gases/Test gas setting/Usage/Measuring component/as Ref. gas

These settings determine during which adjustments and validations the respective test gas is available as span gas.

- ▶ Set the desired states in the same manner as for zero gas (see "Setting the usability as zero gas", page 53).

6.6 Diagnosis functions

6.6.1 Diagnosis functions overview

Menu: Diagnosis

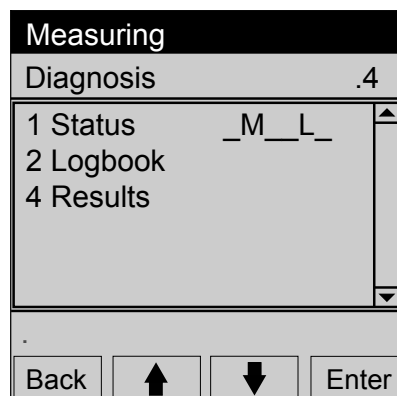

- 1 see "Checking the status", page 56
- 2 see "Logbook messages", page 109
- 3 see "Adjustment/validations results", page 59

6.6.2 Status message categories

Flag	Significance	
F	Failure	Failure ¹
M	Maintenance request	Maintenance request ¹
C	Check	Function check ² (measuring function is interrupted)/ "Maintenance" state ¹
U	Uncertain	Uncertain state or uncertain measured value ¹
L	Limit	Limit value overflown or underflown
T	Timeout	Internal measurement signal failure
E	Extended	Extended information

¹ Corresponds to NAMUR specification.

² Example: Adjustment.

6.6.3 Checking the status

6.6.3.1 Menu "Status"

Menu: Diagnosis/Status

This menu shows the function groups with their group status.

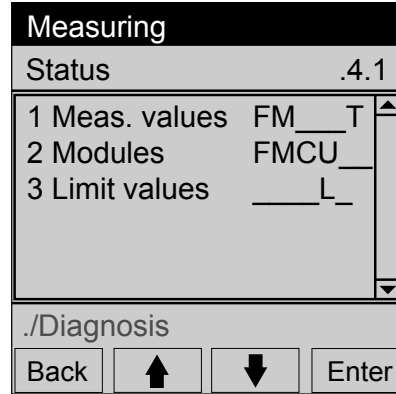

1, 2 ... Function group | Function group status¹

¹ Key to symbols (see "Status message categories", page 55)

- ▶ To check a single status: Select a function group.

6.6.3.2 Measured value status

Menu: Diagnose/Status/Meas. values

This menu shows the status for single measured values.

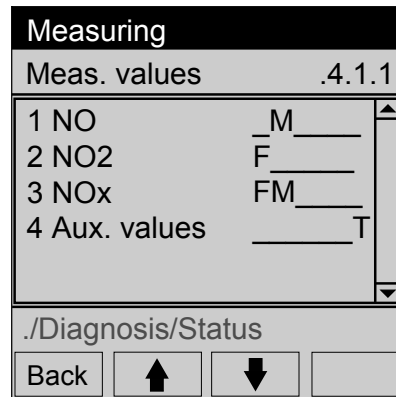

1 Measuring component | Status¹
 2 Measuring component | Status
 3 Measuring component | Status
 4 Branch to status of auxiliary values | Group status²

¹ Key to symbols (see "Status message categories", page 55)

² Group status of all auxiliary values

6.6.3.3 Module status

Menu: Diagnosis/Status/Modules

The menus under **Modules** show the status of single analyzer modules.

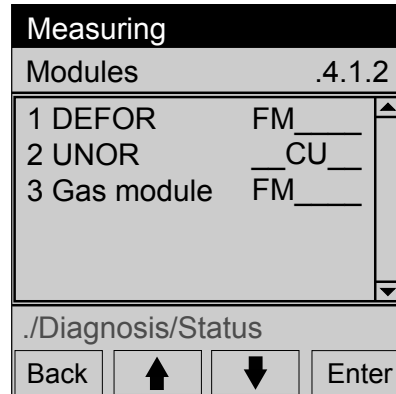

- 1 DEFOR status¹
- 2 FINOR status
- 3 Gas module status

¹ Key to symbols (see "Status message categories", page 55)

► To view detailed information: Select a module.

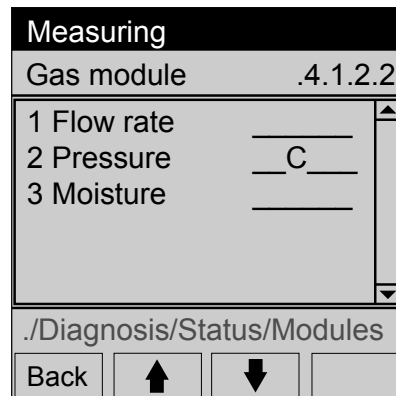

- 1 - 3 Measuring component | Status of measurement¹

¹ Key to symbols (see "Status message categories", page 55)

6.6.3.4 Limit values status

Menu: Diagnosis/Status/Limit values

This menu shows which measured values are beyond a set limit value. The limit values are displayed when a measuring component is selected.

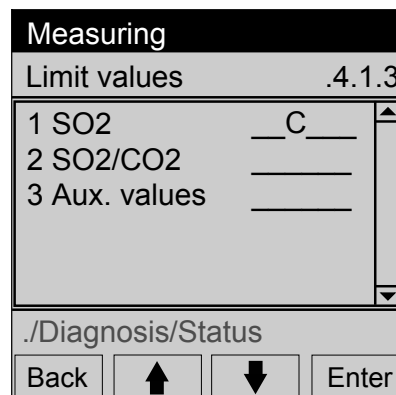

- 1 Measuring component | Status¹
- 2 Ratio
- 3 Branch to the auxiliary values | Group status²

¹ L = the current measured value is beyond a limit value.

² Group status of all auxiliary values.

► To view the limit values: Select a measuring component.

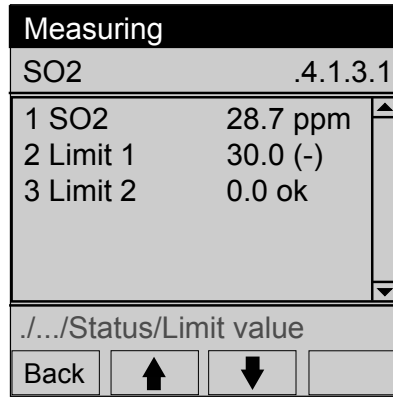

- 1 Measuring component | Current measured value
- 2 Limit value 1 | Limit value status
- 3 Limit value 2 | Limit value status

Limit value status	Significance
OK	The current measured value is within the programmed limit values
(-)	The current value is lower than the limit value. ¹
(+)	The current value is higher than the limit value. ²

¹ Only displayed when the limit value is set to **Message when underflown**.
² Only displayed when the limit value is set to **Message when overflown**.



NOTE

Setting limit values: see "Operating Instructions BCU" (user level: Authorized operator).

6.6.4 Displaying the logbooks

Menu: Diagnosis/Logbooks

One logbook contains the respective latest internal functions and status messages.

- For the BCU: Maximum 50 messages.
- For other modules: Maximum 30 messages.

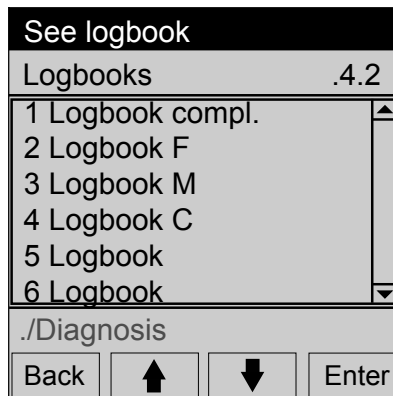

- 1 Logbook with all messages
- 2, etc. Logbook for a certain category¹

¹ Explanation (see "Status message categories", page 55)

1. Select a logbook.

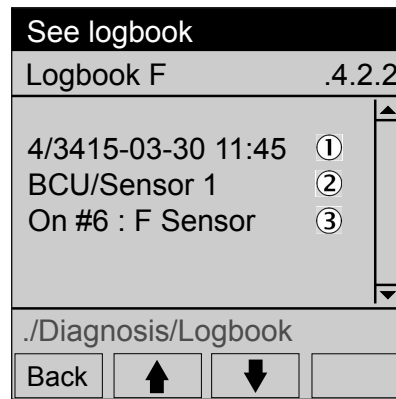

- 1 Sequential No./total number of messages | Date+time of last status change for this message (on/off)
- 2 Triggering module/detected cause¹
- 3 Status of this message (last status change)
 - Number of activations of this message
 - 2
 - Category of status message⁴
 - Message³

- 1 When detected
- 2 Since last logbook deletion (Service function)
- 3 Explanation (see "Logbook messages", page 109)
- 4 Explanation: see "Status message categories", page 55

2. To view the other logbook entries: Select ↓/↑.



NOTE

Sequence of logbook entries:

- First the messages currently existing (cause still present) in the activation sequence, newest message first.
- Then messages already deactivated (cause no longer present), newest message again first.



NOTE

Explanation on messages: see "Logbook messages", page 109.

6.6.5 Adjustment/validations results

6.6.5.1 Viewing adjustment results

Menu: Diagnosis/Results/Adjustment results

These menus show the data from the respective last adjustment.

- 1. Select a measuring component. To select an auxiliary value: Select **Aux. values** and then select the desired auxiliary value.
- 2. Select **Zero** or **Ref. point**.

Measuring	
Ref. point	.4.4.1.1.2
1 Relative	0.0 %
2 Date	15-03-27
3 Time	09:14
4 Setpoint	2000 ppm
5 Actual value	1998 ppm
6 Absolute	7.2 %
./.../Adjustment results/NO	
Back	↑ ↓

- 1 Drift between this adjustment and the previous one
- 2 Date of adjustment (completion) [year-month-day]
- 3 Time of adjustment [00:00:00 ... 23:59:59]
- 4 Setpoint of test gas assigned
- 5 Average of measured actual values (adjustment result)
- 6 Absolute drift
An “absolute” drift represents the total change of a drift value across several adjustments – therefore it is not the difference between the last two adjustments. Absolute drifts relate to the measured values displayed (including linearization, drift compensation etc.). The zero point drifts relate to the physical measurement span of the respective analyzer module and the reference drifts relate to the setpoint of the test gas during the adjustment.

6.6.5.2 Viewing validation results

Menu: Diagnosis/Results/Validation results

These menus show the data from the respective last validation.

1. Select a measuring component (**Enter**).
2. Select **Zero** or **Ref. point**.
3. The following menu is displayed:

Measuring	
Zero point	.4.4.2.1.1
2 Date	15-03-21
3 Time	14:45
4 Setpoint	0.0 ppm
5 Actual	0.0 ppm
./.../Validation results/NO	
Back	↓

- 2 Date of validation (completion) [year-month-day]
- 3 Time of validation (completion) [00:00 ... 23:59]
- 4 Setpoint of test gas assigned
- 5 Mean value of measured actual values (validation result)



NOTE

- User level **Authorized Operator** can also view this information in menu Results.

6.7 Configuring

6.7.1 Setting the internal clock

6.7.1.1 Setting the date

Menu: Parameter/Date - Time/Date

- ▶ Setting the date.

6.7.1.2 Setting the time

Menu: Parameter/Date - Time/Time

- ▶ Setting the time.

6.7.2 Configuring the test gases

Menu: Parameter/Special/Custom FCT.

This menu serves to set the test gas concentrations.

1. Select **10 Special fct.**
2. Select **2 Customer fct.**
3. A menu to select the desired test gas is displayed:

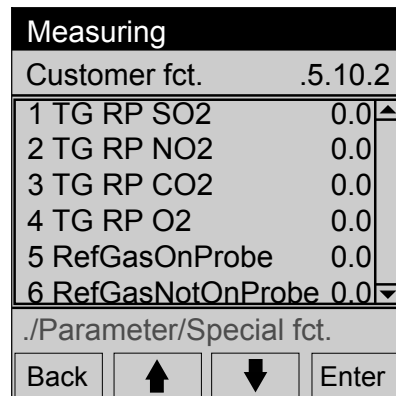

TG = Test gas
 RP, conc. = Reference point (test gas concentration)
 "0.0" is shown as concentration.
 Select the required test gas to set the test gas concentration

Figure 19: Menu Parameter/Special fct./Customer fct.



NOTICE

The shown value 0.0 is an "Default" value and **not** the set test gas concentration

4. A menu for setting and saving the test gas concentration is displayed:

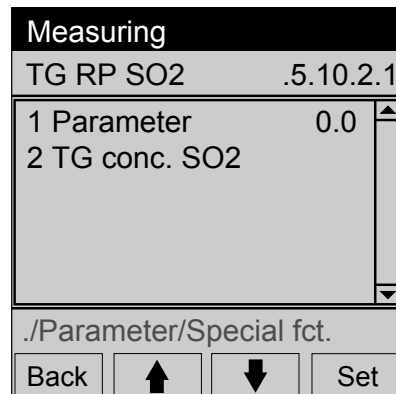

- 1 Set the test gas concentration (see below) ...
 - 2 ... and then transfer it to the analyzer
- Successful** is displayed and the concentration is shown again as "0.0"

Figure 20: Menu Parameter/Special fct./Customer fct.

- ✓ After successful input, concentration "0.0" is shown again.

Menu for setting the test gas concentration:

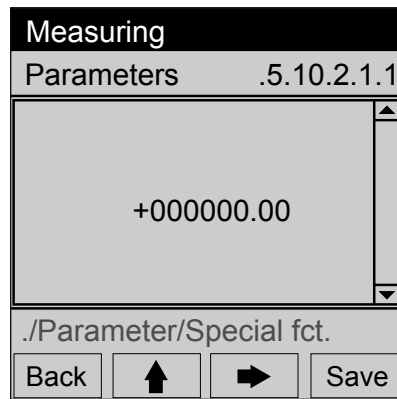

6.8 Measuring point switchover (measuring point automatic)

Measuring point switchover can be configured via the BCU or very easily via operating software SOPAS ET (SOPAS ET, see “Technical Information MARSIC200”).

Measuring point switchover via control unit

1. Set the number of available measuring points:
 - ▷ Login as “Service” on the operator panel in menu Login.
 - ▷ Call up menu Parameter/Special fct./Meas.point autom./Meas.point (MPi).

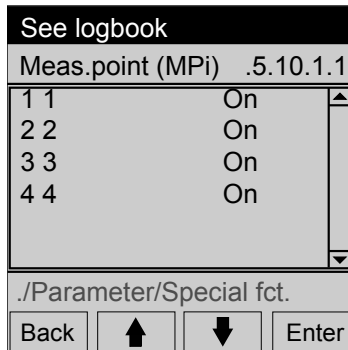

- ▷ Activate the desired measuring point (switch to “On”).

6.9 Configuring measuring point switchover



NOTE

Functional principle, prerequisites and consequences of measuring point switchover: See “Operating Instructions BCU” Chapter “Automatic measuring point switchover”.

A measuring point is shown as follows on the display:

- NO Mx = component NO on measuring point x
or for long texts
- #x = Indicator for measuring point x

6.9.1 Configuring a measuring point

Menu: Parameter/Special fct./Meas.point autom./Meas. pt. (MPi)/Measuring point

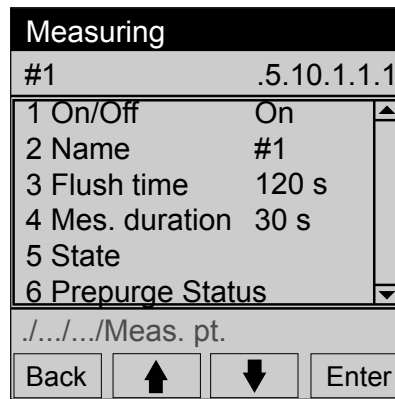

- 1 Activation status
- 2 Programmed name of the measuring point
- 3 Set flush time
- 4 Set measuring time
- 5 Status
- 6 Prepurging status

Activating/deactivating the measuring point

1. Select **On/Off** (↓/↑, Set)
2. Select the desired state (↓/↑, Save)

On	This measuring point is used for measuring point switchover
Off	This measuring point is ignored for measuring point switchover

Setting the measuring point name

1. Select **Name** (↓/↑, Set).
2. Set the desired name.

Setting the flush time

1. Select **Flush time** (↓/↑, Set).
2. Set the desired flush time.



NOTE

Information on correct setting: See “Operating Instructions BCU” Chapter “Setting the flush time for adjustments”.

Setting the measuring time

1. Select **Measuring time** (↓/↑, Set).
2. Set the desired measuring time.



NOTE

Current measured values are determined for this measuring point during the measuring time. The total time for the measuring point is flush time + measuring time.

Assigning a status output for the measuring point

The assigned digital output is used to control a solenoid valve that switches the sample gas path on this measuring point. The digital output is activated during the time the measuring point is activated. The electronic switching logic can be inverted.

1. Select **Status** (↓/↑, Enter).
2. Select the desired digital output (↓/↑, Set).
3. Select the electronic switching logic in the next menu (↓/↑, Save).



NOTE

- These settings are also available elsewhere: See “Operating Instructions BCU” Chapter “Assigning a digital output to a status or control function”.
- Explanation of the electronic switching logic: See “Operating Instructions BCU” Chapter “Selecting the electronic switching logic”.

6.9.2 Assigning a status output for the switchover phase

Menu: Parameter/Special fct./Meas. point autom./Status (MPS)

1. Select the desired digital output (↓/↑, Set).
2. Select the electronic switching logic in the next menu (↓/↑, Save).

Purpose

The assigned digital output indicates whether the automatic measuring point switchover is in the flush phase or the measuring phase:

Logical state of the digital output	Significance
0	Flush time
1	Meas. duration

6.9.3 Selecting the measuring point display

Menu: Parameter/Special fct./Meas.point autom./Meas.values

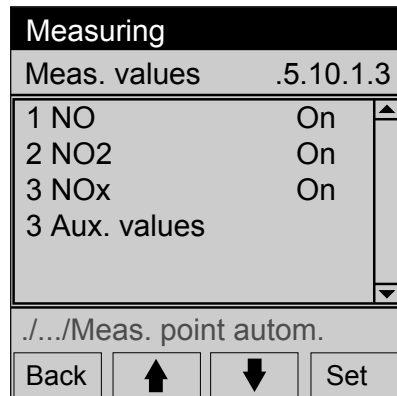

1. Select a measuring component (↓/↑, Set).
To select an auxiliary value: Select **Aux. values** and then select the desired auxiliary value.
2. Select the desired state (↓/↑, Save).

On	The current measured value and the measured values for the measuring points are available in menus and measured value displays (example: See “Operating Instructions BCU” Chapter “Displaying measured values as mA values”)
Off	Only the current measured value is available for the measuring component in menus and measured value displays

6.10 Language

Menu: Language

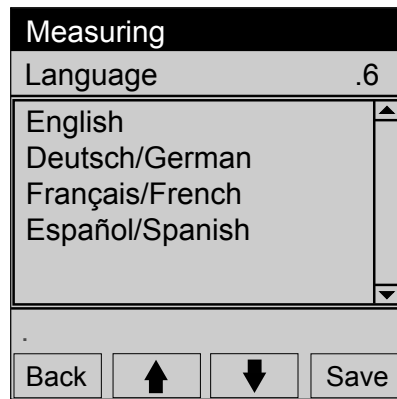

Figure 21: *Language* menu (example)

- ▶ Select the desire language. (↓/↑, Save).

7 Maintenance

7.1 Important information

Requirements for the maintenance personnel

- The technician must be familiar with the exhaust gas technology of the operator's plant (overpressure, toxic and hot sample gases) and be able to avoid hazards when working on gas ducts.
- The technician must be familiar with handling compressed gas cylinders (test gases).
- The technician must be able to avoid hazards caused by noxious test gases.
- The technician must be familiar with gas lines (PTFE lines) and their screw fittings (be able to ensure gas-tight connections).
- Only allow an authorized electrician to work on the electrical system or electrical subassemblies.

- Acid condensate could escape when working on the sample gas lines and the associated subassemblies.



CAUTION

Risk of chemical burns by acid medium

- ▶ Take appropriate protective measures for work (for example, by wearing a safety mask, protective gloves and acid resistant clothes).
 - ▶ In case of contact with the eyes, rinse immediately with clear water and consult a doctor.
-



ATTENTION

Spare parts: Observe 115 V or 230 V versions.

Some spare parts are available in different voltage versions.

Before installing a spare part, check whether it is voltage-dependent (see ["Consumable parts, wearing parts and spare parts"](#), page 116).

See the type plates for the power voltage of your system.

Observe the following:

- ▶ After working on the gas path: Perform a leak tightness check: see ["Leak tightness check"](#), page 73.
 - ▶ Inlet "P" of valve KK10 in the sample conditioning must have a dummy plug. (The dummy plug is fitted as standard).
 - ▶ After exchanging subassemblies: Put the system back into operation: see ["Commissioning"](#), page 21.
 - ▶ After exchanging a test gas cylinder: Configure the new test gas concentration: see ["Configuring the test gases"](#), page 61.
-

NOTICE

Observe the torques of the screw connections: see ["Torques for screw fittings"](#), page 107.



NOTE

Consumable parts, wearing parts and spare parts: see ["Consumable parts, wearing parts and spare parts"](#), page 116.

7.2 Tube screw fitting

Swagelok screw fitting

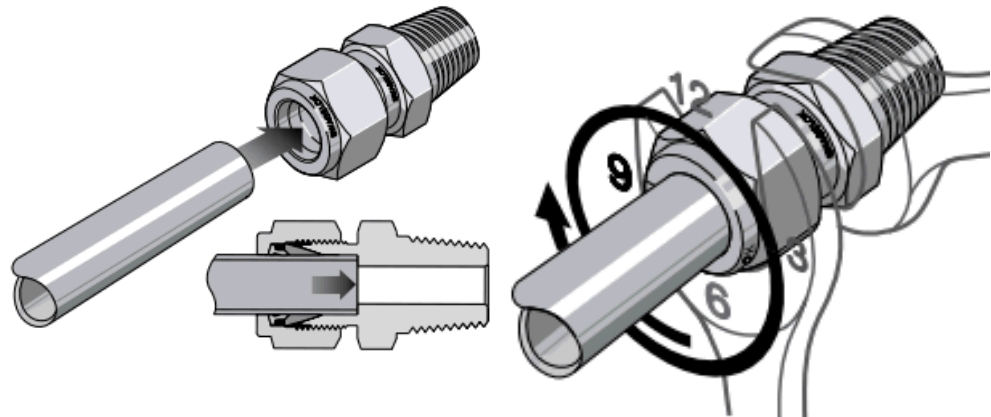

- ▶ Push the tube up to the stop in the tube screw fitting. Turn the cap nut finger-tight.
- ▶ During initial assembly: Hold the fitting bolt steady and tighten the cap nut with 1 1/4 revolutions.
- ▶ During refitting: Tighten the cap nut to the previous position (the resistance increases noticeably) and then slightly tighten.

Plastic fitting

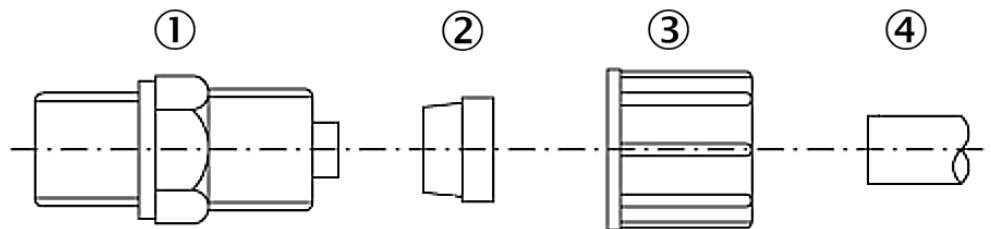
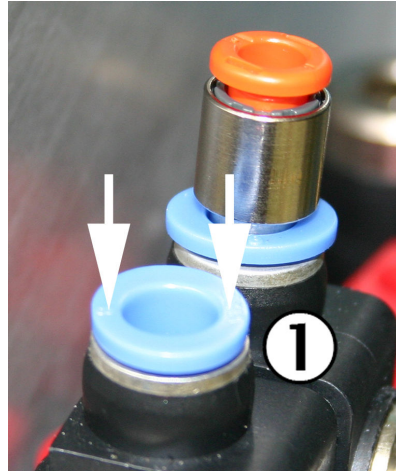

Figure 22: Hose fitting

- ① Screw-in piece
- ② Clamping ring
- ③ Knurled nut
- ④ Hose

- ▶ Place the knurled nut and the clamping ring on the hose. Observe the location of the clamping ring (see drawing).
- ▶ Place the hose on the screw-in piece.
- ▶ Turn the knurled nut hand-tight.

Push-in fitting pneumatic



① Retaining ring

- ▶ Inserting the tube: Push the tube in.
- ▶ Removing the tube: Press the retaining ring in and pull the tube out.

7.3 Maintenance plan



NOTICE

This Maintenance plan describes the maintenance work specified by the manufacturer. Inspections according to the Guidelines to be implemented by the operating company (e.g., MARPOL Annex VI) must be performed in accordance with the intervals described therein.

Table 5: Maintenance intervals

Interval ¹	Maintenance work	Remark
1W	Visual check of fine filter.	see "Check and replace the sample gas fine filter", page 72.
1M	Visual inspection of the system.	see "Check", page 69.
3M	Check all gas lines for tight seat.	Check all gas line inlets for tight seat.
	Check the filter of the gas sampling probe.	see "Maintenance of gas sampling probe", page 69.
	Check the adjustment including test gas feed on the system.	see "Adjustment functions", page 35
6M	Check the cooler.	See the Operating Instructions of the cooler.
	Carry out the leak tightness check.	see "Leak tightness check", page 73.
	Replace hose and wrapping tape of the hose pump.	see "Replacing hose and wrapping tape of the hose pump", page 71
1Y	Replace the water trap.	see "Check and replace the water trap", page 73.
2Y	For DeNO _x version: Replace the DEFOR UV lamp.	Replace the complete analyzer module: see "Removing and fitting the complete analyzer module", page 92
	Replace the sample gas pump.	see "Replacing the sample gas pump", page 81
	Replace the O ₂ module (OXOR E).	see "Replacing the O2 module (OXOR E)", page 90
4Y	For DeSO _x version: Replace the DEFOR UV lamp.	Replace the complete analyzer module: see "Removing and fitting the complete analyzer module", page 92

¹ 1D = Daily, 1W = Weekly, 1M = Monthly, 3M = Every 3 months, 6M = Every 6 months, 1Y = Yearly

7.4 Check

Check device and its environment

- ▶ Check all fastening screws of the enclosures for tight seat.
- ▶ Check the condensate outlet for clogging; check the fill level of the collecting container, if required.
- ▶ Check PTFE lines for kinks.
- ▶ Check all hose fittings for tight seat.
- ▶ Check system cabinets for cleanness, dryness and freedom from corrosion.
- ▶ Check all electric connections for freedom from corrosion and firm seat.
- ▶ Check grounding conductors are free from corrosion.
- ▶ Check the test gases:
 - Use-by date
 - Fill level
 - Condition of cylinders

Check operation

- ▶ Check the display of the control unit for pending error messages.
- ▶ Check measured values for plausibility.
- ▶ Check the flow on the flowmeter (in the distribution unit): Approx. 60 l/h. Set on the flowmeter when necessary.
- ▶ To check whether the sample gas line is heating: The sample gas line must be clearly warmer than the ambient temperature.

7.5 Maintenance of gas sampling probe



CAUTION

Caution: Hot surfaces

- ▶ Before working on the sampling probe: Allow the sampling probe to cool down.

1. Switch the system off completely; observe the flush time: see "[Stand-by and switching off](#)", page 94.
2. Stop the instrument air feed to the sample conditioning.

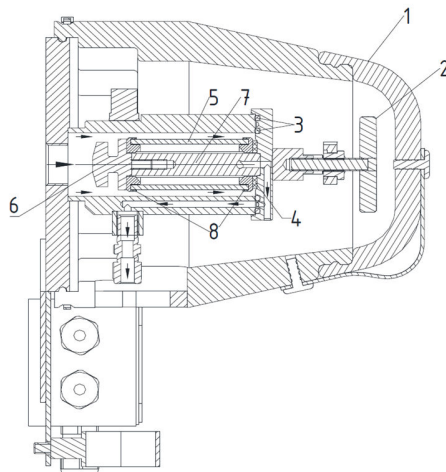

3. Press insulating cap (1) together and pull off.
CAUTION! Do not pull on the green retaining strap otherwise the insulating cap will be damaged.

- Loosen the probe cover by turning grip 2 to the left and pull out with O-ring seals (3), filter element seal (4), filter element (5), with filter element holder (7), both adapters (8) and knurled filter screw (6).
- Turn out knurled filter screw (6) and replace filter element (7) and, at the same time, check adapter (8) and replace when necessary.
- Check filter element seals (4) and exchange when necessary.
- Check O-ring (3) of the probe cover and exchange when necessary.
- Clean the filter chamber. Poke through the sampling pipe when deposits exist. Check the condition of the sampling tube.
- Reassemble in reverse sequence. To close the cover, position the lock on the separator bolt and turn grip (2) tight to the right.
- Open the instrument air again immediately.
- Switch the system on again immediately: [see "Switching on", page 21](#).

Avoid cold bridges

No cold bridges may occur on the sample gas line connection on the gas sampling probe.

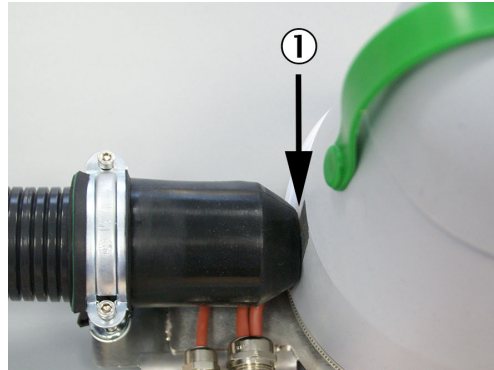

- ① No cold bridges here, close flush or insulate

7.6 Cooler maintenance

The cooler is located in the sample conditioning.



CAUTION

Risk of chemical burns by acid medium

- ▶ Take appropriate protective measures for work (for example, by wearing a safety mask, protective gloves and acid resistant clothes).
- ▶ In case of contact with the eyes, rinse immediately with clear water and consult a doctor.



NOTE

The sample gas cooler is system-specific.

- ▶ For maintenance work, see the enclosed Operating Instructions of the sample gas cooler.
-

1. Set the Stand-by switch on the distribution unit to “ON” and wait for the sample gas flow to stop: [see "Stand-by and switching off", page 94](#).
2. Switch off fuses FC2 to FC5 in the distribution unit ([see "Distribution unit", page 17](#)).
3. Check the sample conditioning is disconnected from the power supply and potential-free (the indicators on the cooler are off).
4. Perform maintenance work on the cooler: See the Operating Instructions of the cooler.
5. Switch the fuses on again.
6. Switch the system on again: [see "Switching on", page 21](#).

7.7 Replacing hose and wrapping tape of the hose pump



The hose pump is located on the cooler in sample conditioning ([see "Sample conditioning", page 15](#)).

Spare parts set: [see "Consumable parts, wearing parts and spare parts", page 116](#).



CAUTION

Risk of chemical burns by acid medium

- ▶ Take appropriate protective measures for work (for example, by wearing protective goggles and appropriate clothes).
- ▶ In case of contact with the eyes, rinse immediately with clear water and consult a doctor.



NOTE

The hose pump is part of the sample gas cooler.

The sample gas cooler is system-specific.

- ▶ For maintenance work on the hose pump, see the enclosed Operating Instructions of the sample gas cooler.

1. Set the Stand-by switch on the distribution unit to “ON” and wait for the sample gas flow to stop: [see "Stand-by and switching off", page 94](#).
2. Switch off fuses FC2 to FC5 in the distribution unit ([see "Distribution unit", page 17](#)).
3. Check the sample conditioning is disconnected from the power supply and potential-free (the indicators on the cooler are off).
4. Perform maintenance work on the hose pump: See the Operating Instructions of the hose pump.
5. Switch the fuses on again.
6. Switch the system on again: [see "Switching on", page 21](#).

7.8 Check and replace the sample gas fine filter



Figure 23: Sample gas fine filter (system-specific)

The sample gas fine filter is located in the distribution unit.

1. Check the sample gas fine filter for contamination (discoloring).
White color: The sample gas fine filter is okay.
Otherwise replace the sample gas fine filter.
2. Set the Stand-by switch on the distribution unit to “ON” and wait for the sample gas flow to stop: [see "Stand-by and switching off", page 94](#).

NOTE

The sample gas fine filter is system-specific.

- The maintenance on the sample gas fine filter is described here in an example.

-
3. Loosen the cap nuts of the sample gas hoses and pull the hoses out of the screw fitting.
Do not lose the clamping rings.
 4. Take out the filter.
 5. Insert the new filter.
The fitting direction of the sample gas fine filter is irrelevant.
 6. Refit the hose connections: [see "Tube screw fitting", page 67](#).
 7. Check the gas tightness of the sample gas path: [see "Leak tightness check", page 73](#).
 8. Set the stand-by switch to “OFF” again.

7.9 Check and replace the water trap

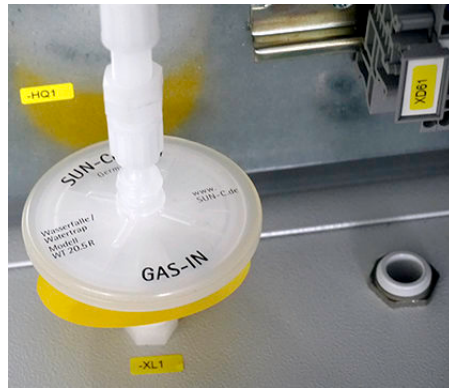

Figure 24: Water trap (system-specific)

The water trap is located in the distribution unit.

1. Check the water trap for contamination (discoloring) or replace after one year.
2. When a new water trap is fitted: Note the installation date on the water trap.
3. Set the Stand-by switch on the distribution unit to “ON” and wait for the sample gas flow to stop: see ["Stand-by and switching off"](#), page 94.



NOTE

The water trap is system-specific

- ▶ The maintenance on the water trap is described here in an example

4. Loosen the cap nuts of the sample gas hoses on the water trap side and pull the hoses out of the screw fitting.
5. Insert a new water trap.
6. Refit the hose connections: see ["Tube screw fitting"](#), page 67.
7. Check the gas tightness of the sample gas path: see ["Leak tightness check"](#), page 73.
8. Set the stand-by switch to “OFF” again.

7.10 Leak tightness check



CAUTION

Live connections are located next to the sample gas pump

- ▶ Do not touch any live connections.



NOTE

The following is required: “Leak tightness check spare parts set” (see ["Consumable parts, wearing parts and spare parts"](#), page 116).

When several measuring points are fitted: In the measuring point switchover (see ["Measuring point switchover \(measuring point automatic\)"](#), page 62), only activate the desired measuring point and deactivate all other measuring points for the duration of the leak tightness check.

Test procedure

1. View the flow on the control unit (menu: Diagnosis/Status/Limit values/Aux. val-ues): The flow shown on the display must be “60 l/h”.

- ▷ If a different value is shown: Use the flow controller (in the distribution unit) to set the value shown on the display to “60 l/h”.
- 2. Unscrew the heated sample gas line on the sampling probe.
- 3. Close the gas inlet of the heated sample gas line gas-tight with the sealing plug from the spare parts set.



CAUTION

The connection is hot

- ▶ Do not touch any hot components.

- 4. Switch off the bypass pump at fuse FC7 in the distribution unit.
- 5. Unscrew the line on the pump inlet. Mark line and inlet.
- 6. Unscrew the line from the pump outlet. Mark line and outlet.



- ① Pump inlet
- ② Pump outlet

- 7. Screw both line ends together gas tight with the coupling from the spare parts set.



- 8. Connect the PTFE line of the spare parts set to the pump inlet.



- 9. Connect the other end of the PTFE line to the sample gas outlet of the analyzer (is marked).
 Note: Use the full length of the PTFE line of the “Leak tightness check” spare parts set. If the line is too short, oscillations occur in the standing gas column and a flow rate is erroneously displayed.
- 10. The flow displayed must be ≤ 0.3 l/h.
- 11. Unscrew the PTFE line of the spare parts set again.

12. Refit the sample gas outlet on the analyzer.
13. Connect line "2" to the pump according to the markings made.
 - The flowmeter shows 60 l/h. If not: Check the correct line is connected.
14. Switch on the bypass pump on fuse FC7 in the distribution unit.
15. Connect line "1".
16. Remove the lock on the inlet of the heated sample gas line.
17. Reconnect the heated sample gas line to the sampling probe.

**NOTE**

Alternative test methods:

- Using the SICK "pressure test tool".
 - Using a mass flow rate controller.
 - On devices with O₂ sensor: Feed nitrogen without pressure to the sampling probe. The oxygen content must then be "0".
-

8 Troubleshooting

8.1 Important information

Requirements for the maintenance personnel

- The technician must be familiar with the exhaust gas technology of the operator's plant (overpressure, toxic and hot sample gases) and be able to avoid hazards when working on gas ducts.
- The technician must be familiar with handling compressed gas cylinders (test gases).
- The technician must be able to avoid hazards caused by noxious test gases.
- The technician must be familiar with gas lines (PTFE lines) and their screw fittings (be able to ensure gas-tight connections).
- Only allow an authorized electrician to work on the electrical system or electrical subassemblies.
- Acid condensate could escape when working on the sample gas lines and the associated subassemblies.



CAUTION

Risk of chemical burns by acid medium

- ▶ Take appropriate protective measures for work (for example, by wearing a safety mask, protective gloves and acid resistant clothes).
- ▶ In case of contact with the eyes, rinse immediately with clear water and consult a doctor.



ATTENTION

Spare parts: Observe 115 V or 230 V versions.

Some spare parts are available in different voltage versions.

Before installing a spare part, check whether it is voltage-dependent (see ["Consumable parts, wearing parts and spare parts"](#), page 116).

See the type plates for the power voltage of your system.

Observe the following:

- ▶ After working on the gas path: Perform a leak tightness check: see ["Leak tightness check"](#), page 73.
- ▶ Inlet "P" of valve KK10 in the sample conditioning must have a dummy plug. (The dummy plug is fitted as standard).
- ▶ After exchanging subassemblies: Put the system back into operation: see ["Commissioning"](#), page 21.
- ▶ After exchanging a test gas cylinder: Configure the new test gas concentration: see ["Configuring the test gases"](#), page 61.

NOTICE

Observe the torques of the screw connections: see ["Torques for screw fittings"](#), page 107.



NOTE

Consumable parts, wearing parts and spare parts: see ["Consumable parts, wearing parts and spare parts"](#), page 116.

8.2 Malfunctions (Table)



NOTE

Malfunction messages are saved in the MARSIC200 logbook: see ["Displaying the logbooks"](#), page 58.

Overview of the error messages and possible troubleshooting: see ["Logbook messages"](#), page 109.

Flow too low

Possible cause	Information
Sampling tube clogged or filter element in sampling probe contaminated	Clean the sampling probe see "Removing and fitting the sampling probe" , page 78 and see "Maintenance of gas sampling probe" , page 69
Sample gas line clogged	
	Check
Wrong flow setting	The flow must be approx. 60 l/h: Set at the flowmeter (in the distribution unit)
Sample gas fine filter or water trap clogged	Check and replace, as required

Test gas adjustment implausible or measured value display implausible

Possible cause	Information
The device is still cold	Wait for warming up time to elapse
Test gas and set test gas concentration do not match	
	Check the test gas concentration: see "Configuring the test gases" , page 61
Test gas unreliable	Check the test gas: Setpoint value, service life, pressure, lines
Gas path clogged	Check and clear clogging
Gas path leaky	Perform the leak tightness check: see "Leak tightness check" , page 73
Sample gas pump defective	Check sample gas pump
Damaged subassemblies	Visual inspection on the outside and inside of all enclosures Check fine filter and water trap Check cooler
Flow too low	See Table above
Strong power voltage fluctuations	Check of power voltage

Zero point drifting or sensitivity drifting

Possible cause	Information
Gas path leaky or clogged.	Check the gas path: Clogging, leak tightness
Cooler unstable	Check the cooler
Test gas unreliable.	Check the test gas: Setpoint value, service life, pressure, lines
Flow too low.	See Table above

Errors on signal lines

Possible cause	Information
Connections loose / corroded	Check all affected connections

Possible cause	Information
Electromagnetic interference	Protective conductors missing in the operator's own power supply. Voltage peaks in the network. Large machine with intermittent operation. Strong radio transmitter in the vicinity / close enclosure doors. Insufficient / corroded grounding.
Inadequate power supply in the analyzer enclosure	Check
Check the interfaces	See "Technical Information MARSIC200"

8.3 Removing and fitting the sampling probe



WARNING

Hazard through high pressure, hot and toxic exhaust gases

- ▶ Remove the sampling probe only when the exhaust duct is without pressure/the motor is switched off.
- ▶ Wear suitable protective clothes.



NOTE

The sampling probe is system-specific

- ▶ Further information on maintenance of the sampling probe, see Operating Instructions of the sampling probe.

Removing

1. Set the Stand-by switch on the distribution unit to **ON** and wait for the sample gas flow to stop: [see "Stand-by and switching off", page 94](#).
2. Flush with instrument air until the probe is only lukewarm.
3. Switch the system off completely: [see "Stand-by and switching off", page 94](#).
4. Switch the instrument air off.
Remove the probe with sampling tube swiftly, otherwise the sampling tube could be contaminated.
5. Unscrew the sample gas line (marked with a **red** ring).
Do not lose the cutting rings.
6. Unscrew the instrument air line (marked with a **blue** ring).
Do not lose the cutting rings.
7. Unscrew the power supply.
8. Note the position of the signal lines and unscrew the signal lines.
9. Pull the sampling probe: See the Operating Instructions of the sampling probe.

Fitting

1. Fitting the sampling probe in the gas duct: See the Operating Instructions of the sampling probe.
Perform the following work swiftly, otherwise the sampling tube could be contaminated.
2. Connect the signal lines according to the notes taken.
3. Connect the instrument air line (marked with a blue ring) ([see "Tube screw fitting", page 67](#)).
 - Tighten the nut finger-tight.
 - Tighten the nut with a flat key by 1¼ turns.
4. Connect the sample gas line (marked with a **red** ring).
5. Check the red mark (sample gas line) and the blue mark (instrument air line) match the connections on the sample gas cooler ([see "Sample conditioning", page 15](#)).

6. Attach the strain relief of the heated sample gas line.
7. Switch on the instrument air.
8. Connect power supply: See the Operating Instructions of the sampling probe.
9. Switch the system on again: [see "Switching on", page 21.](#)

8.4 Replacing the heated sample gas line



WARNING

Danger to life by electric voltage

- ▶ Only allow an authorized electrician to work on the electric system

Removing

1. Switch the system off completely; observe the flush time: [see "Stand-by and switching off", page 94](#)
2. Disassembly on the sample conditioning:
 - ▷ Unscrew electric lines in the terminal box.
 - ▷ Unscrew the line duct at the sample conditioning (see Figure below).
Unscrew 2 clamping screws and 4 frame screws for this purpose.
 - ▷ Unscrew the sample gas line on the cooler and on the purge valve.
3. Disassembly on the sampling probe: [see "Removing and fitting the sampling probe", page 78.](#)
4. Remove the sample gas line.

Fitting

- Lay the sample gas line, starting from the sample conditioning towards the sampling probe.



ATTENTION

Observe the laying instructions for the sample gas line (are enclosed with the sample gas line).

No cold bridges may occur: Insulate all uninsulated connections with heat-resistant insulation material.

Assembly on the sampling probe



ATTENTION

Do not damage the core of the sample gas line

- ▶ A hose cutter must be used to cut off the core.
- Shorten the PTFE core of the heated sample gas line to the length of the cap nut of the screw fitting.
- Assembly on the sampling probe: [see "Removing and fitting the sampling probe", page 78.](#)

Assembly on the sample conditioning

1. Clamp the cable bushing on the corrugated hose approx. 10 cm behind the start of the corrugated hose.
The groove on the cable bushing must point away from the hose end.

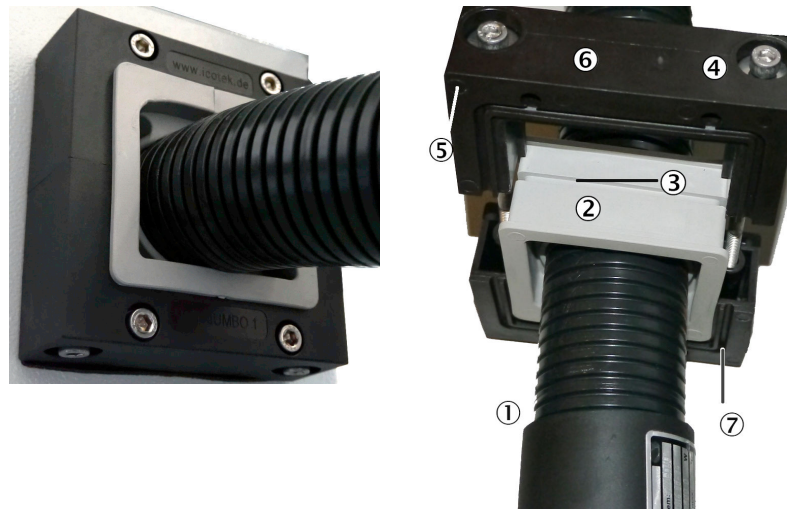

- ① Corrugated hose
- ② Cable bushing
- ③ Groove in cable bushing
- ④ 2 clamping screws (from below or above)
- ⑤ 4 frame screws
- ⑥ Frame
- ⑦ Groove in frame

2. Push the frame with 2 clamping screws over the cable bushing and fasten lightly. The groove of the frame must point towards the hose end (in the direction of the enclosure side).
3. Insert the line in the enclosure.
4. Preassemble the frame on the enclosure.
5. Align the sample gas line so that the electric line points upwards.
 - The line marked **red** (sample gas) must continually lead downwards (danger of clogging by condensate).
6. Connect the lines:
 - ▷ The line marked **red** on the cooler inlet (cooler is system-specific).
 - ▷ The line marked **blue** on the solenoid valve KK10.

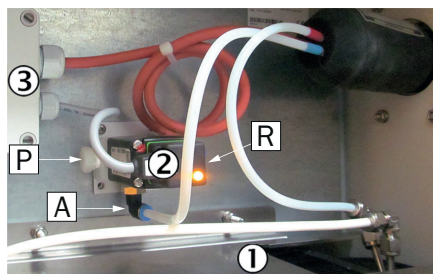

- ① Sample gas cooler (system-specific)
- ② Solenoid valve KK10 for feeding test gas to the sampling probe
- ③ Terminal box
- R Instrument air connection
- P Connection of span gas/test gas
- A Connection to heated sample gas line

7. Screw the lines tight (see "Tube screw fitting", page 67).
8. Check the red mark (sample gas line) and the blue mark (instrument air line) match the connections on the sample gas cooler (see Operating Instructions, Chapter "Removing and fitting the sampling probe").
9. Screw the frame tight (1.5 Nm).

10. Screw the clamping screws tight (1.5 Nm).
11. Electrical connection: See the wiring diagram on the inside of the terminal box cover.
 - Core cross-section: 1.5 mm².
 - Connections: BK 1, BK 2, GNYE: See identification rings on the crimp lead end sleeves.
12. Check the gas tightness of the sample gas path: [see "Leak tightness check", page 73.](#)
13. Switch the system on again: [see "Switching on", page 21.](#)

8.5 Replacing the sample gas pump

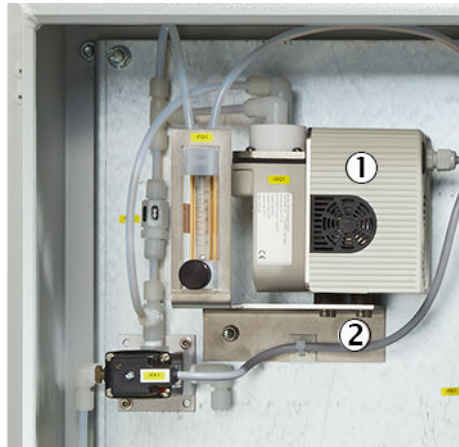

Figure 25: Sample gas pump in distribution unit

- ① Sample gas pump
- ② 4 screws



WARNING

Danger to life by electric voltage

- ▶ Only allow an authorized electrician to work on the electric system



WARNING

The sample gas pump can be hot

- ▶ Allow the sample gas pump to cool down.
- or
- ▶ wear suitable protective clothes, for example, heat-resistant gloves.

Removing

1. Switch the system off completely; observe the flush time: [see "Stand-by and switching off", page 94.](#)
2. Mark the position of the hoses.
3. Unscrew the hoses.
4. Disconnect the electric connection on the terminal strip.
5. Unscrew 4 screws on the underside of the pump and take out the pump.

Fitting

1. Screw on the pump (2 Nm)
2. Connect the hoses according to the marking made: see ["Tube screw fitting"](#), page 67
The inlet and outlet of the pump are marked:
 - "IN": Hose coming from the valve (this is the longest hose)
 - "OUT": Hose leading to the flowmeter
3. Electrical connection: See the wiring diagram in the system documentation
4. Check the gas tightness of the sample gas path: see ["Leak tightness check"](#), page 73
5. Switch the system on again: see ["Switching on"](#), page 21.

8.6 Replacing the solenoid valve

Figure 26: Solenoid valve (example)

**WARNING**

Danger to life by electric voltage

- ▶ Only allow an authorized electrician to work on the electric system

This description is applicable for:

- Purge gas valve in the sample conditioning
- Sample gas valve in the distribution unit
- Solenoid valve for valve block in the distribution unit

Removing

1. Switch the system off completely; observe the flush time: see ["Stand-by and switching off"](#), page 94.
2. Mark the position of the hoses.
3. Unscrew the hoses.
4. Unscrew the valve plug with the electric connection.
5. Unscrew the valve.

Fitting

1. Fit the new valve and screw tight (2 Nm).
2. Screw on the hoses according to the marking made: see ["Tube screw fitting"](#), page 67.
The valve inlets and outlets are marked with letters: See system documentation for the hosing.
3. Reconnect the plugs and screw tight (0.35 Nm).
4. The free inlets of the valve must have a dummy plug.

5. Check the gas tightness of the sample gas path: see ["Leak tightness check"](#), page 73.
6. Switch the system on again: see ["Switching on"](#), page 21.

8.7 Replacing the sample gas cooler

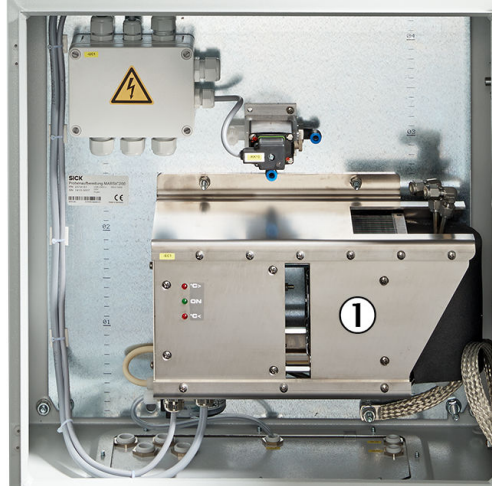

Figure 27: Sample gas cooler (system-specific)

- ① Sample gas cooler (system-specific)



NOTE

The sample gas cooler is system-specific.

For further information concerning the sample gas cooler, see the Operating Instructions of the sample gas cooler.



WARNING

Danger to life by electric voltage

- ▶ Only allow an authorized electrician to work on the electric system

Removing

1. Switch the system off completely; observe the flush time: see ["Stand-by and switching off"](#), page 94.
2. Unscrew the sample gas inlet.
3. Unscrew the sample gas outlet.
4. Unscrew the condensate outlet.
5. Disconnect the electric connection on the terminal strip.
6. Unscrew the fastening screws on the cooler and take the cooler out.

Fitting

1. Insert the cooler and screw tight (6 Nm).
2. Screw the PTFE core of the heated sample gas line (red marking) to the gas inlet (marked with an arrow) (see ["Tube screw fitting"](#), page 67).
3. Screw the PTFE line (to the distribution unit) to the sample gas outlet (marked with an arrow).
4. Connect condensate outlet.
5. Electrical connection: See the wiring diagram (the wiring diagram is printed on the inside of the cover).

6. Check the gas tightness of the sample gas path: see ["Leak tightness check"](#), page 73.
7. Switch the system on again: see ["Switching on"](#), page 21.

8.8 Replacing the power supply unit of the distribution unit



Figure 28: Power supply unit of the distribution unit

- ① Power supply unit



WARNING

Danger to life by electric voltage

- Only allow an authorized electrician to work on the electric system

Removing

1. Switch the system off completely; observe the flush time: see ["Stand-by and switching off"](#), page 94.
2. Disconnect the electric lines.
 - Supply voltage
 - Control voltage

TIP: Mark the two blue lines +24 V and 0 V to prevent interchanging them during connection.
3. Unlatch the power supply unit from the DIN rail.

Fitting

1. Lock the new power supply unit into place in the DIN rail.
2. Electrical connections: Connect the blue lines +24 V and 0 V according to the marking made.
See wiring diagram.
3. Switch the system on again: see ["Switching on"](#), page 21.

8.9 Replacing the analyzer door

8.9.1 Replacing the control unit (BCU) an analyzer door

The control unit (BCU) is delivered completely assembled with the upper analyzer door, hinges and ground strap.

The control unit has a standard configuration and is configured ready for use.



NOTICE

Onsite settings must be performed individually: See “Technical Information MARSIC200”.

If you have made individual settings on the control unit: Inform your contact partner already when ordering a new analyzer door; the settings can then be transferred to the new control unit.

Removing

1. Set the Stand-by switch on the distribution unit to “ON” and wait for the sample gas flow to stop: (see ["Stand-by and switching off", page 94](#)).
2. Wait for 1 minute (sample gas path being flushed).
3. Switch off fuse FC8 (analyzer) (see ["Distribution unit", page 17](#)).
4. Switch off the On/Off switch of the analyzer (position: top right in analyzer top part, see ["Analyzer", page 18](#)).
5. Check the analyzer is free from voltage: All LEDs of the display must be OFF.
6. On the display (BCU), unlock and pull the RJ45 plug (yellow) and RJ45 plug (green).
7. Remove the cable from the door.
8. Unscrew the ground strap from the device (not from the door). Keep Allen screw and 3 washers for further use.
9. Mark the installation position of the hinges on the analyzer enclosure (for easier alignment of door after installation).
10. Secure door against falling.
11. Loosen the nuts of the hinges on the analyzer enclosure and keep them for further use.
12. Carefully take the door off to avoid damage to the gasket.

Fitting

1. Position the door on the analyzer enclosure.
2. Attach the door with the 4 nuts lightly on the enclosure.
3. Align the hinges according to the marking and tighten fully.
4. Attach the ground strap in the analyzer enclosure.
5. The sequence of the washers and spring washers for the screw connection is shown on the attachment in the door.
6. Insert the RJ45 plug (yellow) in the bottom socket and the RJ45 plug (green) in the top socket on the display.
7. Fasten the cable to the door.
8. Close the door and check the fit (screw connections).
9. Switch device on.

8.9.2 Replacing the bottom analyzer door

Removing

1. Unscrew 2 x ground strap from the device (not from the door). Keep Allen screw and 3 washers for further use.
2. Mark the installation position of the hinges on the analyzer enclosure (for easier alignment of door after installation).
3. Secure door against falling.
4. Loosen the nuts of the hinges on the analyzer enclosure and keep them for further use.
5. Remove the door.

1. Position the door on the analyzer enclosure.
2. Attach the door with the 4 nuts lightly on the enclosure.
3. Align the hinges according to the marking and tighten fully.
4. Attach 2 x ground strap in the analyzer enclosure.
5. The sequence of the washers and spring washers for the screw connection is shown on the attachment in the door.
6. Close the door and check the fit (screw connections).

8.10 Replacing the analyzer

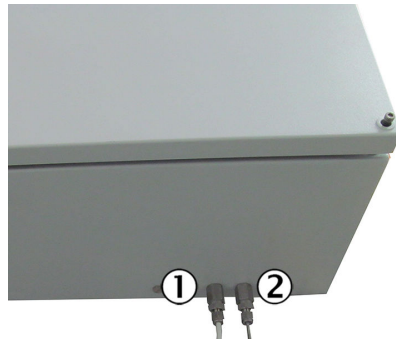

Figure 29: Sample gas connections on analyzer

- ① Sample gas inlet (seen from the front, bottom left)
- ② Sample gas outlet (seen from the front, bottom right)

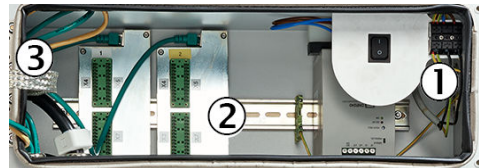

Figure 30: Electrical connections in analyzer

- ① Power voltage connection at terminal strip
- ② Signal connections (I/O)
- ③ Distributor board with Ethernet for MPR (option), Modbus, service interface (LAN)

The new analyzer has a standard configuration and is configured ready for use.



NOTICE

Onsite settings must be performed individually: See “Technical Information MAR-SIC200”.

If you have made individual settings: Inform your contact partner already when ordering a new analyzer; the settings can then be transferred to the new analyzer.



WARNING

Danger to life by electric voltage

- ▶ Only allow an authorized electrician to work on the electric system

Removing

1. Switch the system off completely; observe the flush time: see "[Stand-by and switching off](#)", page 94.
2. Disconnect the power supply on the power supply unit.
3. Mark and disconnect the signal lines.
4. Unscrew the sample gas line inlet.
5. Unscrew the sample gas line outlet.
6. Unscrew 4 wall fastening screws and take off the analyzer.

Fitting

1. Screw on the analyzer with 4 wall fastening screws.
2. Screw on the sample gas line inlet (see "[Tube screw fitting](#)", page 67). Ensure gas tightness.
3. Screw on the sample gas line outlet.

4. Connect the signal lines according to the marking made. See enclosed wiring diagram.
5. Connect the power supply to the power supply unit.
6. Switch the system on again: see "Switching on", page 21.

8.11 Replacing the analyzer power supply unit

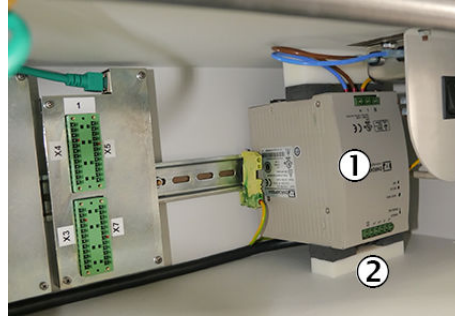

Figure 31: Power supply unit in the analyzer

- ① Power supply unit
- ② Bottom damping block



WARNING

Danger to life by electric voltage

- Only allow an authorized electrician to work on the electric system

Removing

1. Set the Stand-by switch on the distribution unit to "ON" and wait for the sample gas flow to stop: see "Stand-by and switching off", page 94.
2. Switch off the fuse FC8 (power supply unit) in the distribution unit (see "Distribution unit", page 17).
3. Check that the analyzer is free from voltage: All LEDs of the display must be OFF.
4. Open the upper enclosure door of the analyzer.
5. Pull out the bottom damping block.
(Do not pull out the top damping block).
6. Pull the DIN rail/spring attachment at the top of the power supply unit upwards and take the power supply unit off the DIN rail.
Caution: Do not rip the electric lines off.
7. Disconnect all electric lines.
8. Take out the power supply unit.

Fitting

1. Connect the grounding cable.
2. Connect power supply.
3. Connect the 24 V power supply. Observe the polarity.
4. Hang the power supply unit from below into the DIN rail and press upwards until the DIN rail/spring attachment latches in.
5. Push the bottom damping block between the power supply unit and the bottom plate.
6. Close the enclosure door of the analyzer top part again.
7. Switch the fuse in the distribution unit on again.
If the power supply unit makes a whistling sound: Switch the fuse off immediately and check the 24 V polarity of the voltage connection on the power supply unit.

8. Close the enclosure door of the distribution unit again.
9. Set the stand-by switch to "OFF" again.

8.12 Analyzer fuse

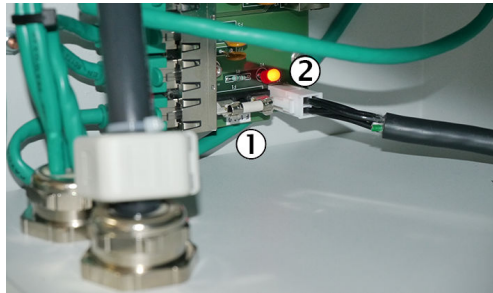

Figure 32: Fuse

- ① Fuse
- ② LED

The analyzer fuse is on the left in the analyzer top part.

LED is on	The fuse is okay
LED is OFF	The fuse is defective



WARNING

Danger to life by electric voltage

- Only allow an authorized electrician to work on the electric system

Replacement of fuse

1. Switch off the On/Off switch of the analyzer top part (position: top right in analyzer top part, [see "Analyzer", page 18](#)).
2. Check that the analyzer is free from voltage: All LEDs of the display must be OFF.
3. Replacement of fuse.
Important: Only use a fuse with identical characteristics.
4. Switch the On/Off switch on again.
5. Close the enclosure door again.

8.13 Replacing the CO₂ module (FINOR)

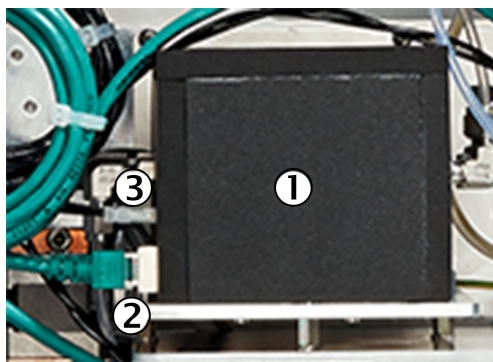

Figure 33: FINOR module

- ① FINOR module
- ② Position of RJ45 plug
- ③ Position of 24 V plug

The FINOR module (measurement of CO₂) is in the analyzer bottom part.



WARNING

The FINOR can be hot

- ▶ Allow FINOR to cool down.
- or
- ▶ wear suitable protective clothes, for example, heat-resistant gloves.

Removing

1. Set the Stand-by switch on the distribution unit to “ON” and wait for the sample gas flow to stop: (see ["Stand-by and switching off", page 94](#)).
2. Wait for 1 minute (sample gas path being flushed).
3. Switch off fuse FC8 (analyzer) (see ["Distribution unit", page 17](#)).
4. Switch off the On/Off switch of the analyzer (position: top right in analyzer top part, see ["Analyzer", page 18](#)).
5. Check that the analyzer is free from voltage: All LEDs of the display must be OFF.
6. Unscrew and fold open the enclosure door of the analyzer bottom part.
7. RJ45 plug (network): Press on the lock and pull off.
8. 24 V plug: Press on the lock and pull off.
9. Unscrew the gas inlet and gas outlet.
10. Unscrew 3 screws (1 screw under the insulating cover) on the base plate.
11. Unscrew the grounding conductor on the module.
12. Take the FINOR module out.

Fitting

1. Screw the grounding conductor to the module.
2. Set the FINOR module (with insulating cover) on the base plate. The electric connections point to the left.
3. Screw 3 screws to the base plate.
4. Connect the gas inlet and gas outlet.
The lines are at the correct positions.
5. Connect the RJ45 plug.
6. Connect the 24 V plug (protected against twisting).
Note: When you have installed several modules: The positions of the RJ45 plugs and 24 V plugs are optional.
7. Test the gas tightness (see ["Leak tightness check", page 73](#)).
8. Close the enclosure door of the analyzer bottom part again.
9. Switch the On/Off switch on again.
10. Close the enclosure door of the analyzer top part again.
11. Switch fuse FC8 on again.
12. Close the enclosure door of the distribution unit again.
13. Set the stand-by switch to “OFF” again: see ["Switching on", page 21](#).

8.14 Replacing the O₂ module (OXOR E)

Figure 34: OXOR E module

- ① OXOR E
- ② 24 V plug
- ③ Grub screw

The OXOR E module (measurement of O₂) is in the analyzer bottom part.

Removing

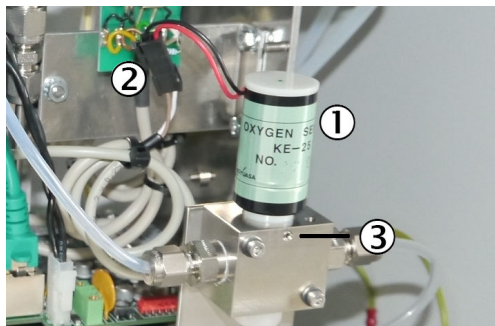
1. Set the Stand-by switch on the distribution unit to “ON” and wait for the sample gas flow to stop: (see ["Stand-by and switching off", page 94](#)).
2. Wait for 1 minute (sample gas path being flushed).
3. Switch off fuse FC8 (analyzer) (see ["Distribution unit", page 17](#)).
4. Switch off the On/Off switch of the analyzer (position: top right in analyzer top part, see ["Analyzer", page 18](#)).
5. Check that the analyzer is free from voltage: All LEDs of the display must be OFF.
6. Unscrew and fold open the enclosure door of the analyzer bottom part.
7. 24 V plug: Press on the lock and pull off.
8. Loosen the grub screw on the OXOR-E module.
9. Turn the OXOR E module lightly and pull out upwards.

Fitting

1. Place on the OXOR-E module. Ensure gas tightness (clean seal).
2. Screw in the grub screw lightly.
3. Connect the 24 V plug (protected against twisting).
4. Switch the On/Off switch on again.
5. Close the enclosure door of the analyzer top part again.
6. Switch fuse FC8 on again.
7. Close the enclosure door of the distribution unit again.
8. Set the stand-by switch to “OFF” again: see ["Switching on", page 21](#).
9. Adjust the zero point and span point: see ["Adjustment/validation of several components \(group function\)", page 44](#).

8.15 Replacing the gas module

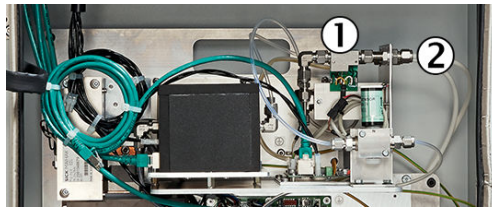

Figure 35: Gas module

- ① Gas module
- ② 2 Gas connections

The gas module (measurement of flow, humidity and pressure) is in the analyzer bottom part.

Removing

1. Remove the complete analyzer module: [see "Removing and fitting the complete analyzer module", page 92.](#)
2. Mark and unscrew 2 gas connections from the gas module.
3. 24 V plug: Press on the lock and pull off.
4. Unscrew 4 screws of the gas module at the bottom of the analyzer module.
5. Take the gas module off.

Fitting

1. Screw the gas module onto the complete analyzer module.
2. Connect the sample gas inlet according to the marking made.
3. Connect the 24 V plug (protected against twisting).
4. Connect the gas outlet according to the marking made.
5. Reinstall the complete analyzer module: [see "Removing and fitting the complete analyzer module", page 92.](#)

8.16 Removing and fitting the complete analyzer module

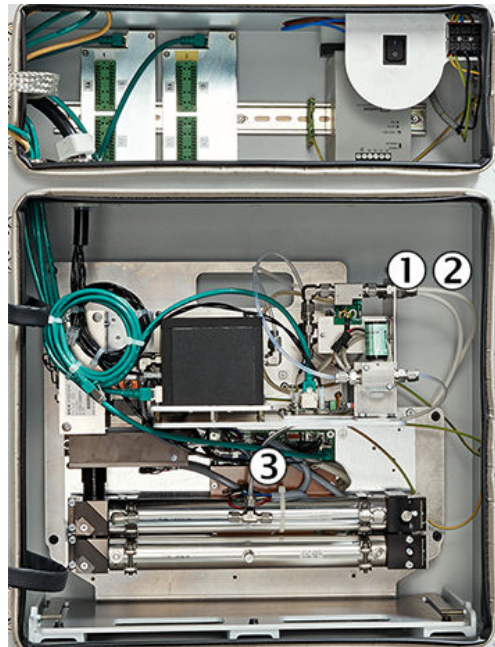

- ① Sample gas inlet (rear)
- ② Sample gas outlet (front)
- ③ Complete analyzer module

The complete analyzer module contains all measuring modules.

It is in the analyzer bottom part.

It can be removed complete with all modules.

Removing

1. Set the Stand-by switch on the distribution unit to “ON” and wait for the sample gas flow to stop: (see ["Stand-by and switching off", page 94](#)).
2. Wait for 1 minute (sample gas path being flushed).
3. Switch off fuse FC8 (analyzer) (see ["Distribution unit", page 17](#)).
4. Switch off the On/Off switch of the analyzer (position: top right in analyzer top part, see ["Analyzer", page 18](#)).
5. Check that the analyzer is free from voltage: All LEDs of the display must be OFF.
6. Unscrew and fold open the enclosure door of the analyzer bottom part.
7. Unscrew the grounding conductors on the side panel.
8. Mark and unscrew the sample gas inlet and gas outlet at the connections of the complete analyzer module.
9. Three RJ45 plugs (network): Press on the lock and pull off.
10. Three 24 V plugs: Press on the lock and pull off.
11. Unscrew 7 black screws from the base plate.
12. Pull the complete analyzer module by the grip handles to the front and lift out.

Fitting

1. Push the complete analyzer module in the enclosure. Make sure not to crimp any lines.
2. Screw 7 black screws tight.
3. Screw the grounding conductor to the side panel.
4. Plug on the 3 x RJ45 plugs (optional positions).

5. Plug on the 3 x RJ45 plugs (optional positions, protected against twisting).
 6. Connect the sample gas inlet (rear) according to the marking made.
 7. Connect the gas outlet (front).
 8. Check the gas tightness of the sample gas path: [see "Leak tightness check", page 73](#).
-
1. Set the Stand-by switch on the distribution unit to "ON" and wait for the sample gas flow to stop: ([see "Stand-by and switching off", page 94](#)).
 2. Wait for 1 minute (sample gas path being flushed).
 3. Switch off fuse FC8 (analyzer) ([see "Distribution unit", page 17](#)).
 4. Switch off the On/Off switch of the analyzer (position: top right in analyzer top part, [see "Analyzer", page 18](#)).
 5. Check that the analyzer is free from voltage: All LEDs of the display must be OFF.
 6. Switch the On/Off switch on again.
 7. Close the enclosure door of the analyzer top part again.
 8. Switch fuse FC8 on again.
 9. Close the enclosure door of the distribution unit again.
 10. Set the stand-by switch to "OFF" again: [see "Switching on", page 21](#).

9 Decommissioning

9.1 Stand-by and switching off



Figure 36: Switches at distributor unit

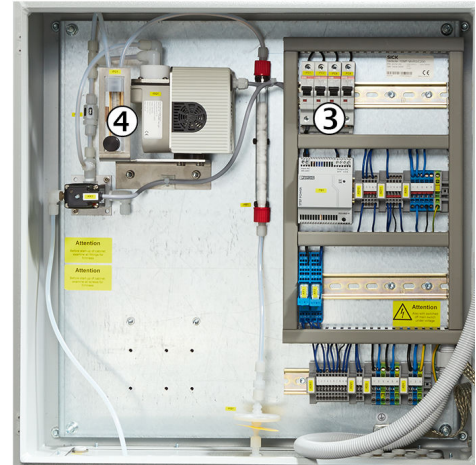

Figure 37: Fuses in distributor unit

- ① Main switch
- ② Stand-by switch
- ③ Fuses
- ④ Flowmeter



CAUTION

When switched off prematurely, there is a risk of contamination by sample gases remaining in the sample gas path.

- ▶ Follow the switch-off procedure described below and do not completely switch the system off immediately.

Switch the system to “Stand-by”

1. Set the Stand-by switch on the distribution unit to “ON” (see ["Distribution unit", page 17](#)).
 - ✓ The system is flushed with instrument air.
 2. Wait approx. 10 minutes for the sample gas flow to stop: The flowmeter in the distribution unit no longer shows a flow.
 - ✓ The heaters remain on and the sampling tube of the sampling probe is continued to be flushed with instrument air.
- You can now leave the measuring system in this state for as long as required.

Switching the system off completely (disconnect from the power supply)

The electric voltage (and thereby the heaters) is switched off in the following steps.

3. Switch off all fuses in the distribution unit.
4. Set the main switch on the distribution unit to “OFF”.
- ✓ The system is now switched off and the sampling tube is continued to be flushed with instrument air.

**CAUTION**

When the instrument air is switched off, there is the risk of contamination of the sampling tube

- ▶ Do not switch the instrument air off when the sampling tube is in the exhaust duct.

9.2 Protective measures for long-term storage

- When gas lines were unscrewed: Close all gas connections (with sealing plugs, if need be with adhesive tape) to protect internal gas paths against moisture, dust or dirt penetrating.

**NOTE**

The service life of the OXOR-E analyzer module will be reduced by contact to oxygen in the air even when the device is switched off.

- Cover open electrical connections dust-tight, e.g., with adhesive tape.
- Protect the control unit against sharp-edged objects. If necessary, cover the instrument with protective material (e.g., cardboard, styrofoam).
- Whenever possible, select a dry, well-ventilated room for storage.
- Pack the device (e.g., in a plastic sack).
- If high air humidity can be expected: Enclose a drying agent (e.g., silica gel) in the packing.

9.3 Shipping for repair

When the device is to be sent to the manufacturer or a Service company for repairs:

Please enclose the following information so that the device can be repaired as quickly as possible:

- An error description, as precise as possible (meaningful keywords suffice).
- For unclear functional problems: A short description of the operating conditions and installations (connected devices etc.).
- If shipping has been agreed with the manufacturer: The contact person at the manufacturer's who is informed about the matter.
- A contact person from the user's company (for possible questions).

**NOTE**

Please add the information even if your matter has already been discussed in detail with a manufacturer's employee.

9.4 Transport

- Protect the enclosure before transport: [see "Protective measures for long-term storage", page 95](#).
- Use the original packaging for transport whenever possible alternatively a suitable padded stable packaging.
- A transport container with adequate stability can also be used.
Protect the device with padding from shocks and vibrations, and thoroughly secure the device in place inside the transport container.
Ensure adequate clearance from the walls of the transport container.

**NOTE**

Accompanying documents when shipping for repairs: [see "Shipping for repair", page 95](#).

9.5 Disposal

The device can easily be disassembled into its components which can then be sent to the respective raw material recycling facilities.



NOTE

The following subassemblies contain substances that may have to be disposed of separately:

- Electronics: Capacitors, rechargeable batteries, batteries.
 - Display: Liquid of LC display.
 - Sample gas filter: Sample gas filters could be contaminated by pollutants.
 - All lines with sample gas contact could be contaminated with pollutants.
-

10 Technical data



NOTE

The technical data depend to some extent on the individual equipment of your device.

- ▶ See the enclosed System Description for the configuration of your device.

10.1 Dimensional drawings

10.1.1 Dimensional drawing of sample conditioning

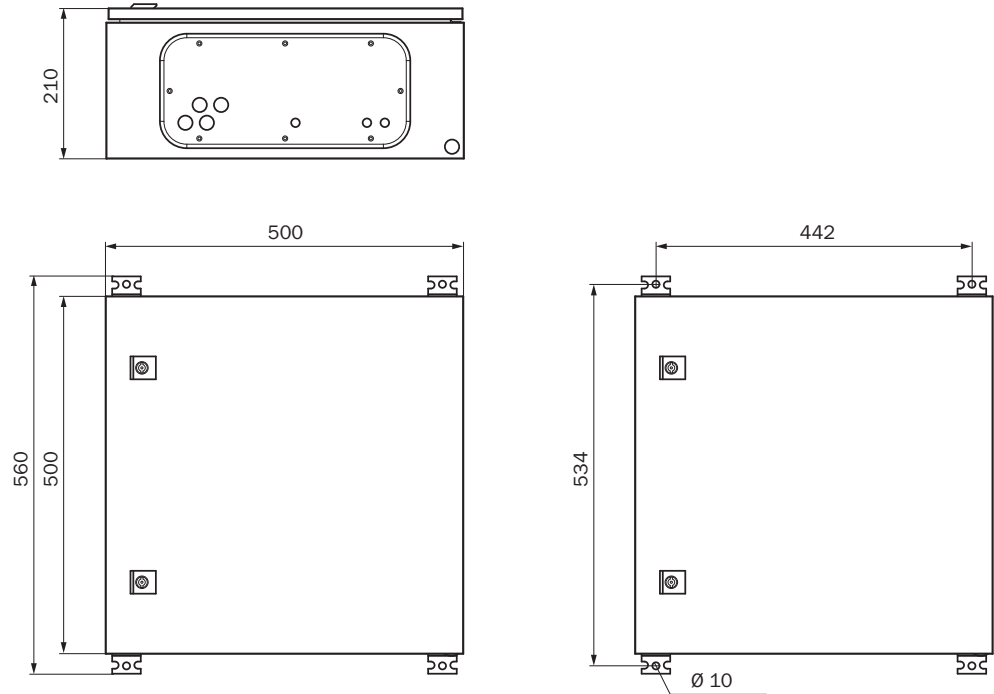

NOTICE

Observe clearances:

- Bottom: 20 cm
- Right: 30 cm

10.1.2 Dimensional drawing of distribution unit

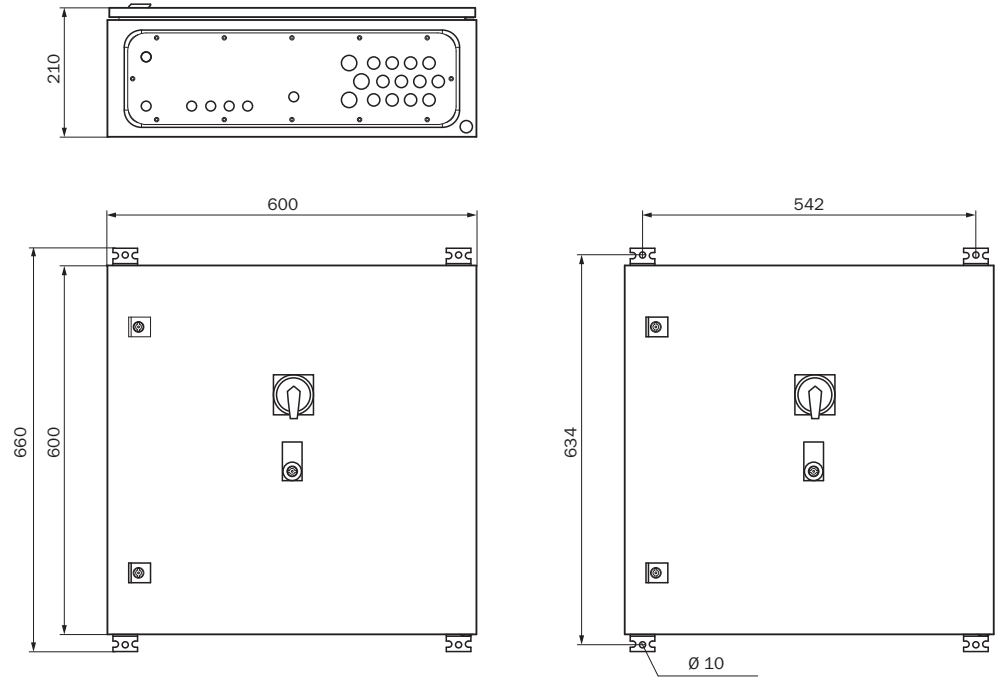

NOTICE

Observe clearance:

- Bottom: 20 cm

10.1.3 Dimensional drawing of analyzer

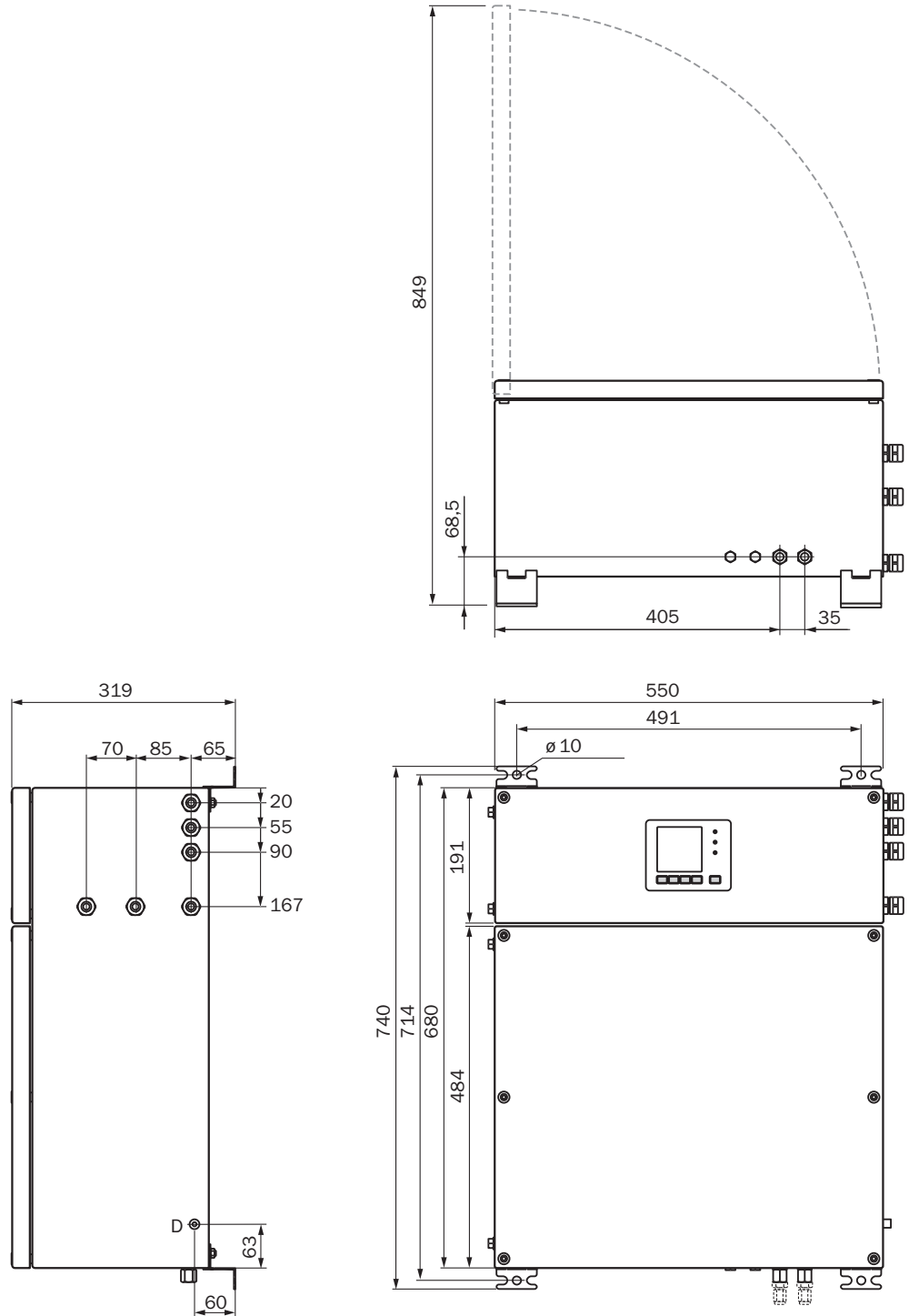

NOTICE

Observe clearance:

- Right: 10 cm
- Bottom: 20 cm

10.1.4 Dimensional drawing of sampling probe

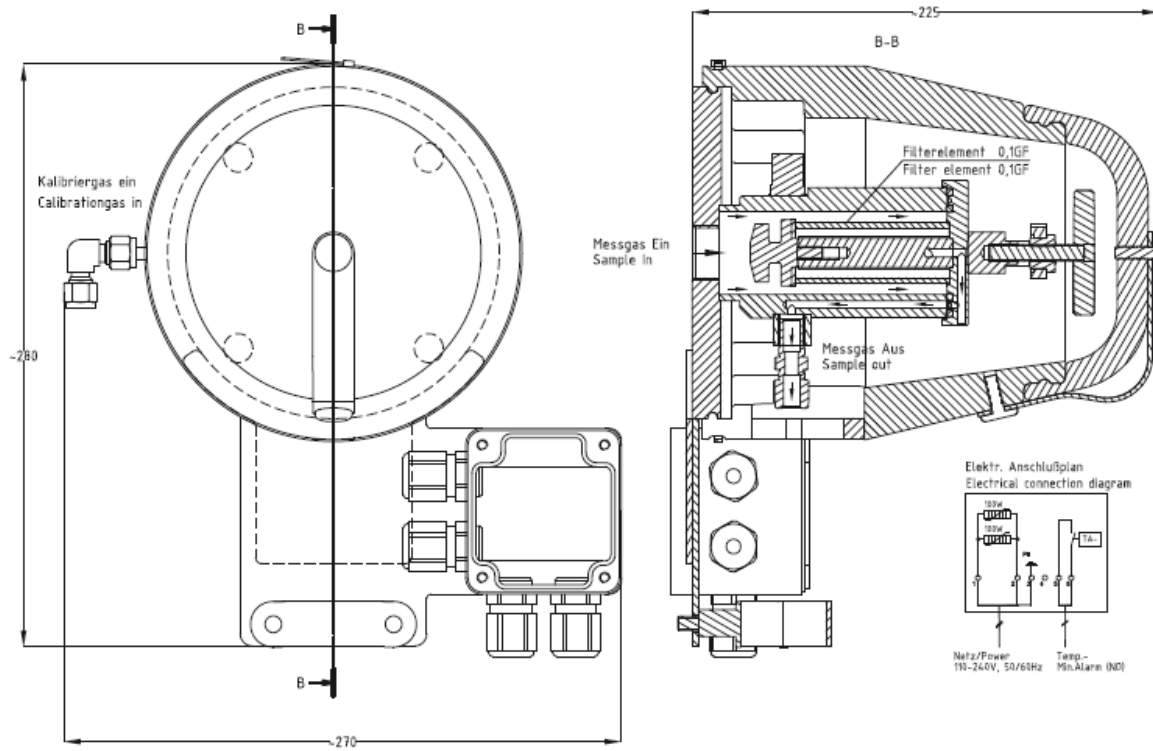

Probe tube length	Part number
400	5329476
600	5329477
800	5329478

10.1.5 Sample gas line, heated

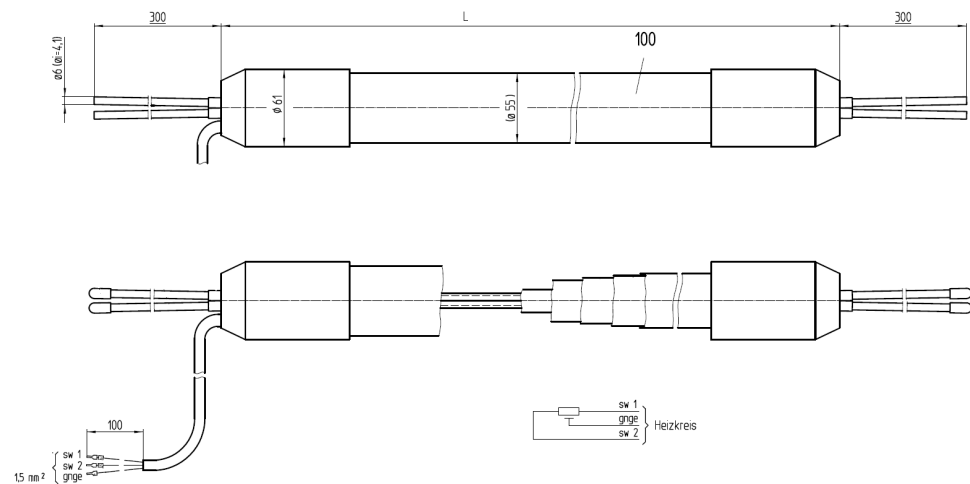

Figure 38: Technical drawing - heated sample gas line

10.2 Gas flow diagram

SINGLE version distribution unit for one measuring point

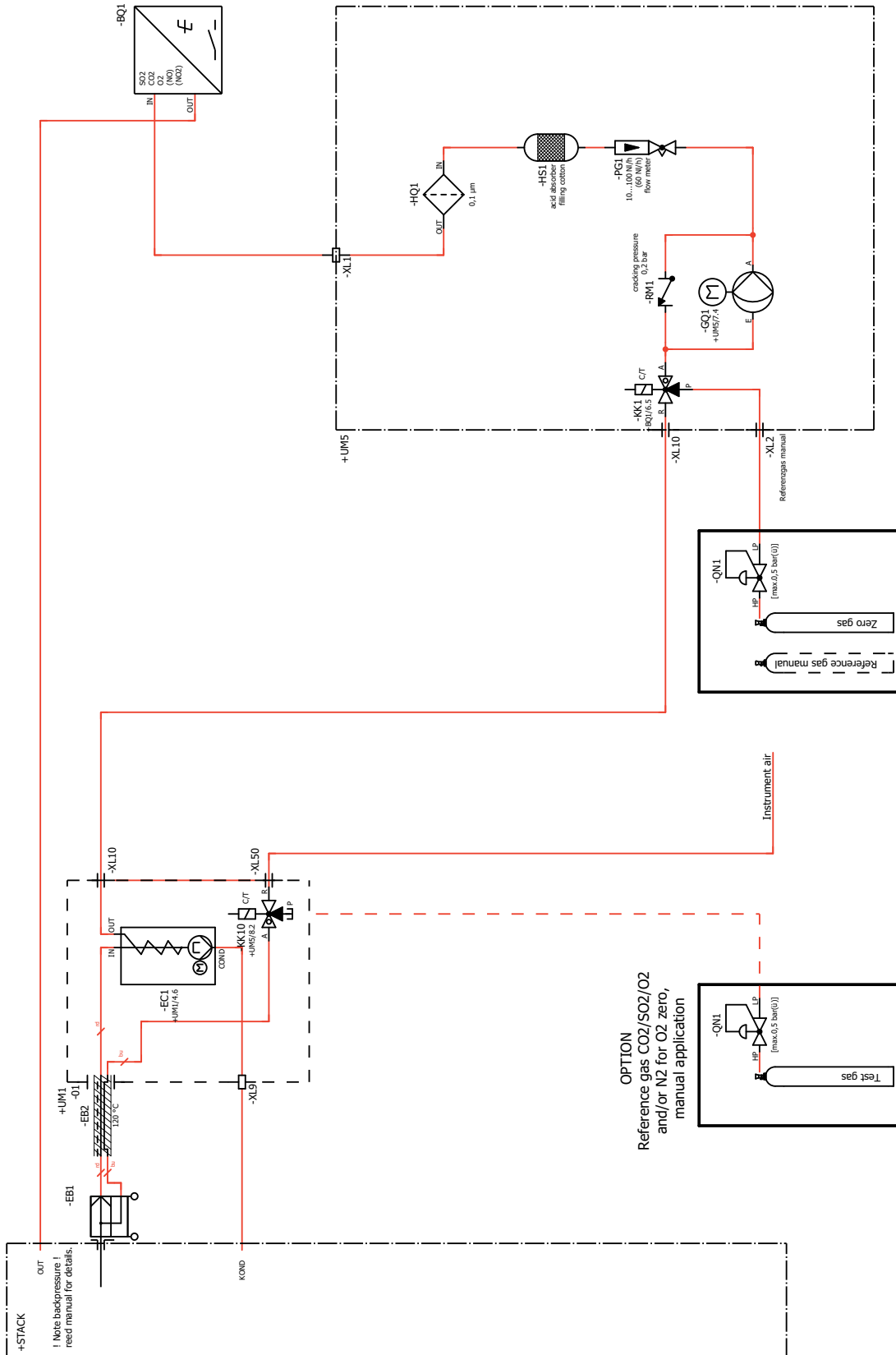

Figure 39: Gas flow diagram

MULTI version distribution unit for two to four measuring points

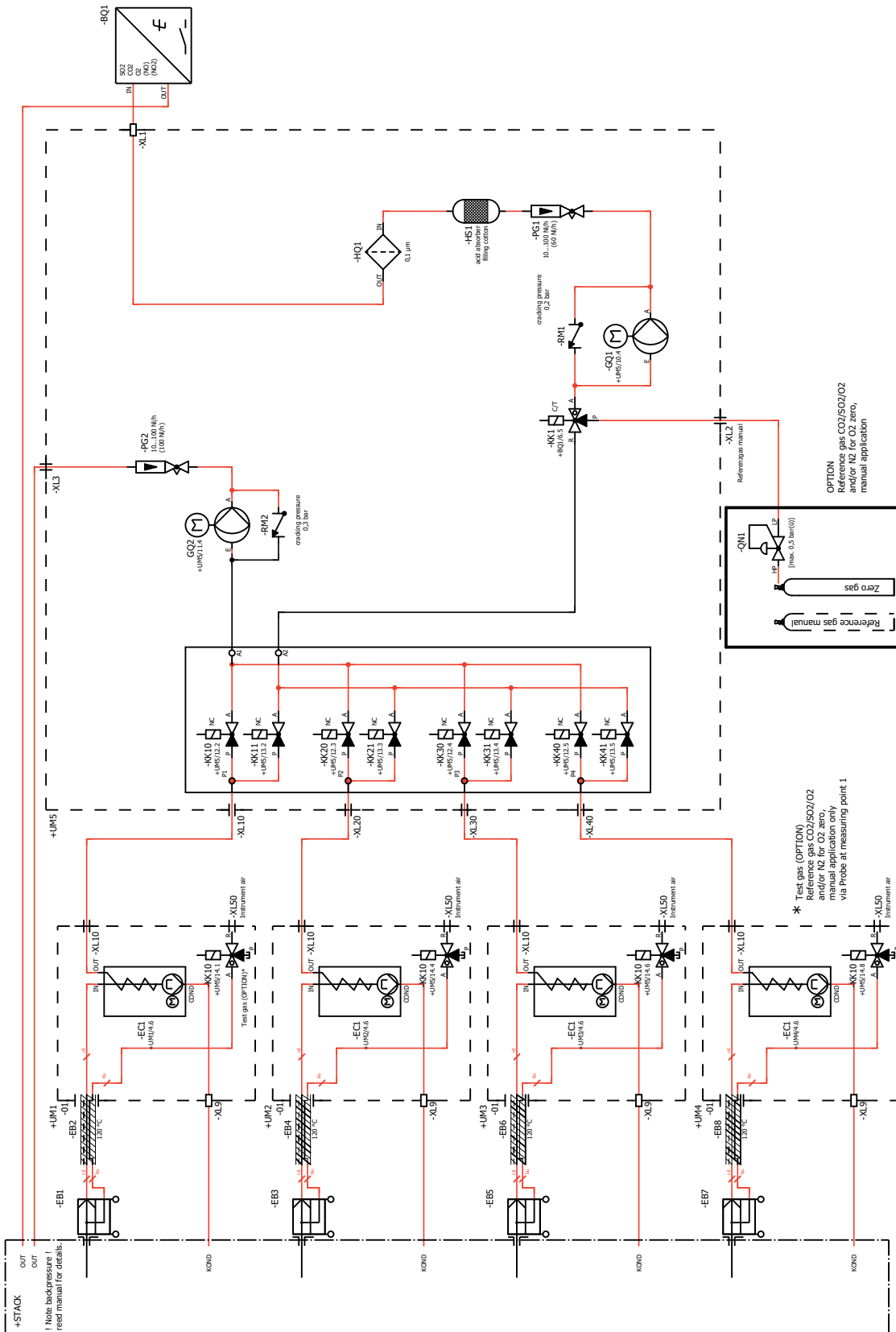

Figure 40: Gas flow diagram

10.3 Measuring parameters

Variant	Components
DeSO _x	SO ₂ , CO ₂ , optional O ₂
Full configuration	SO ₂ , CO ₂ , NO, NO ₂ , optional O ₂

Number of measured variables	
Number of measured variables	Max. 5

Measuring method	
Measuring method	Cold-extractive

Sample volume	
Sample volume	60 ... 100 l/h

Spectral range	
Spectral range	UV, VIS

Component	Measuring ranges
SO ₂	0 ... 100 ppm; 0 ... 500 ppm
CO ₂	0 ... 25% by volume
O ₂	0 ... 21%volume
NO	0 ... 300 ppm; 0 ... 1500 ppm
NO ₂	0 ... 200 ppm; 0 ... 500 ppm

Measuring point switchover	
Measuring point switchover	Max. 4 measuring points

Measured value characteristics	
Measuring precision	< 1% of the respective full scale value
Detection limit	< 0.5% of the respective full scale value
Sensitivity drift	< 2% of the respective full scale value per week
Zero drift	< 2% of the respective full scale value per week
Span drift	< 2% of the respective full scale value per week
Setting time t ₉₀	15 ... 30 s, total active measuring path as from sampling (With advance extraction with several measuring points)

10.4 Ambient conditions

Ambient conditions in operation	
Installation location	Below deck
Ambient temperature	+5 ... +45 °C
Relative humidity	< 90% (without condensate)
Air pressure	900 ... 1100 hPa
Degree of protection	IP 54

Ambient conditions in storage	
Ambient temperature	-20 ... +70 °C
Relative humidity	< 90% (without condensate)

10.5 Sample gas conditions

Sample gas at the measuring point	Characteristics
Process temperature	10 ... 550 °C
Sample gas temperature	200 °C
Process pressure	-90 ... +200 hPa relative
Dust load	< 200 mg/m ³

10.6 Design as wall enclosure

Sampling probe	
Ambient temperature	-25 ... 65 °C
Working temperature	+180 °C, self-regulating
Filter element	Fine filter 0.1 µm
Power supply	115 V / 230 V
Power consumption	Start: 400 VA, operation: 100 VA
Degree of protection	IP 54
Weight	Approx. 7.5 kg
Dimensions	see "Dimensional drawing of sampling probe", page 100

Design as wall enclosure	
Design	3 x wall enclosure <ul style="list-style-type: none"> • Sample conditioning • Distribution unit • Analyzer
Material, general	Steel plate according to EN 10130
Dimensions	see "Dimensional drawings", page 97
Installation	Wall fitting
Weight	<ul style="list-style-type: none"> • Sample conditioning: Approx. 27 kg • Distribution unit: Approx. 30 kg • Analyzer: Approx. 37 kg
Materials with media contact	<ul style="list-style-type: none"> • PTFE • Viton B • PVDF • Stainless steel 1.4571 • Platinum, nickel • Aluminum • CaF₂
Degree of protection	<ul style="list-style-type: none"> • Sample conditioning: IP54 • Distribution unit: IP54 • Analyzer: IP54

10.7 Sample gas line, heated

Sample gas line	
Ambient temperature	-20 ... 80 °C
Working temperature	+120 °C
Heating	Self-regulating parallel heater line
Power supply	115 V / 230 V
Power consumption	60 W/m at 10 °C
Dimensions	see "Sample gas line, heated", page 100
Degree of protection	IP 54
Protection class	I

10.8 Interfaces and protocols

Operation and interfaces	
Operation	Via LC-Display or SOPAS ET software, several operating levels, password-protected
Display and input	Black-and-white foiled screen with function buttons Status LEDs: <ul style="list-style-type: none"> • "Power" • "Malfunction" • "Maintenance request"
Remote control	Ethernet (TCP/IP): <ul style="list-style-type: none"> • Connector: RJ 45 • Type: TCP/IP Peer-to-Peer. • Method: 10 MBit half-duplex Modbus
Remote maintenance	SICK MPR (optional)
PC operation	SOPAS ET via Ethernet

Analog outputs	
Number	8
Reference potential	Potential-free (electrically isolated)
Signal range	0 ... 24 mA
Residual ripple	0.02 mA
Resolution/precision	0.1% (20 µA)
Accuracy	0.25% of full-scale value
Maximum load	500 Ω
Maximum output voltage	15 V
Start or error state	Adjustable

Analog inputs	
Number	2
Reference potential	GND
Input signal	0 ... 20 mA
Highest allowable input signal	30 mA
Overcurrent protective device	±1000 mA

Analog inputs	
Input load	50 Ω
Transducer precision	0,5 %

Digital inputs	
Design	Optical coupler
Number	8
Switching range	18 ... 42 V
Highest allowable voltage	± 50 V DC

Digital outputs	
Number	16
Contact type:	1-pole changeover switch, 3 connections
Contact load:	See Table below
Highest allowable voltage	± 50 V DC

Table 6: Maximum load per relay switching contact

Application area		AC voltage	DC voltage	Current
Standard:		Max. 30 VAC	Max. 48 VAC	Max. 500 mA
CSA	Either	Max. 30 VAC	Max. 48 VAC	Max. 50 mA
	or	Max. 15 VAC	Max. 24 VAC	Max. 200 mA
	or	Max. 12 VAC	Max. 18 VAC	Max. 500 mA

**NOTICE**

Only use discharging diodes to connect inductive loads (e.g., relays, solenoid valves) to the switching outputs.

- For inductive loads: Check that discharging diodes are fitted.
- If this is not the case: Install external discharging diodes.

10.9 Energy supply

Power supply	
Supply voltage	115/230 VAC, 50/60 Hz Deviating power supply via upstream transformer
Current	8 A (with 230 V)
Power consumption	Power consumption
<ul style="list-style-type: none"> • Sampling probe • Sample gas line • Sample conditioning • Distribution unit • Analyzer 	<ul style="list-style-type: none"> • 400 VA • 60 VA/m • 150 VA • 200 VA (1 MPI), 300 VA (2 ... 4 MPI) • 300 VA

Power input, complete system (max. for each 5 m sample gas line)			
Number of measuring points	Power consumption	Current (230 VAC)	Current (115 VAC)
1	1400 VA	6 A	12 A
2	2300 VA	10 A	20 A
3	3200 VA	14 A	28 A

Power input, complete system (max. for each 5 m sample gas line)			
4	4000 VA	17 A	35 A

Connections	
Connections, analyzer	<ul style="list-style-type: none"> Signal cable, 7-wire, 1.5 mm², shielded, e.g., Marineline (Sick Part No. 6056230) Power cable, 3-wire, min. 1.5 mm², e.g., Marineline (Sick Part No. 6056215)
Distribution unit	<ul style="list-style-type: none"> Signal cable, 7-wire, 1.5 mm², shielded, e.g., Marineline (Sick Part No. 6056230) Signal cable, 4-wire, 0.75 mm², shielded, e.g., Marineline (Sick Part No. 6056229) Power cable, 3-wire, min. 1.5 mm², e.g., Marineline (Sick Part No. 6056215)
Sample conditioning	<ul style="list-style-type: none"> Signal cable, 4-wire, 0.75 mm², shielded, e.g., Marineline (Sick Part No. 6056229) Power cable, 3-wire, min. 1.5 mm², e.g., Marineline (Sick Part No. 6056215)
Sample gas line	<ul style="list-style-type: none"> Power cable, 3-wire, 1.5 mm²
Sampling probe	<ul style="list-style-type: none"> Signal cable, 4-wire, 0.75 mm², shielded, e.g., Marineline (Sick Part No. 6056229) Power cable, 3-wire, min. 1.5 mm², e.g., Marineline (Sick Part No. 6056215)

10.10 Emissions

Emissions	
Condensate	For water vapour-saturated exhaust gas (e.g., after exhaust gas washer): Approx. 2 liters of condensate per week

10.11 Torques for screw fittings

A medium total friction coefficient of $\mu=0.12$ is assumed in the specification of torques. This means that the screws are installed lightly oiled.

Analyzer	Property class	Torque
Analyzer door screw fitting	A2-50	3 Nm
Analyzer enclosure 4 screws M8 bolts and bracket on analyzer enclosure	8.8	23.1 Nm
	10.9	34 Nm
	12.9	39.6 Nm
	A2/4-50	7.1 Nm
	A2/4-70	16 Nm
A2/4-80:9	22 Nm	
FINOR 3 screws base plate		4 Nm
Ground screw FINOR		3 Nm
Ground screw analyzer		3 Nm
Gas module 4 screws base plate		3 Nm
Complete analyzer module, 7 black screws		9 Nm

Sample conditioning and distribution unit	Torque
Insertion of sample gas line 2 clamping screws	1.5 Nm
Insertion of sample gas line 4 frame screws	1.5 Nm
Solenoid valve M4	2 Nm
Cover of solenoid valve M2.5	0.35 Nm
Pump M4	2 Nm
Sample gas cooler M6	6 Nm
Enclosure, complete	See above "Analyzer"

10.12 Tube connections

Connection	Dimension
Sample gas connections	Swagelok DN 4/6
Instrument air	Hose coupling DN 4/6
Test gas	Hose coupling DN 4/6

10.13 Sample gas conditions



NOTICE

Risk of contamination of analyzer

- ▶ Observe the specified quality of the instrument air
- ▶ If required, provide for instrument air conditioning

Gas	Quality	Inlet pressure	Flow rate
Instrument air	Particle size max. 1 μm Oil content max. 0.1 mg/m ³	Max. +300 hPa	Typically 60 l/h
Zero point gas	Nitrogen 5.0	Max. +300 hPa	Typically 60 l/h
Span gas	External span gas Precision: $\pm 2\%$ Concentration: 80% ... 100% of measuring range The span gas must comply with the specifications of the standards to be applied (e.g., MARPOL Annex VI)	Max. +300 hPa	Typically 60 l/h

11 Annex

11.1 Logbook messages

11.1.1 Measured value assignment (MVx) (example)

Meas. value	Component	Module	Remark
MV1	SO2	DEFOR	
MV2	NO2	DEFOR	
MV3	CO2	FINOR	
MV5	Pressure	Gas module	Auxiliary value
MV6	O2	Gas module	Auxiliary value
MV7	Flow	Gas module	Auxiliary value
MV8	Ratio	DEFOR+FINOR	

11.1.2 Logbook messages

		Logbook text (Display)	Logbook text (SOPAS ET)	Description	Interpretation and possibly correction	
Gas module						
I		DEFOR				
I	I	FINOR				
X	X	X	F MV calculation	F MV calculation	Error in calculation of measured value; measured value > +50% of measurement span.	Gas concentration too high, component settings changed, check sensor system adjustment
X	X	X	F zero drift	F zero drift	Zero drift limit value exceeded by more than 20%	Check test gas, check setpoint value; check measuring system
X	X	X	F span drift	F span drift	Span drift limit value exceeded by more than 20%	Check test gas, check setpoint value; check measuring system
X	X	X	U MV overflow	U MV overflow	Measuring range exceeded by more than 20% of measurement span	Gas concentration too high, component settings changed, check sensor system adjustment
X	X	X	U ADC value	U ADC value	Overmodulation of measuring signal, no resolution possible	Gas concentration too high, detector damaged, optical active measuring path contaminated or mechanically misadjusted
	X	X	U pressure value absent	U pressure value absent	InProcessValue pressure not received	Gas module available? Pressure component available on gas module? Pressure in auxiliary value table of BCU?
	X	X	M pressure value absent	M pressure value absent	InProcessValue pressure not received	Gas module available? Pressure component available on gas module? Pressure in auxiliary value table of BCU?
X	X	X	M zero drift	M zero drift	Zero drift limit value was exceeded	Check test gas, check setpoint value; check measuring system
X	X	X	M span drift	M span drift	Span drift limit value was exceeded	Check test gas, check setpoint value; check measuring system
X	X	X	M zero gas	M zero gas	Zero point adjustment not saved; drift limit value exceeded by > 50%	Check test gas, check setpoint value; check measuring system
X	X	X	M span gas	M span gas	Span point adjustment not saved; drift limit value exceeded by > 50%	Check test gas, check setpoint value; check measuring system
X	X	X	C test gas active	C test gas active	Test gas is in system	At least one component in the system is being adjusted/validated
X	X	X	C adj/val	C adj/val	Validation or adjustment activated, sensor or system is checked	Status message, wait until the procedure has completed
	X	X	E no A/D reference	E no A/D reference / E no IR reference	No zero gas AD reference values	Replace the complete analyzer module
	X	X	U pressure value FCU	U pressure value FCU	InProcessValue pressure has F, C and/or U flag	Check pressure component of gas module, observe further gas module messages

		Logbook text (Display)	Logbook text (SOPAS ET)	Description	Interpretation and possibly correction
	X	F motor 1	F motor 1	DEFOR: Initialization of motor 1 incorrect	Restart device. If error is repeated, replace complete analyzer module
	X	F motor 2	F motor 2	DEFOR: Initialization of motor 2 incorrect	Restart device. If error is repeated, replace complete analyzer module
	X	F motor 3	F motor 3	DEFOR: Initialization of motor 3 incorrect	Restart device. If error is repeated, replace complete analyzer module
X	X	F measuring detector	F measuring detector	DEFOR: Error message from measured value detector	Restart device. If error is repeated, replace complete analyzer module
	X	F reference detector	F reference detector	DEFOR: Error message from reference value detector	Restart device. If error is repeated, replace complete analyzer module
	X	F position motor 1	F position motor 1	Motor 1 position error	Restart device. If error is repeated, replace complete analyzer module
	X	F position motor 2	F position motor 2	Motor 2 position error	Restart device. If error is repeated, replace complete analyzer module
	X	F position motor 3	F position motor 3	Motor 3 position error	Restart device. If error is repeated, replace complete analyzer module
	X	M extraneous light	M extraneous light	Extraneous light has penetrated the measuring system	Device open, extraneous light has penetrated the measuring system
	X	M mirror	M mirror	Mirror error	Restart device. If error is repeated, replace complete analyzer module
	X	M beam splitter	M beam splitter	Beam splitter error	Restart device. If error is repeated, replace complete analyzer module
	X	M filter	M filter	Filter error	Restart device. If error is repeated, replace complete analyzer module
	X	X M UV source intensity / M IR intensity	M UV source intensity / M IR intensity	Source intensity below maintenance request threshold	Replace the complete analyzer module
X	X	X C Maintenance mode	C maintenance active	Maintenance active	Status message, check active, maintenance active
X	X	X C start check	C Start check	Start check	Function checks active after switching on
X	X	X U Maintenance mode	U maintenance active	Maintenance active	Maintenance active, measured values unreliable, no action required
X	X	X U start check	U start check	Start check	Function checks active after switching on, no action required
	X	U extraneous light	U extraneous light	Extraneous light has penetrated the measuring system	Measured value unreliable, device open, extraneous light has penetrated the measuring system
	X	U mirror	U mirror	Mirror error	Restart device. If error is repeated, replace complete analyzer module
	X	U beam splitter	U beam splitter	Beam splitter error	Restart device. If error is repeated, replace complete analyzer module
	X	U filter	U filter	Filter error	Restart device. If error is repeated, replace complete analyzer module
	X	X U UV source intensity / U IR intensity	U UV source intensity / U IR intensity	Source intensity below uncertain threshold	Restart device. If error is repeated, replace complete analyzer module
	X	U position motor 1	U position motor 1	Motor 1 position error	Motor 1 has not found the zero position. Restart device. If error is repeated, replace complete analyzer module
	X	U position motor 2	U position motor 2	Motor 2 position error	Motor 2 has not found the zero position. Restart device. If error is repeated, replace complete analyzer module
	X	U position motor 3	U position motor 3	Motor 3 position error	Motor 3 has not found the zero position. Restart device. If error is repeated, replace complete analyzer module
X	X	X U temperatures	U temperatures	Mainboard temperature >75 °C and/or heater(s) not in nominal range	Temperature on electronics too high, defective heaters, check further logbook messages

		Logbook text (Display)	Logbook text (SOPAS ET)	Description	Interpretation and possibly correction
	X	E motor 1 temperature	E motor 1 temperature	Temperature of motor control 1 too high	Replace the complete analyzer module
	X	E motor 2 temperature	E motor 2 temperature	Temperature of motor control 2 too high	Replace the complete analyzer module
	X	E motor 3 temperature	E motor 3 temperature	Temperature of motor control 3 too high	Replace the complete analyzer module
	X	E motor 1 V reduced	E motor 1 V reduced	Speed of motor 1 reduced	For information only
	X	E motor 2 V reduced	E motor 2 V reduced	Speed of motor 2 reduced	For information only
	X	E motor 3 V reduced	E motor 3 V reduced	Speed of motor 2 reduced	For information only
X	X	X	no entry (E adj/val)	At least one component in the system is being adjusted/validated	Test gas is in gas path. No action required, wait until the procedure has completed
X		E gas pump	E gas pump	Status of sample gas pump	Status of sample gas pump
X	X	X	E gas pump off	Switch off request from gas pump sensor	Status message, switch off request from gas pump sensor. Check further logbook messages
X		E gas flow low	E gas flow low	Message: Gas low below threshold	Check sample gas paths for clogging, check pump and replace, as required
X		E gas flow error	E gas flow error	Message: Gas flow more than 20% below threshold	Check sample gas paths for clogging, check pump and replace, as required
X		F humidity signal	F humidity signal	Threshold for humidity detection exceeded	Device switches off because of humidity detected in the gas path. Service required for drying
	X	E detector synchronization	E detector synchronization	Error during synchronised AD conversion	Error in program sequence, restart device. If error is repeated, replace complete analyzer module
X	X	F heater 1	F heater 1	Heater 1: Sensor or power control defective	Ambient temperature outside specification or sensor module is defective and must be replaced.
X		F heater 2	F heater 2	Heater 2: Sensor or power control defective	Ambient temperature outside specification or sensor module is defective and must be replaced.
X		F heater 3	F heater 3	Heater 3: Sensor or power control defective	Ambient temperature outside specification or sensor module is defective and must be replaced.
X		F heater 4	F heater 4	Heater 4: Sensor or power control defective	Ambient temperature outside specification or sensor module is defective and must be replaced.
X		F heater 5	F heater 5	Heater 5: Sensor or power control defective	Ambient temperature outside specification or sensor module is defective and must be replaced.
X	X	X	E SPI 1	Malfunction of SPI 1 data transmission	Malfunction in program sequence, no action possible. Restart device. If error is repeated, replace module
	X	X	E SPI 2	Malfunction of SPI 2 data transmission	Malfunction in program sequence, no action possible. Restart device. If error is repeated, replace module
	X		E I2C 1	Malfunction of I2C 1 data transmission	Malfunction in program sequence, no action possible. Restart device. If error is repeated, replace module
	X	X	E I2C 2	Malfunction of I2C 2 data transmission	Malfunction in program sequence, no action possible. Restart device. If error is repeated, replace module
X	X	X	E I2C 3	Malfunction of I2C 3 data transmission	Malfunction in program sequence, no action possible. Restart device. If error is repeated, replace module
X	X	X	F EEPROM	EEPROM malfunction	Malfunction in program sequence, no action possible. Restart device. If error is repeated, replace module
X	X	X	E LM75	Malfunction of LM75 (temperature measurement)	Malfunction in program sequence, no action possible. Restart device. If error is repeated, replace module
	X	X	F config. invalid	Error in configuration	Error when loading sensor parameters, restart device
	X	X	F program sequence	Error in program timing	Malfunction in program sequence, no action possible. Restart device. If error is repeated, replace module

		Logbook text (Display)	Logbook text (SOPAS ET)	Description	Interpretation and possibly correction	
X	X	X	F initialising	F start	Error in initialization	Malfunction in program sequence, no action possible. Restart device. If error is repeated, replace module
X	X	X	F loading config.	F loading config.	Error when loading a configuration	Error when loading sensor parameters, restart device
X	X	X	E CAN	E CAN	Error of CANBus	Malfunction in program sequence, no action possible. Restart device. If error is repeated, replace module
X	X	X	F UV source / U IR source	F UV source / U IR source	Error on UV lamp	Restart device. If error is repeated, replace complete analyzer module
X			F measuring detector	F measuring detector	Error message from measured value detector	Restart device. If error is repeated, replace complete analyzer module
X			F reference detector	F reference detector	Error message from reference value detector	Restart device. If error is repeated, replace complete analyzer module
X			M UV source aged	M UV source aged	Limit value of lamp aging reached	UV lamp must be replaced soon. Complete analyzer module must be replaced soon.
X			M contamination	M contamination	Measuring system contaminated	Check the filter. Restart device. If error is repeated, replace complete analyzer module
X	X	X	F UV source intensity / F IR intensity	F UV source intensity / F IR intensity	Source intensity below uncertain threshold	Replace the complete analyzer module
X	X	X	E backup factory settings	E backup factory settings	Backup of factory settings	Message only displayed when backup failed; repeat backup
X	X	X	E backup user settings	E backup user settings	Backup of user settings	Message only displayed when backup failed; repeat backup
X	X	X		no entry	Sensor received a signal from BCU that at least one component is adjusted/validated in the system	Test gas is in the system. No action required
X			E gains increased	E gains increased	ADC gains were increased due to lamp intensity losses	For information only

BCU

		(Display) English	(SOPAS) English		
		Configuration loading error	F Configuration loading error	An error was detected when the internal configuration was loaded	Can be performed after the firmware update. Perform a warm start. Memory defective when repeated. *2
		Memory allocation error	F Memory allocation error	Error determined during internal memory management.	No safe operation existing. Software overflow or memory error. Perform a warm start. *2
		Start check	C Start check	Start check. Check functions active after switching on	Check functions active for approx. 2 minutes after switching on
		Stack overflow	Stack overflow	Error in program management	No safe operation existing. Software overflow or memory error. *2
		TCP error A	TCP error A	Error on Ethernet interface	Error in Ethernet network, error in TCP protocol. Restart device. *2
		CAN error	CAN error	Error on CAN Open interface	Error in CAN protocol or network, check CAN wiring in device or system. *3
		IO module 1 lost	F IO module 1 lost	Connection to first IO module lost	Interruption of network connection to first IO module. Check internal network cables.
		IO module 2 lost	F IO module 2 lost	Connection to second IO module lost	Interruption of network connection to second IO module. Check internal network cables.
		Sensor meas. value error	Sensor meas. value error		Check further logbook entries.
		Sequence control program error	Sequence control program error	Sequence control program error	Check further logbook entries. Restart device. *2
		SPI 1 error	SPI 1 error	Error in communication in SPI channel 1	Contamination on PCB or defective hardware. *2
		SPI 2 error	SPI 2 error	Error in communication in SPI channel 2	Contamination on PCB or defective hardware. *2

	Logbook text (Display)	Logbook text (SOPAS ET)	Description	Interpretation and possibly correction
	I2C 1 error	I2C 1 error	Error in communication in I2C channel 1	Contamination on PCB or defective hardware. Restart device *2
	I2C 2 error	I2C 2 error	Error in communication in I2C channel 2	Contamination on PCB or defective hardware. Restart device *2
	I2C 3 error	I2C 3 error	Error in communication in I2C channel 3	Contamination on PCB or defective hardware. Restart device *2
	SD error	SD error	Error during writing or reading the SD card	If the error occurs several times, the SD card must be replaced. *2
	SD card defect	F SD card defective	SD card cannot be processed	Check correct installation of SD card. Replace SD card as required. *2
	LM75	LM75	Error message from temperature sensor IC	Contamination on PCB or defective hardware. *2
	Sensor lost	F Sensor lost	Error: Connection to DEFOR sensor lost	Check wiring to DEFOR sensor. Restart device. Replace the complete analyzer module as required
	Sensor lost	F Sensor lost	Error: Connection to FINOR sensor lost	Check wiring to FINOR sensor. Restart device. Replace the complete analyzer module as required
	Sensor lost	F Sensor lost	Error: Connection to gas module lost	Check wiring to gas module. Restart device. Replace the complete analyzer module as required
	Sensor	U Sensor	DEFOR sensor status uncertain	Check status messages at sensor and clear messages
	Sensor	U Sensor	FINOR sensor status uncertain	Check status messages at sensor and clear messages
	Sensor	U Sensor	Gas module status uncertain	Check status messages at sensor and clear messages
	Sensor registration error	Sensor registration error	Error during DEFOR sensor registration	Check sensor wiring. Restart device.
	Sensor registration error	Sensor registration error	Error during FINOR sensor registration	Check sensor wiring. Restart device.
	Sensor registration error	Sensor registration error	Error during gas module sensor registration	Check sensor wiring. Restart device.
	Sensor error A	Sensor error A	Error in data communication to DEFOR sensor	Check sensor wiring. Restart device.
	Sensor error A	Sensor error A	Error in data communication to FINOR sensor	Check sensor wiring. Restart device.
	Sensor error A	Sensor error A	Error in data communication to gas module	Check sensor wiring. Restart device.
	Sensor error B	Sensor error B	Error in data communication to DEFOR sensor	Check sensor wiring. Restart device.
	Sensor error B	Sensor error B	Error in data communication to FINOR sensor	Check sensor wiring. Restart device.
	Sensor error B	Sensor error B	Error in data communication to gas module	Check sensor wiring. Restart device.
	Sensor de-registration error	Sensor de-registration error	Error during registration of a module	Check sensor wiring. Restart device.
	Measuring screen	Measuring screen	Error in display parameters	Error in BCU configuration display parameters
	Tag: Formula	Tag: Formula	Error in formula interpreter	Error in BCU configuration in formula part
	Cyclic trigger	Cyclic trigger	Error in timer configuration	Error in BCU during timer configuration
	Adj./Val.	Adj./Val.	Error in adjustment/validation configuration	Error in BCU in adjustment/validation configuration
	Prod. settings backup failed	Prod. settings backup failed	Backup of production settings failed.	Error during data backup. Repeat data backup
	User settings backup failed	User settings backup failed	Backup of user settings failed.	Error during data backup. Repeat data backup
	Manual adjust	C Manual adjust	A manually started manual adjust is active	Status message. A manually started procedure for manual adjust is active.

	Logbook text (Display)	Logbook text (SOPAS ET)	Description	Interpretation and possibly correction
	Adj./Val.	C Adj./Val.	Automatic adjustment / validation is active	Status message. An automatic procedure for adjustment / validation is active.
	Sensor	F Sensor	Error message from DEFOR sensor module	Status messages. Check logbook messages.
	Sensor	F Sensor	Error message from FINOR sensor module	Status messages. Check logbook messages.
	Sensor	F Sensor	Error message from gas module	Status messages. Check logbook messages.
	Meas. value	F Meas. value	Status message for meas. value Failure	Status can be output by the sensor module or be generated in the BCU. Check logbooks.
	Meas. value	M Meas. value	Status message for meas. value Maintenance	Status can be output by the sensor module or be generated in the BCU. Check logbooks.
	Meas. value	C Meas. value	Status message for meas. value check	Status can be output by the sensor module or be generated in the BCU. Check logbooks.
	Meas. value	U Meas. value	Status message for meas. value Uncertain	Status can be output by the sensor module or be generated in the BCU. Check logbooks.
	Sensor	M Sensor	Maintenance message from DEFOR sensor module	Status messages from sensor. Evaluate logbook messages
	Sensor	M Sensor	Maintenance message from FINOR sensor module	Status messages from sensor. Evaluate logbook messages
	Sensor	M Sensor	Maintenance message from gas module	Status messages from sensor. Evaluate logbook messages
	Sensor	C Sensor	Check message from DEFOR sensor module	Status messages from sensor. Evaluate logbook messages
	Sensor	M Sensor	Check message from FINOR sensor module	Status messages from sensor. Evaluate logbook messages
	Sensor	M Sensor	Check message from gas module	Status messages from sensor. Evaluate logbook messages
	Reboot by user	C Reboot by user	Reboot by user	Reboot by user
	Tag: BVS table	Tag: BVS table	Incorrect parameter in BVS table	Error in BCU configuration in BVS table
	Fct. Button / Customer fct.	Fct. Button / Customer fct.	Incorrect parameter for function buttons	Error in BCU configuration for function buttons
	Adj./Val. error	Adj./Val. error	Incorrect parameter in adjustment/validation table	Error in BCU configuration for adjustment / validation parameters
	Tag: BVI table	Tag: BVI table	Incorrect parameter in BVI table	Error in BCU configuration in BVI table
	Tag: Measured value config.	Tag: Measured value config.	Incorrect parameter in MVI table	Error in BCU configuration in MVI table
	Tag: Modbus out	Tag: Modbus out	Incorrect parameter in Modbus table	Error in BCU configuration in Modbus table
	Tag: Analog out	Tag: Analog out	Incorrect parameter for analog outputs	Error in BCU configuration for analog outputs. Check and correct settings
	Tag: Digital out	Tag: Digital out	Incorrect parameter for digital outputs	Error in BCU configuration for digital outputs
	Tag: Test gas table	Tag: Test gas table	Incorrect parameter in test gas table	Error in BCU configuration in test gas table
	AO range	AO range	Incorrect parameter for analog output ranges	Error in BCU configuration for analog output ranges.
	FO failure (formula res.)	F FO failure (formula res.)	Failure group message for device	Failure group message for device. Check further logbook entries.
	CO check (formula res.)	C CO check (formula res.)	Check group message for device	Check group message for device. Check further logbook entries.
	UO uncertain (formula res.)	U UO uncertain (formula res.)	Uncertain group message for device	Uncertain group message for device. Check further logbook entries.

	Logbook text (Display)	Logbook text (SOPAS ET)	Description	Interpretation and possibly correction
	M0 maint. request (formula res.)	M M0 maint. request (formula res.)	Maintenance group message for device	Maintenance group message for device. Check further logbook entries.
	BV11 Start Adj./Val. 1	BV11 Start Adj./Val. 1	Input to start function 1 adjustment / validation	Start of function status indicator was activated
	BV12 Start Adj./Val. 2	BV12 Start Adj./Val. 2	Input to start function 2 adjustment / validation	Start of function status indicator was activated
	BV13 Start Adj./Val. 3	BV13 Start Adj./Val. 3	Input to start function 3 adjustment / validation	Start of function status indicator was activated
	BV14 Start Adj./Val. 4	BV14 Start Adj./Val. 4	Input to start function 4 adjustment / validation	Start of function status indicator was activated
	BV15 Start Adj./Val. 5	BV15 Start Adj./Val. 5	Input to start function 5 adjustment / validation	Start of function status indicator was activated
	BV16 Start Adj./Val. 6	BV16 Start Adj./Val. 6	Input to start function 6 adjustment / validation	Start of function status indicator was activated
	BV17 Start Adj./Val. 7	BV17 Start Adj./Val. 7	Input to start function 7 adjustment / validation	Start of function status indicator was activated
	BV18 Start Adj./Val. 8	BV18 Start Adj./Val. 8	Input to start function 8 adjustment / validation	Start of function status indicator was activated
	BV19 Abort Adj./Val.	BV19 Abort Adj./Val.	Input to abort the activated adjustment / validation	Status indicator. Abort adjustment / validation procedure
	BV110 Failure	F BV110 Failure	Input for failure message for device status	Status indicator, a failure message is generated via an external input.
	BV111 Maint. Request	M BV111 Maintenance Request	Input for maintenance message for device status	Status indicator, a maintenance request was triggered via the assigned input.
	BV112 Pump off	BV112 Pump off	Input to pump switch-off for the device	Status indicator. Stop command for gas pump was activated.
	BV113 Test gas fault	M BV113 Test gas fault	Input for message of a test gas fault	Status indicator, a test gas fault was triggered via the assigned input.
	BV114 Lock Adj./Val.	BV114 Lock Adj./Val.	Input for an adjustment and validation lock	Status indicator. Lock for adjustments or validations has been set.
	BVG1 Start Adj./Val. 1	BVG1 Start Adj./Val. 1	Automatic adjustment/validation function was manually started	Status indicator. Display of active function. Function runs with a time limit
	BVG2 Start Adj./Val. 2	BVG2 Start Adj./Val. 2	Automatic adjustment/validation function was manually started	Status indicator. Display of active function. Function runs with a time limit
	BVG3 Start Adj./Val. 3	BVG3 Start Adj./Val. 3	Automatic adjustment/validation function was manually started	Status indicator. Display of active function. Function runs with a time limit
	BVG4 Start Adj./Val. 4	BVG4 Start Adj./Val. 4	Automatic adjustment/validation function was manually started	Status indicator. Display of active function. Function runs with a time limit
	BVG5 Start Adj./Val. 5	BVG5 Start Adj./Val. 5	Automatic adjustment/validation function was manually started	Status indicator. Display of active function. Function runs with a time limit
	BVG6 Start Adj./Val. 6	BVG6 Start Adj./Val. 6	Automatic adjustment/validation function was manually started	Status indicator. Display of active function. Function runs with a time limit
	BVG7 Start Adj./Val. 7	BVG7 Start Adj./Val. 7	Automatic adjustment/validation function was manually started	Status indicator. Display of active function. Function runs with a time limit
	BVG8 Start Adj./Val. 8	BVG8 Start Adj./Val. 8	Automatic adjustment/validation function was manually started	Status indicator. Display of active function. Function runs with a time limit
	BVG9 Abort Adj./Val.	BVG9 Abort Adj./Val.	Automatic adjustment/validation function was manually aborted	Status indicator. Abort of active function.
	BVG11 Maintenance mode	C BVG11 maintenance	Maintenance status is activated	Status indicator. Display of active function.
	BVG12 Pump off	BVG12 Pump off	Gas pump was manually switched off.	Status indicator
	BV01 Pump off	BV01 Pump off	Internal or external gas pump is switched off	Status indicator. "Pump off" activated

	Logbook text (Display)	Logbook text (SOPAS ET)	Description	Interpretation and possibly correction
	BV04 Sample gas	BV04 Sample gas	Sample gas path is switched	Status indicator. No test gas is active. The sample gas path to the measuring point is switched
	BV05 Test gas 1	BV05 Test gas 1	Test gas No. 1 is active for adjustment or validation	Status message. Device in Check status. Test gas 1 is active.
	BV06 Test gas 2	BV06 Test gas 2	Test gas No. 2 is active for adjustment or validation	Status message. Device in Check status. Test gas 2 is active.
	BV07 Test gas 3	BV07 Test gas 3	Test gas No. 3 is active for adjustment or validation	Status message. Device in Check status. Test gas 3 is active.
	BV08 Test gas 4	BV08 Test gas 4	Test gas No. 4 is active for adjustment or validation	Status message. Device in Check status. Test gas 4 is active.
	BV09 Test gas 5	BV09 Test gas 5	Test gas No. 5 is active for adjustment or validation	Status message. Device in Check status. Test gas 5 is active.
	BV010 Test gas 6	BV010 Test gas 6	Test gas No. 6 is active for adjustment or validation	Status message. Device in Check status. Test gas 6 is active.
	Limit 1	U Limit 1	Limit value 1 of measured value MVi triggered with status U link	Gas flow monitoring. Check gas lines. Check sample gas pump, replace sample gas pump as required
	Limit 2	F Limit	Limit value 2 of measured value MVi triggered with status U link	Gas flow monitoring. Check gas lines. Check sample gas pump, replace sample gas pump as required
	Timeout	F Timeout	Measured value update from sensor failed with status F link	Check sensor connection. Restart device. *3
	BVS Flow (Gas module)	F BVS Flow (Gas module)	Internal gas flow monitoring message with device status Fault	Status of internal gas flow monitoring. Check logbook. Check pump status. Replace sample gas pump as required
	BVS Flow (Gas module)	U BVS Flow (Gas module)	Internal gas flow monitoring message with device status Uncertain	Status of internal gas flow monitoring. Check logbook. Check pump status. Replace sample gas pump as required
	BVS Moisture (Gas module)	F BVS Moisture (Gas module)	Check message from internal moisture sensor linked with device status Fault	Status of internal moisture sensor. Dry the measuring system. Dry the gas lines. Service required for drying
	BVS Standby	C BVS Standby	External Standby message linked with device status Check	Check status of external standby message. Check cables and signal paths. Switch setting on Standby
	BVS Sample conditioning 1	C BVS Sample conditioning	Message from sample conditioning linked with device status Check	Check sampling probe and cooler of measuring point 1. Check cables and signal paths. Replace components as required
	BVS Sample conditioning 2	C BVS Sample conditioning	Message from sample conditioning linked with device status Check	Check sampling probe and cooler of measuring point 2. Check cables and signal paths. Replace components as required
	BVS Sample conditioning 3	C BVS Sample conditioning	Message from sample conditioning linked with device status Check	Check sampling probe and cooler of measuring point 3. Check cables and signal paths. Replace components as required
	BVS Sample conditioning 4	C BVS Sample conditioning	Message from sample conditioning linked with device status Check	Check sampling probe and cooler of measuring point 4. Check cables and signal paths. Replace components as required

* = Only for O2 on gas module

2* = Replace BCU module. After the replacement, update the number of measuring points and the test gas concentration.

3* = Check network cables between the modules and external. If the error cannot be corrected *2

11.2 Consumable parts, wearing parts and spare parts

Analyzer spare parts	Part number
Exchange analyzer; DeSO _x (SO ₂ , CO ₂ , optional O ₂)	2077537
Exchange analyzer; full configuration (SO ₂ , CO ₂ , NO, NO ₂ , optional O ₂)	2077538
Analyzer power supply unit AC 93-264/DC210-370: 24V 10A	2050772

Analyzer spare parts	Part number
I/O module analyzer	2050775
Micro SD card (with last operator backup)	2076727
FINOR Loan module, complete	2077519
FINOR spare part, complete	2075572
Cover for FINOR	2077458
O ₂ module OXOR E, consumable parts set	2054673
Spare gas module, complete, tube with OXOR-E	2074292
Gas module loan module, tube with OXOR-E	2077528
Spare SO ₂ module DEFOR, complete	2075492
Spare Nox module DEFOR, complete	2077536
Analyzer module, complete, DeSO _x with L bracket	2077535
Analyzer module, complete, DeNO _x /DeSO _x with L bracket	2077539
Analyzer door, top, including control unit (BCU) and seal	2075527
Analyzer door, bottom	2075528
Door seals spare parts set	2077894
Backup F10AO (distributor board analyzer)	2062251
Distributor board (in analyzer top part, left)	2050770
CAN-BUS connection cable	Red: 2050766
	Blue: 2050767
	Yellow: 2050768

Spare parts for sample conditioning	Part number
Sample conditioning, complete, 230 V	2074151
Sample conditioning, complete, 115 V	2074152
Sample gas cooler, complete, 230 V	6053968
Sample gas cooler, complete, 115 V	6053969
Hose pump spare parts set	2075806
Solenoid valve, sample conditioning	2077626

Distributor unit spare parts	Part number
Distributor unit complete, 1 measuring point, 115 V	2074154
Distributor unit complete, 2 measuring points, 115 V	2074156
Distributor unit complete, 3 measuring points, 115 V	2075154
Distributor unit complete, 4 measuring points, 115 V	2075156
Distributor unit complete, 1 measuring point, 230 V	2074153
Distributor unit complete, 2 measuring points, 230 V	2074155
Distributor unit complete, 3 measuring points, 230 V	2075153
Distributor unit complete, 4 measuring points, 230 V	2075155
Cotton filter, complete	2073961
Sample gas fine filter	
Sample gas pump 115 V, spare parts set	2075794
Sample gas pump 230 V, spare parts set	2075793
Solenoid valve distributor unit	2075792
Sample gas valve	6054057

Distributor unit spare parts	Part number
Valve block for 2 measuring points	2074159
Valve block for 3 measuring points	2074160
Valve block for 4 measuring points	2074161
Flowmeter	2075801
Leak tightness check spare parts set	2078561
Power supply unit 2.2 A, distributor unit	6010135

Sampling probe spare part	Part number
Probe, complete	6053728
Sampling tube, single, 0.4 m	5329476
Sampling tube, single, 0.6 m	5329477
Sampling tube, single, 0.8 m	5329478
Flange seal	5306555
Probe filter	5329430
Seal spare parts set	2078541
Heating cartridge	2078558

Sample gas path spare part	Part number
Swagelok spare parts set	2075791
Swagelok straight	2050933
Swagelok elbow	2050934
Swagelok reducing union	2050935
Heated sample gas line 5 m , 115 V	6053923
Heated sample gas line 10 m , 115 V	6053924
Heated sample gas line 15 m , 115 V	6053925
Heated sample gas line 5 m , 230 V	6053746
Heated sample gas line 10 m , 230 V	6053747
Heated sample gas line 15 m , 230 V	6053748
PTFE line 4/6 mm (per meter)	5310243
PTFE hose D 2.5/4.0 internal tubing of modules (per meter)	2062254
Hose cutter	5329980

11.3 Compliances

Compliances

- MARPOL Annex VI and NTC 2008 - MEPC.177(58)
- Guidelines for exhaust gas cleaning systems - MEPC.184(59), MEPC.259(68)
- DNV GL Rules for Classification and Construction, Part VI Additional Rules and Guidelines Chapter 7, Guidelines for the Performance of Type Approvals, Test Requirements for Electrical / Electronic Equipment and Systems
- ABS Rules for steel vessels: 1-1-4/7.7, 1-1-Appendix 3 and 4, 4-8-3/1.7/ 1.9/ 1.11/ 1.17/ 4-9-8/13
- CCS Rules Chapter 2, Part 7 of China Classification Society Rules for Classification of Sea-going Steel Ships and its Amendments.
- EC Directive: LVD (Low Voltage Directive)

EN 61010-1: Safety requirements for electrical equipment for measurement, control and laboratory use

- EC Directive: EMC (Electromagnetic Compatibility)
EN 61326: Electrical equipment for measurement, control and laboratory use, EMC requirements
- Cross-sensitivity correction according to DIN EN 15267-1: Air quality - certification of automated measuring systems

Further standards and directives: See Declaration of Conformity provided with the device.

Electrical compliance

- CE
- DNV GL Rules

Australia

Phone +61 (3) 9457 0600
1800 33 48 02 – tollfree
E-Mail sales@sick.com.au

Austria

Phone +43 (0) 2236 62288-0
E-Mail office@sick.at

Belgium/Luxembourg

Phone +32 (0) 2 466 55 66
E-Mail info@sick.be

Brazil

Phone +55 11 3215-4900
E-Mail comercial@sick.com.br

Canada

Phone +1 905.771.1444
E-Mail cs.canada@sick.com

Czech Republic

Phone +420 234 719 500
E-Mail sick@sick.cz

Chile

Phone +56 (2) 2274 7430
E-Mail chile@sick.com

China

Phone +86 20 2882 3600
E-Mail info.china@sick.net.cn

Denmark

Phone +45 45 82 64 00
E-Mail sick@sick.dk

Finland

Phone +358-9-25 15 800
E-Mail sick@sick.fi

France

Phone +33 1 64 62 35 00
E-Mail info@sick.fr

Germany

Phone +49 (0) 2 11 53 010
E-Mail info@sick.de

Greece

Phone +30 210 6825100
E-Mail office@sick.com.gr

Hong Kong

Phone +852 2153 6300
E-Mail ghk@sick.com.hk

Hungary

Phone +36 1 371 2680
E-Mail ertekezes@sick.hu

India

Phone +91-22-6119 8900
E-Mail info@sick-india.com

Israel

Phone +972 97110 11
E-Mail info@sick-sensors.com

Italy

Phone +39 02 27 43 41
E-Mail info@sick.it

Japan

Phone +81 3 5309 2112
E-Mail support@sick.jp

Malaysia

Phone +603-8080 7425
E-Mail enquiry.my@sick.com

Mexico

Phone +52 (472) 748 9451
E-Mail mexico@sick.com

Netherlands

Phone +31 (0) 30 229 25 44
E-Mail info@sick.nl

New Zealand

Phone +64 9 415 0459
0800 222 278 – tollfree
E-Mail sales@sick.co.nz

Norway

Phone +47 67 81 50 00
E-Mail sick@sick.no

Poland

Phone +48 22 539 41 00
E-Mail info@sick.pl

Romania

Phone +40 356-17 11 20
E-Mail office@sick.ro

Russia

Phone +7 495 283 09 90
E-Mail info@sick.ru

Singapore

Phone +65 6744 3732
E-Mail sales.gsg@sick.com

Slovakia

Phone +421 482 901 201
E-Mail mail@sick-sk.sk

Slovenia

Phone +386 591 78849
E-Mail office@sick.si

South Africa

Phone +27 10 060 0550
E-Mail info@sickautomation.co.za

South Korea

Phone +82 2 786 6321/4
E-Mail infokorea@sick.com

Spain

Phone +34 93 480 31 00
E-Mail info@sick.es

Sweden

Phone +46 10 110 10 00
E-Mail info@sick.se

Switzerland

Phone +41 41 619 29 39
E-Mail contact@sick.ch

Taiwan

Phone +886-2-2375-6288
E-Mail sales@sick.com.tw

Thailand

Phone +66 2 645 0009
E-Mail marcom.th@sick.com

Turkey

Phone +90 (216) 528 50 00
E-Mail info@sick.com.tr

United Arab Emirates

Phone +971 (0) 4 88 65 878
E-Mail contact@sick.ae

United Kingdom

Phone +44 (0)17278 31121
E-Mail info@sick.co.uk

USA

Phone +1 800.325.7425
E-Mail info@sick.com

Vietnam

Phone +65 6744 3732
E-Mail sales.gsg@sick.com

Detailed addresses and further locations at www.sick.com

