

# GM32 Ex

## In-situ Gas Analyzer Cross-Duct Version

Installation, Operation, Maintenance

**SICK**  
Sensor Intelligence.

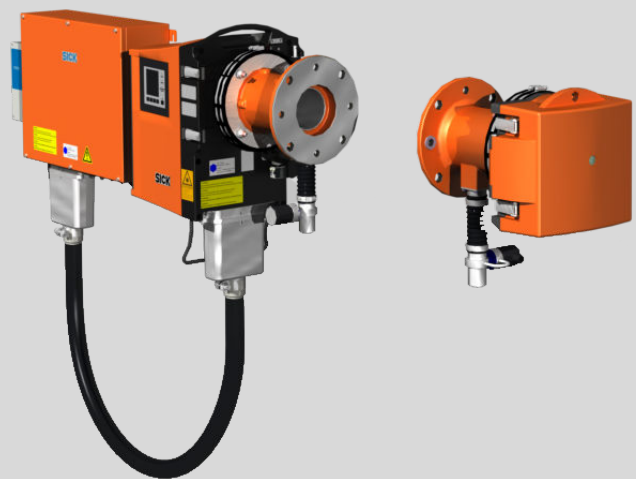

---

**Described product**

GM32 Ex

Cross-Duct version

**Manufacturer**

SICK AG  
Erwin-Sick-Str. 1  
79183 Waldkirch  
Germany

**Production location**

SICK AG  
Nimburger Str. 11  
79276 Reute  
Germany

**Legal information**

This work is protected by copyright. Any rights derived from the copyright shall be reserved for SICK AG. Reproduction of this document or parts of this document is only permissible within the limits of the legal determination of Copyright Law. Any modification, shortening or translation of this document is prohibited without the express written permission of SICK AG.

The trademarks stated in this document are the property of their respective owner.

© SICK AG. All rights reserved.

**Original document**

This document is an original document of SICK AG.



## Contents

<b>1</b>	<b>About this document.....</b>	<b>7</b>
1.1	Function of this document.....	7
1.2	Scope of application.....	7
1.3	Target groups / qualification requirements.....	7
1.4	Further information.....	7
1.5	Data integrity.....	7
1.6	Symbols and document conventions.....	8
1.6.1	Warning symbols.....	8
1.6.2	Warning levels / Signal words.....	8
1.6.3	Information symbols.....	9
<b>2</b>	<b>Safety information.....</b>	<b>10</b>
2.1	Main operating information.....	10
2.2	Warnings on the device.....	12
2.3	Intended use.....	12
2.3.1	Purpose of the device.....	13
2.3.2	Operation in potentially explosive atmosphere.....	13
2.4	Responsibility of user.....	14
<b>3</b>	<b>Product description.....</b>	<b>15</b>
3.1	Product identification.....	15
3.2	Device version.....	15
3.3	Device variants.....	16
3.4	Options.....	16
3.5	SOPAS ET (PC program).....	16
3.6	Reference cycle.....	17
3.7	Check cycle.....	17
3.8	Layout and function.....	19
3.9	Purge air unit.....	20
3.10	Explosion protection in accordance with ATEX.....	20
3.10.1	Zone separation GM32 EX ATEX 3G.....	20
3.10.2	Pressurized enclosure.....	21
3.10.2.1	.....	21
3.11	Connecting hose between SR-unit and junction box.....	22
<b>4</b>	<b>Transport and storage.....</b>	<b>23</b>
4.1	Transport safety device.....	23
4.2	Storage.....	23
<b>5</b>	<b>Mounting.....</b>	<b>24</b>
5.1	Information on installation in potentially explosive atmospheres.....	24
5.2	Preparing the sampling point.....	25
5.3	Scope of delivery.....	25
5.3.1	Checking the delivery state.....	26

5.4	Installation sequence.....	26
5.4.1	Overview of the installation steps (duct-side preparation)...	26
5.4.2	Install flanges with tube.....	26
5.4.3	Installing the connection unit.....	28
5.4.3.1	Fitting the FS850S.....	29
5.4.4	Installing the purge air unit.....	30
5.4.4.1	Start-up of the purge air supply.....	30
<b>6</b>	<b>Electrical installation.....</b>	<b>32</b>
6.1	Electrical installation safety information.....	32
6.2	Connection overview.....	34
6.2.1	Lines.....	35
6.3	Connecting interfaces .....	35
6.3.1	Connecting I/O interfaces (option).....	35
6.3.1.1	Connection diagram for variant 3G.....	36
6.3.1.2	Default values for interfaces.....	38
6.4	Connecting the connection hose to the SR-unit on the junction box....	39
6.5	Connecting pressure, temperature and purge air monitor .....	40
6.6	Connecting the potential equalization on the purge air fixture.....	40
6.7	Connecting the Ex overpressure control FS850S.....	41
6.8	Electrical connection of SR-unit.....	42
6.9	Preparing the power supply.....	43
6.10	Connecting the potential equalization to the SR-unit.....	44
<b>7</b>	<b>Commissioning.....</b>	<b>45</b>
7.1	Safety information for start-up.....	45
7.2	Material required .....	46
7.3	Check before start-up.....	46
7.4	Overview of start-up steps.....	46
7.5	Fitting the purge air fixtures on the flange with tube.....	47
7.6	Installing the device flange on the purge air fixture.....	47
7.7	Aligning device flanges and purge air fixtures.....	49
7.8	Connecting the protective gas on the SR-unit.....	50
7.8.1	Feeding protective gas.....	51
7.8.2	Switching the pressurized enclosure on.....	51
7.9	Installing the SR-unit and reflector unit on the device flange.....	52
7.10	Optical fine alignment of the SR-unit .....	52
7.11	Fitting the weatherproof cover (option).....	53
<b>8</b>	<b>Operation.....</b>	<b>55</b>
8.1	Safety.....	55
8.2	GM32 operator panel.....	55
8.2.1	LEDs.....	56
8.2.2	Function buttons.....	57
8.2.3	Setting the display contrast.....	58
8.2.4	Menu tree.....	58

8.2.4.1	Diagnosis.....	59
8.2.4.2	Check cycle - results of last check cycle.....	59
8.2.4.3	Alignment check (option) - automatic optical alignment check.....	60
8.2.4.4	Alignment adjust - manual optical alignment.....	60
8.2.4.5	Maintenance mode - set Maintenance mode .....	62
<b>9</b>	<b>Maintenance.....</b>	<b>64</b>
9.1	Safety .....	64
9.2	Maintenance plan .....	66
9.2.1	Consumable parts, expendable parts and spare parts.....	66
9.3	Preparation work.....	67
9.4	Function test of the pressurized enclosure system.....	67
9.5	Swiveling out and removing the SR-unit or reflector unit.....	68
9.6	Visual inspection.....	69
9.7	Cleaning the window.....	70
9.8	Check/replace the desiccant cartridge.....	70
9.9	Replacing the activated charcoal bag.....	71
9.10	Replacing the sender lamp.....	72
<b>10</b>	<b>Troubleshooting.....</b>	<b>75</b>
10.1	Safety.....	75
10.2	Visual inspection.....	76
10.3	Device not functioning.....	77
10.4	Overpressure monitoring failure.....	77
10.5	Measured values clearly incorrect.....	78
10.6	Sample gas penetrating.....	78
10.7	Corrosion on flange.....	78
10.8	Measured value blinks.....	78
10.9	Error messages.....	78
10.9.1	Example of an error message.....	78
10.9.2	Error messages.....	80
10.10	Repairing inadequate purge air supply.....	84
10.11	Malfunctions on the connection unit .....	84
<b>11</b>	<b>Decommissioning.....</b>	<b>85</b>
11.1	Safety information on shutting down.....	85
11.2	Decommissioning of subassemblies with explosion relevance.....	87
11.3	Removing the device.....	87
11.4	Environmentally compatible disposal .....	87
<b>12</b>	<b>Technical data.....</b>	<b>89</b>
12.1	System: GM32 Ex.....	89
12.2	GM32 Ex sender/receiver unit.....	90
12.3	Reflector unit GM32 Ex.....	90
12.4	Purge air fixture: Sender/receiver unit GM32 Ex.....	91
12.5	Purge air fixture: Reflector unit GM32 Ex.....	91

12.6	Connection unit, Ex version I/O module.....	91
12.7	Dimension drawings: Sender/receiver unit Ex version.....	92
12.8	Dimension drawings: Reflector unit.....	93
12.9	Dimension drawings: Ex purge air fixtures (on SR and reflector side)..	94
12.10	Dimension drawings: Connection unit version 3G.....	95
12.11	Dimension drawings: Mounting flange DN100.....	96
12.12	Dimension drawing, weatherproof cover, SR-unit.....	96
12.13	Technical data for enclosure pressurization system.....	96
12.13.1	Technical data protective gas.....	96
12.13.2	Technical data enclosure.....	97
12.13.3	Pressurized enclosure system settings.....	97
<b>13</b>	<b>Annex.....</b>	<b>98</b>
13.1	Conformities.....	98
13.2	Electrical protection.....	98
13.3	Ex certifications.....	98
<b>14</b>	<b>Index.....</b>	<b>100</b>

# 1 About this document

## 1.1 Function of this document

These Operating Instructions describe:

- Device components
- Installation
- Operation
- Maintenance work required for reliable operation

## 1.2 Scope of application

These Operating Instructions are only valid for the in-situ gas analyzer with the designation GM32 Ex Cross-Duct.

They are not valid for other in-situ gas analyzers from SICK.

## 1.3 Target groups / qualification requirements

Table 1: Qualification requirements

Tasks	User groups	Qualification
Assembly	Operator / system integrator	e.g. plant operator, unskilled in measurement technology
Electrical installation	Qualified personnel	Authorized electrician (authorized skilled electrician or person with similar training)
Initial start-up	Authorized operator ⓘ	General knowledge in measurement technology, specialist device knowledge (possibly customer training at SICK)
Returning to operation		
Decommissioning	<ul style="list-style-type: none"> <li>• Operator / system integrator</li> <li>• Authorized operator ⓘ</li> </ul>	<ul style="list-style-type: none"> <li>• e.g. plant operator, unskilled in measurement technology</li> <li>• Authorized electrician (authorized skilled electrician or person with similar training)</li> </ul>
Operation		
Maintenance		
Troubleshooting		

## 1.4 Further information

- Operating Instructions of the purge air supply
- Final inspection record
- CD-ROM with SOPAS ET
- Optional: Technical information
- Optional: Operating Instructions Modular System I/O

3G / Zone 2

- FS850S Pressurized Enclosure Manual
- Manual, Purge medium valve SVD.L.2.-AI00



### NOTE

- ▶ Observe all supplied documents.

## 1.5 Data integrity

SICK AG uses standardized data interfaces such as, for example, standard IP technology, in its products. The focus here is on product availability and features.











SICK AG always assumes that the customer is responsible for the integrity and confidentiality of data and rights involved in connection with using the products.

In all cases, the customer is responsible for the implementation of safety measures suitable for the respective situation, e.g., network separation, firewalls, virus protection and patch management.

## 1.6 Symbols and document conventions

### 1.6.1 Warning symbols

Table 2: Warning symbols

Symbol	Significance
	Hazard (general)
	Hazard by voltage
	Hazard in potentially explosive atmospheres
	Hazard by explosive substances/mixtures
	Hazard by toxic substances
	Hazard by unhealthy substances
	Hazard by ultraviolet radiation (UV light)
	Hazard by oxidizing substances
	Hazard by high temperature
	Hazard for the environment/nature/organic life

### 1.6.2 Warning levels / Signal words

#### **DANGER**

Risk or hazardous situation which will result in severe personal injury or death.

#### **WARNING**

Risk or hazardous situation which could result in severe personal injury or death.

#### **CAUTION**

Hazard or unsafe practice which could result in less severe or minor injuries.

#### **Notice**

Hazard which could result in property damage.





Note

Hints

**1.6.3 Information symbols**

*Table 3: Information symbols*

Symbol	Significance
	Information on consistency of the product relative to Guideline 2014/34/EU (ATEX)
	Important technical information for this product
	Important information on electric or electronic functions

## 2 Safety information

### 2.1 Main operating information

#### Work on the device

---



**WARNING**  
**Risk of explosion**

Work on the device assumes an Ex free zone at the installation location otherwise there is an explosion risk.

- ▶ Ensure the work area is Ex free when working on the device.
- 



**DANGER**  
**Risk for system safety through work on the device not described in these Operating Instructions**

Carrying out work on the device not described in these Operating Instructions or associated documents can lead to unsafe operation of the measuring system and therefore endanger plant safety.

- ▶ Only carry out the work on the device described in these Operating Instructions and associated documents.
- 



**DANGER**  
**Risk of explosion through incorrect performance of maintenance work**

Incorrect performance of maintenance work in potentially explosive atmospheres can cause serious injuries to people and damage during operation.

- Maintenance work and start-up activities as well as checks must be performed by experienced/trained technicians having knowledge of the relevant rules and regulations for potentially explosive atmospheres, especially:
    - Ignition protection types
    - Installation procedures
    - Zone classification
  - Standards to be applied:
    - IEC 60079-14, Annex F: Knowledge, skills and competencies of responsible persons, operatives and designers
    - IEC 60079-17: Electrical installations inspection and maintenance
    - IEC 60079-19: Equipment repair, overhaul and reclamation
- 

#### Noxious UV radiation

---



**DANGER**  
**Damage to eyes and skin by UV radiation**

The in-situ gas measuring device GM32 emits UV radiation when the SR-unit or reflector unit is opened during operation. Exposure of the unprotected skin and eyes to radiation is dangerous to health.

- ▶ Disconnect the power supply of the device before opening the device.
  - ▶ Wear suitable protective goggles and protective gloves when work on the open device with the power supply connected is performed.
-

---

### Escaping hot gas

---

**DANGER****Risk of fire through hot gas escaping in installations with overpressure conditions**

On installations with overpressure, the purge air hose can be severely damaged by escaping hot gas and can catch fire depending on the temperature. On installations with overpressure and gas temperatures over 200 °C at the same time:

- ▶ Regularly check the functionality of the reverse flow safeguard in the purge air fixtures.
- 

### Potential equalization

---

**CAUTION****Device damage through incorrect or non-existing grounding**

To avoid device damage, a correctly connected potential equalization is mandatory on all system components with external ground connections in all operating conditions.

- ▶ Connect a potential equalization on all planned points on the device components.
  - ▶ Ensure the potential equalization is connected during all work on the device described in these Operating Instructions.
- 

### Contamination caused by purge air failure

---

**CAUTION****A faulty purge air supply can damage the measuring system**

The measuring system can no longer be protected from contaminated sample gas and is damaged.

- ▶ When the purge air supply is faulty, immediately perform all actions described in these Operating Instructions.
- 

### Responsibility for system safety

---

**ATTENTION****Responsibility for the safety of a system**

The person setting the system up is responsible for the safety of the system in which the device is integrated.

---

## 2.2 Warnings on the device

### GM32 Ex SR-unit

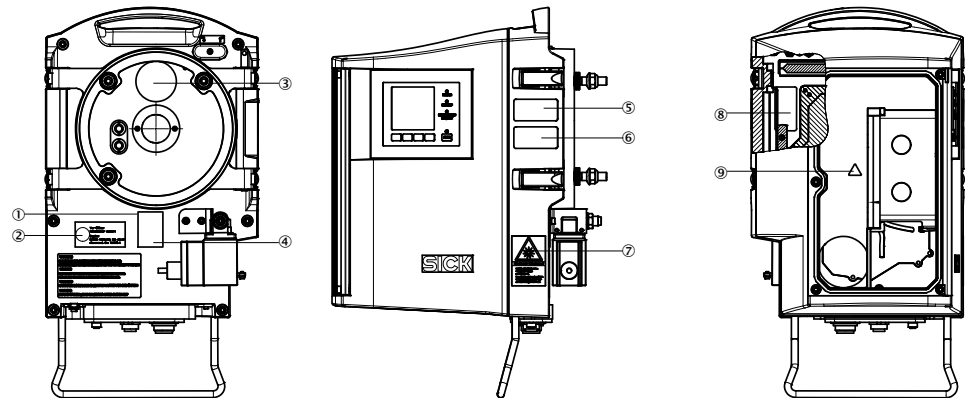

Figure 1: Sender/receiver unit from the front, the side and with the intermediate housing open

#### Sender/receiver unit, front side

- 1 Warning sign protective gas:
  - o Protective gas outlet
  - o Risk of suffocation when using inert gases
  - o 20 minutes waiting time before opening the enclosure
- 2 Warning sign: Pull power plug before opening the device
- 3 Mandatory sign: Wear eye protection
- 4 Warning sign: Do not disconnect when live

#### Sender/receiver unit, right side

- 5 Type plate GM32 Ex 3G
- 6 Sampling point designation (optional)
- 7 Danger sign: UV light

#### Sender/receiver unit, intermediate housing

- 8 Type plate GM32 Ex 3G
- 9 Warning sign: Hot surface

### GM32 Ex connection unit

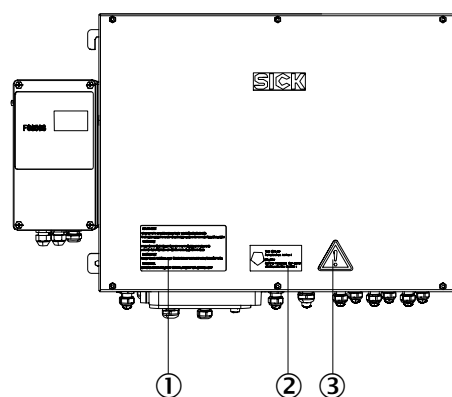

#### Connection unit for GM32 Ex, front side

- 1 Warning sign protective gas:
  - o Protective gas outlet
  - o Risk of suffocation when using inert gases
  - o 20 minutes waiting time before opening the enclosure
- 2 Warning sign: Pull power plug before opening the device
- 3 General warning sign: Warning of a danger area

Figure 2: GM32 Ex connection unit

## 2.3 Intended use

### 2.3.1 Purpose of the device

The device serves exclusively for emission and process monitoring of gases in industrial plants.

The device measures continuously directly in the gas duct (in-situ).

### 2.3.2 Operation in potentially explosive atmosphere



#### 3G / Zone 2: Connection unit and sender/receiver unit

- The GM32 Ex corresponds to the ATEX category (according to ATEX 2014/34/EC):
  - ⊕ II 3G Ex pzc op is [ia] IIC T3 Gc
- GM32 Ex meets the following IECEx qualification:
  - Ex pzc op is [ia] IIC T3 Gc
- Special conditions (X identification)
  - A measuring function for explosion protection is not part of the EC type approval
  - The duct with sample gas contact must be a non-potentially explosive atmosphere when overpressure against the atmosphere is present in the duct
  - If the duct has underpressure against the atmosphere, this area may correspond to Zone 2
- Observe the Ex identification.  
The Ex identification is on the type plate. Example:  
SICK  
GM32-xxx-EX3G (xxx=internal type number)  
SN: yyyy yyyyy (serial number)  
-20 °C ≤ Ta ≤ 55 °C  
⊕
- Explosion protection relating to optical radiation in the measuring channel  
The explosion protection relating to optical radiation in the measuring channel is satisfied in accordance with the temperature range (-20° ... +60 °C) specified by ATX/IECEx. The plant operator must evaluate Ex atmospheres possibly present for exhaust gas temperatures exceeding this range separately and take suitable protective measures!
  - ▷ Location of Ex relevant subassemblies, see Chapter “Design and Function”.
  - ▷ Do not remove, add or modify any components to or on the device unless described and specified in the official manufacturer information. Otherwise the approval for the device for use in potentially explosive atmospheres becomes void.
  - ▷ Adhere to the maintenance intervals, see Chapter “Maintenance plan”.
  - ▷ After switching off the main power supply: Wait 20 minutes before opening the enclosure.

### 2.4 Responsibility of user

#### Designated users

see "Target groups / qualification requirements", page 7.

#### Correct project planning

- Basis of this Manual is the delivery of the device according to the preceding project planning (e.g., based on the SICK application questionnaire) and the relevant delivery state of the device (see delivered System Documentation).
  - ▷ Contact SICK Customer Service if you are not sure whether the device corresponds to the state defined during project planning or to the delivered system documentation.

#### Special local conditions

In addition to the information in these Operating Instructions, follow all local laws, technical rules and company-internal operating directives applicable wherever the device is installed.

#### Read the Operating Instructions

- ▶ Read and observe these Operating Instructions.
- ▶ Observe all safety instructions.
- ▶ If anything is not clear: Please contact SICK Customer Service.

#### Retain documents

These Operating Instructions:

- ▶ Must be available for reference.
- ▶ Must be passed on to new owners.

### 3 Product description

#### 3.1 Product identification

Product name	GM32 Ex
Device version	Cross-Duct version
Manufacturer	SICK AG Erwin-Sick-Str. 1 D-79183 Waldkirch · Germany
Type plates	<ul style="list-style-type: none"> <li>• Sender/receiver unit: On the right side and on the intermediate enclosure</li> <li>• Connection unit: On the right and inside</li> <li>• On the purge air fixture: On the tube</li> <li>• On the reflector</li> </ul>

#### 3.2 Device version

Type code for Ex device versions

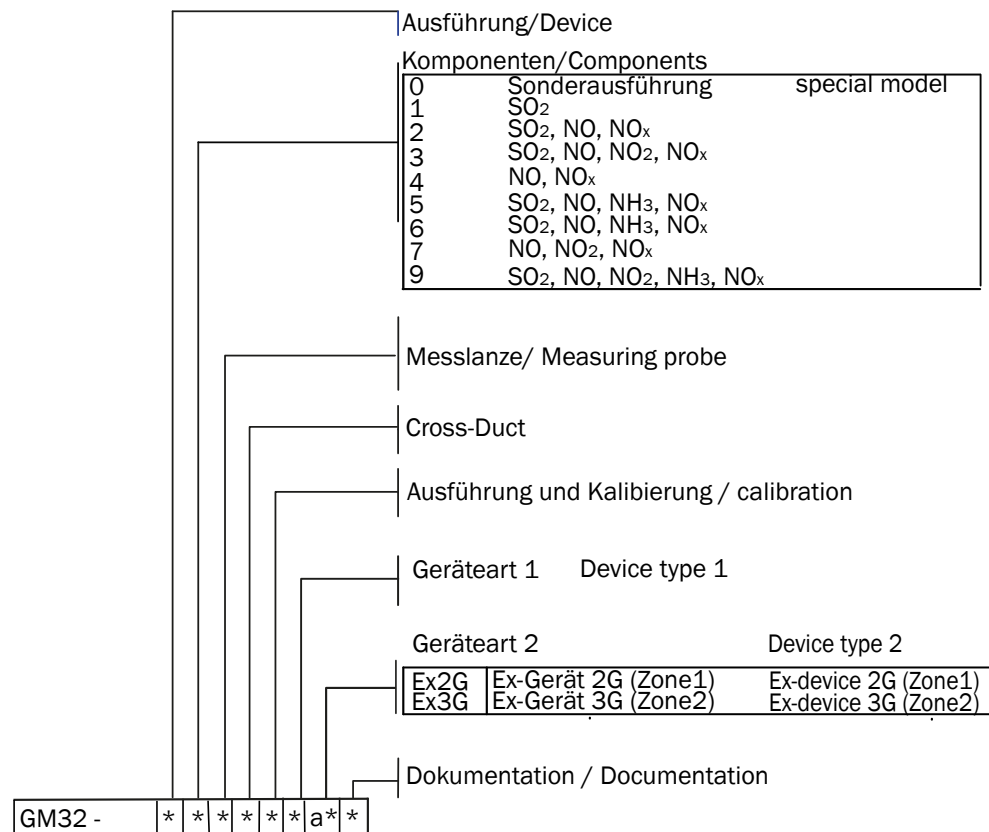

Figure 3: Type code for GM32 Ex

\*△ Ex version designation

#### Type code for Ex connection unit

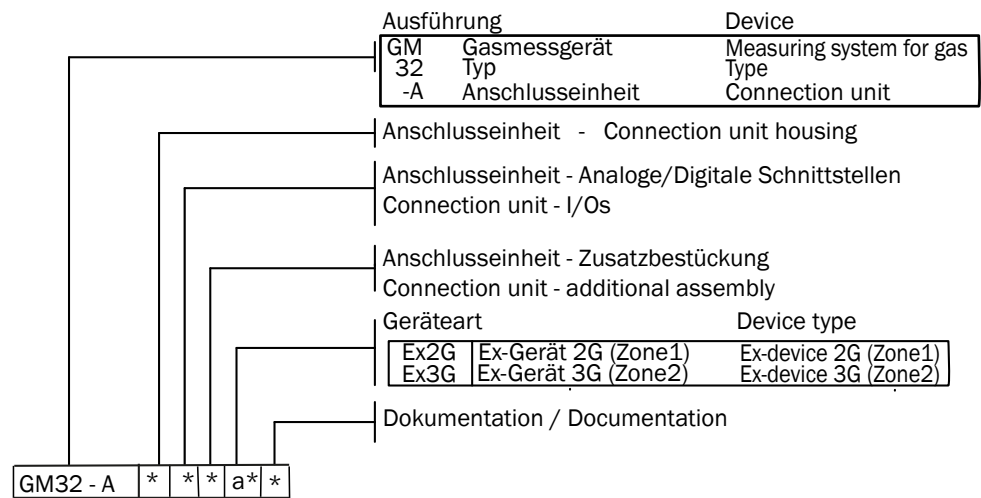

Figure 4: Type code for GM32 Ex connection unit

△\* Ex connection unit designation

### 3.3 Device variants

#### “Basic” variant

- Reference cycle, [see "Reference cycle", page 17](#): Correction of internal drifts. Zero point check
- Automatic mirror tracking: Automatic adjustment of optical axis
- Logbook: System messages are recorded in a logbook
- Network: Ethernet interface with OPC standard
- Ethernet: 1 x fiber optics connection on connection unit

#### “Pro” variant

As “Basic” variant. In addition:

- TÜV-tested for equipment subject to authorization
- Check cycle, [see "Check cycle", page 17](#): Reference cycle (as in the “Basic” variant) followed by a cycle to check and output the zero and check point. The check cycle creates the QAL3 values (quality assurance of automated measuring systems). The QAL3 values can be displayed with SOPAS ET.
- Operator panel: Measured values, operational state and malfunction messages are displayed in clear text on a monitor
- QAL3 Tool (CUSUM chart)

### 3.4 Options

- I/O modules (Analog Out, Digital Out, Digital In, Analog In)
- SCU: Operating unit to control several analyzers with SCU capability (see SCU Operating Instructions)
- Super calibration: Several applications/calibrations, e.g., for spare devices
- Measuring range switch-over (analog outputs). The valid measuring range is signaled via a digital output (configured).
- Weatherproof cover

### 3.5 SOPAS ET (PC program)

SOPAS ET enables:



- Additional configuration
- Access to logbook GM32

SOPAS ET runs on an external PC connected via the Ethernet interface, see "[Connection overview](#)", page 34, to the GM32.



#### NOTE

Further information on SOPAS ET:

- Technical Information GM32
- SOPAS ET Help menu

### 3.6 Reference cycle

Internal drifts correction in an adjustable interval (standard: 1 hour, setting: SOPAS ET) or per command (with SOPAS ET).

Measured value output during the reference cycle: Last valid measured value.

### 3.7 Check cycle

Check cycle = reference cycle + following check and output of the zero and check points (70% of full scale value).

#### Start a check cycle via

- Set interval (SOPAS ET)
- Command via SOPAS ET
- External signal (optional)

#### Purpose of check cycle

- Check of the zero point and a reference point for each component without feeding test gases
- Meets the requirements of EN14181
- Replaces drift monitoring with test gases according to QAL3

#### Zero point

An internal zero point reflector is swiveled in time-controlled in adjustable intervals. The emitted light is reflected back in the sender/receiver unit to the detector, the zero spectrum is evaluated with the calibration function and thus the zero points of all ducts measured and output.

Signaling of maintenance request: Deviation from zero  $> \pm 2\%$  of the FS.

#### Check cycle

An internal swivel element with two reference filters and an NO-filled cell is swiveled in during the check cycle in addition to the zero point reflector and the reference value and concentration value measured. These control values are scaled to 70% of the selected measuring range.

Signaling of maintenance request: Deviation from setpoint value  $> \pm 2\%$  of the FS.

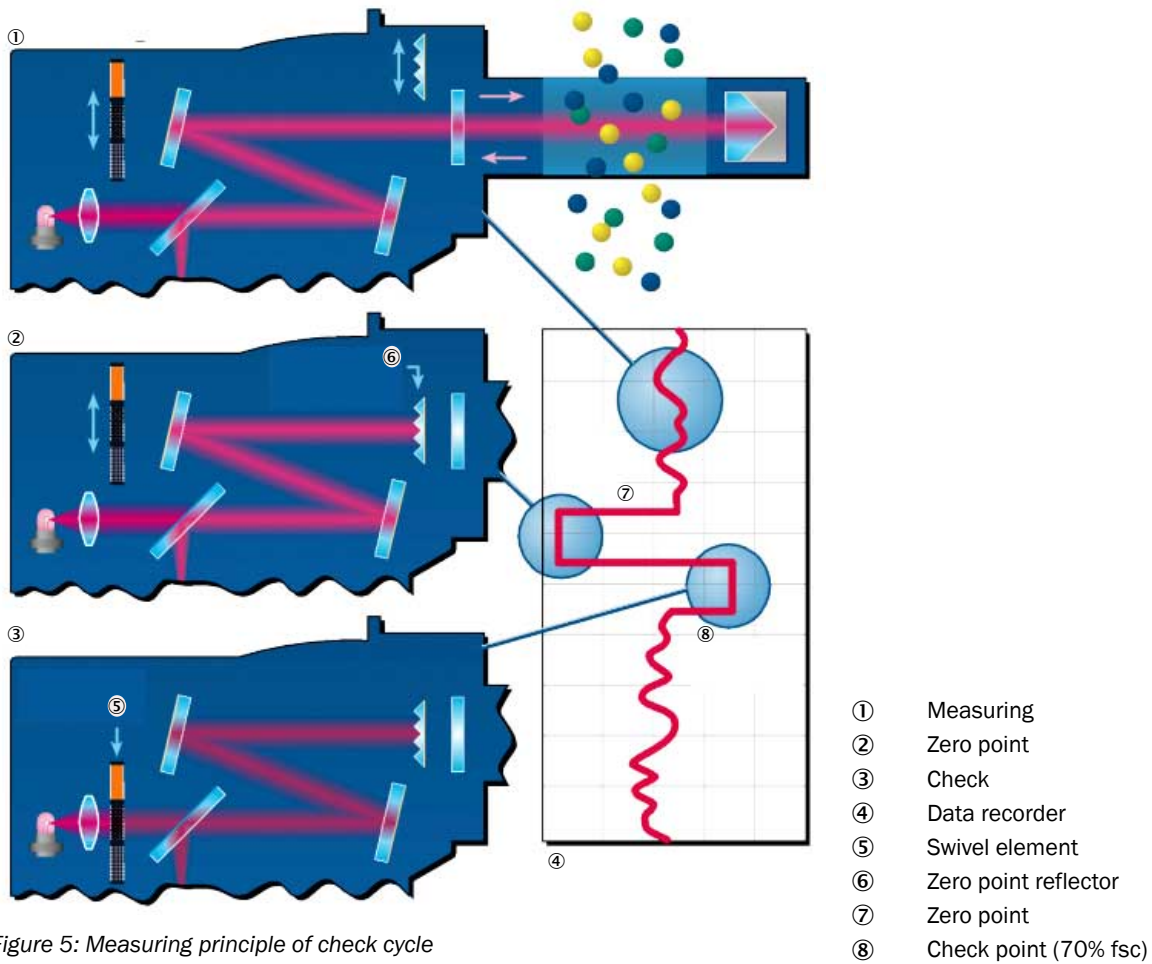

Figure 5: Measuring principle of check cycle

Output of measured values during the check cycle	Last valid measured value
Signal output during the check cycle (optional digital output or OPC interface)	Not_measuring
Output of determined zero and reference values on analog outputs	<ul style="list-style-type: none"> <li>• Directly after the check cycle</li> <li>• On request via a digital input (option)</li> </ul>
Signal output during the output	Output_control values (optional digital output or OPC interface) Output sequence: 1 Zero values for 90 s 2 Reference values for 90 s
Display of zero and reference values, the last check cycle as well as QAL3 values in SOPAS ET	Menu: Diagnosis/check values
Display when check of NO cell failed	<ul style="list-style-type: none"> <li>• All interfaces: Results of NO cell</li> <li>• All interfaces: "0" is output instead of zero and reference values</li> <li>• Analog output: Live Zero</li> <li>• Results of zero and reference measurement are irrelevant</li> </ul>

### 3.8 Layout and function

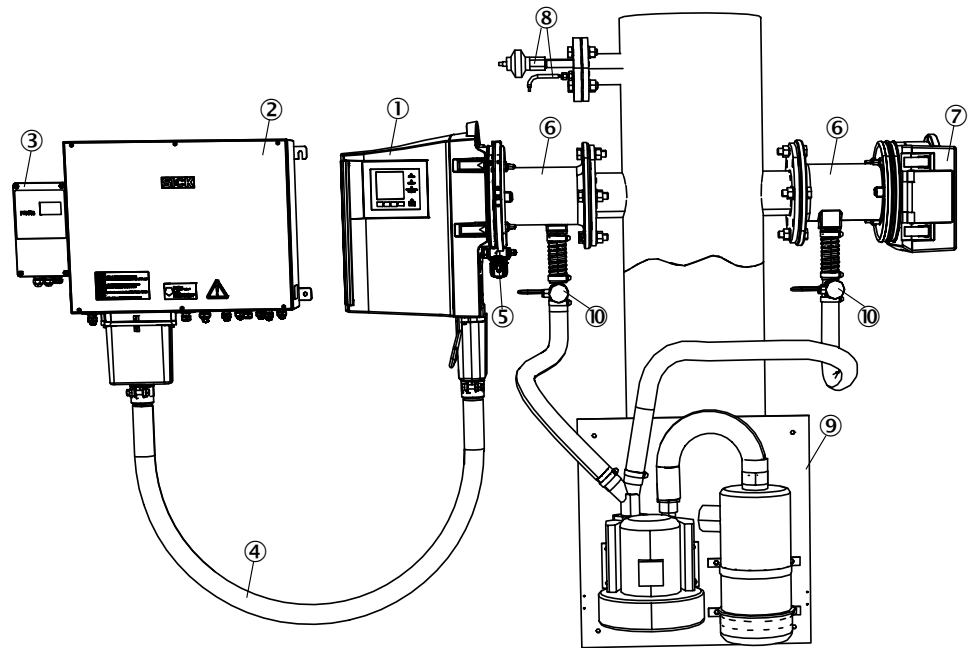

Figure 6: Components of the GM32 Ex 3G version

- ① Sender/receiver unit GM32-xxxxxEX3G (SR-unit)
- ② Connection unit GM32- A2xxEX3G
- ③ Control unit FS850S EEx p
- ④ Metallic connecting hose between sender/receiver unit and connection unit
- ⑤ Purge valve SVP3 G 3/8"-300L EEx p
- ⑥ Purge air fixture (without electronics)
- ⑦ Reflector unit (without electronics)
- ⑧ Temperature and pressure measurement
- ⑨ Purge air supply
- ⑩ Pressure switch for purge air monitor

#### Function

- The device serves for continuous measurement of gas concentrations in industrial plants
- The device is an in-situ measuring system which means measuring is done directly in the gas carrying duct
- Measuring components: SO<sub>2</sub>, NO, NO<sub>2</sub> and NH<sub>3</sub> (device specific) as well as the reference variables temperature and pressure
- Measuring principle: Differential Optical Absorption Spectroscopy (DOAS)
- To maintain measuring reliability, a permanent air flow (optics purge air) protects and keeps the optics free from soot and dust particles as well as condensate and moisture condensation
- Ignition protection type “pressurized enclosure” is applicable when using the GM32 Ex in potentially explosive atmospheres. All relevant enclosures of the sender/receiver unit and connection unit connected together via a pressure-proof metal hose are purged with a protective gas. The protective gas can be air suctioned in from the non-potentially explosive atmosphere or an inert gas.

### 3.9 Purge air unit

- The purge air unit supplies filtered ambient air to the purge air fixtures.
- Protects the window of the SR-unit and the reflector against contamination and high gas temperatures
- One purge air unit each for SR-unit and reflector unit
- The purge air is blown into the gas duct through the “flange with tube”.



**NOTE**

Further information on the purge air unit, see Operating Instructions of the purge air unit.

### 3.10 Explosion protection in accordance with ATEX

#### 3.10.1 Zone separation GM32 EX ATEX 3G

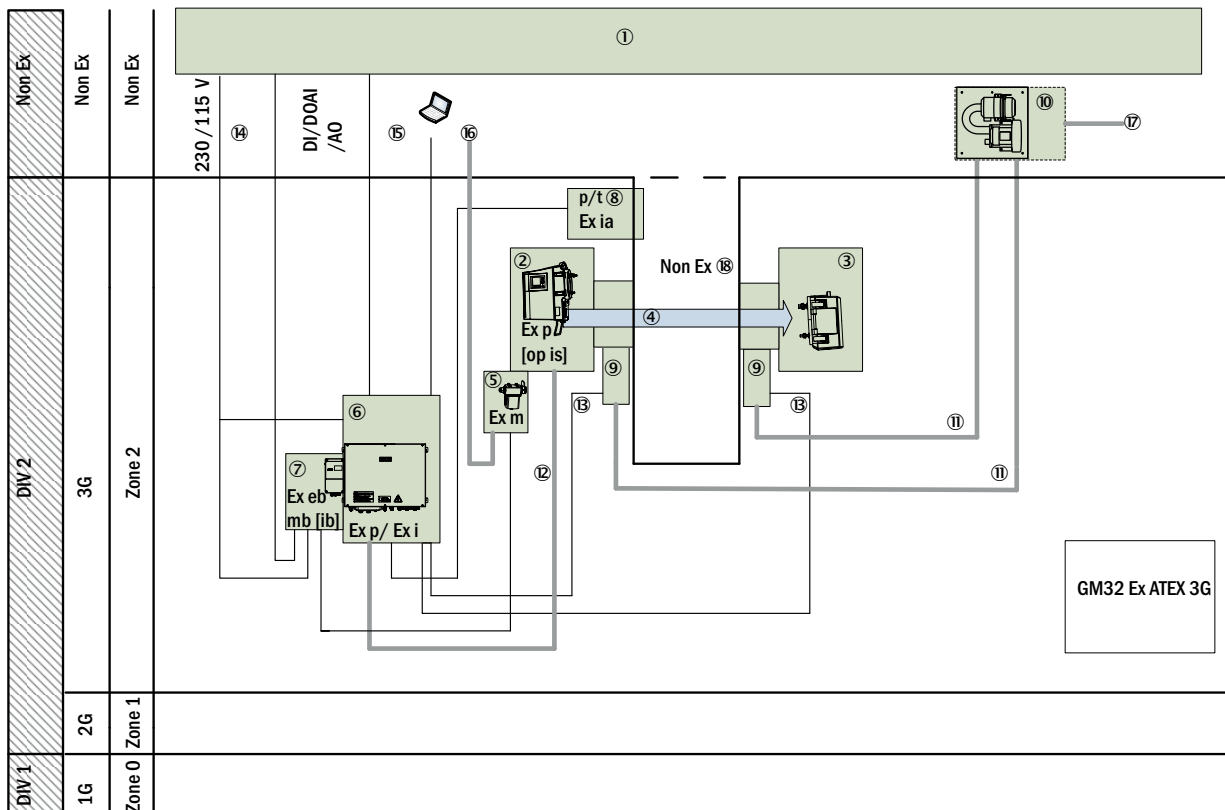

Figure 7: Zone separation GM32 Ex 3G

Components

- ① Control station / measuring station
- ② Sender/receiver unit
- ③ Reflector unit
- ④ Light source
- ⑤ Ex p valve
- ⑥ Evaluation unit
- ⑦ Overpressure control
- ⑧ p/T sensor
- ⑨ p sensor

- ⑩ Optics purge air according to plant operator's selection  
Lines
- ⑪ Purge air hose, optics
- ⑫ Connecting hose Ex p
- ⑬ Pressure controller, optics purge air Ex i nA
- ⑭ Ex p error case signal
- ⑮ Service interface
- ⑯ Feed, Ex p protective gas, provided by operator
- ⑰ Feed, optics purge air
- Measuring channel**
- ⑱ Measuring channel Ex-free; Zone 2 possible with partial vacuum

**3.10.2 Pressurized enclosure**

**Ignition protection type, pressurized enclosure for Zone 2**

**Purging**

All relevant enclosures of the sender/receiver unit and connection unit connected together via a pressure-proof metal hose are purged with a protective gas. This purging before the start of the device ensures any possibly present ignitable mixture is safely removed.

**Controlling the overpressure in the enclosure**

The control FS850P ensures the complete enclosure is held at an overpressure of at least 0.8 mbar against the atmosphere after the purging which in turn ensures no ignitable gas mixture can penetrate the enclosure.

**Protective gas types**

- Instrument air suctioned in from the area outside the potentially explosive atmosphere
- Inert gas

More information, see ["Technical data protective gas", page 96](#) and Pressurized Enclosure Operating Instructions.

**Alarm signal of the pressurized enclosure when a malfunction occurs**

Ex control unit FS850S for category 3G:  
Ex control unit FS850S will trigger an alarm signal when the pressurized enclosure is not in the correct operating state (malfunction).



**WARNING**

**Risk of explosion through incorrect parameter settings**

Unauthorized changing of parameters can cause an explosion with fatal consequences.

- ▶ Never change parameters without authorization.



**NOTICE**

The operating company is responsible for the evaluation of the alarm signal. See the Pressurized Enclosure System Manual.

### 3.11 Connecting hose between SR-unit and junction box

**The connection hose between the sender/receiver unit and the junction box**

- is part of the pressurized enclosure
- contains electrical connection lines
- is under overpressure

## 4 Transport and storage

### 4.1 Transport safety device

#### Removing the transport safety device of the SR-unit and the reflector unit

- 1 Open the lock and swivel the flange fixture up
- 2 Check the transport safety device for damage
- 3 Remove the transport safety devices (see Figure)
- 4 Store the transport safety device

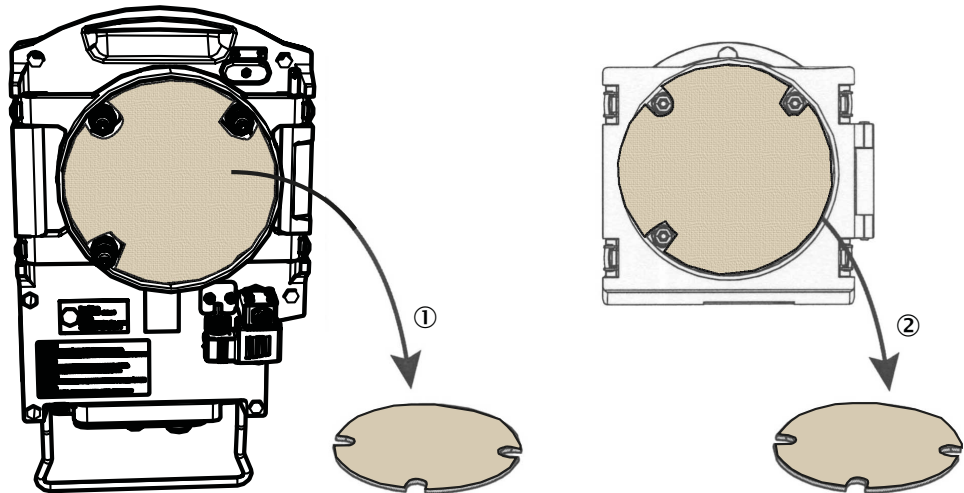

Figure 8: Remove the transport safety device

- ① Open the lock and swivel the flange fixture up
- ② Remove the transport safety device

### 4.2 Storage

- ▶ Clean all components of the measuring system with slightly damp cleaning cloths. Use a mild cleaning agent here.
- ▶ Check the desiccant cartridges and replace, if necessary.

After replacing the desiccant cartridges:

- ▶ Perform a leak tightness check.
- ▶ Protect the openings of the SR-unit and reflector unit from atmospheric influences, preferably with the original transport safety devices.
- ▶ Pack all components for storage or transport. Preferably use the original packing.
- ▶ Store all components of the measuring system in a dry, clean room.



#### NOTE

The check of the desiccant cartridges and of the leak tightness of the device is described in the Maintenance Chapter, see ["Check/replace the desiccant cartridge"](#), page 70.

## 5 Mounting

### 5.1 Information on installation in potentially explosive atmospheres

#### Project planning for measuring channel

---

**NOTICE**

Observe information in Chapter "Main operating information".

---

**NOTICE**

Hazard when exceeding the temperature classes for hot gas ducts

The temperature class T4 (max. 135 °C), for which the explosion protection of this device is designed, can be exceeded on hot gas ducts.

- ▶ Plan appropriate insulation of the duct and the flange during project planning/ assembly.
  - ▶ When necessary, ensure adequate ventilation or cooling.
- 

#### Correct installation

---

**DANGER**

**Risk for system safety through work on the device not described in these Operating Instructions**

Carrying out work on the device not described in these Operating Instructions or associated documents can lead to unsafe operation of the measuring system and therefore endanger plant safety.

- ▶ Only carry out the work on the device described in these Operating Instructions and associated documents.
- 

**DANGER**

**Risk of explosion through incorrect installation**

Incorrect assessment of the installation location as well as all further installation work in potentially explosive atmospheres can cause serious injuries to people and damage during operation.

- Installation, commissioning, maintenance and inspection may only be carried out by skilled persons having knowledge of the relevant rules and regulations for potentially explosive atmospheres, especially:
    - Ignition protection types
    - Installation regulations
    - Zone classification
  - Standards to be applied:
    - IEC 60079-14, Annex F: Knowledge, skills and competencies of responsible persons, operatives and designers
    - IEC 60079-17: Electrical installations inspection and maintenance
    - IEC 60079-19: Equipment repair, overhaul and reclamation
  - Local work safety regulations
-



**WARNING****Risk of injury when the device drops down**

The weight of the device can cause it to drop down and cause injuries during the work described in this Chapter.

- ▶ Carry out assembly work on parts of the device together with another person when necessary.

**Purge air****DANGER****Risk of explosion through suctioning optics purge air from an Ex zone**

Zone separation is no longer ensured when the purge air supply to purge the optics is suctioned in within the Ex zone. This can lead to an explosion.

- ▶ Always make sure the air for the purge air supply is suctioned in from an Ex free zone.

## 5.2 Preparing the sampling point

### The operator is responsible for preparing the sampling point

**NOTICE**

Basis for determining the sampling point:

- Preceding project planning (e.g., based on the SICK application questionnaire)
- Regulations of the local authorities

Responsibility of the operator

- Determine sampling point
- Preparing the sampling point
- Feed and drain for protective gas

**DANGER****Risk of explosion through suctioning optics purge air from an Ex zone**

Zone separation is no longer ensured when the purge air supply to purge the optics is suctioned in within the Ex zone. This can lead to an explosion.

- ▶ Always make sure the air for the purge air supply is suctioned in from an Ex free zone.

**NOTICE**

Observe zone separation, see "[Zone separation GM700 EX ATEX 3G](#)".

## 5.3 Scope of delivery

**NOTICE**

- ▶ Check the scope of delivery according to the order confirmation/delivery note.

### 5.3.1 Checking the delivery state



#### NOTICE

- ▶ Check all components have no exterior damage.
- ▶ Ensure the supply voltages on the type plates match the plant conditions.

## 5.4 Installation sequence

### 5.4.1 Overview of the installation steps (duct-side preparation)

Step	Procedure	Reference
1	Installing the flange with tube.	see "Install flanges with tube", page 26.
2	Installing the connection unit.	see "Installing the connection unit", page 28.
3	Fitting the purge air unit or units.	see "Installing the purge air unit", page 30.
4	Observing protective gas discharge line (connection unit).	see "Fitting the FS850S", page 29.
5	Connecting pressure, temperature and purge air monitor.	see "Connecting pressure, temperature and purge air monitor", page 40.
6	Connecting protective gas feed to SR-unit.	see "Connecting the protective gas on the SR-unit", page 50.

### 5.4.2 Install flanges with tube



#### DANGER

##### Hazard through hot, explosive or toxic flue gases

Hot and/or noxious gases can escape during assembly work on the gas duct depending on the plant conditions.

- ▶ Work on the gas duct may only be performed by skilled persons who, based on their technical training and knowledge as well as knowledge of the relevant regulations, can assess the tasks given and recognize the hazards involved.



#### DANGER

##### Hazard through hot, toxic and corrosive flue gases

Hot and/or noxious gases can escape during assembly work on the gas duct depending on the plant conditions.

- ▶ Switch the plant off when working on the gas duct  
or
- ▶ the operator determines the safety measures to be observed during work on the plant when switched on.



#### CAUTION

##### Device damage through incorrect/missing insulation of the duct when the measuring channel is hot

- ▶ When the measuring channel is hot, plan the duct and flange insulation so that the device is protected against high temperatures.

### Installing the flange with tube on the gas duct

- 1 Cut openings on the gas duct for the flange with tube.
- 2 Insert the flange with tube. Pay attention to the following:
  - The "Top" marking must point upwards vertically, irrespective of the gas duct angle.
  - The tube must project at least 30 mm into the gas duct.

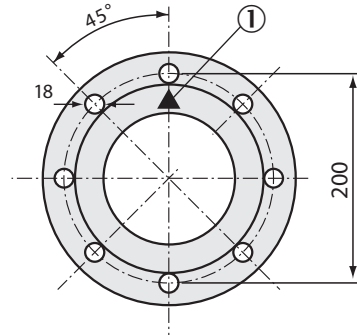

Figure 9: "Top" marking on flange with tube

- ① "Top" marking

- 3 Attach the flange with tube.



#### NOTE

Make sure other devices or installations do not intersect or interrupt the beam path of the measuring device.

- 4 Cut the flange opening for the reflector unit accordingly. Caution: Deviation of tube axis between SR-unit and reflector unit: Max. 1°.

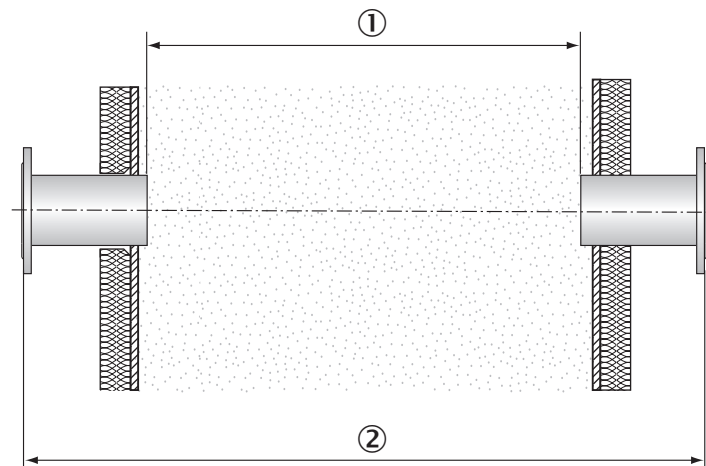
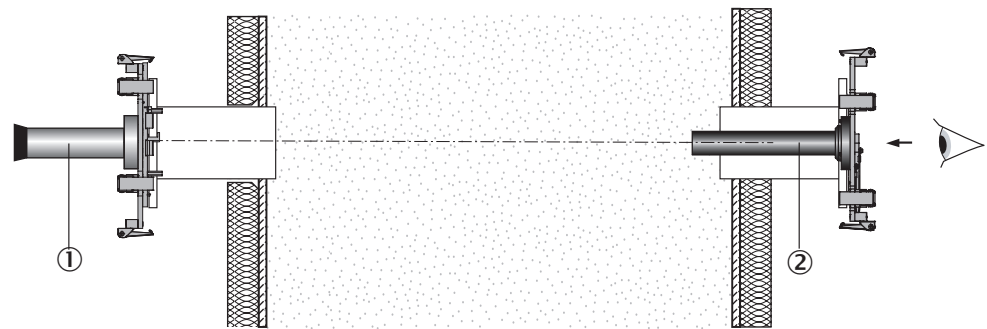

Figure 10: Define the measuring path

- ① Active measuring path
- ② Active measuring path "flange - flange"
- 4 Align the flange visually
  - ▷ Remove the protective cap from the adjustment tube.
  - ▷ Install the adjustment device (light source on SR-unit side, adjustment tube on reflector side) onto the flanges.



- ① Light source
- ② Adjustment tube



**NOTE**

The alignment is performed on the flange where the adjustment tube is located.

- Look in the window of the adjustment tube and focus the light spot of the light source by shifting the optical beam tube.
- Alignment: The light spot must be shown centrally in the target of the adjustment tube.

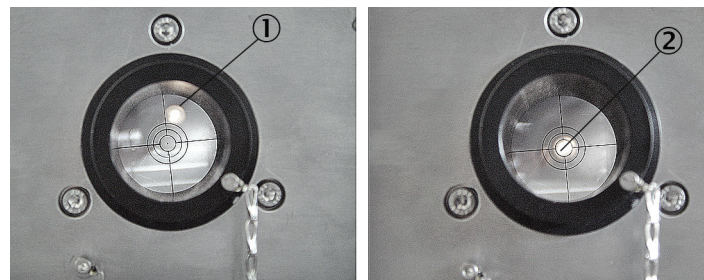

- ① Not aligned correctly
  - ② Aligned correctly
- 5 Attach the flanges with tube on the gas duct.



**NOTICE**

In doing so, the alignment of the flanges may not be changed!

- 6 Perform the check:
  - Active measuring path dimension
  - Flange - flange dimension
  - Alignment
- 7 Remove the adjustment device again.
- 8 If necessary, attach duct insulation to protect the measuring device from heat.

**5.4.3 Installing the connection unit**

The lengths of the lines to the sender/receiver unit match the project planning.

- ▶ Install the connection unit using the 4 threaded bolts according to project planning.



**NOTE**

Dimension drawings of the connection unit and specifications on screw fittings for the lines, see "[Dimension drawings: Connection unit version 3G](#)", page 95.

### 5.4.3.1 Fitting the FS850S

#### Information on fitting

When setting up outdoors, it is recommended to protect the explosion-proof device against direct atmospheric influences, e.g. with a protective roof.

The fitting position is independent of the location but it should be ensured that the protective gas inlet and outlet are in a horizontal axis

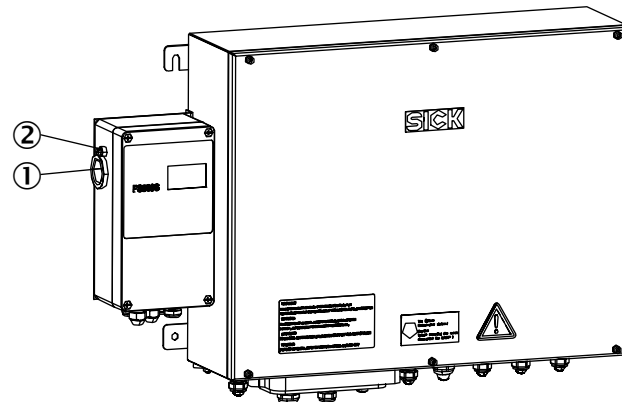

Figure 11: Protective gas outlet

- ① Protective gas outlet: Thread G 1"
- ② Reference opening (M5 inner thread)

#### Protective gas quality

- Instrument air or inert gas
- Compressed air, class 533 according to ISO 8573-1
- Solid matter 40  $\mu\text{m}$  (class 1)
- Pressure dew point  $\leq 20$  °C (class 3)
- Oil quality  $\leq 0.01$  mg/m<sup>3</sup> (class 1)

The air quality may possibly have to be better depending on the requirements of the devices fitted in the pressurized enclosure.

#### Protective gas outlet

It is important that protective gas can flow out of the protective gas outlet against the atmospheric pressure.

- Ensure the unhindered flow of the protective gas.

#### Reference opening

The reference opening must be located in the Ex area.

- Make sure the opening is always clear.

#### Line lengths for protective gas supply

Large pressure losses occur during the purge phase (high purge medium throughput) depending on the supply line diameter. Consider this when dimensioning the supply line:

Reference values: With 4 mm line diameter (inner diameter), a pressure loss of 500 mbar per meter must be calculated during purging with 2 l/s.

Pressure losses are apparent due to the purge medium throughput being too low and lead to a longer or never-ending purge phase.

**NOTE**

More information on protective gas,

- see "Connecting the Ex overpressure control FS850S", page 41.
  - see "Technical data protective gas", page 96.
- 

### 5.4.4 Installing the purge air unit

---

**NOTE**

Purge air hose to the device according to project planning.

---

**NOTE**

For information on installing the purge air unit, see the Operating Instructions of the purge air unit.

---

#### 5.4.4.1 Start-up of the purge air supply

---

**CAUTION****Risk of device damage caused by inadequate purge air pressure**

The purge air supply protects the measuring system from contamination and overheating. If the purge air pressure is inadequate, the purge air can not enter the gas duct. This can result in inadequate provision with purge air and therefore a device failure.

- ▶ Ensure the purge air pressure is adequate to force the purge air into the gas duct.
  - ▶ If you have questions concerning the purge air pressure, contact SICK Customer Service or your local SICK representative.
- 

**CAUTION****Risk of device damage through accidentally switching off the power supply**

The purge air supply may not be switched off while the measuring system is on the gas duct.

- ▶ Attach clearly visible warnings against accidental switching-off to all switching devices where the purge air supply can be switched off.
-

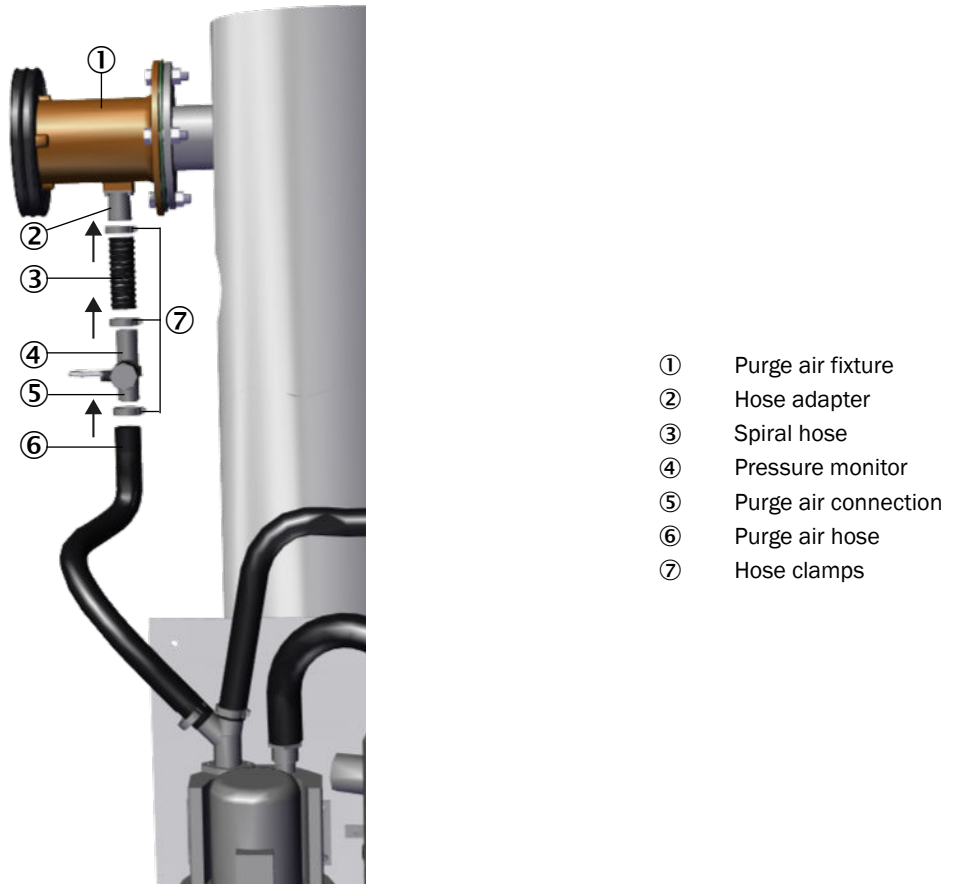

Figure 12: Installing the GM32 purge air unit

Preparing the purge air unit:

- 1 Switch the power supply of the purge air unit on at the disconnecting device (fitted by the operator) for the purge air unit
- 2 Check the function of the purge air unit: A strong air flow must be noticeable.



**NOTE**

Clarify the cause when no strong air flow is noticeable. Refer to Purge Air Unit Operating Instructions.

- 3 Blow out any dust that may have entered the purge air hose.
- 4 Switch the power supply off again.

Connecting the purge air supply:

- 1 Pull the spiral hose over the hose adapter (top) and pressure monitor connection (bottom) and secure each with a hose clamp.
- 2 Pull the purge air hose over the purge air connection of the differential pressure sensor and secure with a hose clamp.
- 3 Switch the power supply of the purge air unit on again.

## 6 Electrical installation

### 6.1 Electrical installation safety information

#### Electrical safety

---



#### WARNING

**Endangerment of electrical safety during installation and maintenance work when the power supply is not switched off**

- ▶ Before starting the work on the device, ensure the power supply can be switched off using a power disconnecter switch/circuit breaker in accordance with DIN EN 61010-1.
  - ▶ Make sure the power disconnecter switch is easily accessible.
  - ▶ An additional disconnecting device is mandatory when the power disconnecter switch cannot be accessed or only with difficulty after installation of the device connection.
  - ▶ After completion of the work or for test purposes, the power supply may only be activated again by authorized personnel complying with the safety regulations.
- 



#### WARNING

**Endangerment of electrical safety through power cable with incorrect rating**

Electrical accidents can occur when the specifications for replacement of a power line have not been adequately observed.

- ▶ Always observe the exact specifications in the Operating Instructions (Technical Data Section) when replacing a power line.
- 



#### DANGER

**Danger of electrical accidents**

Incorrect performance of electrical work could result in serious electrical accidents.

- ▶ Only let the work described in the following be carried out by electricians familiar with potential hazards.
- 



#### CAUTION

**Hazard of device damage**

Electronic components are accessible when the enclosure is open. The circuit board can be severely damaged when a contact is not grounded when the power supply is switched on.

- ▶ First switch the power supply on when the sender/receiver unit and the control unit are closed.
- 



#### CAUTION

**Device damage through short circuit on the device**

The internal electronics can be damaged when signal connections are established and the power supply is switched on. This is also valid for plug connections.

- ▶ Disconnect the GM32 Ex and any connected devices from the voltage supply.
-



---

**Ex information**

---

**DANGER****Risk of explosion through incorrect performance of maintenance work**

Incorrect performance of maintenance work in potentially explosive atmospheres can cause serious injuries to people and damage during operation.

- Maintenance work and start-up activities as well as checks must be performed by experienced/trained technicians having knowledge of the relevant rules and regulations for potentially explosive atmospheres, especially:
    - Ignition protection types
    - Installation procedures
    - Zone classification
  - Standards to be applied:
    - IEC 60079-14, Annex F: Knowledge, skills and competencies of responsible persons, operatives and designers
    - IEC 60079-17: Electrical installations inspection and maintenance
    - IEC 60079-19: Equipment repair, overhaul and reclamation
- 

**WARNING****Risk of explosion**

Some of the work described in this Chapter assumes an Ex free zone.

- ▶ Wait 20 minutes after switching off the main power supply before opening the enclosure.
- 

**WARNING****The Ex certification becomes void when line inlets and plugs without approval are used**

The line inlets and plugs are part of the Ex protection and therefore require approval.

- ▶ Do not replace line inlets or plugs with other types.
  - ▶ Line inlet dimensions, see "[Dimension drawings: Connection unit version 3G](#)", page 95.
- 

**DANGER****The Ex certification becomes void when line inlets and plugs without approval are used**

The line inlets and plugs are part of the Ex protection and therefore require approval.

- ▶ Do not replace line inlets or plugs with other types.
  - ▶ Line inlet dimensions, see "[Dimension drawings, evaluation unit with enclosure pressurization system FS840](#)".
- 

**DANGER****Risk of explosion through non-Ex conform installation of the lines to the device**

Incorrect installation of the supply lines (power supply, signal and communication lines) through Ex zones can lead to an electrostatic charge. This creates an increased risk of explosion.

- ▶ Install all lines in accordance with EN61010-1 and EN60079-14.
  - ▶ Protect lines against electrostatic charges.
-



**DANGER**

**Risk of explosion through incorrect connection of the external sensors**

The explosion protection is endangered when the external sensors p/T (in the stack) as well as the optics purge air monitor (on the purge air fixture) are not connected to the intrinsically safe terminals provided in the connection unit.

- ▶ Always connect the external sensors p/T (in the stack) as well as the optics purge air monitor (on the purge air fixture) to the intrinsically safe terminals specified in the connection unit for this purpose.
- ▶ Observe the intrinsically safe connection values for the Ex barriers fitted in the evaluation unit in the Operating Instructions delivered.



**DANGER**

**Risk of explosion through unsuitable screw fittings and lines**

- ▶ Only use lines (according to EN60079-14) with suitable outer diameters.
- ▶ Close off cable inlets “vapor-proof” (virtually gas-tight).
- ▶ Protect lines against electrostatic charges.
- ▶ Only open those cable inlets to be used for installing cables. Keep the plugs. Refit the original plug when a cable inlet must be closed again afterwards.

6.2 Connection overview

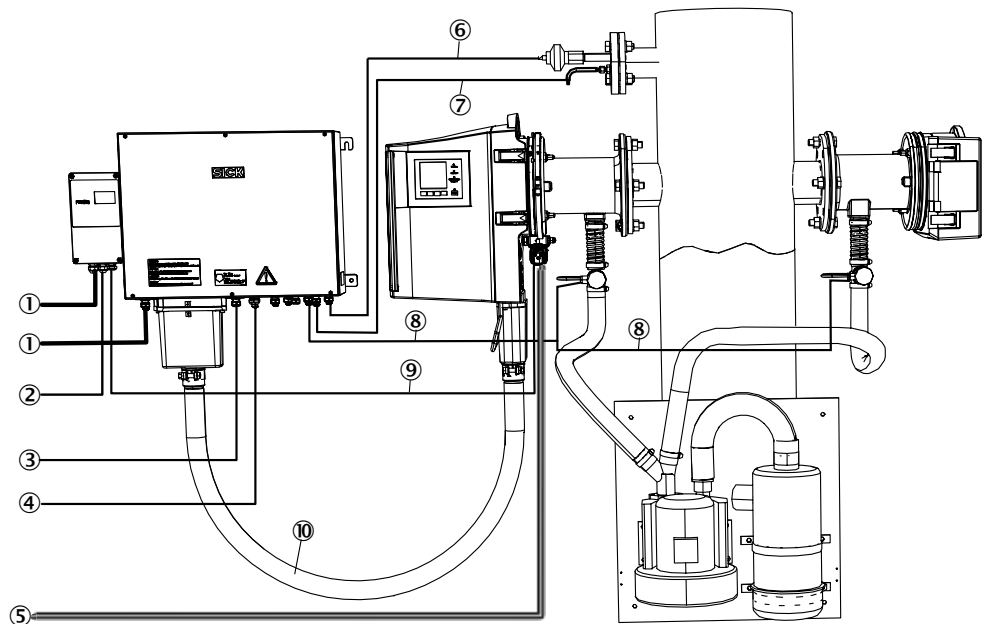

Figure 13: Overview of electrical connections GM32 Ex 3G / Zone 2

- ① Power supply 115 V / 230 V
- ② Warning signal Ex-p control
- ③ Fiber optics (Ethernet)
- ④ I/O signal lines
- ⑤ Protective gas supply
- ⑥ Connection line, pressure sensor
- ⑦ Connection line, temperature sensor
- ⑧ Connection line, purge air monitor, pressure switch
- ⑨ Connection line, purge valve SVP3 G3G 8"-300L EEx p

- ⑩ Metallic connecting hose between sender/receiver unit and connection unit

### 6.2.1 Lines

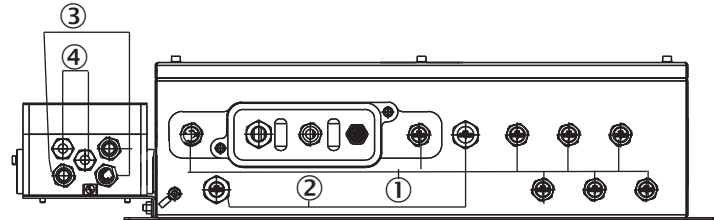

Figure 14: Connection unit version 3G (all specifications in mm)

No.	Line opening size	Line diameter (clamping range)	Number
①	M16 x 1.5	5 - 11 mm	8
②	M20 x 1.5	10 - 14 mm	2
③	M16 x 1.5	5 - 11 mm	3
④	M16 x 1.5	4 - 8 mm	2

Lines	Remark
Connection unit – sender/receiver unit with connecting hose	In accordance with project planning: <ul style="list-style-type: none"> <li>• 5 m</li> <li>• 10 m</li> </ul>
Differential pressure sensor – connection unit	On-site, intrinsically safe I/O connection
Pressure/temperature input	On-site, intrinsically safe I/O connection
Ethernet PC/network (fiber optics)	On-site, fiber optics
Inputs/outputs	On-site: Terminal connection
Connection unit – SCU-P100 (CAN cable)	On-site

Table 4: Technical data, M screw fittings

Outer thread	M20 x 1.5	M16 x 1.5
Thread length	6 mm	
H	23 mm	
Cable diameter	10 ... 14 mm	6 ... 10 mm
Key width	24 mm	20 mm
Continuous service temperature	-20 ... 95 °C	
Material	Nickel-plated brass	

## 6.3 Connecting interfaces

### 6.3.1 Connecting I/O interfaces (option)



#### CAUTION

Never lay power supply cables directly next to signal cables.



**DANGER**

**Risk of explosion when laying the I/O lines**

It is possible that the I/O lines have to be laid within the Ex zone. There is a risk of explosion when signals are accessed unprotected within the Ex zone.

- ▶ Carry out wiring work under increased safety.
- ▶ Do not access the I/O signals in the Ex zone unprotected.
- ▶ Protect lines against electrostatic charges.

- 1 Route the data lines through the M screw fittings.
- 2 Connect the data line.



**NOTE**

Description of I/O modules, see Operating Instructions Modular I/O System.

6.3.1.1 Connection diagram for variant 3G

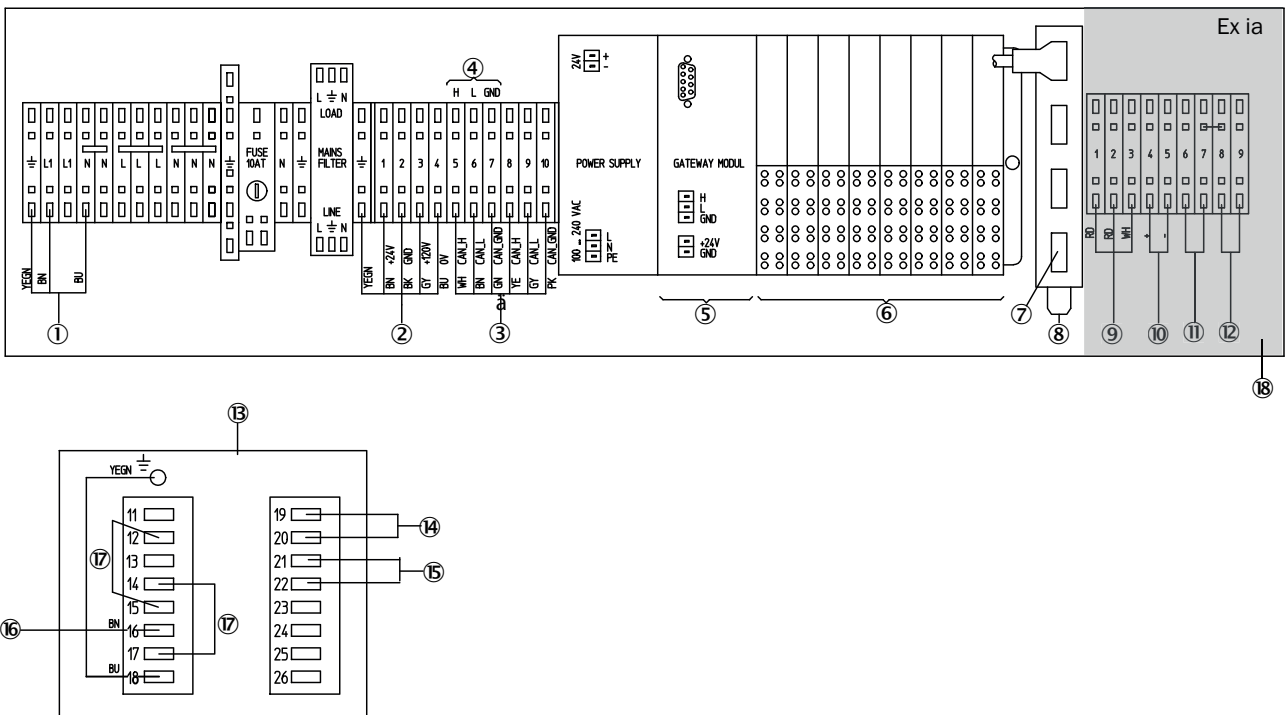

Figure 15: Connection diagram of connection unit for variant 3G / Ex zone 2

- ① Power supply 100 - 240 V /50 - 60 Hz
- ② Power supply GM32
- ③ CAN GM32
- ④ CAN to EvU /SCU
- ⑤ Gateway module
- ⑥ I/O module
- ⑦ Ethernet bus
- ⑧ Fiber optics connection
- ⑨ Connections of temperature sensor (3-wire circuit): Pins , 1,2 and 3
- ⑩ Connections of pressure sensor: Pins 4 and 5
- ⑪ Pressure controller for purge air monitor, sender: Pins 6 and 7
- ⑫ Fit a bridge between pins 8 and 9
- ⑬ Ex-p control unit
- ⑭ Connection, Ex p valve
- ⑮ Status signal output (contact closed currentless)
- ⑯ Power supply of control unit
- ⑰ Fitted bridges (by manufacturer)
- ⑱ Connection area for intrinsically safe components

**EX NOTICE**

In area ⑰, the intrinsically safe connections for temperature ⑨, pressure ⑩ and two digital inputs ⑪ + ⑫ to connect the pressure controller are provided. Only connect intrinsically safe simple operating means with suitable connection data to these terminals in accordance with the Table below. Otherwise the explosion protection of the connected sensors is not ensured.

- Only connect intrinsically safe devices with suitable connection data to these terminals.

Table 5: Connection data for intrinsically safe connections

Terminal	Inlet sizes	Gas group	Uo	Io	Po	Ui	Ci <sup>1</sup>	Li	Co <sup>3</sup>	Lo <sup>4</sup>	μH/ Ω
1	Inlet, temperature sensor PT100, 3-wire circuit RMA42	IIC	≤ 27.3 V	≤ 22.1 mA	151 mW	k.A.	8 nF	75 μH	≤ 85 nF	≤ 500 μH	k.A.
2		IIB							≤ 360 nF	≤ 2 mH	k.A.
3		IIB							≤ 530 nF	≤ 5 mH	k.A.
4	Analog input, pressure sensor 4-20 mA RMA42	IIC	≤ 27.3 V	≤ 96.5 mA	659 mW	k.A.	8 nF	75 μH	≤ 88 nF	≤ 4 mH	k.A.
5		IIB							≤ 683 nF	≤ 17 mH	k.A.
		IIA							≤ 2 280 nF	≤ 34 mH	k.A.
6	Digital input, pressure switch 1 KCD2-SR-Ex	IIC	10.5V	17.1m A	45m W	12 V	0	0	2.41 μF	≤ 121.5 mH	801
7		IIB							≤ 16.8 μF	≤ 486.3 mH	1628
		IIA							≤ 75 μF	≤ 972.7 mH	1628
8	Digital input, pressure switch 2 KCD2-SR-Ex	IIC	10.5V	17.1m A	45m W	12 V	0	0	≤ 2.41 μF	≤ 121.5 mH	801
9		IIB							≤ 16.8 μF	≤ 486.3 mH	1628
		IIA							≤ 75 μF	≤ 972.7 mH	1628

- 1 Max. inner capacity
- 2 Max. inner inductivity
- 3 Max. outer capacity
- 4 Max. outer inductivity
- 5 L/R ratio (inductivity/resistance)

6.3.1.2 Default values for interfaces

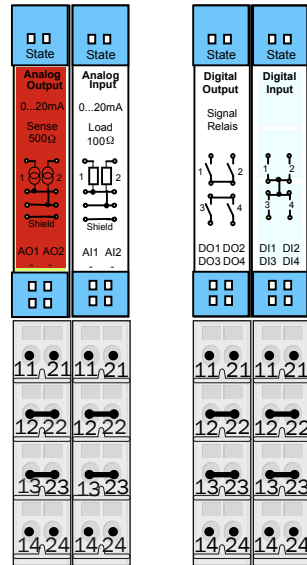

Figure 16: Example: I/O module pin assignment

Analog input	Pin assignment	Function
AI 1	11, 12	Temperature (internally wired)
AI 2	21, 23	Pressure (internally wired)
AI 3	11, 12	Humidity



**NOTE**

The analog input assignment shown in the Table is the default setting. The assignment of the inputs can be freely configured with SOPAS. For more information, see the SOPAS Operating Instructions.

Analog output	Pin assignment	Function
AO1	11, 12	User-specific
AO 2	21, 23	User-specific

Digital output	Pin assignment	Function
DO 1	11, 12	Failure
DO 2	21, 22	Maintenance_Request
DO 3	13, 14	Not_measuring
DO 4	23, 24	Output_control_values
DO 5	11, 12 <sup>1</sup>	Uncertain
DO 6	21, 22 <sup>1</sup>	Extended
DO 7	13, 14 <sup>1</sup>	Purge_air_failure
DO 8	23, 24 <sup>1</sup>	No_function
Configurable	Configurable	Measuring range switch-over (see GM32 Technical Information)

<sup>1</sup> On second module

Digital input	Pin assignment	Function
DI 1	11, 12	Check_cycle
DI 2	21, 22	Maintenance
DI 3	13, 14	Output_control_values
DI 4	23, 24	Disable_check_cycle
DI 5	11, 12 <sup>1</sup>	Purge_air_status
DI 6	21, 22 <sup>1</sup>	--
DI 7	13, 14 <sup>1</sup>	--
DI 8	23, 24 <sup>1</sup>	--

<sup>1</sup> On second module



#### NOTE

##### Information concerning the customer-specific module assignment

- The module layout from the left to the right always has the sequence: AO-AI-DO-DI
- The number of inlets and outlets is defined:
  - AO: 2x
  - AI: 2 x
  - DO: 4 x
  - DI: 4 X
- Second measuring range: AO is always on the right next to the respective component.

## 6.4 Connecting the connection hose to the SR-unit on the junction box



#### NOTICE

The connecting hose between the SR-unit and the junction box is part of the pressurized enclosure. It is under overpressure.

- ▶ Protect the connecting hose from possible damage.

- 1 Lead the cable through the 2 M screw fittings, see Figure below.
- 2 Plug in the M12 Ethernet connector and screw tight, see Figure below.
- 3 Connect the cables in the connection unit, see ["Preparing the power supply"](#), page 43.
- 4 Screw the M4 screws tight.
- 5 Push on the connector housing and screw tight.

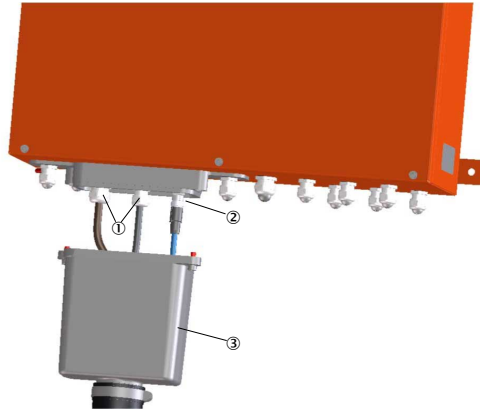

Figure 17: Connecting hose SR-unit/connection unit

- ① 2 M screw fittings
- ② Ethernet connector
- ③ Connector housing

### 6.5 Connecting pressure, temperature and purge air monitor



#### NOTE

Purge air monitor - pressure controller for purge air monitoring

- Wiring diagram, see ["Connection overview"](#), page 34
- Terminal assignment, see ["Connection diagram for variant 3G"](#), page 36.
- Observe the Operating Instructions of the sensors and the purge air monitor.

### 6.6 Connecting the potential equalization on the purge air fixture

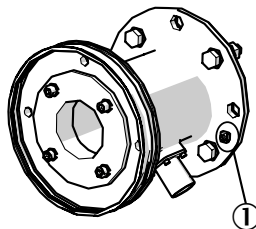

Figure 18: Potential equalization on the purge air fixture

- ① Connection of potential equalization
- ▶ Screw the grounding conductor tight on the screw terminal.



## 6.7 Connecting the Ex overpressure control FS850S

### Electrical safety

---



#### WARNING

##### Risk of injury through electric voltage

Switch the power supply off before working on terminals and laying lines.

- ▶ Observe the installation regulations according to VDE DIN 57 165 and Test Certificate BVS 06 ATEX E088.
- 

### Risk of explosion

---



#### DANGER

##### Risk of explosion through incorrect settings for the pressurized enclosure

The pressurized enclosure is a central safety part of the device. All work is described in this Manual and the relevant specified documents. If work is performed which is not described in this Manual, the risk of explosion of the measuring system increases and the ATEX certification for the device becomes void.

- ▶ Carry out all work skillfully and in accordance with the delivered documentation.
- 

### Unsafe measuring operation

---



#### CAUTION

##### Risk of unsafe measuring operation through loss of degree of protection IP64

Ineffective seals of the connection unit and insufficient closed openings for unused line inlets can lead to loss of degree of protection IP64. Penetration by dust or moisture can lead to unsafe operation of the FS850S.

- ▶ Close off unused openings for line inlets with impact resistant sealing plugs that have been checked against self-loosening and turning.
  - ▶ Check the seals on the Ex-e enclosure for damage and replace as necessary.
  - ▶ Tighten the terminals, especially in the Ex-e area.
  - ▶ Check the terminals for discoloration. This could indicate increased temperatures.
  - ▶ Check the gland screw fittings, sealing plugs and flanges for leak tightness and tight seat.
-

Terminal assignment

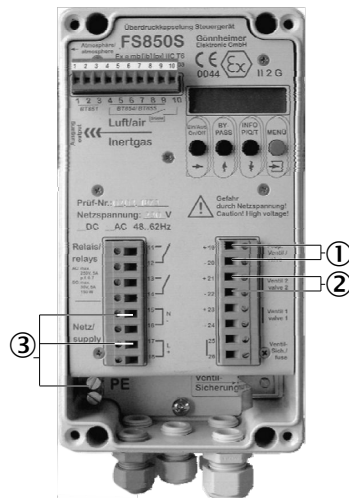

Figure 19: Connecting the Ex overpressure control

- ① Connection, Ex p valve
- ② Status signal output
- ③
  - N on terminal 15
  - L1 on terminal 17
  - PE

Table 6: Terminals with higher safety in the FS850S

Tightening torque	Wire cross-section rigid / flexible
Min. 0.3 Nm	Min. 0.3 mm <sup>2</sup>
Max. 0.4 Nm	Max. 2.5 mm <sup>2</sup>

Always maintain the limit values on the respective terminals. Refer to the Technical Data or the Test Certificate for the limit values. The fitted valve safeguard must correspond to the specified safeguard value of the purge medium valve used.



**NOTE**

Further information on the pressurized enclosure system, see "[Pressurized enclosure system settings](#)", page 97 and FS8505 Operating Instructions.

6.8 Electrical connection of SR-unit



**NOTICE**

The connecting hose between the SR-unit and the junction box is part of the pressurized enclosure. It is under overpressure.

- ▶ Protect the connecting hose from possible damage.

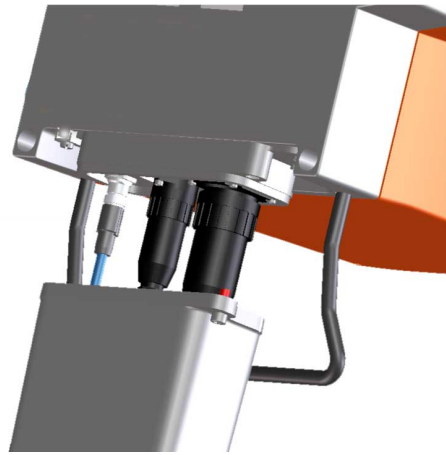

Figure 20: Connection of connecting hose with the SR-unit

#### Connecting the connecting hose to the SR-unit

- 1 Plug the three connectors of the connecting hose to the SR-unit.
- 2 Push on the cover and screw tight.



#### NOTE

Connection diagram, see ["Connection overview"](#), page 34.

## 6.9 Preparing the power supply



#### CAUTION

##### Prevent accidentally switching off the optics purge air supply

Accidentally switching off the optics purge air supply can cause the measuring system to contaminate and overheat.

- ▶ Attach a clearly visible warning against accidentally switching off the separation equipment for the purge air unit.

- 1 Check that the connection lines meet the requirements:
  - Cross-section: 3 x 1.5 mm<sup>2</sup>
  - Temperature class: -40 ... +85 °C
- 2 Provide a separate external disconnecting device for:
  - Connection unit (max. power input [page 91](#)).
  - Purge air units (see Technical Data of purge air unit).
  - Mark the disconnecting device as disconnecting device for the GM32 Ex.
  - ▷ Route the power cable through the M screw fitting.
  - ▷ Connect the lines in the connection unit.
- 3 Screw M screw fittings tight.

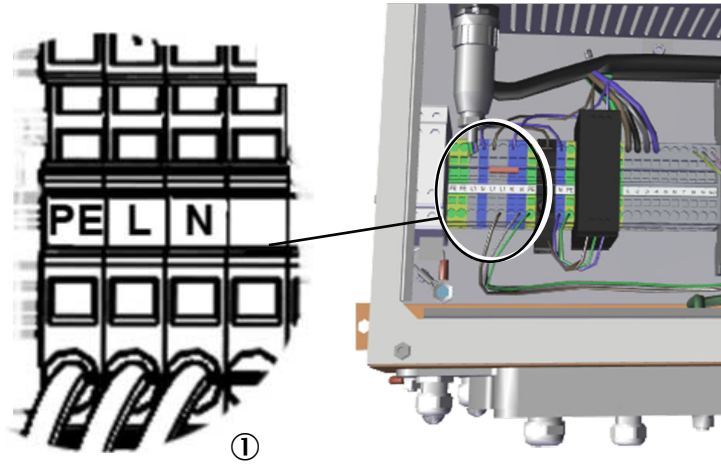

Figure 21: Power connection in connection unit for version 3G

- ① Power supply 100 ... 230 V / 50 .. 60 Hz



**NOTICE**

Always connect a protective conductor to PE.

### 6.10 Connecting the potential equalization to the SR-unit

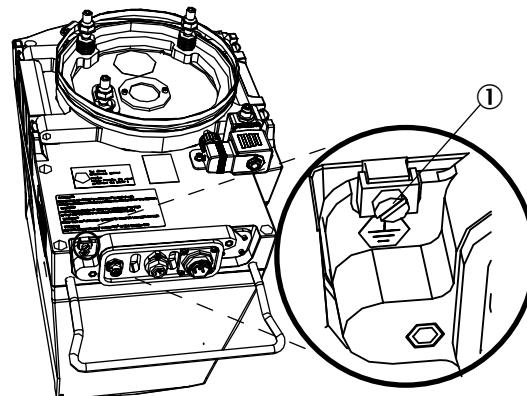

Figure 22: Connecting the potential equalization on the SR-unit

- ① Potential equalization connection

- ▶ Screw the grounding conductor (4 mm<sup>2</sup>) of the equipment ground tight to the screw terminal.

## 7 Commissioning

### 7.1 Safety information for start-up

Technical knowledge needed / requirements for commissioning



#### NOTICE

- You are basically familiar with the GM32.
- You are familiar with the national and local requirements regarding setting up and operating devices in potentially explosive atmospheres.
- You are familiar with the local situation, especially the potential hazards caused by gases in the gas duct (hot/noxious). You are capable of recognizing and preventing danger by possibly escaping gases.

If one of these requirements is not met:

- ▶ Please contact SICK Customer Service or your local representative.

#### Gas



#### DANGER

##### Danger to life by leaking hot/toxic gases

Hot and/or noxious gases can escape during work on the gas duct, depending on the plant conditions.

- ▶ Work on the gas duct may only be performed by skilled technicians who, based on their technical training and knowledge as well as knowledge of the relevant regulations, can assess the tasks given and recognize the hazards involved.



#### DANGER

##### Damage to eyes and skin by UV radiation

The in-situ gas measuring device GM32 emits UV radiation when the SR-unit or reflector unit is opened during operation. Exposure of the unprotected skin and eyes to radiation is dangerous to health.

- ▶ Disconnect the power supply of the device before opening the device.
- ▶ Wear suitable protective goggles and protective gloves when work on the open device with the power supply connected is performed.



#### WARNING

##### Risk to health through contact with toxic gases

The modules and equipment contain enclosed, potentially dangerous gases that can escape should a defect or leak occur. Should a leak occur, the concentrations within the enclosed equipment can rise up to 40 ppm.

- NO: 2 ml maximum total volume
- ▶ Only open the device when good ventilation is available, especially when a leak of one of the device components is suspected.

#### Grounding



#### CAUTION

##### Device damage through incorrect or missing grounding

It must be ensured during installation and maintenance work that the protective grounding of the device or lines involved is established in accordance with EN 61010-1.

## System safety

**ATTENTION****Responsibility for the safety of a system**

The person setting the system up is responsible for the safety of the system in which the device is integrated.

## 7.2 Material required

Not included in the scope of delivery!

Material required	Part No.	Required for
Optical adjusting device	2034121	Aligning the purge air fixtures
19 mm open-end wrench		Aligning the flanges
Optical cleaning cloth without detergents	4003353	Cleaning the window
Personal protective equipment		Protection when working on the stack or hot or aggressive sample gases

## 7.3 Check before start-up

**Before every start-up**

- ▶ Check that all enclosures are closed
  - Enclosure cover
  - Cable inlets
  - Enclosure openings
- ▶ Ensure the permanent feed of protective gas, see ["Connecting the Ex overpressure control FS850S", page 41.](#)

## 7.4 Overview of start-up steps

Step	Procedure	Reference
1	Removing the transport safety devices.	see <a href="#">"Transport safety device", page 23.</a>
2	Fitting the purge air fixtures on the "flange with tube".	see <a href="#">"Fitting the purge air fixtures on the flange with tube", page 47.</a>
3	Installing the device flange on the purge air fixture.	see <a href="#">"Installing the device flange on the purge air fixture", page 47.</a>
4	Aligning the device flanges and purge air fixtures.	see <a href="#">"Aligning device flanges and purge air fixtures", page 49.</a>
5	Connecting the protective gas.	see <a href="#">"Connecting the protective gas on the SR-unit", page 50.</a>
6	Connecting the potential equalization.	see <a href="#">"Connecting the potential equalization to the SR-unit", page 44,</a> see <a href="#">"Connecting the potential equalization on the purge air fixture", page 40.</a>
7	Electrical connection of SR-unit and reflector unit.	see <a href="#">"Electrical connection of SR-unit", page 42.</a>
8	Start-up of the purge air supply.	see <a href="#">"Start-up of the purge air supply", page 30.</a>
9	Installing the SR-unit and reflector unit on the device flange.	see <a href="#">"Installing the SR-unit and reflector unit on the device flange", page 52.</a>
10	Optical fine alignment of the SR-unit.	see <a href="#">"Optical fine alignment of the SR-unit", page 52</a>

Step	Procedure	Reference
11	Installing weatherproof covers (option).	see "Fitting the weatherproof cover (option)", page 53.

## 7.5 Fitting the purge air fixtures on the flange with tube



### NOTE

Installation of the purge air fixtures on the SR-unit and on the reflector is identical.

- Install the purge air fixture according to the Figure.

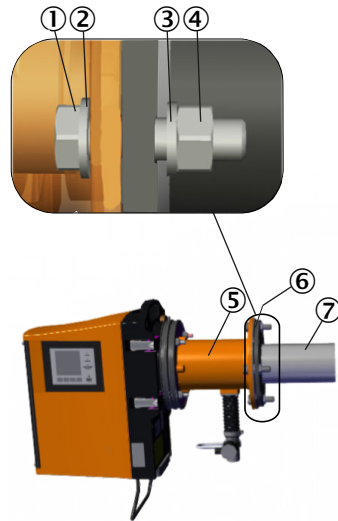

Figure 23: Fitting the purge air fixtures on the flange with tube

- ① Screw
- ② Washer
- ③ Spring sheet
- ④ Nut
- ⑤ Purge air fixture
- ⑥ Flange seal
- ⑦ Flange with tube

## 7.6 Installing the device flange on the purge air fixture



### NOTE

Installation of the purge air fixtures on the SR-unit and on the reflector is identical.



### NOTE

Installation is easier when the SR-unit is taken off the device flange before installation, see "Swiveling out and removing the SR-unit or reflector unit", page 68.

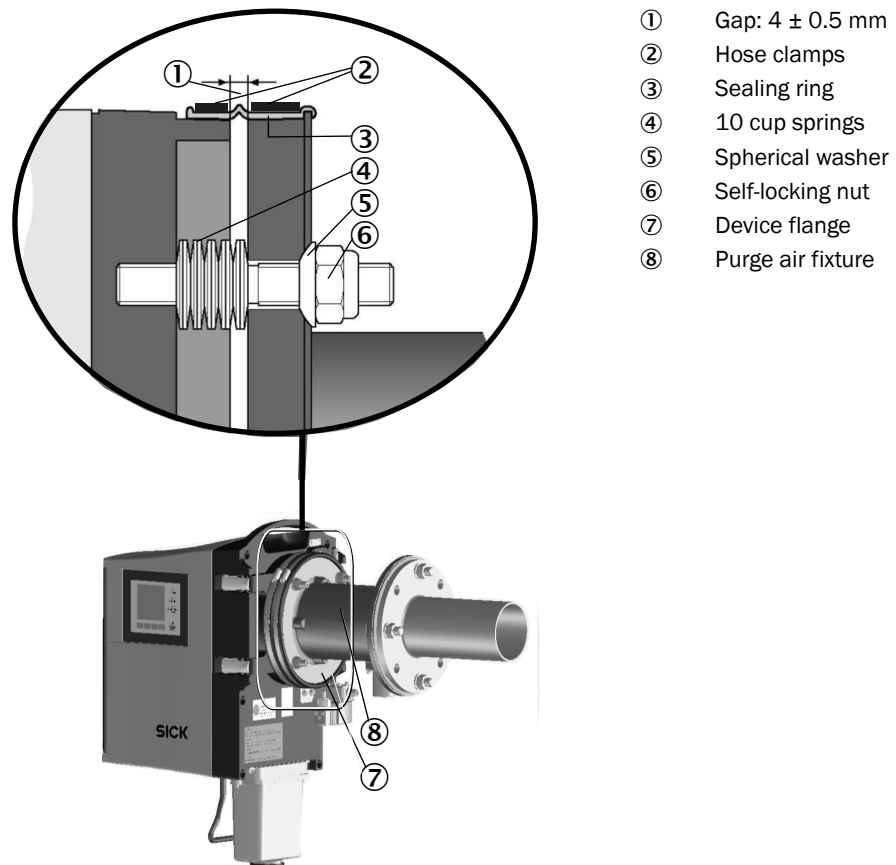

Figure 24: Installing the device flange on the purge air fixture

- 1 Put 10 cup springs each, back-to-back, onto the three threaded bolts on the device flange.
- 2 Pull the sealing ring over the flange of the purge air fixture and hang it loosely over the purge air unit.
- 3 Push the device flange onto the purge air fixture.
- 4 Position the centering discs.



**NOTICE**

Observe the direction of the centering disc: The convex side must fit into the groove on the purge air fixture.

- 5 Tighten the self-locking nuts with a wrench (19 mm) so that the cup springs are slightly compressed and an even gap of approx. 4 mm remains.
- 6 Fit the sealing ring over the gap.
- 7 Push the two hose clamps over the sealing ring and screw tight.



## 7.7 Aligning device flanges and purge air fixtures

### Adjustment device

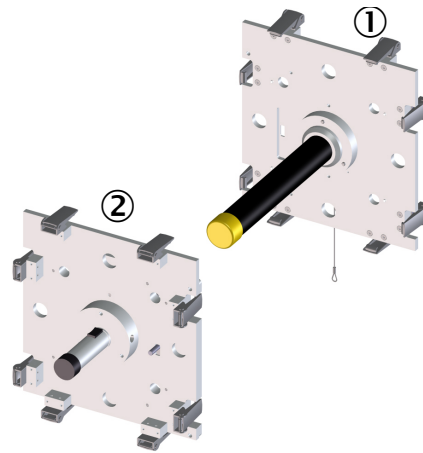

Figure 25: Adjustment device

- ① Adjustment device, aiming unit (focusing screen with visor)
- ② Adjustment device, light source



### CAUTION

Risk of explosion when using a light source not suitable for Ex for adjustment in Ex zone 2

If the adjustment device is set up within Ex zone 2, the LED light with identification DEMKO 13 ATEX1302999 X EX II 1 G Ex ia UC T4 must be used.

- Order the LED lamp set from SICK, Part No.: 2042835

### Install the adjustment device with light source at the side of the receiver unit

- 1 Place the adjustment device with light source on the device flange of the SR-unit.
- 2 Fasten with quick-release fasteners.

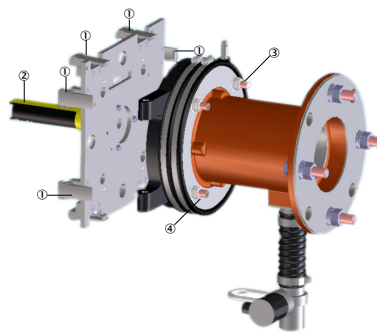

- ① Quick-release fastener
- ② Adjustment tube
- ③ Screw for horizontal adjustment of light spot
- ④ Screw for vertical adjustment of light spot

### Installing the adjustment device with adjustment tube on the side of the reflector unit

- 1 Remove the protective cap from the adjustment tube.
- 2 Insert the adjustment device with tube into the device flange.

- 3 Fasten with quick-release fasteners.

**NOTE**

Both pins of the device flange must fit into the respective drilled holes of the adjustment device.

---

**Adjusting**

The alignment is performed on the device flange which contains the adjustment tube:

- 1 Align with the screws for the horizontal and vertical adjustment until the light spot is at the center of the target on the adjustment tube.
- 2 Interchange the adjustment device with light source and the adjustment tube.
- 3 Align the flange with adjustment tube again until the light spot is shown centrally in the target of the adjustment tube.

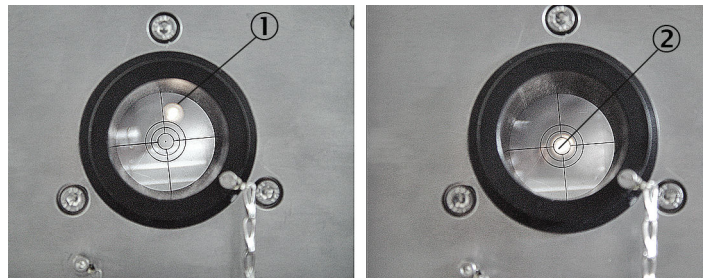

① Not aligned correctly

② Aligned correctly

- 4 Remove the adjustment device again.
  - 5 Attach the protective cap and pack free from dust and humidity for storage.
- 

**NOTE**

If centering is not possible: Unscrew the device flanges from the “flange with tube” and check the optical alignment of the “flange with tube”.

---

### 7.8 Connecting the protective gas on the SR-unit

The protective gas connection is on the intermediate enclosure.

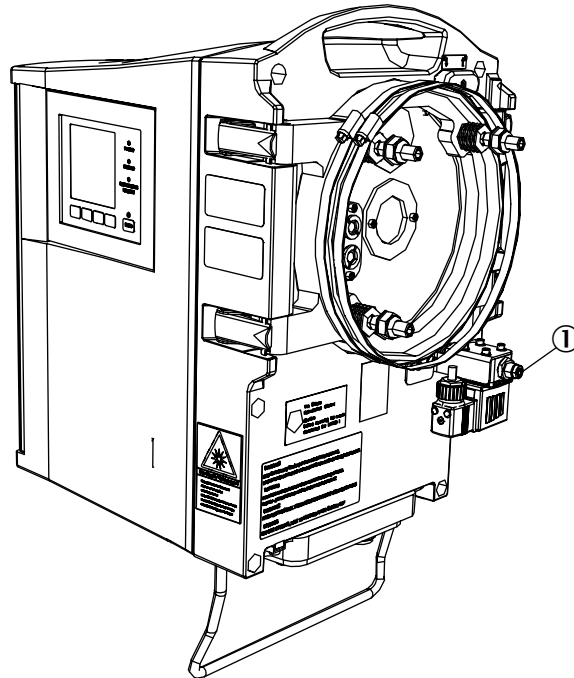

Figure 26: Connection for protective gas on GM32 Ex

- ①
- G3/8" thread or
  - Hose connection for 8 mm diameter

### 7.8.1 Feeding protective gas



#### NOTICE

The pressurized enclosure requires a permanent supply of a protective gas.

- ▶ Feed the protective gas via the protective gas connection. More information concerning protective gas:
  - Requirements for protective gas, [page 96](#).
  - Protective gas outlet: [see "Fitting the FS850S", page 29](#).

### 7.8.2 Switching the pressurized enclosure on

#### Ex category 3G

- 1 Switch the main power supply of the pressurized enclosure system on (at an external source).
- 2 The pressurized enclosure system will start pre-purging the enclosure with protective gas. The Ex control unit will signal the end of the pre-purge phase.
- 3 Switch the main power supply of the GM32 Ex on (at an external source).

## 7.9 Installing the SR-unit and reflector unit on the device flange

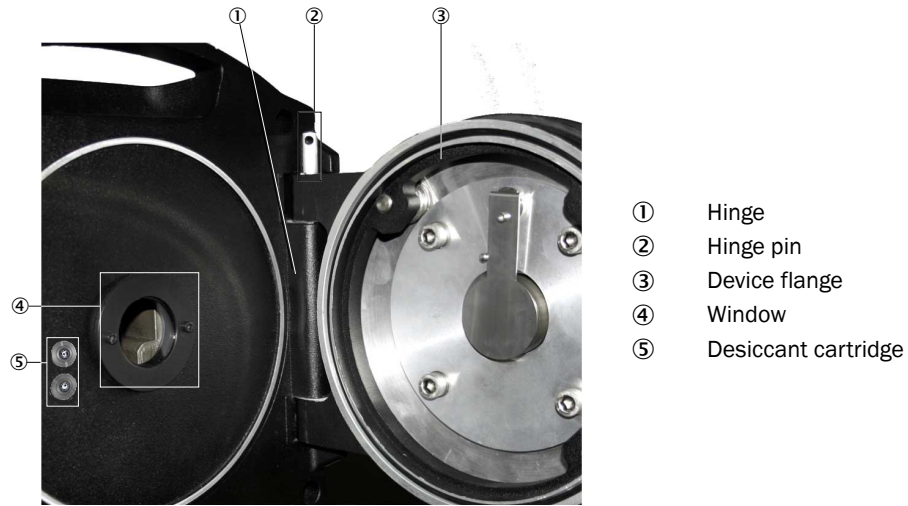

Figure 27: Hinge of the sender/receiver unit

### Fit the sender/receiver unit on the device flange

- 1 Fit the SR-unit on the device flange into the hinge.



#### NOTE

**Recommendation: Install the flange on the left.**

The device flange can be installed on the left or right. The advantage of installation on the left is the unhindered access to the device display when working on the swiveled out flange.

- 2 Insert the hinge pin from above in the hinge.



#### NOTICE

**The SR-unit can drop down when swiveled when the hinge bolt is not inserted properly**

- ▶ Ensure the hinge pin is fully inserted.

- 3 Check the window for cleanness and clean, if required, see ["Cleaning the window"](#), page 70.
- 4 Check the desiccant cartridge for dryness, see ["Check/replace the desiccant cartridge"](#), page 70.
- 5 Close the SR-unit with the 4 quick-release fasteners.

### Install the reflector unit on the intermediate flange

- 1 Insert the reflector unit in the hinge of the device flange.
- 2 Insert the hinge pin from above in the hinge.
- 3 Close the reflector unit with the 4 quick-release fasteners.

## 7.10 Optical fine alignment of the SR-unit

- With SOPAS ET: Description in SOPAS ET Manual. Leave this work to a skilled person familiar with SOPAS ET.
- With operating unit, see ["Alignment check \(option\) - automatic optical alignment check"](#), page 60.

## 7.11 Fitting the weatherproof cover (option)

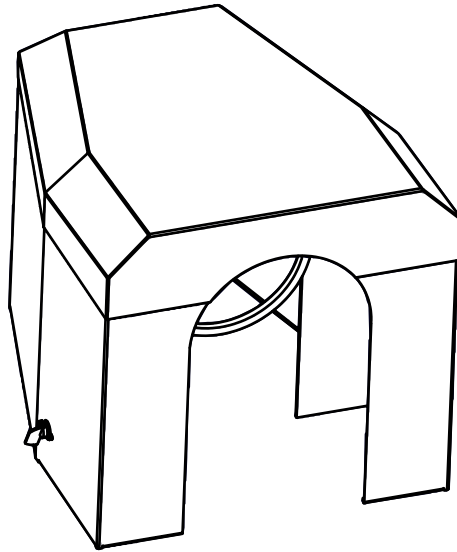

Figure 28: Weatherproof cover, complete

### Installing the weatherproof cover of the sender/receiver unit:

- 1 Install the installation plate on the flange of the purge air fixture.
  - ▷ Lay the weatherproof cover upside down on the floor.
  - ▷ Open and unhinge the locking bolts on both sides.
  - ▷ Pull the installation plate upwards and remove it from the cover.
  - ▷ Remove the bottom mounting ring.
  - ▷ Place the installation plate onto the rubber band of the purge air fixture from the top.
  - ▷ Position the mounting ring on the side of purge air fixture.
  - ▷ Screw the bottom mounting ring to the top mounting ring.

1

2

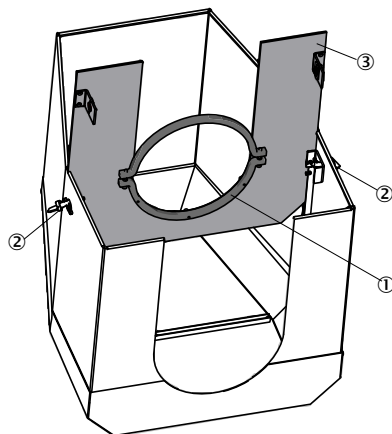

- ① Mounting ring
- ② Locking bolts
- ③ Installation plate

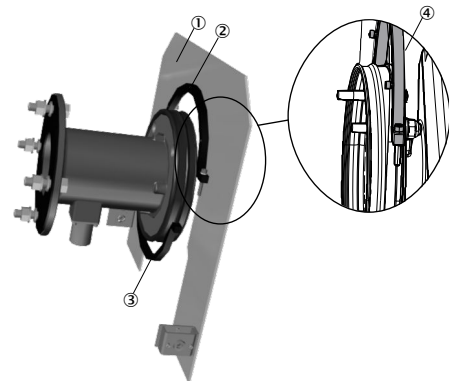

- ① Installation plate
- ② Top mounting ring
- ③ Bottom mounting ring

- 2 Place the weatherproof cover on the installation plate.
  - ▷ Position the cover on the installation plate from the top.
  - ▷ Engage the locking bolts and close again.

3



4

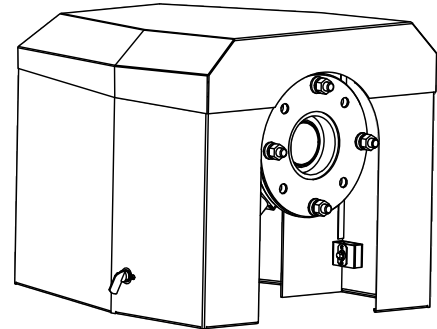

## 8 Operation

### 8.1 Safety

**WARNING**

**Hazard for persons and plant through unsafe operation of the measuring system**

If the device is or could be in an unsafe state:

- ▶ Put the device out of operation.
  - ▶ Disconnect the device from the main supply voltage and signal voltage.
  - ▶ Secure the device against unallowed or unintentional start-up.
- 

**NOTE**

More information concerning the detection of unsafe operating states, see Chapter "Visual check".

---

### 8.2 GM32 operator panel

**NOTE**

On the GM32 "Pro" device version, the operator panel is on the right side of the SR-unit housing.

---

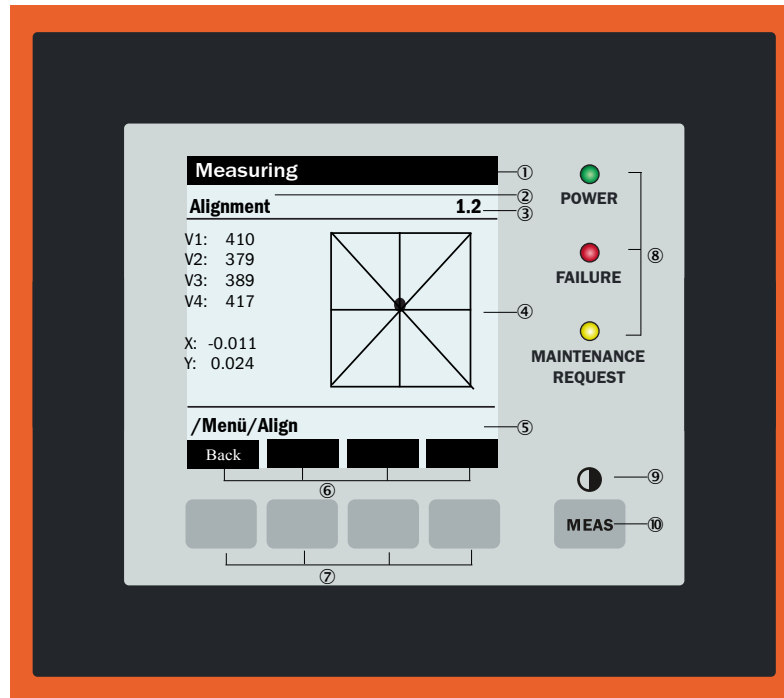





Figure 29: Operating and display elements (with example menu)

- ① Status bar
- ② Current menu
- ③ Current menu index
- ④ Display of values
- ⑤ Current menu branch
- ⑥ Significance of function buttons (menu-dependent)
- ⑦ Function buttons
- ⑧ Status LED
- ⑨ Contrast symbol
- ⑩ "MEAS" button

► To activate a function button: Simply touch the button surface with a finger.

### 8.2.1 LEDs

LED	Significance / possible cause
 POWER	The device is switched on, power voltage is available.
 FAILURE	<ul style="list-style-type: none"> <li>• At least one error code is active.</li> <li>• The "Maintenance operation" state is activated manually.</li> </ul>
 MAINTENANCE REQUEST	At least one error code is active.



## 8.2.2 Function buttons

Button	Function
MEAS	Back to the Measuring screen from any menu. All inputs that have not been terminated with Save are discarded.
	 To set the contrast: Press the MEAS button for more than 3 seconds, see <a href="#">"Setting the display contrast"</a> , page 58.

The current function of the function buttons is shown on the display.

Display	Function
Back	Return to the higher level menu. Press <Save> to store any changes made. Otherwise the changes are lost.
Diag	Diag only appears when a message is pending. To display the message: Press this button.
Enter	Call up/start selected menu function.
Menu	Call up the main menu. If the <Menu> button is not shown: Press MEAS first.
Save	Save input/exit.
Set	Start setting.
Select	Select function/character.
Start	Start procedure.
↑	In a selection list: Move cursor upwards.
	During input: Next character.
↓	Move cursor downwards.
←	Move cursor to the left.
→	Move cursor to the right.

8.2.3 Setting the display contrast

1. Press the **MEAS** button for several seconds.
- ✓ The measuring screen appears first.
- ✓ Then the menu to set the contrast appears.

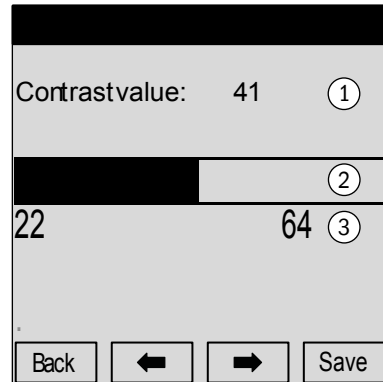

- 1 Current setting
- 2 Graphic for current setting
- 3 Setting range

Figure 30: Menu to set the contrast (with setting example)

2. Select **←/→** until the desired setting is reached.
3. Save the new setting with function button "Save".

8.2.4 Menu tree

- The menu tree shown here refers to operation via the operator panel on the “Pro” device variant.
- Device settings can not be changed with the operator panel.
- No user levels.



**NOTE**

Changes on the device are possible only via SOPAS ET.



**NOTE**

Menu texts are shown in **English**.

**Menu level**

**Explanation**

**1.1 Diagnosis**

**Diagnosis**

- 1.1.1 Failure
- 1.1.2 Maintenance (request)
- 1.1.3 Uncertain
- 1.1.4 Check cycle

Malfunction, see Chapter Diagnosis.  
Maintenance request, see Chapter Diagnosis.

**1.2 Alignment check**

See Chapter Diagnosis.  
[see "Check cycle - results of last check cycle", page 59.](#)  
[see "Alignment check \(option\) - automatic optical alignment check", page 60.](#)

**1.3 Adjustments**

- 1.3.1 Alignment adjust
- 1.3.2 Check cycle
- 1.3.3 Reference cycle

[see "Alignment check \(option\) - automatic optical alignment check", page 60.](#)  
[see "Check cycle", page 17.](#)  
[see "Reference cycle", page 17.](#)

**1.4 IP Configuration**

View the IP settings

- 1.4.1 IP
- 1.4.2 M

IP address  
Subnet mask

## 1.4.3 GW

## Gateway

## 1.5 Maintenance

Maintenance, see "Maintenance mode - set Maintenance mode ", page 62.

## 8.2.4.1 Diagnosis





The "Diagnosis" menu shows the current error messages.

the following information is available for troubleshooting:

- The GM32 signals a malfunction or an unsafe operational state with status signals (option). See electrical connection diagram.
- Logbook: Access to the logbook via SOPAS ET, see "SOPAS ET (PC program)", page 16.
- List of error messages and measures for clearing malfunctions, see "Error messages", page 80.

## Status messages, status indicators and system states

Table 7: 1

Status	LED	Significance	Measured value display	Analog outputs <sup>1</sup>	Status signal <sup>2,3</sup>
Power on (main supply voltage on)		Power supply in order	--		
Uncertain (Uncertain)	 Measured value blinks	<ul style="list-style-type: none"> <li>• Measured value uncertain (e.g. outside calibration range)</li> <li>• Cause: Press the DIAG button</li> <li>• All messages in the SOPAS ET logbook</li> <li>• Troubleshooting, <a href="#">Error messages</a></li> </ul>	Current		According to setting
Maintenance request (maintenance request message)		<ul style="list-style-type: none"> <li>• Irregularities (e.g. gas temperature too high, deviation from check cycle too high) that require a review of the cause</li> <li>• The measured values are valid</li> <li>• Press the DIAG button: Error display</li> <li>• All messages in the SOPAS ET logbook</li> <li>• Troubleshooting, see "Error messages", page 80</li> </ul>	Current		
Failure (malfunction)		<ul style="list-style-type: none"> <li>• Device failure (e.g. lamp failed)</li> <li>• Cause: Press the DIAG button</li> <li>• All messages in the SOPAS ET logbook</li> <li>• Troubleshooting, see "Error messages", page 80</li> </ul>	Last valid measured value held		

<sup>1</sup> Option

<sup>2</sup> Option. Refer to the delivered System Documentation for the assignment of the status outputs.

<sup>3</sup> See SOPAS ET in the "Digital outputs" menu.

## 8.2.4.2 Check cycle - results of last check cycle

**NOTE**

The results of the last check cycle can be called up in this menu item.

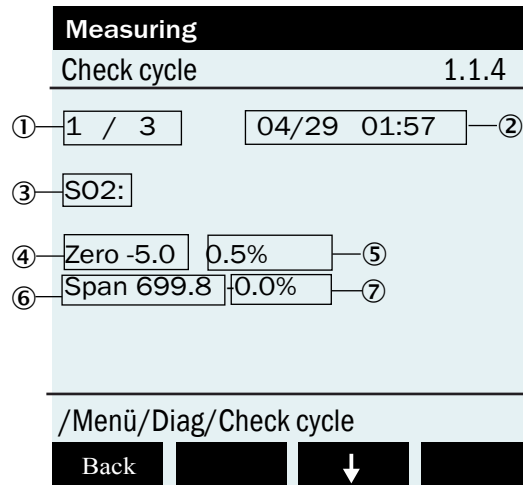

Figure 31: Description of the check cycle display

- ① Channel (in the example: Channel 1 of 3, corresponding to configuration)
- ② Date (MM/DD) and time of the last check cycle
- ③ Gas component
- ④ Zero adjust result, absolute value (in configured unit)
- ⑤ Deviation in percentage of FS
- ⑥ Span adjust result (70 %), absolute value (in configured unit)
- ⑦ Deviation from FS in percent

1 FS = full scale value: Scale limit value of the assigned analog output

8.2.4.3 Alignment check (option) - automatic optical alignment check

This menu serves to view the values of automatic optical alignment.



**NOTICE**

- ▶ Perform this check only when the SR-unit is at operating temperature (in operation for at least 30 minutes).
- ▶ Automatic mirror adjustment - do not perform manual adjustments.



**NOTE**

Further information on optical alignment, see Chapter Adjustment.

**Toggle between "Deviation" and "Performed steps of tracking mirror"**

- ▶ Press the **Down arrow button**.
- ▶ Exit the menu item with the **Back button**.

8.2.4.4 Alignment adjust - manual optical alignment



**NOTICE**

- ▶ Only carry out this check when the SR unit is at operating temperature (minimum 30 minutes in operation).

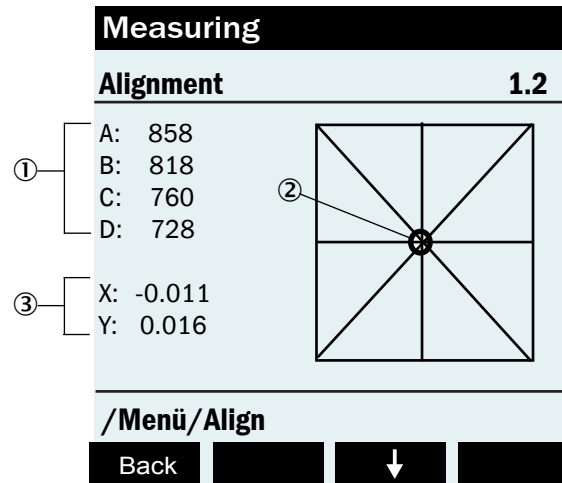

Figure 32: Shows the optical alignment on the device display

- ① Light energy
- ② Focal point
- ③ X/Y values

### Performing the optical alignment

- 1 Press the **Start** button. A crosshair with a focal point and X/Y values are shown on the screen.



#### NOTE

The focal point is in the center of the crosshair when the following tolerances are shown:

- X: -0.05 ... +0.05
- Y: -0.05 ... +0.05

- 2 Carry out optical alignment: Carry out optical alignment by adjusting the two setting screws on the device flange of the SR-unit (19 mm wrench).



#### NOTICE

The display on the monitor reacts to the adjustment with a delay.

- ▶ Perform adjustments slowly and wait for approx. 20 seconds until the display on the monitor has been updated.

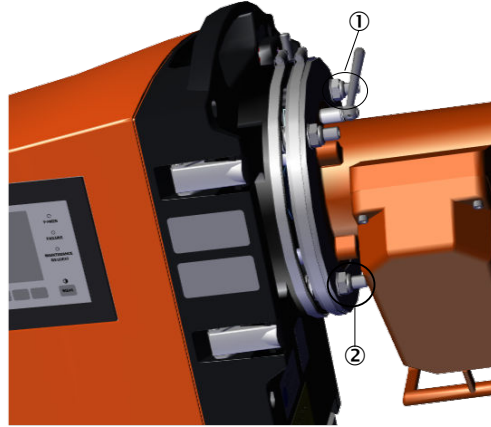

Figure 33: Alignment of device flange

- ① Optical alignment, horizontal
- ② Optical alignment, vertical

- Horizontal adjustment: Horizontal adjustment of the focus.
- Vertical adjustment: Vertical adjustment of the focus.

3 Check the values for the light energy:

- The values for the light energy V1 ... V4 must be in the range 250 ... 500.
- The values must approximately have the same size.

**If the focal point cannot be seen or adjustment is not possible, check:**

- ▷ Correct distance between device flange and purge air fixture, see ["Installing the device flange on the purge air fixture"](#), page 47.
- ▷ Optical alignment, see ["Aligning device flanges and purge air fixtures"](#), page 49.
- ▷ Contaminated window, see ["Cleaning the window"](#), page 70.
- ▷ Defective sender lamp, see ["Replacing the sender lamp"](#), page 72.



**NOTE**

Recommendation: Start check cycle after each manual start and maintenance measure.

8.2.4.5 Maintenance mode - set Maintenance mode

Operating mode "Maintenance" is signaled via this menu. Measurement is stopped, the value measured last is held.

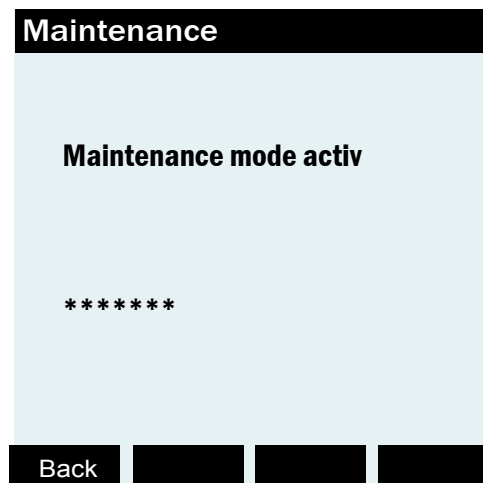

- Stay in Maintenance mode, display of held measured value: Press the **Back** button.
- Exit Maintenance mode, current measured value display: Press the **Meas** button.

## 9 Maintenance

### 9.1 Safety

#### Ex safety

---



#### WARNING

##### Risk of explosion

Some of the work described in this Chapter assumes an Ex free zone.

- ▶ Wait 20 minutes after switching off the main power supply before opening the enclosure.
- 



#### DANGER

##### Risk of explosion through incorrect performance of maintenance work

Incorrect performance of maintenance work in potentially explosive atmospheres can cause serious injuries to people and damage during operation.

- Maintenance and commissioning tasks as well as checks should only be carried out by experienced/trained personnel with knowledge of the rules and regulations for potentially explosive atmospheres, especially:
    - Ignition protection types
    - Installation procedures
    - Zone classification
  - Standards to be applied:
    - IEC 60079-14, Annex F: Knowledge, skills and competencies of responsible persons, operatives and designers
    - IEC 60079-17: Electrical installations inspection and maintenance
    - IEC 60079-19: Equipment repair, overhaul and reclamation
- 



#### DANGER

##### Risk of explosion when using spare and wearing parts not approved for the Ex zone

All spare and expendable parts for the In-situ gas measuring device have been checked by SICK for ATEX suitability. The use of different spare parts and expendable parts increases the risk of an explosion and the ignition protection can no longer be ensured.

- ▶ Use only original spare parts and expendable parts from SICK.
- 



#### DANGER

##### Risk of explosion through residual voltages and hot surfaces in the device

When the device is switched off, residual voltages and hot surfaces represent an increased risk of explosion when the device is open.

- ▶ Wait 20 minutes after switching off the main power supply before opening the enclosure.
-



**DANGER****Hazard for health through contact with inert protective gas**

Protective gas can emerge uncontrolled when the device is opened directly after switching off. Direct contact with the inert protective gas is a high health risk, including risk of suffocation.

- ▶ Interrupt the inert gas feed before opening the device so that only the volume of inert gas in the device can escape.
- ▶ Ensure good ventilation and air exchange.
- ▶ Never open the device when the room is too small.

**CAUTION****Risk of device damage when the optics purge air is switched off too soon**

Hot and contaminated gas can cause device damage when the purge air is switched off when the SR-unit or the reflector is still in the gas duct.

- ▶ Do not disconnect the purge air unit as long as the SR-unit or the reflector is still in the gas duct.

**WARNING****Endangerment of electrical safety during installation and maintenance work when the power supply is not switched off**

An electrical accident can occur during installation and maintenance work when the power supply to the device and/or lines is not switched off using a power isolating switch/circuit breaker.

- ▶ Before starting the work, ensure the power supply can be switched off using a power isolating switch/circuit breaker in accordance with DIN EN 61010.
- ▶ Make sure the power isolating switch is easily accessible.
- ▶ An additional separation device is mandatory when the power isolating switch cannot be accessed or only with difficulty after installation of the device connection.
- ▶ The power supply may only be switched on again after work completion or for test purposes by persons carrying out the work under consideration of the valid safety regulations.

**DANGER****Endangerment of electrical safety through missing power isolating switch**

An electrical accident can occur during installation and maintenance work when the power supply to the device and/or lines cannot be switched off using a power isolating switch/circuit breaker.

- ▶ Ensure the power supply can be switched off using a power isolating switch/circuit breaker in accordance with DIN EN 61010-1:2010.
- ▶ An additional separation device is mandatory when the power isolating switch cannot be accessed or only with difficulty after installation of the device connection.



**WARNING**

**Risk of chemical burns/poisoning through caustic/toxic residues on components with sample gas contact**

After the device has been decommissioned or removed from the measuring duct, process gas residues can exist as deposits on components with sample gas contact (e.g., gas filter, gas-carrying lines etc.). These residues can be odorless or invisible depending on the gas mixture in the duct. Without protective clothing, contact with such contaminated components can lead to severe burns or poisoning.

- ▶ Take appropriate protective measures for work (e.g., by wearing a safety mask, protective gloves and acid resistant clothes).
- ▶ In case of contact with skin or the eyes, rinse immediately with clear water and consult a doctor.
- ▶ Decontaminate all contaminated components according to regulations after disassembly.



**WARNING**

**Risk of injury through uncontrolled escape of process gas when the gas duct is opened when under overpressure**

Swiveling the SR-unit or reflector unit (on Cross-Duct version) open can lead to contact with toxic and/or hot gases with overpressure in the duct.

- ▶ All persons at the gas duct during opening of the device must follow the protective measures mandatory in operation. Pay special attention to protective masks and protective gloves.
- ▶ Prepare a suitable cover of the opening in the device flange of the SR-unit and reflector (for Cross-Duct version) and have it available.
- ▶ Attach the cover to the device flange opening immediately after swiveling the SR-unit open (reflector unit, for Cross-Duct version).

## 9.2 Maintenance plan

Table 8: Maintenance intervals

Interval <sup>1</sup>	Maintenance task	Reference
1W	Check measured and control values (zero / test point)	
3M	Visual inspection of system	see "Visual inspection", page 69
	Clean the window	see "Cleaning the window", page 70
	Check desiccant cartridges, replace when necessary. Replace at the latest after 6 months	see "Check/replace the desiccant cartridge", page 70
	Check the purge air unit	See SLV Operating Instructions
	Check the optical alignment	see "Alignment check (option) - automatic optical alignment check", page 60
6M	Check the pressurized enclosure system	see "Function test of the pressurized enclosure system", page 67
	Protective gas: Condition, availability, pressures	see "Checking the protective gas feed"
1Y	Replace the activated charcoal sachet	see "Replacing the activated charcoal bag", page 71

<sup>1</sup> 1W = Weekly, 1M = Monthly, 3M = Every 3 months, 6M = Every 6 months, Y = Yearly

### 9.2.1 Consumable parts, expendable parts and spare parts Recommendation for 2 years operation

Part	Number	Part No. (per piece)
Sender lamp, EX version	2 pcs	2064932
Desiccant cartridge	8 pcs	2010549
Activated charcoal sachet	2 pcs	5323946
Optical cleaning cloth	8 pcs	4003353
Filter insert for purge air unit	8 pcs	5328662

### 9.3 Preparation work



**NOTICE**

**Some maintenance tasks will cause the device to switch to malfunction**

- ▶ Activate Maintenance mode before starting to work.

### 9.4 Function test of the pressurized enclosure system

All maintenance work of the pressurized enclosure system is described in the Pressurized Enclosure Manual.



**WARNING**

**Risk of injury through electric voltage**

Switch the power supply off before working on terminals and laying lines.

- ▶ Observe the installation regulations according to VDE DIN 57 165 and Test Certificate BVS 06 ATEX E088.



**WARNING**

**Risk of explosion through unauthorized parameter changes**

The parameters for the pressurized enclosure system are protected with a parameter password and cannot be changed. Unauthorized changing of parameters can cause an explosion with fatal consequences.

- ▶ Never change parameters without authorization.



**DANGER**

**Risk of explosion when the maintenance of the pressurized enclosure is incorrect**

The pressurized enclosure is a central part of the ATEX certification of the device. All maintenance work is described in the Pressurized Enclosure Manual. If work is performed which is not described in this Manual, the risk of explosion of the measuring system increases and the ATEX certification becomes void.

- ▶ Also observe the maintenance instructions in the Pressurized Enclosure Manual.



**DANGER**

**Risk of explosion through incorrect settings for the pressurized enclosure**

The pressurized enclosure is a central safety part of the device. All work is described in this Manual and the relevant specified documents. If work is performed which is not described in this Manual, the risk of explosion of the measuring system increases and the ATEX certification for the device becomes void.

- ▶ Carry out all work skillfully and in accordance with the delivered documentation.

## 9.5 Swiveling out and removing the SR-unit or reflector unit



### DANGER

#### Damage to eyes and skin by UV radiation

The in-situ gas measuring device GM32 emits UV radiation when the SR-unit or reflector unit is opened during operation. Exposure of the unprotected skin and eyes to radiation is dangerous to health.

- ▶ Disconnect the power supply of the device before opening the device.
- ▶ Wear suitable protective goggles and protective gloves when work on the open device with the power supply connected is performed.



### DANGER

#### Danger resulting from escaping gas when the SR-unit and reflector unit are swiveled out

Overpressure in the gas duct can cause hot and/or noxious gases to escape when the SR-unit is swiveled out.

- ▶ Swivel the SR-unit or reflector unit out only when you have taken suitable safety measures.



### CAUTION

#### Prevent dropping of the SR-unit and reflector unit

If the hinge pin has not been correctly inserted, the SR-unit can drop when swiveled out.

- ▶ Before swiveling the SR-unit out, check the hinge pin is completely pressed down. The SR-unit and the reflector unit are heavy.
- ▶ Hold the respective units tight when pulling out the pin.

### 1. Swivel out the SR-unit or reflector unit

- 1 Open the four quick-release fasteners of the SR-unit or reflector unit.
- 2 Swivel the SR-unit out.



① Quick-release fasteners



② Hinge pin

**2. Take off the SR-unit or reflector unit**

- ▶ Hold the unit.
- ▶ Pull out the hinge pin.
- ▶ Take off the SR-unit or reflector unit.

**9.6 Visual inspection**

- ▶ Check the housings of the SR-unit and connection unit for mechanical damage.
- ▶ Clean the housings if contaminated.
- ▶ Check all cables for damage. Pay attention to chafe marks and kinks on cable ducts.
- ▶ Check flanges and screw fittings for firm seating.

### 9.7 Cleaning the window



**NOTE**

Window cleaning of the SR-unit and the reflector unit is identical.

Required material	Part No.
Optical cleaning cloth	4003353
Demineralized water	

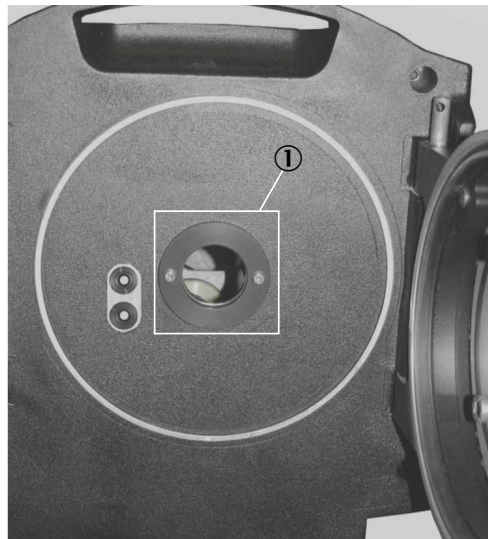

Figure 34: Window

① Window

- 1 Swivel out the SR-unit or reflector unit, see "Swiveling out and removing the SR-unit or reflector unit", page 68.
- 2 Clean the window with an optical cleaning cloth and demineralized water.



**NOTICE**

Do not use cleaning agents.

- 3 Close the SR-unit or reflector unit again.

### 9.8 Check/replace the desiccant cartridge

Material required	Part No.
Key (delivered with desiccant cartridge)	4020395
Desiccant cartridge (1)	2010549

The desiccant cartridges are in the sender/receiver unit next to the window.

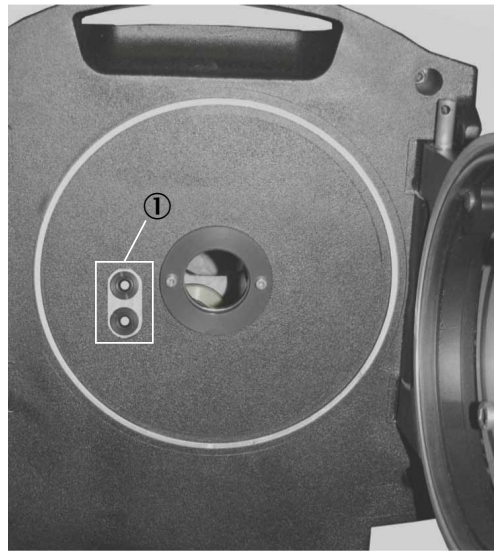

Figure 35: Desiccant cartridges

① Two desiccant cartridges

- 1 Swivel the SR-unit out, see "Swiveling out and removing the SR-unit or reflector unit", page 68.
- 2 Check the condition of the desiccant cartridge:
  - Light blue: Desiccant cartridge is dry.
  - White: Replace the desiccant cartridge.
- 3 Replacing the desiccant cartridge:
  - ▷ Unscrew the desiccant cartridge.
  - ▷ Screw in the new desiccant cartridge.
- 4 Close the SR-unit again.



**WARNING**

Leakage can revoke zone separation

Zone separation is endangered when the desiccant cartridge is not screwed in tight after replacement.

- ▶ Ensure the desiccant cartridge is screwed in tight.

- 5 Set the lever on the purge air fixture to "Open" again.

## 9.9 Replacing the activated charcoal bag

Material required	Part No.
5 mm Allen key	
Activated charcoal sachet	5323946



**CAUTION**

The sender/receiver housing may be opened only in a dry, clean environment.

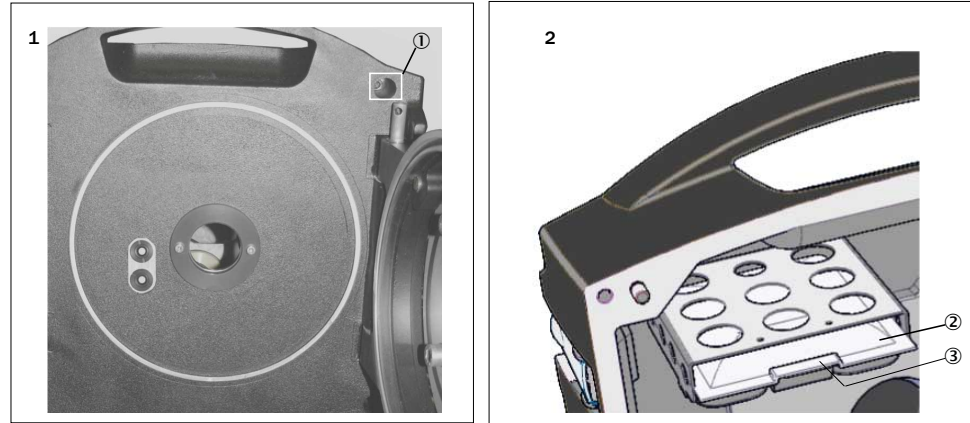

Figure 36: Loosen the screws and replace the activated charcoal filter sachet

- ① Screw (1 of 6)
- ② Activated charcoal bag
- ③ Spring

- 1 Take the SR-unit off, see "Swiveling out and removing the SR-unit or reflector unit", page 68.
- 2 Place the SR-unit in a clean, dry place with little dust.
- 3 Loosen six screws. (see Figure)
- 4 Take the cover off to the rear.
- 5 Replace the used activated charcoal sachet with a new one.
- 6 Replace the cover and screw tight.
- 7 Refit the SR-unit.

### 9.10 Replacing the sender lamp

Material required	Part No.
Phillips screwdriver	
Allen key (5 mm)	
Sender lamp	2064932
Heat-resistant support	



**WARNING**  
Burns by touching the hot sender lamp

When the sender lamp is replaced, it can still be very hot.

- ▶ Wear suitable protective gloves.
- ▶ Place the sender lamp only on a heat-resistant underlay.



**CAUTION**  
Device damage through short circuit on the device

The internal electronics can be damaged when signal connections are established and the power supply is switched on. This is also valid for plug connections.

- ▶ Disconnect the GM32 Ex and any connected devices from the voltage supply.



**Preparation work**

- 1 Disconnect the device from the power supply.
- 2 Loosen 5 screws on the rear side of the SR-unit and swivel the rear cover out.
- 3 Pull off the lamp cover.

**Step 1: Open the cover**

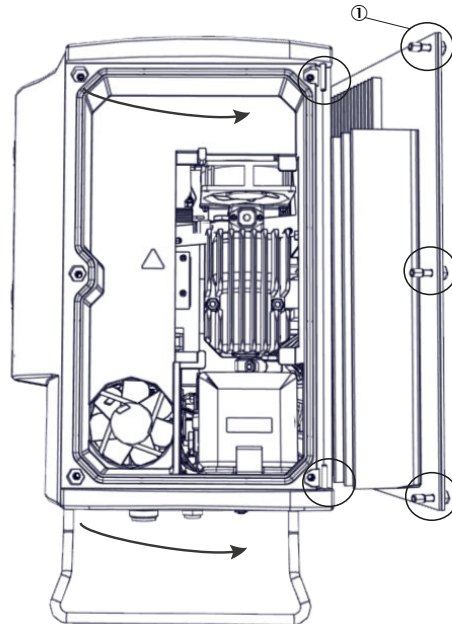

Figure 37: Taking the cover off

- ① Self-locking M5 screws (x5)

**Step 2: Remove the cover**

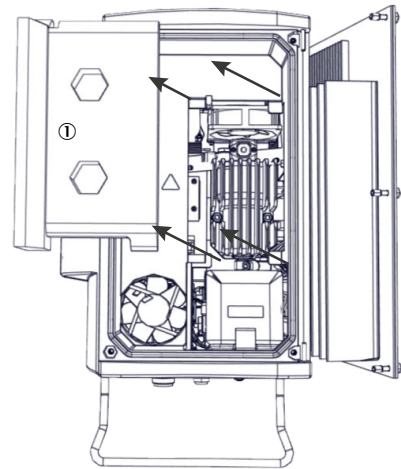

Figure 38: Pulling the lamp cover off

- ① Lamp cover

**Replacing the sender lamp**

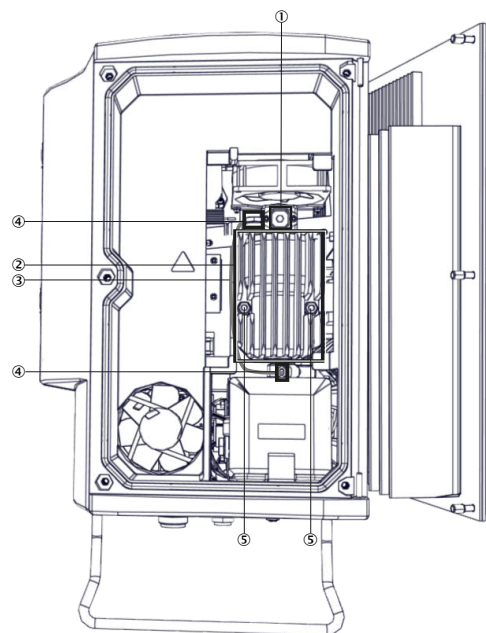

Figure 39: Replacing the sender lamp

- ① Plug screw
- ② Sender lamp
- ③ Tube
- ④ Tube screw fitting
- ⑤ Screws of the sender lamp

- 4 Loosen the plug screw (crosshead). Disconnect the plug.
- 5 Loosen 2 screws of the sender lamp with an Allen key.
- 6 Remove the sender lamp. Pull the lamp out slightly to the rear.
- 7 Push the blue ring on both hose fittings and pull the hose off.
- 8 Remove the cap from the new sender lamp.
- 9 Plug in the two tube ends to the hose fittings.
- 10 Plug in new sender lamp and screw tight.
- 11 Connect the plug and screw tight.
- 12 Plug in the lamp cover.
- 13 Screw the rear cover tight.

**NOTE**

Adjustment is not required.

---

## 10 Troubleshooting

### 10.1 Safety

#### Prerequisites

---



#### **DANGER**

##### **Risk of explosion through residual voltages and hot surfaces in the device**

When the device is switched off, residual voltages and hot surfaces represent an increased risk of explosion when the device is open.

- ▶ Wait 20 minutes after switching off the main power supply before opening the enclosure.
- 



#### **WARNING**

##### **Risk of explosion**

Some of the work described in this Chapter assumes an Ex free zone.

- ▶ Wait 20 minutes after switching off the main power supply before opening the enclosure.
- 



#### **DANGER**

##### **Risk of explosion through incorrect performance of maintenance work**

Incorrect performance of maintenance work in potentially explosive atmospheres can cause serious injuries to people and damage during operation.

- Maintenance and commissioning tasks as well as checks should only be carried out by experienced/trained personnel with knowledge of the rules and regulations for potentially explosive atmospheres, especially:
    - Ignition protection types
    - Installation procedures
    - Zone classification
  - Standards to be applied:
    - IEC 60079-14, Annex F: Knowledge, skills and competencies of responsible persons, operatives and designers
    - IEC 60079-17: Electrical installations inspection and maintenance
    - IEC 60079-19: Equipment repair, overhaul and reclamation
- 



#### **CAUTION**

##### **Device damage through short circuit on the device**

The internal electronics can be damaged when signal connections are established and the power supply is switched on. This is also valid for plug connections.

- ▶ Disconnect the GM32 Ex and any connected devices from the voltage supply.
-



### WARNING

#### **Risk of chemical burns/poisoning through caustic/toxic residues on components with sample gas contact**

After the device has been decommissioned or removed from the measuring duct, process gas residues can exist as deposits on components with sample gas contact (e.g., gas filter, gas-carrying lines etc.). These residues can be odorless or invisible depending on the gas mixture in the duct. Without protective clothing, contact with such contaminated components can lead to severe burns or poisoning.

- ▶ Take appropriate protective measures for work (e.g., by wearing a safety mask, protective gloves and acid resistant clothes).
  - ▶ In case of contact with skin or the eyes, rinse immediately with clear water and consult a doctor.
  - ▶ Decontaminate all contaminated components according to regulations after disassembly.
- 

### Electrical safety

---



### DANGER

#### **Electrical accident through bare, live lines**

When uninstalling, unsecured, live lines can lead to serious accidents.

- ▶ Switch the power supply to the device off before starting uninstallation.
  - ▶ If power supply is required during uninstallation: Secure all live lines during uninstallation work so that nobody can be injured.
- 



### DANGER

#### **Hazard by voltage**

Lines in the subassemblies of the measuring system are live and can cause serious injuries through electric shock when touched.

- ▶ Disconnect the subassemblies or lines involved from the power supply during installation, maintenance and repair work.
- 

## 10.2 Visual inspection

---



### WARNING

#### **Danger for persons and system caused by unsafe operation of the measuring system**

If the device is or could be in an unsafe state:

- ▶ Put the device out of operation.
  - ▶ Disconnect the device from the main power supply and signal voltage.
  - ▶ Prevent unauthorized or unintentional start-up.
-

Table 9: Visual inspection

Malfunction		Action
Smoke	escapes from the enclosure	1 Have the device repaired.
Gas		1 Immediately check whether the gas is noxious or combustible. 2 If this is the case: Immediately follow the local Operating Instructions which control behavior during uncontrolled escape of gas. Examples of behavior when gas escapes uncontrolled: ▷ Stop the affected gas supply. ▷ Trigger an alarm. Start emergency measures. ▷ Immediately evacuate all persons from the affected operational area. ▷ Use breathing protection.
Moisture	penetrates the enclosure	1 Locate and stop the liquid source. 2 Have the device repaired.
	on electric connections	1 Dry connections and interior of the enclosure.
Damage	Electric lines	1 Have the damage repaired by a skilled electrician.
	Surface	1 Have the device repaired. 2 If caused by acute external influence: Locate the cause and take measures to protect the device. 3 Have the installation location checked by a technician when necessary.
Unusual noises	Inside the device	1 Check malfunction indications and messages. 2 Have the device checked by a skilled person.
Malfunctions after fault clearing		► Contact SICK Customer Service.

### 10.3 Device not functioning

Table 10: Device not functioning

Possible causes	Action
Power supply not connected.	1 Check power cable and connections.
Power supply has failed.	► Check power supply (e.g. socket, external disconnecting device).
Internal operating temperatures not correct.	1 Check whether error messages exist.
Internal software not functioning.	Can only occur with complex internal malfunctions or after strong external influences (e.g., strong electromagnetic interfering pulse). 1 Switch the GM32 off and on again after a few seconds.
Ex control unit does not switch on.	1 Protective gas feed interrupted or too low. 2 Ex control unit indicates an error (see Pressurized Enclosure System Manual).

### 10.4 Overpressure monitoring failure

Failure of the control unit triggers the display of an alarm signal. There is no automatic switch-off.



#### NOTE

See Pressurized Enclosure System Manual.

## 10.5 Measured values clearly incorrect

Table 11: Measured values clearly incorrect

Possible errors	Possible causes	Action
Sample gas penetrates the area before the SR-unit.	<ul style="list-style-type: none"> <li>Gas pressure in gas duct too high.</li> <li>Purge air unit has failed or is too weak</li> </ul>	see "Sample gas penetrating", page 78.
Sample gas penetrates the purge air compartment.	<ul style="list-style-type: none"> <li>The gas pressure in the gas duct is too high</li> <li>Purge air unit has failed or is too weak</li> </ul>	see "Sample gas penetrating", page 78.
Sample gas conditions do not match, or no longer match, project planning	<ul style="list-style-type: none"> <li>Plant condition has changed</li> </ul>	▶ Check sample gas conditions (temperature, moisture, concentration etc.).
The device is not ready for operation.	--	<ul style="list-style-type: none"> <li>▶ Check start-up</li> <li>▶ Check status/error messages.</li> </ul>
The device is not adjusted correctly.	--	<ul style="list-style-type: none"> <li>▶ Check:                             <ul style="list-style-type: none"> <li>- Were correct test gases used?</li> <li>- Are setpoint values correct?</li> </ul> </li> <li>▶ If the answer to both questions is "Yes", contact SICK Service to have a calibration performed.</li> </ul>
Analyzer is contaminated.	--	▶ Report to manufacturer's Technical Service or trained skilled persons.

## 10.6 Sample gas penetrating

Table 12: Sample gas penetrating

Possible errors	Possible causes	Action
Sample gas penetrates the area before the SR-unit.	<ul style="list-style-type: none"> <li>The gas pressure in the gas duct is too high</li> </ul>	▶ Check project planning.
	<ul style="list-style-type: none"> <li>Purge air unit has failed or is too weak</li> </ul>	<ul style="list-style-type: none"> <li>▶ Check purge air unit.</li> <li>▶ Provide redundant purge air unit.</li> <li>▶ Strengthen the purge air unit.</li> </ul>

## 10.7 Corrosion on flange

Table 13: Corrosion on flange

Possible errors	Possible causes	Action
Corrosion on flange.	Unsuitable materials	▶ Check project planning.

## 10.8 Measured value blinks

Measured value blinks = "uncertain measured value", e.g. a calibration range was exceeded.

## 10.9 Error messages

### 10.9.1 Example of an error message

The error message displayed here is shown on the device display of the in-situ gas analyzer GM32 Ex. Refer to the SOPAS Manual for the display via SOPAS ET.

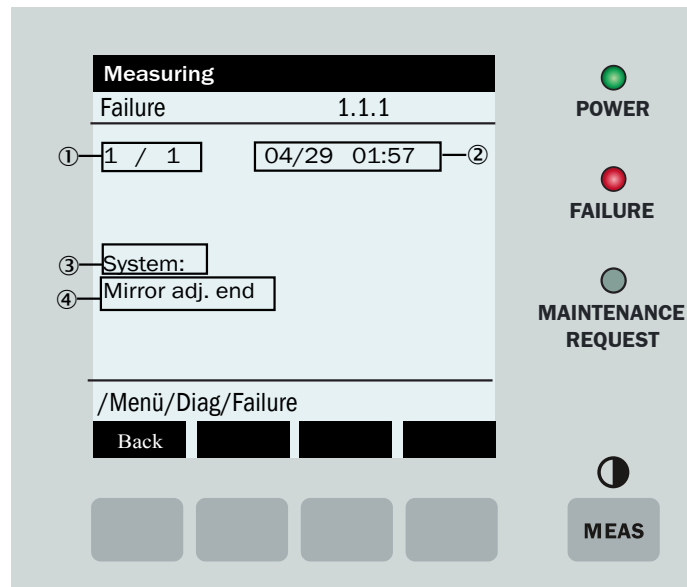

Figure 40: Error message display

- ① Message number / number of messages
- ② Date (dd/mm) time (hh:mm:ss)
- ③ Initiator
- ④ Error message



#### NOTE

All error messages are listed in a Table, see Chapter Error Messages.  
The definition of “Initiator” is shown at the end of the Table.

10.9.2 Error messages

Table 14: Error table: Malfunction message

Initiator	Text	Classification	Description	Possible causes/remedy
System	EEPROM	Failure	EEPROM parameters corrupted or not compatible after software upgrade.	<ul style="list-style-type: none"> <li>Software upgrade: Reset parameters. Load saved parameters</li> <li>Defect: Reload backup. Possibly replace hardware.</li> </ul>
	Spectro com.	Failure	Communication fault with spectrometer.	Error in I2C connection with spectrometer. Plug connector / check for hardware defect.
	Zero com.	Failure	Communication fault with zero point reflector.	Error in I2C connection with zero point reflector. Plug connector / check for hardware defect.
	Temp control com.	Failure	Communication fault with temperature control unit.	Error in I2C connection. Plug connector / check for hardware defect.
	Visor com.	Failure	Communication fault with visor module.	Error in I2C connection with visor module. Plug connector / check for hardware defect.
	Filter com.	Failure	Communication fault with control filter element.	Error in I2C connection with control filter element. Plug connector / check for hardware defect
	Mirror com.	Failure	Communication fault with mirror tracking.	Error in I2C connection with mirror tracking. Plug connector / check for hardware defect.
	Lamp com.	Failure	Communication fault with lamp electronics.	Error in I2C connection with lamp electronics. Plug connector / check for hardware defect.
	Visor fault	Failure	Error of visor signals. Signal distorted or zero.	Check signals and parameters.
	Visor values	Failure	Visor signals outside the valid range.	Hardware defect. Electronics not adjustable (amplification too high).
	Visor no signal	Failure	All 4Q signals below threshold parameter.	Check alignment, reflector, contamination.
	Lamp fault	Failure	Lamp does not go on.	Lamp is defective. Replace lamp, see <a href="#">"Replacing the sender lamp"</a> , page 72.
	Mirror adj. End	Failure	Mirror tracking has reached maximum position.	Check alignment, see <a href="#">"Alignment check (option) - automatic optical alignment check"</a> , page 60.
	Zero adj. mc adj.	Failure	Beam tracking during adjustment not possible.	
	Spectro para.	Failure	No correct parameters saved in spectrometer.	Please contact SICK Customer Service.
	Purge air signal	Failure	Digital input signals purge air error.	Check purge air supply.
	Temp control out of range	Failure	Temperature regulation measurement outside the valid range.	Excess temperature switch-off active for temperatures > 70 °C. Switches back on automatically when < 65 °C.
	Extinction calc	Failure	Error in extinction calculation.	Please contact SICK Customer Service.
	Reference calc	Failure	Error in reference calculation.	
	IIR Filter	Failure	Error during IIR filtering.	
Interpolation	Failure	Error in interpolation calculation.		
Eval modul com.	Failure	Error in communication with software evaluation module.		
File conditions	Failure	Error during condition file access.		
File espec	Failure	Error during extinction file access.		
File cact	Failure	Error during lambda coefficient file access.		
File measval	Failure	Error during measured value file access.		



Table 15: Error table: Maintenance request

Initiator	Text	Classification	Description	Possible causes/remedy
System	Lamp performance	Maint.	Warning: Lamp performance < 20%.	Prepare to exchange the lamp, see "Replacing the sender lamp", page 72.
	Lamp performance limit	Maint.	Lamp performance too low.	
	Lamp minimum	Maint.	Lamp adjustment: Signal too high for minimum lamp current and exposure.	Check parameter settings.
	Lamp 4Q max	Maint.	The lamp current must be set to 1000 mA (stop) in the alignment procedure.	<ul style="list-style-type: none"> <li>Alignment, check the optics, see "Alignment check (option) - automatic optical alignment check", page 60.</li> <li>Possible lamp change, see "Replacing the sender lamp", page 72.</li> <li>Correct parameter settings.</li> </ul>
	Flashcard missing	Maint.	No Flashcard found.	Insert the Flashcard, replace a possibly defective card.
	IO com.	Maint.	Communication fault to IO block.	<ul style="list-style-type: none"> <li>Connection interrupted, check the cable.</li> <li>CAN-bus interface defective.</li> </ul>
	Spectro no answer	Maint.	No data received from spectrometer.	Malfunction on the interface to the spectrometer. Check the plug.
	Cycle span drift	Maint.	The measurement on the control filters showed a deviation that is too high.	The reference from the adjustment is not correct. Check limit value parameter setting.
	Cycle zero drift	Maint.	The zero point measurement of a measured value showed an excess deviation.	Check limit value parameter setting.
	Cycle wavelength drift	Maint.	The check of the current Lambda_CO coefficient showed an excess deviation.	
	Cycle peak position	Maint.	The check of the position of the peak of the NO cell showed an excess deviation	
	Cycle peak width	Maint.	The check of the peak width of the NO cell showed an excess deviation.	Cell is empty.
	Cycle cell empty	Maint.	During the check of the NO cell it is determined that the highest measured extinction value in the evaluation range is <0.1.	
	Temp control voltage low	Maint.	The measured voltage supply value is too small (< 20 V).	Malfunction of temperature control unit.
	Temp control lamp fan	Maint.	The lamp fan has a malfunction.	Malfunction: <ul style="list-style-type: none"> <li>Temperature control unit</li> <li>Fan</li> <li>Cabling</li> </ul>
	Temp control optic fan	Maint.	The fan of the optic carrier has a malfunction.	
	Temp control spectro fan	Maint.	The fan of the spectrometer has a malfunction.	
	Temp control electronic temp	Maint.	Temperature of the temperature control electronics >100 °C.	Malfunction of temperature control unit.
	Temp control spectro temp	Maint.	SR-unit is too warm or too cold.	<ul style="list-style-type: none"> <li>In the heating phase: Normal.</li> <li>When running: Check ambient temperature.</li> </ul>
	Data logging: writing data	Maint.	Error when writing logging data to the Flashcard.	Flashcard memory full, Flashcard defective.
Data logging: open file	Maint.	Error when opening a file for logging data on the Flashcard.		
System I/O Error	Maint.	Error in "Modular I/O System".	Incorrect configuration of I/O module or I/O module defective.	

Table 16: Error table: Maintenance request / Xtended

Initiator	Text	Classification	Description	Possible causes/remedy
CDR/CDH	EL. too hot	Maint.	Electronics too hot.	<ul style="list-style-type: none"> <li>Allow device to cool down.</li> <li>Ambient temperature too high?</li> </ul>
	Air purge low	Maint.	Volume flow below set limit.	Check purge air supply.
	Filter watch	Maint.	Flow monitor.	
	p no signal	Maint.	No signal from pressure sensor.	
	p out of range	Maint.	Sample gas pressure < 500 or > 1200 hPa (mbar).	--
	t air no signal	Maint.	Broken sensor.	Please contact SICK Customer Service.
	[t] no signal	Maint.		
	EEPROM defect	Maint.	EEPROM defective.	
	Heat no signal	Maint.	Heater fault.	
	Heater < 1.5 A	Maint.	Visor signals outside the valid range.	
	Heater defect	Maint.	All 4Q signals below threshold parameter.	
	Heating too low	Maint.	Lamp does not go on.	
	No com.	Maint.	Communication error to optic head and/or reflector.	Communication error to optic head and/or reflector.
System	Systemstart	Xtended	This message is entered during each system start.	Shows when the last system start was made.
	Zero adjust	Xtended	The start of an adjustment is recorded in the logbook.	Shows when the last adjustment was made.
	Boxmeasuring	Xtended	The start of filter box measurement is recorded in the logbook.	Shows when last filter box measurement was made.
	Reflector search	Xtended	Search for reflector failed.	<ul style="list-style-type: none"> <li>Check alignment, see "<a href="#">Alignment check (option) - automatic optical alignment check</a>", page 60.</li> <li>Reflector contaminated or defective.</li> <li>Light intensity weakness too strong on measuring path.</li> </ul>
P	Substitute value	Maint.	Calculation is made with a substitute value because of a pressure measurement error.	
T		Maint.		
H		Maint.		

Table 17: Error table: Failure / Xtended / Uncertain

Initiator	Text	Classification	Description	Possible causes/remedy
Gas component	Bad Config. (text)	Failure	Error in calculation models.	Please contact SICK Customer Service.
	File I/O (text)	Failure	Error in file system.	<ul style="list-style-type: none"> <li>Restart system. If the error continues to exist:</li> <li>Please contact SICK Customer Service.</li> </ul>
	Measurement range x	Xtended.	Current measuring range x ( x = 1 ... 8).	--
	Measurement value out of range	Uncertain	Measured value outside calibration range.	Check measured values for plausibility.
	Measurement value range warning	Xtended	Measurement beyond a warning threshold defined during calibration.	
	Medium pressure out of range	Uncertain	Sample gas pressure outside calibrated range.	Check sample gas pressure.
	Medium pressure warning	Xtended	Sample gas pressure beyond warning threshold.	
	Medium temperature out of range	Uncertain	The measurement on the control filters showed a deviation that is too high.	Check sample gas temperature.
	Medium temperature warning	Xtended	The check of the position of the peak of the NO cell showed an excess deviation.	
	Absorption range warning	Xtended	<ul style="list-style-type: none"> <li>Absorption in active measuring path above warning threshold.</li> <li>Standard setting of warning threshold: 1,8 extinction units.</li> </ul>	Check:
	Absorption out of range	Failure		<ul style="list-style-type: none"> <li>Window dirty? see "<a href="#">Cleaning the window</a>", page 70.</li> <li>Dust content in sample gas too high?</li> <li>Sample gas concentration too high?</li> </ul>
	Syntax error	Failure	Error in concentration calculation.	Please contact SICK Customer Service.
	Processing error	Failure		
	Numerical (Div-Zero)	Failure		
	Numerical (IppError)	Failure		
	Numerical (MatSing)	Failure		
OS error (text)	Failure	Error in operating system.	<ul style="list-style-type: none"> <li>Restart system. If the error continues to exist:</li> <li>Please contact SICK Customer Service.</li> </ul>	
Spectr. resolution out of range	Failure	Resolution of spectrometer wrong.	Please contact SICK Customer Service.	
Spectral evaluation	Uncertain	Error in calculation of spectra.		

Table 18: Initiator key

System	SR-unit
CDH	Purge air fixture on SR side
CDR	Purge air fixture on reflector side
P	Pressure sensor
T	Temperature sensor
	Gas component

 **NOTE**  
This Table also contains recommended solutions that can only be performed by specially trained personnel.

### 10.10 Repairing inadequate purge air supply

---



**WARNING**  
**Risk of explosion**

Some of the work described in this Chapter assumes an Ex free zone.

- ▶ Wait 20 minutes after switching off the main power supply before opening the enclosure.
- 



**CAUTION**  
**A faulty purge air supply can damage the measuring system**

The measuring system can no longer be protected from contaminated sample gas and is damaged.

- ▶ When the purge air supply appears faulty, immediately perform all actions described in these Operating Instructions.
- 

#### Indications of insufficient purge air supply

- Unusual noises from the area of the purge air supply
- On systems with pressure difference sensor: An appropriate error message occurs
- Rise in enclosure temperature
- Unusually rapid contamination of the window of the measuring device

#### Information for fast correction of faults

- Air filter of purge air unit clogged?
- Purge air hose slipped off or broken?
- Power supply of the purge air unit failed?

#### Check the purge air unit

- ▶ Pull the purge air hose on the SR-unit: A strong air flow must be noticeable.
- ▶ Reinstall the purge air hose immediately.

#### Measures for insufficient purge air supply

- If the purge air unit is not immediately functional:
  - ▷ Remove the SR-unit and reflector unit from the gas duct.
- For a short malfunction:
  - ▷ Swiveling out the SR-unit and reflector unit is sufficient.
- Bring the purge air unit back to correct operation immediately
- Replace provisionally with a different purge air supply with at least the same purge air throughput

### 10.11 Malfunctions on the connection unit

A green LED lights on each of the power supply units in the connection unit. If no LED lights:

- ▶ Check the power supply of the connection unit.  
Contact SICK Customer Service when power supply present.

## 11 Decommissioning

### 11.1 Safety information on shutting down

#### Technical knowledge needed / requirements for decommissioning

---



#### NOTICE

- You are basically familiar with GM32.
- You are well versed in the ATEX Directives.
- You are familiar with the local situation, especially the potential hazards caused by gases in the gas duct (hot/noxious). You are capable of recognizing and preventing danger by possibly escaping gases.

If one of these requirements is not met:

- ▶ Please contact SICK Customer Service or your local representative.
- 

#### UV radiation

---



#### DANGER

##### Damage to eyes and skin by UV radiation

The in-situ gas measuring device GM32 emits UV radiation when the SR-unit or reflector unit is opened during operation. Exposure of the unprotected skin and eyes to radiation is dangerous to health.

- ▶ Disconnect the power supply of the device before opening the device.
  - ▶ Wear suitable protective goggles and protective gloves when work on the open device with the power supply connected is performed.
- 



#### DANGER

##### Damage to eyes and skin by UV radiation

The in-situ gas measuring device GM32 emits UV radiation when the SR-unit or reflector unit is opened during operation. Exposure of the unprotected skin and eyes to radiation is dangerous to health.

- ▶ Disconnect the power supply of the device before opening the device.
  - ▶ Wear suitable protective goggles and protective gloves when work on the open device with the power supply connected is performed.
- 

#### Risk of explosion

---



#### DANGER

##### Risk of explosion through residual voltages and hot surfaces in the device

When the device is switched off, residual voltages and hot surfaces represent an increased risk of explosion when the device is open.

- ▶ Wait 20 minutes after switching off the main power supply before opening the enclosure.
-

### Gas



#### **DANGER**

##### **Danger to life by leaking hot/toxic gases**

Hot and/or noxious gases can escape during work on the gas duct, depending on the plant conditions.

- ▶ Work on the gas duct may only be performed by skilled technicians who, based on their technical training and knowledge as well as knowledge of the relevant regulations, can assess the tasks given and recognize the hazards involved.
- 



#### **WARNING**

##### **Risk to health through contact with toxic gases**

The modules and equipment contain enclosed, potentially dangerous gases that can escape should a defect or leak occur. Should a leak occur, the concentrations within the enclosed equipment can rise up to 40 ppm.

- NO: 2 ml maximum total volume
  - ▶ Only open the device when good ventilation is available, especially when a leak of one of the device components is suspected.
- 



#### **WARNING**

##### **Risk to health through contact with hot and/or aggressive sample gases**

There is a risk of contact with noxious sample gases when working on an open measuring duct.

- ▶ Observe the valid regulations concerning protective equipment during operation during all work on the device.
  - ▶ Never open the enclosure or switch off the purge air feed without taking appropriate protective measures when the duct is pressurized.
- 



#### **DANGER**

##### **Risk to health through contaminated measuring device**

Toxic residues may be present in acidic process gas on the measuring device after operation.

- ▶ Always wear the specified protective clothing.
- 

### Electricity

Observe all safety information in the Commissioning and Electrical Installation Chapters: see "[Electrical installation safety information](#)", page 32 and see "[Safety information for start-up](#)", page 45.

### Device damage



#### **CAUTION**

##### **Risk of device damage caused by switching off the purge air too soon**

If the purge air is switched off when the SR-unit or the reflector are still in the gas duct, hot and contaminated gas can cause a device damage.

- ▶ Switch off the purge air unit only after removal of the SR-unit from the gas duct.
-

## 11.2 Decommissioning of subassemblies with explosion relevance

### GM32 Ex category 3G

- ▶ Disconnect the GM32 Ex from the main power supply.
- ▶ Disconnect the Ex control unit from the mains.



#### NOTE

The analyzer can remain on the gas duct as long as the optics purge air supply is in operation.



#### CAUTION

##### Device damaged caused by unnoticed purge air failure

After the GM32 Ex has been disconnected from the mains, there will be no message via the analyzer when the purge air supply fails. There is a risk of contamination on the optics.

- ▶ Install suitable monitoring (provided by the customer)  
or
- ▶ remove the respective subassemblies.

## 11.3 Removing the device

Material required	Part No.	Required for
Flange cover	--	Covering the flange
Personal protective equipment	--	Protection when working on the stack or hot or aggressive sample gases

### Removing the measuring system

- 1 Disconnect all connections between connection unit and SR-unit or reflector unit.
- 2 Remove the SR-unit or reflector unit or reflector unit, see ["Swiveling out and removing the SR-unit or reflector unit"](#), page 68.



#### CAUTION

- Observe the information concerning removal of the SR-unit, see ["Swiveling out and removing the SR-unit or reflector unit"](#), page 68.

- 3 Unscrew and remove the device flanges as required.
- 4 Unscrew and remove the purge air fixtures on the flanges as required.
- 5 Switch the purge air supply off and remove the purge air hoses from the device flanges.
- 6 Close the flanges on the gas duct with a lid.

Information on storage, see ["Storage"](#), page 23.

## 11.4 Environmentally compatible disposal

The device should be disposed as industrial waste.



#### NOTICE

- ▶ Observe relevant local conditions for disposal of industrial waste.



### **WARNING**

**Disposal of subassemblies containing residual substances which are harmful to the environment**

The following subassemblies could contain substances that have to be disposed of separately:

- Electronics: Capacitors, rechargeable batteries, batteries
  - Display: Liquid of LC-Display
-



## 12 Technical data

### 12.1 System: GM32 Ex

<b>Description</b>	Performance-tested In-situ Gas Analyzer for emission monitoring and process measurement
<b>Measured variable</b>	NO, NO <sub>2</sub> , NH <sub>3</sub> , SO <sub>2</sub>
<b>TÜV-tested measured variable</b>	NO, SO <sub>2</sub>
<b>Maximum number of measured variables</b>	4 (plus process temperature and pressure).
<b>Measuring principle</b>	Differential Optical Absorption Spectroscopy (DOAS)
<b>Measuring ranges</b>	<ul style="list-style-type: none"> <li>• NH<sub>3</sub>: 0 ... 30 ppm / 0 ... 2,600 ppm</li> <li>• NO: 0 ... 40 ppm / 0 ... 1,900 ppm</li> <li>• NO<sub>2</sub>: 0 ... 50 ppm / 0 ... 1,000 ppm</li> <li>• SO<sub>2</sub>: 0 ... 15 ppm / 0 ... 7,000 ppm</li> </ul> <p>The measuring ranges refer to a 1 m measuring path. Measuring ranges depending on application and device version.</p>
<b>Certified measuring ranges</b>	<ul style="list-style-type: none"> <li>• NO: 0 ... 70 mg/m<sup>3</sup> / 0 ... 700 mg/m<sup>3</sup></li> <li>• SO<sub>2</sub>: 0 ... 75 mg/m<sup>3</sup> / 0 ... 1,00 mg/m<sup>3</sup></li> </ul> <p>With an active measuring path length of 1.86 m (Cross-Duct)</p>
<b>Response time</b>	<ul style="list-style-type: none"> <li>• ≥ 30 s adjustable</li> <li>• TÜV-tested for suitability: ≥ 30 s, adjustable</li> </ul>
<b>Precision</b>	<ul style="list-style-type: none"> <li>• NH<sub>3</sub>: ± 0.7 ppm</li> <li>• NO: ± 0.8 ppm</li> <li>• NO<sub>2</sub>: ± 2.5 ppm</li> <li>• SO<sub>2</sub>: ± 0.3 ppm</li> </ul> <p>Relative to the smallest measuring range</p>
<b>Ambient temperature</b>	-20 °C ... +55 °C, temperature change maximum ± 10 °C/h
<b>Process gas temperature</b>	<ul style="list-style-type: none"> <li>• Max. +400 °C when using the p/T sensor recommended by SICK</li> <li>• Max. + 550 °C when using suitable p/T sensors</li> </ul> <p>⚠ Observe intrinsically safe connection values!</p>
<b>Storage temperature</b>	-20 °C ... +55 °C, temperature change maximum ± 10 °C/h
<b>Process gas pressure</b>	-60 hPa ... +60 hPa
<b>Ambient humidity</b>	≤ 96% relative humidity; moisture condensation on optical interfaces not allowed
<b>Conformities</b>	<p>Approved for plants requiring approval:</p> <ul style="list-style-type: none"> <li>• 2001/80/EC (13th BImSchV)</li> <li>• 2000/76/EC (17th BImSchV)</li> <li>• 27th BImSchV</li> <li>• EN 14181</li> <li>• EN 15267-3</li> </ul>

<b>Directives / Standards</b>	2014/34/EU ATEX <ul style="list-style-type: none"> <li>IEC / EN 60079-0:2011/2012</li> <li>IEC / EN 60079-2:2014/2014</li> <li>IEC / EN 60079-11:2011/2012</li> <li>IEC / EN 60079-28:2015/2015</li> </ul> 2014/30/EU EMC <ul style="list-style-type: none"> <li>IEC / EN 61326-1:2012/2013</li> </ul> 2014/35/EU Low Voltage Directive <ul style="list-style-type: none"> <li>IEC / EN 61010-1:2010/2010</li> </ul> Other standards used: <ul style="list-style-type: none"> <li>EN 60068</li> </ul>
<b>Ex certifications</b>	3G / Zone 2: Connection unit and sender/receiver unit ATEX GM32 Ex 3G <ul style="list-style-type: none"> <li>Ⓔ II 3G Ex pzc op is [ia] IIC T3 Gc</li> </ul> IECEx GM32 Ex 3G <ul style="list-style-type: none"> <li>Ex pzc op is [ia] IIC T3 Gc</li> </ul> Special conditions (X identification) <ul style="list-style-type: none"> <li>A measuring function for explosion protection is not part of the EC type approval</li> <li>The duct with sample gas contact must be a non-potentially explosive atmosphere when overpressure against the atmosphere is present in the duct</li> <li>If the duct has underpressure against the atmosphere, this area may correspond to Zone 2</li> </ul>
<b>Directives / Standards</b>	CE
<b>Degree of protection</b>	IP 65
<b>Operation</b>	Via integrated control unit or SOPAS ET software
<b>Correction functions</b>	Internal contamination correction
<b>Control functions</b>	<ul style="list-style-type: none"> <li>Internal zero point control</li> <li>Check cycle for zero and reference point according to QAL</li> </ul>
<b>Options</b>	Control unit SCU ⚠ Only for installation in Ex-free zone
<b>Scope of delivery</b>	The scope of delivery is dependent on the application and the customer specification

## 12.2 GM32 Ex sender/receiver unit

<b>Description</b>	Analyzer unit of measuring system
<b>Interfaces</b>	Ethernet (service and OPC interface)
<b>Operation</b>	Via integrated control unit
<b>Dimensions</b>	315 mm x 910 mm x 410 mm
<b>Weight</b>	≤ 20 kg

## 12.3 Reflector unit GM32 Ex

<b>Description</b>	Reflector unit with glass triple reflector
<b>Process temperature</b>	≤ 550 °C , versions for higher temperatures on request
<b>Process pressure</b>	-60 hPa ... 200 hPa

<b>Dimensions</b>	291 mm x 280 mm x 161 mm
<b>Weight</b>	≤ 9 kg

**12.4 Purge air fixture: Sender/receiver unit GM32 Ex**

<b>Description</b>	Flange attachment with connections for purge air and purge air monitoring
<b>Dimensions</b>	320.9 mm x 360 mm x 220 mm (see dimension drawings for details)
<b>Weight</b>	≤ 7 kg
<b>Connections for auxiliary substances</b>	Purge air

**12.5 Purge air fixture: Reflector unit GM32 Ex**

<b>Description</b>	Flange attachment with connections for purge air and purge air monitoring
<b>Bus protocol</b>	CAN (internal system bus)
<b>Dimensions</b>	320.9 mm x 360 mm x 220 mm (see dimension drawings for details)
<b>Weight</b>	≤ 7 kg
<b>Connections for auxiliary substances</b>	Purge air

**12.6 Connection unit, Ex version I/O module**

<b>Description</b>	Serves for on-site connection of the power supply and of data and signal cables
<b>Analog outputs</b>	2 outputs: 0/4 ... 22 mA, 500 Ω Per module, modules can be selected and extended as required
<b>Analog inputs</b>	2 inputs: 0/4 ... 22 mA, 100 Ω Per module, modules can be selected and extended as required
<b>Digital outputs</b>	4 outputs: 48 V AC/DC, 0.5 A, 25 W Per module, modules can be selected and extended as required
<b>Digital inputs</b>	4 inputs: 3.9 V, 4.5 mA, 0.55 W Per module, modules can be selected and extended as required
<b>Interfaces</b>	Ethernet via fiber optical cable Extendable via external control unit (option)
<b>Bus protocol</b>	<ul style="list-style-type: none"> <li>• OPC</li> <li>• Ethernet TCP/IP (only via fiber optic cable connection)</li> </ul>
<b>Dimensions (W x H x D)</b>	679 mm x 630 mm x 158 mm
<b>Weight</b>	≤ 16 kg

**Electrical connection**

- Voltage: 115 V or 230 V (application-specific)
- Frequency: 50 Hz / 60 Hz
- Power input: ≤ 260 W

**12.7 Dimension drawings: Sender/receiver unit Ex version**

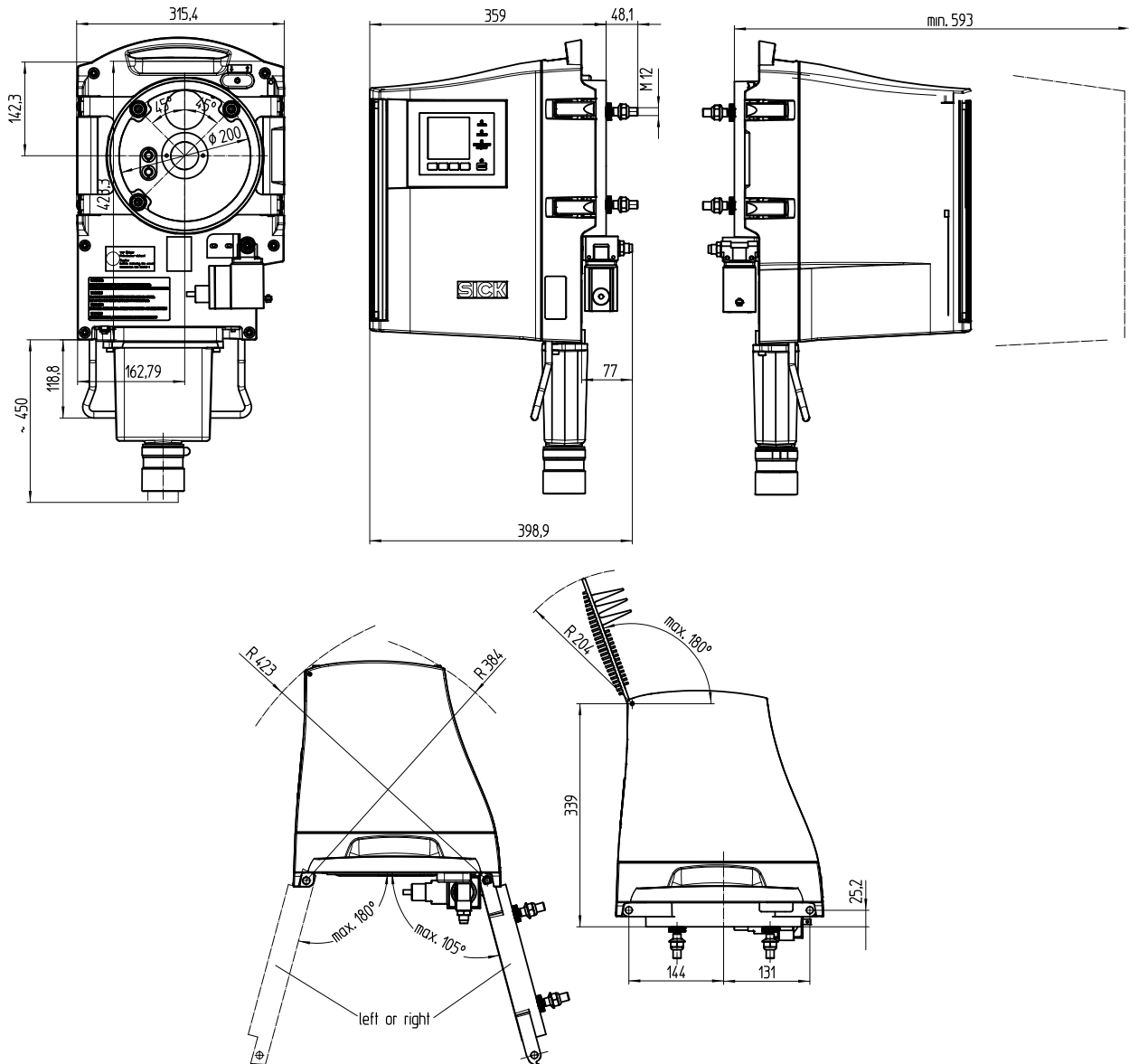

Figure 41: GM32 Ex sender/receiver unit (all specifications in mm)



**NOTE**

The housing of the sender/receiver unit can be swiveled to the left or right of the device flange (max. 180°/105°).

12.8 Dimension drawings: Reflector unit

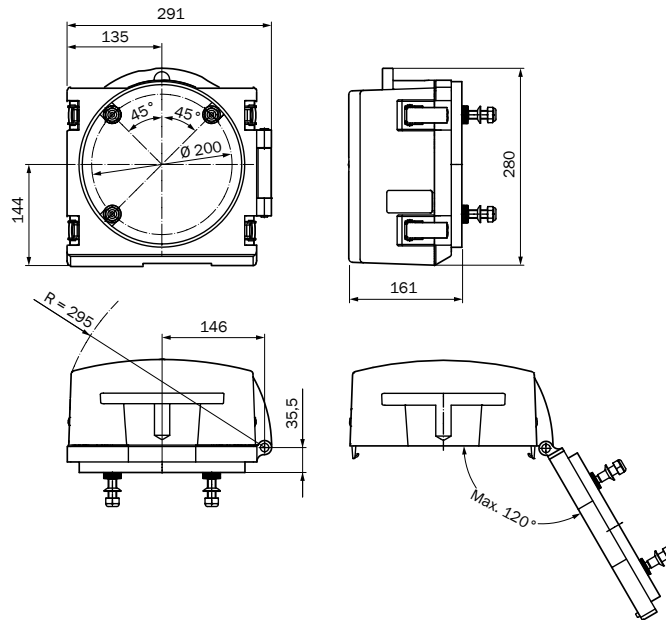

Figure 42: GM32 Ex reflector (all specifications in mm)

Flange – flange distance [in m]	Reflector part number
0.4 ... 0.7	2046732
0.7 ... 1.2	2046731
1.2 ... 1.7	2046730
1.7 ... 2.0	2046729
2.0 ... 2.5	2046728
2.5 ... 3.0	2046721
3.0 ... 4.0	2046734
4.0 ... 5.0	2046735
5.0 ... 6.0	2046794
6.0 ... 7.0	2046838
7.0 ... 8.0	2046852
8.0 ... 10.0	2046854
10.0 ... 12.0	2046858

12.9 Dimension drawings: Ex purge air fixtures (on SR and reflector side)

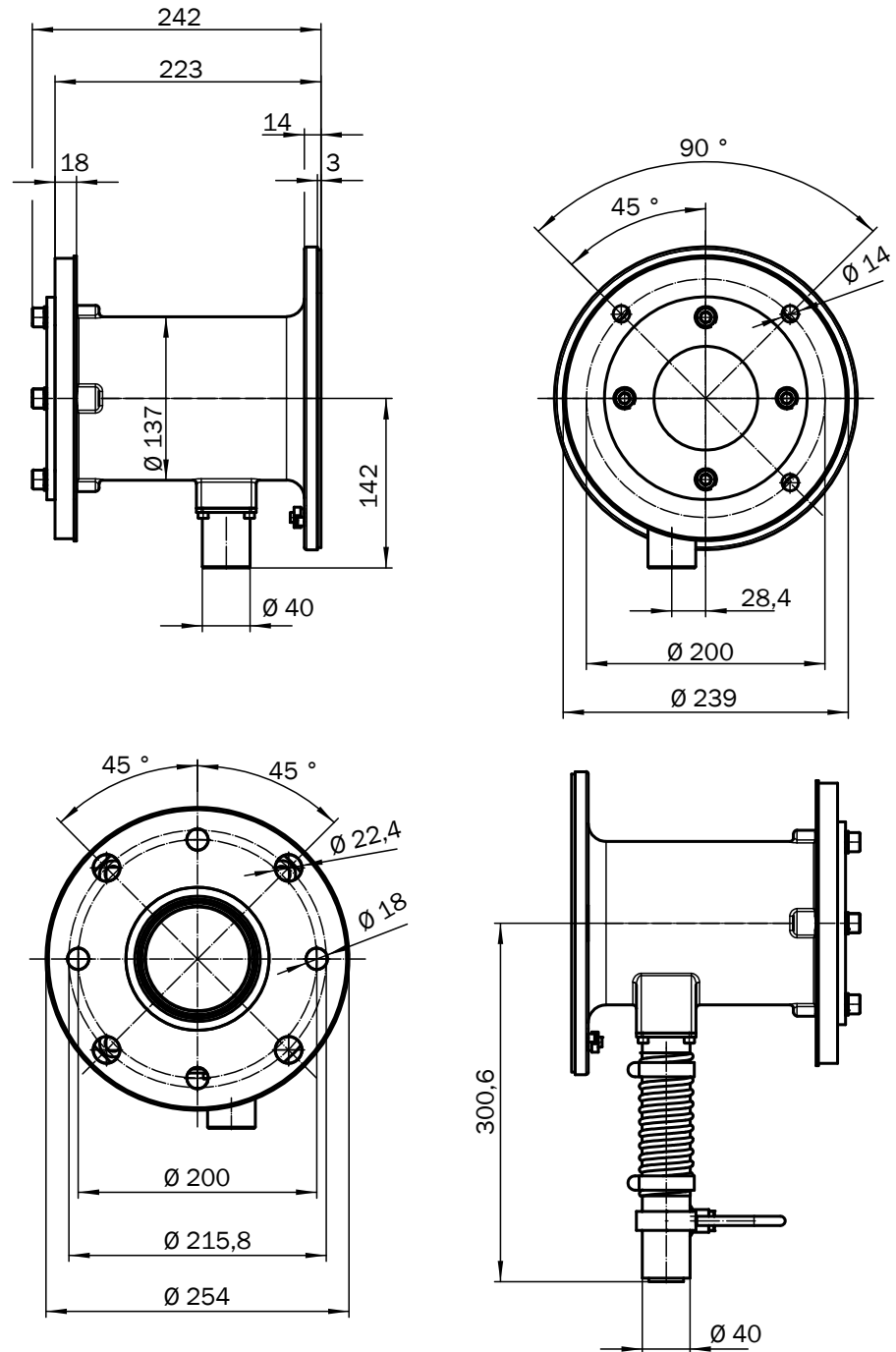

Figure 43: GM32 Ex purge air fixtures, on SR and reflector side (all specifications in mm)

12.10 Dimension drawings: Connection unit version 3G

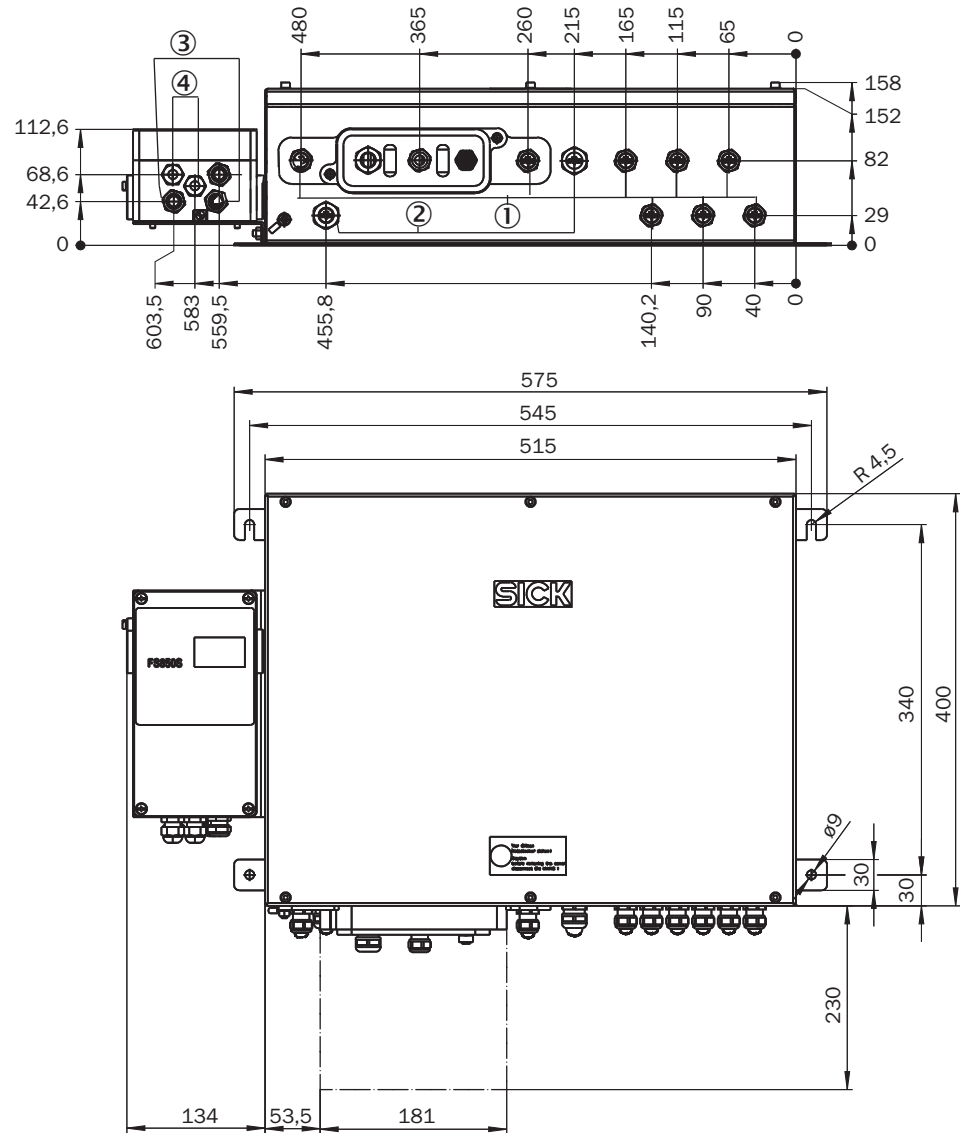

Figure 44: Connection unit version 3G (all specifications in mm)

No.	Line opening size	Line diameter (clamping range)	Number
①	M16 x 1.5	5 - 11 mm	8
②	M20 x 1.5	10 - 14 mm	2
③	M16 x 1.5	5 - 11 mm	3
④	M16 x 1.5	4 - 8 mm	2

12.11 Dimension drawings: Mounting flange DN100

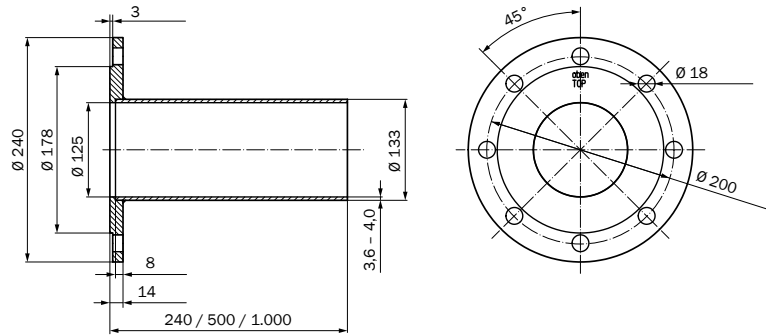

Figure 45: Mounting flange DN100 (all specifications in mm)

12.12 Dimension drawing, weatherproof cover, SR-unit

Weatherproof cover for sender/receiver unit

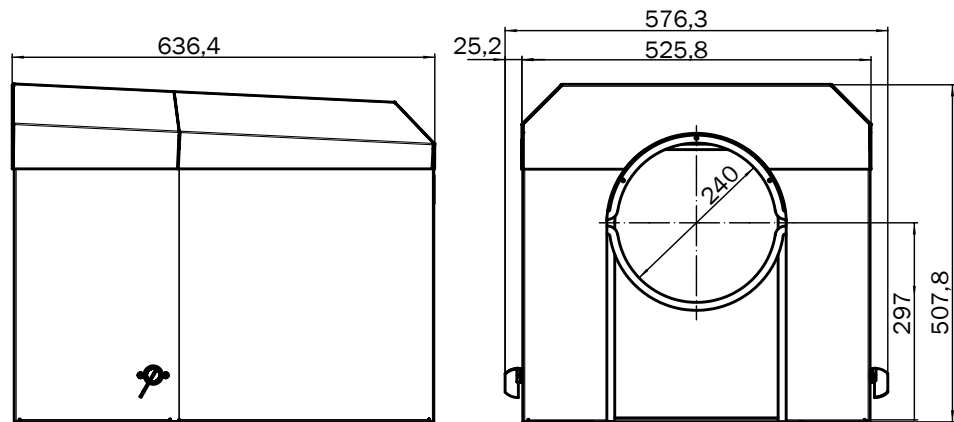

Figure 46: Weatherproof cover for sender/receiver unit (all specifications in mm)

12.13 Technical data for enclosure pressurization system

12.13.1 Technical data protective gas

Protective gas

Table 19: Technical data protective gas

Protective gas	Compressed air, class 533 according to ISO 8573-1 Solid matter 40 µm (class 1) Pressure dew point ≤ 20 °C (class 3) Oil quality ≤ 0.01 mg/m <sup>3</sup> (class 1)
Connections	
• Inlet	• Thread G 3/8" or • Hose connection for 8 mm diameter
• Outlet	Thread G 1"



• Consumption	Max. 0.6 l/min
Inlet temperature	-20 ... +40 °C (-4 ... +104 °F)
Primary pressure	
• Max.:	2500 hPa (2.5 bar) (36 psi) (relative)
• Min.:	2000 hPa (2 bar) (30 psi) (relative)

**12.13.2 Technical data enclosure**

Free volume:	40 l (2440 in3)
Minimum overpressure:	80 Pa (0.8 mbar) (0.012 psi) (relative)
Maximum overpressure:	1800 Pa (18 mbar) (0.26 psi) (relative)

**Prepurging during start-up**

Typical pre-purge time:	Approx. 6 minutes
-------------------------	-------------------

**12.13.3 Pressurized enclosure system settings**



**WARNING**

**Risk of explosion through incorrect parameter settings**

Unauthorized changing of parameters can cause an explosion with fatal consequences.

- ▶ Never change parameters without authorization.

Enclosure pressurization system used: Gönheimer FS850S for use in Ex zone 2.

FS850S parameters	Setting
Valve control	Proportional valve (P-valve)
Operating mode	Leakage compensation (purging not continuous)
Purge volume, pre-purge	500 l (30000 in <sup>3</sup> )
Nominal purge pressure	10 mbar (0.145 psi) (relative)
Minimum pressure in enclosure	0.8 mbar (0.012 psi) (relative)
Maximum pressure in enclosure	18 mbar (0.26 psi) (relative)
Nominal pressure in enclosure	2 mbar (0.03 psi) (relative)
Signal pressure	1.5 mbar (0.022 psi) (relative)

## 13 Annex

### 13.1 Conformities

GM32 Ex complies with the following directives and standards:

Table 20: Applied EN standards for measuring systems

EN standard	Application
EN 14181	Calibration of continuously operating emission measuring instruments
EN 15267-3	Part 3 - Certification of automatic measuring systems
EN 60068	Shock and vibration

Table 21: Ex-relevant directives and standards

Directive	Harmonized standard	Application
2014/34/EU ATEX	IEC / EN 60079-0:2011/2012	General requirements
	IEC / EN 60079-2:2014/2014	Pressurized enclosure Ex-p
	IEC / EN 60079-11:2011/2012	Protection through intrinsic safety Ex i
	IEC / EN 60079-28:2015/2015	Optical radiation
2014/30/EU EMC	IEC / EN 61326-1:2012/2013	EMC for electrical measuring devices
2014/35/EU Low Voltage Directive	IEC / EN 61010-1:2010/2010	Safety requirements for electrical equipment for measurement, control, and laboratory use
	EN 60529:1991+ A1:2000 + A2:2013	Degrees of protection provided by enclosures (IP code)

### 13.2 Electrical protection

- Device corresponds to protection class 1 and requires a protective grounding (PE) in accordance with EN 61140
- Overvoltage protection in accordance with EN 61010-1
- Contamination: The control unit operates safely in an environment up to contamination level 2 in accordance with EN 61010-1 (usual, non-conductive contamination and temporary conductivity by occasional moisture condensation)

### 13.3 Ex certifications



3G / Zone 2: Connection unit and sender/receiver unit

ATEX GM32 Ex 3G

-  II 3G Ex pzc op is [ia] IIC T3 Gc



IECEx GM32 Ex 3G

- Ex pzc op is [ia] IIC T3 Gc

Special conditions (X identification)

- A measuring function for explosion protection is not part of the EC type approval
- The duct with sample gas contact must be a non-potentially explosive atmosphere when overpressure against the atmosphere is present in the duct
- If the duct has underpressure against the atmosphere, this area may correspond to Zone 2

## 14 Index

<b>A</b>	
Adjusting.....	50
adjustment tube .....	49
<b>B</b>	
Brightness.....	58
<b>C</b>	
Check cycle.....	17
Commissioning.....	45
connecting hose between the SR-unit and the junction box.....	39, 42
Connecting pressure, temperature and purge air monitor .....	40
Connecting the purge air supply.....	31
Connection diagram for variant 3G.....	36
Connection diagram of connection unit for variant 3G / Ex zone 2.....	36
Contrast.....	57
<b>E</b>	
enclosure.....	97
Environmentally compatible disposal .....	87
Explosion protection .....	20
<b>F</b>	
Feeding protective gas.....	51
FS850S parameters.....	97
Function buttons.....	57
<b>G</b>	
Gas pressure in gas duct too high.....	78
<b>H</b>	
Hinge pin.....	52
horizontal and vertical adjustment.....	50
<b>I</b>	
installation steps.....	26
Install flanges with tube.....	26
Install the adjustment device.....	49
Install the reflector unit on the intermediate flange.....	52
interfaces.....	35
Internal drifts correction .....	17
<b>L</b>	
light source.....	49
Lines.....	35
<b>M</b>	
Maintenance plan .....	66
Menu tree.....	58
<b>N</b>	
Nominal pressure in enclosure.....	97
<b>O</b>	
of the centering disc.....	48
Optical fine alignment .....	52
Overpressure monitoring failure.....	77
<b>P</b>	
Potential equalization on the purge air fixture.....	40
Power connection in connection unit.....	44

Preparing the power supply..... 43  
 Prepurging..... 97  
 pressurized enclosure..... 51  
 Product identification..... 15  
 protective gas connection..... 50  
 Pull the installation plate..... 53  
 Purge air unit..... 20, 31

**R**

Removing the measuring system..... 87  
 requirements for commissioning..... 45  
**requirements for decommissioning**..... 85

**S**

Safety information ..... 45  
 Screw the grounding conductor..... 40, 44  
 Setting the display contrast..... 58  
 spare parts..... 66  
 start-up steps..... 46  
 Storage..... 23  
 System safety..... 46

**T**

Transport safety device..... 23  
 Troubleshooting..... 75

**V**

Visual inspection..... 76

**Z**

zero and reference values ..... 18  
 Zero point..... 17

**Australia**

Phone +61 3 9457 0600  
1800 334 802 - tollfree  
E-Mail sales@sick.com.au

**Austria**

Phone +43 22 36 62 28 8-0  
E-Mail office@sick.at

**Belgium/Luxembourg**

Phone +32 2 466 55 66  
E-Mail info@sick.be

**Brazil**

Phone +55 11 3215-4900  
E-Mail marketing@sick.com.br

**Canada**

Phone +1 905 771 14 44  
E-Mail information@sick.com

**Czech Republic**

Phone +420 2 57 91 18 50  
E-Mail sick@sick.cz

**Chile**

Phone +56 2 2274 7430  
E-Mail info@schadler.com

**China**

Phone +86 20 2882 3600  
E-Mail info.china@sick.net.cn

**Denmark**

Phone +45 45 82 64 00  
E-Mail sick@sick.dk

**Finland**

Phone +358-9-2515 800  
E-Mail sick@sick.fi

**France**

Phone +33 1 64 62 35 00  
E-Mail info@sick.fr

**Germany**

Phone +49 211 5301-301  
E-Mail info@sick.de

**Hong Kong**

Phone +852 2153 6300  
E-Mail ghk@sick.com.hk

**Hungary**

Phone +36 1 371 2680  
E-Mail office@sick.hu

**India**

Phone +91 22 6119 8900  
E-Mail info@sick-india.com

**Israel**

Phone +972 4 6881000  
E-Mail info@sick-sensors.com

**Italy**

Phone +39 02 274341  
E-Mail info@sick.it

**Japan**

Phone +81 3 5309 2112  
E-Mail support@sick.jp

**Malaysia**

Phone +6 03 8080 7425  
E-Mail enquiry.my@sick.com

**Mexico**

Phone +52 (472) 748 9451  
E-Mail mario.garcia@sick.com

**Netherlands**

Phone +31 30 2044 000  
E-Mail info@sick.nl

**New Zealand**

Phone +64 9 415 0459  
0800 222 278 - tollfree  
E-Mail sales@sick.co.nz

**Norway**

Phone +47 67 81 50 00  
E-Mail sick@sick.no

**Poland**

Phone +48 22 539 41 00  
E-Mail info@sick.pl

**Romania**

Phone +40 356 171 120  
E-Mail office@sick.ro

**Russia**

Phone +7 495 775 05 30  
E-Mail info@sick.ru

**Singapore**

Phone +65 6744 3732  
E-Mail sales.gsg@sick.com

**Slovakia**

Phone +421 482 901201  
E-Mail mail@sick-sk.sk

**Slovenia**

Phone +386 591 788 49  
E-Mail office@sick.si

**South Africa**

Phone +27 11 472 3733  
E-Mail info@sickautomation.co.za

**South Korea**

Phone +82 2 786 6321  
E-Mail info@sickkorea.net

**Spain**

Phone +34 93 480 31 00  
E-Mail info@sick.es

**Sweden**

Phone +46 10 110 10 00  
E-Mail info@sick.se

**Switzerland**

Phone +41 41 619 29 39  
E-Mail contact@sick.ch

**Taiwan**

Phone +886 2 2375-6288  
E-Mail sales@sick.com.tw

**Thailand**

Phone +66 2645 0009  
E-Mail Ronnie.Lim@sick.com

**Turkey**

Phone +90 216 528 50 00  
E-Mail info@sick.com.tr

**United Arab Emirates**

Phone +971 4 88 65 878  
E-Mail info@sick.ae

**United Kingdom**

Phone +44 1727 831121  
E-Mail info@sick.co.uk

**USA**

Phone +1 800 325 7425  
E-Mail info@sick.com

**Vietnam**

Phone +84 945452999  
E-Mail Ngo.Duy.Linh@sick.com

Further locations at [www.sick.com](http://www.sick.com)

