

MLG-2 ProNet

Measuring automation light grid with
PROFIBUS fieldbus



Described product

MLG-2 ProNet

Manufacturer

SICK AG
Erwin-Sick-Str. 1
79183 Waldkirch
Germany

Legal information

This work is protected by copyright. Any rights derived from the copyright shall be reserved for SICK AG. Reproduction of this document or parts of this document is only permissible within the limits of the legal determination of Copyright Law. Any modification, abridgment or translation of this document is prohibited without the express written permission of SICK AG.

The trademarks stated in this document are the property of their respective owner.

© SICK AG. All rights reserved.

Original document

This document is an original document of SICK AG.

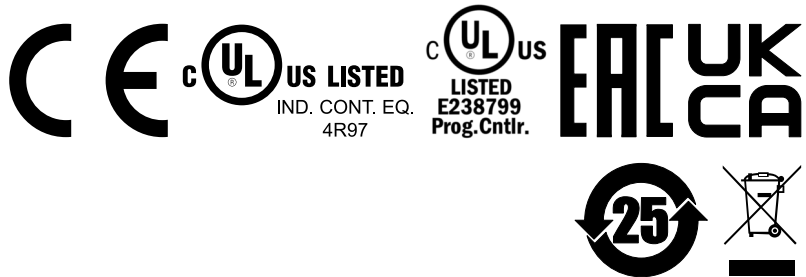

Contents

1	About this document.....	7
1.1	Further information.....	7
1.2	Symbols used.....	7
1.3	Abbreviations used.....	7
2	Safety information.....	9
2.1	Requirements for the qualification of personnel.....	9
2.2	Correct use.....	9
2.3	General safety notes.....	10
3	Product description.....	11
3.1	Type code.....	11
3.1.1	Monitoring height.....	12
3.1.2	Optical properties.....	12
3.1.3	Preconfigurations.....	12
3.2	MLG-2 product properties.....	13
3.3	Setup and function.....	13
3.3.1	MLG-2 ProNet device components.....	13
3.3.2	Measurement principle.....	14
3.3.3	Beam separations and monitoring height.....	15
3.3.4	Sensing ranges.....	16
3.3.5	Synchronizing the MLG-2.....	16
3.3.6	Teach-in.....	16
3.3.7	Beam blanking.....	17
3.4	Scan time.....	17
3.4.1	Response time, minimum presence time and reproducibility of the MLG-2.....	18
3.4.2	Scan time with cross-beam function.....	18
3.4.3	Scan time with high-speed scan on the MLG-2.....	19
3.5	Beam separation and minimum detectable object.....	20
3.5.1	Minimum detectable object with parallel-beam function.....	20
3.5.2	Minimum detectable object length.....	21
3.5.3	Minimum detectable object with cross-beam function	22
3.5.4	Minimum detectable object with high measurement accuracy from the MLG-2.....	23
3.6	Operating reserve.....	24
3.6.1	Operating reserves on the MLG-2.....	24
3.7	MLG-2 operating modes.....	24
3.7.1	Standard operating mode.....	24
3.7.2	Transparent operating mode.....	24
3.7.3	Dust- and sunlight-resistant operating mode.....	25
3.8	Interfaces, functions and process data.....	25
3.8.1	Interfaces.....	26
3.8.2	Configurable functions.....	26

3.8.3	Available process data.....	29
3.9	Display and operating elements.....	31
3.9.1	Sender.....	31
3.9.2	Receiver.....	31
3.9.3	Fieldbus module.....	33
3.10	Application examples.....	33
3.10.1	Application examples for the MLG2.....	33
4	Mounting.....	35
4.1	Scope of delivery.....	35
4.2	Recommended mounting arrangements.....	35
4.2.1	Mounting with light in opposite directions.....	35
4.2.2	Mounting with light in the same direction.....	36
4.2.3	Placement of two light grids at right angles.....	38
4.2.4	Minimum distance from reflective surfaces.....	39
4.3	Mounting procedure.....	40
4.3.1	Mounting the QuickFix bracket.....	40
4.3.2	Mounting the FlexFix bracket.....	42
4.3.3	Turning the fieldbus module on the MLG-2.....	44
4.3.4	Mounting the fieldbus module offset from the MLG-2.....	46
5	Electrical installation.....	47
5.1	Fieldbus module connections.....	48
5.2	Sender connections.....	50
5.3	MLG-2 ProNet connection.....	51
6	Commissioning.....	54
6.1	Mechanical alignment of sender and receiver.....	54
6.2	Alignment and teach-in.....	55
7	The MLG-2 on the PROFIBUS network.....	57
7.1	Overview.....	57
7.1.1	Addressing.....	58
7.1.2	GSD file.....	60
7.2	Manufacturer-specific object library.....	60
7.3	Cyclic data (process data).....	63
7.3.1	Modules with beam functions.....	64
7.3.2	Modules with system information.....	73
7.3.3	Modules for initiating operating functions.....	74
7.3.4	Compatibility objects for the preceding version.....	74
7.4	Acyclic data (service data).....	77
7.4.1	Parameters for the teach-in function.....	77
7.4.2	Parameters for definition of operating mode and performance options.....	81
7.4.3	Parameters with auxiliary resources and diagnostic options.....	85
7.4.4	Parameters with system information.....	89

7.4.5	Beam evaluation.....	90
8	Configuration with SOPAS ET.....	93
8.1	Preparation.....	93
8.1.1	Installing the software.....	93
8.1.2	Device selection.....	93
8.2	SOPAS ET interface.....	94
8.2.1	System boundaries and status.....	95
8.2.2	Basic functions and status of the output.....	96
8.2.3	Representation of the detection area.....	97
8.2.4	Expandable menus.....	101
8.3	System settings.....	103
8.3.1	System settings for the user levels EASY and EXPERT.....	103
8.3.2	System settings for the EXPERT user level.....	103
8.3.3	System settings for PROFIBUS.....	105
8.4	Measuring and diagnostic functions for switching outputs.....	105
8.4.1	Height classification.....	106
8.4.2	Object recognition.....	108
8.4.3	Object detection/object width.....	110
8.4.4	Hole detection/hole size.....	112
8.4.5	Outside/inside dimension.....	114
8.4.6	Classification of an object position.....	116
8.4.7	Classification of a hole position.....	117
8.4.8	Diagnostics.....	119
8.4.9	Advanced settings for the outputs.....	119
8.5	Zones.....	120
8.5.1	“Zone measuring” function.....	120
8.6	Teach-in.....	123
8.7	Performance options.....	125
8.7.1	“Cross beam” function.....	128
8.7.2	Energy option (only at the EXPERT user level).....	131
8.8	Beam evaluation.....	131
8.8.1	“Blocked Beams Hold (BBH)” evaluation mode.....	131
8.8.2	“Lost Beams Hold (LBH)” evaluation mode.....	132
8.9	Simulation.....	133
8.10	Beam monitor (only in the EXPERT user level).....	135
8.11	Function programming (in the EXPERT user level).....	136
8.11.1	Beam functions.....	138
9	Configuration of MLG-2 with the internal web server.....	140
10	Servicing.....	141
11	Troubleshooting.....	142
11.1	Response to faults.....	142
11.2	SICK support.....	142

11.3	LED indicators and error indicators.....	142
11.4	Advanced diagnostics on the MLG-2.....	143
12	Decommissioning.....	144
12.1	Disposal.....	144
12.2	Returns.....	144
13	Technical data.....	145
13.1	Data sheet.....	145
13.2	Fieldbus module data sheet.....	147
13.3	Diagrams.....	148
13.3.1	Response time and minimum presence time without high-speed scan.....	148
13.3.2	Response time and minimum presence time during high-speed scan with 2,5 mm resolution.....	149
13.3.3	Response time and minimum presence time during high-speed scan with up to 3.5 m sensing range.....	149
13.3.4	Response time and minimum presence time during high-speed scan with up to 8.5 m sensing range.....	150
13.3.5	Minimum detectable absorption.....	150
13.4	Dimensional drawings.....	151
13.4.1	Dimensional drawing MLG-2 ProNet.....	151
13.4.2	Measurement tables.....	152
13.4.3	Dimensional drawings for the MLG-2 fieldbus module.....	154
14	Ordering information.....	156
15	Accessories.....	157
15.1	Auxiliary equipment.....	157
15.2	Mounting materials.....	157
15.3	Connection materials.....	157
16	Annex.....	160
16.1	Conformities and certificates.....	160
16.2	Licenses.....	160
17	List of figures.....	161
18	List of tables.....	164

1 About this document

1.1 Further information

You can find the product page under the **Product ID**: pid.sick.com/{P/N}.

P/N corresponds to the part number of the product.

The following information is available depending on the product:

- Data sheets
- These operating instructions in all available languages
- CAD files and dimensional drawings
- Certificates (e.g., declaration of conformity)
- Other publications
- Software
- Accessories

1.2 Symbols used

Recommendation

Recommendations are designed to assist you in the decision-making process with respect to the use of a certain function or a technical measure.



NOTE

Notes inform you about special aspects of the device.



LED symbols describe the status of a diagnostics LED. Examples:

	The LED is illuminated continuously.
	The LED flashes evenly.
	The LED flashes briefly.
	The LED is off.

► Take action ...

Instructions for taking action are indicated by an arrow. Carefully read and follow the instructions for action.



CAUTION Warning!

A warning indicates a specific or potential hazard. This is intended to protect you against accidents.

Read carefully and follow the warnings!

Sender and receiver

In figures and connection diagrams, the symbol indicates the sender and indicates the receiver.

1.3 Abbreviations used

BNB	Beam Number Blocked
BNM	Beam Number Made
CBB	Central Beam Blocked
CBM	Central Beam Made
FBB	First Beam Blocked
FBM	First Beam Made

GSD	Device data sheet
IDI	Inside Dimension
LBB	Last Beam Blocked
LBM	Last Beam Made
MDA	Minimum Detectable Absorption
MDO	Minimum Detectable Object
MLG-2	Measuring automation light grid 2
MOL	Minimum Detectable Object Length
MSB	Most Significant Bit
NBB	Number of Beams Blocked
NBM	Number of Beams Made
NCBB	Number of Consecutive Beams Blocked
NCBM	Number of Consecutive Beams Made
ODI	Outside Dimension
RLC	Run-length code
SDD	SOPAS Device Description
PLC	Programmable logic controller

2 Safety information

2.1 Requirements for the qualification of personnel

The MLG-2 measuring automation light grid must only be mounted, commissioned, and maintained by authorized personnel.



NOTE

Repair work on the MLG-2 may only be performed by qualified and authorized service personnel from SICK AG.

The following qualifications are necessary for the various tasks:

Table 1: Authorized personnel

Task	Qualification
Mounting	<ul style="list-style-type: none"> • Basic practical technical training • Knowledge of the current safety regulations in the work-place
Electrical installation and device replacement	<ul style="list-style-type: none"> • Practical electrical training • Knowledge of current electrical safety regulations • Knowledge of the operation and control of the devices in their particular application (e. g., industrial robots, storage and conveyor systems)
Commissioning, operation, and configuration	<ul style="list-style-type: none"> • Knowledge of the current safety regulations and of the operation and control of the devices in their particular application • Knowledge of automation systems • Knowledge of how to use automation software

2.2 Correct use

The MLG-2 measuring automation light grid is a measuring device which is manufactured according to the recognized industrial regulations and which meets the quality requirements stipulated in ISO 9001:2008 as well as those relating to environmental management systems as defined in ISO 14001:2009.

The measuring automation light grids are solely intended for the optical and non-contact detection of objects, animals, and persons.

A measuring automation light grid is designed for mounting and may only be operated according to its intended function. For this reason, it is not equipped with direct safety devices.

The system designer must provide measures to ensure the safety of persons and systems in accordance with the legal guidelines.

In the event of any other usage or modification to the MLG-2 measuring automation light grid (e.g., due to opening the housing during mounting and electrical installation) or in the event of changes made to the SICK software, any claims against SICK AG under the warranty will be rendered void.

Foreseeable misuse

The MLG-2 is **not** suitable for the following applications, among others:

- As a safety device to protect persons, their hands, or other body parts
- Under water
- In explosive environments
- Outdoors, without additional protection

2.3 General safety notes



CAUTION

Observe the following to ensure the safe use of the MLG-2 as intended.

The measuring automation light grid must be installed and maintained by trained, qualified personnel with knowledge of electronics, precision engineering, and control programming. The relevant technical safety standards must be observed.

All persons entrusted with the installation, operation, or maintenance of the devices must follow the safety guidelines:

- The operating instructions must always be available and must be followed.
 - Unqualified personnel must stay away from the system during installation and maintenance.
 - The system must be installed in accordance with the applicable safety regulations and mounting instructions.
 - The work safety regulations of the employers' liability insurance associations and trade associations in the respective country must be observed during installation.
 - Failure to observe the relevant work safety regulations may lead to physical injury or cause damage to the system.
-

3 Product description

3.1 Type code

Example

MLG-2 with 5 mm beam separation, ProNet type, detection height 145 mm, 1 input, 1 digital output, as well as 2 analog outputs, no options, 5 m sensing range.

Table 2: Example of an MLG-2 ProNet type code

1	2	3	4	5	6	7	8	9	10	11	12	13	14	15	16	17
M	L	G	0	5	N	-	0	1	4	5	P	1	0	5	0	1

Table 3: Meaning of the positions in the type code

Position	Meaning	
1 ... 3	Product family	MLG
4 and 5	Beam separation	02 = 2.5 mm 05 = 5 mm 10 = 10 mm 20 = 20 mm 25 = 25 mm 30 = 30 mm 50 = 50 mm
6	Type	0 = special type N = ProNet
7	Hyphen	-
8 ... 11	Detection height	0000 = special detection height see table 4, page 12
12	Interfaces, I/O	P = PROFIBUS
13	Options	1 = none
14 and 15	Optical properties	see table 5, page 12
16 and 17	Preconfiguration of the I/O connections and software	01: Standard (DPV1) 02: For replacement (DPV0)

3.1.1 Monitoring height

Table 4: Monitoring height [mm]

	Type						
	MLG02...	MLG05...	MLG10...	MLG20...	MLG25...	MLG30...	MLG50...
Monitoring height [mm]	145	145	140	140	-	-	-
	295	295	290	280	275	270	250
	445	445	440	440	425	420	400
	595	595	590	580	575	570	550
	745	745	740	740	725	720	700
	895	895	890	880	875	870	850
	1045	1045	1040	1040	1025	1020	1000
	1195	1195	1190	1180	1175	1170	1150
	-	1345	1340	1340	1325	1320	1300
	-	1495	1490	1480	1475	1470	1450
	-	1645	1640	1640	1625	1620	1600
	-	1795	1790	1780	1775	1770	1750
	-	1945	1940	1940	1925	1920	1900
	-	2095	2090	2080	2075	2070	2050
	-	2245	2240	2240	2225	2220	2200
	-	2395	2390	2380	2375	2370	2350
	-	2545	2540	2540	2525	2520	2500
	-	-	2690	2680	2675	2670	2650
	-	-	2840	2840	2825	2820	2800
-	-	2990	2980	2975	2970	2950	
-	-	3140	3140	3125	3120	3100	

3.1.2 Optical properties

Table 5: Sensing range and minimum detectable object length

Position 14 and 15	Sensing range	Minimum detectable object length
00	Special	Special
32	2 m	2.5 mm
05	5 m	5 mm
08	8.5 m	5 mm

3.1.3 Preconfigurations

Table 6: Preconfiguration of MLG-2 ProNet with fieldbus version P

Position 16, 17	Output	Address
01	System status Status of digital output NBB LBB FBB ODI IDI	126 SSA

Position 16, 17	Output	Address
02	Set via Profibus master	SSA

3.2 MLG-2 product properties

- Different beam separations from 2.5 mm to 50 mm
- Monitoring heights from 130 to 3,140 mm
- Operating range up to 2 m, 5 m or 8.5 m
- Quick response time
- Convenient configuration using the SOPAS ET software interface
- Detection of transparent objects
- Dust- and sunlight-resistant
- Integrated applications including object detection, height classification, etc.

3.3 Setup and function

The MLG-2 is an optical light grid. It comprises a sender and a receiver.

The sender consists of sender optics, several sender elements (LEDs), and actuation electronics. The receiver consists of receiver optics, several receiver elements (photodiodes) and evaluation electronics.

3.3.1 MLG-2 ProNet device components

The MLG-2 ProNet consists of:

- Sender = MLG-2 Pro
- Receiver = MLG-2 ProNet
- Fieldbus module



Figure 1: MLG-2 ProNet device components

- ① MLG-2 Pro sender
- ② MLG-2 ProNet receiver
- ③ Fieldbus module

The sender has a connection for the power supply and the synchronization.

The receiver has a connection for the fieldbus module.

The fieldbus module has a fieldbus interface, an Ethernet connection for configuring via PC/notebook, a connection for the power supply, and a connection for the receiver.

3.3.2 Measurement principle

Provided no object is located between the sender and receiver elements, the light beams from the sender elements will hit the receiver elements.

If an object is located between the sender and receiver elements, the light beams will be blocked, depending on the size of the object.

Detection area

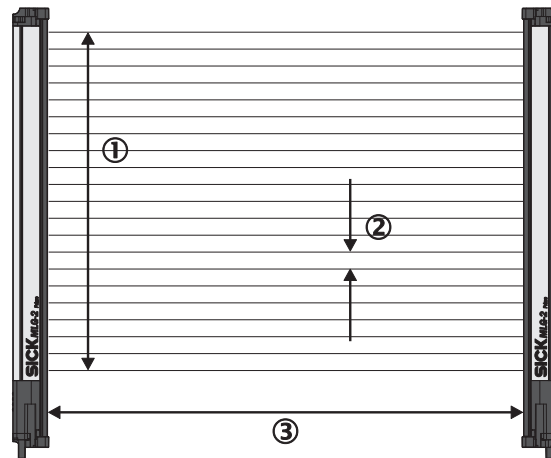

Figure 2: Detection area of the MLG-2

- ① Monitoring height
- ② Beam separation
- ③ Sensing range

The detection area is determined by the monitoring height and the sensing range of the light grid. The monitoring height is determined by the beam separation and the number of beams. The sensing range of the light grid is the distance between sender and receiver.

3.3.3 Beam separations and monitoring height

Beam separations

In order to achieve different levels of measurement accuracy, the MLG-2 is available with different beam separations.

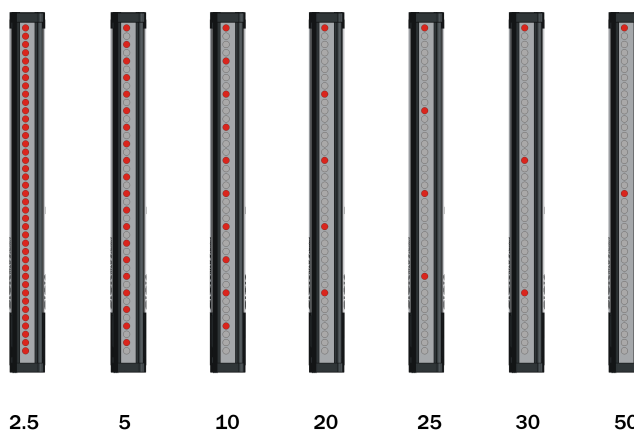

Figure 3: Schematic depiction of available beam separations (mm)

Maximum and minimum monitoring height

The number of LEDs is limited to 510. This results in different maximum monitoring heights depending on the beam separation. The minimum monitoring height is determined by the beam separation and the smallest module size for this beam separation.

Table 7: Maximum monitoring heights

Beam separation	Maximum monitoring height	Minimum monitoring height
2.5 mm	1195 mm	145 mm
5 mm	2,545 mm	145 mm
10 mm	3,140 mm	140 mm
20 mm	3,130 mm	130 mm
25 mm	3,125 mm	275 mm
30 mm	3,1320 mm	270 mm
50 mm	3,100 mm	250 mm

3.3.4 Sensing ranges

Operating range

Light grids are generally available with a 2 m range, 5 m range or 8.5 m sensing range. This is referred to as the operating range, which includes an operating reserve.

Limiting range

It is also possible to operate the MLG-2 up to its limiting range, which goes beyond the operating range.

Table 8: Limiting range

Operating range	Limiting range
2 m	2.8 m
5 m	7 m
8.5 m	12 m

Operation within the limiting range requires the following conditions:

- Clean ambient conditions
- Front screens are cleaned regularly
- Regular teach-in

The following functions cannot be provided when operating within the limiting range:

- High level of operating reserves
- High measurement accuracy
- Transparent operating mode
- Dust- and sunlight-resistant operating mode

3.3.5 Synchronizing the MLG-2

The sender and receiver synchronize with each other electronically, thus **one** electrical connection between the sender and receiver is necessary.

3.3.6 Teach-in

During the teach-in process, the switching thresholds for all beams are individually adjusted for the sensing range and the ambient conditions.

After teach-in has been completed, it must be ensured that the setup is no longer changed otherwise another teach-in will have to be carried out.

Teach-in quality

The teach-in quality indicates how successful the teach-in process has been. The MLG-2 calculates this value based on the quality of the light level received.

The value remains constant until another teach-in process is carried out.

Process quality

The process quality indicates the quality of the light level currently being received. The MLG-2 analyzes the light level received when the light path is unblocked and compares this to the values after the last teach-in process.

If the received values are getting worse, the process quality drops.

Possible causes of a drop in process quality include:

- Contamination or fogging of the front screen of the sender and/or receiver
- Misalignment
- Continuous partial blocking of a light beam or several light beams

3.3.7 Beam blanking

Individual beams can be blanked.

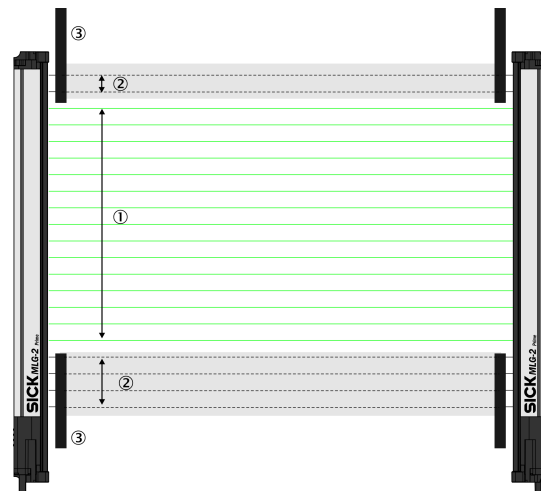

Figure 4: Detection area with beams blanked

- ① Included beams
- ② Blanked beams
- ③ Structural restrictions on the detection area

The MLG-2 offers a variety of options for masking beams.

3.4 Scan time

In the MLG-2, not all light beams are active at the same time, instead one light beam is activated after the other starting from the bottom.



Figure 5: Standard scan method

The scan time increases according to the number of beams of an MLG-2.

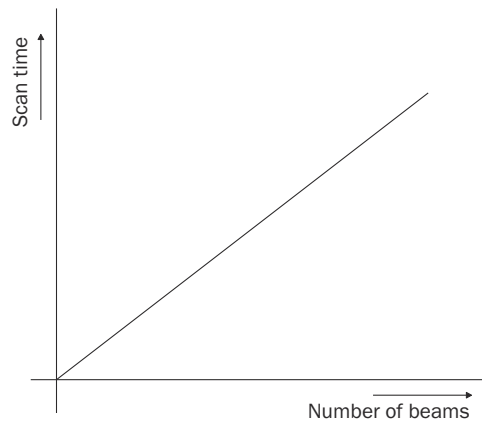

Figure 6: Scan time in relation to the number of beams

The scan time is used to determine the **response times** of the outputs, the **minimum presence time** of an object and the **repeat accuracy of a measurement result (reproducibility)**.

- The **response time** is the time it takes for an output to react following the detection of an object/gap. The maximum response time is $3 \times$ the scan time plus the transmission time to the outputs.
- The **minimum presence time** is the time an object or a gap has to be in the detection area for it to be detected. The minimum presence time is $\max. 2 \times$ the scan time.
- The repeat accuracy of a measurement result (**reproducibility**) is the amount of time by which an object detection can differ from a previous or subsequent detection. The reproducibility time is $1 \times$ the scan time.

3.4.1 Response time, minimum presence time and reproducibility of the MLG-2

On the MLG-2, the response time, minimum presence time, and reproducibility are displayed via SOPAS ET. Response time and minimum dwell time can be read off in the diagram see [figure 140, page 148](#).

3.4.2 Scan time with cross-beam function

When the cross-beam function is enabled, the light beam from a sender LED is received by three receiver diodes in two scans. This doubles the scan time.

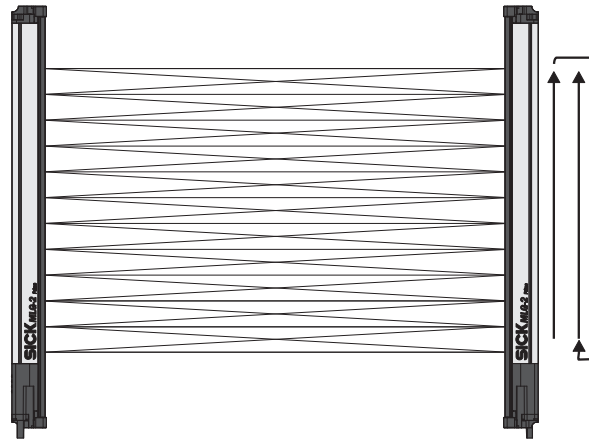

Figure 7: Cross-beam function

3.4.3 Scan time with high-speed scan on the MLG-2

With high-speed scan, several beams are active in each cycle. This reduces the scan time by a variable factor.

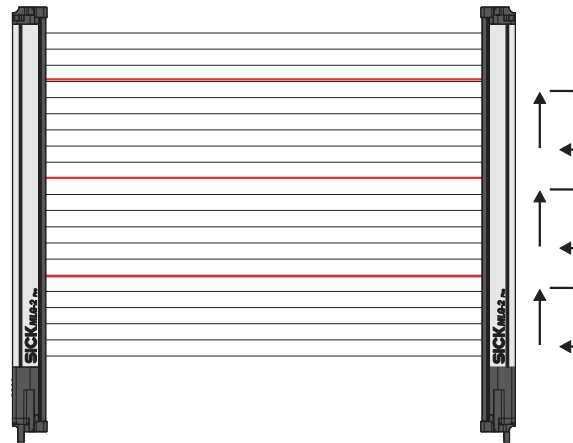

Figure 8: High-speed scan

The scan time is also dependent on the number of beams. Beyond a certain number of beams, the scan time is reduced because it is possible to use the high-speed scan.

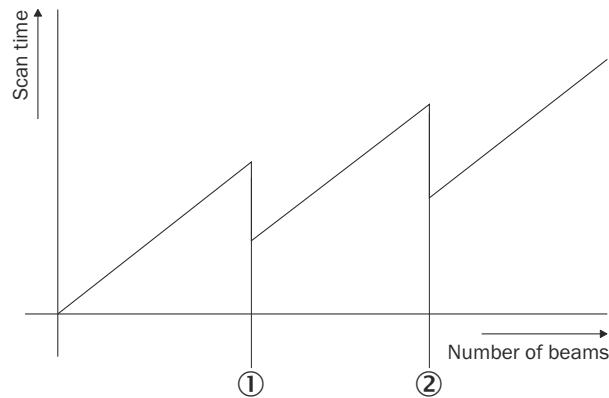

Figure 9: Scan time in relation to the number of beams when using the high-speed scan

- ① High-speed scan with 2 beams active simultaneously

② High-speed scan with 3 beams active simultaneously

The number of beams that can be activated at the same time depends on the size of the detection area (sensing range, beam separation, and number of beams). On the MLG-2, the response time, minimum presence time, and reproducibility are displayed via SOPAS ET. You can also find the response time and minimum presence time when using the high-speed scan in the diagrams in these operating instructions (see "Diagrams", page 148).



NOTE

With a beam separation of 2.5 mm, the high-speed scan can only be adjusted in combination with the high measurement accuracy function.

3.5 Beam separation and minimum detectable object

The measurement accuracy achieved by the MLG-2 depends on the beam separation.

3.5.1 Minimum detectable object with parallel-beam function

In order for an object to be detected continuously, it must completely cover at least one beam. This is referred to as the minimum detectable object, or MDO.

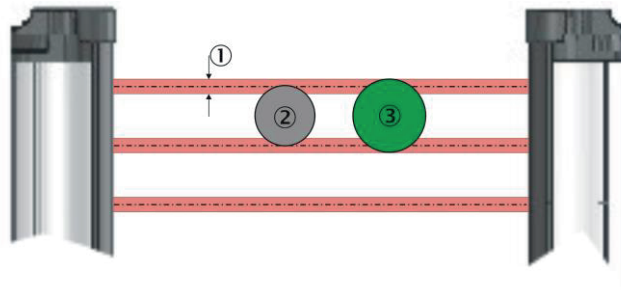

Figure 10: Minimum detectable object

- ① Beam diameter
- ② Object is not completely reliably detected
- ③ Object is reliably detected (meets requirements of minimum detectable object size)



NOTE

For moving objects, the minimum detectable object depends on the speed of the object.

Table 9: Minimum detectable object in relation to the beam separation of the MLG-2

Beam separation	Minimum detectable object (stationary object) ¹²
2.5 mm	3.5 mm
5 mm	9 mm
10 mm	14 mm
20 mm	24 mm
25 mm	29 mm
30 mm	34 mm

Beam separation	Minimum detectable object (stationary object) ¹²
50 mm	54 mm

- ¹ Only if the object also meets the minimum detectable object length requirements.
- ² All the values are typical values and can be found in the respective setting modes.



NOTE

The minimum detectable object size is also dependent on the other performance options, such as the configured response time and operating reserve. The precise minimum detectable object size is displayed in SOPAS ET on the MLG-2 (see "SOPAS ET interface", page 94).

3.5.2 Minimum detectable object length

When an object moves through the detection area, it must have a certain length.

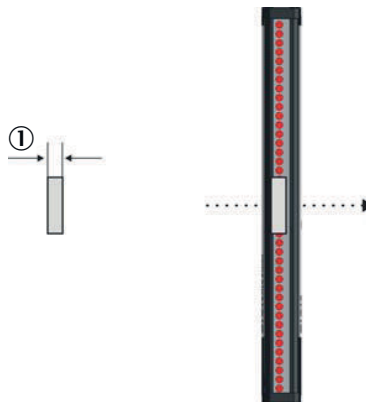

Figure 11: Minimum detectable object length

- ① Minimum detectable object



NOTE

For moving objects, the minimum detectable object length also depends on the speed of the object.

Table 10: Minimum detectable object length with the MLG-2

Beam separation	Minimum detectable object length (stationary object) ¹
2.5 mm	2.5 mm
5 ... 50 mm	5 mm

- ¹ Only if the object also meets the minimum detectable object requirements.



NOTE

The minimum detectable object length is also dependent on the other performance options, such as the configured response time and operating reserve. The precise minimum detectable object length is displayed in SOPAS ET on the MLG-2 (see "SOPAS ET interface", page 94).

3.5.3 Minimum detectable object with cross-beam function

The parallel-beam function is used for measuring by default. With the parallel-beam function, each light beam is received only by the receiver element situated directly opposite.

With the cross-beam function, a sender LED projects beams to several receiver diodes. The cross-beam function increases the measurement accuracy and enables the detection of smaller objects.

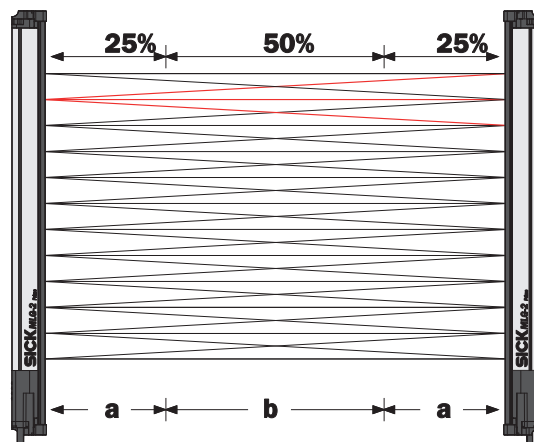

Figure 12: Cross-beam function

A minimum distance between the sender and the receiver is required for the cross-beam function. The minimum detectable object size depends on the position of the object within the detection area. Detection of the smaller minimum detectable object size is therefore only possible in the central area (b) of the detection area.

- The cross-beam function is only useful for object detection ($NBB \leq 1$). For other applications (height classification, object recognition, etc.), the results of the parallel-beam function are used.
- Use of the cross-beam function increases the response time.
- With the cross-beam function, a minimum distance needs to be maintained between sender and receiver. The minimum distance depends on the aperture angle of the light grid.
- For moving objects for the cross-beam function, the minimum detectable object depends on the speed of the object.

Table 11: Minimum detectable object with cross-beam function on the MLG-2

Beam separation	Minimum distance 2 m variant	Minimum distance 5 m variant	Minimum distance 8.5 m variant	Minimum detectable object (stationary object)	
				In area B	In area A
2.5 mm	200 mm	-	-	2.5 mm	4 mm
5 mm	-	110 mm	120 mm	6.5 mm	9 mm
10 mm	-	220 mm	240 mm	9 mm	14 mm
20 mm	-	440 mm	480 mm	14 mm	24 mm
25 mm	-	550 mm	600 mm	16.5 mm	29 mm
30 mm	-	660 mm	720 mm	19 mm	34 mm
50 mm	-	1110 mm	1200 mm	29 mm	54 mm

- High-speed scan is not possible.
- The minimum detectable object size with cross-beam function is also dependent on the other performance options, such as the configured response time and operating reserve. The precise minimum detectable object size is displayed in SOPAS ET on the MLG-2 (see "SOPAS ET interface", page 94).

3.5.4 Minimum detectable object with high measurement accuracy from the MLG-2

On the MLG-2, the measurement accuracy can be increased in SOPAS ET (see "Performance options", page 125). This means that an object can be detected even if it only covers half of a beam.

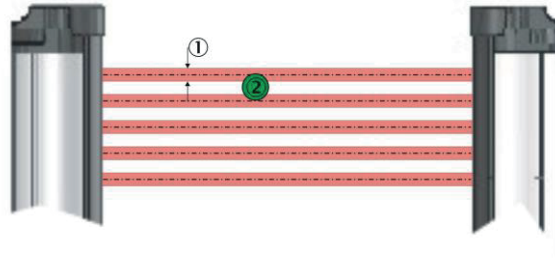

Figure 13: Minimum detectable object size with high measurement accuracy

- ① Beam diameter
- ② Object is reliably detected (meets requirements of minimum detectable object size)

Table 12: Minimum detectable object size with high measurement accuracy

Beam separation	Minimum detectable object (stationary object) ¹
2.5 mm	2.5 mm
5 mm	5 mm
10 mm	10 mm
20 mm	20 mm
25 mm	25 mm
30 mm	30 mm
50 mm	50 mm

¹ Only if the object also meets the minimum detectable length requirements (see table 10, page 21).

Minimum detectable object length

Table 13: Minimum detectable object length with high measurement accuracy

Beam separation	Minimum detectable object length (stationary object) ¹
2.5 mm	1 mm
5 ... 50 mm	2 mm

¹ Only if the object also meets the minimum detectable length requirements (see table 9, page 20).

- When using high measurement accuracy to detect moving objects, the minimum detectable object length also depends on the speed of the object and the other performance options, such as the configured response time and operating reserve. The precise minimum detectable object length is displayed in SOPAS ET on the MLG-2 (see "SOPAS ET interface", page 94).
- Sensing ranges larger than the operating range are not possible when using high measurement accuracy.
- High measurement accuracy can cause the operating reserve to decrease in the event of large sensing ranges and imperfect alignment.

3.6 Operating reserve

The operating reserve defines the operational safety before contamination, vibrations, misalignment, temperature fluctuations, etc. cause the MLG-2 to produce incorrect measurements.

The MLG-2 is subject to a certain level of contamination depending on its environment and application. In principle, the MLG-2 must be cleaned regularly and a teach-in should be carried out after cleaning.

3.6.1 Operating reserves on the MLG-2

On the MLG-2, the operating reserve can be adjusted according to the operating mode.

Standard operating reserve

The standard setting for the operating reserve is the best setting for most applications.

High level of operating reserves

Setting the operating reserve high makes the MLG-2 very resistant to contamination. However, it is not possible to activate high measurement accuracy in this case.



NOTE

In order to achieve a high operating reserve, the input sensitivity must be increased. This increases the risk of reflection. If there are reflective surfaces near the detection area, the light beams from the LEDs may reflect off these surfaces and reach the receiver, even though there is an object in the detection area.

The high input sensitivity means that only opaque objects can be detected. Transparent or semi-transparent objects are not detected.

Low operating reserve

Setting the measurement accuracy high reduces the operating reserve. When the operating reserve is low, the MLG-2 must be cleaned more frequently and a teach-in process must be carried out.

3.7 MLG-2 operating modes

The MLG-2 has the operating modes **Standard**, **Transparent** and **Dust and Sunlight-Resistant**.

Within the operating modes, the performance options can be used to modify the response time, minimum detectable object size, minimum detectable absorption (in Transparent operating mode), and operating reserve.

- The configurable performance options depend on the operating mode selected.
- When the operating mode is changed, a new teach-in process must be performed.

3.7.1 Standard operating mode

Standard operating mode is the mode in which most measuring applications can be carried out.

- Only opaque objects can be detected.
- There must not be a high level of constant light irradiation.

3.7.2 Transparent operating mode

Transparent operating mode enables the detection of transparent objects, such as those made of glass, PET, etc.

Transparent objects do not completely cover the light beam. In order to detect these objects, they must have what is known as a minimum detectable absorption (MDA).



NOTE

It is not possible to use the cross-beam function, high operating reserve or high-speed scan in the Transparent operating mode.

Minimum detectable absorption

In order to detect a transparent object, it must absorb a certain percentage of the energy from the light beam. Depending on the objects being measured, an object can be detected with 30% absorption, 15% absorption, or 10% absorption.



NOTE

The minimum detectable absorption that an object needs in order to be detected increases with the sensing range (see "[Minimum detectable absorption](#)", page 150).

Examples of the signal attenuation of transparent objects¹⁾:

- Approx. 10% signal attenuation:
Clean PET bottles, clear glass, thin and clear films (e.g., cellophane), household plastic film, plastic wrapping
- Approx. 15% signal attenuation:
Clean clear glass bottles, thick films, film and wrapping folded multiple times
- Approx. 30% signal attenuation:
Green and brown glass, colored glass bottles

The following prerequisites must be met:

- The sender and receiver must be aligned precisely with one another.
- The sender and receiver elements must be kept clean at all times.

AutoAdapt

The AutoAdapt function is active in the Transparent operating mode. AutoAdapt adjusts the switching threshold at which objects are detected in accordance with the level of contamination on the MLG-2. As a result, the MLG-2 thus becomes less sensitive as the level of contamination increases.

3.7.3 Dust- and sunlight-resistant operating mode

Dust and sunlight-resistant operating mode is intended for applications when there is a large amount of dust in the environment or a high level of solar radiation.

- Dust and sunlight-resistant operating mode reduces the maximum sensing range
 - To 1.2 m for devices with a 2 m operating range
 - To 3 m for devices with a 5 m operating range
 - To 5 m for devices with an 8.5 m operating range
- This operating mode can only be configured on an MLG-2 with fewer than 240 beams.

3.8 Interfaces, functions and process data

The MLG-2 has a number of different interfaces that can be used to output a measurement result or configure the MLG-2.

¹⁾ Examples are for illustrative purposes only. The signal attenuation and the minimum detectable absorption to be configured must be determined for each individual application.

3.8.1 Interfaces

- One interface for integration into a PROFIBUS fieldbus (see "The MLG-2 on the PROFIBUS network", page 57)
- One Ethernet interface for configuration with SOPAS ET (see "Configuration of MLG-2 with the internal web server", page 140) or with the integrated web server (see "Configuration with SOPAS ET", page 93).
- One switching output (push-pull)
The functions of this switching output can be configured in SOPAS ET (see "Measuring and diagnostic functions for switching outputs", page 105). These functions can also be configured using PROFIBUS.

3.8.2 Configurable functions

The MLG-2's functions can be configured using SOPAS ET, the integrated web server, or via the respective fieldbus. The tables below show which application is used to configure each function.

Table 14: Functions available for or during teach-in

Name	Function	Available for		
		SOPAS ET	Web server	Fieldbus
Teach-in	Starts a teach-in	■	■	■
Teach-in result	Result of the teach-in	■	■	■
Teach-in required	Teach-in required for further operation	■	-	■
Teach-in with blanking	Activate beam blanking for each teach-in	■	-	■
Auto teach-in	Starts a teach-in every time when switching on	■	-	-
Blanks blocked beams	Excludes all blanking beams during the teach-in	■	■	■
Blanks beams made	Excludes all beams made during the teach-in	■	■	■
Beam mask	Any defined beams will be excluded from the measurement. In SOPAS ET by clicking the mouse In the fieldbus via a bit-coded beam mask	■	-	■



NOTE

The information in the MLG-1 operating instructions (8014134) available at www.sick.com applies for the FBM-P22 fieldbus module.

Table 15: Functions available for operating modes and performance options

Name	Description	Available for		
		SOPAS ET	Web server	Fieldbus
Operating mode	Selection of the operating mode	■	■	■
Performance options	Defines the performance options	■	■	■
Minimum detectable absorption	Sets the minimum detectable absorption for Transparent operating mode	■	■	■

Name	Description	Available for		
		SOPAS ET	Web server	Fieldbus
Energy saving mode	Puts the MLG-2 on standby	■	-	■
Scanning method	Defines the parallel beam function, cross beam function or high-speed scan.	■ ¹⁾	-	■ ¹⁾
Configuration Q1	Function programming for switching output Q1	■	■	■
Alarm Q1	Defines various diagnostic settings for Q1	■	-	-
I/O configuration	Defines the function of Q1	■	-	-
Switch-off delay Q1, Q2, Q3 or Q4	Delays the corresponding output	■	-	■
Switch-off delay Q5 through Q16	Delays outputs Q5 through Q16	■	-	■

¹⁾ Available via the performance options.

Table 16: Configurable measuring and diagnostic functions for switching output Q1

Name	Available for		
	SOPAS ET	Web server	Fieldbus
Function programming for switching output Q1	■	■	■
Alarm Q1 Defines various diagnostic settings for Q1	■	-	-
I/O configuration Defines the function of Q1	■	-	-
Height classification	■	-	■
Object recognition	■	-	■
Object detection/object width	■	-	■
Hole detection/hole size	■	-	■
Outside/inside dimension	■	-	■
Classification of the object position	■	-	■
Classification of the hole position	■	-	■
Height classification within a zone	■	-	■
Object detection/object width within a zone	■	-	■
Classification of the object position within a zone	■	-	■
Measuring within zones	■	-	■
Diagnostics (display of warnings/errors)	■	-	■

Table 17: Auxiliary resources and diagnostic options

Name	Description	Available for		
		SOPAS ET	Web server	Fieldbus
Alignment aid	Activates the alignment aid	■	■	■

Name	Description	Available for		
		SOPAS ET	Web server	Fieldbus
Values for alignment aid	Returns the values from three beams	■	-	■
“Find Me” function	Activates the “Find Me” function	■	-	■
Pushbutton lock	Activates/deactivates the pushbutton lock	■	-	■
Beam numbering	Reverses the beam numbering	■	-	■
Factory settings	Resets the MLG-2 to its factory settings	■	■	■
Cloning upload	The device parameter set is saved to the fieldbus module.	■	■	■
Cloning download	The device parameter set is loaded from the fieldbus module.	■	■	■
Cloning status	The cloning status shows the status of the stored parameters in the fieldbus module.	■	■	■

Table 18: System information

Name	Description	Available for		
		SOPAS ET	Web server	Fieldbus
Device name	“MLG-2 ProNet” device name	■	■	■
Manufacturer name	“SICK AG” manufacturer name	■	■	■
Part number	Part number for the MLG-2 ProNet	■	-	■
Serial number	MLG-2 ProNet serial number	■	■	■
Product text	Description of MLG-2 ProNet	■	■	■
Mounting location	Option to enter the mounting location	■	■	■
Device characteristics	Display of the device characteristics and system boundaries	■	■	■
Hardware revision	Status of the hardware	■	■	■
Firmware version	The version of firmware	■	■	■

Table 19: Beam evaluation

Name	Description	Available for		
		SOPAS ET	Web server	Fieldbus
Zone measuring	Combines beams into zones and assigns them to a beam function and an output	■	-	■
Cross beam measuring	Activates the “Cross beam measuring” function	■	-	■
Blocked Beams Hold	Evaluation mode for all selected beam functions	■	-	■
Lost Beams Hold	Evaluation mode for all process data	■	-	■

Table 20: Settings for the interfaces

Name	Description	Available for		
		SOPAS ET	Web server	Fieldbus
IP address	Defines the IP address for the configuration interface	■	-	-
MAC address	Displays the MAC address for the configuration interface	■	-	-
Subnet mask	Defines the subnet mask for the configuration interface	■	-	-
Gateway address	Defines the gateway address for the configuration interface	■	-	-
DHCP	Activates DHCP for the configuration interface	■	-	-

Table 21: Settings for SOPAS ET

Name	Description	Available for		
		SOPAS ET	Web server	Fieldbus
Rotate the MLG-2 display	Rotates the display of the MLG-2 on the SOPAS interface	■	-	-
User level	Sets the user level in SOPAS ET	■	-	-

3.8.3 Available process data

The MLG-2 provides a series of process data. The following table shows which process data is available for the individual applications.

Table 22: Available process data

Name	Function	Available for		
		SOPAS ET	Web server	Fieldbus
NBB	Number of beams blocked Total number of beams blocked (e.g., for object detection)	■	■	■
NBM	Number of beams made Total number of beams made (e.g., for hole detection)	■	-	■
NCBB	Number of consecutive beams blocked (e.g., for object detection). If there are multiple objects in the detection area, the greatest number of consecutive beams blocked is displayed.	■	-	■
NCBM	Number of consecutive beams made (e.g., for hole detection). If there are multiple gaps in the detection area, the greatest number of consecutive beams made is displayed.	■	-	■
LBB	Last beam blocked Beam number of the last beam blocked (e.g., for object height measurement)	■	■	■
LBM	Last beam made Beam number of the last beam made	■	-	■

Name	Function	Available for		
		SOPAS ET	Web server	Fieldbus
FBB	First beam blocked Beam number of the first beam blocked (e.g., for height classification of a hanging object)	■	■	■
FBM	First beam made Beam number of the first beam made	■	■	■
ODI	Outside dimension Total number of beams between the first and last beams blocked (e.g., for measuring the outside dimension)	■	-	■
IDI	Inside dimension Total number of beams made between the first and last beams blocked (e.g., for measuring the inside dimension)	■	-	■
CBB	Central beam blocked Beam number of the central beam blocked (e.g., for measuring an object position)	■	-	■
CBM	Central beam made Beam number of the central beam made (e.g., for measuring a hole position)	■	-	■
NBB Zone X (X = 1, 2, 3 or 4)	Number of beams blocked in the indicated zone Total number of beams blocked (e.g., for object detection)	■	-	■
NCBB Zone X (X = 1, 2, 3 or 4)	Number of consecutive beams blocked (e.g., for object detection) in the indicated zone. If there are multiple objects in the detection area, the greatest number of consecutive beams blocked is displayed.	■	-	■
FBB Zone X (X = 1, 2, 3 or 4)	First beam blocked in the indicated zone Beam number of the first beam blocked (e.g., for height classification of a hanging object)	■	-	■
LBB Zone X (X = 1, 2, 3 or 4)	Last beam blocked in the indicated zone Beam number of the last beam blocked (e.g., for object height measurement)	■	-	■
CBB Zone X (X = 1, 2, 3 or 4)	Central beam blocked in the indicated zone Beam number of the central beam blocked (e.g., for measuring an object position)	■	-	■
RLC1 ... 16	Run-length code Outputs the value of the relevant change	■	■	■
Beam status	Beam status Outputs the value of each individual beam	■	-	■
QS	Status of the switching output	■	-	■
SYS	System status Consists of several status messages	■	■	■

Name	Function	Available for		
		SOPAS ET	Web server	Fieldbus
QoR	Process quality Shows the quality of the light level currently being received	■	■	■
QoT	Teach-in quality Shows the quality after the teach-in	■	-	■
Control	Used for control	-	-	■

3.9 Display and operating elements

3.9.1 Sender

The sender has three LEDs on its front. The LEDs are located on the connection side. The section [LED indicators and error indicators](#) on [page 142](#) explains the meaning of the LED indicators.

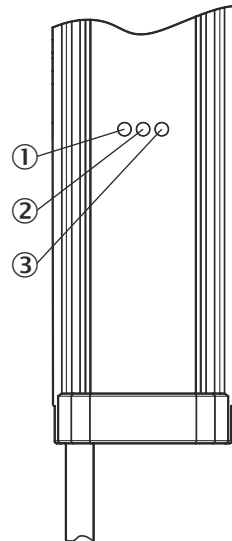

Figure 14: LEDs on the sender

- ① Yellow
- ② Red
- ③ Green

3.9.2 Receiver

The receiver has three LEDs on the front and a control panel with LED and membrane keys on the rear. The LEDs and the control panel are located on the connection side.

The section [LED indicators and error indicators](#) on [page 142](#) explains the meaning of the LED indicators.

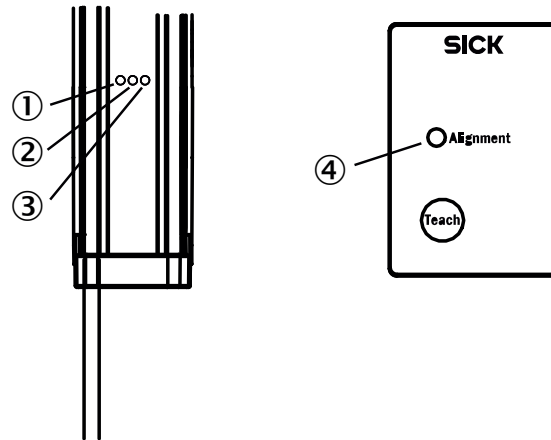

Figure 15: LEDs on the front and on the control panel

- ① Yellow
- ② Red
- ③ Green
- ④ Alignment LED

Control panel

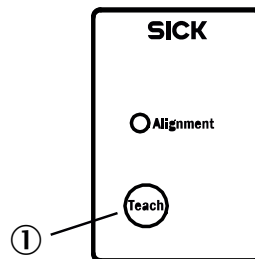

Figure 16: Control panel on the rear side

- ① Teach-in button

The teach-in process for the MLG-2 can be started by pressing the **Teach** pushbutton.

The button can be locked to prevent incorrect operation. The lock can be activated and deactivated via SOPAS ET, using the fieldbus functions, or by pressing the pushbutton.

Locking the control panel

- ▶ Press the **Teach** pushbutton for 15 s.
- ✓ The control panel is locked; the configuration cannot be changed.
- ✓ If a pushbutton is pressed on the control panel, the **Alignment LED** lights up briefly.

Disabling the lock

- ▶ Press the **Teach** pushbutton for 15 s.
- ✓ The lock is disabled again.

3.9.3 Fieldbus module

Status indicators

The fieldbus module has three LEDs.

The section [Troubleshooting](#) on [page 142](#) explains the meaning of the LED indicators.

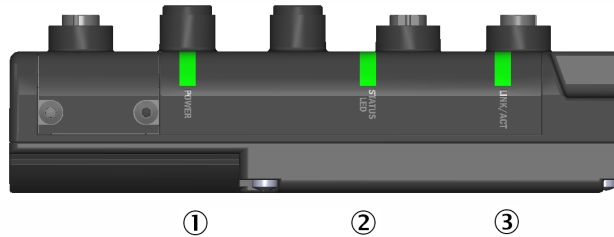

Figure 17: LEDs on the fieldbus module

- ① POWER
- ② STATUS
- ③ LINK/ACT

DIP switches

Eight DIP switches are located under a cover in the fieldbus module. With these switches, you can make settings for the respective fieldbus.



Figure 18: DIP switch on the fieldbus module

- ① DIP switches

3.10 Application examples

3.10.1 Application examples for the MLG2

The MLG-2 is suitable for complex applications including e. g. start and end detection, detection of small or transparent objects, traffic applications, volume measurement, or contour measurement.

Table 23: Application examples for the MLG-2

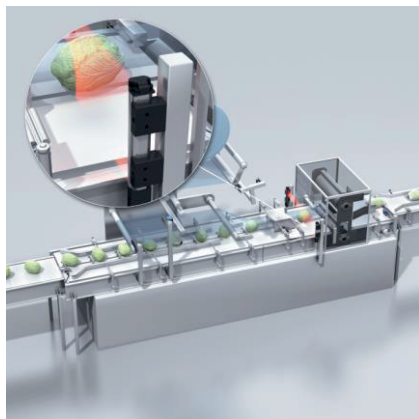

Figure 19: Start and end detection



Figure 20: Detection of transparent objects

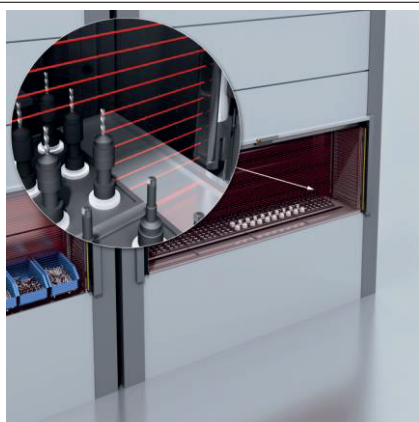

Figure 21: Detection of small objects

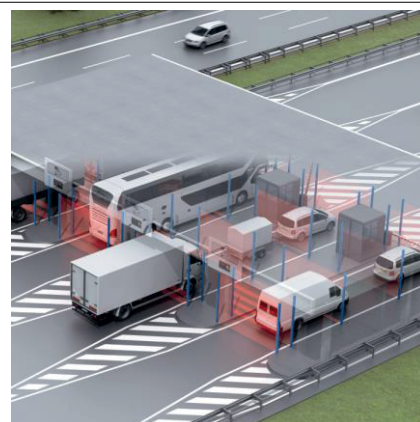

Figure 22: Traffic applications

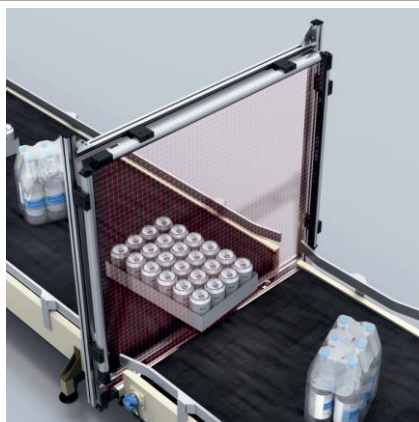

Figure 23: Volume measurement

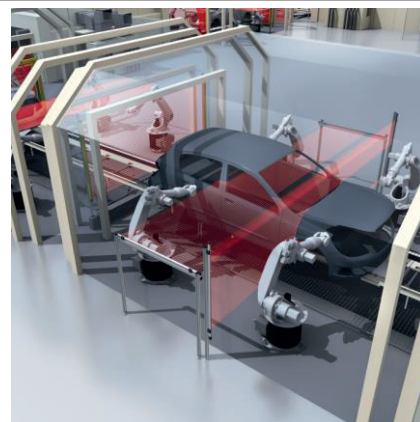

Figure 24: Contour measurement

4 Mounting

4.1 Scope of delivery

- 1 × sender
- 1 × receiver
- 4/6 x QuickFix brackets²⁾
- 1 x mounting bracket for the fieldbus module
- 1 × Quick Start Guide

4.2 Recommended mounting arrangements

When several MLG-2s are mounted close to one another, there is a risk of mutual interference. This is particularly likely if there are shiny surfaces nearby or if the objects being detected are shiny.

Therefore, when mounting two MLG-2s close to one another, their light beams should be oriented in opposite directions.

4.2.1 Mounting with light in opposite directions

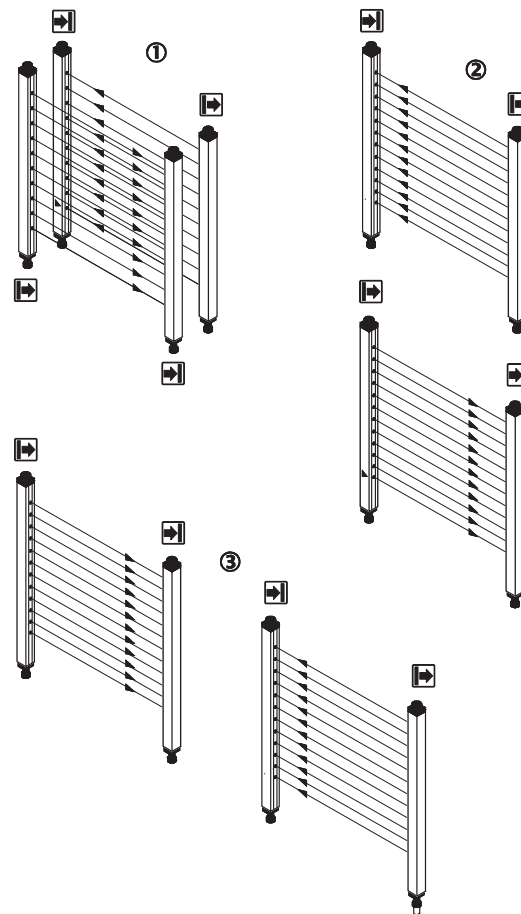

Figure 25: Placement with light in opposite directions

- ① Two MLG-2s, one behind the other
- ② Two MLG-2s, one above the other

²⁾ 6 x FlexFix brackets for monitoring heights above 2 m.

- ③ Two MLG-2s, one next to the other



NOTE

When two MLG-2s are placed opposite one another and their light beams are in opposite directions, ① reflections may occur from sender 1 to receiver 2 in the case of shiny objects.

4.2.2 Mounting with light in the same direction

When several MLG-2s are mounted with their light beams oriented in the same direction, a minimum distance must be maintained between the MLG-2s. The minimum distance increases as the distance between the sender and receiver increases and is dependent on the operating range.

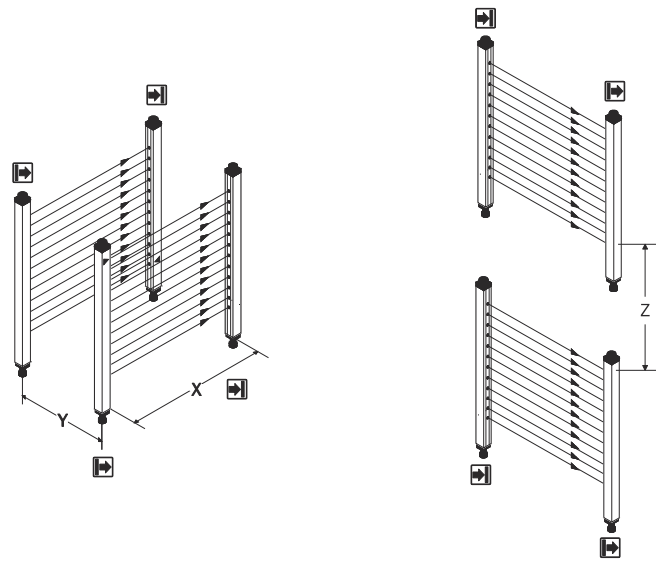

Figure 26: Distances when light is in the same direction

- X Operating range
- Y Minimum distance of the MLG-2
- Z Minimum distance of the MLG-2

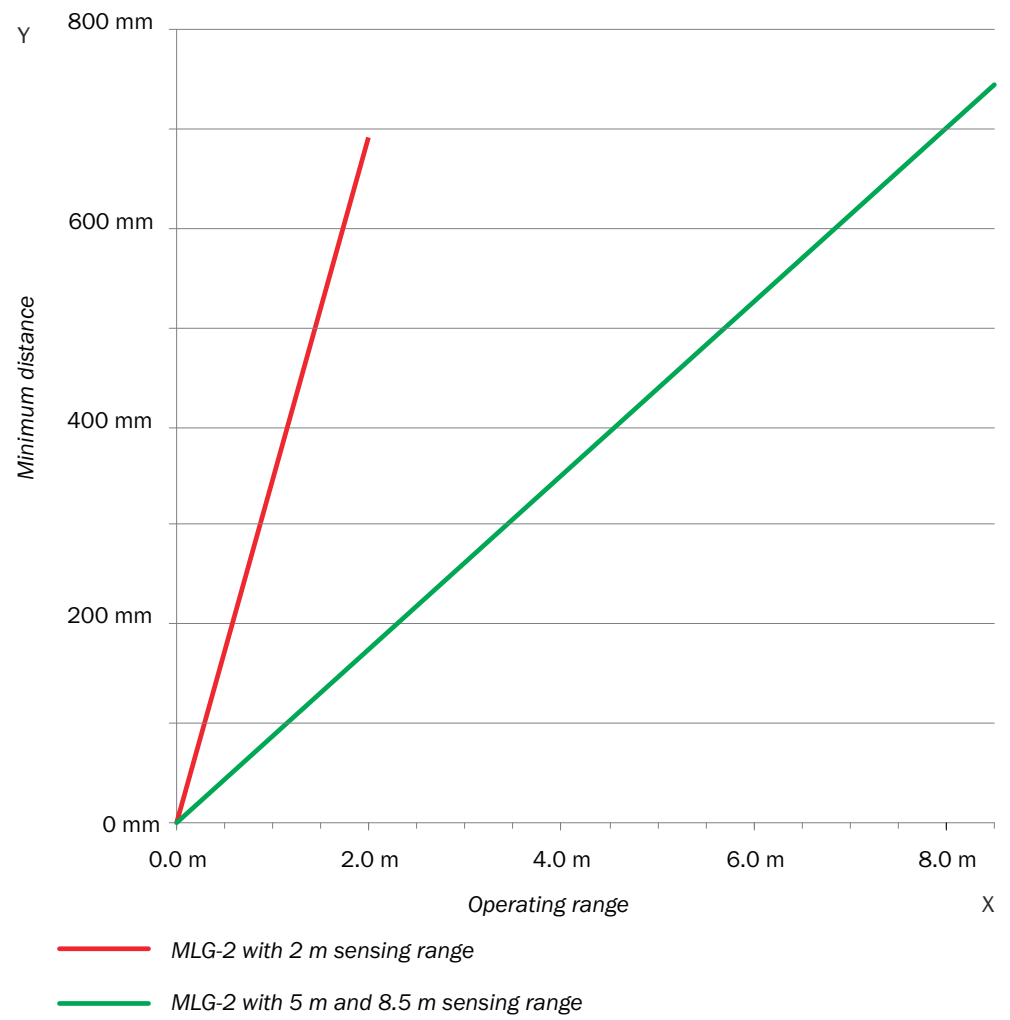

Figure 27: Graph, distances when light is in the same direction

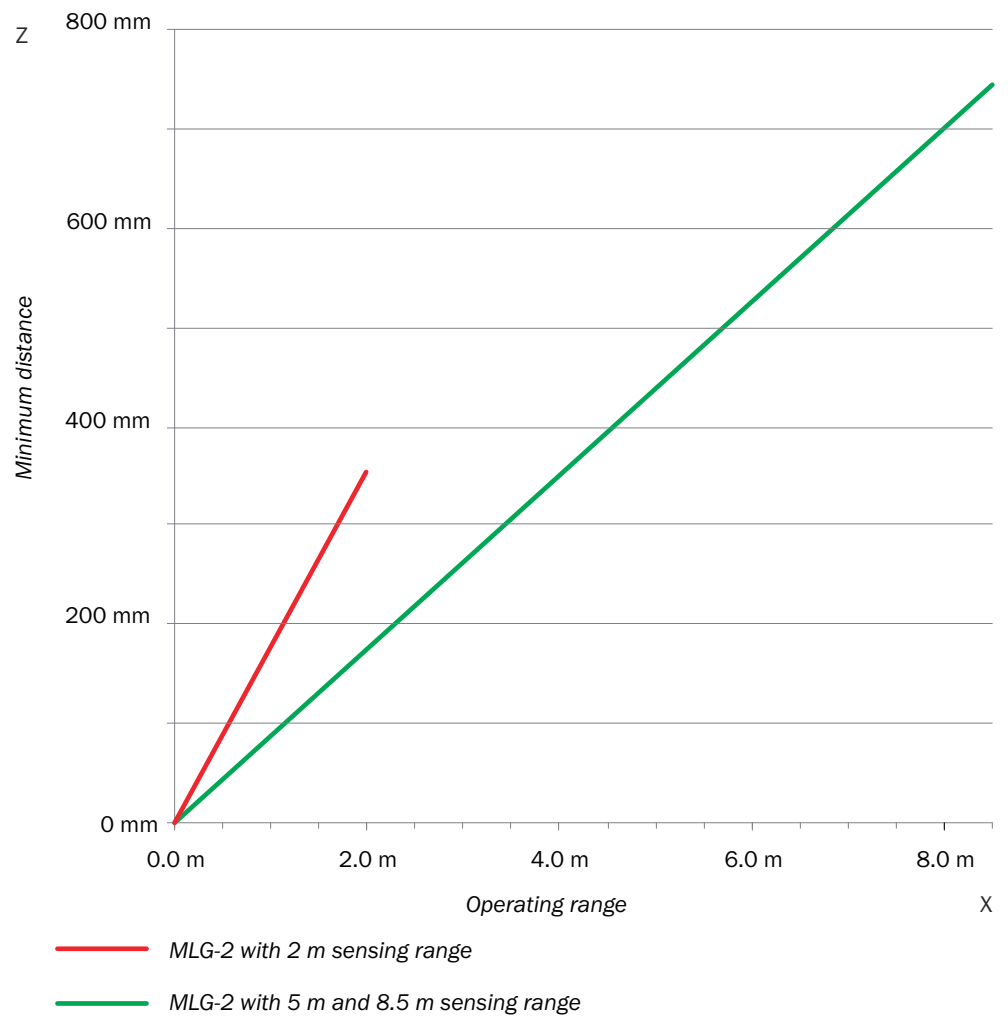

Figure 28: Graph, distances when light is in the same direction (XZ)

4.2.3 Placement of two light grids at right angles

Light grids are placed at right angles for volume detection or operator guidance, for example.

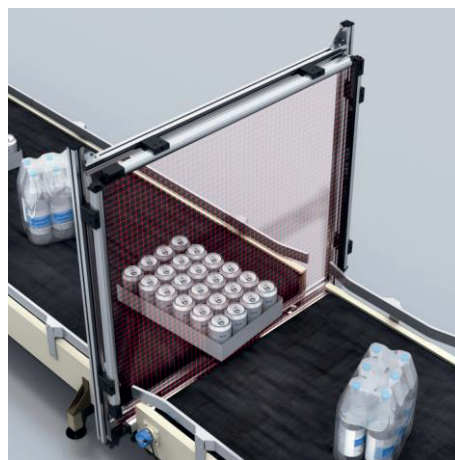

Figure 29: Placement of two light grids at right angles

Test inputs solution

Activate the test inputs of both senders alternately. The beams will be switched off in each case for as long as the test input is active.

Mounting solution

Mount the two MLG-2 as far apart as possible.

4.2.4 Minimum distance from reflective surfaces

Reflective surfaces between the sender and receiver may result in disruptive reflections and beams being deflected and, hence, result in a failure to detect objects.

In the case of reflective surfaces, a minimum distance must be maintained between the reflective surface and the light beams to ensure reliable operation.

This minimum distance depends on the distance between sender and receiver and on the operating range.

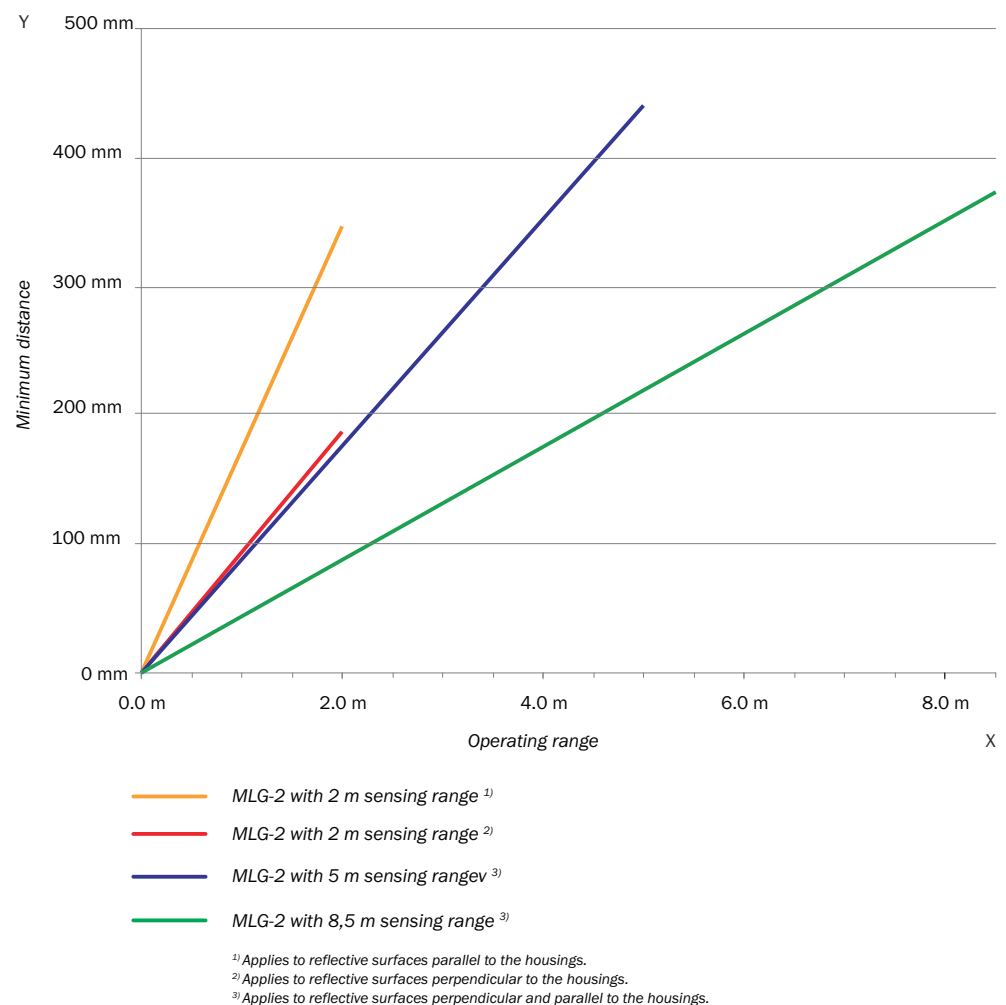

Figure 30: Graph, minimum distance from reflective surfaces

This distance also applies to reflective surfaces located next to the light grid (parallel to the sending/receiving axis).

4.3 Mounting procedure

- ▶ Mount the sender and receiver at the same height. For minor adjustments when aligning, the sender and receiver can be adjusted in the brackets.
- ▶ If possible, mount the top bracket at a height such that the offset in the housing of the MLG-2 sits on the bracket. This prevents the MLG-2 from sliding down.

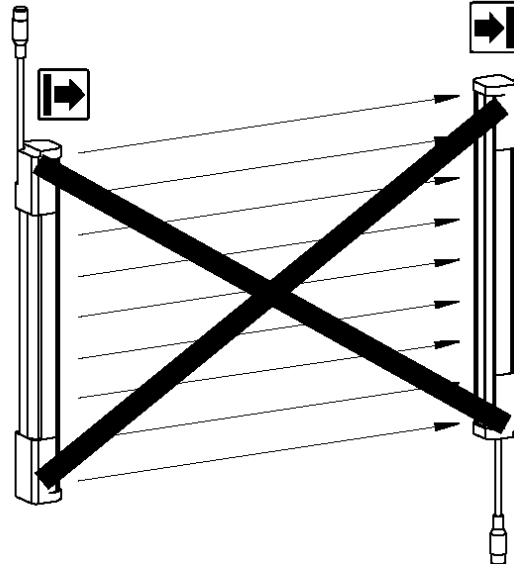

Figure 31: The sender and receiver are aligned incorrectly

The end with the cable connection must point in the same direction for both devices. Sender and receiver must **not be installed at 180° rotated relative to each other**.

Tighten the screws used to mount the bracket to a torque of 5 to 6 Nm. Tighten the screws used to secure the MLG-2 in the bracket to a torque of 2.5 to 3 Nm. Higher torques can damage the bracket while lower torques do not provide adequate fixation to prevent the MLG-2 from moving in the event of vibrations.

When mounting, make sure that sender and receiver are aligned correctly. The optical lens systems of sender and receiver must be located opposite one another. If necessary, use a water level to check the components are parallel.

4.3.1 Mounting the QuickFix bracket

QuickFix brackets can be mounted in two ways:

- On the side
- On the back

The two mounting surfaces for the brackets of the sender or receiver must not be angled more than $\pm 2^\circ$ to each other. If this is not possible, use the optional FlexFix bracket.

Mounting the QuickFix bracket on the side of a machine or profile frame

Up to a monitoring height of 2 m, the sender and receiver are mounted with two QuickFix brackets each.

For a monitoring height of more than 2 m, the sender and receiver are mounted with three QuickFix brackets each.

The QuickFix bracket consists of two parts, which are pushed into each other. An M5 screw is used to join both parts and to clamp the housing (sender or receiver).

Mounting can be carried out in two ways:

- With the M5 screw through the QuickFix bracket to the machine or profile frame. A screw nut or threaded hole is required on the machine or profile frame.
- With the M5 screw through the machine or profile frame to the QuickFix bracket. A screw nut is required for each QuickFix bracket.

When choosing the length of the M5 screw (hexagon head or cylinder head screw), consider the QuickFix bracket and the machine or profile frame.



CAUTION

Risk of injury from protruding screw thread!

When mounting through the machine or profile frame to the QuickFix bracket, the M5 screw can present an injury risk if too long.

- ▶ Select an appropriate screw length to prevent any risk of injury from an overrun.

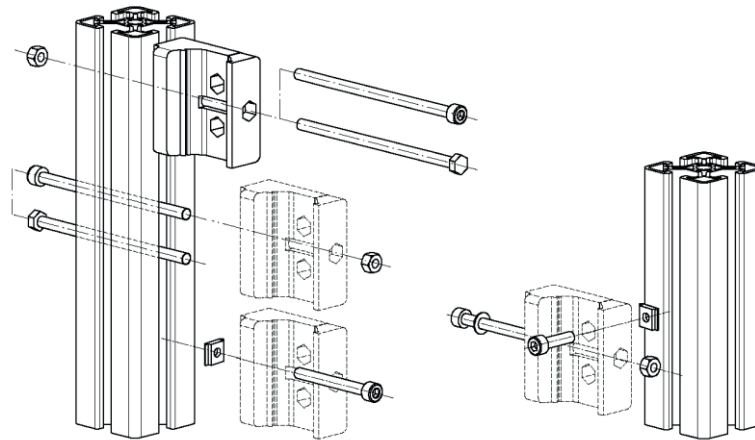

Figure 32: Mount QuickFix bracket to a profile frame

Mount QuickFix bracket to the back of a device column



NOTE

The QuickFix bracket has cable routing. Depending on the installation, the cable routing can make mounting easier.

The sender and receiver are each mounted with two QuickFix brackets.

The QuickFix bracket consists of two parts, which are pushed into each other. An M5 screw is used to join both parts and to clamp the housing (sender or receiver).

You need two M5 screws per bracket if mounting them on the back.

- ▶ Choose the length of the M5 screw such that it is possible to clamp the housing (sender or receiver) in the QuickFix bracket.

QuickFix bracket for the fieldbus module

If you are using the QuickFix bracket, you will need one more QuickFix bracket for the fieldbus module.

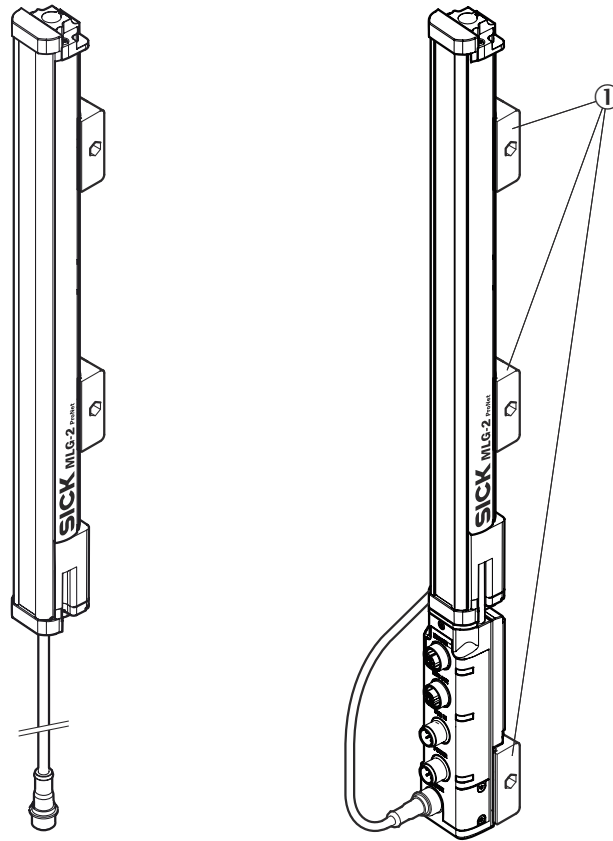

Figure 33: QuickFix bracket for the fieldbus module

① QuickFix brackets

4.3.2 Mounting the FlexFix bracket

In the FlexFix bracket, sender and receiver can be flexibly rotated by $\pm 15^\circ$.

FlexFix brackets can be mounted in two ways:

- On the side
- On the back

Mounting the FlexFix bracket on a profile frame

The sender and receiver are mounted at the designated points using two FlexFix brackets in each case.

M5 screws are inserted through the FlexFix bracket and into the machine or profile frame for mounting. A screw nut or threaded hole is required on the machine or profile frame.

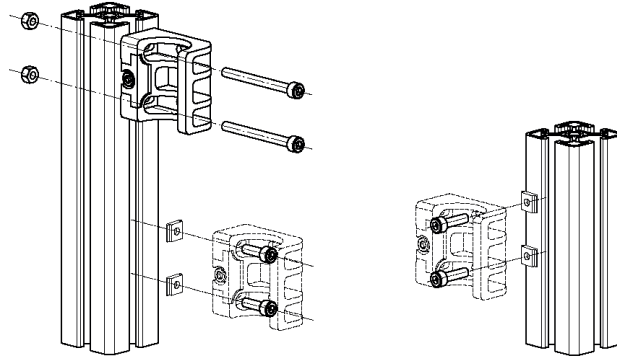

Figure 34: Mounting the FlexFix bracket on a profile frame

Screwing the sender or receiver into the FlexFix brackets

After mounting the FlexFix brackets, screw the sender or receiver into the FlexFix brackets from the front. Then align the sender and receiver.



NOTE

The MLG-2 can only be screwed in when both FlexFix brackets are in alignment. If necessary, use a water level to check the components are parallel.

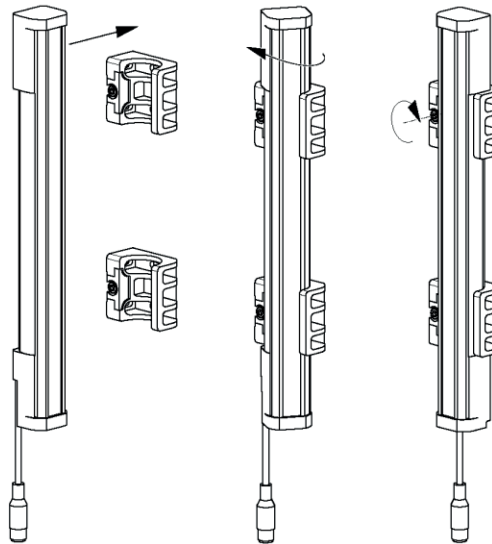

Figure 35: Inserting the MLG-2 in the FlexFix brackets

- Use an M5 screw to fix the position of the sender and receiver in the FlexFix bracket.

Mounting bracket for the fieldbus module

If you are using the FlexFix bracket, you will need a mounting bracket for the fieldbus module.

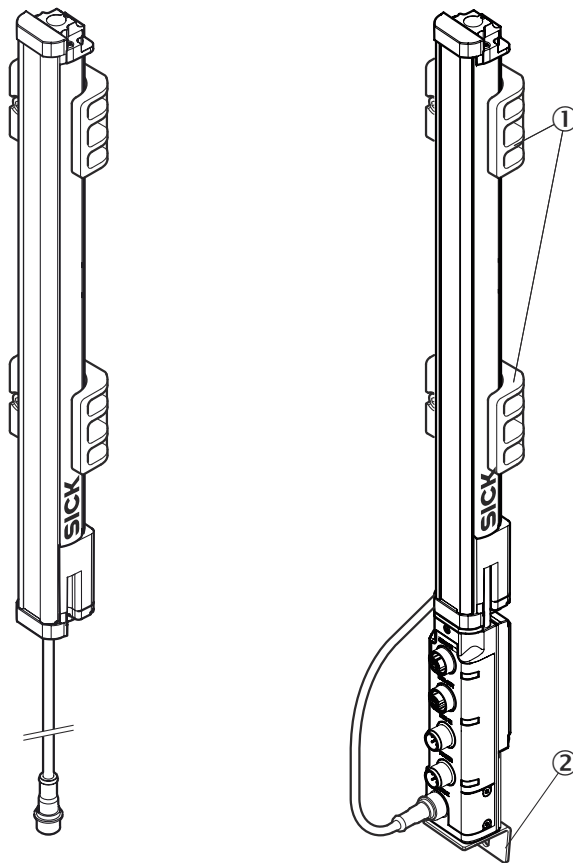

Figure 36: Mounting bracket for the fieldbus module

- ① FlexFix bracket
- ② Mounting bracket

1. Use the M5 x 6 screw provided to fasten the mounting bracket on the fieldbus module.
2. Use an M5 screw with a sliding nut, for example, to mount the mounting bracket on an industrial profile.

4.3.3 Turning the fieldbus module on the MLG-2

All connections of the fieldbus module are provided on one side. You can mount the fieldbus module rotated by 180° so you can feed the cables in from the front or the back.

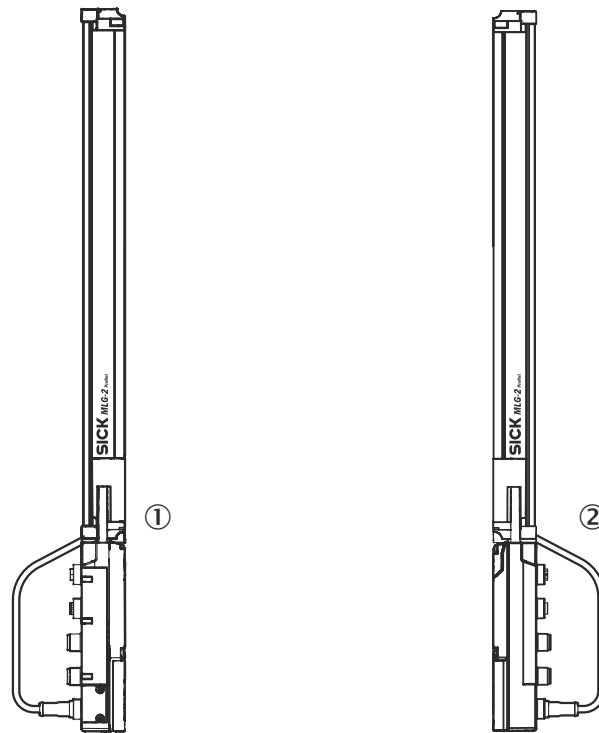

Figure 37: Mounting directions of the fieldbus module

- ① Mounting with the connections to the front side
- ② Mounting with the connections to the rear side

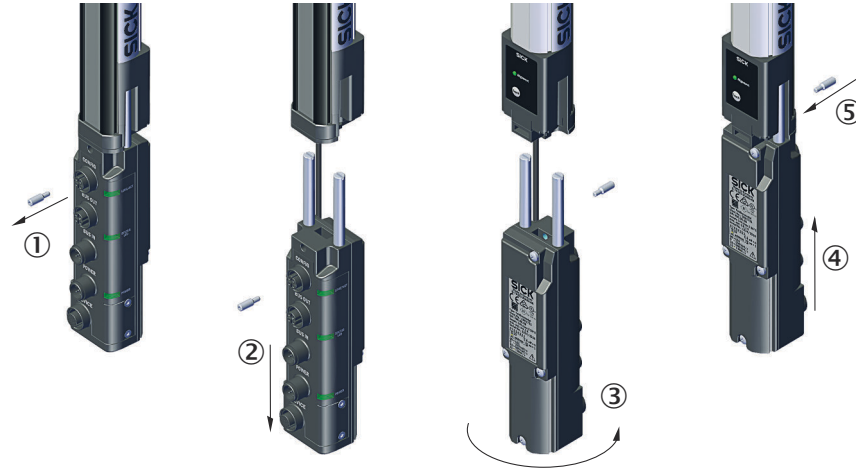

Figure 38: Turn the fieldbus module by 180°

- ① Unscrew the Torx T20 mounting screw
- ② Pull the fieldbus module downwards and away
- ③ Turn the fieldbus module by 180°
- ④ Insert the fieldbus module again
- ⑤ Tighten the mounting screw

4.3.4 Mounting the fieldbus module offset from the MLG-2

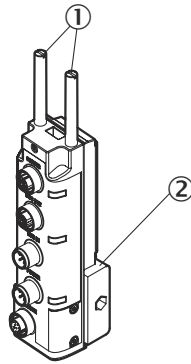

Figure 39: Mount the fieldbus module offset using the QuickFix bracket

- ① Mounting pins
- ② QuickFix bracket

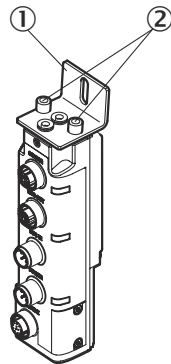

Figure 40: Mount the fieldbus module offset using the mounting bracket

- ① Mounting bracket
- ② M4 × 16

You can mount the fieldbus module offset.

- ▶ Remove the fieldbus module as described (see figure 38, page 45).
- ▶ Unscrew the mounting pins.
- ▶ Mount the fieldbus module using a QuickFix bracket.
- Or:
- ▶ Alternatively, mount the fieldbus module using a mounting bracket. Mount the mounting bracket on the fieldbus module using two M4 screws with a maximum length of 16 mm.
- ▶ Use an M5 screw with a sliding nut, for example, to mount the mounting bracket on an industrial profile.



NOTE

The maximum length of cable between the MLG-2 receiver and the FBM fieldbus module/AFB connection box must not exceed 2.7 m.

5 Electrical installation



CAUTION

De-energize the system!

The system could inadvertently start while you are connecting the devices.

- ▶ Make sure that the entire system is disconnected from the power supply during the electrical installation work.



NOTE

- The MLG-2 complies with the EMC regulations for the industrial sector (Radio Safety Class A). It may cause radio interference if used in a residential area.
- Do not lay cables parallel to other cables, especially not to devices with a high level of radiated emission, such as a frequency converter.
- When using cables over 15 m in length, or in locations with a high level of interference, we recommend using a T-distributor in order to connect the sender and receiver via a short synchronization cable wherever possible.



CAUTION

If you use the connecting cables with AWG 26 for the connection of the MLG-2, secure the MLG-2 with a 1 A / 30 V DC fuse. Use the following table for other wire cross-section fuses.

Table 24: Overcurrent protection

Wire cross-section		Maximum amperage for over-current protection
AWG	mm ²	
20	0.52	5
22	0.32	3
24	0.20	2
26	0.13	1
28	0.08	0.8
30	0.05	0.5

5.1 Fieldbus module connections

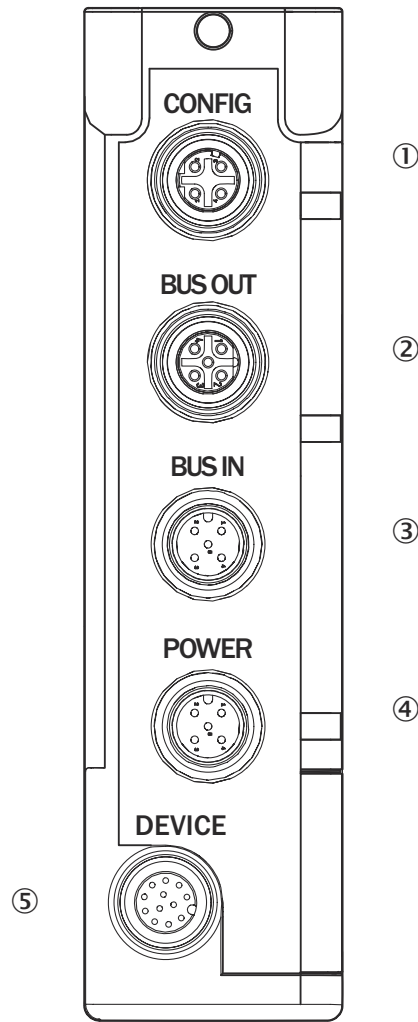

Figure 41: Fieldbus module connections

- ① CONFIG – Ethernet connection for configuring via PC/notebook
- ② BUS OUT - Serial connection of the fieldbus
- ③ BUS IN - Serial connection of the fieldbus
- ④ POWER – Power supply connection
- ⑤ DEVICE – Connection for the MLG-2 ProNet



NOTE

Protect all unused connections with a plastic cap!

CONFIG connection

Table 25: Pin assignment, MLG-2 fieldbus connection box, CONFIG

Female connector	Pin	Signal	Meaning
	1	TX+	Ethernet
	2	RX+	Ethernet
	3	TX-	Ethernet
	4	RX-	Ethernet

BUS OUT connection

Table 26: Pin assignment, MLG-2 fieldbus connection box, BUS OUT

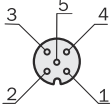
Female connector	Pin	Signal	Meaning
	1	+5 V	Bus voltage +5 V, e.g., electrically isolated for terminator
	2	PB_A	PROFIBUS A
	3	GND	Bus voltage 0 V, e.g., electrically isolated for terminator
	4	PB_B	PROFIBUS B
	5	Shield	Shield

BUS IN connection

Table 27: Pin assignment, MLG2 fieldbus connection box, BUS IN

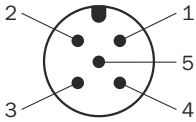
Male connector	Pin	Signal	Description
	1	Not connected	Not connected
	2	PB_A	PROFIBUS A
	3	Not connected	Not connected
	4	PB_B	PROFIBUS B
	5	Shield	Shield

POWER connection

Table 28: Pin assignment, MLG2 fieldbus connection box, POWER

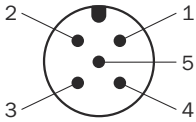
Male connector	Pin	Signal	Meaning	Color
	1	L+	24 V supply voltage	Brown
	2	Sync_A	Synchronization	White
	3	M	GND supply voltage	Blue
	4	Q1	Switching output	Black
	5	Sync_B	Synchronization	Gray

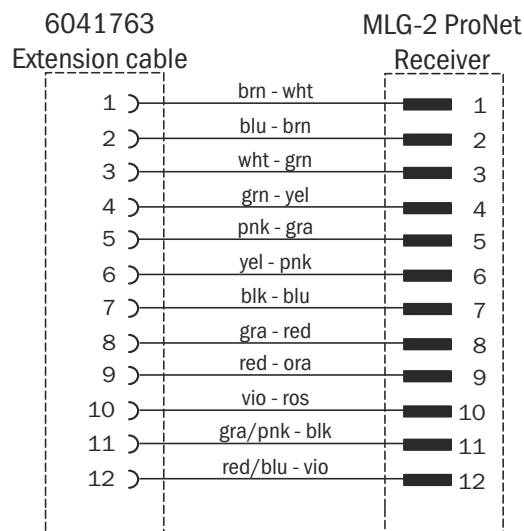
Device connection for the MLG-2 PRONET

5.2 Sender connections

In the case of the MLG-2, the sender and receiver synchronize with each other electronically. This means that **cabling is required** between the sender and fieldbus module.

You must connect the Sync_A signal on the sender to Sync_A on the fieldbus module, and Sync_B on the sender to Sync_B on the fieldbus module. You will find the Sync_A and Sync_D signals at the POWER connection of the fieldbus module.

Sender connection: M12/5-pin, A-coded

Table 29: Pin assignment, sender connection

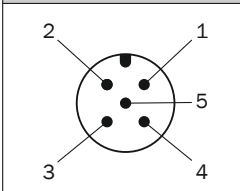
Male connector	Pin	Signal	Meaning	Color
	1	L+	24 V supply voltage	Brown
	2	Sync_A	Synchronization	White
	3	M	GND supply voltage	Blue
	4	Test_In	Test input	Black
	5	Sync_B	Synchronization	Gray

5.3 MLG-2 ProNet connection

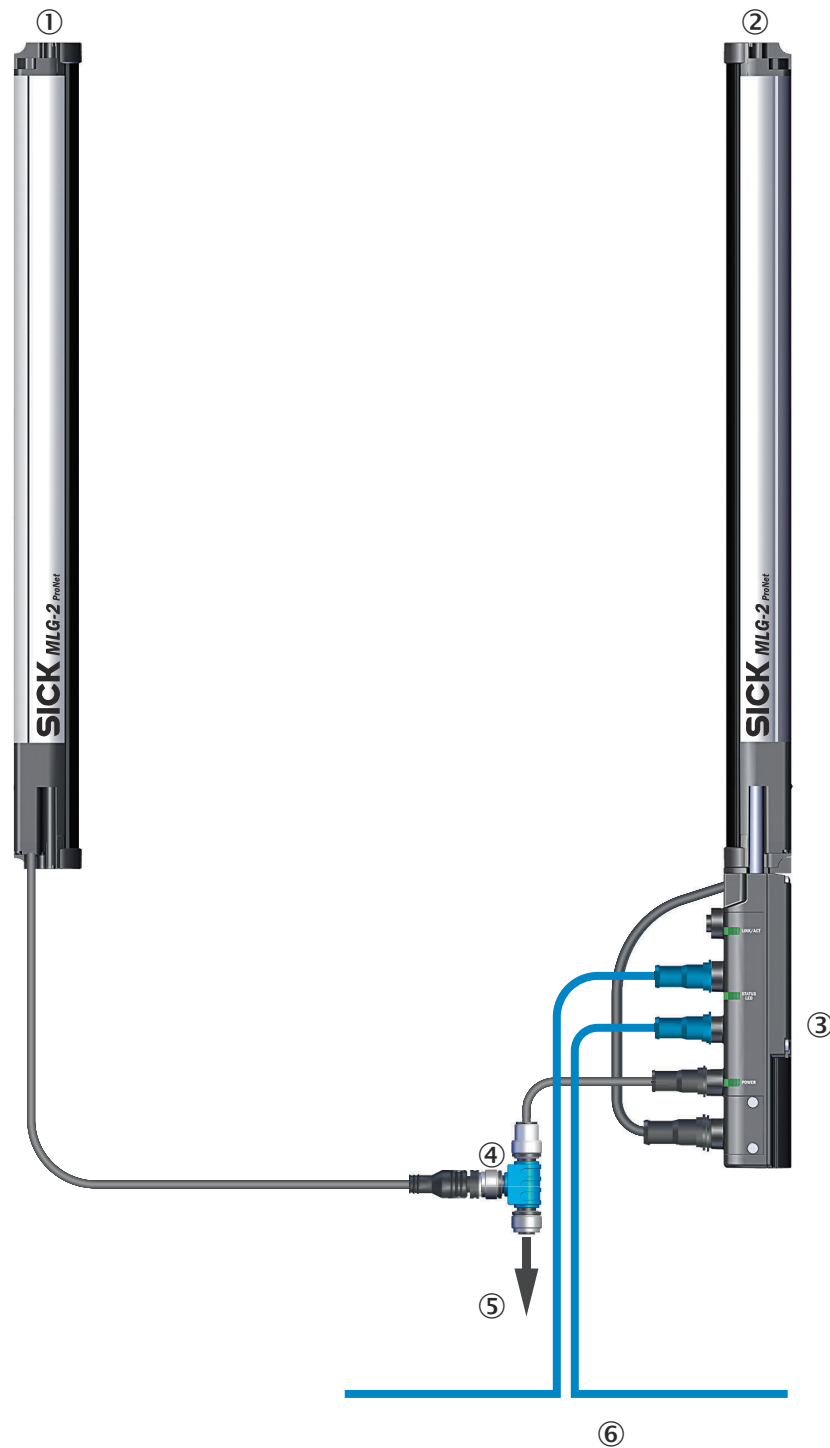

Figure 42: Connection to the PROFIBUS fieldbus

- ① Sender
- ② Receiver
- ③ Fieldbus module
- ④ T-distributor
- ⑤ Voltage supply
- ⑥ Fieldbus

Connection to the PROFIBUS fieldbus

PROFIBUS is an asynchronous serial fieldbus. As a rule, all subscribers are connected in a line (line topology). With its BUS IN and BUS OUT connections, the fieldbus module serves as a T-connector to the MLG-2. The MLG-2 is connected to the fieldbus with a stub cable. If replacement is necessary, the terminator (part number 6021156) must be supplemented (MLG-1 has an internal resistor).

The bus cables must satisfy the characteristics for cable type A according to IEC 61156:

- Two-wire, twisted and shielded
- Impedance: 135 ... 165 Ω at 3 ... 20 MHz
- Capacitance: < 30 pF/m
- Resistance: < 110 Ω /km
- Wire cross-section: > 0.34 mm²
- Wire diameter: > 0.64 mm



NOTE

- Do not mix up the two PROFIBUS A and PROFIBUS B High data cables in the same segment.
- Connect a large area of the shielding to protective ground at both ends of the cable.

We recommend using preassembled connection cables for the wiring (see "[Accessories](#)", page 157).

T-connector for connecting the sender and fieldbus module

A T-connector is available for the MLG-2 ProNet and can be used to connect the sender and fieldbus module to one another, and also to provide facilities for connecting the power supply, switching output 1, and the test input.

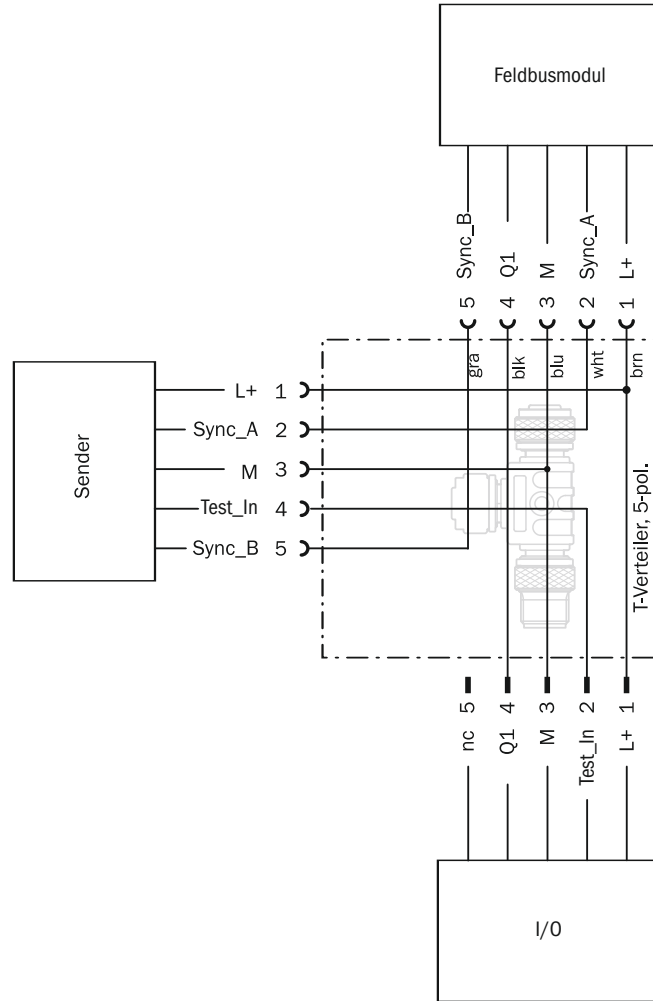

Figure 43: T-connector for sender and fieldbus module



NOTE

If replacement is necessary, please observe replacement document 8020350 (de) / 8020351 (en).

Table 30: Pin assignment, I/O connection of the T-connector

Male connector	Pin	Signal	Meaning
	1	L+	24 V supply voltage
	2	Test_In	Test input
	3	M	GND supply voltage
	4	Q1	Switching output 1
	5	Not connected	Not connected

6 Commissioning

6.1 Mechanical alignment of sender and receiver

After mounting and electrical installation, the sender and receiver must be aligned with each other. No objects should be located between the sender and the receiver. The light path must be clear.

Alignment with the QuickFix bracket

You have the following adjustment options with the QuickFix bracket:

- Adjust vertically (H)

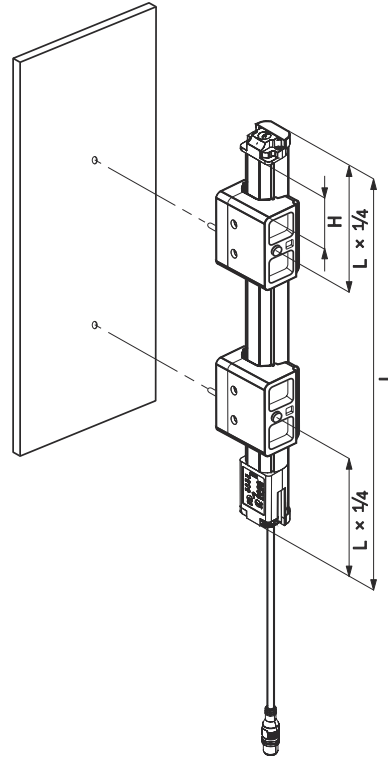

Figure 44: Alignment with the QuickFix bracket

Alignment with the FlexFix bracket

You have the following adjustment options with the FlexFix bracket:

- Adjust vertically (H)
- Rotate ($\pm 15^\circ$)

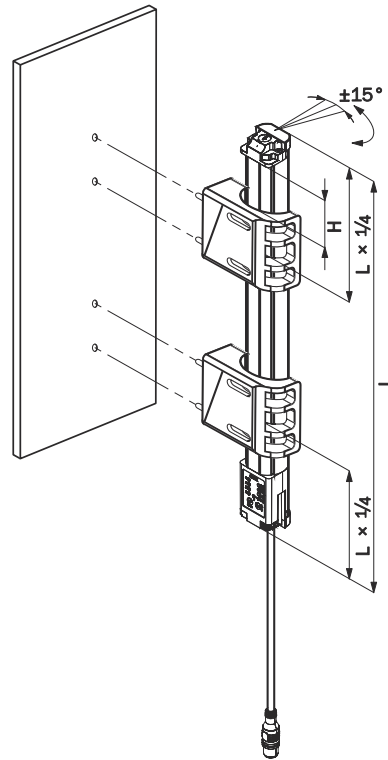

Figure 45: Alignment with the FlexFix bracket

6.2 Alignment and teach-in

To ensure the alignment aid works perfectly, the device should be rotated once from the left bracket stop to the right stop. This makes the best possible settings for the input sensitivity and ensures that the alignment aid shows the most helpful values.

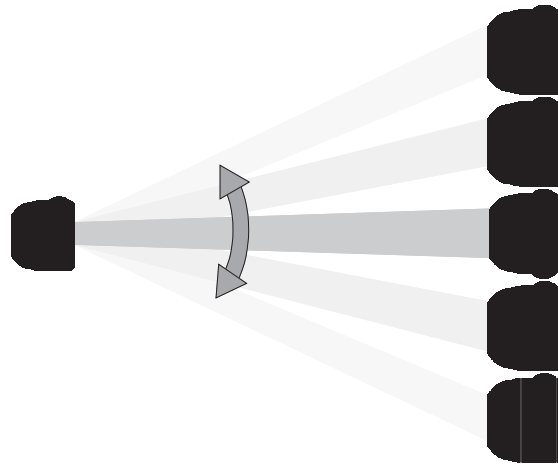

Figure 46: Rotate the receiver once

The yellow LED on the front of the receiver and the **Alignment LED** show the rough alignment.

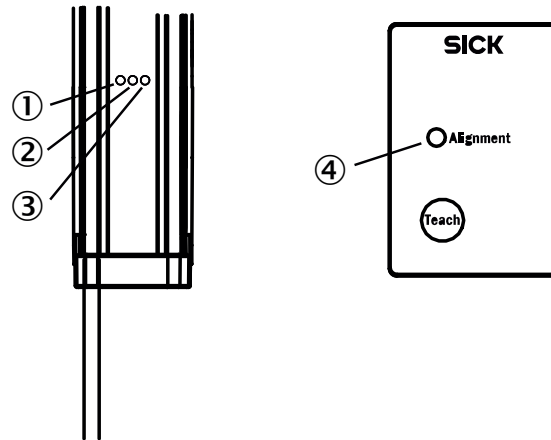

Figure 47: Control panel

- ① Yellow
- ② Red
- ③ Green
- ④ Alignment LED

☉ 3 Hz yellow

The yellow LED on the front and the **Alignment** LED on the control panel flash quickly.

- ▶ Improve the alignment of the MLG-2.
- ✓ When the yellow LED and the **Alignment** LED go out, the MLG-2 is optimally aligned.
- ▶ Now fix the position of the sender and receiver.³⁾

Teach-in

- ▶ Press the **Teach** pushbutton (< 1 s).⁴⁾
- ✓ **☉ 1 Hz yellow**
- ✓ The yellow LED on the front and the **Alignment** LED flash slowly.

If the teach-in process is successful, the yellow LED on the front and the **Alignment** LED go out. The MLG-2 is operational.

If the teach-in process is unsuccessful, the **Alignment** LED flashes rapidly, as does the red LED on the front of the device.

- ▶ Check that the MLG-2 is correctly aligned, that the front screens are clean, and that there are no objects located in the light path.
- ▶ Then carry out the teach-in process again.

³⁾ You can also use the installation wizards in SOPAS ET to perform the alignment work (see "System boundaries and status", page 95).
⁴⁾ The teach-in process can also be initiated via SOPAS ET, the integrated web server, or the PLC.

7 The MLG-2 on the PROFIBUS network

7.1 Overview

The MLG-2 ProNet supports DPV1 in compliance with IEC 61158.

	MLG-2	Q1	Address	Fieldbus module	
DPV1	MLGXXN-XXXXPXXX01	Presence	126(SSA)	FBM-P11	Standard ¹
DPV0	MLGXXN-XXXXPXXX02	Presence	126(SSA)	FBM-P12	Replacement MLG-1 ²

¹ Download existing GSD MLG-2 file from the Internet

² The existing GSD MLG-1 file can continue to be used

Architecture

All PROFIBUS subscribers are connected in a bus structure (line). Up to 32 subscribers can be interconnected as masters or slaves in one segment. The bus is terminated by an active bus terminator at the beginning and end of each segment.

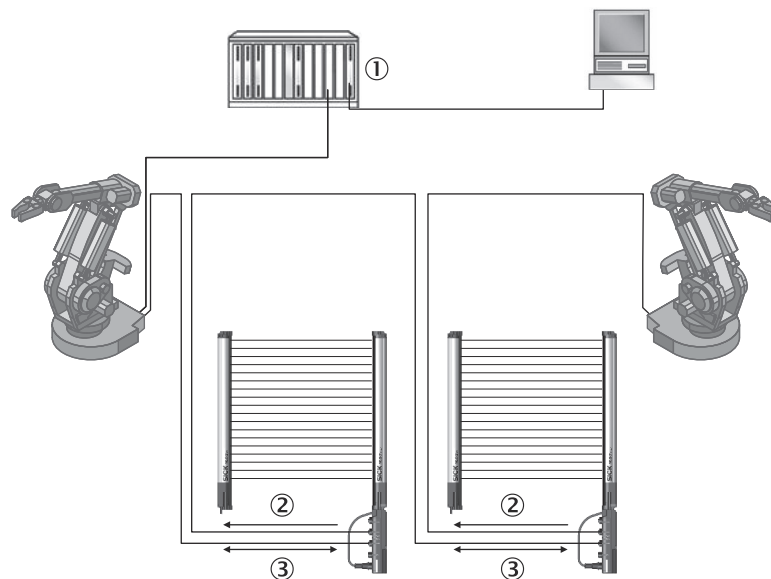

Figure 48: Example of PROFIBUS network in a bus structure (line)

- ① PLC
- ② Cyclic data (process data)
- ③ Acyclic data (service data)

The MLG-2 ProNet PROFIBUS is a PROFIBUS field device and is integrated into a PROFIBUS network as a slave. The MLG-2 consumes data of the master from the PROFIBUS (output data) and produces data for the PROFIBUS (input data).

Cyclic data (process data)

Modules are available as process data (see ["Cyclic data \(process data\)", page 63](#)) and are used to compose communication messages.

Acyclic data (service data)

Record Request and Record Response enable access to the MLG-2's object library.

The service data allow PROFIBUS field devices to be parameterized and configured, and can also be used to read out status information or process data. Communication takes place via PROFIBUS Read/Write Record Indication and Record Response.

In the Record Indication, a read or write command is sent for an index. The Record Response contains the answer to a request.

A Record Indication is transmitted from the master to the slave. The MLG-2 interprets this request and makes the data available.

The different data sets (objects) are addressed using indexes. An object's index specifies the data object within a slot/subslot.



NOTE

On the MLG-2, the data objects are not slot- or subslot-dependent. The only requirement is that valid slot/subslot/index addressing be used (e.g., 1/1/40h).

Once the MLG-2 has been integrated into PROFIBUS, the following steps can be performed:

- The MLG-2 device name can be set
- The device name can be used in the PLC
- Parameters can be set for the MLG-2
- Modules can be set for the process data

7.1.1 Addressing

A unique address must be assigned to each PROFIBUS slave for communication. The range of valid address is 1 through 125.

The following addresses are reserved:

- The address 0 is reserved for diagnostic tools such as programming devices.
- The address 126 is the default slave address. When this address is set, a different address must be assigned to enable communication with the slave.
- The address 127 is reserved for addressing all subscribers and for addressing groups.



NOTE

The address 126 is configured at the factory. All DIP switches are set to 0, which is why the address 126 is active. To properly integrate the MLG-2 in PROFIBUS, you must first set a different valid address.

The following addressing options are available:

- Addressing via DIP switches on the fieldbus module
- Addressing via SOPAS ET
- Addressing via PROFIBUS DP master

Addressing via DIP switches

Eight DIP switches are located under a cover on the fieldbus module (see ["Display and operating elements", page 31](#)). You can use these DIP switches to set the address for the MLG-2.

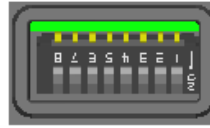

Figure 49: DIP switches 1 ... 8

Table 31: Value of the DIP switches

DIP switch ¹	7	6	5	4	3	2	1
Value in ON position	64	32	16	8	4	2	1
Value in OFF position	0	0	0	0	0	0	0

¹ DIP switch 8 has no function.

All DIP switches are set to 0 at the factory. If the address 0, 126, or 127 is set using the DIP switches, then the address configured using SSA or SOPAS ET will be used.

1. Set the device address in the range of 1 to 125 using DIP switches 1 to 7.
2. Switch the supply voltage off and then on again.
- ✓ The modified device address is now active.

Addressing via Set Slave Address (SSA)

The PROFIBUS function **Set Slave Address** is used for addressing via a PROFIBUS DP master. The address can be set with any DIP switch setting on the MLG, but this address will only also be used for communication with a DIP switch setting of 0, 126 or 127.

This function is also used to transfer the **No_Add_Chg** (No Address Change) parameter. If the **No_Add_Chg** status has been activated, then it is no longer possible to change the device address. You can deactivate the **No_Add_Chg** status by setting the value 255 using DIP switches 1 through 8 (all set to ON), and switching the voltage off and then on again.

The factory setting for the address is 126 with the **No_Add_Chg** status deactivated. In other words, you can change the device address.



NOTE

Restart the device after addressing.

Addressing via SOPAS ET

You can also set the address of the MLG-2 using SPOAS ET (see "System settings for PROFIBUS", page 105).

- The address can be set with any DIP switch setting on the MLG, but this address will only also be used for communication with a DIP switch setting of 0, 126 or 127.
- If the **No_Add_Chg** status has been activated via SSA, then it is no longer possible to change the device address using SOPAS ET.

In the **Address configuration** area, you can enter the **address** in the PROFIBUS. You can enter an address from 1 to 125 for the MLG-2.

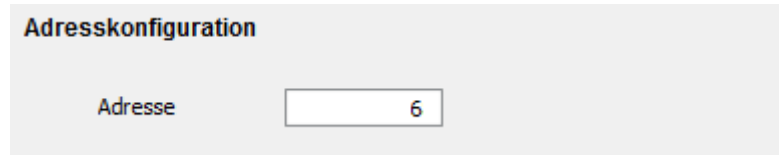

Figure 50: Address configuration in SOPAS ET

Baud rate

The MLG-2 supports the “Auto Baud Detection” function. With this function, the light grid is set to the baud rate specified by the PROFIBUS DP master.

7.1.2 GSD file

You can use a PROFIBUS configuration program to configure the light grid for your application. You will need the generic station description (GSD) to do so.

You can download the GSD file at www.sick.com:

1. Enter the seven-digit part number of your MLG-2 directly into the Search field on the homepage.
2. Click on the relevant search result.
- ✓ This will take you to all the information and files for your device.
3. Download the GSD file.
4. Integrate the GSD file into the engineering tool for your control.

A generic station description (GSD) contains a description of the properties of a PROFIBUS device, e.g., the data transmission rate supported by the device or the digital information the PLC receives from the device and the format of this information.

Replacement description: An MLG-1 (MLGX-XXXXP811) can be replaced by a MLGXXN-XXXXPXXX02 (with FBM-P22). The existing GSD file can continue to be used in the PLC.



NOTE

Only functions from the MLGX-XXXXP811 are available.

The MLGXXN-XXXXPXXX01 (from 2016) will be compatible with MLGX-XXXXP811 with a fieldbus module (FBM-P12).



NOTE

Please observe replacement document 8020350 (de) / 8020351 (en). Can be downloaded at www.sick.com.

If replacement is necessary (FBM-P22), GSD file “sick095B_V1.2” from the MLG-1 can be used.

7.2 Manufacturer-specific object library



NOTE

This chapter is only relevant for the FBM-P22.

Table 32: Nomenclature for access and data types

Abbreviation	Meaning
R	Read only access
R/W	Read/write access
STRG	String = a chain of characters of varying length
BOOL	Boolean = logical value 0 or 1

Abbreviation	Meaning
ENUM	Freely selectable values within a limited value range
UINT	Unsigned integer value (e. g., UINT-32 = 0 ... 4.294.967.295)
STRUCT	Sequence of data containing different data types (e. g., UINT-8, UINT-32, UINT-32, UINT-16)

Table 33: Process data indexes

Index	Access	Data type	Name
F0h	R	UINT-16	NBB – Number of Beams Blocked
F1h	R	UINT-16	NBM – Number of Beams Made
F2h	R	UINT-16	FBB – First Beam Blocked
F3h	R	UINT-16	FBM – First Beam Made
F4h	R	UINT-16	LBB – Last Beam Blocked
F5h	R	UINT-16	LBM – Last Beam Made
F6h	R	UINT-16	NCBB – Number of Consecutive Beams Blocked
F7h	R	UINT-16	NCBM – Number of Consecutive Beams Made
F8h	R	UINT-16	CBB – Central Beam Blocked
F9h	R	UINT-16	CBM – Central Beam Made
FAh	R	UINT-16	ODI – Outside Dimension
FBh	R	UINT-16	IDI – Inside Dimension
10h	R	UINT-16	Status of the switching output and the virtual switching outputs
11h	R	UINT-16	System status
12h	R	UINT-16	Process quality
13h	R	UINT-16	Teach-in quality
14h	R/W	UINT-8	Control
20h ... 2Fh	R	UINT-16	Run-length code
30h ... 3Fh	R	UINT-32	Beam status
C0h	R	UINT-16	NBB Zone 1 – Number of beams blocked in Zone 1
C1h	R	UINT-16	FBB Zone 1 – First beam blocked in Zone 1
C2h	R	UINT-16	LBB Zone 1 – Last beam blocked in Zone 1
C3h	R	UINT-16	NCBB Zone 1 – Number of consecutive beams blocked in Zone 1
C4h	R	UINT-16	CBB Zone 1 – Central beam blocked in Zone 1
C5h	R	UINT-16	NBB Zone 2 – Number of beams blocked in Zone 2
C6h	R	UINT-16	FBB Zone 2 – First beam blocked in Zone 2
C7h	R	UINT-16	LBB Zone 2 – Last beam blocked in Zone 2
C8h	R	UINT-16	NCBB Zone 2 – Number of consecutive beams blocked in Zone 2
C9h	R	UINT-16	CBB Zone 2 – Central beam blocked in Zone 2
CAh	R	UINT-16	NBB Zone 3 – Number of beams blocked in Zone 3
CBh	R	UINT-16	FBB Zone 3 – First beam blocked in Zone 3

Index	Access	Data type	Name
CCh	R	UINT-16	LBB Zone 3 – Last beam blocked in Zone 3
CDh	R	UINT-16	NCBB Zone 3 – Number of consecutive beams blocked in Zone 3
CEh	R	UINT-16	CBB Zone 3 – Central beam blocked in Zone 3
CFh	R	UINT-16	NBB Zone 4 – Number of beams blocked in Zone 4
D0h	R	UINT-16	FBB Zone 4 – First beam blocked in Zone 4
D1h	R	UINT-16	LBB Zone 4 – Last beam blocked in Zone 4
D2h	R	UINT-16	NCBB Zone 4 – Number of consecutive beams blocked in Zone 4
D3h	R	UINT-16	CBB Zone 4 – Central beam blocked in Zone 4
E0h	R	UINT-16	User defined
E1h	R	UINT-16	User defined
E0h	R	UINT-16	User defined
E0h	R	UINT-16	User defined

Table 34: Indexes for teach-in

Index	Access	Data type	Name
40h	R/W	BOOL	Teach-in
41h	R	UINT-8	Teach-in result
42h	R	BOOL	Teach-in required
43h	R/W	BOOL	Teach-in with blanking
44h	R/W	BOOL	Blank blocked beams
45h	R/W	BOOL	Blank beams made
46h ... 55h	R/W	UINT-32	Beam mask

Table 35: Indexes for defining operating mode/performance options

Index	Access	Data type	Name
60h	R/W	ENUM8	Operating mode
61h	R/W	ENUM8	Performance options
62h	R/W	ENUM8	Minimum detectable absorption
63h	R/W	STRUCT	Configuration Q1
64h	R/W	BOOL	Energy saving mode
65h	R/W	UINT-16	Switch-off delay Q1 in ms
66h	R/W	UINT-16	Switch-off delay Q2 in ms
67h	R/W	UINT-16	Switch-off delay Q3 in ms
68h	R/W	UINT-16	Switch-off delay Q4 in ms
69h	R/W	UINT-16	Switch-off delay Q5 through Q16 in ms

Table 36: Indexes with auxiliary resources and diagnostic options

Index	Access	Data type	Name
70h	R/W	BOOL	Alignment aid
71h	R	STRUCT	Values for alignment aid
72h	R/W	ENUM8	“Find Me” function
73h	R/W	BOOL	Pushbutton lock
74h	R/W	BOOL	Beam numbering

Index	Access	Data type	Name
75h	R/W	BOOL	Factory settings
76h	R/W	BOOL	Cloning upload
77h	R/W	BOOL	Cloning download
78h	R	ENUM8	Cloning status

Table 37: Indexes with system information

Index	Access	Data type	Name
80h	R	STRG (18)	Device name
81h	R	STRG (32)	Manufacturer name
82h	R	STRG (7)	Part number
83h	R	STRG (8)	Serial number
84h	R	STRG (64)	Product text
85h	R/W	STRG (32)	Mounting location
86h	R	STRUCT	Device characteristics
87h	R	STRG (4)	Hardware revision
88h	R	STRG (12)	Firmware version

Table 38: Indexes with beam evaluation

Index	Access	Data type	Name
90h	R/W	UINT-16	Zone measuring: First beam from Zone 1
91h	R/W	UINT-16	Zone measuring: Last beam from Zone 1
92h	R/W	UINT-16	Zone measuring: First beam from Zone 2
93h	R/W	UINT-16	Zone measuring: Last beam from Zone 2
94h	R/W	UINT-16	Zone measuring: First beam from Zone 3
95h	R/W	UINT-16	Zone measuring: Last beam from Zone 3
96h	R/W	UINT-16	Zone measuring: First beam from Zone 4
97h	R/W	UINT-16	Zone measuring: Last beam from Zone 4
98h	R/W	BOOL	Activate Cross beam measuring
99h	R/W	ENUM8	Activate BBH – Blocked Beams Hold
9Ah	R/W	STRUCT	BBH, beam function selection

**NOTE**

The compatibility modules are only used for replacing the previous MLG version with an MLG-2. Do not use these modules to implement new applications with the MLG-2.

Table 39: Compatibility modules

Access	Data type	Name
R	UINT-8	Beam functions with 8-bit length
R	UINT-8	Beam status with 8-bit length

**NOTE**

The FBM-P22 uses a Min_Slave_Interval of 6.

7.3 Cyclic data (process data)

Specify the required modules for the cyclic process data.

7.3.1 Modules with beam functions

NBB – Number of Beams Blocked

Table 40: NBB

Index	Access	Data type	Description
F0h	R	UINT-16	This module transfers the number of blocked beams.

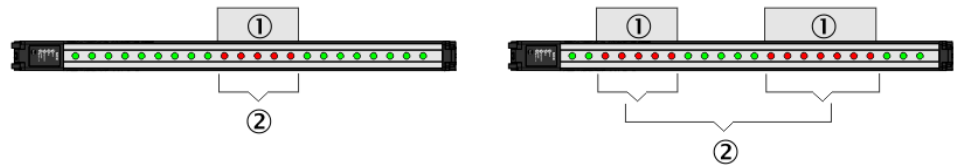

Figure 51: Beam function NBB

- ① Objects in detection area
- ② Number of beams blocked

The beam function facilitates object detection, for example.

- If there are several objects in the detection area (example on right), then all blocked beams are totaled.

NBM – Number of Beams Made

Table 41: NBM

Index	Access	Data type	Description
F1h	R	UINT-16	This module transfers the number of beams made.

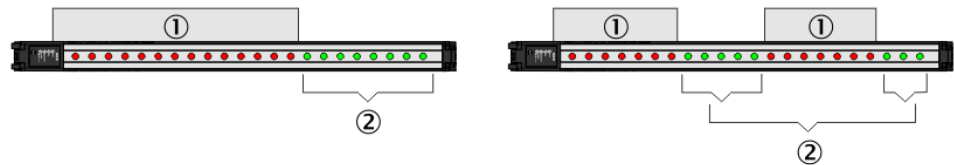

Figure 52: Beam function NBM

- ① Objects in detection area
- ② Number of beams made

The beam function facilitates hole detection, for example.

- If there are several gaps in the detection area (example on right), then all beams made are totaled.

FBB – First Beam Blocked

Table 42: FBB

Index	Access	Data type	Description
F2h	R	UINT-16	This module transfers the number of the first beam blocked.

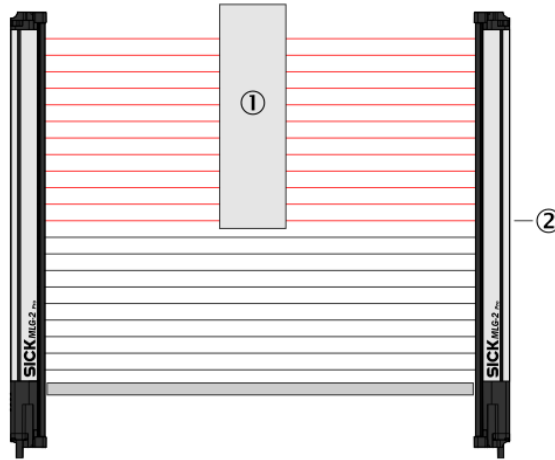

Figure 53: Beam function FBB

- ① Object in detection area
- ② First Beam Blocked

The beam function facilitates the height classification of a hanging object, for example.

- The count direction of the beams depends on the configured beam numbering.

FBM – First Beam Made

Table 43: FBM

Index	Access	Data type	Description
F3h	R	UINT-16	This module transfers the number of the first beam made.

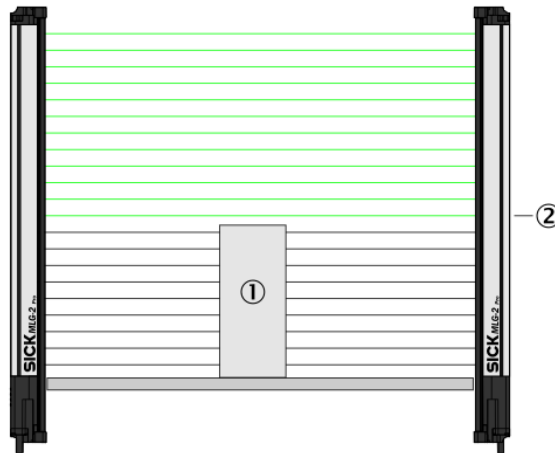

Figure 54: Beam function FBM

- ① Object in detection area
- ② First Beam Made

The beam function facilitates the height classification of a standing object, for example.

- The count direction of the beams depends on the configured beam numbering.

LBB – Last Beam Blocked

Table 44: LBB

Index	Access	Data type	Description
F4h	R	UINT-16	This module transfers the number of the last beam blocked.

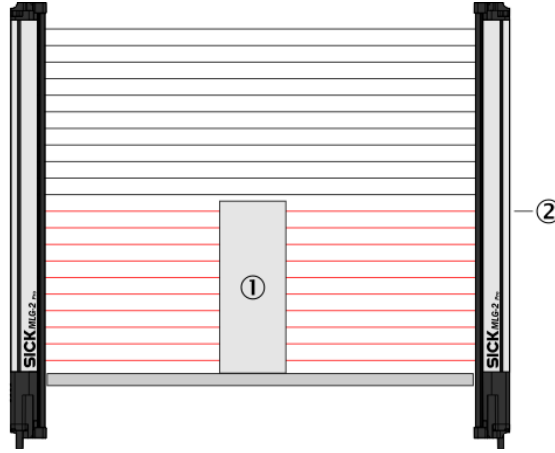

Figure 55: Beam function LBB

- ① Object in detection area
- ② Last Beam Blocked

The beam function facilitates object height measurement, for example.

- The count direction of the beams depends on the configured beam numbering.

LBM – Last Beam Made

Table 45: LBM

Index	Access	Data type	Description
F5h	R	UINT-16	This module transmits the number of the last beam made.

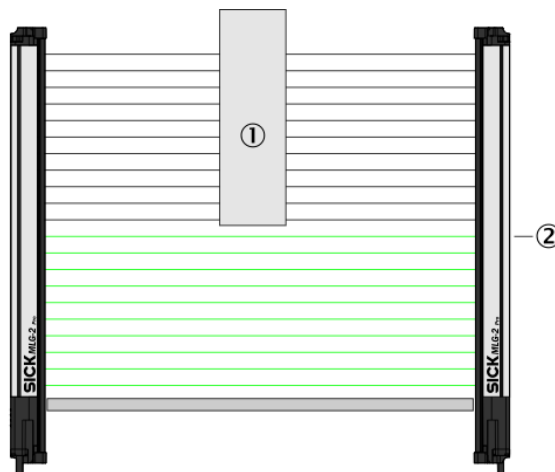

Figure 56: Beam function LBM

- ① Object in detection area
- ② Last beam made

The beam function facilitates the object measurement of a hanging object, for example.

- The count direction of the beams depends on the configured beam numbering.

NCBB – Number of Consecutive Beams Blocked

Table 46: NCBB

Index	Access	Data type	Description
F6h	R	UINT-16	This module transfers the total number of consecutive beams blocked.

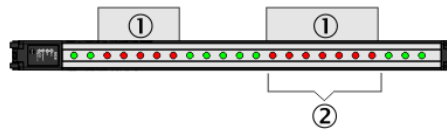

Figure 57: Beam function NCBB

- ① Objects in detection area
- ② Total number of consecutive beams blocked

The beam function facilitates object detection, for example.

- If there are several objects in the detection area, the number of beams of the largest object is output.
- If there are several objects of the same size in the detection area, the object with the lowest-value beam is used for the measurement.

NCBM – Number of Consecutive Beams Made

Table 47: NCBM

Index	Access	Data type	Description
F7h	R	UINT-16	This module transfers the total number of consecutive beams made.

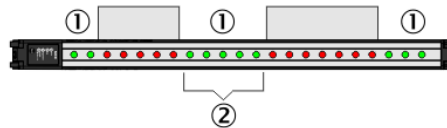

Figure 58: Beam function NCBM

- ① Gaps in detection area
- ② Total number of consecutive beams made

The beam function facilitates hole detection, for example.

- If there are several gaps in the detection area, the number of beams of the largest free field is output.
- If there are several gaps of the same size in the detection area, the gap with the lowest-value beam is used for the measurement.

CBB – Central Beam Blocked

Table 48: CBB

Index	Access	Data type	Description
F8h	R	UINT-16	This module transfers the beam number of the central beam blocked.

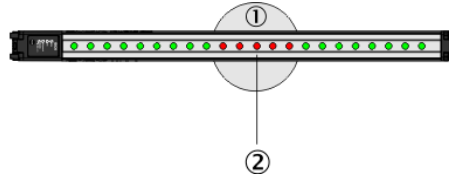

Figure 59: Beam function CBB

- ① Object in detection area
- ② Central Beam Blocked

The beam function facilitates object position measurement, for example.

- The count direction of the beams depends on the configured beam numbering.
- If the object blocks an even number of beams, the lowest-value beam of the “two central beams” is rated as the central beam blocked.
- If there are several objects in the detection area, the largest object is used for the measurement.

CBM – Central Beam Made

Table 49: CBM

Index	Access	Data type	Description
F9h	R	UINT-16	This module transfers the beam number of the central beam made.

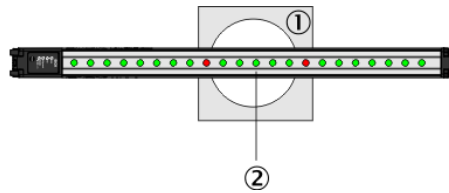

Figure 60: Beam function CBM

- ① Object in detection area
- ② Central beam made

The beam function facilitates hole position measurement, for example.

- The count direction of the beams depends on the configured beam numbering.
- If the hole makes an even number of beams, the lowest-value beam of the “two central beams” is rated as the central beam made.
- If there are several holes in the detection area, the largest hole is used for the measurement.

ODI – Outside Dimension

Table 50: ODI

Index	Access	Data type	Description
FAh	R	UINT-16	This module transfers the outside dimension of an object.

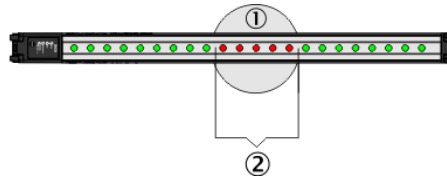

Figure 61: Beam function ODI

- ① Object in detection area
- ② Outside dimension

The beam function facilitates outside dimension measurement, for example.

- If there are several objects in the detection area, then the blocked beams of the objects are totaled.

IDI – Inside Dimension

Table 51: IDI

Index	Access	Data type	Description
FBh	R	UINT-16	This module transfers the inside dimension of an object.

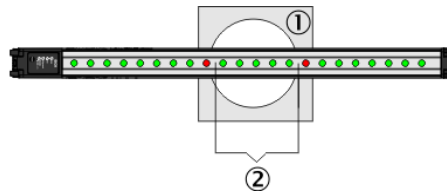

Figure 62: Beam function IDI

- ① Object in detection area
- ② Inside dimension

The beam function facilitates inside dimension measurement of a hole, for example.

- If there are several holes in the detection area, then the beams made within the objects are totaled.

RLC – Run-length code

Table 52: RLC – Run-length code

Index	Access	Data type	Description
20h ... 2Fh	R	UINT-16	These modules transfer the run-length code of the MLG-2. 20h ... 2Fh 21h = RLC2 ... 2Fh = RLC16

The “run-length code” can be output instead of the complete status of all beams. This code only contains the status change of the beams.



NOTE

The run-length code can contain a maximum of 16 values, i.e., 15 status changes. It is therefore only useful for measuring objects with a small number of parts, e.g., a pallet. Objects such as pallet cages are not suitable as they involve too many status changes.

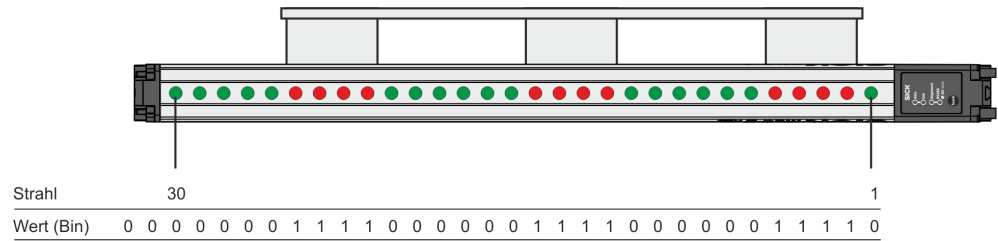

Figure 63: Beam status – Example 1

- The green beams have been made.
- The red beams have been blocked.
- The bits represent the status of the beams on the MLG-2 (made = logical 0, broken = logical 1).
- The count direction of the beams depends on the configured beam numbering (in the example, beam 1 on the connection side).

The run-length code indicates how many beams currently have the same status.

Table 53: Example run-length code with 30 beams

Beams 1 ... 30																																				
0	1	1	1	1	0	0	0	0	0	0	1	1	1	1	0	0	0	0	0	1	1	1	1	0	0	0	0	1	1	1	1	0	0	0	0	0
RLC1	RLC2				RLC3						RLC4				RLC5						RLC6				RLC8											
1	4				6						4				6						4				5											

RLC = 1464645

The example shows: 1 beam made, 4 beams blocked, 6 beams made, 4 beams blocked, 6 beams made, 4 beams blocked, 5 beams made.

Table 54: Example run-length code with the first beam blocked

Beams 1 ... 30																																							
-	1	1	1	1	1	0	0	0	0	0	0	1	1	1	1	0	0	0	0	0	0	1	1	1	1	0	0	0	0	0	1	1	1	1	0	0	0	0	0
RLC1	RLC2				RLC3						RLC4				RLC5						RLC6				RLC8														
0	5				6						4				6						4				5														

RLC = 0564645

The RLC1 **always** indicates the number of beams **made**. If the first beam is blocked, the RLC1 will therefore be zero. Only the RLC2 indicates how many beams are blocked; in the example, this value = 5.

Beam status

Table 55: Beam status

Index	Access	Data type	Description
30h ... 3Fh	R	UINT-32	These modules transfer the status of the beams of the MLG-2. 30h: beam 1 - 32. 31h: beam 33 - 64. ... 3Fh: beam 481 - 512.

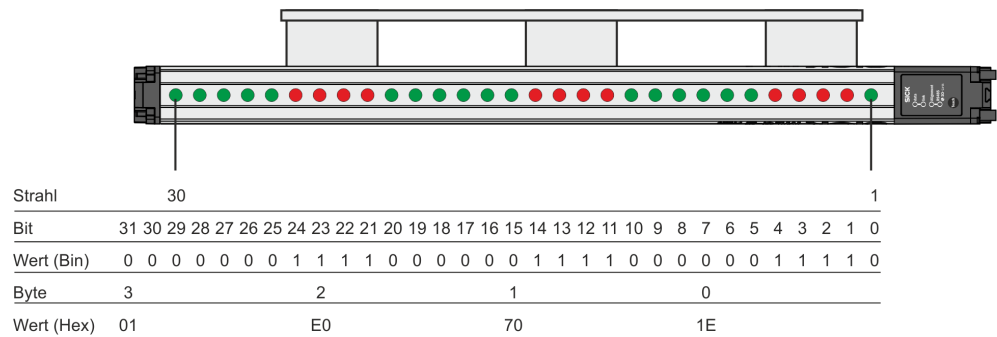

Figure 64: Beam status – Example 2

This example shows an MLG-2 with 30 beams.

- The green beams have been made.
- The red beams have been blocked.
- The bits represent the status of the beams on the MLG-2 (made = logical 0, broken = logical 1).
- Beam 1 is represented by bit 0; beam 30 by bit 29.
- Superfluous bits receive the status logical 0 (in the example, bits 30 and 31).
- The count direction of the beams depends on the configured beam numbering (in the example, beam 1 on the connection side).

Zone measuring beam functions

Table 56: Beam functions for Zone measuring

Index	Access	Data type	Name	Description
C0h	R	UINT-16	NBB Zone 1 – Number of beams blocked in Zone 1	This module transfers the number of blocked beams in Zone 1.
C1h	R	UINT-16	FBB Zone 1 – First beam blocked in Zone 1	This module transfers the number of the first beam blocked in Zone 1.
C2h	R	UINT-16	LBB Zone 1 – Last beam blocked in Zone 1	This module transfers the number of the last beam blocked in Zone 1.
C3h	R	UINT-16	NCBB Zone 1 – Number of consecutive beams blocked in Zone 1	This module transfers the total number of consecutive beams blocked in Zone 1.
C4h	R	UINT-16	CBB Zone 1 – Central beam blocked in Zone 1	This module transfers the beam number of the central beam blocked in Zone 1.
C5h	R	UINT-16	NBB Zone 2 – Number of beams blocked in Zone 2	This module transfers the number of blocked beams in Zone 2.
C6h	R	UINT-16	FBB Zone 2 – First beam blocked in Zone 2	This module transfers the number of the first beam blocked in Zone 2.
C7h	R	UINT-16	LBB Zone 2 – Last beam blocked in Zone 2	This module transfers the number of the last beam blocked in Zone 2.
C8h	R	UINT-16	NCBB Zone 2 – Number of consecutive beams blocked in Zone 2	This module transfers the total number of consecutive beams blocked in Zone 2.

Index	Access	Data type	Name	Description
C9h	R	UINT-16	CBB Zone 2 – Central beam blocked in Zone 2	This module transfers the beam number of the central beam blocked in Zone 2.
CAh	R	UINT-16	NBB Zone 3 – Number of beams blocked in Zone 3	This module transfers the number of blocked beams in Zone 3.
CBh	R	UINT-16	FBB Zone 3 – First beam blocked in Zone 3	This module transfers the number of the first beam blocked in Zone 3.
CCh	R	UINT-16	LBB Zone 3 – Last beam blocked in Zone 3	This module transfers the number of the last beam blocked in Zone 3.
CDh	R	UINT-16	NCBB Zone 3 – Number of consecutive beams blocked in Zone 3	This module transfers the total number of consecutive beams blocked in Zone 3.
CEh	R	UINT-16	CBB Zone 3 – Central beam blocked in Zone 3	This module transfers the beam number of the central beam blocked in Zone 3.
CFh	R	UINT-16	NBB Zone 4 – Number of beams blocked in Zone 4	This module transfers the number of blocked beams in Zone 4.
D0h	R	UINT-16	FBB Zone 4 – First beam blocked in Zone 4	This module transfers the number of the first beam blocked in Zone 4.
D1h	R	UINT-16	LBB Zone 4 – Last beam blocked in Zone 4	This module transfers the number of the last beam blocked in Zone 4.
D2h	R	UINT-16	NCBB Zone 4 – Number of consecutive beams blocked in Zone 4	This module transfers the total number of consecutive beams blocked in Zone 4.
D3h	R	UINT-16	CBB Zone 4 – Central beam blocked in Zone 4	This module transfers the beam number of the central beam blocked in Zone 4.

User defined

These modules are reserved for use at a later point in time and currently cannot be used.

Table 57: User defined

Index	Access	Data type	Name
E0h	R	UINT-16	User defined 1
E1h	R	UINT-16	User defined 2
E2h	R	UINT-16	User defined 3
E3h	R	UINT-16	User defined 4

7.3.2 Modules with system information

QS – Switching output status

Table 58: QS – Switching output status

Index	Access	Data type	Description
10h	R	UINT-16	This module transfers the status of switching output Q1 and the statuses of virtual switching outputs Q2 ... Q16. Bit 0 = Q1 (physical output) Bit 1 ... 15 = Q2 ... Q16 (virtual outputs) 0 = output not active 1 = output active

The status of a switching output depends on the following factors:

- The application assigned in SOPAS ET
- The function programming assigned in SOPAS ET or in the fieldbus functions

The following is set at the factory:

- Switching output Q1 = NBB ≥1
- Virtual switching outputs = no function



NOTE

These virtual switching outputs can only be configured in SOPAS ET (see "[Measuring and diagnostic functions for switching outputs](#)", page 105).

SYS – System status

Table 59: SYS – System status

Index	Access	Data type	Description
11h	R	UINT-16	This module transfers the system status of the MLG-2.

The system status is stored in 8 bit:

Table 60: Details of the system status

Bit 15 ... 8	Bit 7	Bit 6	Bit 5	Bit 4	Bit 3	Bit 2	Bit 1	Bit 0
Reserved	Synchronization error	Teach-in error	Hardware error	Contamination	Teach-in active	Overtemperature	Process data invalid	Short-circuit at switching output

QoR – Quality of Run (process quality)

Table 61: QoR – Quality of Run

Index	Access	Data type	Description
12h	R	UINT-16	This module transfers the process quality of the MLG-2 in percent. 00h = 0% 64h = 100%

The process quality indicates the quality of the light level currently being received. The MLG-2 analyzes the light level received when the light path is unblocked and compares this to the values after the last teach-in process.

If the received values are getting worse, the process quality drops.

Possible causes of a drop in process quality include:

- Contamination or fogging of the front screen of the sender and/or receiver
- Misalignment
- Continuous partial blocking of a light beam or several light beams

QoT – Quality of Teach (teach-in quality)

Table 62: QoT – Quality of Teach (teach-in quality)

Index	Access	Data type	Description
13h	R	UINT-16	This module transfers the quality of the last teach-in process. 00h = unsuccessful 64h = successful

The teach-in quality indicates how successful the teach-in process has been. The MLG-2 calculates this value based on the quality of the light level received.

The value remains constant until another teach-in process is carried out.

7.3.3 Modules for initiating operating functions

7.3.3.1 Control

Table 63: Control

Object	Access	Data type	Description
14h	R/W	UINT-8	This object is used to initiate operating functions on the MLG-2.

The object's individual functions are stored in 8-bit:

Table 64: Details

Bit 7	TEST – Sender dark switching <ul style="list-style-type: none"> • 0 = normal light grid function • 1 = TEST active, i.e. the sender is switched off
Bit 6	TEACH-IN – Sensitivity teach-in <ul style="list-style-type: none"> • 0 = one-time sensitivity teach-in not active • 1 = one-time sensitivity teach-in active
Bit 5	BBH – Blocked Beams Hold (saves blocked beams) <ul style="list-style-type: none"> • 0 = Blocked Beams Hold deactivated • 1 = Blocked Beams Hold activated
Bit 4	Reserved
Bit 3	Reserved
Bit 2	SB – Standby (The sender is switched off. The beam status, basic functions and switching output are maintained. These are invalid, since the light grid does not perform measurements.) <ul style="list-style-type: none"> • 0 = standby deactivated • 1 = standby activated
Bit 1	Reserved
Bit 0	Reserved

7.3.4 Compatibility objects for the preceding version

To replace the existing MLG with the MLG-2 ProNet PROFIBUS, the MLG-2 supports the output of beam functions and beam status with 8-bit length.

Use the FBM-P22 for complete compatibility.

**NOTE**

These objects are only used for replacing the previous MLG version with an MLG-2. Do not use these objects to implement new applications with the MLG-2.

7.3.4.1 Beam status with 8-bit length**NOTE**

The modules with 8-bit length can be used to output the beam statuses of a maximum of 240 beams.

Table 65: Beam status

Access	Data type	Description
R	UINT-8	These modules transfer the status of the beams of the MLG-2. Byte 0: bit 0 = beam 8 ... bit 7 = beam 1. Byte 1: bit 0 = beam 16 ... bit 7 = beam 9. ... Byte 29: bit 0 = beam 240 ... bit 7 = beam 233.

7.3.4.2 Beam functions with 8-bit length

To replace the existing MLG PROFIBUS, the MLG-2 supports the output of beam functions and beam status with 8-bit length.

8 Bit – NBB (Number of Beams Blocked)

Table 66: NBB

Access	Data type	Description
R	UINT-8	This module transfers the number of blocked beams.

8 Bit – NBM (Number of Beams Made)

Table 67: NBM

Access	Data type	Description
R	UINT-8	This module transfers the number of beams made.

8 Bit – FBB (First Beam Blocked)

Table 68: FBB

Access	Data type	Description
R	UINT-8	This module transfers the number of the first beam blocked.

8 Bit – FBM (First Beam Made)

Table 69: FBM

Access	Data type	Description
R	UINT-8	This module transfers the number of the first beam made.

8 Bit – LBB (Last Beam Blocked)

Table 70: LBB

Access	Data type	Description
R	UINT-8	This module transfers the number of the last beam blocked.

8 Bit – LBM (Last Beam Made)

Table 71: LBM

Access	Data type	Description
R	UINT-8	This module transmits the number of the last beam made.

8 Bit – NCB (Number of Consecutive Beams Blocked)

Table 72: NCB

Access	Data type	Description
R	UINT-8	This module transfers the total number of consecutive beams blocked.

8 Bit – NCBM (Number of Consecutive Beams Made)

Table 73: NCBM

Access	Data type	Description
R	UINT-8	This module transfers the total number of consecutive beams made.

8 Bit – CBB (Central Beam Blocked)

Table 74: CBB

Access	Data type	Description
R	UINT-8	This module transfers the beam number of the central beam blocked.

8 Bit – CBM (Central Beam Made)

Table 75: CBM

Access	Data type	Description
R	UINT-8	This module transfers the beam number of the central beam made.

8 Bit – ODI (Outside Dimension)

Table 76: ODI

Access	Data type	Description
R	UINT-8	This module transfers the outside dimension of an object.

8 Bit – IDI (Inside Dimension)

Table 77: IDI

Access	Data type	Description
R	UINT-8	This module transfers the inside dimension of an object.

7.4 Acyclic data (service data)

Communication is via the Request parameter and the Response parameter. In the Request parameter, a read or write command is sent for one or more parameters. The Response parameter contains the answer to the request concerned.

A Request is transferred from the master to the slave. The MLG-2 interprets the Request parameter and makes data available.

7.4.1 Parameters for the teach-in function

7.4.1.1 Teach-in

Table 78: Teach-in

Index	Access	Data type	Description
40h	R/W	BOOL	This parameter is used to start a teach-in on the MLG-2. 0 = no teach-in 1 = start teach-in A change from 0 to 1 always initiates a teach-in. If an additional teach-in is to be initiated, this index must first be described using 0.

During the teach-in process, the switching thresholds for all beams are individually adjusted for the sensing range and the ambient conditions.

A teach-in process must be carried out when commissioning, when changing operating mode or performance options, and at regular intervals in general.

7.4.1.2 Teach-in result

Table 79: Teach-in result

Index	Access	Data type	Description
41h	R	UINT-8	This parameter is used to read the result of the last teach-in.

The teach-in result is stored in 8 bit:

Table 80: Teach-in result – Stored in 8 bit

Bit 7	Bit 6	Bit 5	Bit 4	Bit 3	Bit 2	Bit 1	Bit 0
Warning: no automatic teach-in possible	Error: occurred when blanking beams during teach-in	Warning: high-speed scan not possible	Error: occurred with cross-beam function during teach-in	Warning: beam signal strength too high	Warning: beam signal strength too low	Error: occurred with parallel-beam function during teach-in	Error: general error occurred during teach-in

7.4.1.3 Teach-in required

Table 81: Teach-in required

Index	Access	Data type	Description
42h	R	BOOL	This parameter is used to read whether a teach-in is required. 0 = no teach-in required 1 = teach-in required

7.4.1.4 Teach-in with blanking

Table 82: Teach-in with blanking

Index	Access	Data type	Description
43h	R/W	BOOL	This parameter activates beam blanking for each teach-in. 0 = no blanking 1 = with blanking

To show the blanked beams again, proceed as follows:

1. Remove all objects from the detection area.
2. Activate the **Blank blocked beams** function.
3. Activate the **Teach-in with blanking** function.
4. Perform a teach-in.

7.4.1.5 Blank blocked beams

Table 83: Blank blocked beams

Index	Access	Data type	Description
44h	R/W	BOOL	This parameter is used to blank the blocked beams for later measurements. 0 = no blanking 1 = blank the beams A change from 0 to 1 always initiates a blanking of blocked beams. If the beams are to be blanked again, this index must first be described using 0.

The beams from the MLG-2 that are **not** to be accounted for in the measurement must be blocked.

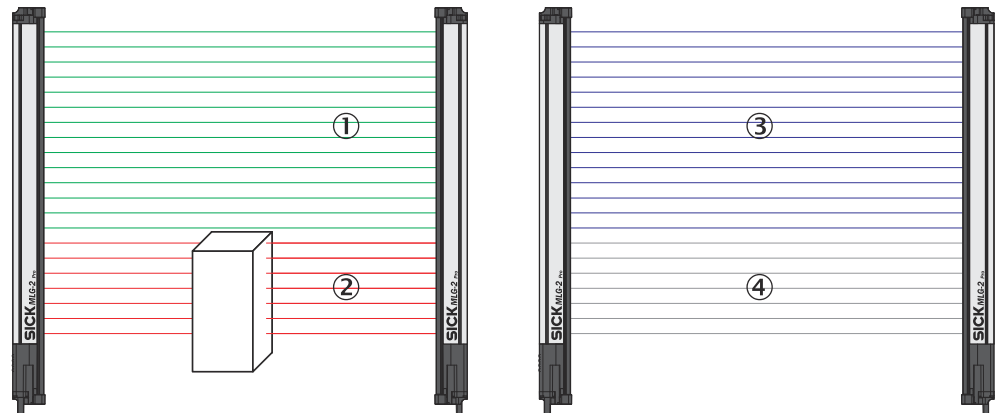

Figure 65: Example of the blanking of blocked beams

- ① Made beams
- ② Blocked beams
- ③ Beams included in the measurement
- ④ Excluded beams

7.4.1.6 Blank beams made

Table 84: Blank beams made

Index	Access	Data type	Description
45h	R/W	BOOL	This parameter is used to blank the made beams for later measurements. 0 = no blanking 1 = blank the beams A change from 0 to 1 always initiates a blanking of beams made. If the beams are to be blanked again, this index must first be described using 0.

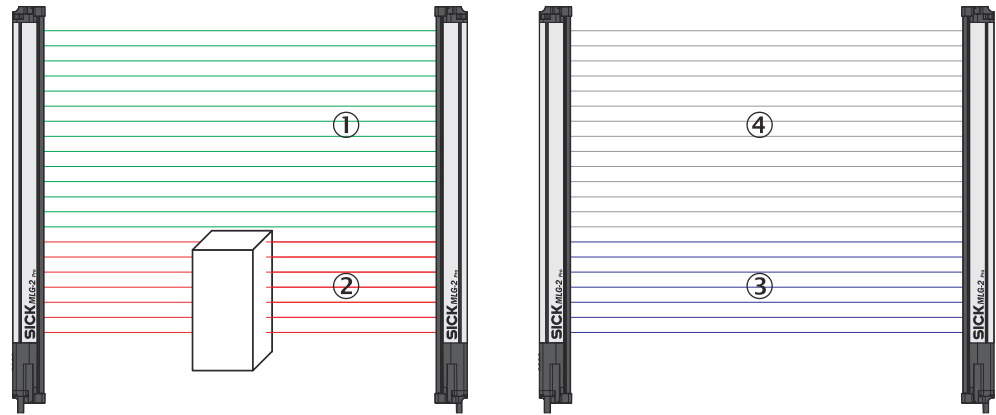

Figure 66: Example of blanking made beams

- ① Made beams
- ② Blocked beams
- ③ Beams included in the measurement
- ④ Excluded beams

The made beams will not be taken into account in the measurement.

7.4.1.7 Beam mask

Table 85: Beam mask

Index	Access	Data type	Description
46h ... 55h	R	UINT-32	These parameters are used to blank the beams from the MLG-2 for measurement purposes. 46h contains beams 1 ... 32 47h contains beams 33 ... 64 ... 55h contains beams 481 ... 512 0 = beam is blanked 1 = beam is included in the measurement

The beams can be blanked using a bit-coded beam mask. This example shows the bit-coded beam mask for an MLG-2, with 30 beams.

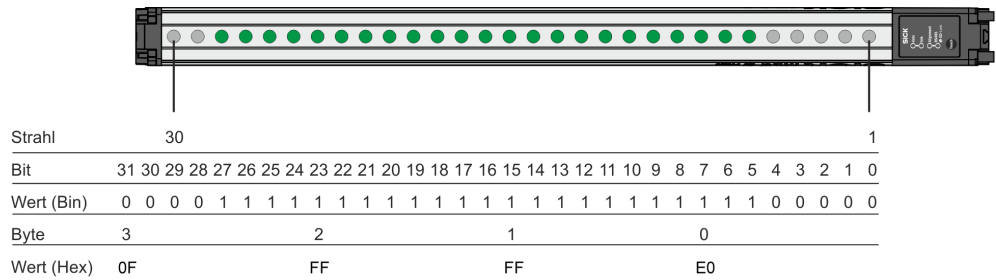

Figure 67: Bit-coded beam mask for an MLG-2, with 30 beams

7.4.2 Parameters for definition of operating mode and performance options

7.4.2.1 Operating mode



NOTE

This chapter is only relevant for the FBM-P22.

Table 86: Operating mode

Index	Access	Data type	Description
60h	R/W	ENUM8	This parameter sets the MLG-2 to the respective operating mode. 0 = standard 1 = transparent 2 = dust- and sunlight-resistant

The MLG-2 has the following operating modes:

- Standard
For normal measuring tasks involving opaque objects (recommended for the majority of applications)
- Transparent
For transparent objects, e.g., made of glass, PET, etc.
- Dust- and sunlight-resistant
For applications when there is a large amount of dust in the environment or a high level of solar radiation



NOTE

When the operating mode is changed, a new teach-in process must be performed.

7.4.2.2 Performance options

Table 87: Performance options

Index	Access	Data type	Description
61h	R/W	ENUM8	This parameter specifies the performance options of the MLG-2. 0 = standard measurement accuracy 1 = high measurement accuracy 2 = high operating reserve 3 = cross-beam function 4 = cross-beam function with high operating reserve 5 = high-speed scan 6 = high-speed scan with high measurement accuracy 7 = high-speed scan with high operating reserve

Standard measurement accuracy

In order for an object to be detected, it must completely cover at least one beam (see "[Minimum detectable object with parallel-beam function](#)", page 20).

High measurement accuracy

On the MLG-2, the measurement accuracy can be increased in SOPAS ET. This means that an object can be detected even if it only covers half of a beam (see "Minimum detectable object with high measurement accuracy from the MLG-2", page 23). When the configured measurement accuracy is high, the MLG-2 cleaning and teach-in processes must be performed more frequently.

High operating reserve

Setting the operating reserve high makes the MLG-2 very resistant to contamination (see "Operating reserve", page 24). However, it is not possible to activate high measurement accuracy in this case.

Cross beam function

When the cross-beam function is enabled, the light beam from a sender LED is received by three receiver diodes in two scans. This doubles the scan time.(see "Minimum detectable object with cross-beam function ", page 22).

High-speed scan

With high-speed scan, several beams are active in each cycle. This reduces the scan time by a variable factor (see "Scan time with high-speed scan on the MLG-2", page 19).

7.4.2.3 Minimum detectable absorption

Table 88: Minimum detectable absorption

Index	Access	Data type	Description
62h	R/W	ENUM8	This parameter is used to specify the minimum detectable absorption for the Transparent operating mode (see "Transparent operating mode", page 24). 0 = signal attenuation 30% 1 = signal attenuation 15% 2 = signal attenuation 10%

7.4.2.4 Configuration Q1

Table 89: Configuration Q1

Index	Access	Data type	Description
63h	R/W	STRUCT Operand 1 = ENUM8 Operator = ENUM8 Operand 2 = UINT-16	These parameters are used to define function programming for switching output Q1.

Table 90: Byte sequence of 63h

Byte 0	Byte 1	Byte 2	Byte 3
Operand 1	Operator	Operand 2	
ENUM8	ENUM8	UINT-16	

You can use operands and operators to realize functions for the switching output.

Example:

Operand 1 = 2; equates to the number of beams made (NBM)

Operator = 1; equates to \geq

Operand 2 = 30

Output Q1 switches when the total number of beams made is greater than or equal to 30.

Operand 1

Table 91: Selectable beam functions

Value	Name	Description
0	NBB	Total number of beams blocked (e.g., for object detection)
1	NBM	Total number of beams made (e.g., for hole detection)
2	FBB	Beam number of the first beam blocked (e.g., for height classification of a hanging object)
3	FBM	Beam number of the first beam made
4	LBB	Beam number of the last beam blocked (e.g., for object height measurement)
5	LBM	Beam number of the last beam made
6	NCBB	Number of consecutive beams blocked (e.g., for object detection). If there are multiple objects in the detection area, the greatest number of consecutive beams blocked is displayed.
7	NCBM	Number of consecutive beams made (e.g., for hole detection). If there are multiple gaps in the detection area, the greatest number of consecutive beams made is displayed.
8	CBB	Beam number of the central beam blocked (e.g., for measuring an object position)
9	CBM	Beam number of the central beam made (e.g., for measuring a hole position)
10	ODI	Total number of beams between the first and last beams blocked (e.g., for measuring the outside dimension)
11	IDI	Total number of beams made between the first and last beams blocked (e.g., for measuring the inside dimension)
12	BNB	True when a predefined beam is blocked
13	BNM	True when a predefined beam is made
14	ALARM Q1	Configuration same as with SOPAS ET
15	QoR (process quality)	0 ... 100 in percent
16	QoT (teach-in quality)	0 or 100 in percent 0 = teach-in was unsuccessful 100 = teach-in was successful
17 ... 32	RLC1 ... 16	Outputs the value of the relevant change
33	NBB Zone 1	Total number of beams blocked in Zone 1 (e.g., for object detection)
34	FBB Zone 1	Beam number of the first beam blocked in Zone 1 (e.g., for height classification of a hanging object)
35	LBB Zone 1	Beam number of the last beam blocked in Zone 1 (e.g., for object height measurement)

Value	Name	Description
36	NCBB Zone 1	Number of consecutive beams blocked in Zone 1 (e.g., for object detection). If there are multiple objects in the detection area, the greatest number of consecutive beams blocked is displayed.
37	CBB Zone 1	Beam number of the central beam blocked in Zone 1 (e.g., for measuring an object position)
38	NBB Zone 2	Total number of beams blocked in Zone 2 (e.g., for object detection)
39	FBB Zone 2	Beam number of the first beam blocked in Zone 2 (e.g., for height classification of a hanging object)
40	LBB Zone 2	Beam number of the last beam blocked in Zone 2 (e.g., for object height measurement)
41	NCBB Zone 2	Number of consecutive beams blocked in Zone 2 (e.g., for object detection). If there are multiple objects in the detection area, the greatest number of consecutive beams blocked is displayed.
42	CBB Zone 2	Beam number of the central beam blocked in Zone 2 (e.g., for measuring an object position)
43	NBB Zone 3	Total number of beams blocked in Zone 3 (e.g., for object detection)
44	FBB Zone 3	Beam number of the first beam blocked in Zone 3 (e.g., for height classification of a hanging object)
45	LBB Zone 3	Beam number of the last beam blocked in Zone 3 (e.g., for object height measurement)
46	NCBB Zone 3	Number of consecutive beams blocked in Zone 3 (e.g., for object detection). If there are multiple objects in the detection area, the greatest number of consecutive beams blocked is displayed.
47	CBB Zone 3	Beam number of the central beam blocked in Zone 3 (e.g., for measuring an object position)
48	NBB Zone 4	Total number of beams blocked in Zone 4 (e.g., for object detection)
49	FBB Zone 4	Beam number of the first beam blocked in Zone 4 (e.g., for height classification of a hanging object)
50	LBB Zone 4	Number of consecutive beams blocked in Zone 4 (e.g., for object detection). If there are multiple objects in the detection area, the greatest number of consecutive beams blocked is displayed.
51	NCBB Zone 4	Beam number of the central beam blocked in Zone 4 (e.g., for measuring an object position)
52	CBB Zone 4	Total number of beams blocked in Zone 4 (e.g., for object detection)
53	User defined 1	User defined 1
54	User defined 2	User defined 2
55	User defined 3	User defined 3
56	User defined 4	User defined 4

Operator

0 equates to =

1 equates to ≥

2 equates to ≤

3 equates to ≠

Operand 2

0 ... 510

7.4.2.5 Energy saving mode

Table 92: Energy saving mode

Index	Access	Data type	Description
64h	R/W	BOOL	This parameter is used to activate standby mode. 0 = standby not active 1 = standby active

In order to reduce energy consumption, the MLG-2 can be set to standby mode.

Standby mode freezes the status of the outputs, i.e., they do not change their status even when objects enter or leave the detection area.

7.4.2.6 Switch-off delay

You can use the switch-off delay to adjust the output from the switching outputs so that it matches the installed PLC. You can set one individual switch-off delay each for switching outputs Q1 through Q4, and one shared switch-off delay for switching outputs Q5 through Q16.

The delays set here will also affect the bits in the “QS- Switching output status” process data.

Table 93: Switch-off delay

Index	Access	Data type	Description
65h	R/W	UINT-16	This parameter is used to set a delay for switching output Q1.
66h	R/W	UINT-16	This parameter is used to set a delay for switching output Q2.
67h	R/W	UINT-16	This parameter is used to set a delay for switching output Q3.
68h	R/W	UINT-16	This parameter is used to set a delay for switching output Q4.
69h	R/W	UINT-16	This parameter is used to set a shared delay for switching outputs Q5 through Q16.

7.4.3 Parameters with auxiliary resources and diagnostic options**7.4.3.1 Alignment aid**

Table 94: Alignment aid

Index	Access	Data type	Description
70h	R/W	BOOL	This parameter activates the alignment aid of the MLG-2. 0 = alignment aid not active 1 = alignment aid active

7.4.3.2 Values for alignment aid

Table 95: Values for alignment aid

Index	Access	Data type	Description
71h	R	STRUCT 3 × UINT-8	This parameter is used to read the values for certain beams on the MLG-2. Component 1 contains the value for the beam on the connection side. Component 2 contains the value for the beam on the end cap. Component 3 contains the value for the beam most heavily contaminated.

100% signal strength equates to value 100d

0% signal strength equates to value 0d

7.4.3.3 “Find Me” function

Table 96: “Find Me” function

Index	Access	Data type	Description
72h	R/W	ENUM8	This parameter activates the “Find Me” function on the MLG-2. 0 = function not active 1 = function active

The three LEDs on the front of the receiver flash when the “Find Me” function is activated.

If multiple MLG-2s are installed in one application, you can use the “Find Me” function to identify a certain MLG-2.

7.4.3.4 Pushbutton lock

Table 97: Pushbutton lock

Index	Access	Data type	Description
73h	R/W	BOOL	This parameter is used to activate the pushbutton lock for the “Teach” pushbutton on the receiver of the MLG-2. 0 = pushbutton released 1 = pushbutton locked

7.4.3.5 Beam numbering

Table 98: Beam numbering

Index	Access	Data type	Description
74h	R/W	BOOL	This parameter reverses the beam numbering. 0 = beam 1 begins at the connection 1 = beam 1 begins at the head

On delivery, beam 1 is located on the connection side of the MLG-2. You can choose to configure the MLG-2 so that the beam numbering begins at the top.

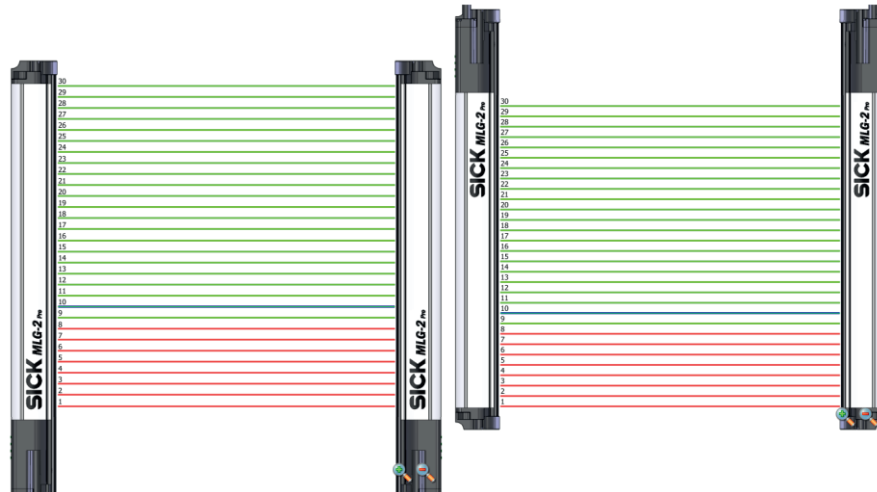

Figure 68: Beam numbering

This might be a good idea, for example, if you mount the MLG-2 with the connections facing upward, but still want to measure height classification from the bottom.



NOTE

Beam numbering has consequences for the beam functions FBB, FBM, LBB, LBM, CBB, CBM, RLC, and on the beam status.

7.4.3.6 Factory settings

Table 99: Factory settings

Index	Access	Data type	Description
75h	R/W	BOOL	This parameter is used to reset the MLG-2 to its factory settings. 0 = no reset 1 = reset to factory settings

You have the option to reset the MLG-2 to the factory settings.

If you reset to factory settings, you will lose all data that has already been configured.



NOTE

- The factory settings are restored as soon as 1 is written.
- The MLG-2 will be reset too. Therefore, the control reports, where necessary, an error that the MLG-2 is no longer available.
- The following applies after resetting to factory settings:
 - No process data such as beam functions or beam status is output.
 - The alignment aid is active.
 - A teach-in is required. All functions become available again only after a successful teach-in process.

7.4.3.7 Cloning upload

Table 100: Cloning upload

Index	Access	Data type	Description
76h	R/W	BOOL	This parameter is used to save the parameters of the MLG-2 to the fieldbus module. 0 = parameters are not saved 1 = parameters are saved A change from 0 to 1 always initiates a save of the parameters to the fieldbus module. If the parameters are to be saved to the fieldbus module again, this index must first be described using 0.

The “Cloning upload” function writes the parameter set configured to the fieldbus module. Following device replacement, the parameters can be loaded back into the light grid from the fieldbus module using the “Cloning download” function.

7.4.3.8 Cloning download

Table 101: Cloning download

Index	Access	Data type	Description
77h	R/W	BOOL	This parameter is used to load the parameters saved in the fieldbus module into the MLG-2. 0 = parameters are not loaded 1 = parameters are loaded A change from 0 to 1 always initiates a loading of the parameters into the MLG-2. If the parameters are to be loaded into the MLG-2 again, this index must first be described using 0.

**NOTE**

The MLG-2 restarts after the download. Existing bus connections or connections with SOPAS ET are interrupted briefly.

Any initial configurations for starting up the MLG-2 which have been set in the control overwrite the values that the cloning download has restored.

7.4.3.9 Cloning status

Table 102: Cloning status

Index	Access	Data type	Description
78h	R	ENUM8	This parameter is used to read the status of the “Cloning” function. 0 = LOCKED 1 = EMPTY 2 = VALID 3 = ACTIVE

The cloning status shows the status of the stored parameters in the fieldbus module

- LOCKED: Uploading and downloading not possible.
- EMPTY: No valid set of parameters available. Uploading parameters is the only option.
- VALID: A valid set of parameters is available in the fieldbus module. Parameters can be uploaded or downloaded.
- ACTIVE: An upload or download is currently active.

7.4.4 Parameters with system information

7.4.4.1 Device name

Table 103: Device name

Index	Access	Data type	Description
80h	R	STRG (18)	This parameter contains the device name, MLG-2 ProNet.

7.4.4.2 Manufacturer name

Table 104: Manufacturer name

Index	Access	Data type	Description
81h	R	STRG (32)	This parameter contains the manufacturer's name, SICK AG.

7.4.4.3 Part number

Table 105: Part number

Index	Access	Data type	Description
82h	R	STRG (7)	This parameter contains the part number of the MLG-2.

7.4.4.4 Serial number

Table 106: Serial number

Index	Access	Data type	Description
83h	R	STRG (8)	This parameter contains the serial number of the MLG-2.

7.4.4.5 Product text

Table 107: Product text

Index	Access	Data type	Description
84h	R	STRG (64)	This parameter contains a short description of the MLG-2.

7.4.4.6 Mounting location

Table 108: Mounting location

Index	Access	Data type	Description
85h	R/W	STRG (32)	You can save the mounting location of the MLG-2 in this parameter.

Entering a mounting location makes it easier to identify where the MLG-2 is mounted.

7.4.4.7 Device characteristics and system boundaries

Table 109: Device characteristics

Index	Access	Data type	Description
86h	R	STRUCT 5 × UINT-16	This parameter contains the following MLG-2 device characteristics: Component 1 = number of beams Component 2 = beam separation Component 3 = repeatability Component 4 = minimum presence time Component 5 = response time

- The **beam number** reflects the number of beams from the MLG-2. Depending on the model, the MLG-2 can have between 6 and 510 beams, only 250 beams for the DPV0.
- **Beam separation:** In order to achieve different levels of measurement accuracy, the MLG-2 is available with different beam separations. (see ["Beam separations and monitoring height"](#), page 15).
- The repeat accuracy of a measurement result (**reproducibility**) is the amount of time by which an object detection can differ from a previous or subsequent detection. The reproducibility time is 1 × the scan time.(see ["Scan time"](#), page 17). The reproducibility is output as an integer in µs.
- The **minimum presence time** is the amount of time an object or gap must be in the detection area in order to be detected. The minimum presence time is no more than 2 × the scan time (see ["Scan time"](#), page 17). The minimum presence time is output as an integer in µs.
- The **response time** is the time it takes for an output to react following the detection of an object/gap. The maximum response time is 3 × the scan time plus the transmission time to the outputs (see ["Scan time"](#), page 17). The response time is output as an integer in µs.

7.4.4.8 Hardware revision

Table 110: Hardware revision

Index	Access	Data type	Description
87h	R	STRG (4)	This parameter contains the revision status of the hardware.

7.4.4.9 Firmware version

Table 111: Firmware version

Index	Access	Data type	Description
88h	R	STRG (12)	This parameter contains the version of the firmware.

The version of firmware in its delivery state can be found on the type label.

7.4.5 Beam evaluation

7.4.5.1 Zone measuring

The beams of the MLG-2 can be divided into four zones. Each zone can be assigned one beam function or application. Zones and beam functions are assigned using the outputs. The functions NBB Zone n, LBB Zone n, FBB Zone n, CBB Zone n and NCBB Zone n are available for each zone (n = 1, 2, 3 or 4).

For additional information, see ["Zone measuring" function](#), page 120

Table 112: Zone measuring

Index	Access	Data type	Description
90h	R/W	UINT-16	Zone 1 First Beam: Sets lower zone boundary for Zone 1
91h	R/W	UINT-16	Zone 1 Last Beam: Sets upper zone boundary for Zone 1
92h	R/W	UINT-16	Zone 2 First Beam: Sets lower zone boundary for Zone 2
93h	R/W	UINT-16	Zone 2 Last Beam: Sets upper zone boundary for Zone 2
94h	R/W	UINT-16	Zone 3 First Beam: Sets lower zone boundary for Zone 3
95h	R/W	UINT-16	Zone 3 Last Beam: Sets upper zone boundary for Zone 3
96h	R/W	UINT-16	Zone 4 First Beam: Sets lower zone boundary for Zone 4
97h	R/W	UINT-16	Zone 4 Last Beam: Sets upper zone boundary for Zone 4

7.4.5.2 Cross beam measuring

Table 113: Cross beam measuring

Index	Access	Data type	Description
98h	R/W	BOOL	<p>If the “Cross beam function” option is activated via the “61h performance options” object, you can use this object to choose between the “Cross beam measuring” and “Cross beam switching” options.</p> <p>0 = “Cross beam measuring” function deactivated. “Cross beam switching” function is active.</p> <p>1 = “Cross beam measuring” function activated.</p>

7.4.5.3 BBH and LBH evaluation modes

For a description of the “Blocked Beams Hold (BBH)” evaluation mode, see [“Blocked Beams Hold \(BBH\)” evaluation mode](#), page 131

For a description of the “Lost Beams Hold (LBH)” evaluation mode, see [“Lost Beams Hold \(LBH\)” evaluation mode](#), page 132

Table 114: Evaluation mode

Index	Access	Data type	Description
99h	R/W	ENUM-8	<p>This parameter is used to select an evaluation mode.</p> <p>0: OFF, no BBH mode or LBH mode active</p> <p>1: BBH mode active</p> <p>2: LBH mode active</p>

Index	Access	Data type	Description
9Ah	R/W	STRUCT (28 x UINT-8)	<p>This parameter is used to activate and deactivate the beam functions that will be used for the evaluation mode.</p> <p>Byte 0: NBB Byte 1: NBM Byte 2: FBB Byte 3: FBM Byte 4: LBB Byte 5: LBM Byte 6: NCBB/CBB Byte 7: NCBM/CBM Byte 8: ODI Byte 9: IDI Byte 10: RLC Byte 11: BS Byte 12: NBB Zone 1 Byte 13: NBB Zone 2 Byte 14: NBB Zone 3 Byte 15: NBB Zone 4 Byte 16: FBB Zone 1 Byte 17: FBB Zone 2 Byte 18: FBB Zone 3 Byte 19: FBB Zone 4 Byte 20: LBB Zone 1 Byte 21: LBB Zone 2 Byte 22: LBB Zone 3 Byte 23: LBB Zone 4 Byte 24: NCBB/CBB Zone 1 Byte 25: NCBB/CBB Zone 2 Byte 26: NCBB/CBB Zone 3 Byte 27: NCBB/CBB Zone 4</p>

8 Configuration with SOPAS ET

8.1 Preparation

8.1.1 Installing the software

SOPAS ET 3.0 or higher is required for configuring the MLG-2.

The latest version of SOPAS ET can be found at www.sick.de > Search > SOPAS.

Observe the system requirements for SOPAS ET. These are mentioned on the download website:

- ▶ Run the setup.exe from the download website.
- ▶ Follow the instructions in the Setup wizard.

Ethernet settings

The MLG-2 is shipped with the following IP network configuration:

- Static IP address. DHCP deactivated.
- IP address: 192.168.200.100
- Subnet mask: 255.255.255.0

You can change the IP network configuration in SOPAS ET.

If you would like the MLG-2 to acquire an IP address from a DHCP server, DHCP must be activated. If the MLG-2 is unable to locate a DHCP server, the MLG-2 will use the IP address 192.168.200.100.

Starting the software

Use the application **SICK > SOPAS Engineering Tool > Sopas** from the Start menu to configure the MLG-2.

8.1.2 Device selection

A SOPAS Device Description (SDD) is required in order to configure the MLG-2.

Detecting a connected device

When an MLG-2 is connected to the PC/notebook via Ethernet, the SDD can be loaded directly from the device and SOPAS ET will detect the MLG-2 type automatically.

Configuring a device offline

Alternatively, you can select the MLG-2 type offline using the device selection wizard. To do this, you must load the SDD from the Internet. This requires an Internet connection.

You can either enter the type code of the MLG-2 directly into the device selection wizard or define the following criteria:

- Monitoring height
- Maximum sensing range
- Interface (number and type of inputs and outputs)
- Size of the smallest object in the application

Once you have selected the desired MLG-2, the configuration interface/wizard starts up.



NOTE

If you configure a device offline, you must then connect the PC to the MLG-2 and download the MLG-2 configuration.

8.2 SOPAS ET interface

At the top of the interface, you can change the MLG-2 type, the operating mode, and the user level.



Figure 69: Device selection, operating mode and user level

Device selection

If you carry out the configuration offline (without a connected MLG-2), you can change the MLG-2 type via the button shown on the left.

If the MLG-2 is online, the type code of the MLG-2 will be displayed.

Operating modes

The MLG-2 has the following operating modes:

- **Standard**
For normal measuring tasks involving opaque objects (recommended for the majority of applications)
- **Transparent**
For transparent objects, e.g., made of glass, PET, etc.
- **Dust- and sunlight-resistant**
For applications when there is a large amount of dust in the environment or a high level of solar radiation



NOTE

When the operating mode is changed, a new teach-in process must be performed.

The choice of operating mode affects the performance options.

User level

The configuration is divided into two user levels.

The user level **EASY** shows only the parameters that are absolutely necessary and is a quick way of completing the task. This level is automatically activated when SOPAS ET starts up.

For experienced users or those with more complex requirements, the user level **EXPERT** allows you to configure all of the parameters.

Three-part interface

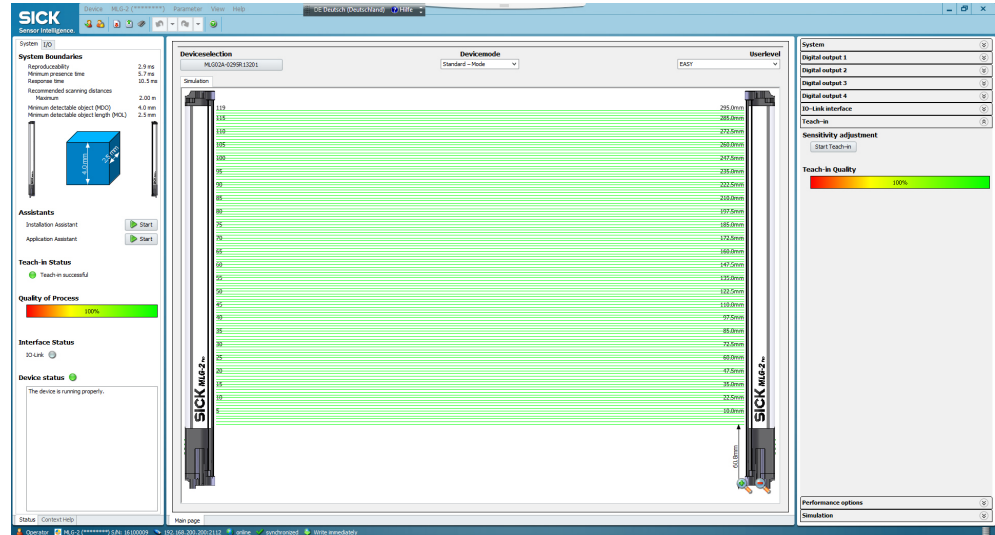

Figure 70: SOPAS ET interface

The **left-hand side** of the graphical interface provides information on the system boundaries, the status and the interfaces of the connected MLG-2.

The **central area** shows a simulation of the light grid and its beams.

The **right-hand side** of the interface lists the available options in expandable menus.

8.2.1 System boundaries and status

System boundaries

System boundaries

Reproduceability	0.7 ms
Minimum presence time	1.4 ms
Response time	3.6 ms
Max. recommended scanning distance	5.0 m
Minimum detectable object (MDO)	14 mm
Minimum detectable object length (MOL)	7 mm

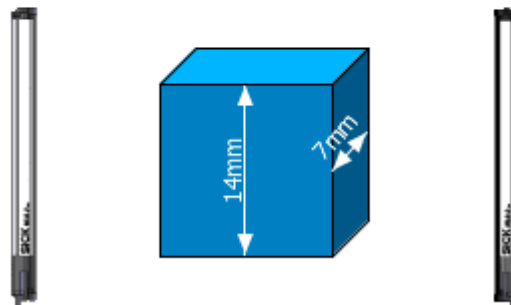

Figure 71: Display of the system boundaries

Under “System boundaries”, SOPAS ET displays the reproducibility, minimum presence time, and response time (see "Scan time", page 17).

SOPAS ET displays the maximum recommended sensing range with which the MLG-2 can be safely operated.

The minimum detectable object (MDO) and the minimum detectable object length (MOL) are specified in millimeters as well as shown graphically.

The system boundaries are largely dependent on the configured performance options (see "Performance options", page 125).

Wizards

Wizards



Figure 72: Wizards

You can start the Installation Wizard or Application Wizard under **Wizards**.

- The **Installation Wizard** helps you to align the MLG-2 and carry out the teach-in process.
- The **Application Wizard** helps you to configure the settings for the outputs. Only the necessary adjustments for the MLG-2 are offered, according to the choice of application.

Recommendation

Use this wizard for the initial configuration of a device. The separate adjustments available in the main interface allow the user to make specific changes to the configuration.

Teach-in status

If a teach-in becomes necessary because of a change to a parameter, the LED symbol will light red, indicating **teach-in required**.

Process quality

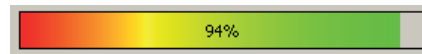

Figure 73: Display of the process quality

SOPAS ET shows the process quality as a percentage and as a colored bar.

Interface status

SOPAS ET displays the communication status via the respective interface.

- Green = communication active
- Gray = communication not active

Device status

SOPAS ET displays the device status via a colored indicator and in the form of plain text:

- Green = MLG-2 functions reliably
- Yellow = warning pending
- Red = error has occurred

8.2.2 Basic functions and status of the output

Basic functions

Under **Basic functions**, you will find the following information:

- The current values for the beam functions (see "Beam functions", page 138)
- The current values for the run-length code

System
I/O

Basic Functions

NBB = 0 (Number of Beams Blocked)
 NBM = 60 (Number of Beams Made)
 FBB = n° - (First Beam Blocked)
 FBM = n° 1 (First Beam Made)
 LBB = - (Last Beam Blocked)
 LBM = 60 (Last Beam Made)
 NCBB = 0 (Number of consecutive Beams Blocked)
 NCBM = 60 (Number of consecutive Beams Made)
 CBB = n° - (Central Beam Blocked)
 CBM = n° 30 (Central Beam Made)
 ODI = 0 (Outside Dimension)
 IDI = 0 (Inside Dimension)

RLC-Values (Run Length Code)

RLC1	RLC2	RLC3	RLC4	RLC5	RLC6	RLC7	RLC8
60	0	0	0	0	0	0	0
RLC9	RLC10	RLC11	RLC12	RLC13	RLC14	RLC15	RLC16
0	0	0	0	0	0	0	0

Status In-/Outputs

Q1 NBB ≥ 1

Figure 74: Basic functions and status of the output

Status inputs/outputs

Under Status inputs/outputs, SOPAS ET shows the status of the switching output. Next to the indicator, you will find the function configured for the output.

8.2.3 Representation of the detection area

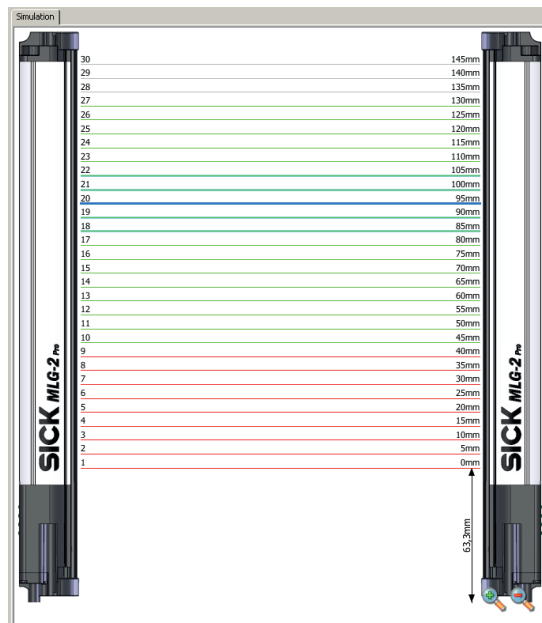

Figure 75: Detection area – Simulation

The **central** area of the SOPAS ET interface shows a simulation of the MLG-2 and its beams:

- Green = Made beams
- Red = Blocked beams
- Gray = Blanked beams
- Blue = Beams selected with the mouse
- Turquoise = Configured tolerance

You can use the context menu to perform certain actions with the selected beams.

Context menu – Combining beams into zones

- ▶ Select multiple consecutive beams.
- ▶ In the context menu, select the command **Combine to a zone > Zone X**.

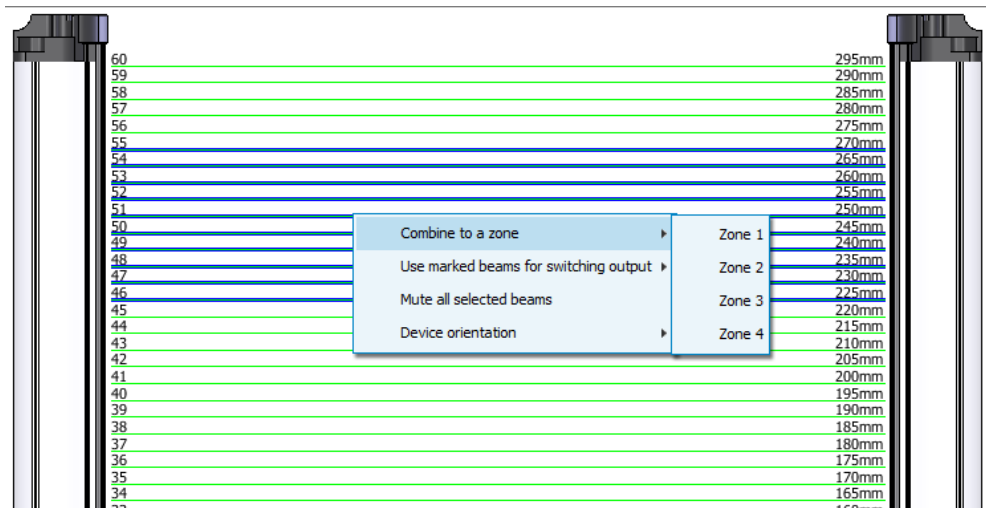

Figure 76: Combining beams into zones

First, configure a zone in the beam window. In the example, beams 13 and 14 are combined into one zone. Next, assign an application and a zone to the desired output (see ["Zone measuring" function](#), page 120).

Context menu – Using beams for object recognition

- ▶ Select several beams (by pressing the Ctrl key).
- ▶ In the context menu, select the command **Assign selected beams to a switching output > For object recognition > Use Qx**.

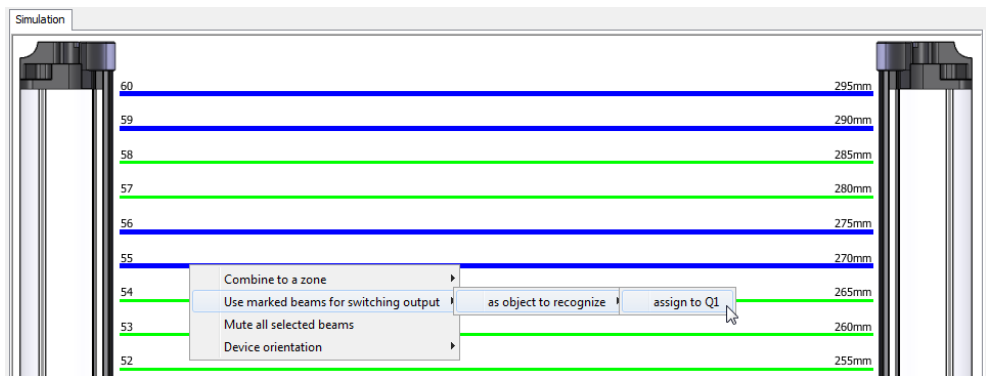

Figure 77: Using beams for object recognition

In the example, beams 10 and 11 and beams 14 and 15 are assigned to output Q1. If these beams are blocked, output Q1 switches. The object size may vary positively or negatively by the number of tolerance beams set (see "Object recognition", page 108).

Context menu – Using beams for height classification

- ▶ Select a beam.
- ▶ In the context menu, select the command **Assign selected beams to a switching output > As maximum height > Use Qx.**

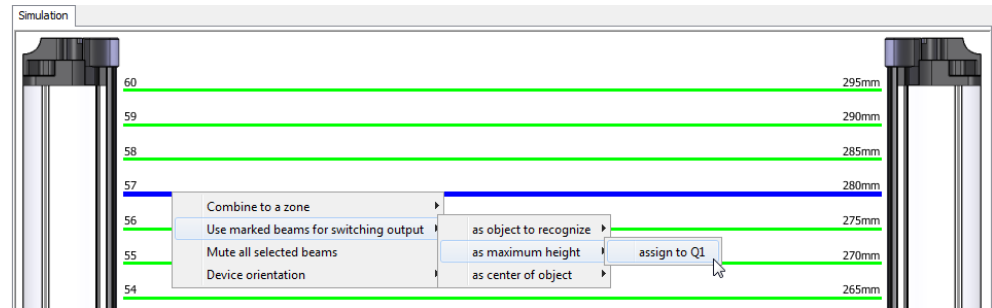

Figure 78: Using beams for height classification

In the example, beam 12 is assigned to output Q1. If the last beam blocked is greater than or equal to beam 12, output Q1 switches.

Context menu – Using beams to classify the object position

- ▶ Select a beam.
- ▶ In the context menu, select the command **Assign selected beams to a switching output > As center of object > Use Qx.**

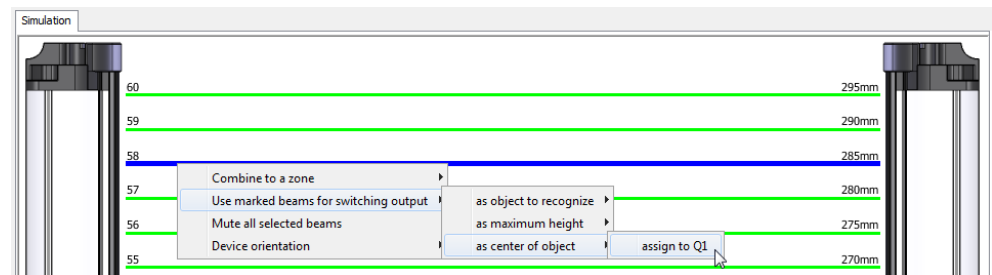

Figure 79: Using beams to classify the object position

In the example, beam 13 is assigned to output Q1. If beam 13 is detected as the center of the object (e.g., beams 12, 13, 14 or beams 11, 12, 13, 14, 15 are blocked), output Q1 switches.

Context menu – Blanking beams

- ▶ Select one or more beams (press the Ctrl key to select several beams).
- ▶ In the context menu, select the command **Blank all selected beams.**

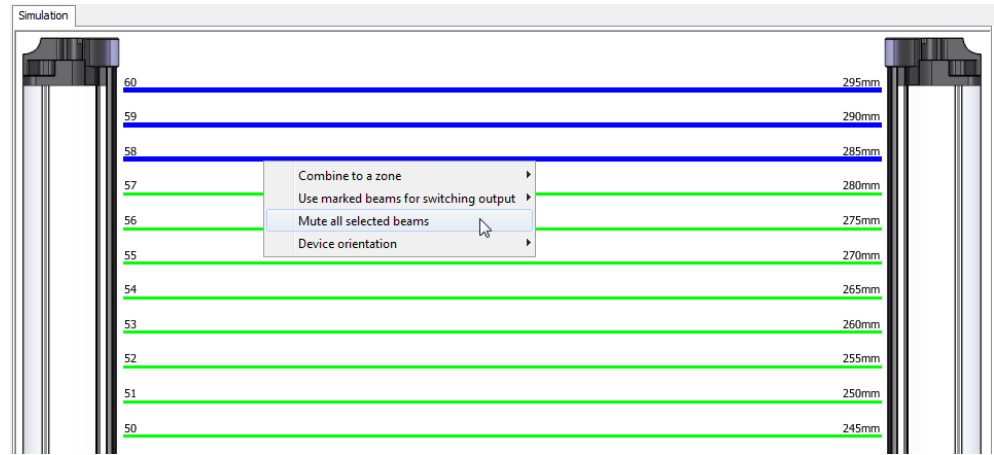

Figure 80: Blanking beams

In the example, beams 13, 14, and 15 are selected and blanked. They are shown in gray and excluded from the measurement.

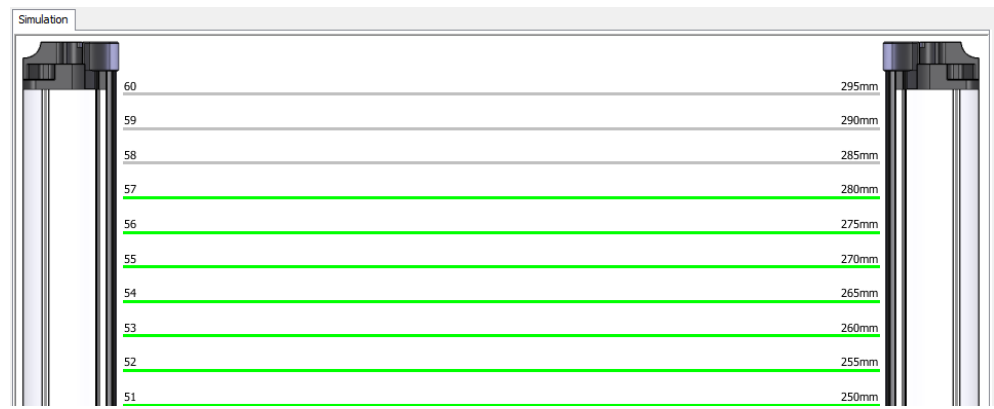

Figure 81: Blanked beams

Context menu - Rotating the image of the MLG-2

The image of the MLG-2 can be adapted for particular applications.

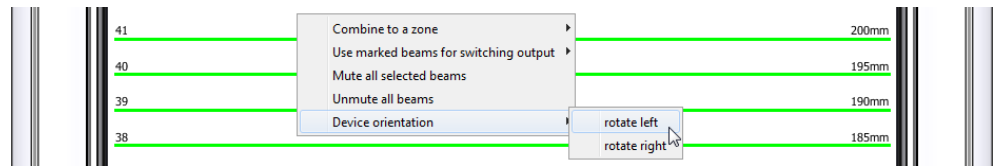

Figure 82: Rotating the image of the MLG-2

- In the context menu, select the command **Device orientation** > **rotate left** or > **rotate right**.

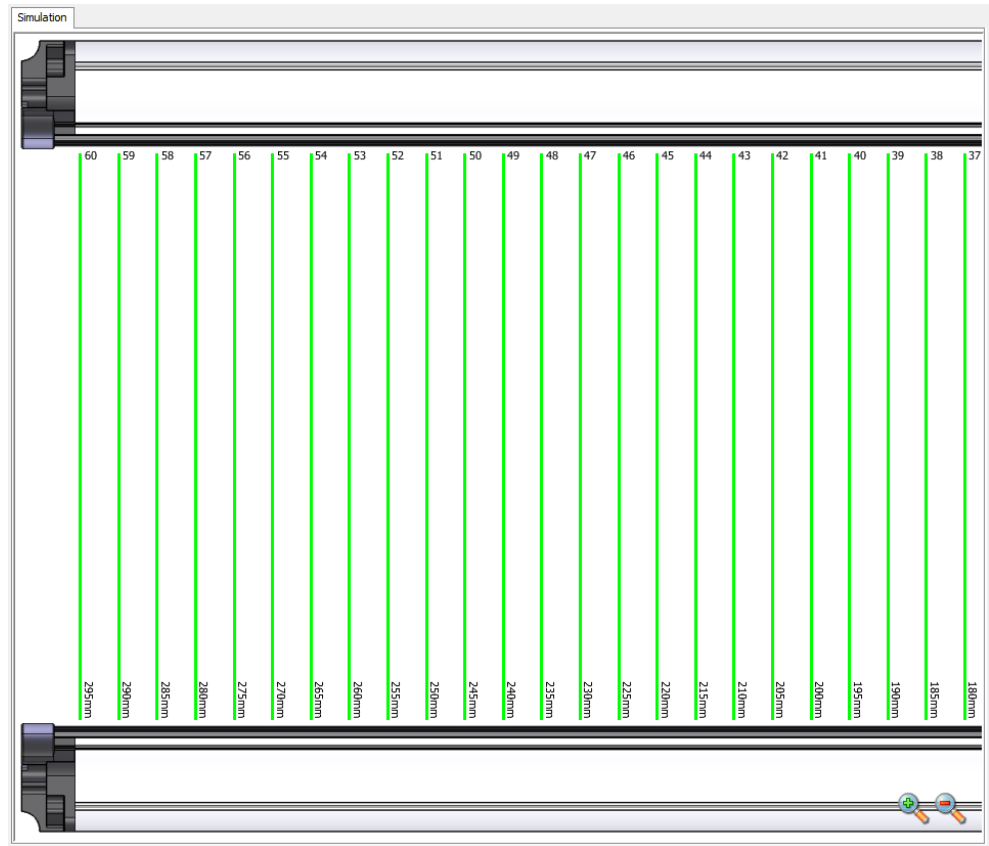

Figure 83: Image of the MLG-2 rotated

Repeat this process until you are happy with how the image appears.

8.2.4 Expandable menus

The expandable menus on the right-hand side help you to configure the MLG-2.



Figure 84: Expandable menus for configuration

- ▶ Click on the double arrow to open the expandable menu.
- ▶ To close the expandable menu, click the double arrow – which is now inverted – again.

Configuring the outputs

When the MLG-2 is online, the configuration of the outputs is written to the device and transferred immediately to the status indicator for the outputs. You will see the response of the outputs immediately in the status indicator.

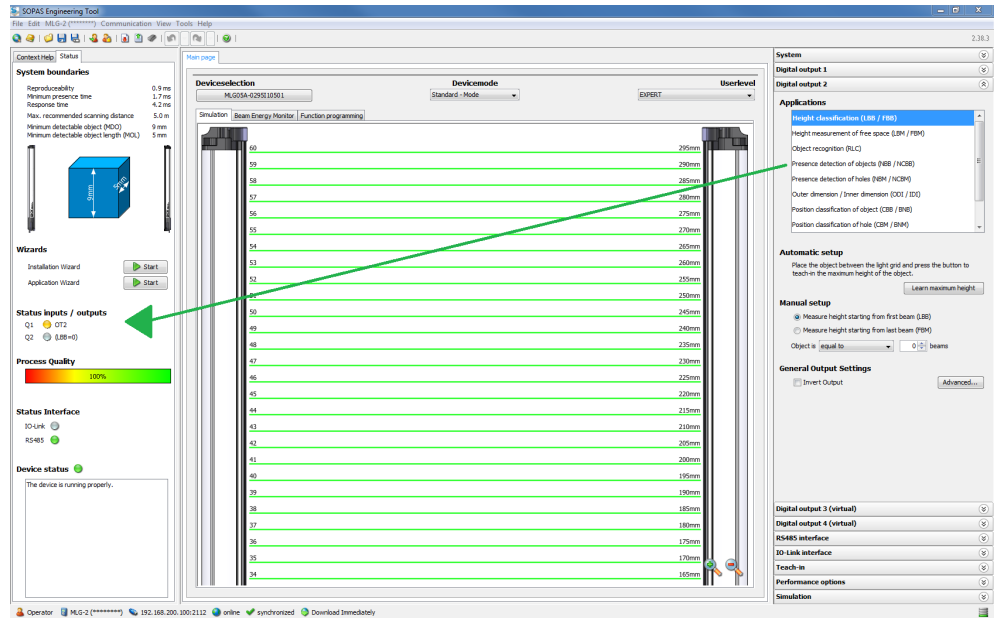

Figure 85: Effect of the output configuration on the status indicator

Configuring the performance options

When the MLG-2 is online, the performance options are written to the device and displayed immediately in the system boundaries (it may be necessary to perform a teach-in process after changing the performance options).

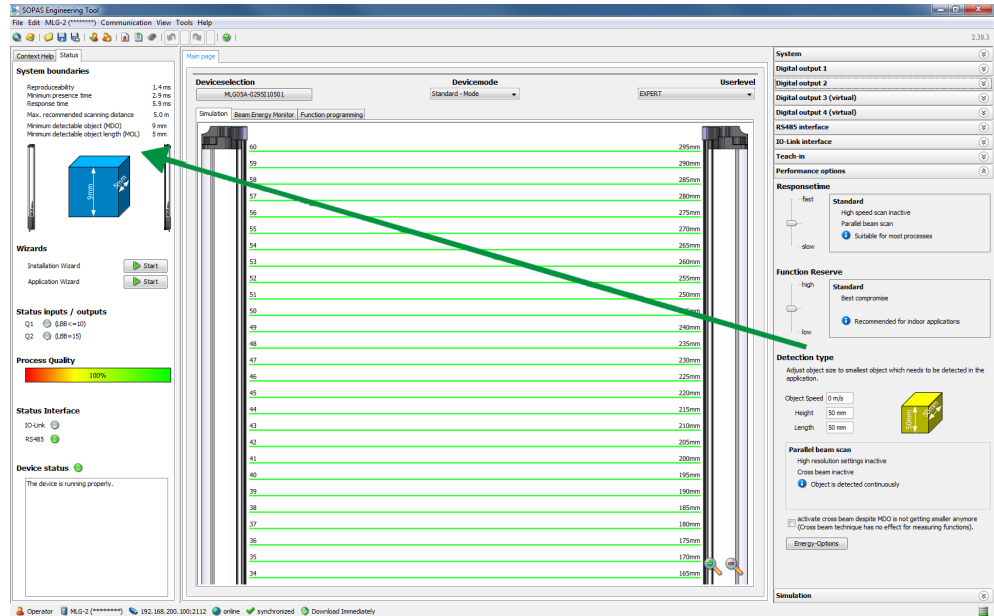

Figure 86: Effects of the performance options on the system boundaries

8.3 System settings

8.3.1 System settings for the user levels EASY and EXPERT

Identification

The **Identification** area contains the following information:

- Type code
- Optional: Current type code
This field is only displayed when the current system constellation is different from the original one delivered.
The MLG-2 consists of a receiver, fieldbus module and sender. These components are defined by the type code in the receiver. If a different field bus module or/and another sender is being used, the type code resulting from this is shown as the **current type code**.
- Part number
- Manufacturer
- Serial number
- Individual device name
You can enter a description of the MLG-2's application or usage here.

Version

The **Version** area contains the following information:

- Hardware version
- Software version
- Fieldbus module hardware version
- Fieldbus module software version

Pushbutton lock

You can use the pushbutton lock to set two options for the teach-in button on the device:

- Released: A teach-in process can be triggered using the button.
- Locked: The teach-in button is locked to prevent inadvertent actuation, for example.

8.3.2 System settings for the EXPERT user level

I/O configuration

I/O No.	Pin No.	Pin configuration
1	4	OUTPUT
2	6	INPUT

Figure 87: I/O configuration

You can view the MLG-2's output and the pin on the connection in this figure.

Beam numbering

On delivery, beam 1 is located on the connection side of the MLG-2. You can choose to configure the MLG-2 so that the beam numbering begins at the top.

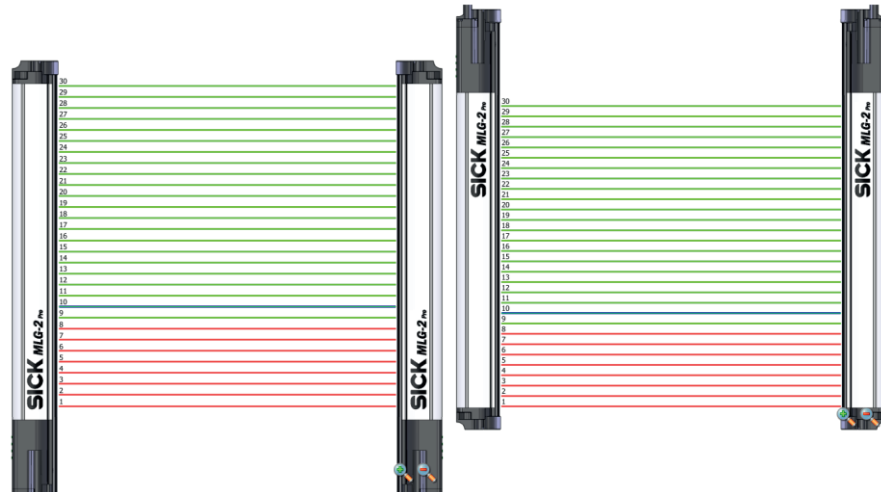

Figure 88: Beam numbering

This might be a good idea, for example, if you mount the MLG-2 with the connections facing upward, but still want to measure height classification from the bottom.



NOTE

Beam numbering has consequences for the beam functions FBB, FBM, LBB, LBM, CBB, CBM, RLC, and on the beam status.



NOTE

This affects measuring functions that have already been configured. In the example, a height classification is configured with the 10th beam (blue).

Pushbutton lock

You can use the pushbutton lock to set two options for the teach-in button on the device:

- Released: A teach-in process can be triggered using the button.
- Locked: The teach-in button is locked to prevent inadvertent actuation, for example.

Reset

You have the option to reset the MLG-2 to the factory settings.

If you reset to factory settings, you will lose all data that has already been configured.



NOTE

- The factory settings are restored as soon as 1 is written.
- The MLG-2 will be reset too. Therefore, the control reports, where necessary, an error that the MLG-2 is no longer available.
- The following applies after resetting to factory settings:
 - No process data such as beam functions or beam status is output.
 - The alignment aid is active.
 - A teach-in is required. All functions become available again only after a successful teach-in process.

The **Reset** command sets the MLG-2 back to the **factory settings**.

Ethernet

In the **Ethernet** area, you make communication interface TCP/IP settings for SOPAS ET or the integrated web server.

First of all, select the **DHCP** or **Static** option from the **Addressing mode** field.

With the **Static** addressing mode, you can change the **IP address**, the **subnet mask**, and the **gateway address**. The **MAC address** is also displayed.



NOTE

Only make changes if you know your network very well and you know what effect the changes will have on the settings!

8.3.3 System settings for PROFIBUS

In the **Address configuration** area, you can enter the **address** in the PROFIBUS. You can enter an address from 1 to 125 for the MLG-2.

Figure 89: Address configuration in SOPAS ET



NOTE

Only make changes if you are extremely familiar with your network, and if you know what effect the changes will have on the settings!

8.4 Measuring and diagnostic functions for switching outputs

A measuring or diagnostic function can be configured for each switching output on the MLG2. If the criteria configured for the function are met, this is signaled on the relevant output.

All measuring functions can be configured manually. The configurable details are shown for the selected measuring function.

For the **height classification** and **object recognition** measuring functions, objects that are actually in the detection area can be defined automatically.

The measuring functions that have been set are shown graphically in the Simulation area and can be edited here using the mouse.

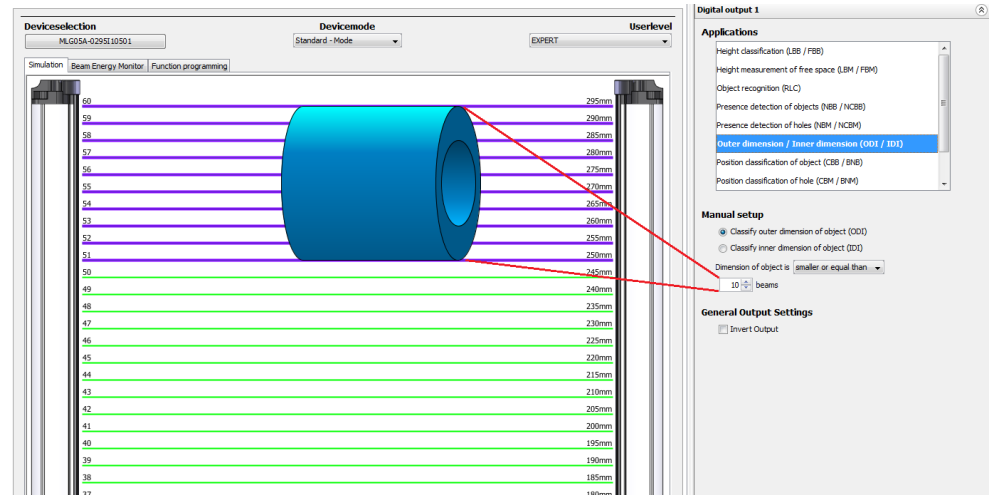

Figure 90: Example representation of the outer dimension

The results of the measuring functions are shown on the status display for the outputs (see "Basic functions and status of the output", page 96).



NOTE

The configuration of the switching outputs is linked to the function programming option (only visible in the **EXPERT** user level). Settings made when configuring the outputs are also shown in the function programming option. If very complex configurations are created for an output in the function programming option, these can no longer be changed in the configuration of the switching outputs.

8.4.1 Height classification

A switching output switches when the measured object corresponds to the configured or defined height.

Automatic configuration

SOPAS ET can teach in the maximum object height automatically.

The output becomes active when an object is larger than the defined object. The device checks, therefore, whether an object exceeds a certain height.

- ▶ Place or hang the object in the detection area of the MLG-2.
- ▶ Click **Teach-in maximum height**.

The measurement is taken from the top or bottom automatically, depending on the alignment of the object.

The algorithm first checks whether the first or last beam is blocked:

- If the first beam is blocked, the height is measured from the bottom.⁵⁾
- If the last beam is blocked, the height is measured from the top.⁵⁾

If both the first and last beams are made or blocked, the optical center of gravity is determined.

- If more beams are blocked on the side of the first beam, the height is measured from the bottom.
- If more beams are blocked on the side of the last beam, the height is measured from the top.

⁵⁾ Applies when light grid is mounted upright with the connection side facing down and beam numbering beginning on the connection side (factory setting).



NOTE

Blocked beams are shown in the simulation in red and made beams are shown in green. The automatically defined object height can be further adjusted afterward.

Manual configuration

- ▶ Select the beam from which the height is to be measured:
 - Height measured from last beam
 - Height measured from first beam
- ▶ Select one of the following settings for the height classification and enter the number of beams n:

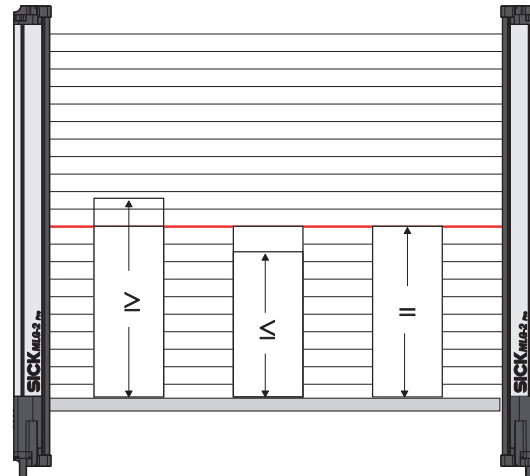

Figure 91: Settings for height classification

- **≥ Object is larger than or equal to n beams:**
The output becomes active when an object covers the beam defined as the top beam or reaches beyond this beam.
- **≤ Object is smaller than or equal to n beams:**
The output becomes active when an object covers the beam defined as the top beam or falls short of this beam.
- **= Object is equal to n beams:**
The output becomes active when an object is the exact same size as the beam defined as the top beam.

The beam that has been set is shown in blue in the **Simulation** area. It can be moved using the mouse.

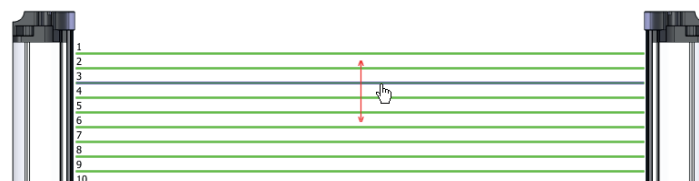

Figure 92: Setting the height with the mouse

Zone selection

For additional information, see "["Zone measuring" function](#)", page 120 .

Output settings

General options for switching outputs see "[Advanced settings for the outputs](#)", page 119.

8.4.2 Object recognition

The MLG-2 memorizes the pattern of configured or defined objects. The output switches when the MLG-2 recognizes objects or gaps with the configured size.



NOTE

The maximum number of beam status changes may not exceed the half number of beams, but at least 16 and a maximum of 120.

Defining an object automatically

You can define the object to be detected automatically.

- ▶ Place the object(s) in the detection area of the MLG-2.
- ▶ Then click **Teach-in object**.

The size of the objects and the size of the gaps between the objects are shown in the simulation. The sizes can be further adjusted afterward.

Manual configuration

In the simulation, you can determine the size of the object(s) by selecting corresponding beams.



Figure 93: Beams highlighted in color in the simulation

The blue beams in the Simulation area represent the object; the beams shown in turquoise are the tolerance.

Settings for automatic and manual configuration

- ▶ Select one of the following settings for object recognition:
 - **Static**
An object will be recognized if it is in the exact location in which the object was configured or automatically defined. This also applies to multiple objects, e.g., the feet of a pallet.

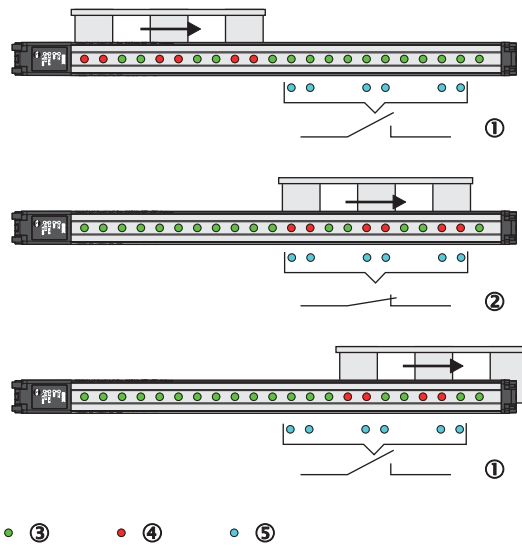

Figure 94: Object recognition, static

- ① Output not switched
- ② Output switched
- ③ Made beam
- ④ Blocked beam
- ⑤ Configured beam

• **Dynamic**

An object will be recognized at every point in the detection area. The object is allowed to move within the detection area. This also applies to multiple objects, e.g., the feet of a pallet.

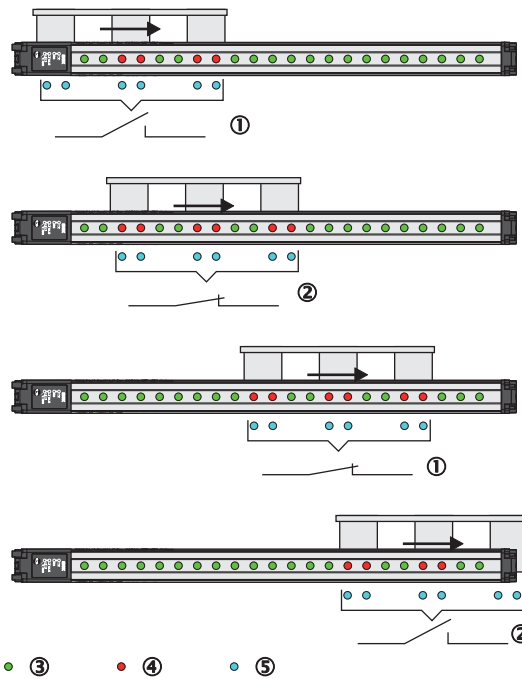

Figure 95: Object recognition, dynamic

- ① Output not switched
- ② Output switched
- ③ Made beam

- ④ Blocked beam
- ⑤ Configured beam

- **Tolerance**

Without a tolerance, objects will only be recognized if they block exactly the configured number of beams. If you enter a tolerance, the object size can vary positively or negatively by the number of tolerance beams.

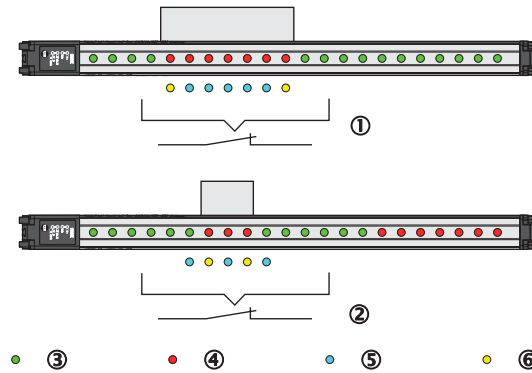

Figure 96: Object recognition with tolerance

- ① Positive tolerance
- ② Negative tolerance
- ③ Made beam
- ④ Blocked beam
- ⑤ Configured beam
- ⑥ Tolerated beams

When a tolerance is set, it is shown in the simulation with turquoise beams.

Output settings

General options for switching outputs see "[Advanced settings for the outputs](#)", page 119.

8.4.3 Object detection/object width

A switching output switches when an object of a particular size is present in the detection area.

A corresponding setting is configured which requires a certain number of beams or a certain number of **consecutive** beams to be blocked.

The number of beams is configured in the settings or configured graphically in the **Simulation** area using the mouse.

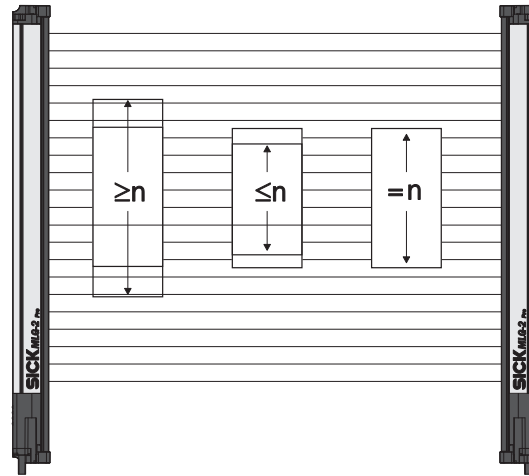

Figure 97: Object detection/object width

- ▶ Select one of the following n settings for the object detection/object width and enter the number of n beams:
 - **≥n object is larger than or equal to n beams:**
The output becomes active when the configured number of beams or more has been blocked.
 - **≤n object is smaller than or equal to n beams:**
The output becomes active when the configured number of beams or less has been blocked.
 - **= n object is equal to n beams:**
The output becomes active if the exact number of configured beams is blocked.

The object size that has been set is shown in the **Simulation** area. It can be changed using the mouse.

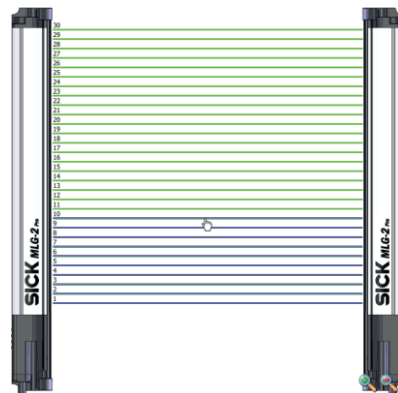

Figure 98: Setting the object size with the mouse

Only take into account consecutive beams:

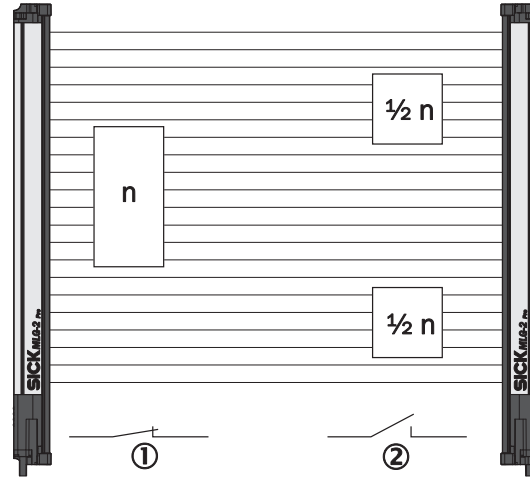

Figure 99: Object detection of consecutive objects

- ① Criterion met
- ② Criterion not met

The output becomes active when consecutive beams are covered. If this option is not activated, the number of blocked beams can also be made up of several objects or objects with gaps.

Zone selection

For additional information, see ["Zone measuring" function](#), page 120 .

Output settings

General options for switching outputs see ["Advanced settings for the outputs"](#), page 119.

8.4.4 Hole detection/hole size

A switching output switches when an object with a hole of a particular size is present in the detection area.

A corresponding setting is configured which requires a certain number of beams or a certain number of **consecutive** beams to be made.

The number of beams is configured in the settings.

The measuring function can be used for **hole detection**, e.g., in a metal sheet, by configuring a number of made beams ≥ 1

- ▶ Select one of the following settings for the hole detection and enter the number of n beams:

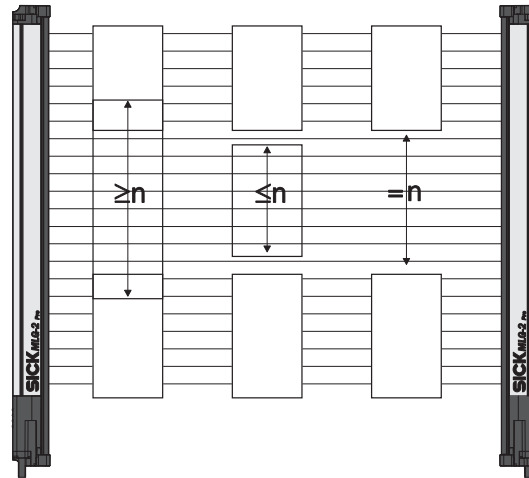

Figure 100: Hole detection/hole size

- **$\geq n$ hole is larger than or equal to n beams:**
The output becomes active when the configured number of beams or more are made.
- **$\leq n$ hole is smaller than or equal to n beams:**
The output becomes active when the configured number of beams or fewer are made.
- **$= n$ hole is equal to n beams:**
The output becomes active if the exact number of configured beams are made.

The hole size that has been set is shown in the **Simulation** area. It can be changed using the mouse.

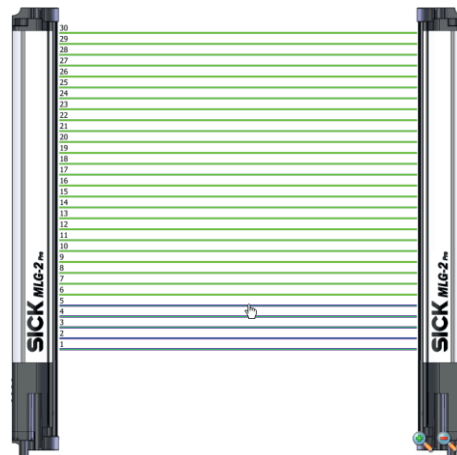

Figure 101: Setting the hole size with the mouse

Only take into account consecutive beams:

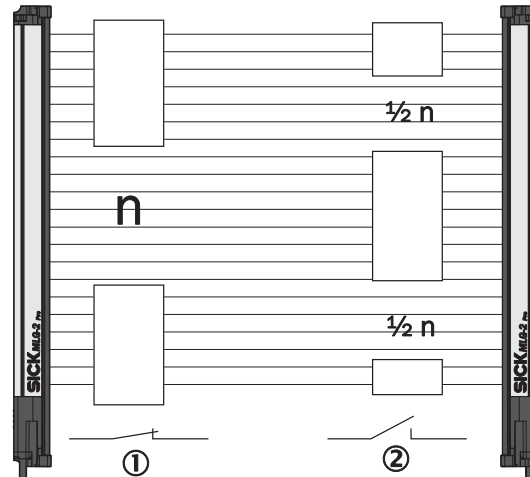

Figure 102: Detection of consecutive beams

- ① Criterion met
- ② Criterion not met

The output becomes active when the beams are made through a single hole. If this option is not activated, the number of made beams can also be made up of several gaps.

Output settings

General options for switching outputs [see "Advanced settings for the outputs", page 119.](#)

8.4.5 Outside/inside dimension

A switching output switches when an object with a particular outside or inside dimension is detected.



NOTE

If there are several objects in the detection area, the largest object determines the measured value.

The following settings are possible for measuring the outside or inside dimension:

- Configure whether you want to measure the **outside dimension** or **inside dimension**.

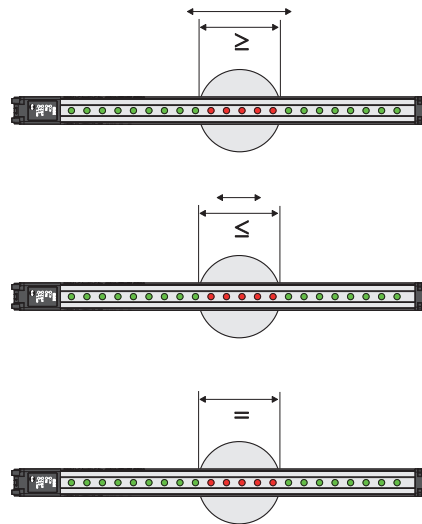

Figure 103: Measurement of the outside dimension

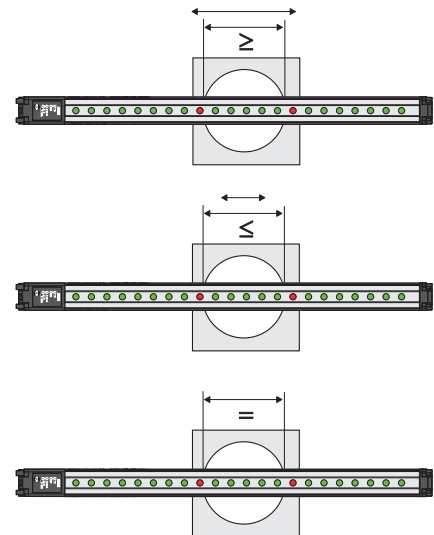

Figure 104: Measurement of the inside dimension

- ▶ Select one of the following settings:
 - **\geq Object diameter is greater than or equal to n beams:**
The output becomes active if the configured number of beams or more were blocked/made.
 - **\leq Object diameter is less than or equal to n beams:**
The output becomes active if the configured number of beams or less were blocked/made.
 - **= Object dimension is equal to n beams:**
The output becomes active if precisely the configured number of beams was blocked/made.

A particular number of beams is configured for the outside or inside dimension in the settings. The object size is shown in the **Simulation** area and can be changed here using the mouse.

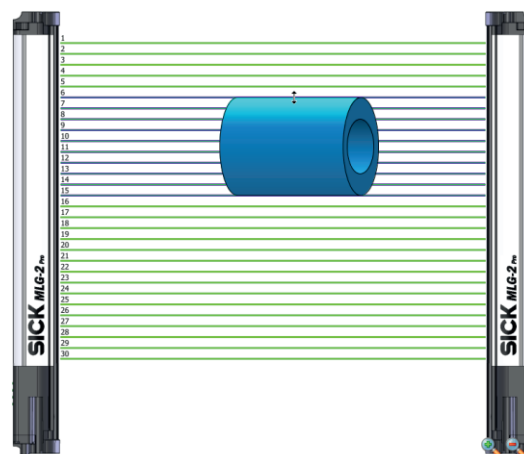

Figure 105: Setting the outside dimension with the mouse

Output settings

General options for switching outputs see "Advanced settings for the outputs", page 119.

8.4.6 Classification of an object position

A switching output switches when the center of an object is located exactly on the beam configured as the position.



NOTE

If there are several objects in the detection area, the central beam of the largest object determines the object position.

A particular beam is configured for the classification of the object position in the settings.

► Select one of the following settings:

- The object center is greater than or equal to the position of beam number n.

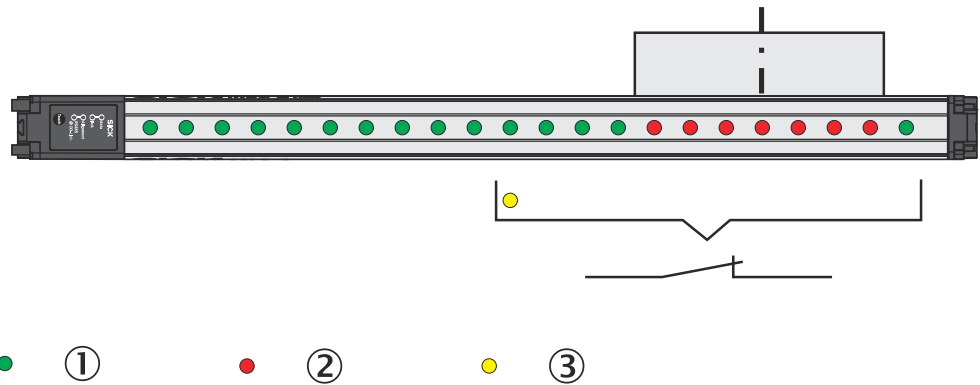

Figure 106: Classification of the object position – object center is greater than or equal to n beam

- ① Made beam
- ② Blocked beam
- ③ Configured beam

- The object center is less than or equal to the position of beam number n.

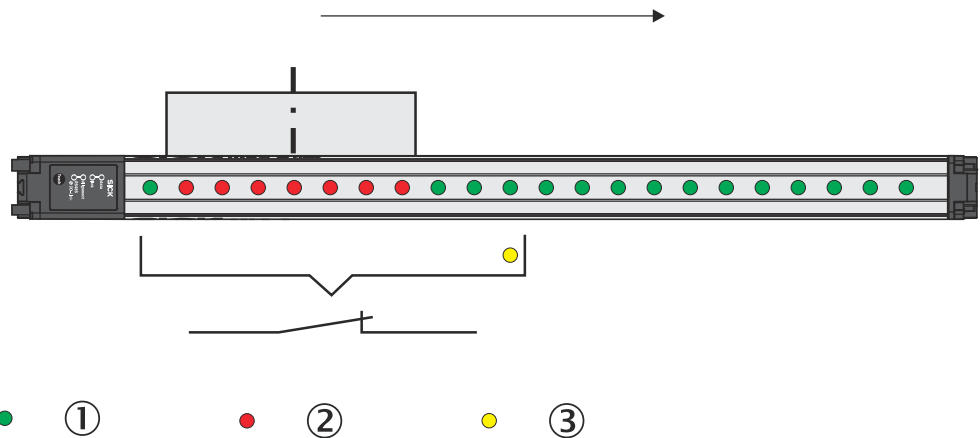

Figure 107: Classification of the object position – object center is smaller than or equal to n beam

- ① Made beam
- ② Blocked beam
- ③ Configured beam

- The object center is equal to the position of beam number n.

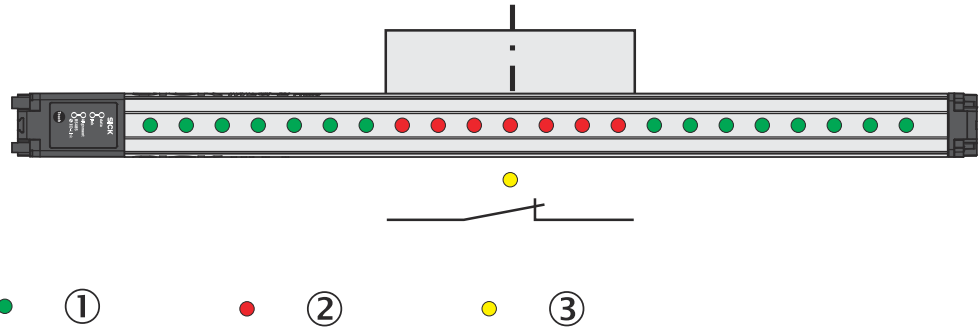

Figure 108: Classification of the object position – object center is equal to n beam

- ① Made beam
- ② Blocked beam
- ③ Configured beam

General options for switching outputs see "Advanced settings for the outputs", page 119.

The object position that has been set is shown in the **Simulation** area. It can be changed using the mouse.

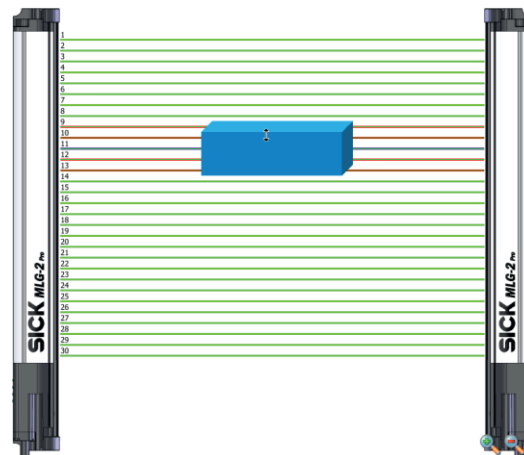

Figure 109: Setting the object position with the mouse

Zone selection

For additional information, see "Zone measuring" function", page 120 .

8.4.7 Classification of a hole position

A switching output switches when the center of a hole is located on the beam configured as the hole position.



NOTE

If there are several holes in the detection area, the central beam of the largest hole determines the hole position.

A particular beam is configured for the classification of a hole position in the settings.

- ▶ In addition, select one of the following settings:
 - **The hole center is greater than or equal to the position of beam number n.**
The number of the beam located in the center of the hole is greater than or equal to the number of the configured beam.

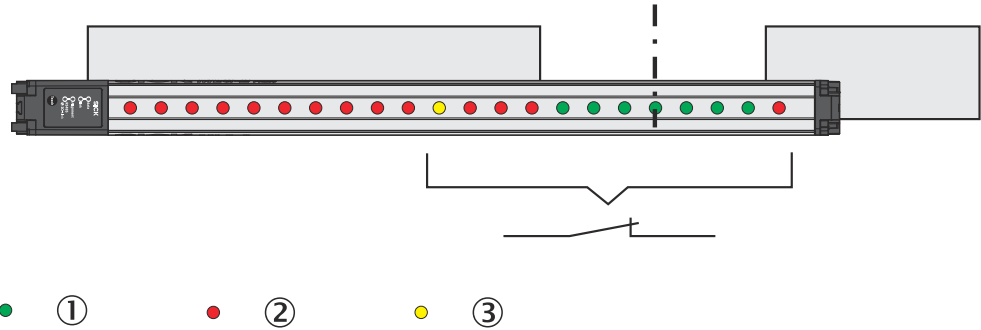

Figure 110: Classification of the hole position – larger than or equal to hole center

- ① Made beam
- ② Blocked beam
- ③ Configured beam

- **The hole center is smaller than or equal to the position of beam number n.**
The number of the beam located in the center of the hole is smaller than or equal to the number of the configured beam.

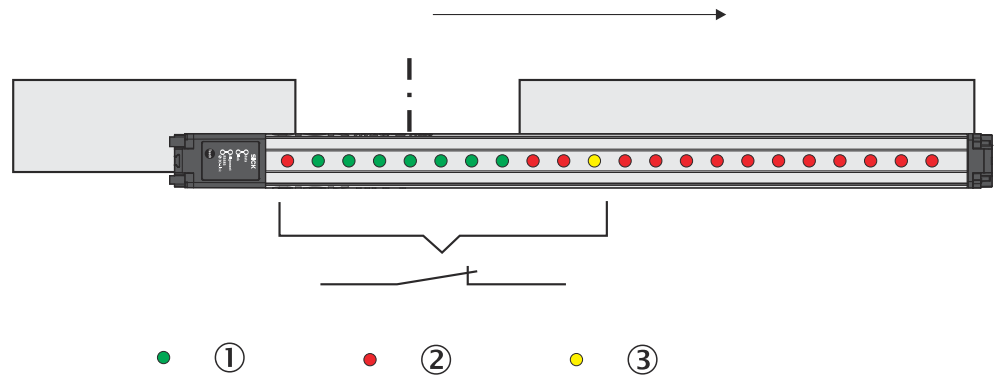

Figure 111: Classification of the hole position – smaller than or equal to hole center

- ① Made beam
- ② Blocked beam
- ③ Configured beam

- **The hole center is equal to the position of beam number n.**
The center of the hole is located exactly at the configured beam.

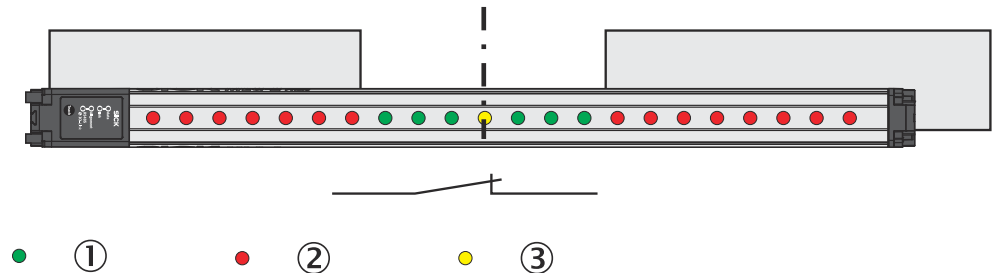

Figure 112: Classification of the hole position – equal to hole center

- ① Made beam
- ② Blocked beam
- ③ Configured beam

The hole position that has been set is shown in the **Simulation** area. It can be changed using the mouse.

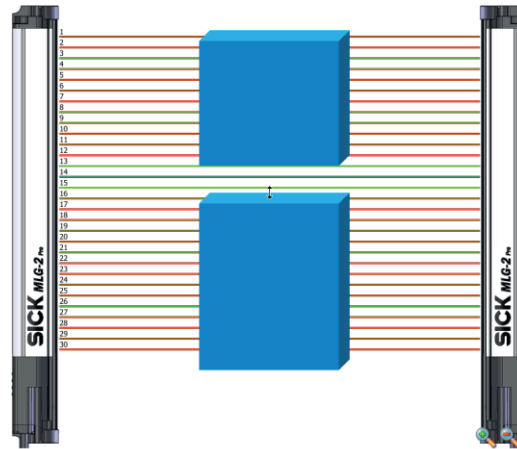

Figure 113: Setting the hole position with the mouse

Output settings

General options for switching outputs see "[Advanced settings for the outputs](#)", page 119.

8.4.8 Diagnostics

As well as measuring functions, diagnostic functions can also be assigned to the outputs. Depending on the configuration, the output will respond when certain faults occur or when the teach-in quality or process quality fall below a configured percentage.

Diagnostic settings

- **Activate Qn in the event of the following error messages:**
 - **Contamination**
The output is activated when a contamination warning occurs.
 - **Electrical short-circuit**
The output is activated when a short-circuit occurs in the wiring.
 - **Teach-in error**
The output is activated when an error occurs during the teach-in process.
 - **Hardware error**
The output is activated when an error occurs with the hardware. Possible cause: LED defective, receiver element defective, etc.
 - **Synchronization error**
Output is activated when there is an error in the connection to the server.
- **Activate Qn if the teach-in quality is under ... %**
The output is activated when the teach-in quality falls below a certain percentage (see "[Teach-in](#)", page 16).
You can define the percentage in increments of 1%.
- **Activate Qn if the process quality is under ... %**
The output is activated when the process quality falls below a certain percentage (see "[Teach-in](#)", page 16).
You can define the percentage in increments of 1%.

Output settings

General options for switching outputs see "[Advanced settings for the outputs](#)", page 119.

8.4.9 Advanced settings for the outputs

For switching outputs, you can select the option **Invert output**.

At the EXPERT user level, you can also enter a **minimum pulse width** for the output signal in ms.

Very fast or small objects trigger a short output signal. Under some circumstances, these may not be detected by slow controls. Via the minimum pulse width, you can set a pulse width that your control will detect.

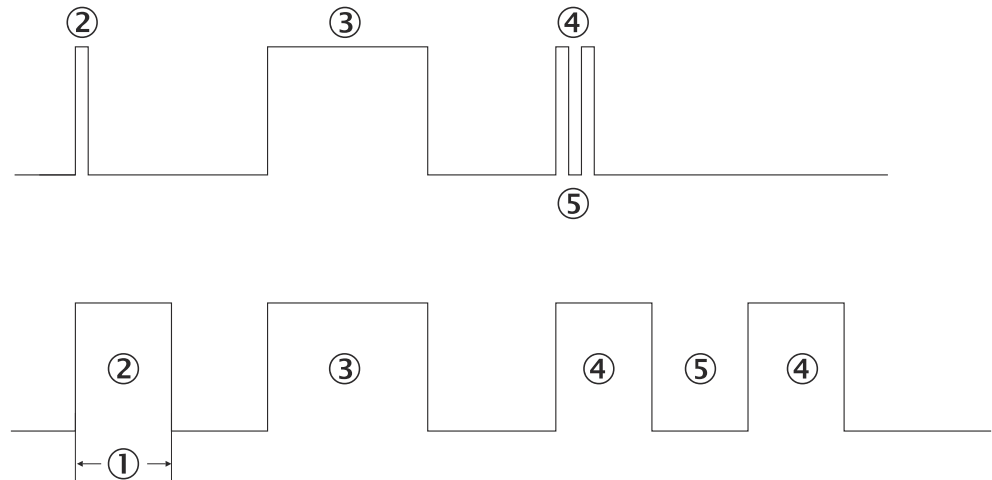

Figure 114: Examples of the effect of a configured minimum pulse width

- ① Minimum pulse width
- ② A pulse that is too short is extended.
- ③ A long output pulse remains unchanged.
- ④ Two short output pulses are extended.
- ⑤ The break also corresponds to the minimum pulse width (1).

Activating the output (only at the EXPERT user level)

At the EXPERT user level, you can also configure a setting so that an output only changes its status when a particular input is activated. This method can be used to switch the measuring function on or off.

- ▶ Click **Advanced...**
- ▶ Activate the option **Use input to activate or deactivate output**.
- ▶ Select which input is to be used.
- ▶ You should also configure whether the input is to be **high active** or **low active**.



NOTE

This function is only available if the inputs have not been configured for other functions (see "System settings for the EXPERT user level", page 103).

8.5 Zones

8.5.1 "Zone measuring" function

Prerequisites

- "Expert" user level

Description of operation

The beams of the MLG-2 can be divided into four zones. Each zone can be assigned one beam function or application. Zones and beam functions are assigned using the outputs. The functions NBB Zone n, LBB Zone n, FBB Zone n, CBB Zone n and NCBB Zone n are available for each zone (n = 1, 2, 3 or 4).

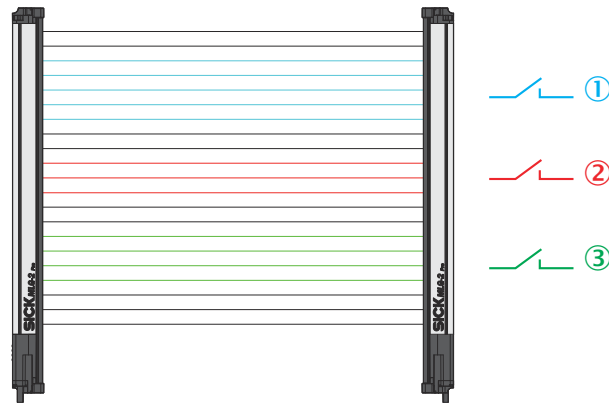

Figure 115: Measuring within zones

- ① e.g. Zone 1 (NBB Zone 1, LBB Zone 1, FBB Zone 1, CBB Zone 1 or NCBB Zone 1)
- ② e.g. Zone 2 (NBB Zone 2, LBB Zone 2, FBB Zone 2, CBB Zone 2 or NCBB Zone 2)
- ③ e.g. Zone 3 (NBB Zone 3, LBB Zone 3, FBB Zone 3, CBB Zone 3 or NCBB Zone 3)

Configuring the “Zone measuring” function using SOPAS ET

Example: You would like to assign Zone 1 and the application “Object detection/Object width (NBB/NCBB)” to digital output 1.

First, configure one or more zones. Next, assign an application and a zone to the desired output. You can configure the zones either in the beam window or via the **Zones** expandable menu.

Configuring zones in the beam window

- ▶ Click the **Zones** expandable menu.
- ▶ In the middle section of SOPAS ET (beam window), mark the beams that you would like to combine into a zone.
- ▶ Using **Combine to a zone** from the context menu, select the zone that the beams will be assigned to – in this case **Zone 1**.

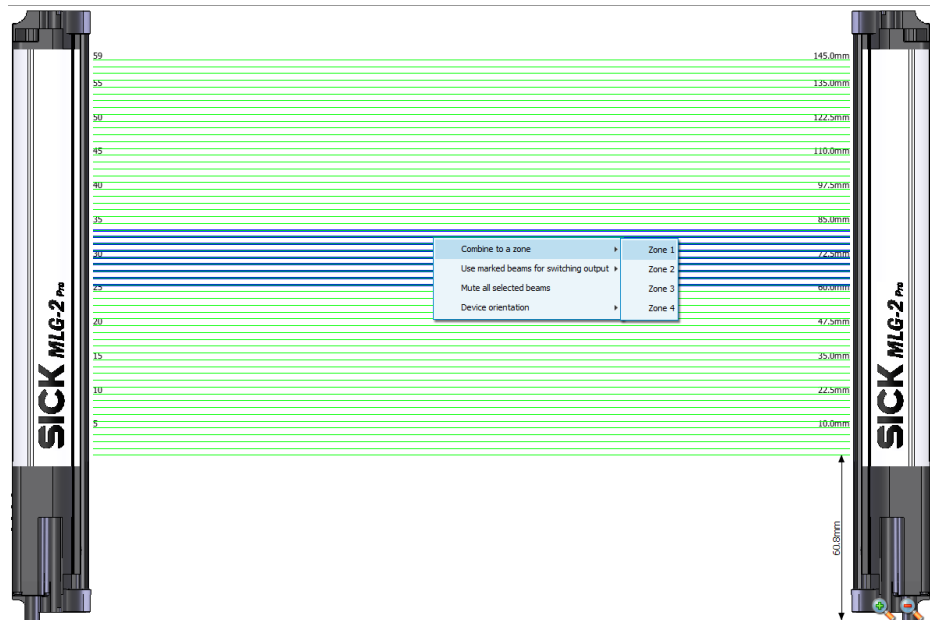

Figure 116: SOPAS ET beam window – Combining beams into zones

- ✓ The configured zones are indicated in the **Zones** expandable menu.

Configuring **Zones** in the expandable menu

- ▶ Click the **Zones** expandable menu.
- ▶ In the **Zone selection** area, define the “Zone no.”, “First beam” and “Last beam” for the zone.

Zone Nr.	First b...	Last be...
1	14	21
2	4	11
3	1	1
4	1	1

- ▶ Activate the zone you wish to assign to an output.

Configuring an output

- ▶ Click the **Digital output 1** expandable menu, for example.

Digital output 1

Applications

- Height classification (LBB/FBB)
- Height measurement of free space (LBM/FBM)
- Object recognition (RLC)
- Presence detection of objects (NBB/NCBB)**
- Presence detection of holes (NBM/NCBM)
- Outer dimension/Inner dimension (ODI/IDI)
- Position classification of object (CBB/BNB)
- Position classification of hole (CBM/BNM)

Zone Selection

Zone 1 ▼

All Rays

Ma Zone 1

Zone 2

Zone 3

Zone 4

igger or equal than ▼ 1 beams

Figure 117: SOPAS ET – Assigning an application and zone to an output

- ▶ In the **Applications** area, select an application such as **Object detection/Object width (NBB/NCBB)**.
- ▶ Using the drop-down list from the **Zone selection** area, select the zone that the application will apply to – in this case **Zone 1**.
- ✓ The configured basic function (beam function) and the related status are displayed in the **Basic functions** area of the **I/O** tab in the left-hand window, e.g., **NBB Zone 1 = 0** (number of blocked beams in Zone 1).

8.6 Teach-in

During the teach-in process, the switching thresholds for all beams are individually adjusted for the sensing range and the ambient conditions.

A teach-in process must be carried out when commissioning, when changing operating mode or performance options, and at regular intervals in general.

- ▶ Click **Teach-in**.
- ✓ The teach-in process starts. If the teach-in process is successful, a corresponding message is displayed.

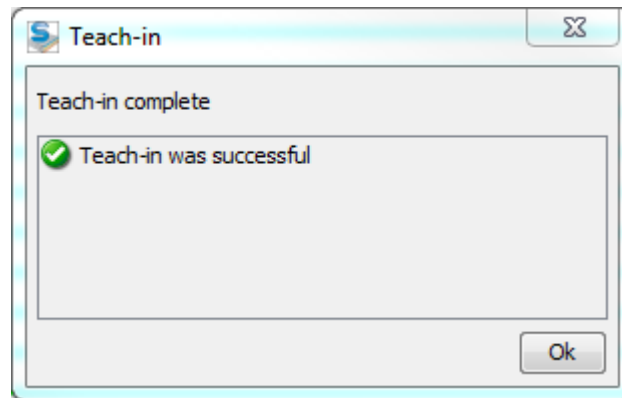

Figure 118: Teach-in successful

Similarly, if any errors occur, a corresponding message is displayed.

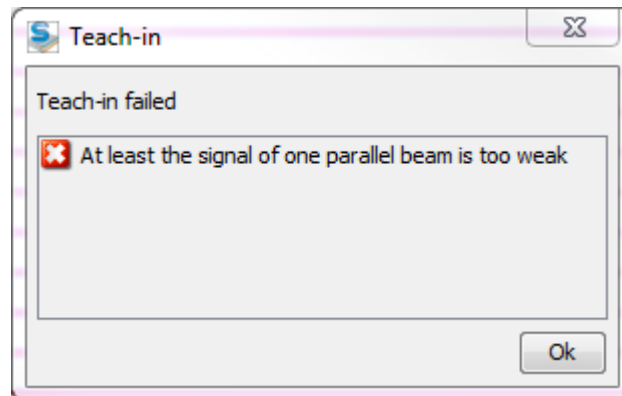

Figure 119: Teach-in failed

- ▶ Then check that the MLG-2 is correctly aligned, that the front screens are clean, and that there are no objects located in the light path.
- ▶ Then carry out the teach-in process again.

Teach-in when switching on

If you activate the **Automatic teach-in when switching on device** option, the teach-in process will be performed every time you switch on the device.

Teach-in quality

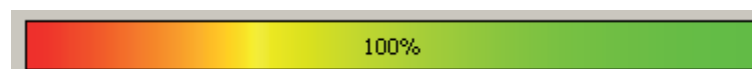

Figure 120: Teach-in quality

The teach-in quality indicates how successful the teach-in process has been. The MLG-2 calculates this value based on the quality of the light level received.

The value remains constant until another teach-in process is carried out.

Beam blanking (only at the EXPERT user level)

If you do not want to evaluate certain beams for your application, you can exclude them from the teach-in process.

Blank blocked beams as follows:

The beams from the MLG-2 that are **not** to be accounted for in the measurement must be blocked.

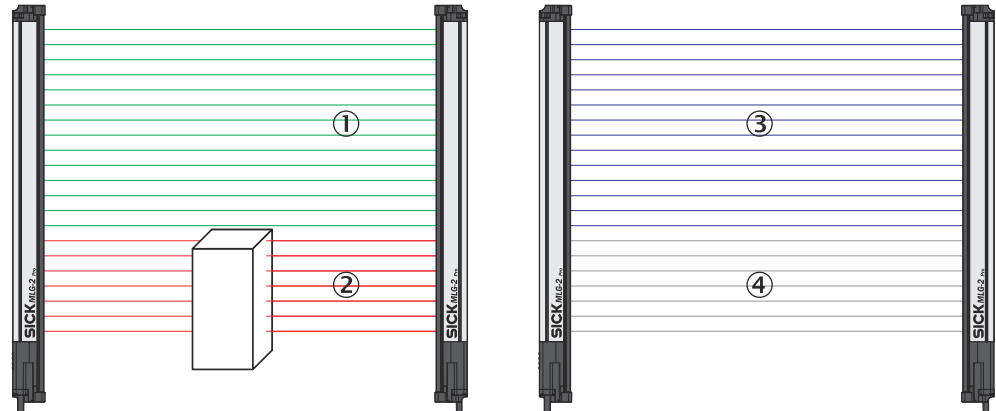

Figure 121: Example of the blanking of blocked beams

- ① Made beams
- ② Blocked beams
- ③ Beams included in the measurement
- ④ Excluded beams

- ▶ Click **Blank all blocked beams**.
- ✓ The blocked beams will not be taken into account in the measurement.
- ▶ Activate the **Activate beam blanking for every teach-in** option too.
- ✓ The blocked beams will be excluded from every teach-in process in the future.



NOTE

You will never be notified that beams are blocked during the teach-in process.

Blank made beams as follows:

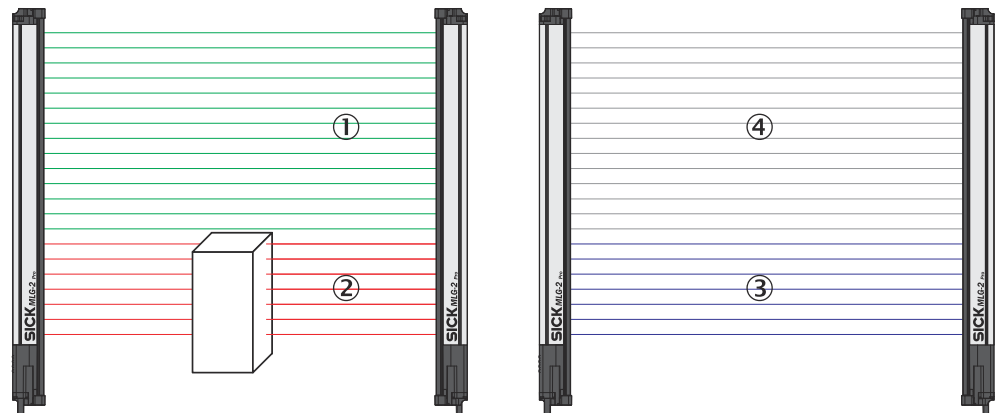

Figure 122: Example of blanking made beams

- ① Made beams
- ② Blocked beams

- ③ Beams included in the measurement
- ④ Excluded beams
- ▶ Click **Blank all made beams**.
- ✓ The made beams will not be taken into account in the measurement.
- ▶ Activate the **Activate beam blanking for every teach-in** option too.
- ✓ The made beams will be excluded from every teach-in process in the future.

8.7 Performance options

The performance options can be used to modify the response time, operating reserve, detection type, and (in Transparent operating mode), minimum detectable absorption of an object.

Responsetime

fast

—

—slow

High speed

High speed scan active

Cross beam inactive

i Recommended for high speed processes

Function Reserve

—high

—

—low

Standard

Best compromise

i Recommended for indoor applications

Detection type

Adjust object size to smallest object which needs to be detected in the application.

Object Speed

Height

Length



Figure 123: Performance options for Standard operating mode and Dust- and sunlight-resistant operating mode

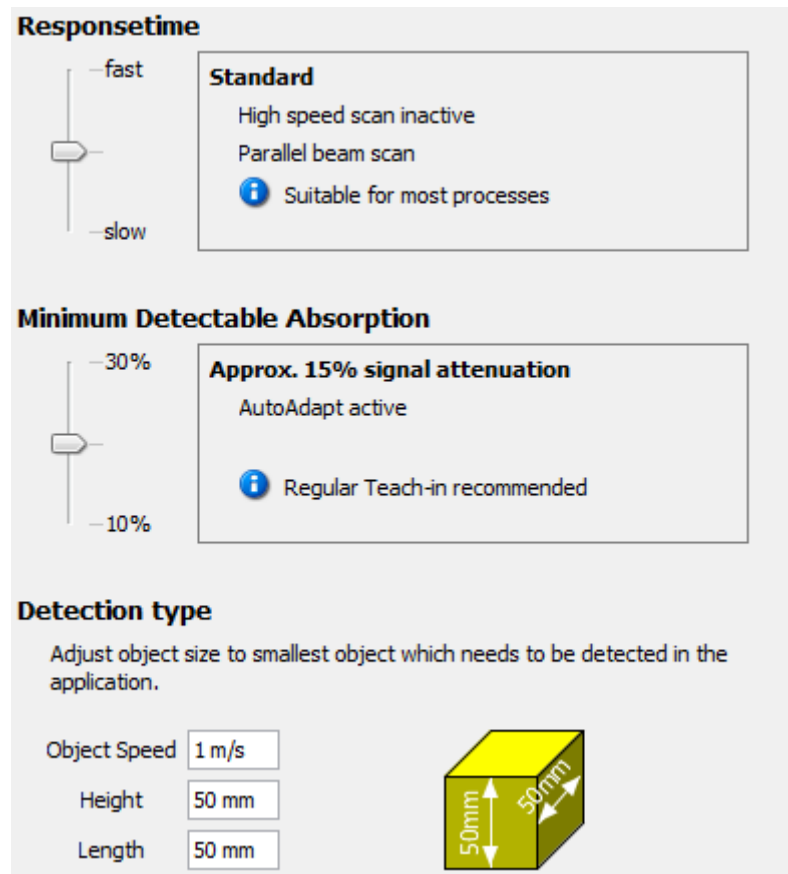

Figure 124: Performance options for Transparent operating mode

You can change the response time, operating reserve, or minimum detectable absorption by moving the slider up or down.



NOTE

- The configurable performance options depend on the operating mode selected.
- The performance options are dependent on each other.
- A teach-in process must be performed after most changes. A button is provided in the performance options for this purpose.
- ▶ Click the button to perform the teach-in process and to apply the modified performance options.
- ✓ The system boundaries resulting from the performance options are displayed on the left in SOPAS ET (see "System boundaries and status", page 95).

Response time

The response time depends on the scan method and the beam function. A short response time requires a **high-speed scan** and the **parallel-beam function**.

- ▶ Select one of the following options:
 - **Fast** – High-speed scan and parallel-beam function are active
 - **Medium** – High-speed scan not active and parallel-beam function active

**NOTE**

- If **High-speed scan** is deactivated in the energy options, you cannot switch to **Fast**.
- Only **Medium** can be set in Transparent operating mode.
- If the cross beam function is activated via **Detection type**, the system switches to **Slow**.
- For MLG-2 with a 2 m sensing range, the high measurement accuracy function must be used for **High-speed scan**.

Operating reserve

The operating reserve affects how long the measurement can be performed correctly in the event of adverse ambient conditions or contamination.

- **High** – Highly resistant to contamination, risk of reflection with shiny objects
- **Medium** – Best compromise between reflection resistance and operating reserve
- **Low** – High measurement accuracy

**NOTE**

It is not possible to set an operating reserve in **Transparent** operating mode.

Minimum detectable absorption of an object (only in Transparent operating mode)

The minimum detectable absorption (MDA) of an object must be configured in **Transparent** operating mode. In order to detect a transparent object, it must absorb a certain percentage of the energy from the light beam.

The following options are available for configuring the minimum detectable absorption⁶⁾:

- Approx. 10% signal attenuation:
clean PET bottles, clear glass, thin and clear films (e.g., cellophane), household plastic film, plastic wrapping
- Approx. 15% signal attenuation:
clean clear glass bottles, thick films, film and wrapping folded multiple times
- Approx. 30% signal attenuation:
green and brown glass, colored glass bottles

**NOTE**

The minimum detectable absorption that an object needs in order to be detected increases with the sensing range (see "[Minimum detectable absorption](#)", page 150).

Detection type

With the help of the mapped object, you can set the minimum detectable object size and minimum detectable object length, and enter the speed of the object through the detection area.

The object speed and size determine which scanning procedure is to be used.

- ▶ Enter the speed at which the object being detected will move through the detection area in the **Object speed** field.
- ▶ Enter the height of the smallest object to be detected in the **Height** field.
- ▶ Enter the length of the smallest object to be detected in the **Length** field.

The figure to the right of the fields shows the entered values in proportion.

⁶⁾ Examples are for illustrative purposes only. The signal attenuation and the minimum detectable absorption to be configured must be determined for each individual application.

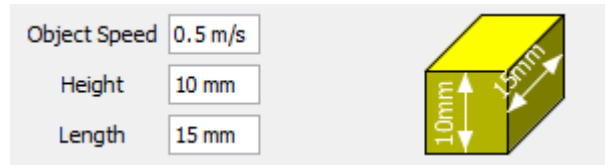

Figure 125: Illustration of the measuring object

8.7.1 “Cross beam” function

Prerequisites

- “Expert” user level
- Reasonable beam separation: ≥ 10 mm
- Possible operating modes: standard or dust- and sunlight-resistant
- High-speed scan is deactivated.
- The object being detected is located in the center section of the detection area.
- Only for “Cross beam measuring”: ≤ 255 beams

Notes

- see "Minimum detectable object with cross-beam function ", page 22

Description of operation

The MLG-2 offers the following beam functions: “Parallel beam”, “Cross beam switching” and “Cross beam measuring.” The system automatically selects the “Parallel beam” or “Cross beam switching” function depending on the specific object size that is to be detected. As an alternative, the user also has the option of manually activating the “Cross beam switching” or “Cross beam measuring” function.

In the “Cross beam switching” option, the crossed beams are also used for object detection. The crossed beams do not affect the beam status, beam functions or blanked beams.

In the “Cross beam measuring” function, a group of crossed beams is combined into a single virtual beam. Virtual beams are treated as additional real beams and do not have any affect on the beam status, beam functions or blanked beams. If the “Cross beam measuring” function is activated, the real and virtual beams are renumbered, which means that the number of beams is nearly doubled.

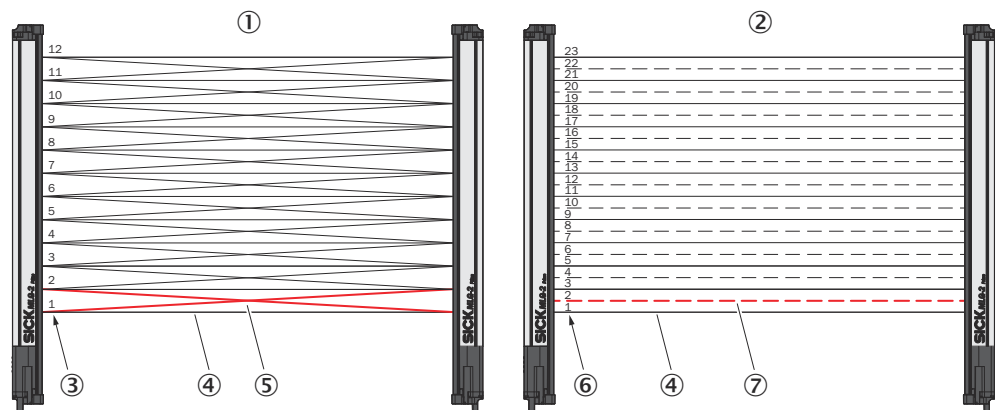

Figure 126: Left: “Cross beam switching”, right: “Cross beam measuring”

- ① Cross beam switching
- ② Cross beam measuring
- ③ Beam numbering for “Cross beam switching”
- ④ Parallel beam
- ⑤ Crossing beams

- ⑥ Beam numbering for “Cross beam measuring”
- ⑦ Crossing beams, displayed as a virtual beam

Example with “Cross beam measuring”

When the “Cross beam switching” function is used, a light grid with a beam separation of 20 mm can detect a wide object with a thickness of 1 mm, but cannot output a measured value for the height, for example. With the “Cross beam measuring” function, it is also possible to output a measured value for the height.

Configuring the “Cross beam switching” function using SOPAS ET

- ▶ In SOPAS ET, click on the **Performance options** expandable menu in the right-hand window.
- ▶ In the **Operating reserve** area, enable the **Activate cross beam mode** function.

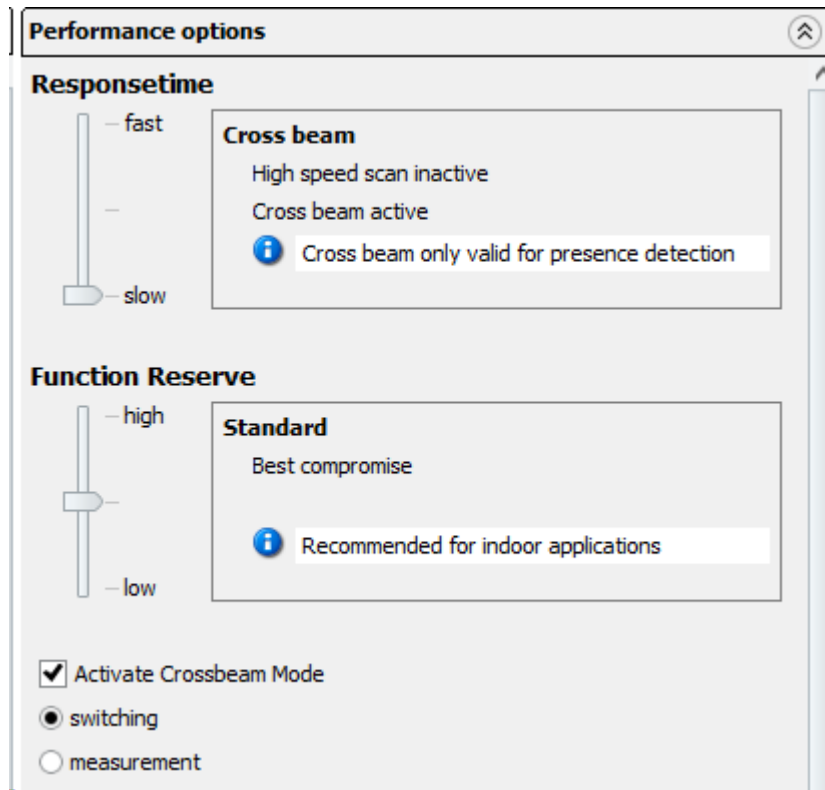

Figure 127: SOAPS ET – Activating cross beam switching mode

- ▶ Select the **switching** function.
- ✓ The “Cross beam switching” function is now activated.

Configuring the “Cross beam measuring” function using SOPAS ET



NOTICE

If the “Cross beam measuring” function is activated, the real and virtual beams are renumbered. Existing configurations are not converted. Check the existing configuration for the “Cross beam measuring” function. Adjust the configuration accordingly.

- ▶ In SOPAS ET, click on the **Performance options** expandable menu in the right-hand window.
- ▶ In the **Operating reserve** area, enable the **Activate cross beam mode** function.

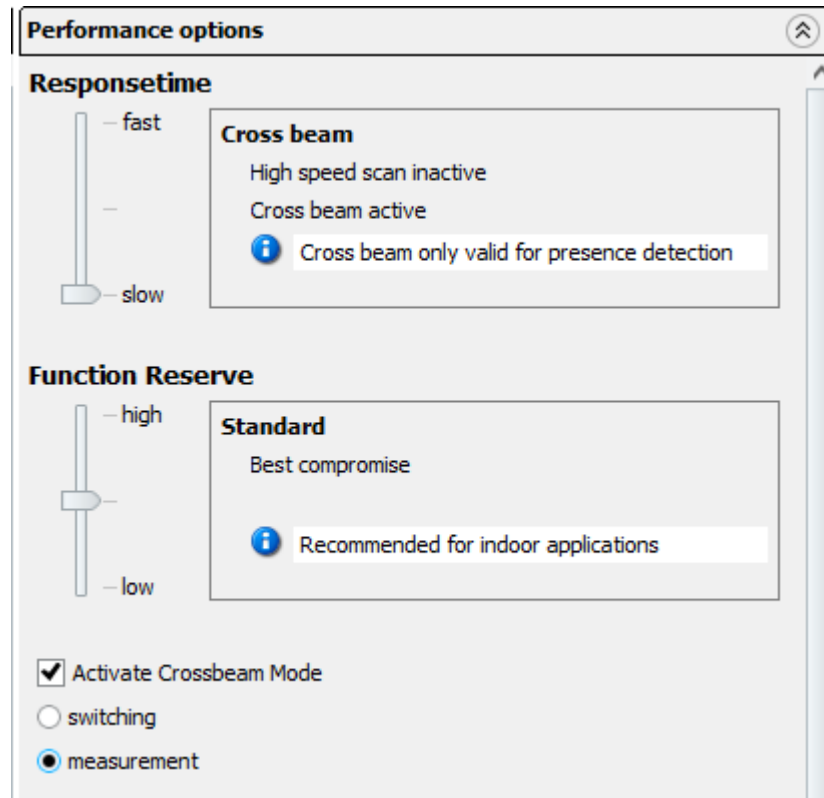

Figure 128: SOAPS ET – Activating cross beam measuring mode

- ▶ Select the **measuring** function.
- ✓ The following dialog box will open: **Warning. Activating this function will increase the number of beams. All beam-dependent settings must be adjusted accordingly.**

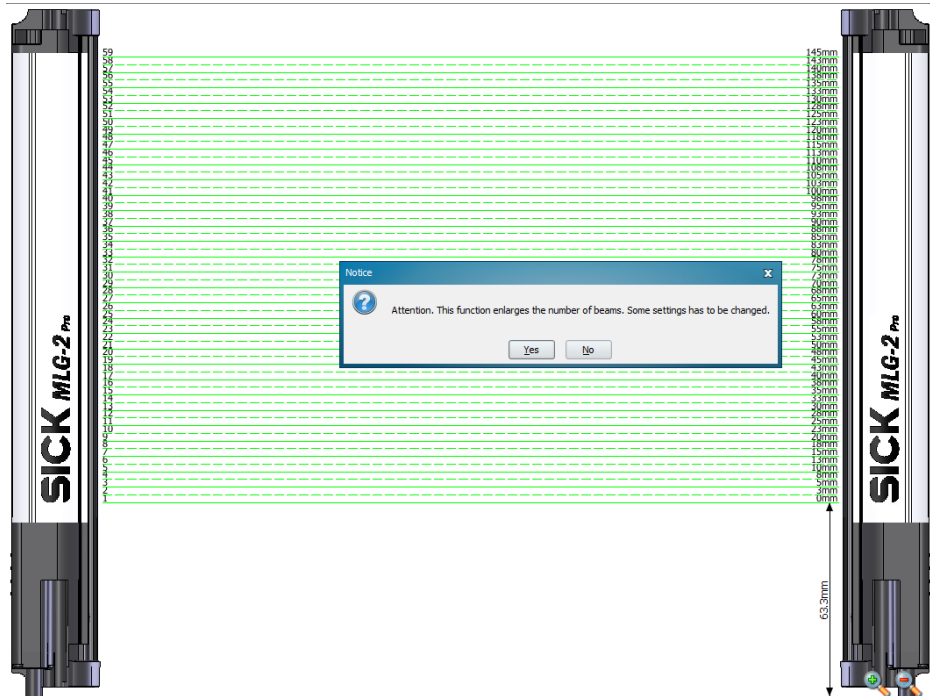

Figure 129: SOAPS ET, beam window – “Cross beam measuring” display

- ▶ Click **Yes** to activate the **Cross beam measuring mode**. Click **No** to cancel.
- ✓ The light grid display is adjusted in the middle section (beam window). The real

and virtual beams are renumbered and, as a result, the number of beams is nearly doubled. The virtual beams are displayed as dashed lines.

- ▶ Check the existing configuration for the “Cross beam measuring” function.
- ▶ Adjust the configuration for the “Cross beam measuring” function accordingly.

8.7.2 Energy option (only at the EXPERT user level)

Deactivating the high-speed scan function

Since the high-speed scan function results in a higher current consumption, it can be deactivated. In this case, the function cannot be activated again via the response time slider.

8.8 Beam evaluation

8.8.1 “Blocked Beams Hold (BBH)” evaluation mode

Prerequisites

- “Expert” user level

Notes

- You can choose one of the following evaluation modes: Standard, Blocked Beams Hold (BBH) or Lost Beams Hold (LBH).
- You can select the “Blocked Beams Hold (BBH)” evaluation mode for one beam function or for multiple beam functions simultaneously.

Description of operation

The “Blocked Beams Hold (BBH)” evaluation mode is activated by a trigger signal on the hardware input or via a trigger command from the fieldbus. If this evaluation mode has been activated, any beams that have been blocked are saved and displayed as blocked beams. Once the evaluation mode is deactivated by a withdrawal of the trigger signal, the blocked beams are reset to made beams.

You can select the “Blocked Beams Hold (BBH)” evaluation mode for each individual beam function or for multiple beam functions simultaneously. As a result, beam functions for which the “Blocked Beams Hold (BBH)” evaluation mode was configured are calculated based on this evaluation mode.

Configuring the “Blocked Beams Hold (BBH)” function using SOPAS ET

Beam Evaluation

Evaluation Mode

Standard

Blocked Beams Hold

Lost Beams Hold

Configuration

Blocked Beams selected};
This Function only affects the selected Basicfunctions.

Use digital input to trigger
BlockedBeamsHold

Use input No.

Simulated BBH-Triger value

BBH Beamfunction

NBB

NBM

FBB

Figure 130: SOPAS ET – “Blocked Beams Hold (BBH)” function

- ▶ In SOPAS ET, click on the **Beam evaluation** expandable menu in the right-hand window.
- ▶ In the **Evaluation mode** area, select the **Blocked Beams Hold (BBH)** evaluation mode.
- ✓ The message **Blocked Beams Hold selected. This function only affects the selected basic functions.**
- ▶ In the **BBH beam function** area, activate the beam functions for which the Blocked Beams Hold evaluation mode will be used.
- ▶ If the evaluation mode is to be activated and deactivated using a hardware input, check the **Use digital input to activate BlockedBeamsHold** box.
- ▶ Select the desired digital input from the drop-down list.
Please note that you can only assign one function to an input. If necessary, you must deactivate the **Use digital input to start teach process** option in the **Teach-in** expandable menu.
- ✓ In the **I/O** tab in the left-hand window, the beam functions for which the output mode was selected are marked by **(BBH)**. The message **TRIGGER_BBH_MODE** is displayed in the **Input/Output status** area if the “BBH” evaluation mode was activated by an input.

8.8.2 “Lost Beams Hold (LBH)” evaluation mode

Prerequisites

- “Expert” user level

Notes

- You can choose one of the following evaluation modes: Standard, Blocked Beams Hold (BBH) or Lost Beams Hold (LBH).
- The “Lost Beams Hold (LBH)” evaluation mode affects all beam functions.

Description of operation

In the “Lost Beams Hold (LBH)” evaluation mode, a blocked beam is displayed as a blocked beam until a new beam is blocked. This allows the position to be determined for objects that are smaller than the minimum detectable object.

This evaluation mode assumes that the object being detected is always positioned within the detection area. This means that the object must be located either above or below the last beam blocked when a previously blocked beam is no longer blocked and a different beam is not yet blocked. Once the object blocks a different beam, this new position is detected and the saved last beam blocked is deleted. If the object moves outside the detection area, the last beam blocked remains blocked.

Example

The “Lost Beams Hold (LBH)” output mode is used to detect the position of thin objects that are no longer detected by a parallel beam.

Configuring the “Lost Beams Hold (LBH)” function using SOPAS ET

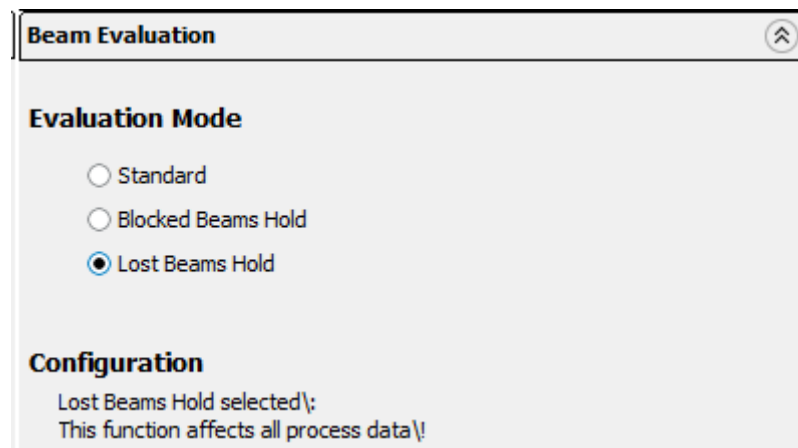

Figure 131: SOPAS ET – “Lost Beams Hold (LBH)” function

- ▶ In SOPAS ET, click on the **Beam evaluation** expandable menu in the right-hand window.
- ▶ In the **Evaluation mode** area, select the **Lost Beams Hold (LBH)** evaluation mode.
- ✓ The message **Lost Beams Hold selected.** is displayed in the **Configuration** area. **This function affects all process data.**
- ✓ At the bottom of the **I/O** tab in the left-hand window, the beam evaluation mode **OFF**, **Blocked Beams Hold** or **Lost Beams Hold** is displayed.

8.9 Simulation

If you configure an MLG-2 offline – i.e., without a connection to the device – you can simulate the operation of the MLG-2 using simulation objects. The objects required for the simulation can be set via the expandable **Simulation** menu. This includes the number of objects, their shape, size, and speed.

- ▶ Click on the plus sign to add a simulation object.

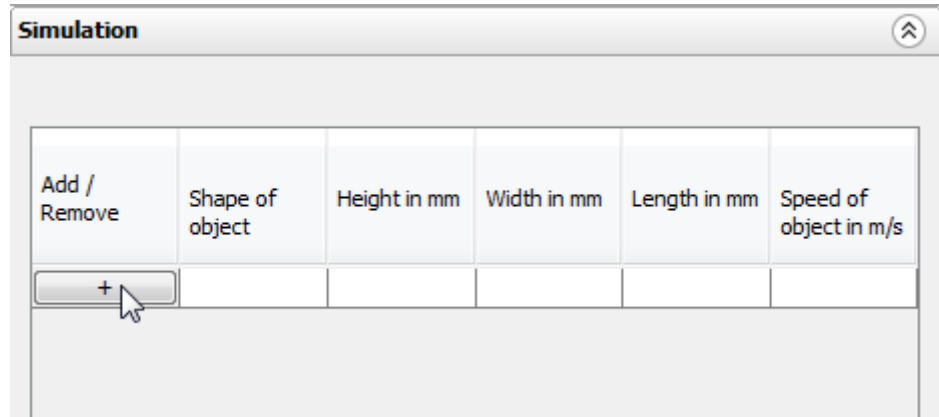

Figure 132: Add simulation object

- ▶ Select the object shape.

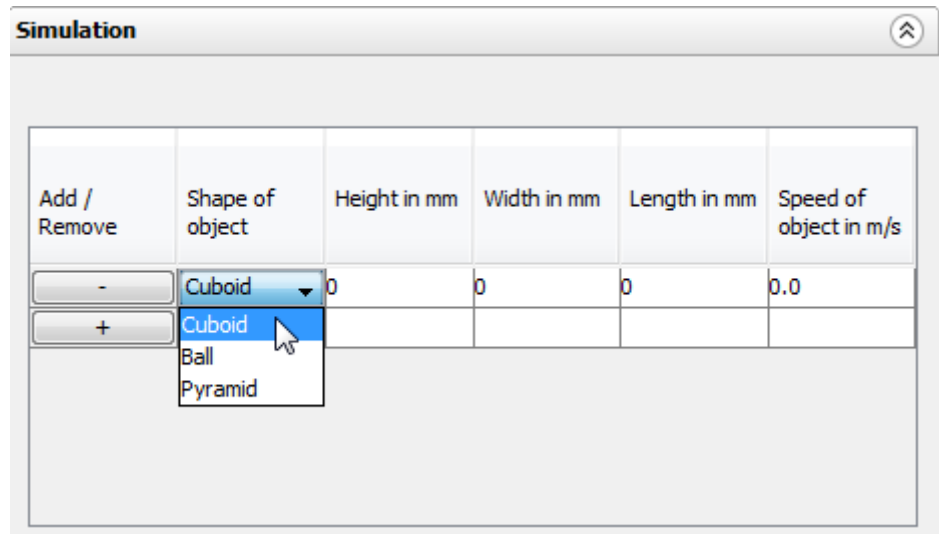

Figure 133: Determine the shape of the simulation object

- ▶ Enter the height, width, and length in mm. Enter the object speed in m/s.

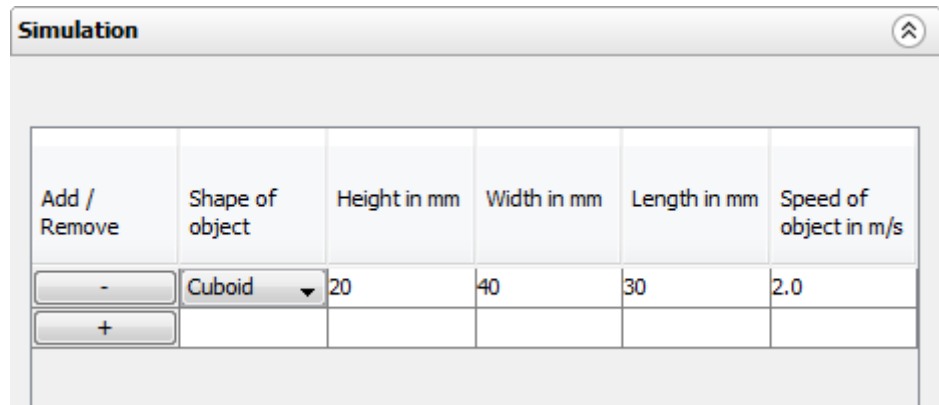

Figure 134: Determine the size of the simulation object

- ▶ Click **Start simulation**.

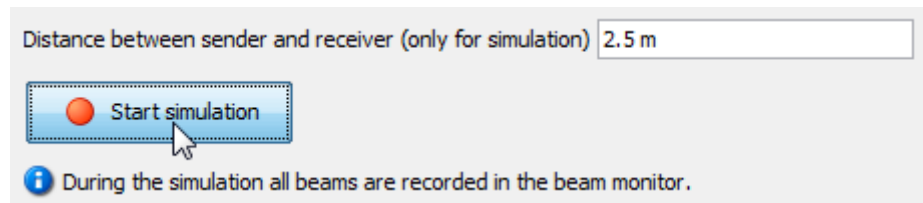

Figure 135: Start simulation

- ✓ The configured simulation object is moved through the MLG-2 in the **Simulation** area.

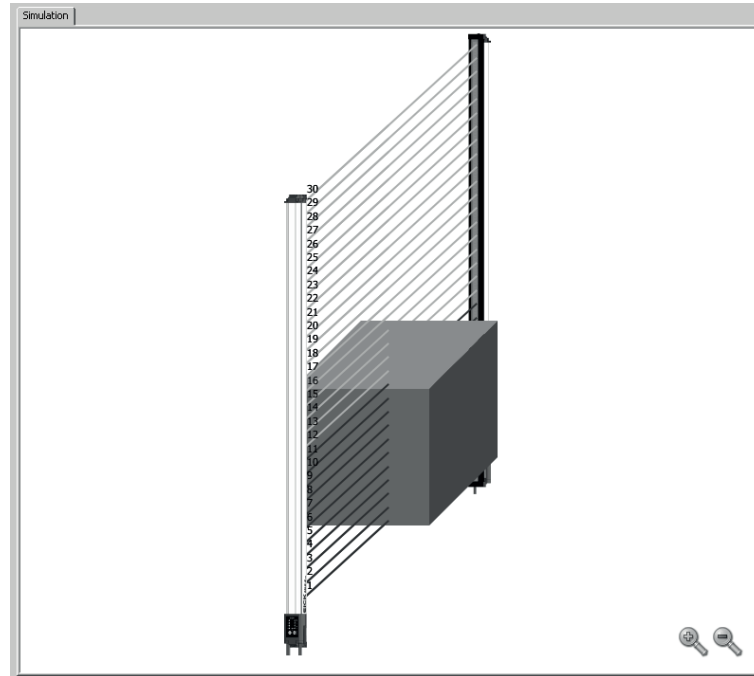

Figure 136: Simulation object in Simulation area

8.10 Beam monitor (only in the EXPERT user level)

If SOPAS ET is connected to an MLG-2, the **Beam monitor** tab shows the current beam status as a function of time as well as the status of the configured outputs.

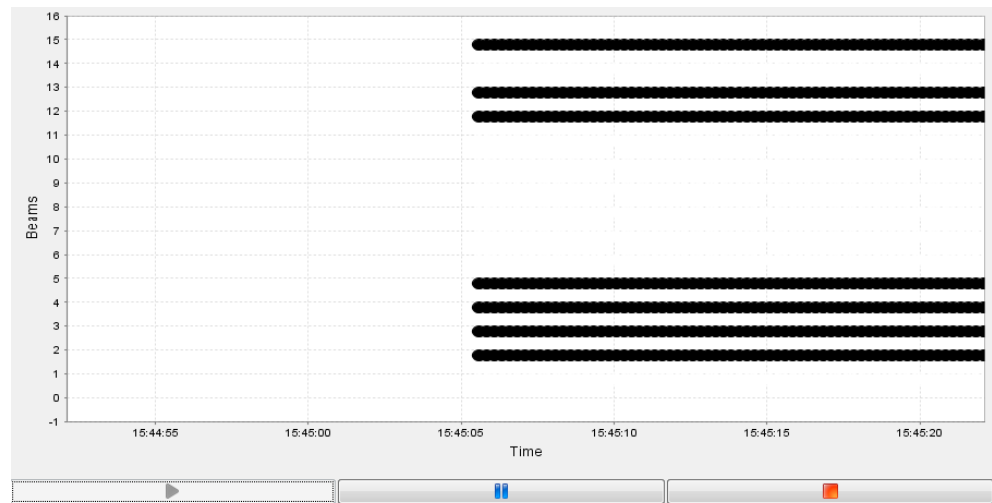

Figure 137: Beam status

This not only shows whether the beam is blocked or made, but also indicates partial coverage of the beam using grayscale, i.e., a half-blocked beam is shown in 50% gray.

If an object is moved through the detection area within the simulation while offline, the made and blocked beams are recorded just as in online operation. If the object is moved using the mouse, only the static beam status is displayed.

8.11 Function programming (in the EXPERT user level)

Function programming can be used to carry out complex applications with variables, operands, and functions in the **EXPERT** user level.

1st option:

“Beam function variables” can be defined in the **Beam function variables** area using the beam functions (see ["Beam functions"](#), page 138).

Example:

BFVar 1: Total number of beams made (NBM) \geq 30

These variables can be linked directly to the outputs in the **Switching outputs** area.

Example:

Q1 = BFVar 1 = true

Output Q1 switches when the total number of beams made is greater than or equal to 30.

2nd option:

Multiple beam function variables can be defined in the **Beam function variables** area using the beam functions (see ["Beam functions"](#), page 138).

Example:

BFVar 1: Number of beams made (NBM) \geq 30

BFVar 2: Number of consecutive beams blocked (NCBB) = 5

These can be linked to logical variables in the **Logical variables** area.

Example:

LogVar1 = BFVar 1 OR BFVar 2

The logical variables can be linked in turn to the outputs (Q) in the **Switching outputs** area.

Example:

Q1 = LogVar1

The output Q1 switches when the total number of beams made is greater than or equal to 30 or when the number of consecutive beams blocked equals 5.



NOTE

If outputs have already been configured using the operating elements available in the **Easy** user level, these settings will be automatically transferred to the **Function programming** view.

Beam function variables				
Name	Beam Function	Operation	Value	Result
BFVar1	ODI	≤	10	
BFVar2	LBB	=	15	
BFVar3	NBB	=	0	
BFVar4	NBB	=	0	
BFVar5	NBB	=	0	
BFVar6	NBB	=	0	
BFVar7	NBB	=	0	
BFVar8	NBB	=	0	
BFVar9	NBB	=	0	
BFVar10	NBB	=	0	

Combination of logical variables				
Name	BFVar/Input	Operation	BFVar/Input	Result
LogVar1	BFVar1	AND	BFVar1	
LogVar2	BFVar1	AND	BFVar1	
LogVar3	BFVar1	AND	BFVar1	
LogVar4	BFVar1	AND	BFVar1	
LogVar5	BFVar1	AND	BFVar1	
LogVar6	BFVar1	AND	BFVar1	
LogVar7	BFVar1	AND	BFVar1	
LogVar8	BFVar1	AND	BFVar1	
LogVar9	BFVar1	AND	BFVar1	
LogVar10	BFVar1	AND	BFVar1	

Digital outputs/virtual outputs		
Name	Connection	Variable
Q1	=	ZONE1
Q2 (virtual)	=	BFVar2
Q3 (virtual)	=	BFVar3
Q4 (virtual)	=	BFVar4
Q5 (virtual)	=	OT1
Q6 (virtual)	=	OT1
Q7 (virtual)	=	OT1
Q8 (virtual)	=	OT1
Q9 (virtual)	=	OT1
Q10 (virtual)	=	OT1
Q11 (virtual)	=	OT1
Q12 (virtual)	=	OT1
Q13 (virtual)	=	OT1
Q14 (virtual)	=	OT1
Q15 (virtual)	=	OT1
Q16 (virtual)	=	OT1

Figure 138: Function programming

8.11.1 Beam functions

Table 115: Beam functions for preliminary evaluation

Name	Function (English)	Function (German)	Description
NBB	Number of Beams Blocked	Anzahl unterbrochener Strahlen	Total number of beams blocked (e.g., for object detection)
NBM	Number of Beams Made	Anzahl freier Strahlen	Total number of beams made (e.g., for hole detection)
NCBB	Number of Consecutive Beams Blocked	Anzahl zusammenhängender unterbrochener Strahlen	If there are multiple objects in the detection area, the greatest number of consecutive beams blocked is displayed.
NCBM	Number of Consecutive Beams Made	Anzahl zusammenhängender freier Strahlen	If there are multiple gaps in the detection area, the greatest number of consecutive beams made is displayed.
LBB	Last Beam Blocked	Letzter unterbrochener Strahl	Beam number of the last beam blocked (e.g., for object height measurement)
LBM	Last Beam Made	Letzter freier Strahl	Beam number of the last beam made
FBB	First Beam Blocked	Erster unterbrochener Strahl	Beam number of the first beam blocked (e.g., for height classification of a hanging object)
FBM	First Beam Made	Erster freier Strahl	Beam number of the first beam made
ODI	Outside Dimension	Außenmaß	Total number of beams between the first and last beams blocked (e.g., for measuring the outside dimension)
IDI	Inside Dimension	Innenmaß	Total number of beams made between the first and last beams blocked (e.g., for measuring the inside dimension)
CBB	Central Beam Blocked	Zentraler unterbrochener Strahl	Beam number of the central beam blocked (e.g., for measuring an object position)
CBM	Central Beam Made	Zentraler freier Strahl	Beam number of the central beam made (e.g., for measuring a hole position)
BNB	Beam Number Blocked	Strahlnummer x unterbrochen	True when a predefined beam is blocked
BNM	Beam Number Made	Strahlnummer x frei	True when a predefined beam is made
ALARM Q1	-	-	Configuration same as with SOPAS ET
QoR	Quality of Run	Process quality	0 ... 100 percent
QoT	Quality of Teach	Teach-in quality	0 or 100 in percent 0 = teach-in was unsuccessful 100 = teach-in was successful
RLC1 ... 16	Run-length code	-	Outputs the value of the relevant change
NBB Zone X (X = 1, 2, 3 or 4)	Number of Beams Blocked Zone X	Number of Beams Blocked Zone X	Total number of beams blocked (e.g., for object detection) in the indicated zone

Name	Function (English)	Function (German)	Description
NCBB Zone X (X = 1, 2, 3 or 4)	Number of Consecutive Beams Blocked Zone X	Number of Consecutive Beams Blocked Zone X	If there are multiple objects in the detection area, the greatest number of consecutive beams blocked in the indicated zone is displayed.
FBB Zone X (X = 1, 2, 3 or 4)	First Beam Blocked Zone X	First Beam Blocked Zone X	Beam number of the first beam blocked (e.g., for object height measurement) in the indicated zone
LBB Zone X (X = 1, 2, 3 or 4)	Last Beam Blocked Zone X	Last Beam Blocked Zone X	Beam number of the last beam blocked (e.g., for object height measurement) in the indicated zone
CBB Zone X (X = 1, 2, 3 or 4)	Central Beam Blocked Zone X	Central beam blocked in Zone X	Beam number of the central beam blocked (e.g., for measuring an object position) in the indicated zone

9 Configuration of MLG-2 with the internal web server

The MLG-2 has an integrated web server which can be used to configure the MLG-2 even without SOPAS ET. However, not all parameters can be configured, and the web server does not provide the same diagnostics options.



NOTE

The interface is only available in English.



The screenshot shows the web server interface with the following sections:

- Navigation:** Device Information (selected), System Configuration, Output Configuration, Diagnosis.
- Device Information:**
 - Identification:** Product: MLG-2 Pro, Order Number: MLG05A-0145B10501, Vendor: SICK AG, Serial Number: 14130006.
 - Location of Device:** A text input field containing asterisks and a "Save Changes" button.
 - Version:** Hardware Version: S000, Software Version: V001.000.000, IO-Link Revision: V1.1.
 - Full configuration access:** A link to "Download SOPAS ET here" to get full configuration access to the device! Below it, it says "Evaluation Server."
- Language:** English (dropdown menu).
- System boundaries:**
 - Reproducibility: 0.72 ms
 - Min. Presence time: 1.44 ms
 - Response Time: 3.63 ms
 - MDO: 9.00 mm
 - Process Quality: 100%
 - Device Status: ■ Device is working
- Output Status:**
 - Q1: ■
 - IN2: ■
 - Qa1: 4.00 mA
 - Qa2: 4.00 mA
- Footer:** Press F5 to refresh the page!

Figure 139: Interface of the integrated web server

Accessing the web server

The MLG-2 web server is accessed via the IP address of the MLG-2.

On delivery, DHCP is deactivated and the static IP address 192.168.200.100 is set.

If DHCP is activated and a DHCP server is on the network, the MLG-2 obtains the IP address from this server. You can look up the IP address there.

The MLG-2 supports universal plug and play. This means that you can also find the IP address in the system settings of your Windows PC/notebook.

Working with the web server

The displayed values are not always updated automatically. The browser page may therefore need to be refreshed (e.g., by pressing F5).

10 Servicing

The MLG-2 measuring automation light grid is maintenance-free. Depending on the ambient conditions, regular cleaning is required.

Depending on the ambient conditions of the MLG-2, the front screens must be cleaned regularly and in the event of contamination. Static charges can cause dust particles to be attracted to the front screen.



NOTE

- ▶ Do not use aggressive cleaning agents.
 - ▶ Do not use abrasive cleaning agents.
 - ▶ Do not use cleaning agents that contain alcohol, e.g., window cleaner.
-

We recommend anti-static cleaning agents.

We recommend the use of anti-static plastic cleaner (SICK part number 5600006) and the SICK lens cloth (SICK part number 4003353).

How to clean the front screen:

- ▶ Use a clean, soft brush to remove dust from the front screen.
- ▶ Then wipe the front screen with a clean, damp cloth.
- ▶ Check the position of the sender and receiver after cleaning.
- ▶ Perform the teach-in process on the MLG-2 again. To do this, press the **Teach** pushbutton.

11 Troubleshooting

This chapter describes how to identify faults on the MLG-2.

11.1 Response to faults



CAUTION

Cease operation if the cause of the malfunction has not been clearly identified.

Immediately put the machine out of operation if you cannot clearly identify the fault and if you cannot safely remedy the problem.

11.2 SICK support

If you cannot remedy the error with the help of the information provided in this chapter, please contact your respective SICK subsidiary.

11.3 LED indicators and error indicators

This section explains what the LED error indicators mean. The status indicators are described in a separate section [see "Display and operating elements", page 31.](#)

LEDs on the front of the sender

Table 116: LED indicators on the sender

Yellow LED	Red LED	Green LED	Meaning
○	○	○	Supply voltage off or too low
○	○	●	Supply voltage on
☉ 1Hz	○	●	Test input active
○	●	○	Hardware error

LEDs on the front of the receiver

Table 117: LED indicators on the receiver

Yellow LED	Red LED	Green LED	Meaning
○	○	○	Supply voltage off or too low
○	○	●	Supply voltage on
●	○	●	Light path blocked (at least one beam blocked)
☉ 1Hz	○	●	Teach-in active
☉ 3 Hz	○	●	Contamination warning or alignment aid active and alignment poor
☉	☉	☉	“Find Me” function active If multiple MLG-2s are installed in one application, you can activate the “Find Me” function to identify a certain MLG-2.
○	☉ 10 Hz	○	Error occurred during teach-in, at least one beam blocked
○	●	○	Hardware error
●	●	○	Synchronization error
○	●	●	Short-circuit

LEDs on the fieldbus module

Table 118: LEDs on the fieldbus module

LED	Meaning
POWER	
●	Supply voltage on
○	Supply voltage off or too low
LINK/ACT	
●	Ethernet connection present
○	No Ethernet connection
● 1 Hz	Data is being received or sent
STATUS⁷⁾	
● Green	No error, data is being exchanged between the master and slave.
● Green	***TBD***
● Red	Bus error, faulty connection, data exchange is not possible.
● Red	Incorrect parameters, data exchange is not possible. The MLG-2 is not configured or has been configured incorrectly (e.g., incorrect address setting).
● Red/green	System error, data can be exchanged with the MLG-2. Diagnostic information is available.

11.4 Advanced diagnostics on the MLG-2

The supplied SOPAS ET software contains advanced diagnostics options. These options allow you to further isolate the problem if the error situation is unclear or if there are availability issues. You can find detailed information:

- In the Status field (in the bottom left of the main screen)
- In the system boundaries display (minimum detectable object for the current configuration, minimum presence time, reproducibility, response time)

⁷⁾ The STATUS LED follows the respective fieldbus specification

12 Decommissioning

12.1 Disposal

Always dispose of serviceableness devices in compliance with local/national rules and regulations with respect to waste disposal.



NOTE

We would be pleased to be of assistance on the disposal of this device. Please contact us.

12.2 Returns

To enable efficient processing and allow us to determine the cause quickly, please include the following when making a return:

- Details of a contact person
- A description of the application
- A description of the fault that occurred

13 Technical data

13.1 Data sheet

General data

Table 119: MLG-2 data sheet – General data

Protection class	III (EN 61140)
Enclosure rating	IP 65 and IP 67 (EN 60529) ¹⁾
Ambient operating temperature	-30 ... +55 °C
Storage temperature	-40 ... +70 °C
Vibration resistance	5 g, 10 ... 55 Hz (EN 60068-2-6)
Shock resistance (EN 60068-2-27)	<ul style="list-style-type: none"> • Single shock • Continuous shock
Electromagnetic compatibility	According to EN 61000-6-2 Interference immunity for industrial environments and EN 61000-6-4 Emission standard for industrial environments
MTTF MTBF	15 years 15 years
Dimensions	see "Dimensional drawings", page 151
Weight	Sender + receiver approx. 2 kg/m + 0.1 kg
Materials	<ul style="list-style-type: none"> • Housing • Front screen
	<ul style="list-style-type: none"> • Aluminum, anodized • PMMA

¹⁾ Do not use light grids outdoors unless protected (condensation will form).

Electrical specifications (for 24 V DC and 25 °C ambient temperature)

Table 120: MLG-2 data sheet – Electrical specifications

Supply voltage V_S	24 V DC \pm 20%
Residual ripple (within V_S)	< 10%
Current consumption of sender	<ul style="list-style-type: none"> • Typical • Maximum • With 3x high-speed scan
Current consumption of receiver	<ul style="list-style-type: none"> • Typical • Maximum • In Dust- and sunlight-resistant operating mode, where a beam of 150 klx is sent to all receiver optics
Required overcurrent protection when using the following wire gages	<ul style="list-style-type: none"> • AWG 20/0.52 mm² • AWG 22/0.32 mm² • AWG 24/0.20 mm² • AWG 26/0.13 mm² • AWG 28/0.08 mm² • AWG 30/0.05 mm²
	<ul style="list-style-type: none"> • 40 mA + (0.1 mA \times number of beams) • <55 mA + (0.1 mA \times number of beams) • <100 mA + (0.1 mA \times number of beams)
	<ul style="list-style-type: none"> • 60 mA + (0.25 mA \times number of beams) • < 80 mA + (0.25 mA \times number of beams) • < 80 mA + (0.55 mA \times number of beams)
	<ul style="list-style-type: none"> • 5 A • 3 A • 2 A • 1 A • 0.8 A • 0.5 A

Output signal switching device

Table 121: MLG-2 data sheet – Switching outputs

Switching type	Push-pull
Logic level switching points <ul style="list-style-type: none"> • HIGH • LOW 	<ul style="list-style-type: none"> • $V_S - 3\text{ V}$ • $< 3\text{ V}$
Maximum output current per output	100 mA
Output load per output <ul style="list-style-type: none"> • Capacitive • Inductive 	<ul style="list-style-type: none"> • 100 nF • 1 H
Response time	see figure 140, page 148

Technical measurement data

Table 122: MLG-2 data sheet – Technical measurement specifications

Wavelength	850 nm
Ambient light immunity <ul style="list-style-type: none"> • Standard operating mode • Dust- and sunlight-resistant operating mode¹⁾ 	<ul style="list-style-type: none"> • 150,000 lx (constant light, indirect) • 150,000 lx (constant light, direct and indirect)
Minimum detectable object for devices with 5 mm, 10 mm, 20 mm, 25 mm, 30 mm, 50 mm beam separation <ul style="list-style-type: none"> • With normal measurement accuracy • With high measurement accuracy • In Transparent operating mode • Cross beam function 	<ul style="list-style-type: none"> • Beam separation + 4 mm • Beam separation • Beam separation²⁾ • $0.5 \times \text{beam separation} + 4\text{ mm}$
Minimum detectable object for devices with 2.5 mm beam separation <ul style="list-style-type: none"> • With normal measurement accuracy • With high measurement accuracy • In Transparent operating mode • Cross beam function 	<ul style="list-style-type: none"> • Beam separation + 1 mm • Beam separation • Beam separation³⁾ • $0.5 \times \text{beam separation} + 3.5\text{ mm}$
Beam separation	2.5 mm, 5 mm, 10 mm, 20 mm, 25 mm, 30 mm, 50 mm
Number of beams	6 ... 510
Detection height	130 ... 3140 mm
Limiting range	2.8 m / 7 m / 12 m depending on device type ⁴⁾
Operating range	2 m / 5 m / 8.5 m depending on device type ⁵⁾
Minimum sensing range <ul style="list-style-type: none"> • With parallel-beam function • With cross-beam function 	<ul style="list-style-type: none"> • 0 mm • 0.2 ... 1.20 m (see table 123, page 147)
Initialization time after switch-on	<3 s
Response time	see "Response time and minimum presence time without high-speed scan", page 148
Minimum presence time	see "Minimum detectable absorption", page 150

Cycle time	8 ... 48 µs per beam ⁶⁾
------------	------------------------------------

- 1) Only possible for devices with < 240 beams.
- 2) For opaque objects. For transparent objects + 4 mm
- 3) For opaque objects. For transparent objects + 1 mm
- 4) In Dust- and sunlight-resistant operating mode depending on device type.
- 5) In Dust- and sunlight-resistant operating mode: 3 m / 5 m depending on device type.
- 6) Depending on device version and operating mode.

Table 123: Minimum sensing range with cross-beam function

MLG-2 with sensing range	Beam separation						
	2.5 mm	5 mm	10 mm	20 mm	25 mm	30 mm	50 mm
2 m	0.20 m	-	-	-	-	-	-
5 m	-	0.11 m	0.22 m	0.44 m	0.55 m	0.66 m	1.10 m
8.5 m	-	0.12 m	0.24 m	0.48 m	0.60 m	0.72 m	1.20 m

13.2 Fieldbus module data sheet

General data

Table 124: Fieldbus module data sheet – General data

Protection class	III (EN 61140)
Enclosure rating	IP 65 and IP 67 (EN 60529) ¹⁾
Ambient operating temperature	-30 ... +55 °C
Storage temperature	-40 ... +70 °C
Vibration resistance	5 g, 10 ... 55 Hz (EN 60068-2-6)
Shock resistance (EN 60068-2-27)	<ul style="list-style-type: none"> • Single shock • Continuous shock <ul style="list-style-type: none"> • 15 g, 11 ms • 10 g, 16 ms
Electromagnetic compatibility	According to EN 61000-6-2 Interference immunity for industrial environments and EN 61000-6-4 Emission standard for industrial environments
MTTF MTBF	15 years 15 years
Firmware version	See type label of device.
Dimensions	see "Dimensional drawing MLG-2 ProNet", page 151
Weight	350 g
Materials	<ul style="list-style-type: none"> • Housing <ul style="list-style-type: none"> • Zinc, painted

1) Do not use light grids outdoors without protection (condensation will form).

Electrical specifications (for 24 V DC and 25 °C ambient temperature)

Table 125: Fieldbus module data sheet – Electrical specifications

Supply voltage V_S	24 V DC \pm 20%
Residual ripple (within V_S)	< 10%
Current consumption	<ul style="list-style-type: none"> • Typical • Maximum <ul style="list-style-type: none"> • 115 mA • < 160 mA

Required overcurrent protection when using the following wire gages	
<ul style="list-style-type: none"> • AWG 20/0.52 mm² • AWG 22/0.32 mm² • AWG 24/0.20 mm² • AWG 26/0.13 mm² • AWG 28/0.08 mm² • AWG 30/0.05 mm² 	<ul style="list-style-type: none"> • 5 A • 3 A • 2 A • 1 A • 0.8 A • 0.5 A

Ethernet interface

Table 126: Fieldbus module data sheet – Ethernet interface

Data transmission rate	100 Mbit/s
Default IP address	192.168.200.100
Subnet mask	255.255.255.0
Protocol	TCP/IP
Maximum length of cable	According to IEE802.3 (typ. 100 m)

PROFIBUS interface

Table 127: Fieldbus module data sheet - PROFIBUS interface

Data transmission rate	Autobaud, 9,600 kbit/s to 12 Mbit/s
------------------------	-------------------------------------

13.3 Diagrams

13.3.1 Response time and minimum presence time without high-speed scan

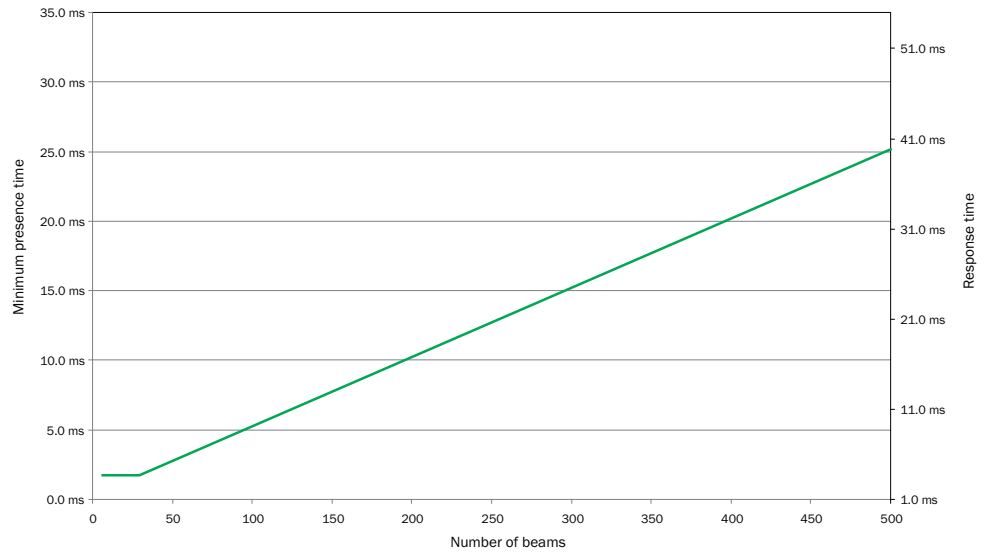

Figure 140: Graph, MLG-2 Pro response time and minimum presence time



NOTE

If the cross-beam function is configured, multiply the minimum presence time and the response time by 2.

13.3.2 Response time and minimum presence time during high-speed scan with 2,5 mm resolution

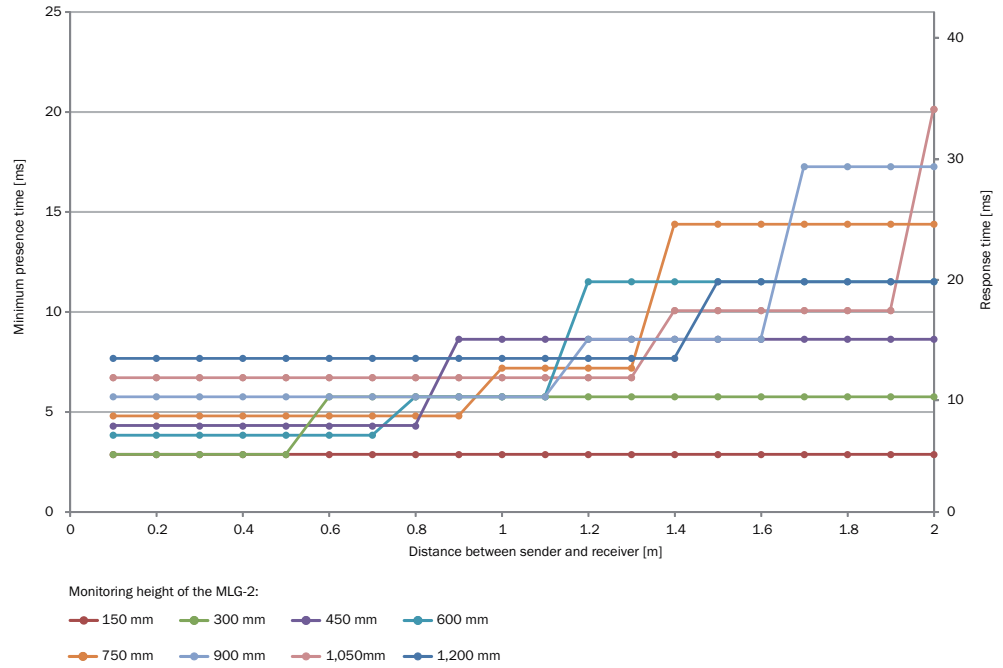

Figure 141: Response time and minimum presence time up to 2 m sensing range



NOTE

Only applies for the “High measurement accuracy” operating mode since only this operating mode can be set via the SDD, special for 2.5 mm raster devices.

13.3.3 Response time and minimum presence time during high-speed scan with up to 3.5 m sensing range

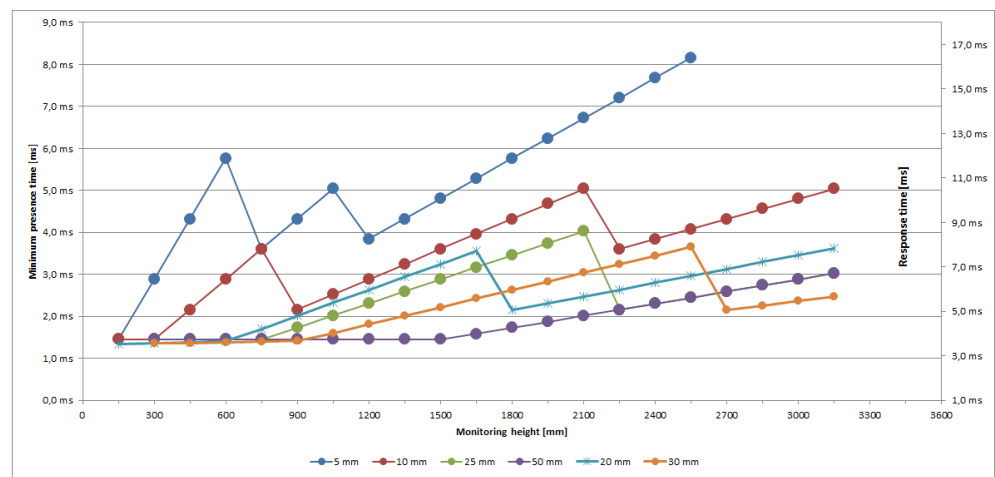

Figure 142: Response time and minimum presence time up to 3.5 m sensing range

13.3.4 Response time and minimum presence time during high-speed scan with up to 8.5 m sensing range

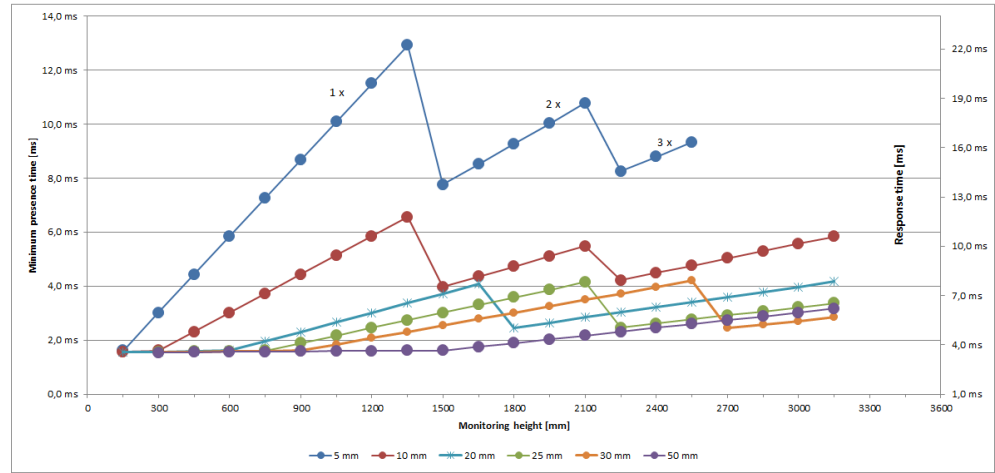

Figure 143: Response time and minimum presence time up to 8.5 m sensing range

13.3.5 Minimum detectable absorption

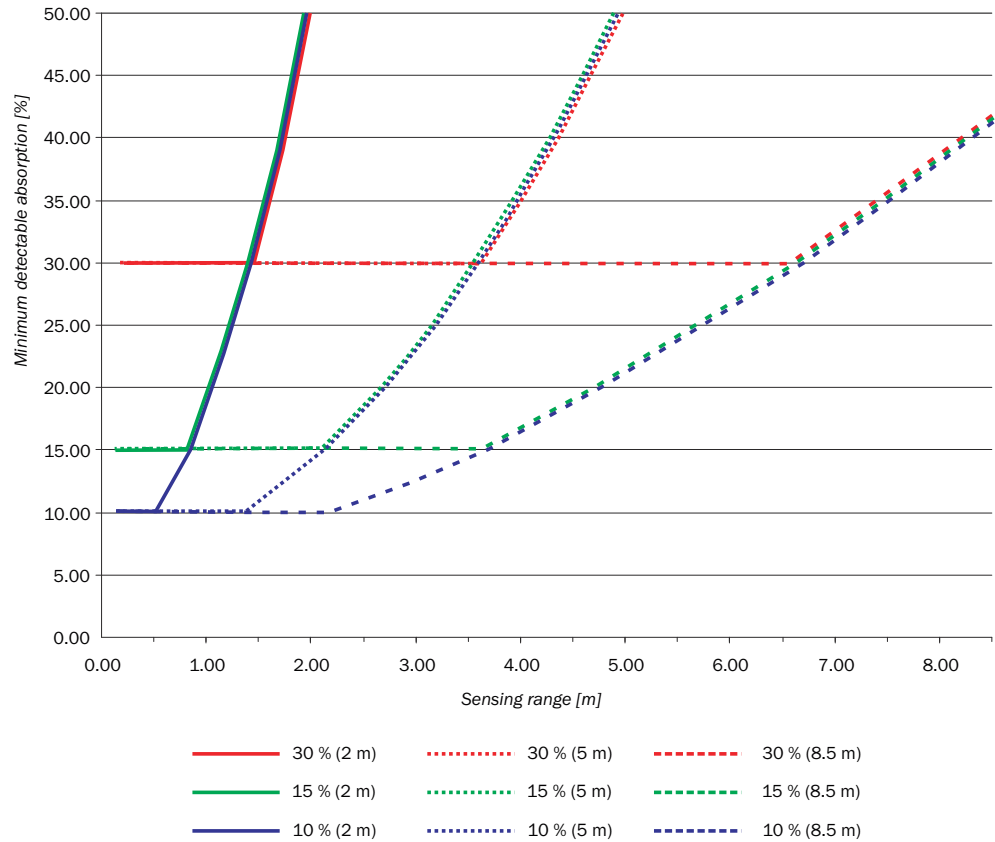

Figure 144: Minimum detectable absorption required for devices with 2 m, 5 m and 8.5 m sensing range



NOTE

The minimum detectable absorption which can be read from the diagram applies after the teach-in process with clean ambient conditions. The minimum detectable absorption increases with the level of contamination. Clean the front screens of the sender and receiver regularly, then perform a teach-in process.

13.4 Dimensional drawings

13.4.1 Dimensional drawing MLG-2 ProNet

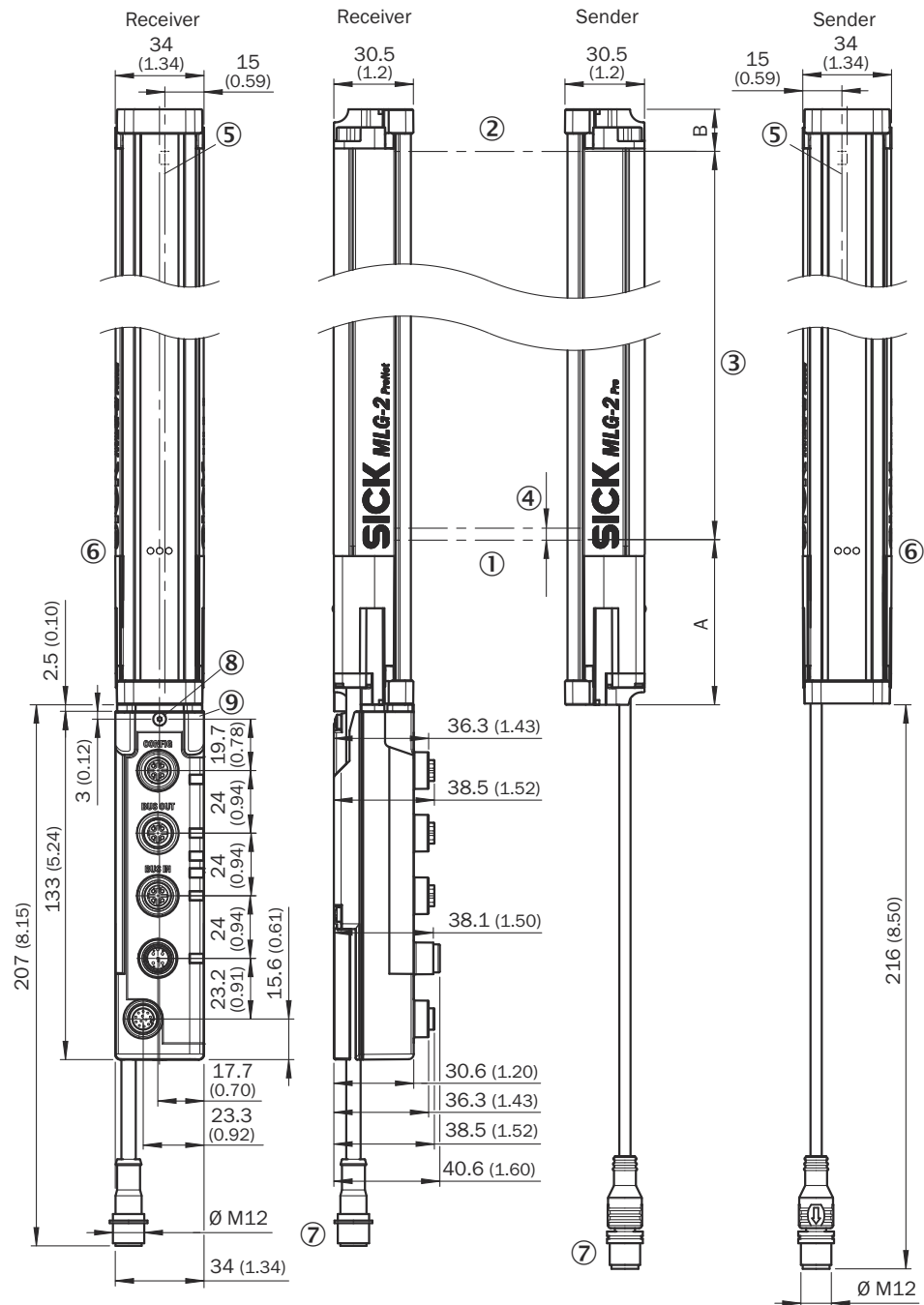

Figure 145: Dimensional drawing MLG-2 ProNet (mm)

① First light beam

- ② Last light beam
 - ③ Detection height (see table 128)
 - ④ Beam separation
 - ⑤ Optical axis
 - ⑥ Status indicator: green, yellow, red LEDs
 - ⑦ Connection
- A + B see table 129, page 153

Total height of the devices

Total height of the devices with 5, 10, 20, 25, 30 and 50 mm beam separation = A + ① + ④ + 16.1 mm (equates to ②).

Total height of the devices with 2.5 mm beam separation = A + ① + ④ + 17.15 mm (equates to ②).

13.4.2 Measurement tables

Table 128: Detection height (mm)/number of beams

	Type/beam separation						
	MLG02.../ 2.5 mm	MLG05.../ 5 mm	MLG10.../ 10 mm	MLG20.../ 20 mm	MLG25.../ 25 mm	MLG30.../ 30 mm	MLG50.../ 50 mm
Detection height [mm]/number of beams	145/59	145/30	140/15	140/8 ¹	-	-	-
	295/119	295/60	290/30	280/15 ²	275/12	270/10	250/6
	445/179	445/90	440/45	440/23 ¹	425/18	420/15	400/9
	595/239	595/120	590/60	580/30 ²	575/24	570/20	550/12
	745/299	745/150	740/75	740/38 ¹	725/30	720/25	700/15
	895/359	895/180	890/90	880/45 ²	875/36	870/30	850/18
	1045/419	1045/210	1040/105	1040/53 ¹	1025/42	1020/35	1000/21
	1195/479	1195/240	1190/120	1180/60 ²	1175/48	1170/40	1150/24
	-	1345/270	1340/135	1340/68 ¹	1325/54	1320/45	1300/27
	-	1495/300	1490/150	1480/75 ²	1475/60	1470/50	1450/30
	-	1645/330	1640/165	1640/83 ¹	1625/66	1620/55	1600/33
	-	1795/360	1790/180	1780/90 ²	1775/72	1770/60	1750/36
	-	1945/390	1940/195	1940/98 ¹	1925/78	1920/65	1900/39
	-	2095/420	2090/210	2080/105 ²	2075/84	2070/70	2050/42
	-	2245/450	2240/225	2240/113 ¹	2225/90	2220/75	2200/45
	-	2395/480	2390/240	2380/120 ²	2375/96	2370/80	2350/48
	-	2545/510	2540/255	2540/128 ¹	2525/102	2520/85	2500/51
	-	-	2690/270	2680/135 ²	2675/108	2670/90	2650/54
	-	-	2840/285	2840/143 ¹	2825/114	2820/95	2800/57
	-	-	2990/300	2980/150 ²	2975/120	2970/100	2950/60
-	-	3140/315	3140/158 ¹	3125/126	3120/105	3100/63	

¹ Distance from MLG-2 connection side to first beam = 68.3 mm.
² Distance from MLG-2 connection side to first beam = 78.3 mm.

Table 129: Distance from MLG-2 connection side to first beam

Beam separation	Distance from MLG-2 connection side to first beam (A)	Distance from MLG-2 connection side to last beam (B)
2.5 mm	62.25 mm	17.15 mm
5 mm	63.3 mm	16.1 mm
10 mm	68.3 mm	16.1 mm
20 mm	68.3 mm / 78.3 mm ¹	16.1 mm
25 mm	83.3 mm	16.1 mm
30 mm	88.3 mm	16.1 mm
50 mm	108.3 mm	16.1 mm

¹ see table 128.

13.4.3 Dimensional drawings for the MLG-2 fieldbus module

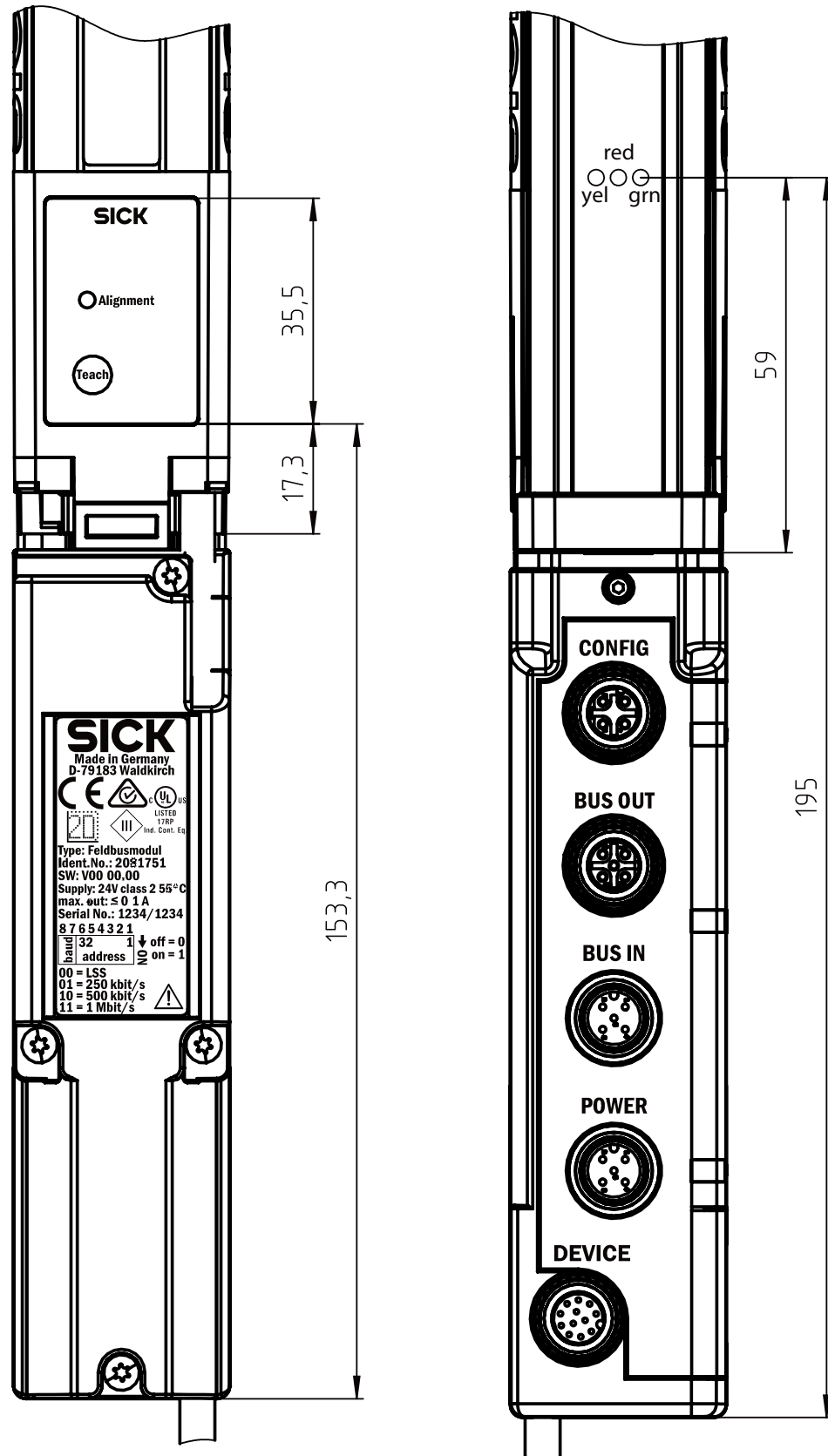

Figure 146: Dimensional drawing 1 MLG-2 fieldbus module

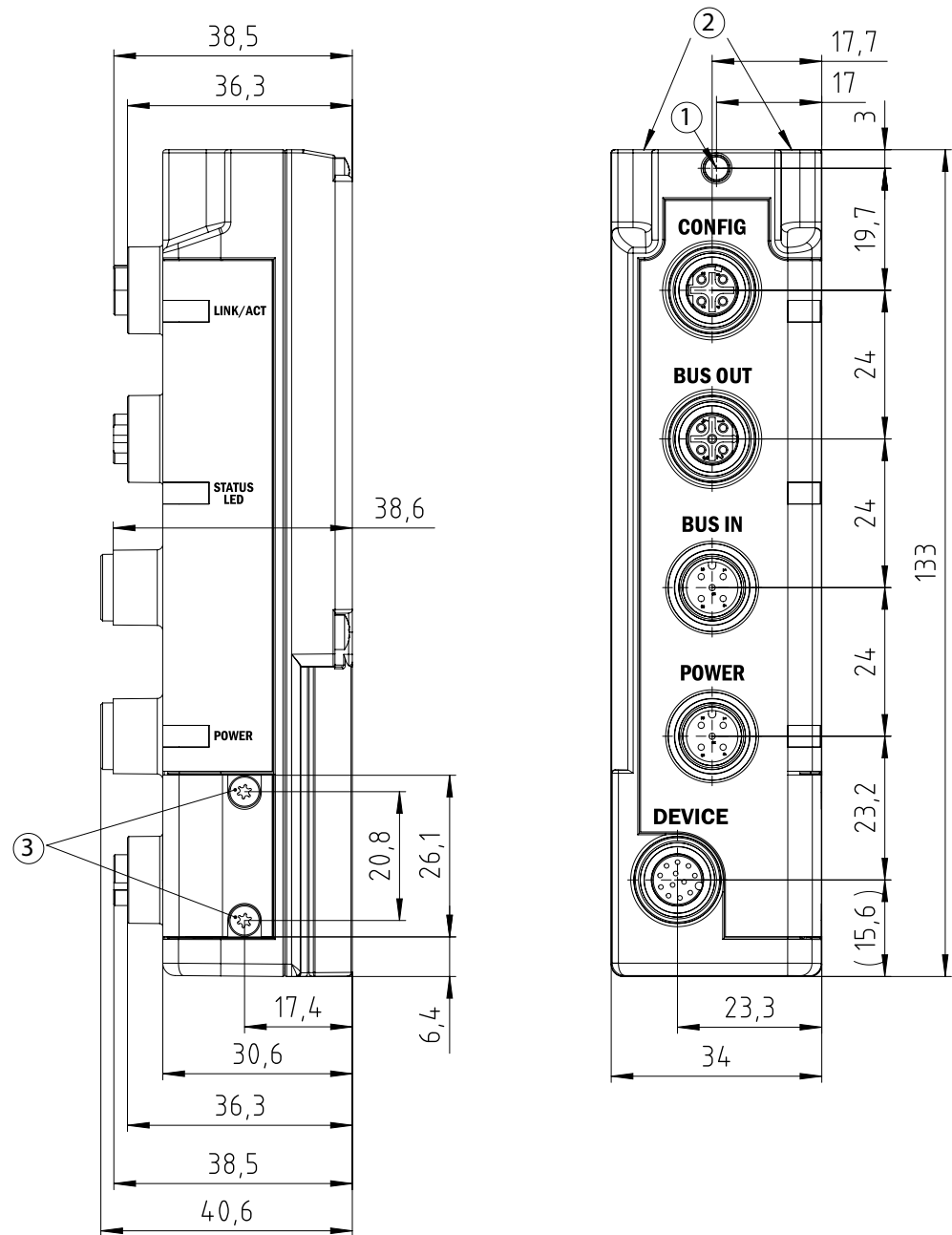

Figure 147: Dimensional drawing 2 MLG-2 fieldbus module

- ① Fieldbus module fixing screw
- ② Openings for mounting pins
- ③ DIP switch cover fixing screw

14 Ordering information

Ordering information for the MLG-2 can be found in the MLG-2 product information, SICK part number 8017054.

15 Accessories

15.1 Auxiliary equipment

Table 130: Equipment part numbers

Type	Description	Part no.
AR60	Laser alignment aid for various sensors, laser class 2 (IEC 60825). Do not look into the beam.	1015741
Adapter AR60	Adapter AR60 for MLG-2	4070854
Lens cloth	Cloth for cleaning the front screen	4003353
Plastic cleaner	Plastic cleaner and polish, anti-static, 0.5 liters	5600006

15.2 Mounting materials

Table 131: Mounting material part numbers

Type	Description	Part no.
BEF-1SHABP004	Mounting kit for replacement of swivel mount brackets 2019649 and 2019659 or side bracket 2019506 with the FlexFix bracket when using the bore holes provided	2071021
BEF-1SHABPKU4	FlexFix bracket, plastic	2066614
BEF-1SHABPKU4-SET2	Set with 4 × FlexFix bracket, plastic and 1 × mounting bracket	2083452
BEF-3SHABPKU2	QuickFix bracket, plastic	2066048
BEF-3SHABPKU2-SET1	Set with 6 × QuickFix bracket, plastic	2085604
BEF-WN-FBM-SET1	1 × mounting bracket and 1 × screw M5 × 6	2082322
BEF-WN-FBM-SET2	2 × mounting bracket and 3 × screw M5 × 6	2083323

Table 132: Sliding nut part numbers

Type	Description	Part no.
T-nuts	Sliding nut	4031411
Sliding nut	Sliding nut, M5	5305719
Sliding nuts	Sliding nut set, M5, 4 pieces	2017550
UH sliding nut	Sliding nut, item profile, M6	5305615

15.3 Connection materials

Table 133: T-connector part numbers

Type	Description	Part no.
SBO-02G12-SM	T-connector M12, 5-pin, male connector M12, 5-pin, straight, A-coded on 2 × female connector M12, 5-pin, straight, A-coded	6029305

Table 134: Part numbers for connecting cable with female connector

Type	Head A connection type	Head B connection type	Connecting cable	Part no.
DOL-1205-G05MAC	Female connector, M12, 5-pin, straight, shielded	Cable, loose cable ends	5 m, 5-wire	6036384

Type	Head A connection type	Head B connection type	Connecting cable	Part no.
DOL-1205-G02M	Female connector, M12, 5-pin, straight, unshielded	Cable, loose cable ends	2 m, 5-wire	6008899
DOL-1205-G05M			5 m, 5-wire	6009868
DOL-1205-G10M			10 m, 5-wire	6010544
DOL-1205-G15M			15 m, 5-wire	6029215

Table 135: Female and male connector part numbers

Type	Head A connection type	Head B connection type	Part no.
DOS-1205-G	Female connector, M12, 5-pin, straight, unshielded	Screw terminals	6009719

Table 136: Ethernet connecting cable part numbers (configuration)

Type	Head A connection type	Head B connection type	Connecting cable	Part no.
SSL-1204-G02ME	Male connector, M12, 4-pin, D-coded, shielded	Male connector, M12, 4-pin, D-coded	2 m, 4-wire	6034420
SSL-1204-G05ME			5 m, 4-wire	6034422
Connection cable (male connector-male connector)	Male connector, M12, 4-pin, straight, D-coded, shielded	Male connector, RJ-45, 8-pin, straight	5 m, 4-wire, AWG26	6034415
SSL-2J04-G02ME	Male connector, M12, 4-pin, straight, D-coded, shielded	Male connector, RJ-45, 8-pin, straight	2 m, 4-wire, AWG26	6034414

Table 137: PROFIBUS connecting cable part numbers

Type	Head A connection type	Head B connection type	Connecting cable	Part no.
DSL-1205-G01MC	Female connector, M12, 5-pin, straight, A-coded	Male connector, M12, 5-pin, straight, A-coded	1 m, 5-wire, 0.34 mm ²	6029280
DSL-1205-G05MC			5 m, 5-wire, 0.34 mm ²	6029282
DSL-1205-G10MC			10 m, 5-wire, 0.34 mm ²	6038954
DOL-1205-G05MQ	Female connector, M12, 5-pin, straight	Open cable ends	5 m, 5-wire, 0.34 mm ²	6026006
DOL-1205-G10MQ	Female connector, M12, 5-pin, straight	Open cable ends	10 m, 5-wire, 0.34 mm ²	6026008
DOS-1205-GA	Female connector, M12, 5-pin, straight	Female cable connector		6027534
STE-1205-GA	Male connector, M12, 5-pin, straight	Male cable connector		6028333
PR-STE-END	Male connector, M12, 5-pin, straight	PROFIBUS terminator, M12, B-coded		6021156

Type	Head A connection type	Head B connection type	Connecting cable	Part no.
LTG-2804-MW	Cable sold by the meter, AL PT, shielded, PUR halogen-free, black			6028328

Table 138: Part number for MLG-2 connection cable to fieldbus module

Type	Head A connection type	Head B connection type	Connecting cable	Part no.
DSL-1212-G2M7AC	Female connector, M12, 12-pin, straight	Male connector, M12, 12-pin, straight	2.7 m, 12-wire, shielded, PUR, halogen-free	6056903

16 Annex

16.1 Conformities and certificates

You can obtain declarations of conformity, certificates and the current documentation for the product at www.sick.com. To do so, enter the product part number in the search field (part number: see the entry in the “P/N” or “Ident. no.” field on the type label).

16.2 Licenses

SICK uses open source software which is published by the rights holders under a free license. Among others, the following license types are used: GNU General Public License (GPL version 2, GPL version 3), GNU Lesser General Public License (LGPL), MIT license, zlib license and licenses derived from the BSD license.

This program is provided for general use without warranty of any kind. This warranty disclaimer also extends to the implicit assurance of marketability or suitability of the program for a particular purpose.

More details can be found in the GNU General Public License.

For license texts see www.sick.com/licensetexts.

License texts can be read out from the device using a web browser via the following URL: `<device ip>/license/COPYING`

Printed copies of the license texts are also available on request.

17 List of figures

1.	MLG-2 ProNet device components.....	14
2.	Detection area of the MLG-2.....	15
3.	Schematic depiction of available beam separations (mm).....	15
4.	Detection area with beams blanked.....	17
5.	Standard scan method.....	18
6.	Scan time in relation to the number of beams.....	18
7.	Cross-beam function.....	19
8.	High-speed scan.....	19
9.	Scan time in relation to the number of beams when using the high-speed scan..	19
10.	Minimum detectable object.....	20
11.	Minimum detectable object length.....	21
12.	Cross-beam function.....	22
13.	Minimum detectable object size with high measurement accuracy.....	23
14.	LEDs on the sender.....	31
15.	LEDs on the front and on the control panel.....	32
16.	Control panel on the rear side.....	32
17.	LEDs on the fieldbus module	33
18.	DIP switch on the fieldbus module.....	33
19.	Start and end detection.....	34
20.	Detection of transparent objects.....	34
21.	Detection of small objects.....	34
22.	Traffic applications.....	34
23.	Volume measurement.....	34
24.	Contour measurement.....	34
25.	Placement with light in opposite directions.....	35
26.	Distances when light is in the same direction.....	36
27.	Graph, distances when light is in the same direction.....	37
28.	Graph, distances when light is in the same direction (XZ).....	38
29.	Placement of two light grids at right angles.....	38
30.	Graph, minimum distance from reflective surfaces.....	39
31.	The sender and receiver are aligned incorrectly.....	40
32.	Mount QuickFix bracket to a profile frame.....	41
33.	QuickFix bracket for the fieldbus module.....	42
34.	Mounting the FlexFix bracket on a profile frame.....	43
35.	Inserting the MLG-2 in the FlexFix brackets.....	43
36.	Mounting bracket for the fieldbus module	44
37.	Mounting directions of the fieldbus module	45
38.	Turn the fieldbus module by 180°	45
39.	Mount the fieldbus module offset using the QuickFix bracket.....	46
40.	Mount the fieldbus module offset using the mounting bracket.....	46
41.	Fieldbus module connections.....	48
42.	Connection to the PROFIBUS fieldbus.....	51
43.	T-connector for sender and fieldbus module.....	53
44.	Alignment with the QuickFix bracket.....	54
45.	Alignment with the FlexFix bracket.....	55
46.	Rotate the receiver once.....	55
47.	Control panel.....	56
48.	Example of PROFIBUS network in a bus structure (line).....	57
49.	DIP switches 1 ... 8.....	59
50.	Address configuration in SOPAS ET.....	60
51.	Beam function NBB.....	64
52.	Beam function NBM.....	64
53.	Beam function FBB.....	65
54.	Beam function FBM.....	65

55. Beam function LBB.....66

56. Beam function LBM..... 66

57. Beam function NCBB.....67

58. Beam function NCBM..... 67

59. Beam function CBB..... 68

60. Beam function CBM.....68

61. Beam function ODI..... 69

62. Beam function IDI..... 69

63. Beam status – Example 1.....70

64. Beam status – Example 2.....71

65. Example of the blanking of blocked beams..... 79

66. Example of blanking made beams..... 80

67. Bit-coded beam mask for an MLG-2, with 30 beams.....80

68. Beam numbering..... 87

69. Device selection, operating mode and user level.....94

70. SOPAS ET interface.....95

71. Display of the system boundaries..... 95

72. Wizards..... 96

73. Display of the process quality..... 96

74. Basic functions and status of the output.....97

75. Detection area – Simulation..... 97

76. Combining beams into zones.....98

77. Using beams for object recognition.....98

78. Using beams for height classification..... 99

79. Using beams to classify the object position.....99

80. Blanking beams.....100

81. Blanked beams.....100

82. Rotating the image of the MLG-2..... 100

83. Image of the MLG-2 rotated.....101

84. Expandable menus for configuration..... 101

85. Effect of the output configuration on the status indicator..... 102

86. Effects of the performance options on the system boundaries.....102

87. I/O configuration..... 103

88. Beam numbering.....104

89. Address configuration in SOPAS ET..... 105

90. Example representation of the outer dimension.....106

91. Settings for height classification..... 107

92. Setting the height with the mouse..... 107

93. Beams highlighted in color in the simulation..... 108

94. Object recognition, static..... 109

95. Object recognition, dynamic..... 109

96. Object recognition with tolerance.....110

97. Object detection/object width..... 111

98. Setting the object size with the mouse..... 111

99. Object detection of consecutive objects..... 112

100. Hole detection/hole size..... 113

101. Setting the hole size with the mouse..... 113

102. Detection of consecutive beams..... 114

103. Measurement of the outside dimension..... 115

104. Measurement of the inside dimension..... 115

105. Setting the outside dimension with the mouse.....115

106. Classification of the object position – object center is greater than or equal to n beam..... 116

107. Classification of the object position – object center is smaller than or equal to n beam..... 116

108. Classification of the object position – object center is equal to n beam..... 117

109. Setting the object position with the mouse..... 117

110. Classification of the hole position – larger than or equal to hole center.....	118
111. Classification of the hole position – smaller than or equal to hole center.....	118
112. Classification of the hole position – equal to hole center.....	118
113. Setting the hole position with the mouse.....	119
114. Examples of the effect of a configured minimum pulse width.....	120
115. Measuring within zones.....	121
116. SOPAS ET beam window – Combining beams into zones.....	121
117. SOPAS ET – Assigning an application and zone to an output.....	122
118. Teach-in successful.....	123
119. Teach-in failed.....	123
120. Teach-in quality.....	123
121. Example of the blanking of blocked beams.....	124
122. Example of blanking made beams.....	124
123. Performance options for Standard operating mode and Dust- and sunlight-resist- ant operating mode.....	125
124. Performance options for Transparent operating mode.....	126
125. Illustration of the measuring object.....	128
126. Left: “Cross beam switching”, right: “Cross beam measuring”.....	128
127. SOAPS ET – Activating cross beam switching mode.....	129
128. SOAPS ET – Activating cross beam measuring mode.....	130
129. SOAPS ET, beam window – “Cross beam measuring” display.....	130
130. SOPAS ET – “Blocked Beams Hold (BBH)” function.....	132
131. SOPAS ET – “Lost Beams Hold (LBH)” function.....	133
132. Add simulation object.....	134
133. Determine the shape of the simulation object.....	134
134. Determine the size of the simulation object.....	134
135. Start simulation.....	135
136. Simulation object in Simulation area.....	135
137. Beam status.....	135
138. Function programming.....	137
139. Interface of the integrated web server.....	140
140. Graph, MLG-2 Pro response time and minimum presence time.....	148
141. Response time and minimum presence time up to 2 m sensing range.....	149
142. Response time and minimum presence time up to 3.5 m sensing range.....	149
143. Response time and minimum presence time up to 8.5 m sensing range.....	150
144. Minimum detectable absorption required for devices with 2 m, 5 m and 8.5 m sensing range.....	150
145. Dimensional drawing MLG-2 ProNet (mm).....	151
146. Dimensional drawing 1 MLG-2 fieldbus module.....	154
147. Dimensional drawing 2 MLG-2 fieldbus module.....	155

18 List of tables

1.	Authorized personnel.....	9
2.	Example of an MLG-2 ProNet type code.....	11
3.	Meaning of the positions in the type code.....	11
4.	Monitoring height [mm].....	12
5.	Sensing range and minimum detectable object length.....	12
6.	Preconfiguration of MLG-2 ProNet with fieldbus version P.....	12
7.	Maximum monitoring heights.....	16
8.	Limiting range.....	16
9.	Minimum detectable object in relation to the beam separation of the MLG-2.....	20
10.	Minimum detectable object length with the MLG-2.....	21
11.	Minimum detectable object with cross-beam function on the MLG-2.....	22
12.	Minimum detectable object size with high measurement accuracy.....	23
13.	Minimum detectable object length with high measurement accuracy.....	23
14.	Functions available for or during teach-in.....	26
15.	Functions available for operating modes and performance options.....	26
16.	Configurable measuring and diagnostic functions for switching output Q1.....	27
17.	Auxiliary resources and diagnostic options.....	27
18.	System information.....	28
19.	Beam evaluation.....	28
20.	Settings for the interfaces.....	29
21.	Settings for SOPAS ET.....	29
22.	Available process data.....	29
23.	Application examples for the MLG-2.....	34
24.	Overcurrent protection.....	47
25.	Pin assignment, MLG-2 fieldbus connection box, CONFIG.....	48
26.	Pin assignment, MLG-2 fieldbus connection box, BUS OUT.....	49
27.	Pin assignment, MLG2 fieldbus connection box, BUS IN.....	49
28.	Pin assignment, MLG2 fieldbus connection box, POWER.....	49
29.	Pin assignment, sender connection.....	50
30.	Pin assignment, I/O connection of the T-connector.....	53
31.	Value of the DIP switches.....	59
32.	Nomenclature for access and data types.....	60
33.	Process data indexes.....	61
34.	Indexes for teach-in.....	62
35.	Indexes for defining operating mode/performance options.....	62
36.	Indexes with auxiliary resources and diagnostic options.....	62
37.	Indexes with system information.....	63
38.	Indexes with beam evaluation.....	63
39.	Compatibility modules	63
40.	NBB.....	64
41.	NBM.....	64
42.	FBB.....	64
43.	FBM.....	65
44.	LBB.....	66
45.	LBM.....	66
46.	NCBB.....	67
47.	NCBM.....	67
48.	CBB.....	68
49.	CBM.....	68
50.	ODI.....	68
51.	IDI.....	69
52.	RLC – Run-length code.....	69
53.	Example run-length code with 30 beams.....	70
54.	Example run-length code with the first beam blocked.....	70

55. Beam status.....	70
56. Beam functions for Zone measuring.....	71
57. User defined.....	72
58. QS – Switching output status.....	73
59. SYS – System status.....	73
60. Details of the system status.....	73
61. QoR – Quality of Run.....	73
62. QoT – Quality of Teach (teach-in quality).....	74
63. Control.....	74
64. Details.....	74
65. Beam status.....	75
66. NBB.....	75
67. NBM.....	75
68. FBB.....	75
69. FBM.....	75
70. LBB.....	76
71. LBM.....	76
72. NCBB.....	76
73. NCBM.....	76
74. CBB.....	76
75. CBM.....	76
76. ODI.....	76
77. IDI.....	76
78. Teach-in.....	77
79. Teach-in result.....	78
80. Teach-in result – Stored in 8 bit.....	78
81. Teach-in required.....	78
82. Teach-in with blanking.....	78
83. Blank blocked beams.....	79
84. Blank beams made.....	79
85. Beam mask.....	80
86. Operating mode.....	81
87. Performance options.....	81
88. Minimum detectable absorption.....	82
89. Configuration Q1.....	82
90. Byte sequence of 63h.....	82
91. Selectable beam functions.....	83
92. Energy saving mode.....	85
93. Switch-off delay.....	85
94. Alignment aid.....	85
95. Values for alignment aid.....	86
96. “Find Me” function.....	86
97. Pushbutton lock.....	86
98. Beam numbering.....	86
99. Factory settings.....	87
100. Cloning upload.....	88
101. Cloning download.....	88
102. Cloning status.....	88
103. Device name.....	89
104. Manufacturer name.....	89
105. Part number.....	89
106. Serial number.....	89
107. Product text.....	89
108. Mounting location.....	89
109. Device characteristics.....	90
110. Hardware revision.....	90
111. Firmware version	90

112. Zone measuring..... 91

113. Cross beam measuring..... 91

114. Evaluation mode..... 91

115. Beam functions for preliminary evaluation.....138

116. LED indicators on the sender..... 142

117. LED indicators on the receiver..... 142

118. LEDs on the fieldbus module..... 143

119. MLG-2 data sheet – General data..... 145

120. MLG-2 data sheet – Electrical specifications..... 145

121. MLG-2 data sheet – Switching outputs.....146

122. MLG-2 data sheet – Technical measurement specifications..... 146

123. Minimum sensing range with cross-beam function..... 147

124. Fieldbus module data sheet – General data.....147

125. Fieldbus module data sheet – Electrical specifications..... 147

126. Fieldbus module data sheet – Ethernet interface..... 148

127. Fieldbus module data sheet - PROFIBUS interface.....148

128. Detection height (mm)/number of beams.....152

129. Distance from MLG-2 connection side to first beam..... 153

130. Equipment part numbers.....157

131. Mounting material part numbers..... 157

132. Sliding nut part numbers..... 157

133. T-connector part numbers..... 157

134. Part numbers for connecting cable with female connector..... 157

135. Female and male connector part numbers.....158

136. Ethernet connecting cable part numbers (configuration)..... 158

137. PROFIBUS connecting cable part numbers..... 158

138. Part number for MLG-2 connection cable to fieldbus module..... 159

Australia

Phone +61 (3) 9457 0600
1800 33 48 02 – tollfree
E-Mail sales@sick.com.au

Austria

Phone +43 (0) 2236 62288-0
E-Mail office@sick.at

Belgium/Luxembourg

Phone +32 (0) 2 466 55 66
E-Mail info@sick.be

Brazil

Phone +55 11 3215-4900
E-Mail comercial@sick.com.br

Canada

Phone +1 905.771.1444
E-Mail cs.canada@sick.com

Czech Republic

Phone +420 234 719 500
E-Mail sick@sick.cz

Chile

Phone +56 (2) 2274 7430
E-Mail chile@sick.com

China

Phone +86 20 2882 3600
E-Mail info.china@sick.net.cn

Denmark

Phone +45 45 82 64 00
E-Mail sick@sick.dk

Finland

Phone +358-9-25 15 800
E-Mail sick@sick.fi

France

Phone +33 1 64 62 35 00
E-Mail info@sick.fr

Germany

Phone +49 (0) 2 11 53 010
E-Mail info@sick.de

Greece

Phone +30 210 6825100
E-Mail office@sick.com.gr

Hong Kong

Phone +852 2153 6300
E-Mail ghk@sick.com.hk

Hungary

Phone +36 1 371 2680
E-Mail ertesites@sick.hu

India

Phone +91-22-6119 8900
E-Mail info@sick-india.com

Israel

Phone +972 97110 11
E-Mail info@sick-sensors.com

Italy

Phone +39 02 27 43 41
E-Mail info@sick.it

Japan

Phone +81 3 5309 2112
E-Mail support@sick.jp

Malaysia

Phone +603-8080 7425
E-Mail enquiry.my@sick.com

Mexico

Phone +52 (472) 748 9451
E-Mail mexico@sick.com

Netherlands

Phone +31 (0) 30 229 25 44
E-Mail info@sick.nl

New Zealand

Phone +64 9 415 0459
0800 222 278 – tollfree
E-Mail sales@sick.co.nz

Norway

Phone +47 67 81 50 00
E-Mail sick@sick.no

Poland

Phone +48 22 539 41 00
E-Mail info@sick.pl

Romania

Phone +40 356-17 11 20
E-Mail office@sick.ro

Russia

Phone +7 495 283 09 90
E-Mail info@sick.ru

Singapore

Phone +65 6744 3732
E-Mail sales.gsg@sick.com

Slovakia

Phone +421 482 901 201
E-Mail mail@sick-sk.sk

Slovenia

Phone +386 591 78849
E-Mail office@sick.si

South Africa

Phone +27 10 060 0550
E-Mail info@sickautomation.co.za

South Korea

Phone +82 2 786 6321/4
E-Mail infokorea@sick.com

Spain

Phone +34 93 480 31 00
E-Mail info@sick.es

Sweden

Phone +46 10 110 10 00
E-Mail info@sick.se

Switzerland

Phone +41 41 619 29 39
E-Mail contact@sick.ch

Taiwan

Phone +886-2-2375-6288
E-Mail sales@sick.com.tw

Thailand

Phone +66 2 645 0009
E-Mail marcom.th@sick.com

Turkey

Phone +90 (216) 528 50 00
E-Mail info@sick.com.tr

United Arab Emirates

Phone +971 (0) 4 88 65 878
E-Mail contact@sick.ae

United Kingdom

Phone +44 (0)17278 31121
E-Mail info@sick.co.uk

USA

Phone +1 800.325.7425
E-Mail info@sick.com

Vietnam

Phone +65 6744 3732
E-Mail sales.gsg@sick.com

Detailed addresses and further locations at www.sick.com