

ENGLISH

**Photoelectric Proximity Sensor**  
with visible redlight (Laser)  
**Operating Instructions**

For laser class 1 devices:

For laser class 2 devices:

<b>LASER CLASS 1</b>	
	<b>Laser 1</b>
EN/IEC 60825-1:2014	
Maximum pulse power < 2,5 mW Puls length: 4 µs Wavelength: 650 - 670 nm	
Complies with 21 CFR 1040.10 and 1040.11 except for deviations pursuant to Laser Notice No. 56, dated May 08, 2019	

<b>Laser Radiation</b> <b>DO NOT STARE INTO BEAM</b> <b>CLASS 2 LASER PRODUCT</b>	
	<b>Laser 2</b>
EN/IEC 60825-1:2014	
Maximum pulse power < 5,0 mW Puls length: 4 µs Wavelength: 650 - 670 nm	
Complies with 21 CFR 1040.10 and 1040.11 except for deviations pursuant to Laser Notice No. 56, dated May 08, 2019	

**Safety notes**

- Not a safety component in accordance with EU Machinery Directive.
- Read the operating instructions before commissioning.
- Connection, mounting, and setting is only to be performed by trained specialists.
- When commissioning, protect the device from moisture and contamination.
- UL: The device shall be supplied from an isolating transformer having a secondary overcurrent protective device that complies with UL 248 to be installed in the field rated either:
  - a) max 5 amps for voltages 0 ~ 20 V (0 ~ 28.3 V peak), or
  - b) 100 / Vp for voltages of 20 ~ 30 V (28.3 ~ 42.4 V peak).
 Alternatively, they can be supplied from a Class 2 power supply.
- UL Environmental Rating: Enclosure type 1.

**Correct use**

The WTB9L-3 photoelectric proximity sensor is an opto-electronic sensor for the optical, non-contact detection of objects.

**Starting Operation**

Fit the sensor in a suitable bracket. Suitable mounting brackets can be found in the SICK accessories range, for example.

If using a plug version, connect the sensor to a cable socket without switching on the mains. If using a sensor with a connecting cable, connect the cables without switching on the power. The PIN / cable laying can be found in Diagram B (BN = brown, BU = blue, BK = black, WH = white). Then switch the operating voltage on.

**Setting sensing distance:**

Check the maximum scanning distance and reflectivity of the objects being scanned as well as the background. Note direction of object movement relative to sensor. Turn rotary knob to max. Position object. Align light spot onto the object to be probed. The light receiver display comes on.

If the light receiver display does not come on or just flashes, readjust the light scanner, clean it or check the application conditions.

The light receiver indicator must go out when the object is removed.

If the light receiver indicator continues to light up or flashes, the background influence is too great. If this is the case, reduce the sensing distance using the rotary knob until the receive indicator goes out or check the application conditions.

PNP (Load → M): object detected, output (Q) HIGH  
NPN (Load → L+): object detected, output (Q) LOW  
Q inverted

**Maintenance**

SICK light barriers are maintenance-free.  
We recommend doing the following regularly:  
- clean the external lens surfaces  
- check the screw connections and plug-in connections.

No modifications may be made to devices.

# SICK

8015315.1D5Y 0322 COMAT

## WTB9L-3

<b>Australia</b> Phone +61 (3) 9457 0600 1800 33 48 02 - tollfree	<b>Netherlands</b> Phone +31 (0) 30 229 25 44
<b>Austria</b> Phone +43 (0) 2236 62288-0	<b>New Zealand</b> Phone +64 9 415 0459 0800 222 278 - tollfree
<b>Belgium/Luxembourg</b> Phone +32 (0) 2 466 55 66	<b>Norway</b> Phone +47 67 81 50 00
<b>Brazil</b> Phone +55 11 3215-4900	<b>Poland</b> Phone +48 22 539 41 00
<b>Canada</b> Phone +1 905.771.1444	<b>Romania</b> Phone +40 356-17 11 20
<b>Czech Republic</b> Phone +420 234 719 500	<b>Russia</b> Phone +7 495 283 09 90
<b>China</b> Phone +86 20 2882 3600	<b>Singapore</b> Phone +65 6744 3732
<b>Denmark</b> Phone +45 45 82 64 00	<b>Slovakia</b> Phone +421 482 901 201
<b>Finland</b> Phone +358-9-25 15 800	<b>Slovenia</b> Phone +386 591 78849
<b>France</b> Phone +33 1 64 62 35 00	<b>South Africa</b> Phone +27 10 060 0550
<b>Germany</b> Phone +49 (0) 2 11 53 010	<b>South Korea</b> Phone +82 2 786 6321/4
<b>Greece</b> Phone +30 210 6825100	<b>Sweden</b> Phone +46 10 110 10 00
<b>Hong Kong</b> Phone +852 2153 6300	<b>Switzerland</b> Phone +41 41 619 29 39
<b>Hungary</b> Phone +36 1 371 2680	<b>Taiwan</b> Phone +886-2-2375-6288
<b>India</b> Phone +91-22-6119 8900	<b>Thailand</b> Phone +66 2 645 0009
<b>Israel</b> Phone +972 97110 11	<b>Turkey</b> Phone +90 (216) 528 50 00
<b>Italy</b> Phone +39 02 27 43 41	<b>United Arab Emirates</b> Phone +971 (0) 4 88 65 878
<b>Japan</b> Phone +81 3 5309 2112	<b>United Kingdom</b> Phone +44 (0)17278 31121
<b>Malaysia</b> Phone +603-8080 7425	<b>USA</b> Phone +1 800.325.7425
<b>Mexico</b> Phone +52 (472) 748 9451	<b>Vietnam</b> Phone +65 6744 3732

SICK AG, Erwin-Sick-Strasse 1, DE-79183 Waldkirch  
Detailed addresses and further locations at [www.sick.com](http://www.sick.com)

More representatives and agencies at [www.sick.com](http://www.sick.com) · Subject to change without notice · The specified product features and technical data do not represent any guarantee.

Weitere Niederlassungen finden Sie unter [www.sick.com](http://www.sick.com) · Irrtümer und Änderungen vorbehalten · Angegebene Produkteigenschaften und technische Daten stellen keine Garantieerklärung dar.

Plus de représentations et d'agences à l'adresse [www.sick.com](http://www.sick.com) · Sujet à modification sans préavis · Les caractéristiques de produit et techniques indiquées ne constituent pas de déclaration de garantie.

Para mais representantes e agências, consulte [www.sick.com](http://www.sick.com) · Alterações poderão ser feitas sem prévio aviso · As características do produto e os dados técnicos apresentados não constituem declaração de garantia.

Altri rappresentanti ed agenzie si trovano su [www.sick.com](http://www.sick.com) · Contenuti soggetti a modifiche senza preavviso · Le caratteristiche del prodotto e i dati tecnici non rappresentano una dichiarazione di garanzia.

Más representantes y agencias en [www.sick.com](http://www.sick.com) · Sujeto a cambio sin previo aviso · Las características y los datos técnicos especificados no constituyen ninguna declaración de garantía.

欲了解更多代表机构和代理商信息，请登录 [www.sick.com](http://www.sick.com) · 如有更改，不另行通知 · 对所给出的产品特性和技术参数的正确性不予保证。

その他の営業所は[www.sick.com](http://www.sick.com) よりご覧ください · 予告なしに変更されることがあります · 記載されている製品機能および技術データは保証を明示するものではありません。

**A** WTB9L-3xxxx

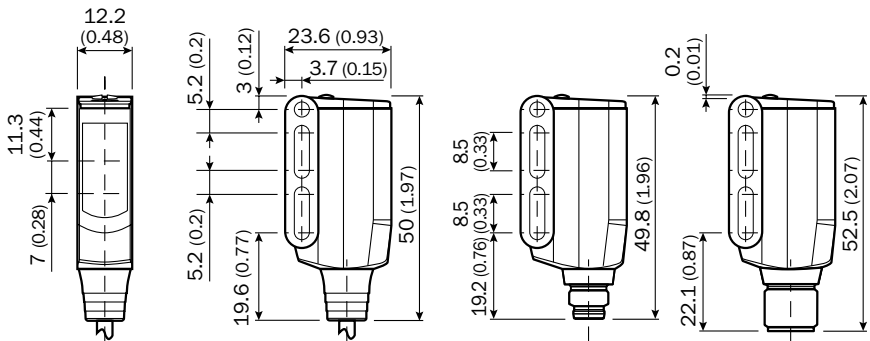

**B** WTB9M4L-3xxxx

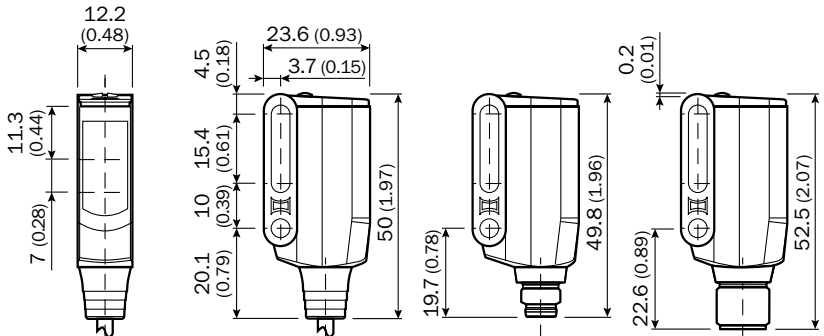

**B** WTB9xxL-3P1xxx

WTB9xxL-3N1xxx

WTB9xxL-3P22xx

WTB9xxL-3N22xx

WTB9xxL-3P24xx

WTB9xxL-3N24xx

WTB9xxL-3P3xxx

WTB9xxL-3N3xxx

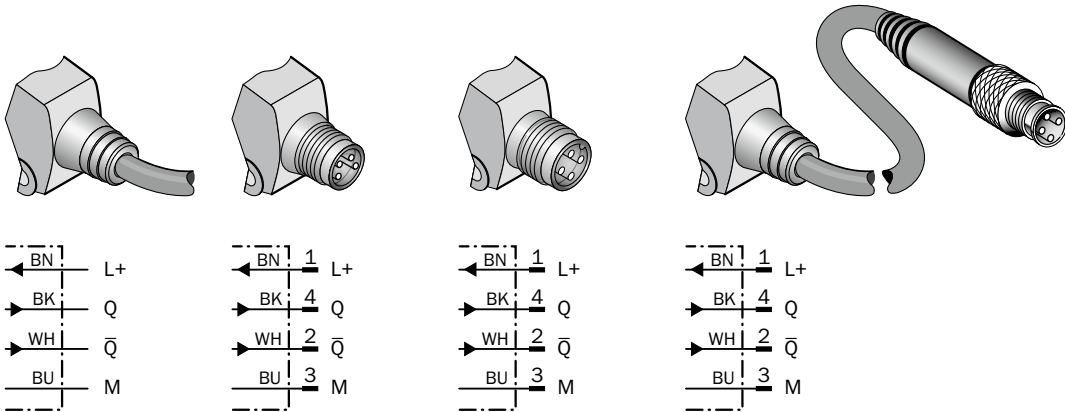

**1**

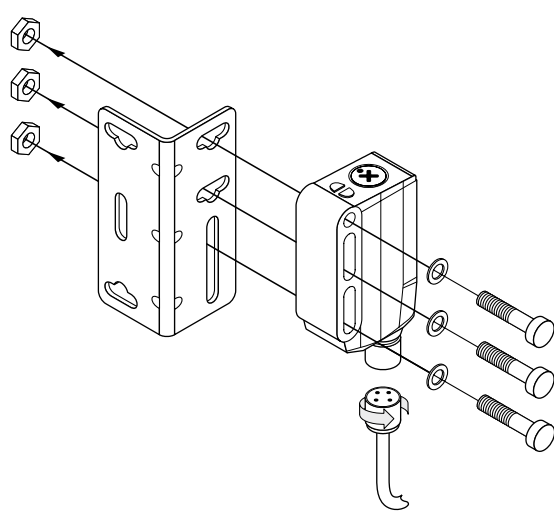

**3**

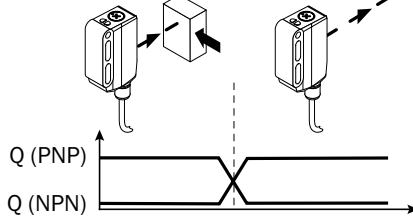

**2**

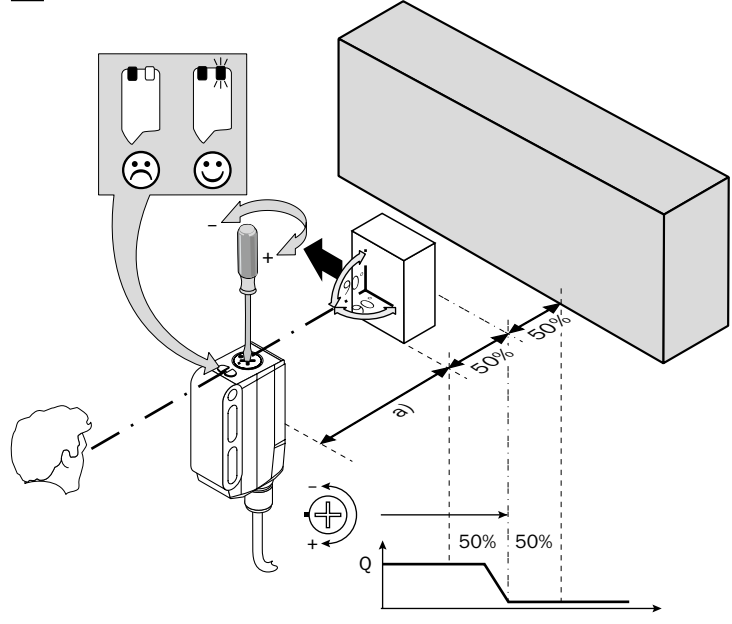

a) WTB9xxL-3xxx6x: 25 ... 300 mm/90 %  
WTB9xxL-3xxx9x: 25 ... 400 mm/90 %



DEUTSCH

**Reflexions-Lichttaster**  
mit sichtbarem Rotlicht (Laser)  
**Betriebsanleitung**

Bei Geräten der

Laserklasse 1:

<b>LASERKLASSE 1</b>	
	<b>Laser 1</b>
EN/IEC 60825-1:2014	
Maximale Pulsleistung: < 2,5 mW Impulsdauer: 4 µs Wellenlänge: 650 - 670 nm	
Entspricht 21 CFR 1040.10 und 1040.11 mit Ausnahme von Abweichungen nach Laser-Hinweis 56, 08. Mai 2019	

Bei Geräten der

Laserklasse 2:

<b>Laserstrahlung</b> <b>NICHT IN DEN STRAHL STARREN</b> <b>LASERPRODUKT DER KLASSE 2</b>	
	<b>Laser 2</b>
EN/IEC 60825-1:2014	
Maximale Pulsleistung: < 5,0 mW Impulsdauer: 4 µs Wellenlänge: 650 - 670 nm	
Entspricht 21 CFR 1040.10 und 1040.11 mit Ausnahme von Abweichungen nach Laser-Hinweis 56, 08. Mai 2019	

**Sicherheitshinweise**

- Kein Sicherheitsbauteil gemäß EU-Maschinenrichtlinie.
- Vor der Inbetriebnahme die Betriebsanleitung lesen.
- Anschluss, Montage und Einstellung nur durch Fachpersonal.
- Gerät bei Inbetriebnahme vor Feuchte und Verunreinigung schützen.
- UL: The device shall be supplied from an isolating transformer having a secondary overcurrent protective device that complies with UL 248 to be installed in the field rated either:
  - a) max 5 amps for voltages 0 ~ 20 V (0 ~ 28.3 V peak), or
  - b) 100 / Vp for voltages of 20 ~ 30 V (28.3 ~ 42.4 V peak).
 Alternatively, they can be supplied from a Class 2 power supply.
- UL Environmental Rating: Enclosure type 1.

**Bestimmungsgemäße Verwendung**

Der Reflexions-Lichttaster WTB9L-3 ist ein optoelektronischer Sensor und wird zum optischen, berührungslosen Erfassen von Objekten eingesetzt.

**Inbetriebnahme**

Montieren Sie den Sensor an einer geeigneten Halterung. Geeignete Haltewinkel finden Sie z. B. im Zubehör-Programm von SICK.

Bei Stecker-Versionen verbinden Sie den Sensor spannungsfrei mit einer Leitungsdose. Bei Versionen mit Anschlussleitung schließen Sie die Leitungen spannungsfrei an. Die PIN- / Leitungsbelegung entnehmen Sie Bild B (BN = braun, BU = blau, BK = schwarz, WH = weiß). Dann Betriebsspannung anlegen.

**Einstellung Tastweite:**

Maximale Tastweite und Remissionsvermögen des Tastgütes sowie des Hintergrundes beachten. Bewegungsrichtung des Objektes relativ zum Sensor einhalten. Drehknopf auf Max. stellen. Objekt positionieren. Lichtleck auf Objekt ausrichten. Die Lichtempfangsanzeige leuchtet.

Leuchtet die Lichtempfangsanzeige nicht oder blinkt sie, Lichttaster neu justieren, reinigen bzw. Einsatzbedingungen überprüfen.

Objekt entfernen, die Lichtempfangsanzeige muss erlöschen.

Leuchtet die Lichtempfangsanzeige weiterhin oder blinkt sie, ist der Hintergrundinfluss zu groß. Ist dies der Fall, Tastweite am Drehknopf so weit reduzieren, bis die Empfangsanzeige erlischt bzw. Einsatzbedingungen überprüfen.

PNP (Last → M): Objekt wird erkannt, Ausgang (Q) HIGH  
NPN (Last → L+): Objekt wird erkannt, Ausgang (Q) LOW  
Q jeweils invertiert

**Wartung**

SICK-Lichtschranken sind wartungsfrei.  
Wir empfehlen, in regelmäßigen Abständen – die optischen Grenzflächen zu reinigen, – Verschraubungen und Steckverbindungen zu überprüfen.

Veränderungen an Geräten dürfen nicht vorgenommen werden.

**WTB9xxL**

Laser class	Laserklasse	Laser de classe	Classe de laser
Sensing range TW <sup>1)</sup>	Tastweite TW <sup>1)</sup>	Distance de détection TW <sup>1)</sup>	Alcance de detecção TW <sup>1)</sup>
Light spot diameter/distance	Lichtfleckdurchmesser/Entfernung	Diamètre de la tache lumineuse/Distance	Diâmetro do ponto de luz/distância
Supply voltage Us	Versorgungsspannung Us	Tension d'alimentation Us	Tensão de força Us
Output current Imax	Ausgangsstrom Imax	Courant de sortie Imax	Corrente de saída Imax
Signal sequence min.	Signalfolge min.	Fréquence mini	Sequência mín. de sinais
Response time	Ansprechzeit	Temps de réponse	Tempo de reação
Enclosure rating	Schutzart	Type de protection	Tipo de proteção
Protection class	Schutzklasse	Classe de protection	Classe de proteção
Circuit protection	Schutzschaltungen	Circuits de protection	Circuitos protetores
Ambient operating temperature	Betriebsumgebungstemperatur	Température ambiante	Temperatura ambiente de operação
Extended ambient operating temperature	Erweiterte Betriebsumgebungstemperatur	Température ambiante de service étendue	Temperatura ambiente operacional ampliada
1) Object 90 % reflection according to DIN 5033	1) Objekt 90 % Remission nach DIN 5033	1) Objet Luminance de 90 % selon DIN 5033	1) Objeto: 90 % de remissão segundo DIN 5033
2) Limits, reverse polarity protected.	2) Grenzwerte, verpölsicher.	2) Valeurs limites, protégé contre l'inversion de polarité.	2) Valores limite, protegido contra polaridade reversa.
Operation in short-circuit protected network max. 8 A	Betrieb in kurzschlussgeschütztem Netz max. 8 A	Service dans un réseau protégé contre les courts-circuits 8 A au maximum	Operação em rede protegida contra curto-circuitos máx. 8 A
3) A = Us connections reverse polarity protected	3) A = Us-Anschlüsse verpölsicher	3) A = Raccordements Us protégés contre les inversions de polarité	3) A = Conexões Us protegidas contra inversão de polos
B = inputs/outputs reverse polarity protected	B = Ein- und Ausgänge verpölsicher	B = Entrées/Sorties protégées contre les inversions de polarité	B = Entradas/saídas protegidas contra inversão de polos
C = interference pulse suppression	C = Störimpulsunterdrückung	C = Suppression des impulsions parasites	C = Supressão de impulsos parasitas
As of Tu = 50 °C a supply voltage of Vmax = 24 V and ein max. output current of Imax = 50 mA is permissible.	Ab Tu = 50 °C ist eine Versorgungsspannung Vmax = 24 V und ein max. Ausgangsstrom Imax = 50 mA zulässig.	A partir d'une température de 50 °C, une tension d'alimentation de Vmax = 24 V et un courant de sortie max. Imax = 50 mA sont autorisés.	A partir de uma temperatura ambiente de 50 °C é permitida uma tensão de alimentação Vmax = 24 V e uma corrente máxima de saída Imax = 50 mA.
Operation below Tu = -10 °C is possible if the sensor is already switched on at Tu > -10 °C, then cools down and the supply voltage is subsequently not switched off. Switching on below Tu = -10 °C is not permissible.	Ein Betrieb unter Tu = -10 °C ist möglich, wenn der Sensor bereits bei Tu > -10 °C eingeschaltet wird, dann abkühlt und nicht mehr von der Versorgungsspannung getrennt wird. Ein Einschalten unter Tu = -10 °C ist nicht zulässig.	Un fonctionnement à une température inf. à -10 °C est possible si le capteur avait déjà été allumé à une temp. > -10 °C, s'il s'est ensuite refroidi et s'il n'a pas été entre temps débranché de la tension d'alimentation. Une mise en marche à une température inf. à -10 °C n'est pas autorisée.	Um funcionamento abaixo da temperatura ambiente de -10 °C é possível quando o sensor é ligado a uma temperatura ambiente > -10 °C, em seguida é arrefecido e não mais desconectado da tensão de alimentação. Não é permitido ligá-lo a uma temperatura abaixo de -10 °C.

**WTB9xxL**

Laser classe	Clase de láser	級激光产品	クラスレーザ製品
Distanza di ricezione TW <sup>1)</sup>	Rango de exploración TW <sup>1)</sup>	探测距离 TW <sup>1)</sup>	検出範囲 TW <sup>1)</sup>
Diametro punto luminoso/distanza	Diámetro/distancia de mancha de luz	光点直径 / 距離	スポット径 / 距離
Tensione di alimentazione Us	Tensión de alimentación Us	电源电压 Us	供給電圧 Us
Corrente di uscita max. Imax	Corriente de salida Imax	输出电流 Imax	最大出力電流 Imax
Sequenza segnali min.	Secuencia de señales min.	信号流 min	信号伝達時間 min.
Tempo di risposta	Tiempo de reacción	触发时间	応答時間
Tipo di protezione	Tipo de protección	保护种类	保護等級
Classe di protezione	Protección clase	保护级别	保護クラス
Commutazioni di protezione	Circuitos de protección	保护回路	保護回路
Temperatura ambiente circostante	Temperatura ambiente de servicio	工作环境-温度	動作周囲温度
Temperatura di funzionamento ambiente estesa	Temperatura ambiente de servicio ampliada	更大的运行环境温度范围	動作周囲温度の拡大

- 1) Oggetto 90 % remissione sec. DIN 5033
- 2) Valori limite, Con protezione dall'inversione di polarità., Funcionamiento en la red con protección dai cortocircuitos, máx. 8 A
- 3) A = Us-collegamenti con protez. contro inversione di poli B = entrate/uscite con protezione contro inversione di poli C = soppressione impulsi di disturbo
- 4) A partire da una temperatura di 50°C sono consentite una tensione di approvvigionamento Vmax = 24 V e una corrente in uscita massima Imax = 50 mA. È possibile un funzionamento sotto i -10 °C, se il sensore viene acceso a una temperatura > -10 °C, quindi viene raffreddato e non viene più staccato dalla tensione di approvvigionamento. Non è consentita l'accensione sotto i -10 °C
- 1) 90 % 漫反射比物体按照 DIN 5033
- 2) 极限值，反极性保护，Funcionamiento en la red protegida contra cortocircuito, 最大 8 A。
- 3) A = Us-接头防反接 B = 输入 / 输出防反接 C = 消除干扰脉冲
- 4) 超过 50 °C 时允许的最大电源电压 Vmax 为 24 V，最大输出电流 Imax 为 50 mA。可在低于 Y10 °C 时运行，前提是传感器已在高于 Y10 °C 时开启，然后降温且不断电。不得在低于 Y10 °C 时开启。
- 1) 対象物 90% の反射率 DIN 5033 に準拠
- 2) 限界値、逆極保護、短絡保護された回路での使用最大 8 A
- 3) A = Us 電源電圧逆接保護 B = 出力回路逆接保護 C = 干渉パルス抑制
- 4) Tu (周囲温度) = 50 °C 以上は、供給電圧 Vmax = 24 V および最大出力電流 Imax = 50 mA が許可されています。Tu = -10 °C 以下での動作は、センサがすでに Tu > -10 °C でオンにされた後冷却され、供給電源から切断されていない場合に可能となります。Tu = -10 °C 以下ですイッチをオンにすることは許可されていません。

FRANÇAIS					
<p><b>Détecteur réflex</b> avec lumière de rouge (Laser) <b>Instructions de service</b></p>					
<p>For laser class 1 devices:</p>					
<table> <tbody><tr> <th>LASER CLASS 1</th></tr> <tr> <td><span></span> <p>Laser 1</p></td></tr> <tr> <td>EN/IEC 60825-1:2014</td></tr> <tr> <td>Maximum pulse power &lt; 2,5 mW <p>Puls length: 4 µs</p> Wavelength: 650 - 670 nm</td></tr> <tr> <td>Complies with 21 CFR 1040.10 and 1040.11 except for deviations pursuant to Laser Notice No. 56, dated May 08, 2019</td></tr> </tbody></table>	LASER CLASS 1	<span></span> <p>Laser 1</p>	EN/IEC 60825-1:2014	Maximum pulse power < 2,5 mW <p>Puls length: 4 µs</p> Wavelength: 650 - 670 nm	Complies with 21 CFR 1040.10 and 1040.11 except for deviations pursuant to Laser Notice No. 56, dated May 08, 2019
LASER CLASS 1					
<span></span> <p>Laser 1</p>					
EN/IEC 60825-1:2014					
Maximum pulse power < 2,5 mW <p>Puls length: 4 µs</p> Wavelength: 650 - 670 nm					
Complies with 21 CFR 1040.10 and 1040.11 except for deviations pursuant to Laser Notice No. 56, dated May 08, 2019					
<p>For laser class 2 devices:</p>					
<table> <tbody><tr> <th>Laser Radiation DO NOT STARE INTO BEAM CLASS 2 LASER PRODUCT</th></tr> <tr> <td><span></span> <p>Laser 2</p></td></tr> <tr> <td>EN/IEC 60825-1:2014</td></tr> <tr> <td>Maximum pulse power &lt; 5,0 mW <p>Puls length: 4 µs</p> Wavelength: 650 - 670 nm</td></tr> <tr> <td>Complies with 21 CFR 1040.10 and 1040.11 except for deviations pursuant to Laser Notice No. 56, dated May 08, 2019</td></tr> </tbody></table>	Laser Radiation DO NOT STARE INTO BEAM CLASS 2 LASER PRODUCT	<span></span> <p>Laser 2</p>	EN/IEC 60825-1:2014	Maximum pulse power < 5,0 mW <p>Puls length: 4 µs</p> Wavelength: 650 - 670 nm	Complies with 21 CFR 1040.10 and 1040.11 except for deviations pursuant to Laser Notice No. 56, dated May 08, 2019
Laser Radiation DO NOT STARE INTO BEAM CLASS 2 LASER PRODUCT					
<span></span> <p>Laser 2</p>					
EN/IEC 60825-1:2014					
Maximum pulse power < 5,0 mW <p>Puls length: 4 µs</p> Wavelength: 650 - 670 nm					
Complies with 21 CFR 1040.10 and 1040.11 except for deviations pursuant to Laser Notice No. 56, dated May 08, 2019					

#### Remarques relatives à la sécurité

- Il ne s'agit pas d'un composant de sécurité conformément à la Directive CE sur les machines.
- Lire le manuel d'utilisation avant la mise en service.
- Faire effectuer le raccordement, le montage et le réglage uniquement par un personnel spécialisé.
- Protéger l'appareil de l'humidité et des impuretés lors de la mise en service.
- UL: The device shall be supplied from an isolating transformer having a secondary overcurrent protective device that complies with UL 248 to be installed in the field rated either:
  - a) max 5 amps for voltages 0 ~ 20 V (0 ~ 28.3 V peak), or
  - b) 100 / Vp for voltages of 20 ~ 30 V (28.3 ~ 42.4 V peak).
Alternatively, they can be supplied from a Class 2 power supply.
UL Environmental Rating: Enclosure type 1.

#### Utilisation conforme

La barrière lumineuse à réflexion WTB9L-3 est un capteur optoélectronique qui sert à la détection visuelle d'objets, d'animaux ou de personnes sans contact direct.Mise en service

- Monter le capteur sur un support approprié. Chercher des équerres adaptées, par exemple dans la gamme d'accessoires de SICK.

Sur les versions enfichables, brancher le capteur hors tension sur un boîtier de connecteurs. Sur les versions avec câble de raccordement, raccorder les câbles, appareil hors tension. Le branchement des câbles / broches est disponible dans le schéma **B** (BN = brun, BU = bleu, BK = noir, WH = blanc). Puis mettre l'appareil sous tension.

#### Réglage Distance de détection

Respecter la portée de détection maximale, les capacités de réflexion de l'objet et de l'arrière-plan. Maintenir le sens de déplacement de l'objet en relation avec le capteur. Placer la molette sur Max. Mettre l'objet en position. Orienter le spot lumineux sur l'objet. Le témoin de réception lumineuse s'allume.

Si le témoin d'affichage de réception lumineuse ne s'allume pas ou s'il clignote, le nettoyer ou contrôler les conditions d'utilisation.

Enlever l'objet. le témoin de réception doit s'éteindre.

Si le témoin de réception reste allumé ou s'il continue de clignoter, cela signifie que l'influence de l'arrière-plan est trop forte. Si tel était le cas, baisser la portée le plus possible avec la molette jusqu' à ce que le témoin s'éteigne ou contrôler les conditions d'utilisation.

- PNP (charge → M): L'objet est détecté, sortie (Q) HIGH
NPN (charge → L+): L'objet est détecté, entrée (Q) LOW
Q inversé à chaque positon

#### Maintenance

Les barrières lumineuses SICK sont sans entretien.

Nous vous recommandons de procéder régulièrement

- au nettoyage des surfaces optiques

- au contrôle des liaisons vissées et des connexions.

Ne procédez à aucune modification sur les appareils.

PORTUGUÊS					
<p><b>Foto-célula de reflexão no objeto</b> com luz vermelha visível (do campo espectral visível) (Laser) <b>Instruções de operação</b></p>					
<p>For laser class 1 devices:</p>					
<table> <tbody><tr> <th>LASER CLASS 1</th></tr> <tr> <td><span></span> <p>Laser 1</p></td></tr> <tr> <td>EN/IEC 60825-1:2014</td></tr> <tr> <td>Maximum pulse power &lt; 2,5 mW <p>Puls length: 4 µs</p> Wavelength: 650 - 670 nm</td></tr> <tr> <td>Complies with 21 CFR 1040.10 and 1040.11 except for deviations pursuant to Laser Notice No. 56, dated May 08, 2019</td></tr> </tbody></table>	LASER CLASS 1	<span></span> <p>Laser 1</p>	EN/IEC 60825-1:2014	Maximum pulse power < 2,5 mW <p>Puls length: 4 µs</p> Wavelength: 650 - 670 nm	Complies with 21 CFR 1040.10 and 1040.11 except for deviations pursuant to Laser Notice No. 56, dated May 08, 2019
LASER CLASS 1					
<span></span> <p>Laser 1</p>					
EN/IEC 60825-1:2014					
Maximum pulse power < 2,5 mW <p>Puls length: 4 µs</p> Wavelength: 650 - 670 nm					
Complies with 21 CFR 1040.10 and 1040.11 except for deviations pursuant to Laser Notice No. 56, dated May 08, 2019					
<p>For laser class 2 devices:</p>					
<table> <tbody><tr> <th>Laser Radiation DO NOT STARE INTO BEAM CLASS 2 LASER PRODUCT</th></tr> <tr> <td><span></span> <p>Laser 2</p></td></tr> <tr> <td>EN/IEC 60825-1:2014</td></tr> <tr> <td>Maximum pulse power &lt; 5,0 mW <p>Puls length: 4 µs</p> Wavelength: 650 - 670 nm</td></tr> <tr> <td>Complies with 21 CFR 1040.10 and 1040.11 except for deviations pursuant to Laser Notice No. 56, dated May 08, 2019</td></tr> </tbody></table>	Laser Radiation DO NOT STARE INTO BEAM CLASS 2 LASER PRODUCT	<span></span> <p>Laser 2</p>	EN/IEC 60825-1:2014	Maximum pulse power < 5,0 mW <p>Puls length: 4 µs</p> Wavelength: 650 - 670 nm	Complies with 21 CFR 1040.10 and 1040.11 except for deviations pursuant to Laser Notice No. 56, dated May 08, 2019
Laser Radiation DO NOT STARE INTO BEAM CLASS 2 LASER PRODUCT					
<span></span> <p>Laser 2</p>					
EN/IEC 60825-1:2014					
Maximum pulse power < 5,0 mW <p>Puls length: 4 µs</p> Wavelength: 650 - 670 nm					
Complies with 21 CFR 1040.10 and 1040.11 except for deviations pursuant to Laser Notice No. 56, dated May 08, 2019					

#### Notas de segurança

- Os componentes de segurança não se encontram em conformidade com a Diretiva Europeia de Máquinas.
- Ler as instruções de operação antes da colocação em funcionamento.
- A conexão, a montagem e o ajuste devem ser executados somente por pessoal técnico qualificado.
- Durante o funcionamento, manter o aparelho protegido contra impurezas e umidade.
- UL: The device shall be supplied from an isolating transformer having a secondary overcurrent protective device that complies with UL 248 to be installed in the field rated either:
  - a) max 5 amps for voltages 0 ~ 20 V (0 ~ 28.3 V peak), or
  - b) 100 / Vp for voltages of 20 ~ 30 V (28.3 ~ 42.4 V peak).
Alternatively, they can be supplied from a Class 2 power supply.
UL Environmental Rating: Enclosure type 1.

#### Especificações de uso

A barreira de luz com reflexão WTB9L-3 é um sensor optoeletrônico utilizado para a detecção óptica, sem contato, de objetos.

#### Colocação em funcionamento

- Instale o sensor em um suporte adequado. Ângulos de fixação adequados podem ser encontrados p.ex. no programa de acessórios da SICK.

Para versões com conector, conecte o sensor com uma caixa de linha sem estar ligado à tensão. Para versões com cabo de conexão conecte os cabos sem tensão. A configuração dos pinos / cabos pode ser encontrada na ilustração **B** (BN = marrom, BU = azul, BK = preto, WH = branco). Em seguida, aplicar a.

#### Ajuste do alcance de detecção:

Observar o alcance máximo de detecção e a refletividade do objeto a ser detectado, bem como o plano de fundo. Manter a direção do movimento do objeto em relação ao objeto. Ajustar o botão giratório no máx. Posicionar o objeto. Alinhar o ponto luminoso sobre o objeto. O indicador de recepção de luz acende.

Se o indicador de recepção de luz não acender ou se piscar, ajustar, limpar e/ou verificar as condições de operação do sensor luminoso.

Remover o objeto, o sinal de recepção de luz deve apagar.

Se o indicador de recepção de luz permanecer aceso ou piscar, significa que a interferência de fundo está muito forte. Se for esse o caso, reduzir o alcance de detecção com o botão giratório até o indicador de recepção apagar ou verifique as condições de operação.

- PNP (carga → M): objeto é detectado, saída (Q) HIGH
NPN (carga → L+): objeto é detectado, saída (Q) LOW
Q respectivamente invertido

#### Manutenção

As barreiras de luz SICK não requerem manutenção.

Recomendamos que se efetue em intervalos regulares

- uma limpeza das superfícies ópticas

- uma verificação das conexões rosçadas e dos conectores.

Não são permitidas modificações no aparelho.

ITALIANO					
<p><b>Sensore luminosa a riflessione</b> con luce rossa visibile (Laser) <b>Istruzioni per l'uso</b></p>					
<p>For laser class 1 devices:</p>					
<table> <tbody><tr> <th>LASER CLASS 1</th></tr> <tr> <td><span></span> <p>Laser 1</p></td></tr> <tr> <td>EN/IEC 60825-1:2014</td></tr> <tr> <td>Maximum pulse power &lt; 2,5 mW <p>Puls length: 4 µs</p> Wavelength: 650 - 670 nm</td></tr> <tr> <td>Complies with 21 CFR 1040.10 and 1040.11 except for deviations pursuant to Laser Notice No. 56, dated May 08, 2019</td></tr> </tbody></table>	LASER CLASS 1	<span></span> <p>Laser 1</p>	EN/IEC 60825-1:2014	Maximum pulse power < 2,5 mW <p>Puls length: 4 µs</p> Wavelength: 650 - 670 nm	Complies with 21 CFR 1040.10 and 1040.11 except for deviations pursuant to Laser Notice No. 56, dated May 08, 2019
LASER CLASS 1					
<span></span> <p>Laser 1</p>					
EN/IEC 60825-1:2014					
Maximum pulse power < 2,5 mW <p>Puls length: 4 µs</p> Wavelength: 650 - 670 nm					
Complies with 21 CFR 1040.10 and 1040.11 except for deviations pursuant to Laser Notice No. 56, dated May 08, 2019					
<p>For laser class 2 devices:</p>					
<table> <tbody><tr> <th>Laser Radiation DO NOT STARE INTO BEAM CLASS 2 LASER PRODUCT</th></tr> <tr> <td><span></span> <p>Laser 2</p></td></tr> <tr> <td>EN/IEC 60825-1:2014</td></tr> <tr> <td>Maximum pulse power &lt; 5,0 mW <p>Puls length: 4 µs</p> Wavelength: 650 - 670 nm</td></tr> <tr> <td>Complies with 21 CFR 1040.10 and 1040.11 except for deviations pursuant to Laser Notice No. 56, dated May 08, 2019</td></tr> </tbody></table>	Laser Radiation DO NOT STARE INTO BEAM CLASS 2 LASER PRODUCT	<span></span> <p>Laser 2</p>	EN/IEC 60825-1:2014	Maximum pulse power < 5,0 mW <p>Puls length: 4 µs</p> Wavelength: 650 - 670 nm	Complies with 21 CFR 1040.10 and 1040.11 except for deviations pursuant to Laser Notice No. 56, dated May 08, 2019
Laser Radiation DO NOT STARE INTO BEAM CLASS 2 LASER PRODUCT					
<span></span> <p>Laser 2</p>					
EN/IEC 60825-1:2014					
Maximum pulse power < 5,0 mW <p>Puls length: 4 µs</p> Wavelength: 650 - 670 nm					
Complies with 21 CFR 1040.10 and 1040.11 except for deviations pursuant to Laser Notice No. 56, dated May 08, 2019					

#### Avvertenze sulla sicurezza

- Nessun componente di sicurezza conformemente alla direttiva macchine UE.
- Prima della messa in funzione leggere le istruzioni d'uso.
- Allacciamento, montaggio e regolazione solo a cura di personale tecnico specializzato.
- Alla messa in funzione proteggere l'apparecchio dall'umidità e dalla sporcizia.
- UL: The device shall be supplied from an isolating transformer having a secondary overcurrent protective device that complies with UL 248 to be installed in the field rated either:
  - a) max 5 amps for voltages 0 ~ 20 V (0 ~ 28.3 V peak), or
  - b) 100 / Vp for voltages of 20 ~ 30 V (28.3 ~ 42.4 V peak).
Alternatively, they can be supplied from a Class 2 power supply.
UL Environmental Rating: Enclosure type 1.

#### Impiego conforme agli usi previsti

La fotocellula a riflessione WTB9L-3 è un sensore optoelettronico utilizzato per il rilevamento ottico senza contatto di oggetti.

#### Messa in funzione

- Montare il sensore a un supporto idoneo. Le informazioni relative agli angoli di inclinazione corretti sono reperibili ad es. nel catalogo accessori SICK.

Per le versioni a spina, collegare il sensore non ancora in tensione a una cassetta di conduzione. Per le versioni con cavo di collegamento, collegare i cavi non ancora in tensione. La disposizione dei contatti e dei cavi è reperibile nella figura **B** (BN = marrone, BU = blu, BK = nero, WH = bianco). Ora è possibile mettere in tensione l'apparecchio.

#### Impostazione della distanza di ricezione:

Rispettare la distanza massima di ricezione e la capacità di riflettenza dell'oggetto e dello sfondo. Rispettare la direzione dell'oggetto in relazione al sensore. Impostare la manopola su «max.». Posizionare l'oggetto. Orientare il punto luminoso in direzione dell'oggetto. L'indicatore di ricezione della luce è acceso.

Se l'indicatore di ricezione della luce non si accende o lampeggia, regolare di nuovo la fotocellula, pulirla e verificarne le condizioni di impiego.

Rimuovere l'oggetto, l'indicatore di ricezione deve spegnersi.

Se l'indicatore di ricezione resta acceso o lampeggia, l'influenza dello sfondo è eccessiva. In questi casi, ridurre la distanza di ricezione tramite la manopola fino a far spegnere l'indicatore di ricezione e verificare le condizioni di esercizio.

- PNP (carico → M): l'oggetto viene riconosciuto, uscita (Q) HIGH
NPN (carico → L+): l'oggetto viene riconosciuto, uscita (Q) LOW
Q rispettivamente invertito.

#### Manutenzione

Le barriere fotoelettriche SICK sono esenti da manutenzione.

Consigliamo di pulire in intervalli regolari

- le superfici limite ottiche

- verificare i collegamenti a vite e gli innesti a spina.

Non è consentito effettuare modifiche agli apparecchi.

ESPAÑOL					
<p><b>Palpador fotoeléctrico de reflexión</b> con luz roja visible (Láser) <b>Manual de Servicio</b></p>					
<p>For laser class 1 devices:</p>					
<table> <tbody><tr> <th>LASER CLASS 1</th></tr> <tr> <td><span></span> <p>Laser 1</p></td></tr> <tr> <td>EN/IEC 60825-1:2014</td></tr> <tr> <td>Maximum pulse power &lt; 2,5 mW <p>Puls length: 4 µs</p> Wavelength: 650 - 670 nm</td></tr> <tr> <td>Complies with 21 CFR 1040.10 and 1040.11 except for deviations pursuant to Laser Notice No. 56, dated May 08, 2019</td></tr> </tbody></table>	LASER CLASS 1	<span></span> <p>Laser 1</p>	EN/IEC 60825-1:2014	Maximum pulse power < 2,5 mW <p>Puls length: 4 µs</p> Wavelength: 650 - 670 nm	Complies with 21 CFR 1040.10 and 1040.11 except for deviations pursuant to Laser Notice No. 56, dated May 08, 2019
LASER CLASS 1					
<span></span> <p>Laser 1</p>					
EN/IEC 60825-1:2014					
Maximum pulse power < 2,5 mW <p>Puls length: 4 µs</p> Wavelength: 650 - 670 nm					
Complies with 21 CFR 1040.10 and 1040.11 except for deviations pursuant to Laser Notice No. 56, dated May 08, 2019					
<p>For laser class 2 devices:</p>					
<table> <tbody><tr> <th>Laser Radiation DO NOT STARE INTO BEAM CLASS 2 LASER PRODUCT</th></tr> <tr> <td><span></span> <p>Laser 2</p></td></tr> <tr> <td>EN/IEC 60825-1:2014</td></tr> <tr> <td>Maximum pulse power &lt; 5,0 mW <p>Puls length: 4 µs</p> Wavelength: 650 - 670 nm</td></tr> <tr> <td>Complies with 21 CFR 1040.10 and 1040.11 except for deviations pursuant to Laser Notice No. 56, dated May 08, 2019</td></tr> </tbody></table>	Laser Radiation DO NOT STARE INTO BEAM CLASS 2 LASER PRODUCT	<span></span> <p>Laser 2</p>	EN/IEC 60825-1:2014	Maximum pulse power < 5,0 mW <p>Puls length: 4 µs</p> Wavelength: 650 - 670 nm	Complies with 21 CFR 1040.10 and 1040.11 except for deviations pursuant to Laser Notice No. 56, dated May 08, 2019
Laser Radiation DO NOT STARE INTO BEAM CLASS 2 LASER PRODUCT					
<span></span> <p>Laser 2</p>					
EN/IEC 60825-1:2014					
Maximum pulse power < 5,0 mW <p>Puls length: 4 µs</p> Wavelength: 650 - 670 nm					
Complies with 21 CFR 1040.10 and 1040.11 except for deviations pursuant to Laser Notice No. 56, dated May 08, 2019					

#### Indicaciones de seguridad

- No se trata de un componente de seguridad según la Directiva de máquinas de la UE.
- Lea las instrucciones de servicio antes de efectuar la puesta en funcionamiento.
- La conexión, el montaje y el ajuste deben ser efectuados exclusivamente por técnicos especialistas.
- Proteja el equipo contra la humedad y la suciedad durante la puesta en funcionamiento.
- UL: The device shall be supplied from an isolating transformer having a secondary overcurrent protective device that complies with UL 248 to be installed in the field rated either:
  - a) max 5 amps for voltages 0 ~ 20 V (0 ~ 28.3 V peak), or
  - b) 100 / Vp for voltages of 20 ~ 30 V (28.3 ~ 42.4 V peak).
Alternatively, they can be supplied from a Class 2 power supply.
UL Environmental Rating: Enclosure type 1.

#### Uso conforme a lo previsto

El sensor luminoso de reflexión WTB9L-3 es un sensor optoelectrónico empleado para la detección óptica y sin contacto de objetos.

#### Puesta en funcionamiento

- Monte el sensor en un soporte adecuado. Hay disponibles ángulos de sujeción adecuados en el programa de accesorios de SICK.

En las versiones con conector, conecte el sensor a una toma de red sin tensión. En las versiones con cable de conexión, conecte los cables sin tensión. En la figura **B** puede consultar la asignación de los cables y las patillas (BN = marrón, BU = azul, BK = negro, WH = blanco). Establezca la tensión de funcionamiento.

#### Ajuste de la amplitud de exploración:

Observar la amplitud de exploración y capacidad de reflexión difusa del objeto explorado, así como el fondo. Respete la dirección de movimiento del objeto en relación al sensor. Ponga el botón giratorio en la posición Máx. Posicione el objeto. Oriente el punto luminoso hacia el objeto. Se ilumina el indicador de recepción.

Si el indicador de recepción no se ilumina o parpadea, vuelva a ajustar el palpador luminoso, límpielo o compruebe las condiciones de uso.

Retire el objeto: el indicador de recepción debe apagarse.

Si el indicador de recepción continúa iluminado o parpadea, significa que la influencia del fondo es excesiva. En ese caso, reduzca la amplitud de exploración con el botón giratorio hasta que el indicador de recepción se apague y compruebe las condiciones de uso.

- PNP (carga → M): trayectoria de la luz libre, salida (Q) HIGH
NPN (carga → L+): trayectoria de la luz libre, salida (Q) LOW
Q invertida respectivamente.

#### Mantenimiento

Las barreras fotoeléctricas SICK no precisan mantenimiento.

En intervalos regulares, recomendamos

- limpiar las superficies ópticas externas

- comprobar las uniones rosçadas y las conexiones.

No se permite realizar modificaciones en los aparatos.

中文					
<p><b>镜面反射型光电传感器</b> 直光束光电开关 (带激光) <b>操作程</b></p>					
<p>For laser class 1 devices:</p>					
<table> <tbody><tr> <th>LASER CLASS 1</th></tr> <tr> <td><span></span> <p>Laser 1</p></td></tr> <tr> <td>EN/IEC 60825-1:2014</td></tr> <tr> <td>Maximum pulse power &lt; 2,5 mW <p>Puls length: 4 µs</p> Wavelength: 650 - 670 nm</td></tr> <tr> <td>Complies with 21 CFR 1040.10 and 1040.11 except for deviations pursuant to Laser Notice No. 56, dated May 08, 2019</td></tr> </tbody></table>	LASER CLASS 1	<span></span> <p>Laser 1</p>	EN/IEC 60825-1:2014	Maximum pulse power < 2,5 mW <p>Puls length: 4 µs</p> Wavelength: 650 - 670 nm	Complies with 21 CFR 1040.10 and 1040.11 except for deviations pursuant to Laser Notice No. 56, dated May 08, 2019
LASER CLASS 1					
<span></span> <p>Laser 1</p>					
EN/IEC 60825-1:2014					
Maximum pulse power < 2,5 mW <p>Puls length: 4 µs</p> Wavelength: 650 - 670 nm					
Complies with 21 CFR 1040.10 and 1040.11 except for deviations pursuant to Laser Notice No. 56, dated May 08, 2019					
<p>For laser class 2 devices:</p>					
<table> <tbody><tr> <th>Laser Radiation DO NOT STARE INTO BEAM CLASS 2 LASER PRODUCT</th></tr> <tr> <td><span></span> <p>Laser 2</p></td></tr> <tr> <td>EN/IEC 60825-1:2014</td></tr> <tr> <td>Maximum pulse power &lt; 5,0 mW <p>Puls length: 4 µs</p> Wavelength: 650 - 670 nm</td></tr> <tr> <td>Complies with 21 CFR 1040.10 and 1040.11 except for deviations pursuant to Laser Notice No. 56, dated May 08, 2019</td></tr> </tbody></table>	Laser Radiation DO NOT STARE INTO BEAM CLASS 2 LASER PRODUCT	<span></span> <p>Laser 2</p>	EN/IEC 60825-1:2014	Maximum pulse power < 5,0 mW <p>Puls length: 4 µs</p> Wavelength: 650 - 670 nm	Complies with 21 CFR 1040.10 and 1040.11 except for deviations pursuant to Laser Notice No. 56, dated May 08, 2019
Laser Radiation DO NOT STARE INTO BEAM CLASS 2 LASER PRODUCT					
<span></span> <p>Laser 2</p>					
EN/IEC 60825-1:2014					
Maximum pulse power < 5,0 mW <p>Puls length: 4 µs</p> Wavelength: 650 - 670 nm					
Complies with 21 CFR 1040.10 and 1040.11 except for deviations pursuant to Laser Notice No. 56, dated May 08, 2019					

#### 安全须知

- 本设备非欧盟机械指令中定义的安全部件。
- 调试前请阅读操作程。
- 仅允许由专业人员进行接线、安装和设置。
- 调试时应防止设备受潮或脏污。
- UL: The device shall be supplied from an isolating transformer having a secondary overcurrent protective device that complies with UL 248 to be installed in the field rated either:
  - a) max 5 amps for voltages 0 ~ 20 V (0 ~ 28.3 V peak), or
  - b) 100 / Vp for voltages of 20 ~ 30 V (28.3 ~ 42.4 V peak).
Alternatively, they can be supplied from a Class 2 power supply.
UL Environmental Rating: Enclosure type 1.

#### 正确使用须知

反射光传感器 WTB9L-3 是一种光电传感器，用于对物体进行非接触式的光学探测。

#### 调试

- 将传感器安装在一个合适的支架上。合适的固定角板请参见 SICK 配件产品系列。

如果是插接版本，则将传感器与导线插孔连接（确保无应力）。如果是带连接导线的版本，则连接导线（确保无应力）。布置 PIN/布线时请参考图 **B**（BN = 棕色、BU = 蓝色、BK = 黑色、WH = 白色）。然后接通工作电压。

#### 扫描范围设置：

注意最大扫描范围以及扫描对象和背景的反射能力。以传感器为参照物，保持目标物体的运动方向。将旋钮调至最大。定位物体。将光点对准物体。光接收指示灯亮起。

如果光接收指示灯未亮起或闪烁，则重新校准光学传感器，并进行清洁，或者检查使用条件。

移除物体，则光接收指示灯熄灭。

如果光接收指示灯继续亮起或者闪烁，则说明背景干扰过大。如果出现此类情况，则需不断减小旋钮上的扫描范围，直到接收指示器熄灭，或者检查使用条件。

- PNP（负载 → M）：识别到物体，输出端 (Q) HIGH
NPN（负载 → L+）：识别到物体，输出端 (Q) LOW
Q 始终可逆

#### 保养

SICK 光电开关无需保养。我们建议，定期

- 清洁镜头检测面

- 检查螺丝接头和插头连接。

不得对设备进行任何改装。

日本語					
<p><b>反射形光電スイッチ</b> 赤色光源タイプ (レーザー光使用) <b>取扱説明書</b></p>					
<p>For laser class 1 devices:</p>					
<table> <tbody><tr> <th>LASER CLASS 1</th></tr> <tr> <td><span></span> <p>Laser 1</p></td></tr> <tr> <td>EN/IEC 60825-1:2014</td></tr> <tr> <td>Maximum pulse power &lt; 2,5 mW <p>Puls length: 4 µs</p> Wavelength: 650 - 670 nm</td></tr> <tr> <td>Complies with 21 CFR 1040.10 and 1040.11 except for deviations pursuant to Laser Notice No. 56, dated May 08, 2019</td></tr> </tbody></table>	LASER CLASS 1	<span></span> <p>Laser 1</p>	EN/IEC 60825-1:2014	Maximum pulse power < 2,5 mW <p>Puls length: 4 µs</p> Wavelength: 650 - 670 nm	Complies with 21 CFR 1040.10 and 1040.11 except for deviations pursuant to Laser Notice No. 56, dated May 08, 2019
LASER CLASS 1					
<span></span> <p>Laser 1</p>					
EN/IEC 60825-1:2014					
Maximum pulse power < 2,5 mW <p>Puls length: 4 µs</p> Wavelength: 650 - 670 nm					
Complies with 21 CFR 1040.10 and 1040.11 except for deviations pursuant to Laser Notice No. 56, dated May 08, 2019					
<p>For laser class 2 devices:</p>					
<table> <tbody><tr> <th>Laser Radiation DO NOT STARE INTO BEAM CLASS 2 LASER PRODUCT</th></tr> <tr> <td><span></span> <p>Laser 2</p></td></tr> <tr> <td>EN/IEC 60825-1:2014</td></tr> <tr> <td>Maximum pulse power &lt; 5,0 mW <p>Puls length: 4 µs</p> Wavelength: 650 - 670 nm</td></tr> <tr> <td>Complies with 21 CFR 1040.10 and 1040.11 except for deviations pursuant to Laser Notice No. 56, dated May 08, 2019</td></tr> </tbody></table>	Laser Radiation DO NOT STARE INTO BEAM CLASS 2 LASER PRODUCT	<span></span> <p>Laser 2</p>	EN/IEC 60825-1:2014	Maximum pulse power < 5,0 mW <p>Puls length: 4 µs</p> Wavelength: 650 - 670 nm	Complies with 21 CFR 1040.10 and 1040.11 except for deviations pursuant to Laser Notice No. 56, dated May 08, 2019
Laser Radiation DO NOT STARE INTO BEAM CLASS 2 LASER PRODUCT					
<span></span> <p>Laser 2</p>					
EN/IEC 60825-1:2014					
Maximum pulse power < 5,0 mW <p>Puls length: 4 µs</p> Wavelength: 650 - 670 nm					
Complies with 21 CFR 1040.10 and 1040.11 except for deviations pursuant to Laser Notice No. 56, dated May 08, 2019					

#### 安全上の注意事項

- 本製品は EU 機械指令の要件を満たす安全コンポーネントではありません。
- 使用を開始する前に取扱説明書をお読みください。
- 接続、取付けおよび設定できるのは専門技術者に限ります。
- 装置を使用開始する際には、濡れたり汚れたりしないように保護してください。
- UL: The device shall be supplied from an isolating transformer having a secondary overcurrent protective device that complies with UL 248 to be installed in the field rated either:
  - a) max 5 amps for voltages 0 ~ 20 V (0 ~ 28.3 V peak), or
  - b) 100 / Vp for voltages of 20 ~ 30 V (28.3 ~ 42.4 V peak).
Alternatively, they can be supplied from a Class 2 power supply.
UL Environmental Rating: Enclosure type 1.

#### 使用目的

反射形光電スイッチ WTB9L-3 は光電センサで、対象物を光学技術により非接触で検知するための装置です。

#### 使用開始

- 適切なホルダーにセンサを取り付けてください。適切なギユメは、SICK の付属品プログラムで見つけることができます。

コネクター式の場合、センサに張力ががからないようにケーブルプラグに接続します。接続ケーブルの場合は、ケーブルに張力ががからないように接続します。PIN 割り当て / 配線割り当ては、図 **B** を参照してください (BN = 茶、BU = 青、BK = 黒、WH = 白)。続いて動作電圧を供給します。

#### 検出範囲の設定：

最大検出距離や対象物および背景の反射率に注意します。対象物の移動方向がセンサに対し、相対的になるように維持します。ロータリースイッチを最大に設定します。対象物を所定の位置に置きます。対象物に光点を合わせます。受光表示灯が点灯します。

受光表示灯が点灯しないまたは点滅する場合は、光センサを改めて調節し、汚れを取り除くか、あるいは使用条件を確認してください。

対象物を取り除くと、受光表示灯が消灯するはず です。

受光表示灯が引き続き点灯するかまたは点滅する場合、背景の影響力が強すぎます。この場合、信号強度表示が消灯するまでロータリースイッチの検出範囲を縮小するか、または使用条件を点検してください。

- PNP (負荷 → M)：対象物は検出されます。出力 (Q) HIGH
NPN (負荷 → L+)：対象物は検出されます。出力 (Q) LOW
Q それぞれ転置

#### メンテナンス

SICK の光電スイッチはメンテナンス不要です。

推奨する定期的な保守作業

- レンズ境界面の清掃

- ネジ締結と差込み締結の点検

デバイスに変更を加えることは一切禁止されています。