

SUPPLEMENTARY OPERATING INSTRUCTIONS

Enclosure GMS820P



Description
Installation
Technical Data



Document Information

Described Product

Product name: GMS820P
Basic device: GMS800 series gas analyzers

Document ID

Title: Supplementary Operating Instructions
Enclosure GMS820P
Part No.: 8015934
Version: 1.0
Release: 2012-07

Manufacturer

SICK AG
Erwin-Sick-Str. 1 · 79183 Waldkirch · Germany
Phone: +49 7641 469-0
Fax: +49 7641 469-1149
E-mail: info.pa@sick.de

Trademarks

Swagelok is a trademark of the Swagelok Company.
Other product names used in this document may also be trademarks and are only used for identification purposes.

Original Documents

The English edition 8015934 of this document is an original document of SICK AG.
SICK AG assumes no liability for the correctness of an unauthorized translation.
Please contact the manufacturer or your local representative in case of doubt.

Legal information

Subject to change without notice.

© SICK AG. All rights reserved.

Glossary

AC: Alternating Current

CS₂: Carbon disulfide.

DC: Direct Current

IP + 2-digit code: International Protection (also: Ingress Protection); degree of protection of a device according to IEC/DIN EN 60529. The first digit designates protection against contact and impurities, the second against moisture.

Warning Symbols



Hazard (general)



Hazard in potentially explosive atmospheres



Hazard by explosive substances/mixtures



Hazard by toxic substances

Warning Levels / Signal Words

WARNING

Risk or hazardous situation which *could* result in severe personal injury or death.

CAUTION

Hazard or unsafe practice which *could* result in personal injury or property damage.

NOTICE

Hazard which *could* result in property damage.

Information Symbols



Information on product characteristics with regard to protection against explosions (general)



Important technical information for this product



Important information on electric or electronic functions



Nice to know



Supplementary information



Link to information at another place

1	Important Information	5
1.1	Main hazards	6
1.2	Important operating information	6
1.3	Safety during installation and repairs	6
1.4	Application limitations	7
1.5	Additional documentation/information	7
2	Product Description	9
2.1	Product description	10
3	Mechanical Installation	11
3.1	Safety information	12
3.1.1	Safety during transport and assembly	12
3.1.2	Protection against dangerous sample gases	12
3.2	Assembly	13
3.2.1	Ensuring ambient conditions	13
3.2.2	Securing the enclosure	13
3.3	Gas connections	14
3.3.1	Feeding sample gas	15
3.3.2	Feeding purge gas connections for an Analyzer module (option)	15
3.3.3	Feeding purge gas to the upper enclosure section (option)	15
3.3.4	Ensuring enclosure venting (option)	15
4	Electrical Installation	17
4.1	Cable installation (general information)	18
4.1.1	Accessing the connection terminals	18
4.1.2	Suitable cables	18
4.1.3	Using cable inlets	18
4.1.4	Fastening cables	18
4.2	Main electrical connection	19
4.3	Signal connections (I/O)	20
4.3.1	Installing signal cables	20
4.3.2	Connecting signal cables	20
4.4	Intrinsically safe signal connections (option)	21
4.4.1	Technical layout of the intrinsically safe signal connections	21
4.4.2	Special technical data for intrinsically safe signal connections	21
4.4.3	Installation information for intrinsically safe signal connections	21
4.4.4	Electronic limit values for intrinsically safe signal connections	22
4.5	Closing the enclosure	22
5	Operation	23
5.1	Start-up procedure	24
5.2	Operating	24
5.3	Shutting down	24

6	Maintenance	25
6.1	Leak tightness checks	26
6.1.1	Leak tightness check of sample gas lines	26
6.1.2	Leak tightness check of purge gas paths	26
6.2	Checking/replacing flame blocks	26
6.3	Outer cleaning	26
7	Technical Data	27
7.1	Dimensions	28
7.2	Approvals	28
7.3	Enclosure specifications	28
7.4	Ambient conditions	29
7.5	Gas connections	29
7.6	Mains connection	30
7.7	Electrical safety	30

GMS820P

1 Important Information

Product description
Main information
Application limitations
Additional information

1.1 Main hazards

Health risks through dangerous sample gases

- ▶ → “GMS800” Series Operating Instructions

When shutting down



WARNING: Risk of explosions

In potentially explosive atmospheres:

- ▶ Do not open enclosure GMS820P as long as it is connected to mains voltage.
- ▶ *After disconnecting the GMS820P from mains voltage:* Wait at least 60 minutes before opening the upper enclosure section.
- ▶ Observe the safety information on the enclosure.

1.2 Important operating information

Before start-up

- ▶ Close the enclosure tight.
- ▶ *If the enclosure is damaged:* Do not put the GMS800 in enclosure GMS820P into operation and secure against unauthorized start-up.



The upper enclosure section has a mains switch for service purposes.

Operation

- ▶ Use the buttons on the lower enclosure section for operation. Do not open the enclosure during operation.
- ▶ *Before shutting down:* Purge the sample gas path with a dry neutral gas to prevent condensation in the measuring system.
- ▶ *After an event that could have activated or soiled the integrated flame blocks:* Have the flame blocks checked (→ page 26, §6.2).

In hazardous situations

- ▶ Switch-off the emergency switch or main switch of the host system.
- ▶ *If liquid has penetrated the enclosure:* Shut the device down immediately and interrupt the mains voltage at external source.

1.3 Safety during installation and repairs

- ▶ Only use enclosure GMS820P in potentially explosive atmospheres when allowed according to the specified zone, explosion group and temperature class (see type plate).
- ▶ Observe and follow the “special requirements” of the approval (→ page 7, § 1.4).
- ▶ Only allow skilled persons having knowledge of the relevant rules and regulations for potentially explosive atmospheres to carry out installation, start-up, maintenance and test – e.g.:
 - Range specification
 - Ignition protection types
 - Installation regulations, e.g. “Regulation concerning electrical equipment in hazardous areas (ExeV)”
- ▶ Do not modify enclosure GMS820P. Only have repairs carried out by the manufacturer or trained skilled persons.

1.4

Application limitations

Special conditions according to the approval document:

- The enclosure must be labeled with warning notices according to EN 60079-0 Sections 29.11 a) and d). [1]
- Use in areas with potentially explosive carbon disulfide atmosphere (LEL 0.6 percent per volume) is not allowed. [2]
- The allowable ambient temperature range is +5 °C to +45 °C.

[1] Carried out at manufacturer's factory.

[2] Lower explosion limit = 0.6 percent by volume CS₂ in air.

1.5

Additional documentation/information

This document supplements the Operating Instructions for GMS800 gas analyzers. It extends the "GMS800" Operating Instructions with technical information on the GMS820P.

- ▶ Observe the Operating Instructions delivered with the "GMS800".



The "GMS800" Operating Instructions also specify all further documents belonging to the individual device.



NOTICE:

- ▶ Pay primary attention to any individual information provided.

Other documents delivered

Operating Instructions of the Zener barriers [1]

- ▶ Observe when installing intrinsically safe signal connections.

[1] Only for versions with intrinsically safe signal connections (→ page 21, § 4.4)

GMS820P

2 Product Description

Characteristics
Product versions

2.1 Product description

Basic characteristics

- Enclosure GMS820P is designed for indoor wall fitting.
- Enclosure GMS820P comprises two sections (→ Fig. 1):

Section	Contains
Upper section: Analyzer enclosure	<ul style="list-style-type: none"> ● Physical components ● Electronic components ● Gas connections
Lower section: Connection enclosure	<ul style="list-style-type: none"> ● Mains connection ● Signal connections

- Enclosure sections are separated gas-tight.
- Gas connections have integrated flame blocks.

Fig. 1 Enclosure GMS820P

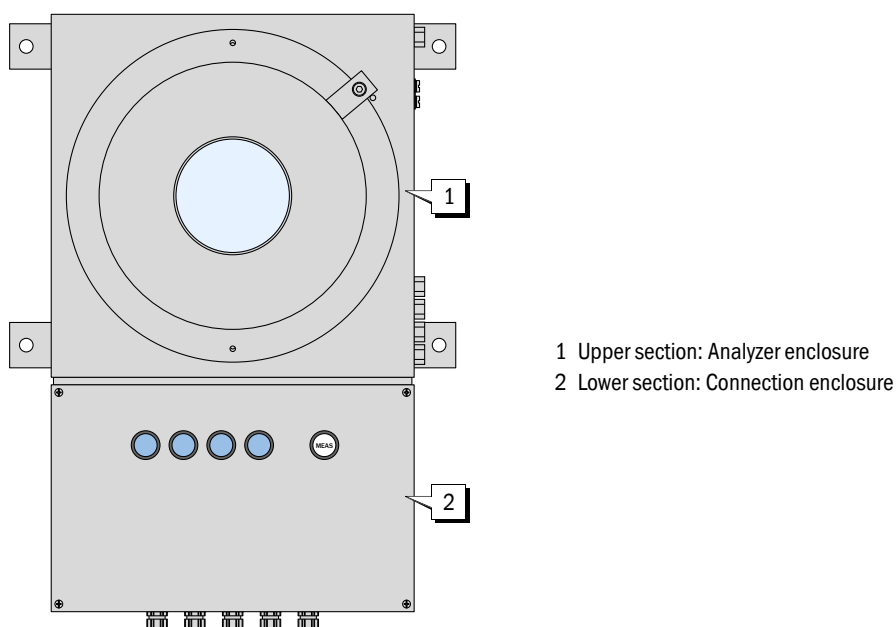

Suitability

Enclosure GMS820P may only be used in potentially explosive atmospheres in the zone, explosion group and temperature class specified on the type plate. The type plate is located on the right enclosure side.

Options

- Purge gas connections for the upper enclosure section (analyzer enclosure)
- Purge gas connections for an Analyzer module
- Gas connection for venting the upper enclosure section
- Intrinsically safe signal connections

GMS820P

3 Mechanical Installation

Safety information

Assembly

Gas connections

3.1 Safety information

3.1.1 Safety during transport and assembly

Lifting points



NOTICE: Damage through incorrect lifting

- ▶ Use the lifting points of the support rails on the rear side of the enclosure.
- ▶ Do not load the lower enclosure section.
- ▶ Do not use gas connections and cable inlets as lifting points.

Risk of injury



CAUTION: Risk of injury

The enclosure is heavy (weight → page 28, § 7.3). There is a risk of injury due to the enclosure weight and the hard, projecting enclosure parts should the enclosure drop down or make an uncontrolled movement.

During transport and assembly:

- ▶ Consider the enclosure weight before lifting.
- ▶ Wear safety shoes. Wear non-slip gloves.
- ▶ Handle the device carefully and safely. Secure during transport. Avoid falls and collisions.
- ▶ Call in further personnel as assistants as required.

3.1.2 Protection against dangerous sample gases

If the sample gas can be dangerous to health, combustible and/or corrosive:

- ▶ Make sure no dangerous situations can arise should a gas leak occur.
 - ▶ Check
 - whether a gas detector must be installed at the installation location
 - whether the enclosure must be purged continuously with a neutral gas during operation (with monitoring the discharged purge gas as required).
- Install appropriate additional devices as necessary.
- ▶ Check gas paths regularly for leak tightness (→ page 26, § 6.1).



WARNING: Health risk

If the sample gas can be dangerous to health and it is not sure whether internal gas paths are leak tight:

- ▶ *Before opening the upper enclosure section:* Take protective measures against escaping gas (e.g. breathing protection, suctioning off).

3.2 Assembly



- Dimensions → page 28, § 7.1
- Weight → page 28, § 7.3

3.2.1 Ensuring ambient conditions

Vibrations

- ▶ Protect the device against heavy jolts and vibrations (limit values → page 29, § 7.4).

Temperature

- ▶ Avoid enclosure exposure to direct sunlight.
- ▶ Maintain the allowable ambient temperature during operation (→ page 29, § 7.4).

Humidity

- ▶ Choose a dry installation location free from frost.
- ▶ Prevent moisture condensation – inside the device as well.
- ▶ Maintain the allowable relative air humidity (→ page 29, § 7.4).

Corrosive atmosphere

If the atmosphere at the installation location can be corrosive:

- ▶ Install enclosure GMS820P in an outer housing (e.g. closed cabinet). Purge the outer housing with a protective gas.

Atmospheres containing CS₂



WARNING: Application prohibited in atmospheres containing CS₂

- ▶ *If the CS₂ concentration in the ambient air at the planned installation location reaches or could exceed the lower explosion limit (LEL)^[1]: Do not use enclosure GMS820P.^[2]*

[1] LEL for CS₂= 0.6 percent by volume.

[2] Approval condition (→ page 7, § 1.4).

3.2.2 Securing the enclosure

- ▶ Secure the enclosure on a structure that can safely carry the weight of the enclosure.
- ▶ Fit the enclosure so that the enclosure underside is more or less horizontal (allowable offset → page 29, § 7.4).

3.3 Gas connections

Fig. 2 Right enclosure side

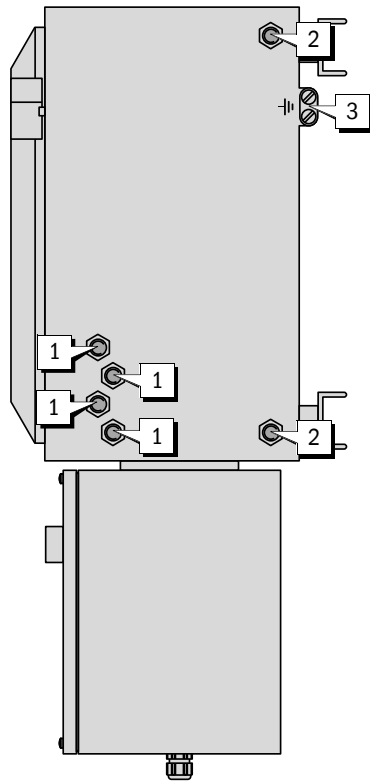

- 1 Sample gas connection
or
Option: Purge gas connection for an Analyzer module
- 2 Option: Purge gas connection for the upper enclosure section
or
Option: Gas connection for venting the enclosure
- 3 Bonding load connection



- Function of individual gas connections → Labeled on enclosure
- Technical details for gas connections → page 29, § 7.5
- Bonding load connection → page 19, § 4.2



WARNING: Risk of explosions

- ▶ Close off unused gas connections gas-tight.
Otherwise operation in potentially explosive atmospheres is not allowed.



Gas connections have integrated flame blocks.

- ▶ *After an event that could have activated or soiled the integrated flame blocks:* Have the flame blocks checked (→ page 26, § 6.2).

3.3.1 **Feeding sample gas**

- ▶ Observe the basic information and safety information concerning feeding sample gas:
 - Sample gas connections function → “GMS800 Series” Operating Instructions
 - Sample gas feed specifications → Supplementary Operating Instructions of the Analyzer Module fitted
- ▶ The approval requirements have priority (→ page 29, § 7.5).

3.3.2 **Feeding purge gas connections for an Analyzer module (option)**

Only valid for versions with appropriate purge gas connections (→ page 14, Fig. 2/)

- ▶ Feed the required purge gas via the “purge in analyzer” gas connection and channel the purge gas off via the “purge out analyzer” gas connection as described in the Supplementary Operating Instructions of the Analyzer module.
- ▶ Use nitrogen (techn.) as inert gas.
- ▶ Maintain the allowable purge gas pressure (→ page 29, § 7.5).

3.3.3 **Feeding purge gas to the upper enclosure section (option)**

Only valid for versions with appropriate purge gas connections (→ page 14, Fig. 2)

- ▶ Feed the purge gas via the “purge in enclosure” and channel off via the “purge out enclosure” gas connection.

3.3.4 **Ensuring enclosure venting (option)**

Only valid for versions with the “venting” gas connection

- ▶ *If the sample gas is not dangerous:* Leave the “venting” gas connection open.
- ▶ *If the sample gas can be dangerous:* Connect a gas line to the “venting” gas connection that runs to a location where escaping sample gas cannot cause any danger. The gas outlet must be open (without counter-pressure).



WARNING: Risk of explosions

- ▶ Do not close off the “venting” gas connection. Otherwise operating safety in potentially explosive atmospheres is not ensured.



Enclosure venting prevents higher gas pressure in the upper enclosure section should gas escape due to an internal gas leak.

GMS820P

4 Electrical Installation

Cable installation
Mains connection
Signal connections



- ▶ Let skilled persons with the necessary technical knowledge carry out the installation (refer also to → page 6, § 1.3).
- ▶ Observe and maintain approval regulations and specifications.

4.1 Cable installation (general information)

4.1.1 Accessing the connection terminals



- The electrical connections are in the lower enclosure section (→ page 19, Fig. 3).
- The upper enclosure section does not have to be opened.

1 Ensure a safe state:



WARNING: Risk of explosions

Before opening the lower enclosure section:

- ▶ Disconnect enclosure GMS820P from the mains voltage.
- ▶ Disconnect enclosure GMS820P from all other external voltages (e.g. signal lines). *Exception:* Connections to intrinsically safe power circuits can remain connected.

2 Open the lower enclosure section:

- Loosen front screws.
- Remove cover.

4.1.2 Suitable cables

- ▶ Only use cables with outer diameter 6 ... 13 mm (= suitable diameter for the cable inlets).
- ▶ Only use cables approved for use in the respective potentially explosive atmosphere.

4.1.3 Using cable inlets

- ▶ Close off cable inlets "flame-tight" (gas-tight) after installation.
- ▶ Close off unused cable inlets with sealing plugs or replace completely with closure caps. The sealing plugs and closure caps must be approved for use in potentially explosive atmospheres.
 - *Sealing plugs:* Select to match the allowable cable diameter and fit instead of a cable.
 - *Closure caps:* Select closure caps with M20x1.5 threads. Apply »Loctite 243« adhesive to threads and sealing surfaces.



The cable inlets are part of the approval.

Ä Do not replace cable inlets with a different type of cable inlet.



Keep removed sealing plugs.

4.1.4 Fastening cables

- ▶ Fit connected cables fixed, i.e. fasten cables along the whole length.

4.2 Main electrical connection

Potential equalization (PE, earth)

- ▶ Connect the earth connection on the upper enclosure section (→ page 14, Fig. 2) directly to the main potential (earth).

Mains connection

+i Suitable mains voltage/mains frequency → page 30, § 7.6

- ▶ Suitable cable diameter → page 18, § 4.1.2. Use mains cable with protective conductor.
- ▶ Lead the mains cable through one of the cable inlets in the lower enclosure section and connect to terminal strip X1 (→ Table 1).

Table 1 Mains connection terminals

Terminal	Function
X1.1	L1 Mains voltage - phase
X1.2	N Mains voltage - zero conductor
PE	Protective conductor

Fig. 3 Lower enclosure section (connection enclosure)

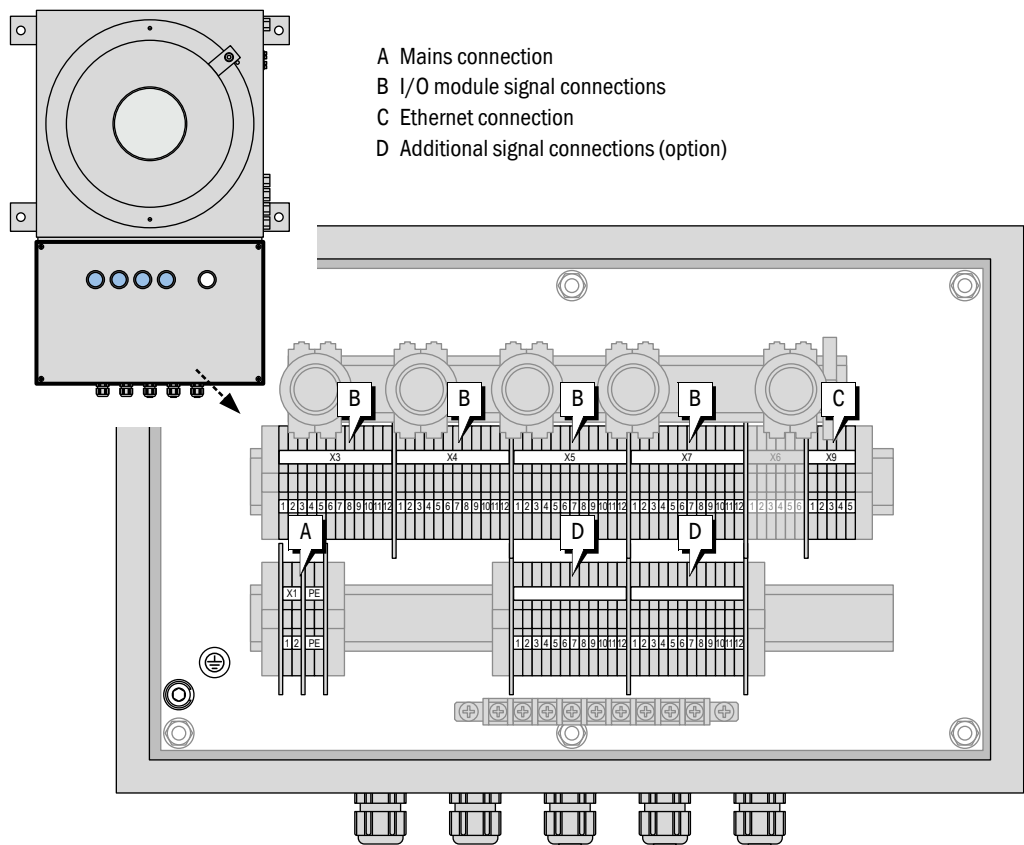

- Electronic fuses are in the upper enclosure section.
- The upper enclosure section has a mains switch for service purposes.

4.3 Signal connections (I/O)

4.3.1 Installing signal cables

- ▶ Lead the signal cable through a cable inlet in the lower enclosure section (→ page 19, Fig. 3).
- ▶ Lead connected signal cables out of the potentially explosive atmosphere and connect outside the potentially explosive atmosphere.

4.3.2 Connecting signal cables



NOTICE:

Electrostatic discharges can severely damage electronic components.

- ▶ *Before touching electrical connections and internal components:* Earth your body and tools used to discharge electrostatic charges.

Recommended method:

- ▶ *If the protective conductor is connected:* Touch a blank metal part of the enclosure.
- ▶ *Otherwise:* Touch a different blank metal surface that is connected to the protective conductor or has safe contact to the earthing.



- ▶ Pay primary attention to the individual information delivered.

Table 2

Signal connection terminals (standard)

Terminal	Function	
X3.x	I/O module signal connections ^[1]	
X4.x		
X5.x		
X7.x		
X6.x	<i>Used for internal wiring</i>	
X9.1	TX+	Ethernet connection
X9.2	TX-	
X9.3	RX+	
X9.4	RX-	
X9.5	Shield	
X9.6	<i>Not used (no connection)</i>	

[1] Terminal assignment and function description → "I/O Module" Supplementary Operating Instructions

- ▶ Connect signal lines to the desired terminals in the lower enclosure section.
- ▶ *On versions with additional signal connections (option):* Observe individual information delivered.
- ▶ *On versions with intrinsically safe signal connections (option):* Observe information in §4.4 (→ page 21).

4.4 Intrinsically safe signal connections (option)

Only valid for versions with intrinsically safe signal connections

4.4.1 Technical layout of the intrinsically safe signal connections

When desired, some of the analog outputs, digital inputs and digital outputs can be realized as intrinsically safe signal connections. In this case, additional modules (Zener barriers) are fitted in the upper enclosure section. All intrinsically safe connections can be configured according to customer requirements.

- Terminal assignment → individual information delivered
- Technical information on intrinsically safe signal connections → Operating Instructions of the Zener barriers

4.4.2 Special technical data for intrinsically safe signal connections

Signal connection	Parameter	Specification
Analog outputs ^[1]	Maximum voltage on connection terminals:	13 V
	Allowable load:	0 ... 200 Ω
Digital inputs	Maximum voltage on connection terminals:	26.5 V
Digital outputs	Internal resistance:	300 Ω

[1] Observe information on zero potential (→ page 22, §4.4.4)

4.4.3 Installation information for intrinsically safe signal connections

- ▶ Install the signal cables in compliance with EN 60079-11 (“Explosive Atmospheres - Part 11: Equipment protection by intrinsic safety “i””).
- ▶ Maintain electronic limit values (→ page 22, §4.4.4).
- ▶ Install all components of a signal circuit intrinsically safe.



WARNING: Risk of explosions

Intrinsically safe installations must maintain a certain clearance from other electrical equipment (specifications see EN 60079-11).

- ▶ Lay intrinsically safe signal cables so that the required safety distance to equipment not intrinsically safe is ensured everywhere.

4.4.4

Electronic limit values for intrinsically safe signal connections

Intrinsic safety of the connected intrinsically safe signal circuit is only ensured when the power circuit, including cables, maintains the limit values specified below.

**CAUTION: Lower limit values could possibly be applicable**

Lower limit values could be applicable for the individual application case. The composition of the explosive atmosphere is decisive here.

- ▶ Determine the highest allowable limit values for the individual application case using the European standard EN 60079-0 »Explosive atmospheres. Equipment. General requirements«.
- ▶ *If this results in limitations:* Note these limitations (e.g. in this document) and consider during installation.



The Zener barriers used for analog outputs each have 2 channels. One channel is normally used for each analog output. In this case, the analog outputs of a single Zener barrier have a common negative pole (integrated in the Zener barrier) which means they are not separated potential-free from each other.

Limit values for intrinsically safe analog outputs

Parameter of the intrinsically safe power circuit	Allowable value	
	Channel 1/Channel 2	Combined
Total inductivity L_A	$\leq 1.5 \text{ mH}$	$\leq 0.37 \text{ mH}$
Total capacity C_A	$\leq 580 \text{ nF}$	$\leq 580 \text{ nF}$
L_A/R_A	$\leq 61 \mu\text{H}/\Omega$	$\leq 30 \mu\text{H}/\Omega$

Limit values for intrinsically safe digital inputs and digital outputs

Parameter of the intrinsically safe power circuit	Allowable value
Total inductivity L_A	$\leq 4.1 \text{ mH}$
Total capacity C_A	$\leq 83 \text{ nF}$
L_A/R_A	$\leq 54 \mu\text{H}/\Omega$

4.5

Closing the enclosure

- ▶ Check that the upper enclosure section is closed tight. The rotary cover must be fixed with the clamping screw.
- ▶ Close the cover of the lower enclosure section gas-tight.
- ▶ Close off all cable inlets »flame-tight« (gas-tight) (→ page 18, §4.1.3).

GMS820P

5 Operation

Start-up
Operating

5.1

Start-up procedure

- 1 Make sure the enclosure is closed tight (→ page 22, § 4.5).
- 2 Activate the device mains supply at an external source (e.g. main switch).
- 3 Wait until the device is ready for operation (→ “GMS800 Series” Operating Instructions).

5.2

Operating

- ▶ Use the buttons on the lower enclosure section for operation.
- ▶ Do not open the enclosure during operation.

Fig. 4

Basic Control Unit (BCU) buttons

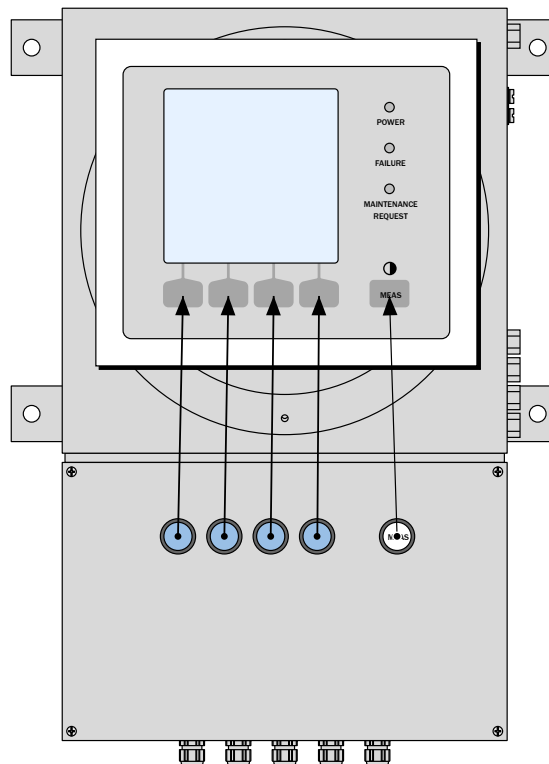

Operating, and operation with, the Basic Control Unit (BCU) → “Basic Control Unit (BCU)” Supplementary Operating Instructions

5.3

Shutting down

Shutdown procedure

- 1 Carry out preparations for shutting down (→ “GMS800 Series” Operating Instructions).
- 2 Disconnect enclosure GMS820P from mains voltage (e.g. switch off the main switch of the host system).

After shutdown



WARNING: Risk of explosions

- ▶ *In potentially explosive atmospheres:* Wait at least 60 minutes after disconnecting the mains voltage before opening the upper enclosure section.
- ▶ Observe the safety information on the enclosure.

GMS820P

6 Maintenance

Leak tightness checks
Checking/replacing flame blocks
Outer cleaning

6.1 Leak tightness checks

6.1.1 Leak tightness check of sample gas lines

If the sample gas path was opened during maintenance work:

- ▶ Check leak tightness of connected sample gas lines after the maintenance work.

If it is suspected that the sample gas path could become leaky during operation (e.g. due to special sample gas properties):

- ▶ Check the leak tightness of the connected sample gas lines in regular intervals.



Leak tightness check procedure → “GMS800 Series” Operating Instructions

6.1.2 Leak tightness check of purge gas paths

Only valid for versions with purge gas connections

- ▶ Check leak tightness of purge gas paths at least once a year.
- ▶ Check in the same manner as for leak tightness of sample gas lines (procedure → “GMS800 Series” Operating Instructions).

6.2 Checking/replacing flame blocks



- A flame block can contaminate like a dust filter and become gas impermeable because the gas permeable part of a flame block is a fine pored metal block (sintered metal). This can occur suddenly or slowly.
- The corresponding gas connection must be disassembled in order to check or replace an integrated flame block. Only have this work done by trained skilled persons. *Recommendation:* Have the work done by the manufacturer's Customer Service.

- ▶ Have the integrated flame blocks checked after the following situations:
 - After an event that could have activated the flame blocks (gas burning)
 - When particles have penetrated the sample gas (e.g. when a dust filter was defective)
- ▶ *When a flame block is in a deficient condition:* Replace the flame block.

6.3 Outer cleaning

To remove dirt from the enclosure:

- ▶ Use a soft cloth. Moisten the cloth with water and a mild detergent when necessary.
- ▶ Do not use mechanically or chemically aggressive cleaning agents.
- ▶ Do not use high-pressure cleaning equipment.

GMS820P

7 Technical Data

Dimensions

Approval

Ambient conditions

Gas connections type

Electrical specifications

7.1 **Dimensions**

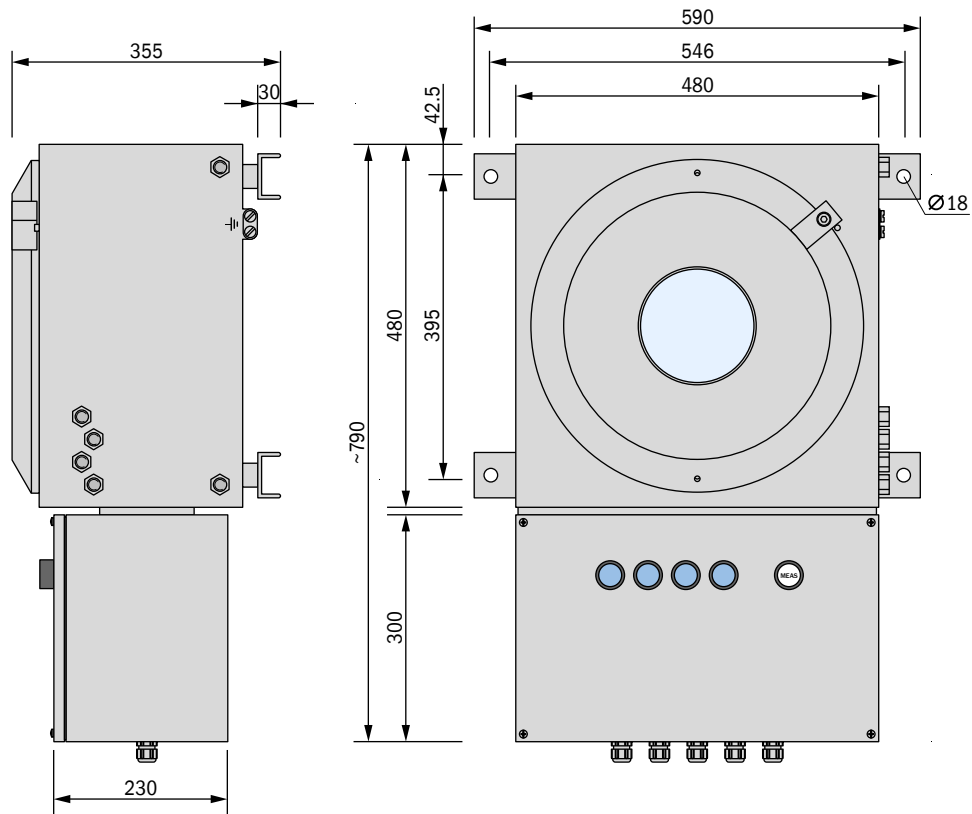

7.2 **Approvals**

Approval type:	EU Type Examination Certificate
Certificate number:	EPS 11 ATEX 1 329 X
Device identification:	II 2G Ex db eb IIC T6 II 2G Ex db eb [ia] IIC T6
Special conditions:	→ page 7, § 1.4

7.3 **Enclosure specifications**

Design	
- Upper enclosure section (analyzer enclosure):	Massive steel + screw cover with window
- Lower enclosure section (connection enclosure)	Sheet steel
- Sections connection:	Cable ducts sealed gas-tight
Degree of protection:	IP 65
Dimensions:	→ page 28, § 7.1
Mass (weight):	124 ... 126 kg ^[1]
Highest surface temperature:	Temperature class T6

[1] Depending on internal equipment

7.4

Ambient conditions

Atmospheric influences:	Only for use indoors
Fitting position (allowable offset):	→ Supplementary Operating Instructions of the Analyzer Module fitted
Geographic height at installation location:	
Ambient air pressure:	
Relative humidity:	10 ... 95%, non-condensing
Ambient temperature during operation:	+5 ... +40 °C (41 ... 113 °F)
Transport /storage temperature:	-10 ... +70 °C (14 ... 158 °F)

7.5

Gas connections

Sample gas connections

Connection	Designation	Suitable for
Standard:	Swagelok 6 mm	Metal tube with 6 mm outer Ø
Option:	Swagelok ¼"	Metal tube with ¼" outer Ø

Approval conditions for sample gas feed

Parameter		Allowable value
Sample gas pressure in enclosure	- For noncombustible sample gases:	-100 ... +1000 hPa (-0.1 ... +1.0 bar)
	- For combustible sample gases:	-100 ... +100 hPa (-0.1 ... +0.1 bar)
	- For combustible sample gases, with enclosure venting (option ^[1]):	-100 ... +1000 hPa (-0.1 ... +1.0 bar)
Sample gas volume flow ^[2] :	- Standard:	Max. 100 dm ³ /hour ^[3] ^[4]
	- With enclosure venting (option ^[1]):	Max. 70 dm ³ /hour ^[3] ^[4]

[1] → page 15, §3.3.4

[2] At sample gas inlet of enclosure.

[3] However, give priority to maintaining the allowable sample gas pressure in the enclosure.

[4] Recommendation: Max. 60 dm³/hour.

Purge gas feed for an Analyzer module

Parameter	Allowable value
Maximum purge gas pressure in enclosure:	15 hPa (15 mbar)



- Gas connection positions → page 14, Fig. 2
- Checking/replacing integrated flame blocks → page 26, § 6.2
- Sample gas connections function → "GMS800 Series" Operating Instructions
- Other specifications → Supplementary Operating Instructions of the Analyzer module fitted

7.6 **Mains connection**

Mains voltage (optional):	93 ... 132 V AC, 47 ... 63 Hz
	186 ... 264 V AC, 47 ... 63 Hz
	210 ... 370 V DC
Allowable overvoltages:	Transient overvoltages in supply network must not exceed Overvoltage Category II according to IEC 60364-4-443
Power input:	50 VA / max. 300 VA
Internal mains fuses	
- Primary:	6.3 A (not exchangeable) [1]
- Secondary:	8 A (exchangeable fusible cutout) [2]

[1] Replace the power supply unit after triggering

[2] F1 on the fuse board – spare part: “Fuse link FF8A0 250V D5x20”, Part No. 6004313

7.7 **Electrical safety**

Protection class:	Protection class I [1]
Electrical safety:	Tested according to EN 61010-1 Low Voltage Directive 2006/95/EC
Transformer:	Safety transformer according to EN 61558 (VDE 0570)
Electromagnetic compatibility:	In accordance with EN 61326-1, EN 61326-2-1, EN 61000-6-2, EN 61000-6-4 and Directive 2004/ 108/EC

[1] VDE 0411 Part 1 / IEC 348

... Empty page ...

A		F	
Additional documentation (information)	7	Flame blocks, checking/replacing	26
Alarm settings, intrinsically safe signal connections	22	G	
Ambient conditions	13, 29	Gas connection for enclosure venting	15
Application limitations	7	Gas connections	
Approval conditions		- Position	28
- Application limitations	7	- Sample gas connections	15
- Gas feed	29	- Technical data	29
Approvals	28	Glossary	2
Assembly	13	I	
Atmosphere	29	Identification	28
Atmosphere (at installation location)	13	Important information	
B		- Main hazards	6
Bonding load connection	19	- Main operating information	6
Buttons	24	Inductivity (intrinsically safe signal connections)	22
C		Information symbols	2
Cable inlets	18	Installation	
Cables		- General safety information	6
- Cables, suitable	18	- Intrinsically safe signal connections	21
- Diameter, suitable	18	- Mains connection	15, 19
- For intrinsically safe signal connections	21	- Potential equalization	19
- Installation (general)	18	- Signal connections	20
Capacity (intrinsically safe signal connections)	22	Intrinsically safe signal connections	21
Carbon disulfide (CS ₂)	7, 13	- Allowable capacity/inductivity	22
Cleaning	26	- Cable installation	21
Climate (at installation location)	13	- Electronic limit values	22
Connections		- Potential-free separation (information)	22
- Mains connection	19	- Special technical data	21
- Potential equalization (PA)	19	- Technical layout	21
- Sample gas connections	15	L	
- Signal connections	20	Leak tightness checks	26
- Terminal assignment	19	LEL (application limitation)	7, 13
CS ₂	13	Lifting points	12
D		M	
Degree of protection	28	Main connection (electric)	19
Delay time after switching off	6, 24	Main electrical connection	19
Dimensions	28	Mains connection	
E		- Installation, terminal assignment	19
Earth (potential equalization)	19	- Technical data	30
Enclosure venting	15	Maintenance	
Enclosure, opening		- Flame blocks	26
- Delay time after switching off	18	- Leak tightness checks	26
- Protective measures before opening	12, 18	- Outer cleaning	26
Enclosure, sealing	22	Mass	28
EU Type Examination Certificate	28		

O

Opening the enclosure	
- Delay time after switching off	6
Operating	24
Options	10

P

PG screw fittings (cable inlets)	18
Potential equalization (earth)	19
Product description	9 - 10
Purge gas	
- Regular leak tightness check	26
Purge gas connections	15
purge in, purge out (gas connections)	15
Push buttons	24

S

Safety during installation and repairs	6
Safety information	
- Enclosure, opening	18
- Protection against dangerous sample gases	12
- Transport and assembly	12
Sample gas	
- Approval conditions	29
- Connections	15
- Leak tightness check	26
Screw fittings (technical data)	29
Shutdown	24
Signal connections	
- Intrinsically safe signal connections	21
- Terminal assignment	20
Signal words	2
Special conditions	7
Specifications	27
Start-up	24
Surface temperature	28
Swagelok	29
Switching off (Delay time before opening)	6
Switch-off (delay time before opening)	24
Symbols (explanation)	2

T

Technical data	
- Ambient conditions	29
- Electrical safety	30
- Enclosure specifications	28
- For intrinsically safe signal connections	21 - 22
- Gas connections	29
Temperature	29
Terminal assignment	
- Mains connection	19
- Signal connections	20

V

Venting (opening/gas connection)	15
Vibrations	13

W

Warning symbols, warning levels	2
Weight	28

Z

Zener barriers	21
----------------	----

GMS820P

8015934/V 1.0/2012-07 | Subject to change without notice

SICK worldwide

You will find our local subsidiary
or agency at:
www.sick.com

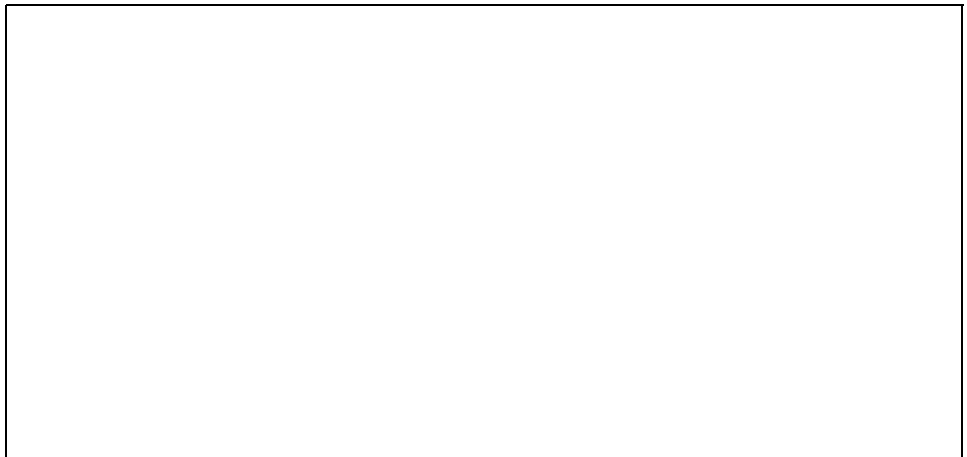

Your local sales and service partner