

LD-LRS1000 to 5100
Laser Measurement System



Long Range



Software version described

Software/tool	Function	Status
LD-LRSXXX	Firmware	V 2.4.0 or higher
Device description LD-LRS_XXX_AP01	Device specific software module for SOPAS ET	V 1.0 or higher
SOPAS ET	Configuration software	V 02.18 or higher

NOTICE

The LD-LRS laser measurement system is intended for use in industrial environments. When used in residential areas, it can cause radio interferences.

Copyright

Copyright © 2008
SICK AG Waldkirch
Auto Ident, Reute Plant
Nimburger Straße 11
79276 Reute
Germany

Trademarks

Windows 2000™, Windows XP™, Windows Vista™ and Internet Explorer™ are registered trademarks of Microsoft Corporation in the USA and other countries.

Acrobat® Reader™ is a trademark of Adobe Systems Incorporated.

Version of the operating instructions

The latest version of these operating instructions can be obtained as PDF at www.sick.com.

Table of contents

1	About this document	8
1.1	Function of this document	8
1.2	Target group	8
1.3	Depth of information	8
1.4	Symbology used	9
2	For your safety	10
2.1	Authorised personnel	10
2.2	Correct use	10
2.3	General safety notes and protective measures	11
2.4	Quick stop and Quick restart	14
2.5	Environmental protection	14
3	Product description	15
3.1	Delivery	15
3.2	Device variants	16
3.3	Special features of the LD-LRS	17
3.4	Operating principle of the LD-LRS	18
3.5	Applications	26
3.6	Measured value output (raw data)	26
3.7	Field application	27
3.8	Custom application	30
3.9	Data interfaces	30
3.10	Switching outputs	32
3.11	Controls and status indicators	33
3.12	Planning	34
4	Mounting	37
4.1	Overview of the mounting steps	37
4.2	Preparations for mounting	37
4.3	Mounting and adjustment of the device	38
4.4	Dismanteling the system	42
5	Electrical installation	43
5.1	Overview of the installation steps	43
5.2	Connections of the LD-LRS	44
5.3	Preparing the electrical installation	49
5.4	Undertaking electrical installation on the LD-LRS1000	51
5.5	Undertaking electrical installation on the LD-LRSx100	56
6	Commissioning and configuration	58
6.1	Overview of the commissioning steps	58
6.2	SOPAS ET configuration software	58
6.3	Establish communication with the LD-LRS	59
6.4	Initial commissioning	61
6.5	Performing the configuration	62
6.6	Connection and test measurement	62
7	Maintenance	63
7.1	Maintenance during operation	63
7.2	Disposal	64
7.3	Replacement of a system or replacement of components	65

8	Troubleshooting	67
8.1	In the event of faults or errors	67
8.2	Monitoring error and malfunction indications	67
8.3	Troubleshooting and rectification	68
8.4	Detailed error analysis	68
9	Technical specifications	70
9.1	Data sheet LD-LRS laser measurement system	70
9.2	Response times	72
9.3	Dimensional drawings	73
10	Annex	78
10.1	Overview of the annexes	78
10.2	Data communication via the data interfaces	78
10.3	Ordering information	89
10.4	Glossary	91
10.5	Illustration containing the EC Declaration of conformity	92

Abbreviations

BCC	Block character check
CAN	Controller area network = standardised fieldbus system with message-based protocol for exchanging data
CS	Checksum
DSP	Digital signal processor = digital signal processor for internal data processing using application software
HTML	Hypertext markup language = page description language on the Internet
LD-LRS	Ladar long range laser scanner = laser measurement system with large scanning range, based on so-called Ladar technology (Ladar = laser emitting radar)
LED	Light emitting diode
RAM	Random access memory = volatile memory with direct access
ROM	Read-only memory (permanent)
SOPAS ET	SICK OPEN PORTAL for APPLICATION and SYSTEMS ENGINEERING TOOL = configuration software for the configuration of the LD-LRS
UPF	User protocol frame
USP	User services protocol = protocol for user-programmed evaluation

Tables

Tab. 1:	Target groups of this document	8
Tab. 2:	Authorised personnel	10
Tab. 3:	Delivery	15
Tab. 4:	Device variants	16
Tab. 5:	Special features of the LD-LRS variants	17
Tab. 6:	Typical reflection values and scanning ranges	21
Tab. 7:	Typical settings for the LD-LRS	25
Tab. 8:	Maximum output current on the switching outputs	32
Tab. 9:	Characteristic data for the switching outputs	32
Tab. 10:	Characteristic data for the relay outputs	33
Tab. 11:	Significance of the LEDs	34
Tab. 12:	Beam diameter at different distances from the laser measurement system ...	36
Tab. 13:	Function of the DIP switches	44
Tab. 14:	Assignment for the 6-way terminal block	45
Tab. 15:	Pin -assignment for the 15 pin D-Sub HD plug	45
Tab. 16:	LD-LRS2100: assignment of the 20 pin Harting plugs	46
Tab. 17:	LD-LRS3100: assignment of the 20 pin Harting plugs	47
Tab. 18:	LD-LRS4100: assignment of the 20 pin Harting plugs	48
Tab. 19:	LD-LRS5100: assignment of the 20 pin Harting plugs	49
Tab. 20:	Maximum cable lengths for the supply voltage	50
Tab. 21:	Maximum cable lengths for the data interfaces	50
Tab. 22:	Pre-assembled cable for LD-LRS1000	54
Tab. 23:	Pin assignment for the RS-232 null modem cable Part No. 6032508	54

Tab. 24:	Pin assignment Ethernet cross-over cable Part No. 6032509	55
Tab. 25:	Pre-assembled cable for LD-LRSx100	56
Tab. 26:	Configuration cable pin assignment Part No. 6032770	56
Tab. 27:	SOPAS ET default setting	59
Tab. 28:	Connect the data interfaces	59
Tab. 29:	Passwords	62
Tab. 30:	Troubleshooting and rectification	68
Tab. 31:	Data sheet LD-LRS laser measurement system	70
Tab. 32:	Scan times	72
Tab. 33:	Physical response times of the outputs	72
Tab. 34:	Data communication: terminology	78
Tab. 35:	Data communication: frame format	79
Tab. 36:	Data communication: example for packing a BYTE string in the big endian format	79
Tab. 37:	Data communication: header format for the first UPF packet in a packet sequence	80
Tab. 38:	Data communication: header format for the following UPF packets in a packet sequence	80
Tab. 39:	Data communication: header format for a UPF packet sequence comprising a single packet	80
Tab. 40:	Data communication: example for the packet breakdown	80
Tab. 41:	RS-232/RS-422 interface: IF packet format	81
Tab. 42:	RS-232/RS-422 interface: number of bytes in the complete IF packet	81
Tab. 43:	CAN interface: format of the first UPF packet in a packet sequence	83
Tab. 44:	CAN interface: format of the following UPF packets in a packet sequence	83
Tab. 45:	CAN interface: format for a single packet sequence	83
Tab. 46:	CAN communication parameter: timing parameter	84
Tab. 47:	Available systems	89
Tab. 48:	Available accessories	90

Figures

Fig. 1:	Laser output aperture in the rotating scanner head on the LD-LRS1000	13
Fig. 2:	Laser output aperture on the LD-LRSx100	13
Fig. 3:	LD-LRS variants	16
Fig. 4:	Measuring principle of the LD-LRS	18
Fig. 5:	Depiction of the measured result	18
Fig. 6:	Reflection of the laser beam at the surface of an object	19
Fig. 7:	Reflection angle	20
Fig. 8:	Degree of reflection	20
Fig. 9:	Mirror surfaces	20
Fig. 10:	Object smaller than diameter of the laser beam	21
Fig. 11:	Schematic layout of the distance between measured points at different angular resolutions	22

Fig. 12:	Beam diameter and distance between measured points at 0 to 80 m (0 to 262.47 ft)	22
Fig. 13:	Beam diameter and distance between measured points at 0 to 250 m (0 to 820.21 ft)	23
Fig. 14:	Minimum object size for detection	24
Fig. 15:	Principle of the field application	27
Fig. 16:	Examples of different shapes for the evaluation field	29
Fig. 17:	Increase in the size of the beam and safety supplement	35
Fig. 18:	Fixing bracket LD-LRS1000	39
Fig. 19:	Fixing bracket LD-LRSx100	40
Fig. 20:	Mast bracket LD-LRSx100	40
Fig. 21:	Mounting the LD-LRSx100 on the mast	41
Fig. 22:	Incorrect placement of two LD-LRS	41
Fig. 23:	Allowed placement of two LD-LRS with shielding	42
Fig. 24:	Allowed placement of two LD-LRS with vertical offset	42
Fig. 25:	Allowed placement of two LD-LRS with directional offset	42
Fig. 26:	LD-LRS1000: layout of the interface adapter	44
Fig. 27:	Housing for the 20 pin connection with Harting socket	46
Fig. 28:	Connecting supply voltage	51
Fig. 29:	Wiring switching outputs	52
Fig. 30:	Wiring relay outputs	52
Fig. 31:	Wiring of the CAN interface	53
Fig. 32:	Wiring the RS-232 interface	53
Fig. 33:	Wiring the RS-422 interface	53
Fig. 34:	LD-LRS1000: RS-232 connection using null modem cable part no. 6032508	54
Fig. 35:	LD-LRS1000: Ethernet connection using the Ethernet cross-over cable part no. 6032509 ..	55
Fig. 36:	LD-LRSx100: RS-232 connection using the configuration cable part no. 6032770	57
Fig. 37:	LD-LRSx100: Ethernet connection using the configuration cable part no. 6032770	57
Fig. 38:	RJ-45 connector	57
Fig. 39:	Principle of data storage	61
Fig. 40:	Optics for the LD-LRS1000 or cover for the LD-LRSx100	64
Fig. 41:	Position of the desiccant cartridge	65
Fig. 42:	Dimensional drawing LD-LRS1000	73
Fig. 43:	Dimensional drawing LD-LRS2100, 3100, 4100 and 5100	74
Fig. 44:	Dimensional drawing bracket for LD-LRS1000	75
Fig. 45:	Dimensional drawing bracket for LD-LRS 2100, 3100, 4100 and 5100	76
Fig. 46:	Dimensional drawing mast bracket for LD-LRS 2100, 3100, 4100 and 5100	77
Fig. 47:	Structure of the UPF packet in the user service protocol	82
Fig. 48:	Illustration containing the EC Declaration of conformity	92

1 About this document

Please read this chapter carefully before working with this documentation and the LD-LRS laser measurement system.

1.1 Function of this document

These operating instructions are designed to **address the technical personnel** in regards to safe mounting, installation, configuration, electrical installation, commissioning, operation and maintenance of the following LD-LRS laser measurement system variants:

- LD-LRS1000
- LD-LRS2100
- LD-LRS3100
- LD-LRS4100
- LD-LRS5100

All device variants are shown in [section 3.2 “Device variants” on page 16](#).

In the following the LD-LRS variants 1000, 2100, 3100, 4100 and 5100 are referred to as LD-LRS for short. If required, the LD-LRS variants 2100, 3100, 4100 and 5100 are summarized and referred to as LD-LRSx100.

1.2 Target group

The intended audience for this document is people in the following positions:

Activities	Target group
Mounting, electrical installation, maintenance and replacement	Factory electricians and service engineers
Commissioning, operation and configuration	Technicians and engineers

Tab. 1: Target groups of this document

1.3 Depth of information

These operating instructions contain the following information on the LD-LRS:

- mounting
- electrical installation
- commissioning and configuration
- maintenance
- fault, error diagnosis and troubleshooting
- ordering information
- conformity and approval

Planning and using laser measurement systems such as the LD-LRS also require specific technical skills which are not detailed in this documentation.

In addition, online help is available in SOPAS ET configuration software supplied; this help provides information on the usage of the software user interface, as well as on the configuration of the LD-LRS.

More detailed information on the LD-LRS is available from SICK AG, Division Auto Ident. On the internet at www.sick.com.

1.4 Symbology used

Recommendation	Recommendations are designed to give you assistance in the decision-making process with respect to a certain function or a technical measure.
Important	Sections marked "Important" provide information about special features of the device.
Explanation	Explanations provide background knowledge on technical relationships.
MENU COMMAND	This typeface indicates a term in the SOPAS ET user interface.
Terminal output	This typeface indicates messages that the LD-LRS outputs via its terminal interface.
➤ Take action ...	Instructions for taking action are shown by an arrow. Read carefully and follow the instructions for action.



This symbol refers to additionally available documentation.

NOTICE

Note!

A note provides indicates potential hazards that could involve damage or degradation of the functionality of the LD-LRS or other devices.



WARNING

Warning!

A warning indicates an actual or potential hazard. They are designed to help you to prevent accidents.

The safety symbol beside the warning indicates the nature of the risk of accident, e.g. due to electricity. The warning category (DANGER, WARNING, CAUTION) indicates the severity of the hazard.

- Read carefully and follow the warning notices!



Software notes show where you can make the appropriate settings and adjustments in the SOPAS ET configuration software.

2 For your safety

This chapter deals with your own safety and the safety of the equipment operators.

- Please read this chapter carefully before working with the LD-LRS.

2.1 Authorised personnel

The LD-LRS laser measurement system must only be installed, commissioned and serviced by adequately qualified personnel.

NOTICE

Repairs to the LD-LRS are only allowed to be undertaken by trained and authorised service personnel from SICK AG.

The following qualifications are necessary for the various tasks:

Activities	Qualification
Mounting and maintenance	<ul style="list-style-type: none"> • basic technical training • knowledge of the current safety regulations in the workplace
Electrical installation and replacement	<ul style="list-style-type: none"> • practical electrical training • knowledge of current electrical safety regulations • knowledge on the use and operation of devices in the related application (e.g. conveyors)
Commissioning, operation and configuration	<ul style="list-style-type: none"> • knowledge on the use and operation of devices in the related application (e.g. conveyors) • knowledge on the software and hardware environment in the related application (e.g. conveyors) • basic knowledge of the Windows operating system • basic knowledge of the usage of an HTML browser (e.g. Internet Explorer) • basic knowledge of data transmission

Tab. 2: Authorised personnel

2.2 Correct use

NOTICE

The LD-LRS laser measurement system is intended for use in industrial environments. When used in residential areas, it can cause radio interferences.

The LD-LRS is an electro-sensitive distance measurement system for stand-alone or network operation. It is suitable for applications in which precise, electro-sensitive measurements of contours and surroundings are required. It is also possible to realise systems, for instance, for collision protection, for building surveillance or for access monitoring.

It must be initialised only by qualified personnel and only in industrial environments.

NOTICE

In case of any other usage as well as in case of modifications to the LD-LRS, e.g. due to opening the housing during mounting and electrical installation, or to the SICK software, any claims against SICK AG under the warranty will be rendered void.

The LD-LRS is only allowed to be operated in the ambient temperature range allowed (see [section 9.1 “Data sheet LD-LRS laser measurement system” on page 70](#)).

Compatibility to devices with older firmware versions

The parameter sets for a LD-LRS with a firmware version lower than V 2.4 saved in a SOPAS ET project cannot be transferred to devices with a firmware version from V 2.4.

2.3 General safety notes and protective measures

WARNING



Safety notes

Please observe the following items in order to ensure the correct and safe use of the LD-LRS.

- The notices in these operating instructions (e.g. on use, mounting, installation or integration into the existing machine controller) must be observed.
- When operating the LD-LRS, the national, local and statutory rules and regulations must be observed.
- National/international rules and regulations apply to the installation, commissioning, use and periodic technical inspections of the laser measurement system, in particular:
 - work safety regulations/safety rules
 - other relevant health and safety regulations
- Manufacturers and operators of the system are responsible for obtaining and observing all applicable safety regulations and rules.
- The tests must be carried out by specialist personnel or specially qualified and authorised personnel and must be recorded and documented to ensure that the tests can be reconstructed and retraced at any time.
- The operating instructions must be made available to the operator of the system where the LD-LRS is used. The operator of the system is to be instructed in the use of the device by specialist personnel and must be instructed to read the operating instructions.
- The LD-LRS is not a device for the protection of people in the context of the related safety standards for machinery.

2.3.1 Electrical installation work

NOTICE

- Electrical installation work is only allowed to be undertaken by authorised personnel.
- Only make and disconnect electrical connections when the device is electrically isolated.
- Select and implement wire cross-sections and their correct fuse protection as per the applicable standards.
- Do not open the housing.
- Observe the current safety regulations when working on electrical systems.

2.3.2 Laser radiation of the laser measurement system



CAUTION

Laser radiation!

The LD-LRS operates with an infrared laser of class 1 (eye safe). The laser beam cannot be seen with the human eye.

- Incorrect usage can result in hazardous exposure to laser radiation.
- Do not open the housing (opening the housing will not switch off the laser).
- Pay attention to the laser safety regulations as per IEC 60825-1 (latest version), complies with 21 CFR 1040.10 with the exception of the deviations as per Laser Notice No. 50, July 26, 2001.

Increased laser radiation if scanner head broken off!

The rotating scanner head (see [Fig. 1 on page 13](#)) on the LD-LRS1000 is equipped with defined fracture points to prevent damage to the internal mechanism in case of a heavy impact on the scanner head.

If the scanner head is broken off, the LD-LRS is categorised as laser class 1M.

- Do not look into the open output aperture for the laser beam, also not with optical instruments.
- Immediately switch off the device and secure against placing back in operation.

Important No maintenance is necessary to ensure compliance with laser class 1.

Laser output aperture

The laser output aperture is the round optic in the rotating scanner head on the LD-LRS1000 or the cover on the LD-LRSx100.



Fig. 1: Laser output aperture in the rotating scanner head on the LD-LRS1000



Fig. 2: Laser output aperture on the LD-LRSx100

Laser power

The laser operates at a wavelength $\lambda = 905 \text{ nm}$ (invisible infrared light). The radiation emitted in normal operation is not harmful to the eyes and human skin.

2.4 Quick stop and Quick restart

2.4.1 Switching the LD-LRS off

- Switch off the voltage supply for the LD-LRS or disconnect the supply cable.

The LD-LRS retains parameters stored in the internal, non-volatile memory. Measured values on the interface are lost.

2.4.2 Switching the LD-LRS on again

- Switch on the voltage supply for the LD-LRS or reconnect the supply cable.

The LD-LRS restarts operation with the last saved parameters.

2.5 Environmental protection

The LD-LRS has been designed to minimise environmental impact. It uses only a minimum of power.

While working, always act in an environmentally responsible manner. For this reason please note the following information on disposal.

2.5.1 Power consumption

- The LD-LRS1000 draws a maximum of 36 W in operation (however, on power up the power supply must be able to briefly supply 2.1 A/51 W).
- LD-LRSx100 also draw in addition a maximum of 144 W in cycles for the heating.

2.5.2 Disposal after final de-commissioning

- Always dispose of unserviceable or irreparable devices in compliance with local/national rules and regulations on waste disposal.
- Dispose of all electronic assemblies as hazardous waste. The electronic assemblies are straightforward to dismantle.

See section [7.2 “Disposal” on page 64](#).

Important SICK AG does not accept unusable or irreparable devices that are returned.

3 Product description

This chapter provides information on the special features and properties of the LD-LRS laser measurement system. It describes the construction and the operating principle of the device, in particular the different operating modes.

Please read this chapter before mounting, installing and commissioning the device.

3.1 Delivery

The LD-LRS delivery includes the following components:

Quantity	Components	Comment
1	A LD-LRS laser measurement system	LD-LRS1000, LD-LRS2100, LD-LRS3100, LD-LRS4100 or LD-LRS5100, depending on order
1	CD-ROM "Manuals & Software Auto Ident"	Contents see 3.1.1
1	Lens cloth	

Tab. 3: Delivery

[Section 10.3 "Ordering information" on page 89](#) provides an overview of the systems available and the accessories available.

3.1.1 Contents of the CD-ROM

- SOPAS ET configuration software
- operating instructions "LD-LRS laser measurement system" in German and English as PDF
- message listing "LD-LRS laser measurement system" in English as PDF-output
- freely available software "Adobe Acrobat® Reader™"

The latest versions of the publications and programs included on the CD-ROM are also available for download at www.sick.com.

3.2 Device variants

Type	Data interfaces	Outputs	Enclosure rating
LD-LRS1000	CAN, Ethernet, RS-232, RS-422	Digital	IP 65
LD-LRS2100	CAN, Ethernet, RS-232	Digital	IP 67
LD-LRS3100	CAN, Ethernet, RS-422	Digital	IP 67
LD-LRS4100	CAN, Ethernet, RS-232	Relay/digital	IP 67
LD-LRS5100	CAN, Ethernet, RS-422	Relay/digital	IP 67

Tab. 4: Device variants



Fig. 3: LD-LRS variants

3.3 Special features of the LD-LRS

Variant	Special features
All	<ul style="list-style-type: none"> • electro-sensitive, active measurement technique • scanning range up to 250 m (820.21 ft) • resolution of the angular step width: maximum 0.125° • scanner head rotational frequency 5...10 Hz (can be selected in 1-Hz steps) • max. pulse frequency of the laser diode 14.4 kHz • flexible system configurations • configuration/measured value request using user protocol services (command strings) <p>Measured value output (raw data)</p> <ul style="list-style-type: none"> • profile of the field of view in two-dimensional polar co-ordinates, as hex values • contents of one revolution (360°): incl. number of the profile emitted, profile counter, sector numbers, step width, number of points per sector, time stamp for start/end of each sector, direction at the start/end of each sector, value and direction of the distances measured, status <p>Integrated field application</p> <ul style="list-style-type: none"> • four evaluation fields can be configured; these fields are allocated to the digital outputs or the relay outputs on the LD-LRS • contour monitoring <p>User programmable evaluations</p> <ul style="list-style-type: none"> • A user programmed evaluation can be implemented with the aid of the user protocol services in the integrated DSP.
LD-LRS1000	<ul style="list-style-type: none"> • field of view maximum 360° • data interfaces CAN, Ethernet, RS-232 (default)/RS-422 • 4 digital outputs
LD-LRS2100	<ul style="list-style-type: none"> • field of view maximum 300° • protective housing with heating (IP 67) • data interfaces CAN, Ethernet, RS-232 • 4 digital outputs
LD-LRS3100	<ul style="list-style-type: none"> • field of view maximum 300° • protective housing with heating (IP 67) • data interfaces CAN, Ethernet, RS-422 • 4 digital outputs
LD-LRS4100	<ul style="list-style-type: none"> • field of view maximum 300° • protective housing with heating (IP 67) • data interfaces CAN, Ethernet, RS-232 • 2 relay outputs, 1 digital output
LD-LRS5100	<ul style="list-style-type: none"> • field of view maximum 300° • protective housing with heating (IP 67) • data interfaces CAN, Ethernet, RS-422 • 2 relay outputs, 1 digital output

Tab. 5: Special features of the LD-LRS variants

3.4 Operating principle of the LD-LRS

The LD-LRS is an electro-optical laser measurement system that electro-sensitively scans the perimeter of its surroundings in a plane with the aid of laser beams. The LD-LRS measures its surroundings in two-dimensional polar co-ordinates. If a measuring beam is incident on an object, the position is determined in the form of distance and direction.

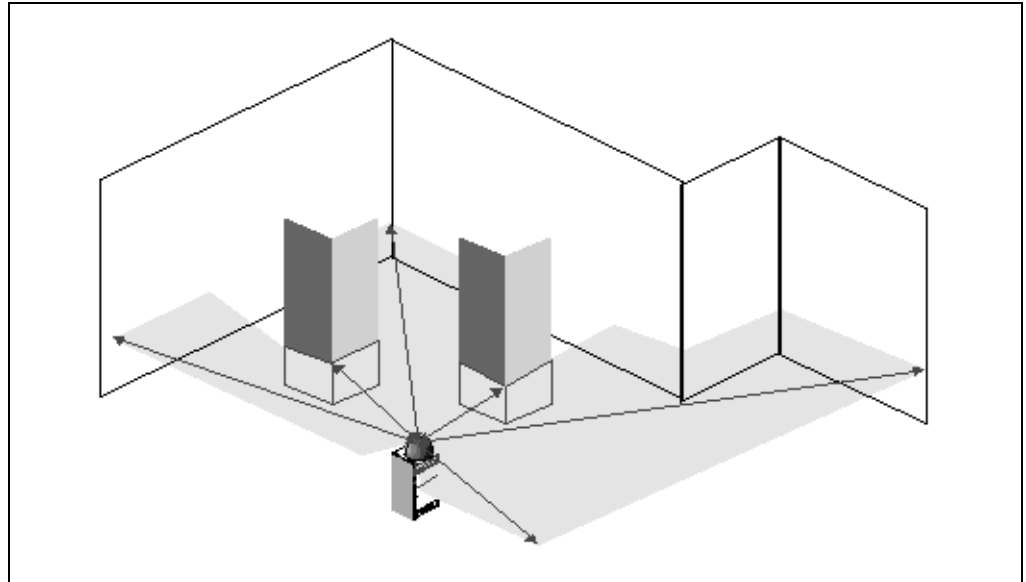

Fig. 4: Measuring principle of the LD-LRS

Scanning takes place in a sector of 360° or 300°. The scanning ranges of the sensors are for the LD-LRS approx. 250 m (820.21 ft) on light, natural surfaces (e.g. a white house wall).

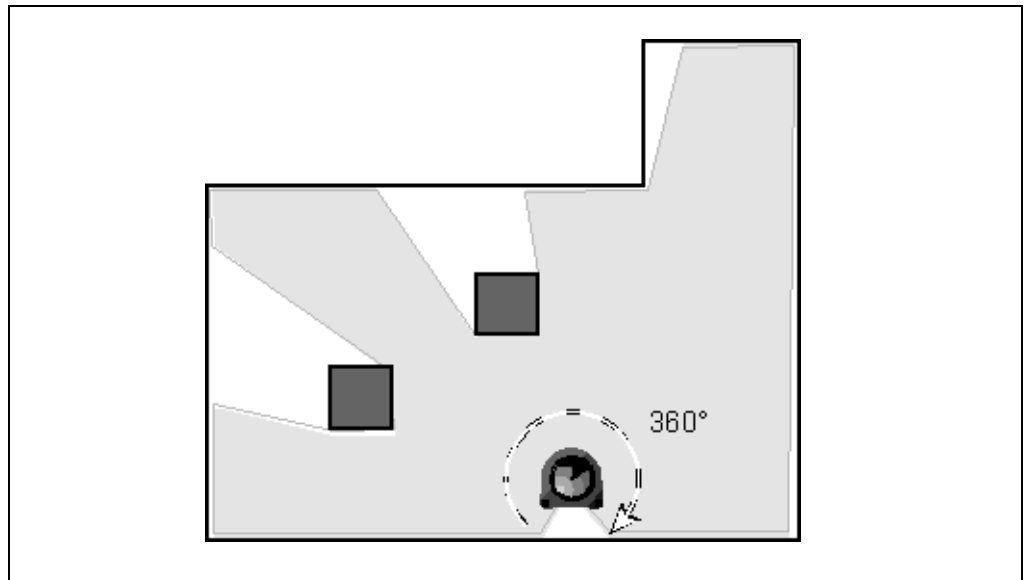

Fig. 5: Depiction of the measured result

Distance measurement

The LD-LRS emits pulsed laser beams using a laser diode. If such a laser pulse is incident on an object, it is reflected at its surface. The reflection is detected in the laser measurement system's receiver using a photodiode.

The distance to the object is calculated from the propagation time that the light requires from emission to reception of the reflection at the sensor.

This principle of “pulse propagation time measurement” is used by radar systems in a similar manner.

The laser beams emitted are deflected using a mirror in the scanner head and scan the surroundings in a circular manner. The measurements are triggered at regular angular steps using an angular encoder.

Direction measurement

The scanner head rotates at a selectable frequency of from 5 to 10 Hz. During this process, a laser pulse and therefore a distance measurement is triggered after an angular step of e.g. 0.25° (adjustable). The maximum angular resolution is 0.125° . This angle is defined by the angular encoder with 5760 steps. The angular resolution can be selected as an integer multiple of 0.125° .

NOTICE

- Within the maximum scanning range area of 360° , the average pulse frequency of 10.8 kHz is not allowed to be exceeded (see also [section 3.4.4 “Maximum and mean pulse frequency” on page 24](#)).
- The maximum pulse frequency is not allowed to exceed 14.4 kHz (see also [section 3.4.4 “Maximum and mean pulse frequency” on page 24](#)).
- The minimum time between 2 laser pulses is 70 ms (corresponds to 14.4 kHz).

Influences of object surfaces on the measurement

The signal received from a perfectly diffuse reflecting white surface corresponds to the definition of a remission of 100%. As a result of this definition, the remissions for surfaces that reflect the light bundled (mirrored surfaces, reflectors), are more than 100%.

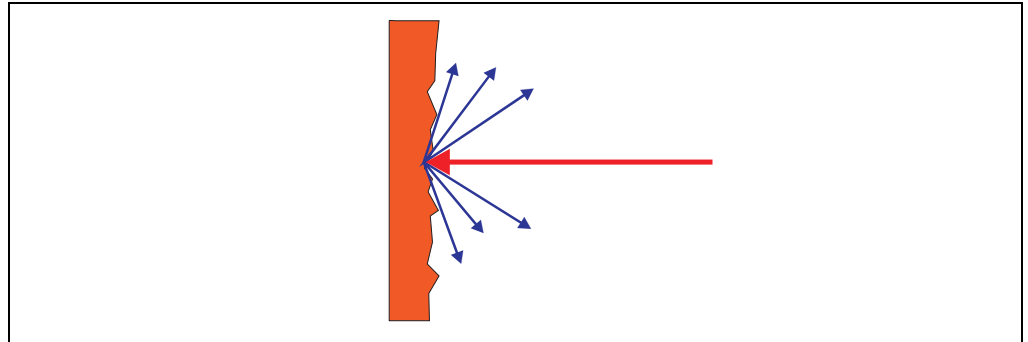

Fig. 6: Reflection of the laser beam at the surface of an object

The majority of surfaces reflect the laser beam diffusely in all directions.

The reflection of the laser beam will vary as a function of the surface structure and colour. Light surfaces reflect the laser beam better than dark surfaces and can be detected by the LD-LRS over larger distances. Brilliant white plaster reflects approx. 100% of the incident light, black foam rubber approx. 2.4%. On very rough surfaces, part of the energy is lost due to shading. The scanning range of the LD-LRS will be reduced as a result.

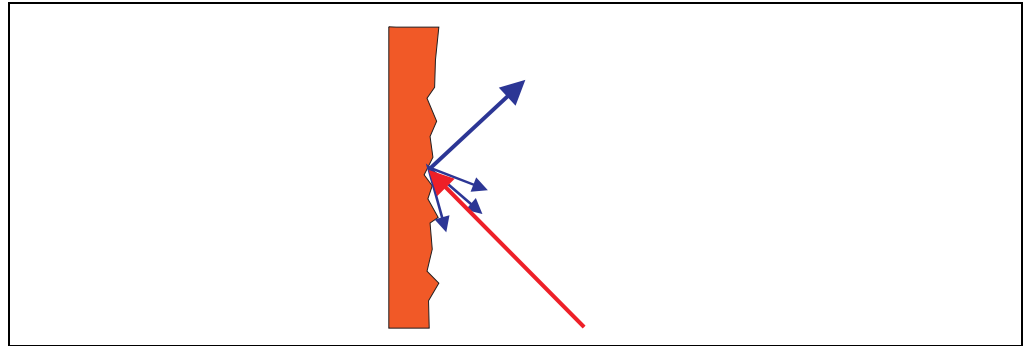

Fig. 7: Reflection angle

The reflection angle is the same as the angle of incidence. If the laser beam is incident perpendicularly on a surface, the energy is optimally reflected (Fig. 6 on page 19). If the beam is incident at an angle, a corresponding energy and scanning range loss is incurred (Fig. 7 on page 20).

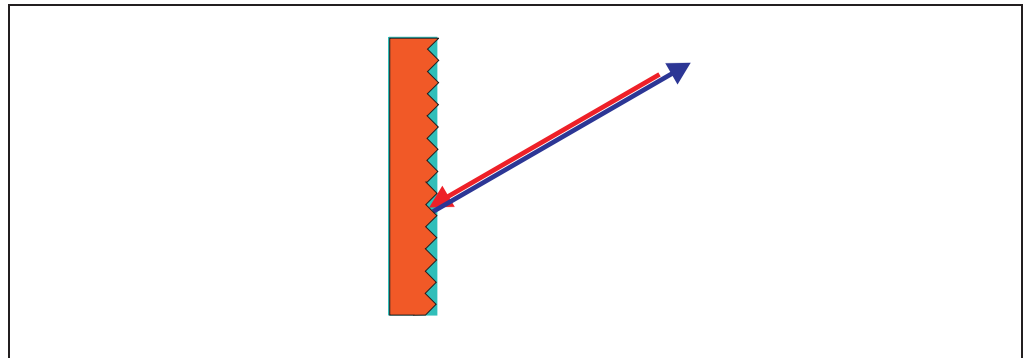

Fig. 8: Degree of reflection

If the reflected energy returned is over 100% (basis: Kodak standard) the incident beam is not reflected diffusely in all directions, but is reflected in a specific direction. As a result a large portion of the energy emitted can be received by the laser distance measurement device. Plastic reflectors (“cats’ eyes”), reflective tape and triple prisms have these properties.

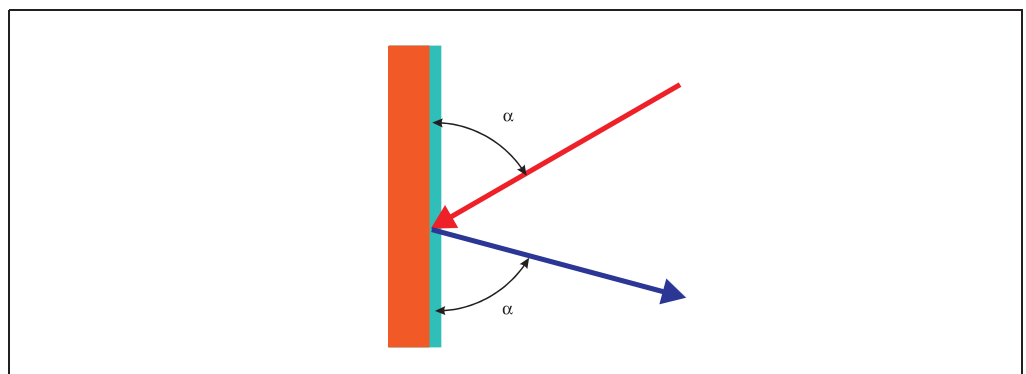

Fig. 9: Mirror surfaces

At mirror surfaces the laser beam is almost entirely deflected (Fig. 9 on page 20).

Instead of the surface of the mirror, it is possible that the object on which the deflected laser beam is incident may be detected.

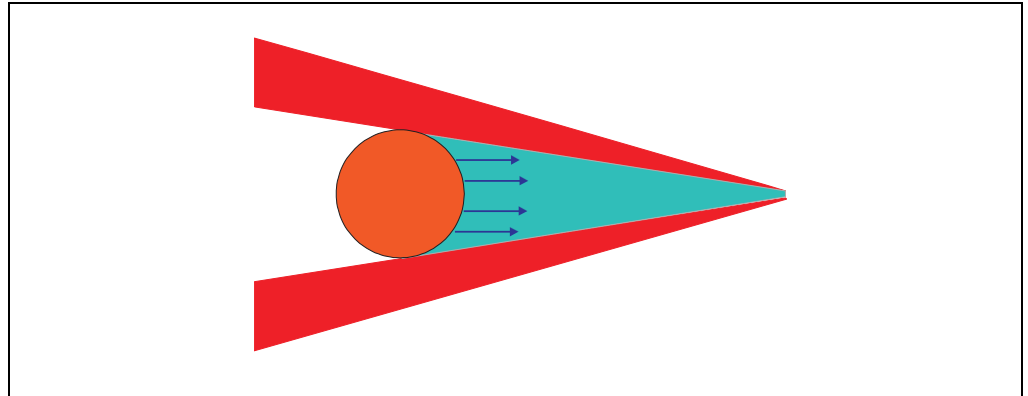

Fig. 10: Object smaller than diameter of the laser beam

Objects that are smaller than the diameter of the laser beam cannot reflect all the energy of the laser light (Fig. 10 on page 21). The energy in the portion of the laser light that is not reflected is lost. This means that the scanning range is less than would be possible theoretically based on the surface of the object.

3.4.1 Scanning range of the LD-LRS

The scanning range of the LD-LRS is dependent on the remission of the objects to be detected. The better a surface reflects the incident radiation, the greater the scanning range of the LD-LRS.

Material	Remission	Measurement area LD-LRS1000	Measurement area LD-LRSx100
Black car paint, matt	5%	0.5...56 m (1.64...183.73 ft)	2.5...56 m (8.2...183.73 ft)
Black photographic cardboard, matt	10%	0.5...80 m (1.64...262.47 ft)	2.5...80 m (8.2...262.47 ft)
Grey concrete	18%	0.5...107 m (1.64...351.05 ft)	2.5...107 m (8.2...351.05 ft)
White cardboard	90%	0.5...240 m (1.64...787.4 ft)	2.5...240 m (8.2...787.4 ft)
White plaster	100%	0.5...250 m (1.64...820.21 ft)	2.5...250 m (8.2...820.21 ft)
Reflective film	>300%	0.5...approx. 250 m (1.64... approx. 820.21 ft)	2.5...approx. 250 m (8.2... approx. 820.21 ft)

Tab. 6: Typical reflection values and scanning ranges

3.4.2 Beam diameter and distance between measured points

With increasing distance from the LD-LRS the laser beam on LD-LRS increases in size. As a result the diameter of the measured point on the surface of the object increases.

The distance-dependent diameter of the measured point is the distance (mm) × 2.8 mrad + 40 mm.

With increasing distance from the LD-LRS, the distance between the individual measured points also increases. The distance between the measured points is also dependent on the angular resolution configured. With a coarser resolution, the distance is larger, with a finer resolution the distance is smaller.

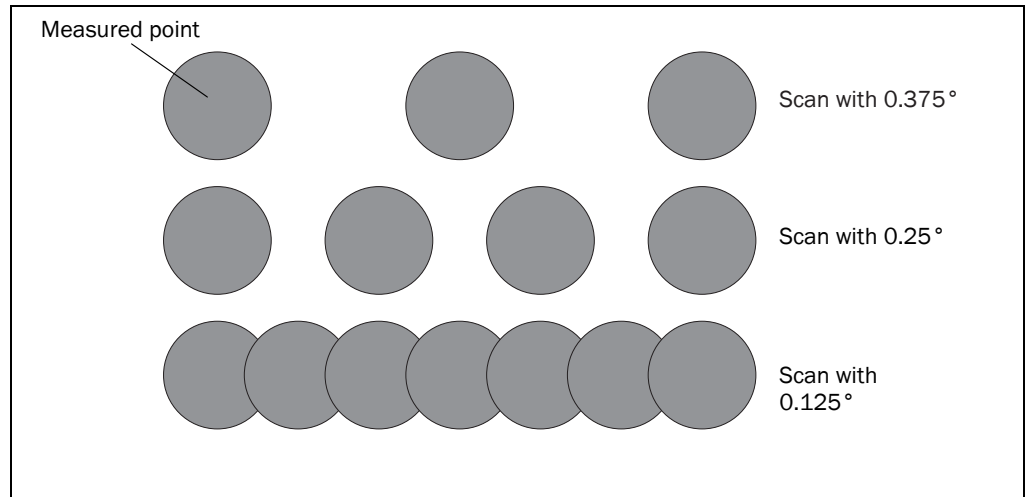

Fig. 11: Schematic layout of the distance between measured points at different angular resolutions

The two diagrams in Fig. 12 and Fig. 13 show the beam diameter and the distance between the measured points as a function of the distance from the LD-LRS.

Explanation The grey areas in the diagrams mark the area in which the distance between the measured points is larger than the beam diameter. In these areas there are therefore gaps between the points measured.

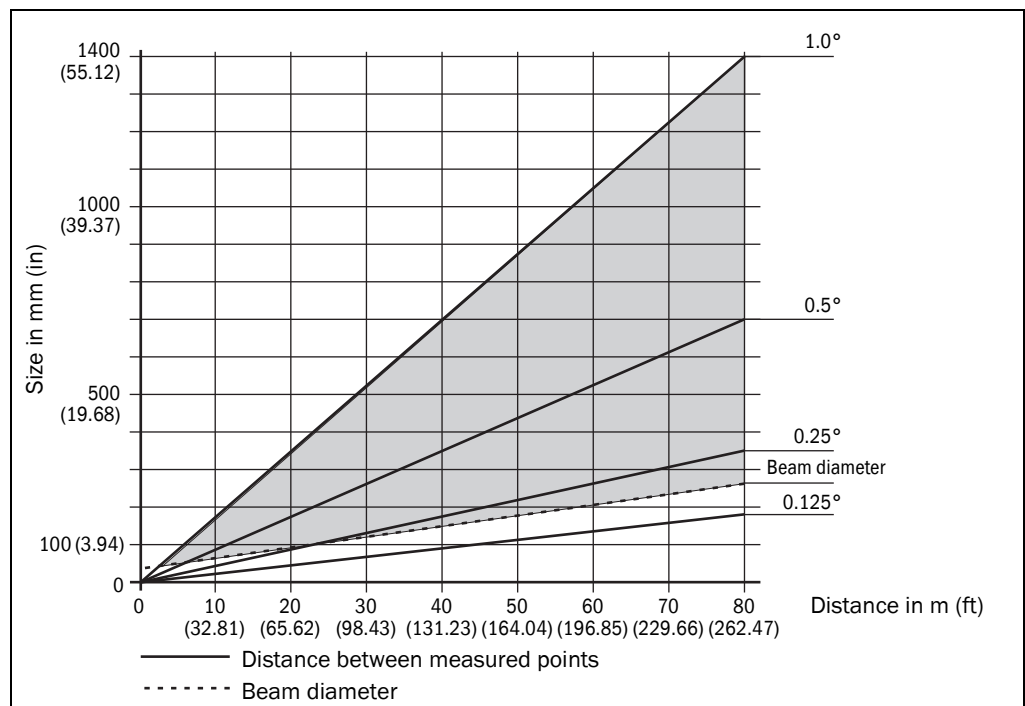

Fig. 12: Beam diameter and distance between measured points at 0 to 80 m (0 to 262.47 ft)

Example for angular resolution of 0.125° in Fig. 12

Distance 60 m (196.85 ft)

Distance intersection point 60 m (196.85 ft) gives a distance between the measured points of approx. **130 mm (7.87 in)**

Distance intersection point 60 m (196.85 ft) with the characteristic curve for beam diameter gives a beam size of approx. **200 mm (7.87 in)**

Result: no gaps during scanning

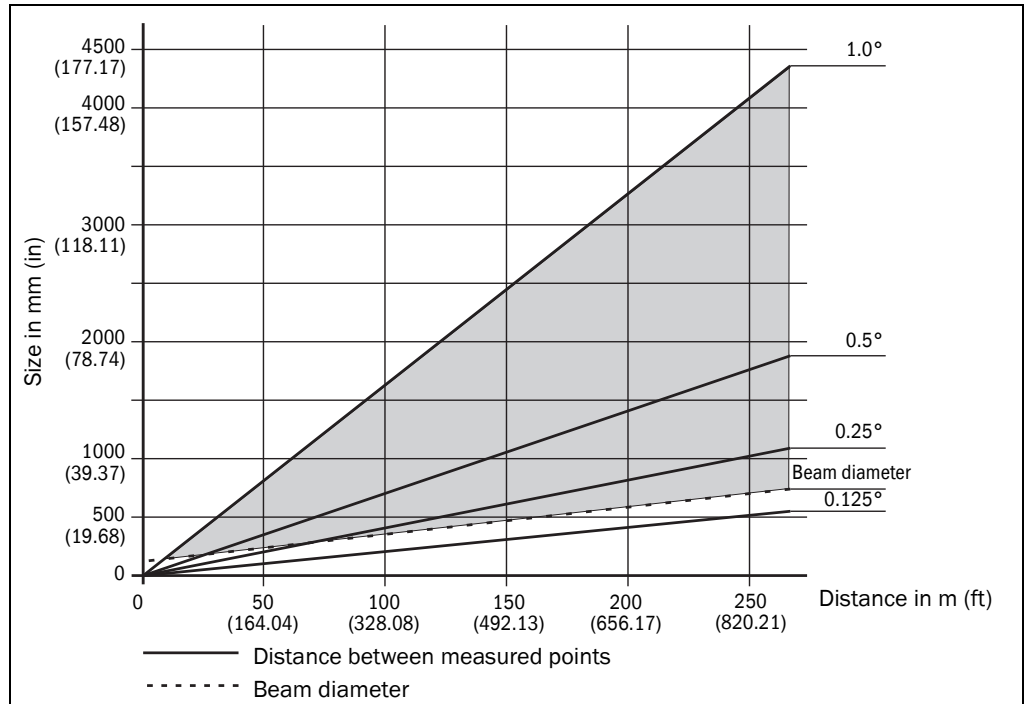

Fig. 13: Beam diameter and distance between measured points at 0 to 250 m (0 to 820.21 ft)

Example for angular resolution 0.5° in Fig. 13

Distance 150 m (492.13 ft)

Distance intersection point 150 m (492.13 ft) gives a distance between the measured points of approx. **1100 mm (43.31 in)**

Distance intersection point 150 m (492.13 ft) with the characteristic curve for beam diameter gives a beam size of approx. **450 mm (17.72 in)**

Result: gaps of approx. 650 mm during scanning (25.59 in)

Minimum object size: >650 mm (>25.59 in)

3.4.3 Minimum object size

For it to be possible to reliably detect an object, a beam must be fully incident on it once. If the beam is partially incident, less energy will be reflected by an object than necessary in some circumstances (see [Fig. 10 on page 21](#)).

It will be certain the beam is fully incident on the object if the object is at least as large as the distance between the measured points plus the beam diameter.

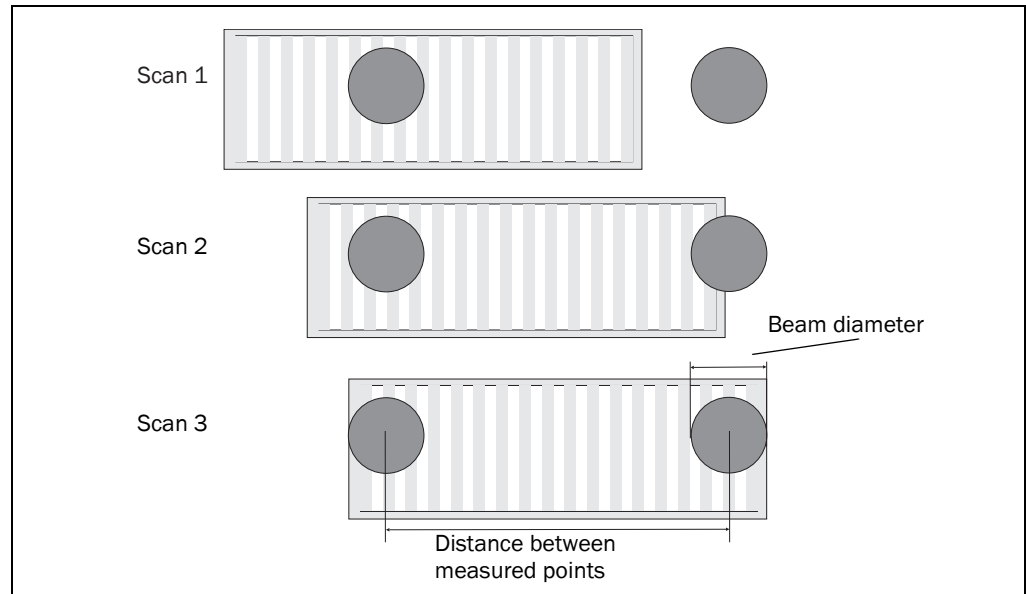

Fig. 14: Minimum object size for detection

Important In the example in [Fig. 14](#), the beam is fully incident on a moving object at least once during each scan. It will therefore be reliably detected if it has the necessary remission.

If an object is only as large as the beam diameter, then it will be detected if the laser is fully incident on it and it has the necessary remission.

How to calculate the minimum object size:

Beam diameter + distance between the measured points = minimum object size

➤ For the beam diameter and distance between the measured points as a function of the distance from the LD-LRS, see the diagrams in [Fig. 12](#) and [Fig. 13](#).

- Important**
- In particular on the usage of the LD-LRS for measured value output, it is necessary for a reliable measurement that the beam is incident on the object several times.
 - On the usage of the LD-LRS field application, as a rule the beam must be incident on an object several times in succession for the object to be detected as an infringement of the field.

3.4.4 Maximum and mean pulse frequency

On the LD-LRS the scanner head rotates at a selectable frequency from 5 to 10 Hz. During this process, a laser pulse is emitted after each angular step of e.g. 0.25° (adjustable).

The faster the scanner head rotates, the faster the measured value output and the finer the angular resolution is configured, the more exactly the contour will be determined.

Important In this case the interface selected on the LD-LRS and the downstream host must be able to transmit and process the volume of data.

NOTICE

During each laser pulse, the laser diode heats up. Like all semiconductors, a laser diode will also be irreparably damaged by excessively high temperatures. For this reason the pulse frequency is limited.

The maximum pulse frequency for the laser diode must never exceed 14.4 kHz. The maximum pulse frequency is given by the number of head revolutions per second and the angular resolution.

The mean pulse frequency must not exceed 10.8 kHz. The mean pulse frequency is given by the maximum pulse frequency and the size of the area scanned.

- For a scan area of 360° the mean pulse frequency is equal to the maximum pulse frequency.
- For a scan area of <360° the mean pulse frequency is lower than the maximum pulse frequency.

Examples for the maximum and mean pulse frequency

	Scanning area	Head revolutions	Angular resolution	Maximum pulse frequency	Mean pulse frequency
Example 1	270°	10 Hz	$1/4^\circ = 0.25^\circ$	14.4 kHz	10.8 kHz
Example 2	270°	5 Hz	$1/8^\circ = 0.125^\circ$	14.4 kHz	10.8 kHz
Example 4	360°	5 Hz	$1/4^\circ = 0.25^\circ$	7.20 kHz	7.20 kHz
Example 5	360°	10 Hz	$1/2^\circ = 0.5^\circ$	7.20 kHz	7.20 kHz

Tab. 7: Typical settings for the LD-LRS

Calculation example 1

Scan area: 270°

Head revolutions: 10 Hz

Angular resolution: $1/4^\circ = 0.25^\circ$

Max. pulse frequency: $10 \text{ Hz} \times 360 \times 4 = 14.4 \text{ kHz}$

Mean pulse frequency: $14.4 \text{ kHz} \times 270/360 = 10.8 \text{ kHz}$

Calculation example 2

Scan area: 270°

Head revolutions: 5 Hz

Angular resolution: $1/8^\circ = 0.125^\circ$

Max. pulse frequency: $5 \text{ Hz} \times 360 \times 8 = 14.4 \text{ kHz}$

Mean pulse frequency: $14.4 \text{ kHz} \times 270/360 = 10.8 \text{ kHz}$

Calculation example 3

Scan area: 360°

Head revolutions: 5 Hz

Angular resolution: $1/4^\circ = 0.25^\circ$

Max. pulse frequency: $5 \text{ Hz} \times 360 \times 4 = 7.20 \text{ kHz}$

Mean pulse frequency: $7.20 \text{ kHz} \times 360/360 = 7.20 \text{ kHz}$

Calculation example 4

Scan area: 360°

Head revolutions: 10 Hz

Angular resolutions: $1/2^\circ = 0.5^\circ$

Max. pulse frequency: $10 \text{ Hz} \times 360 \times 2 = 7.20 \text{ kHz}$

Mean pulse frequency: $7.20 \text{ kHz} \times 360/360 = 7.20 \text{ kHz}$

3.5 Applications

- individual products: measurement of the shape, position and volume of objects
- bulk products: volume and contour determination, determination of angle of surface
- crane control: profile measurement, collision protection, detection of position and position guiding
- metal processing: position and size of ingots, filling of hopper rollers
- measurement: floor plan surveying, longitudinal and transverse cross-sections in buildings
- sewer register: cross-section measurement of sluices and ducts
- transport systems: navigation, detection of surroundings, docking control
- mining: tunnel and cavern surveying, excavation surveying
- buildings: building surveillance, access monitoring, protection of facades and areas

3.6 Measured value output (raw data)

The LD-LRS outputs the following measured values on its interfaces:

- profile of the field of view in two-dimensional polar co-ordinates, as hex values
- contents of one revolution (360 ×): incl. number of the profile emitted, profile counter, sector numbers, step width, number of points per sector, time stamp for start/end of each sector, direction at the start/end of each sector, value and direction of the distances measured, status

The measured values can be transmitted to a computer system connected and evaluated there (see [section 3.9.1 “Data communication using messages” on page 30](#)).

- Important**
- It is only possible to output all measured values of a scan in real-time using the Ethernet interface.
 - If only the distances for the individual measured values are to be output, the CAN interface is also suitable for this task.
 - The data transmission rate of the RS-232 and RS-422 interfaces is limited to 115 KB, the data are transmitted in ASCII format. As a result, these interfaces are not suitable for the transmission of the measured values in real time.

3.6.1 Near range suppression

The near range suppression is used to suppress interference that could occur, e.g., on the usage of housing windows or due to the contamination of the optics.

If near range suppression is activated, measurements are only made from 2.5 m (8.2 ft), in the near range the measurement system is disabled.

- On the LD-LRSx100 the near range suppression is activated in the default delivery status. You should not deactivate this feature.
- On the LD-LRS1000 the near range suppression is inactive in the default delivery status. If you install a LD-LRS1000 in a housing (e.g. for explosion protection), then you must configure the near range filter in SOPAS ET.

Important

If you use the field application, then with near range suppression active you should not configure any fields that are closer than 2.5 m (8.2 ft) to the LD-LRS.



Using messages you can enable and disable the near range suppression on the LD-LRS for individually configured sectors, if e.g. a reference measurement is to be performed in the near range (see message listing "TLLDOEMLRSen" on the CD-ROM supplied).

3.7 Field application

With the aid of the integrated field application, the LD-LRS evaluates up to four evaluation fields within its scan area. Using the field application, you can e.g. implement systems for collision protection, for building surveillance or for access monitoring.

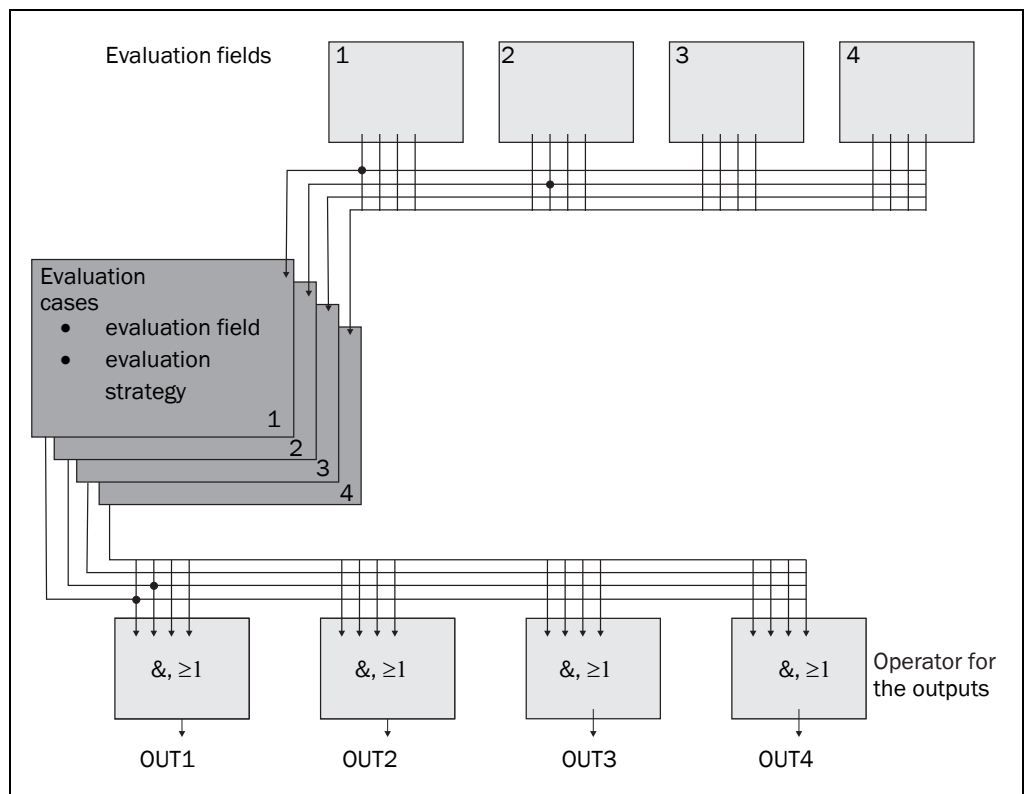

Fig. 15: Principle of the field application

The LD-LRS is adapted to the evaluation situation with the aid of up to ten evaluation cases. In the evaluation case, one of four configurable evaluation fields, an evaluation strategy and an output are selected. An operator is selected for each output; this operator determines the result on the output if more than one evaluation case acts on the output.

In the example in [Fig. 15](#), in evaluation case 1 evaluation field 1 is used, in evaluation case 2 evaluation field 2 is used. Both evaluation cases act on the output OUT1. If an AND operator is used for the results of the evaluation cases, then the output will only switch once both evaluation fields are infringed.

Enabling and disabling the field application



The field application is inactive in the default delivery status. You can activate the field application in SOPAS ET: LD_XXXX_APO1, APPLICATION, APPLICATION SELECTION, area APPLICATION SELECTION.

After switching on or off, the device is removed from the SOPAS ET project tree. You can add the LD-LRS back to the project tree by using scan and add (see [section 6.3.5 “Performing scan for devices in SOPAS ET” on page 60](#)).

3.7.1 Evaluation cases

An evaluation case defines which output field is evaluated in which way and on which output it acts. You can configure up to ten evaluation cases, all configured evaluation cases are active simultaneously.

For each evaluation case you configure in SOPAS ET:

- the evaluation strategy
- the evaluation field
- the output on which the evaluation case acts
- the response time of the output

Evaluation strategy

In SOPAS ET choose one of three possible evaluation strategies:

- field monitoring with blanking
The entire area of the field is monitored. If an object enters the field, this result is sent to the related output.
Using blanking, objects up to a certain size can be blanked, i.e. if such an object enters the evaluation field, it will not be detected as a field infringement.
- contour monitoring with blanking
The contour or parts of the contour in a field are monitored. As a result the LD-LRS can detect, e.g., that a door is opening outwards or that the position of the LD-LRS is being changed. Also crawling beneath a vertical evaluation field or the deflection of the laser beam by a mirror can be detected.
Using blanking the lack of part of a contour can be blanked up to a certain size.
- system test
The status of the LD-LRS is output on the configured output.

Evaluation field

Choose one of the evaluation fields already configured for the evaluation case. The shape of this field must match the evaluation strategy (see [section 3.7.2 “Evaluation fields” on page 29](#)).

Output

Choose one of the outputs for the evaluation case. If several monitoring cases act on an output, you must define how the results from the monitoring cases are linked logically (see [section 3.7.3 “Outputs” on page 30](#)).

Response time of the output

A response time of 1000 ms is defined for the outputs from the factory. You change this parameter in SOPAS ET. The response time for the output means that objects in the evaluation field or the lack of objects in the contour of the evaluation field will not immediately result in the response of the output. Objects must therefore be scanned several times if a response time is configured (for a scanning frequency of 10 Hz and a response time of 1000 ms for example 10 times).

Important The response time has an effect of the response time of the LD-LRS (see [section 9.2 “Response times” on page 72](#)).

3.7.2 Evaluation fields

With the aid of the integrated field application, up to four evaluation fields can be configured. The size and shape of these four evaluation fields can be configured almost entirely as required.

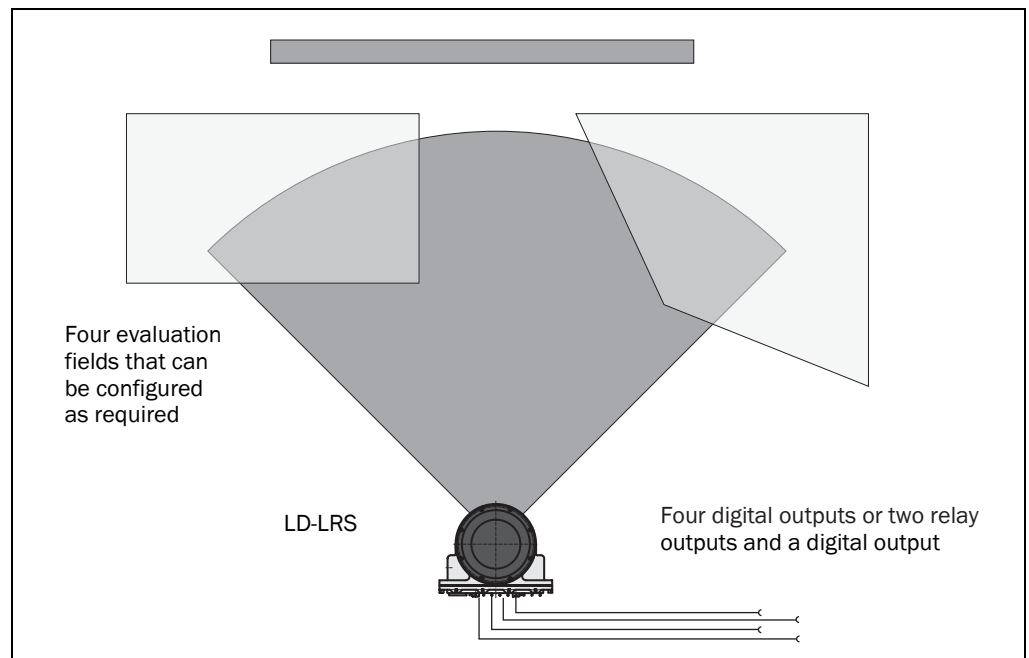

Fig. 16: Examples of different shapes for the evaluation field

The evaluation fields can be defined to suit the needs of your application. Evaluation fields can have the following shapes:

- rectangular
- polygon
- reach all the way to the LD-LRS
- be physically remote from the LD-LRS

You can configure the evaluation fields in SOPAS ET and transfer them to the LD-LRS. If the area to be monitored changes, then you can re-configure the LD-LRS via software without additional mounting effort.

3.7.3 Outputs

If several monitoring cases act on an output, you must define how the results of the monitoring cases are linked. The related results can be linked using an AND or an OR operator.

The outputs are configured as active high in the pre-setting. You can configure the outputs individually as active low.

The related output is reset immediately by the pre-setting. You can configure a delay of up to 10 s (e.g. to activate a horn or to send the output signal to a PLC).

3.8 Custom application

Custom applications can also be programmed for the LD-LRS and loaded into the flash memory on the laser measurement system instead of the field application.

To be able to program your own application, you will need:

- skills in a programming language, e.g. C
- a development environment with an editor and related compiler, an emulator and a special device

You should also participate in a training course on programming the LD-LRS at SICK AG. You can obtain further information from your SICK AG subsidiary.

NOTICE

A custom application will overwrite the field application!

If a custom application is loaded into the laser measurement system's flash memory, the integrated field application will be overwritten in the process. To load the field application back into the device, please consult your SICK support.

3.9 Data interfaces

The LD-LRS has different interfaces for the configuration and the transmission of measured values.

- Important**
- It is only possible to output all measured values of a scan in real-time using the Ethernet interface.
 - If only the distances for the individual measured values are to be output, the CAN interface is also suitable for this task.
 - The data transmission rate of the RS-232 and RS-422 interfaces is limited to 115 KB, the data are transmitted in ASCII format. As a result these interfaces are not suitable for transmitting the measured values in real time.

3.9.1 Data communication using messages

The LD-LRS continuously outputs, on request, the raw data for the profiles measured in two-dimensional polar co-ordinates as hex values. The structure of the data is described in [section 10.2 "Data communication via the data interfaces" on page 78](#).



The contents of the individual messages is described in the message listing "TLLDOEMLRSen" on the CD-ROM supplied.

3.9.2 Ethernet interface

The Ethernet interface has a data transmission rate of 10 MBaud (10BaseT). The interface is a TCP/IP peer to peer interface. Only half duplex is supported. Please ensure that the interface of your application is set to half duplex.

The factory setting for the Ethernet interface is as follows:

- IP address: 192.168.1.10
- subnet mask: 255.255.255.0
- TCP/IP port for SOPAS ET: 2111
- TCP/IP port for data messages: 49152



If necessary, adjust the TCP/IP configuration for the Ethernet interface to enable a connected PC (client) to communicate with the LD-LRS via Ethernet: PROJECT TREE, LD_XXXX_APO1, INTERFACES, ETHERNET, area ETHERNET

Important

To make the changes to the interface parameters effective, the LD-LRS must be reset after configuration (see [2.4 “Quick stop and Quick restart” on page 14](#)).

You will find a description of the electrical interface in section [5.2 “Connections of the LD-LRS” on page 44](#).

3.9.3 CAN

Important

The LD-LRS supports the CAN standard 2.0A.

The CAN interface supports data transmissions between 10 Bit/s and 1 Mbit/s. The maximum cable length is 30 m (98.43 ft).

For data communication via CAN you must configure the LD-LRS so that it can communicate with the host:



PROJECT TREE, LD_XXXX_APO1, INTERFACES, CAN, area CAN

The following interface parameters can be configured

- baud rate of the CAN bus
- ID of the scanner on the CAN
- the IDs of the devices from which the LD-LRS accepts messages

3.9.4 RS-232 interface

The RS-232 interface is available on the LD-LRS1000, LD-LRS2100 and LD-LRS4100 variants. On the LD-LRS1000 use DIP switch 1 (see [Fig. 26 on page 44](#)) to decide whether you want to use the RS-232 interface or the RS-422 interface. The RS-232 interface allows the configuration of the LD-LRS as well as the output of measured values.

The following interface parameters are defined and cannot be changed:

- number of data bits: 8
- number of stop bits: none
- number of parity bits: 1



The baud rate can be configured. PROJECT TREE, LD_XXXX_APO1, INTERFACES, SERIAL, area SERIAL HOST

You will find a description of the electrical interface in section [5.2 “Connections of the LD-LRS” on page 44](#).

3.9.5 RS-422

The RS-422 interface is available on the LD-LRS1000, LD-LRS3100 and LD-LRS5100 variants. On the LD-LRS1000 use DIP switch 1 (see [Fig. 26 on page 44](#)) to decide whether you want to use the RS-232 interface or the RS-422 interface.

The RS-422 interface allows the configuration of the LD-LRS as well as the output of measured values. The following interface parameters are defined and cannot be changed:

- number of data bits: 8
- number of stop bits: none
- number of parity bits: 1



The baud rate can be configured. PROJECT TREE, LD_XXXX_APO1, INTERFACES, SERIAL, area SERIAL HOST

You will find a description of the electrical interface in section [5.2 “Connections of the LD-LRS” on page 44](#).

3.10 Switching outputs

The LD-LRS has different switching outputs depending on the variant. These switching outputs can be allocated to the individual evaluation fields in the “Field evaluation” application. The switching outputs switch, for instance, if the allocated evaluation field is interrupted.

In a custom application, the switching outputs can also be assigned functions.

3.10.1 Digital outputs

LD-LRS1000, LD-LRS2100 and LD-LRS3100 have four digital outputs; LD-LRS4100 and LD-LRS5100 have one digital output.

In the inactive state, the outputs are at the supply voltage applied from the exterior as a quiescent potential (high) and switch to signal ground (low) when activated.

Note The maximum load on the 4 switching outputs is a total of 1 A.

Wired outputs	Max. current on all outputs	Max. current on each output
4	1 A	0.25 A
3	1 A	0.33 A
2	1 A	0.5 A
1	0.5 A	0.5 A

Tab. 8: Maximum output current on the switching outputs

Characteristic data	Properties
Switching behaviour	High side output High: quiescent potential Low: switching to signal ground
Properties	<ul style="list-style-type: none"> • not short-circuit protected • not electrically isolated from supply voltage
Electrical values	Quiescent potential 24 V DC, max. I_a , see Tab. 8

Tab. 9: Characteristic data for the switching outputs

The connection layout for the digital outputs is shown in [section “Wiring digital outputs” on page 52](#).

3.10.2 Relay outputs

LD-LRS4100 and LD-LRS5100 have two volt-free relay outputs. It is possible to connect to these relays, for example, 12 V systems for building surveillance.

Characteristic data	Properties
Switching current	0.5 A DC or AC ¹⁾
Switching voltage	Maximum 25 V AC or 60 V DC ²⁾

Tab. 10: Characteristic data for the relay outputs

- 1) No current peaks (current rush) above 0.5 A are allowed.
- 2) Safety extra-low voltage EN 50178

The connection layout for the relay outputs is shown in [section "Wiring relay outputs" on page 52](#).

3.11 Controls and status indicators

3.11.1 User interface

The laser measurement system operates fully automatically in normal operation without the intervention of an operator.

The interactive configuration is carried out using the provided SOPAS ET configuration software. The software used for this purpose runs on a PC that is connected to the LD-LRS via one of the interfaces.

Use the graphic scan view in SOPAS ET to verify the generated measured values and to verify the measurement area online. During this process, note that the monitor cannot display the data in real-time and therefore does not display all measured values.

Operating modes

Using SOPAS ET or using messages the LD-LRS can be switched to different operating modes:

- IDLE mode: stand by (scanner head at rest, laser off)
protects the laser diode and saves energy
- ROTATE mode: rotation (scanner head rotates, laser off)
protects the laser diode, the LD-LRS can switch quickly to the measure mode, particularly useful in cold weather
- MEASURE mode: measurement mode
- ERROR mode: for error polling via SOPAS ET or messages

3.11.2 Status indicators

The LD-LRS1000 has four LEDs. These visually signal the actual operational status and the status of the continuous self-check. The LEDs are on the front of the device on the LD-LRS1000. [Tab. 11](#) shows the function of the LEDs.

The two yellow LEDs can be operated as required in a custom programmed evaluation and are not coupled to the four digital outputs OUT1 to OUT4.

Yellow LED (1)	Yellow LED (2)	Green LED	Red LED	Meaning
Off	Off	Off	Off	Device switched off. No supply voltage.
On	On	On	On	LED test for 1 s after switching on. All switching outputs are active.
Off	Off	Flashing	Off	The device is operational. All switching outputs are inactive. In the measure mode the LED flashes quickly.
On	Off	Off	On	Evaluation field 1 has been infringed
Off	On	Off	On	Evaluation field 2 has been infringed
On	On	Off	On	Evaluation fields 1 and 2 have been infringed
Off	Off	Off	On	System error in the device. For information on troubleshooting see chapter 8 "Troubleshooting" on page 67 .

Tab. 11: Significance of the LEDs

3.12 Planning

3.12.1 System requirements of the LD-LRS

For commissioning and operating the LD-LRS, the following are required at the user:

- supply voltage 24 V DC $\pm 15\%$, generated as per IEC 364-4-41 (VDE 0100, part 410), output power minimum 40 W (see also [section 5.3.1 "Supply voltage" on page 49](#))
- for the heating (LD-LRSx100 only): supply voltage 24 V DC (maximum 6 V residual ripple), power consumption maximum 6 A/144 W (cyclic)
- standard Intel Pentium PC or compatible, at least Pentium III, 500 MHz; RAM: minimum 256 MB, 512 MB recommended; operating system: MS Windows 2000, XP or VISTA; monitor: minimum 256 colours, 65536 colours recommended; hard disc: minimum 170 MB free memory; CD-ROM drive; HTML browser on PC, e.g. Internet Explorer™: for the online help system for SOPAS ET; Data interface RS-232, RS-422, Ethernet or CAN (see also [section 5.3.3 "General conditions for the data interface" on page 50](#)). If necessary RS-232/RS-422 converter, if PC interface and interface on the LD-LRS do not match

3.12.2 Mounting requirements

The LD-LRS must be mounted as follows:

- robust
- without vibration
- without oscillations

Mounting kits

The following mounting kits are available (see [section 10.3.2 “Available accessories” on page 90](#)):

LD-LRS1000:

- mounting kit part no. 5311055 with mounting material

LD-LRSx100:

- mounting kit part no. 2018303 with mounting material
- mast bracket part no. 2018304 with mounting material

As an alternative you can use a strong stable mounting bracket that provides adjustable alignment of the LD-LRS in the X and Y axis. The LD-LRS1000 weighs approx. 4.1 kg (9.04 lb), the LD-LRSx100 9.1 kg (20.06 lb).

NOTICE

Mount the LD-LRSx100 such that it is not exposed to direct sunlight (if necessary fit canopy). In this way an inadmissible increase in the temperature inside the system is avoided.

3.12.3 Distance between LD-LRS and the object/surface to be monitored

The measurement area on the LD-LRS starts at 0.5 or 2.5 m (1.64 or 8.2 ft) in front of the optics (light output window).

To prevent false alarms, in the case of the recessed installation of the LD-LRS on a ledge or in a niche the increase in the size of the laser beam with increasing distance along the wall is to be taken into account. If mounted incorrectly, depending on the distance and position of the fields defined in the LD-LRS, the wall (or an object fastened to it) may be continuously detected in the scan area, as the laser beam is incident on it.

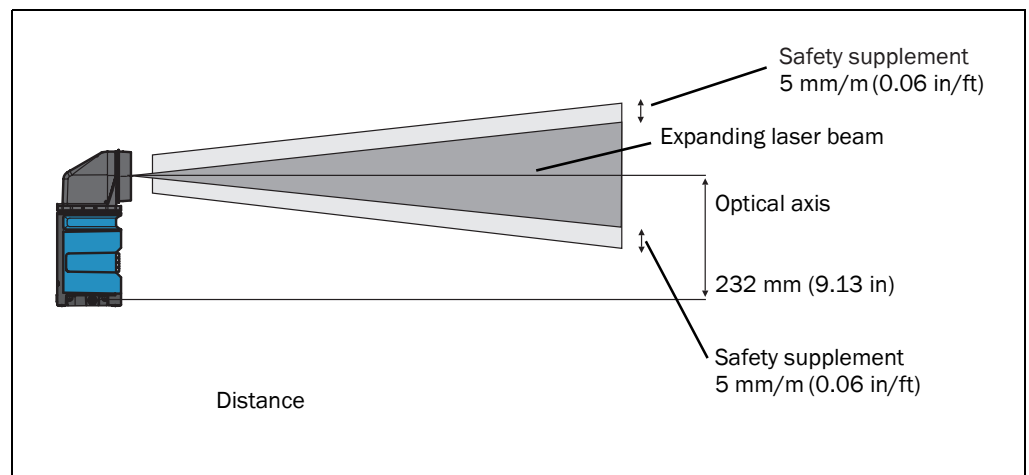

Fig. 17: Increase in the size of the beam and safety supplement

The optical axis is used as the reference plane for the distance to be maintained from the wall; on the vertically mounted LD-LRS this axis is approx. 232 mm (9.13 in) above the bottom edge of the housing.

The distance-dependent increase in the size of the beam can be calculated using the formula:

$$\text{beam diameter} = (\text{distance (mm)} \times 2.8 \text{ mrad}) + 40 \text{ mm}^{1)}$$

The following table shows a few values as examples:

Distance	5 m (16.4 ft)	10 m (32.81 ft)	15 m (49.21 ft)	20 m (65.62 ft)	25 m (82.02 ft)	30 m (98.43 ft)
Beam diameter	54 mm (2.13 in)	68 mm (2.68 in)	82 mm (3.23 in)	96 mm (3.78 in)	110 mm (4.33 in)	124 mm (4.88 in)

Tab. 12: Beam diameter at different distances from the laser measurement system

For the assessment of whether the laser beam can be incident on an object or the wall, the distance of half the beam diameter from the optical axis is used.

Recommendation Take into account safety supplement of approx. 5 mm per meter (0.06 in/ft).

Example

Recessed installation of the LD-LRS with a monitoring radius of 15 m (49.21 ft).

Beam diameter in 15 m (49.21 ft) distance = (15000 mm × 2.8 mrad) + 40 mm = 82 mm.

Safety distance = 5 mm/m × 15 m = 75 mm (0.06 in/ft × 49.21 ft = 2.95 in).

$$\begin{aligned} \text{Distance to the optical axis} &= \text{beam diameter}/2 + \text{safety distance} \\ &= 82 \text{ mm}/2 + 75 \text{ mm} \text{ (3.23 in}/2 + 2.95 \text{ in)} \\ &= 116 \text{ mm} \text{ (4.57 in)} \end{aligned}$$

Result:

At a distance of 15 m (49.21 ft) there is a clearance between the bottom edge of the device and the edge of the increased size laser beam of approx. 116 mm (232 mm - 116 mm = 116 mm) (9.1338 in - 4.5669 in = 4.5669 in).

1) Due to the transmit lens.

4 Mounting

NOTICE

Do not open the housing for the LD-LRS. If the housing is opened, any warranty claims against SICK AG will be rendered void.

4.1 Overview of the mounting steps

- select mounting method for the LD-LRS
- mounting and adjusting the LD-LRS

4.2 Preparations for mounting

4.2.1 Components to be mounted

- a LD-LRS1000 (weight approx. 4.1 kg (9.04 lb))
or
- a LD-LRSx100 (weight approx. 9.1 kg (20.06 lb))

4.2.2 Material and accessories necessary

For the LD-LRS1000

- mounting kit part no. 5311055 with mounting material (not included with delivery, see [section 10.3.2 “Available accessories” on page 90](#))
or
- alternative on provision of a fixing bracket by the user:
 - stable mounting bracket that provides adjustable alignment of the LD-LRS1000 in the X and Y axis
 - 3 screws M6 for the LD-LRS1000, screw length dependent on the wall thickness of the fixing bracket used

For the LD-LRSx100

- mounting kit part no. 2018303 with mounting material (not included with delivery, see [section 10.3.2 “Available accessories” on page 90](#))
- mast bracket part no. 2018304 with mounting material (not included with delivery, see [section 10.3.2 “Available accessories” on page 90](#))
or
- alternative on provision of a fixing bracket by the user:
 - stable mounting bracket that provides adjustable alignment of the LD-LRSx100 in the X and Y axis
 - 4 screws M8 for the LD-LRSx100. Screw length dependent on the wall thickness of the fixing bracket used.

4.2.3 Necessary tools

- 2 screws M6 for mounting the SICK fixing bracket to the mounting surface. Screw length dependent on the thickness of the mounting surface.
- tool set

4.2.4 Select mounting location

Mount the LD-LRSx100 such that it is not exposed to direct sunlight (if necessary fit canopy). In this way an inadmissible increase in the temperature inside the system is avoided.

Avoid installing with view of glass or stainless steel surfaces.

4.3 Mounting and adjustment of the device

4.3.1 LD-LRS1000

NOTICE

Risk of damage to the device!

The maximum screw length in the M6 blind threaded hole is 12 mm (0.47 in). Longer screws will damage the device.

- Use screws of suitable length.

The LD-LRS1000 has three M6 blind thread holes and is fastened using 3 M6 screws (see [section 9.3.1 “Dimensional drawing LD-LRS1000” on page 73](#)).

For secure mounting at least 3 M6 screws with washers and locking washers are required. The supply of power must be switched off.

The LD-LRS1000 can be fitted in any position.

1. Prepare surface from mounting the fixing bracket for the LD-LRS as described in [section 4.2 “Preparations for mounting” on page 37](#).
2. Insert screws in the holes in the bracket and screw into the blind threaded hole in the LD-LRS. Only tighten screws lightly.
3. The scanner head on the LD-LRS must be free to rotate.
4. Align the LD-LRS.
5. Tighten screws.
6. Check the alignment

Mounting with bracket for the LD-LRS1000

The LD-LRS can be mounted with the aid of the SICK fixing bracket part no. 5311055. The slots on the fixing bracket permit rotation by $\pm 5^\circ$ for the fine alignment of the LD-LRS.



Fig. 18: Fixing bracket LD-LRS1000

The dimensions of the fixing bracket are shown in [Fig. 44 on page 75](#).

4.3.2 LD-LRSx100

The LD-LRSx100 is mounted using M8 blind threaded holes (see [section 9.3.2 “Dimensional drawing LD-LRS2100, 3100, 4100 and 5100” on page 74](#)).

For secure mounting at least 4 M8 screws with washers and locking washers are required. The supply of power must be switched off.

NOTICE

Risk of damage to the device!

The maximum screw length in the M8 blind threaded hole is 9 mm (0.35 in). Longer screws will damage the device.

- Use screws of suitable length.

Important To achieve better run-off of moisture (rain, fog, etc.) and/or to reduce the deposition of dust, mount the device orientated overhead (cover pointing down).

Requirements for enclosure rating IP 67

To retain the IP enclosure rating 67, the cover must not be removed. The connection plug must also be securely fastened to the rear and the unused PG cable entries in the plug must be fitted with the blanking covers.

Mounting with bracket for the LD-LRSx100

The LD-LRS can be mounted on flat surfaces with the aid of the SICK fixing bracket part no. 2018303. The slots on the fixing bracket permit rotation by $\pm 7.5^\circ$ for the fine alignment of the LD-LRS.



Fig. 19: Fixing bracket LD-LRSx100

The dimensions of the fixing bracket are shown in [Fig. 45 on page 76](#).

Mounting with mast bracket for the LD-LRSx100

The LD-LRS can be mounted on a mast with the aid of SICK fixing bracket part no. 2018304 and part no. 2018303.



Fig. 20: Mast bracket LD-LRSx100

The dimensions of the fixing bracket are shown in [Fig. 46 on page 77](#).

The LD-LRS is fastened to the mast with the aid of the steel clamping strip part no. 5306222 and the steel clamping strip lock part no. 5306221.

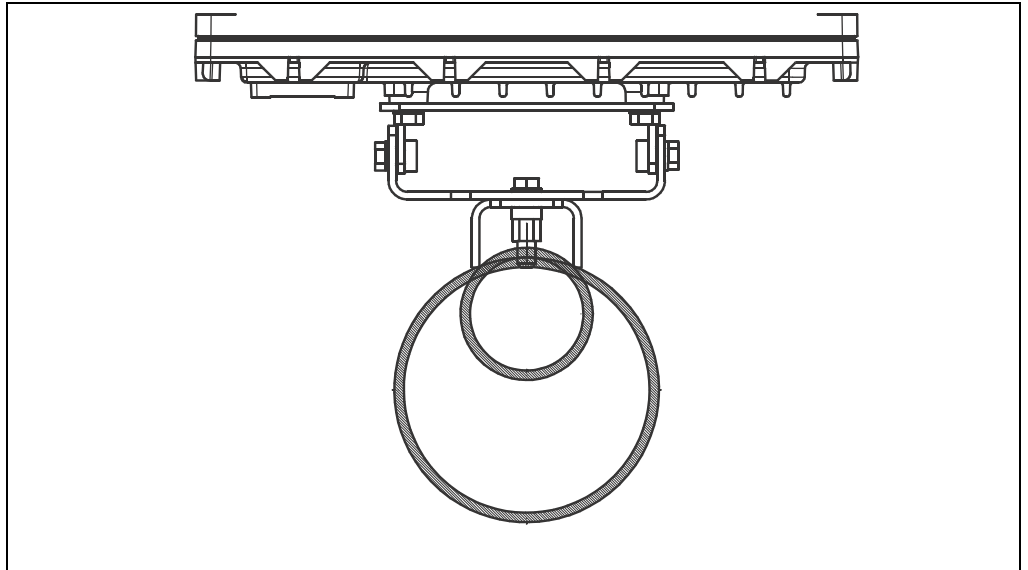

Fig. 21: Mounting the LD-LRSx100 on the mast

4.3.3 Mounting of several LD-LRS

If several LD-LRS are mounted, they are to be arranged or shielded such that the laser beam cannot be received by a different LD-LRS.

NOTICE

Risk of interference on the LD-LRS!

Sources with a wavelength of 905 nm may cause interference if they act directly on the LD-LRS.

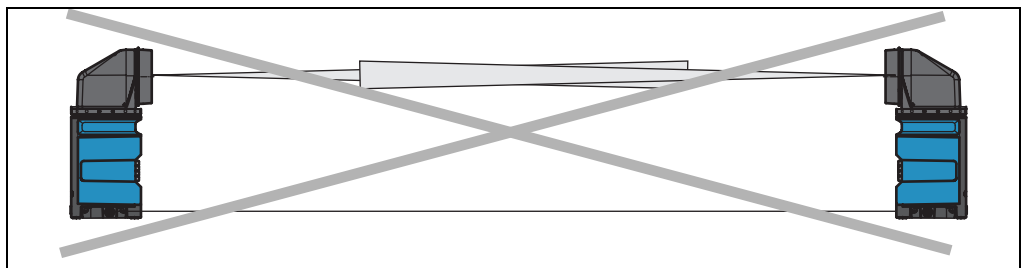

Fig. 22: Incorrect placement of two LD-LRS

Correct placement of several LD-LRS

Arrange or shield several LD-LRS such that the laser beam cannot be received by a different LD-LRS.

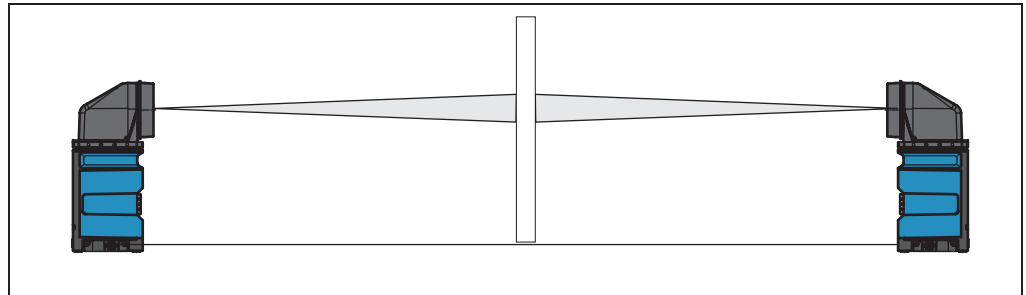

Fig. 23: Allowed placement of two LD-LRS with shielding

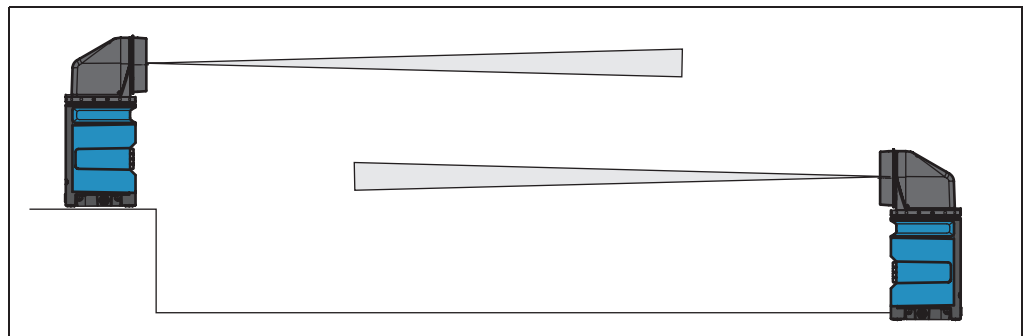

Fig. 24: Allowed placement of two LD-LRS with vertical offset

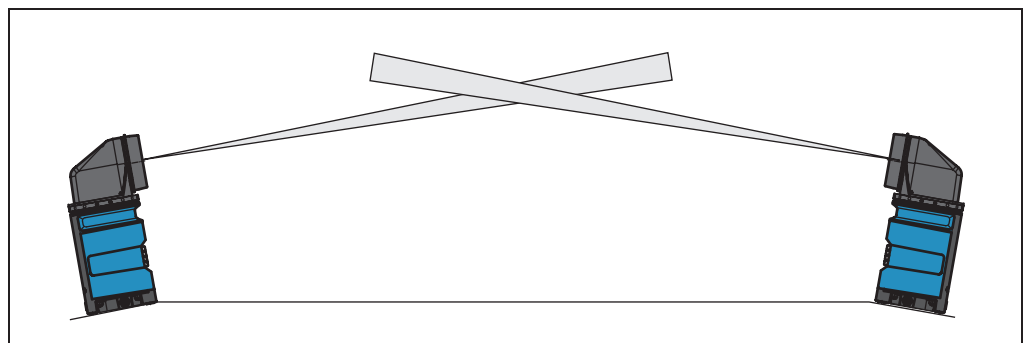

Fig. 25: Allowed placement of two LD-LRS with directional offset

4.4 Dismanteling the system

1. Switch off the supply voltage.
2. Remove the connection cables.
3. Undo screws for mounting the LD-LRS to the fixing and remove device.

Important On final decommissioning, please observe the disposal requirements in section [7.2](#) “Disposal” on page [64](#) for environmentally correct disposal.

5 Electrical installation

NOTICE

Only authorised personnel are allowed to perform the electrical installation work.

- Do not open the housing.
- Observe the current safety regulations when working on electrical systems.

Switch the entire machine/system offline!

The machine/system could inadvertently start up while you are connecting the device.

- Ensure that the entire machine/system is disconnected during the electrical installation.

5.1 Overview of the installation steps

- Connect supply voltage to the LD-LRS.
- Wire switching outputs (application-dependent).
- Temporarily connect PC (configuration).
- Wire data interface for operation.

5.2 Connections of the LD-LRS

5.2.1 Connections of the LD-LRS1000

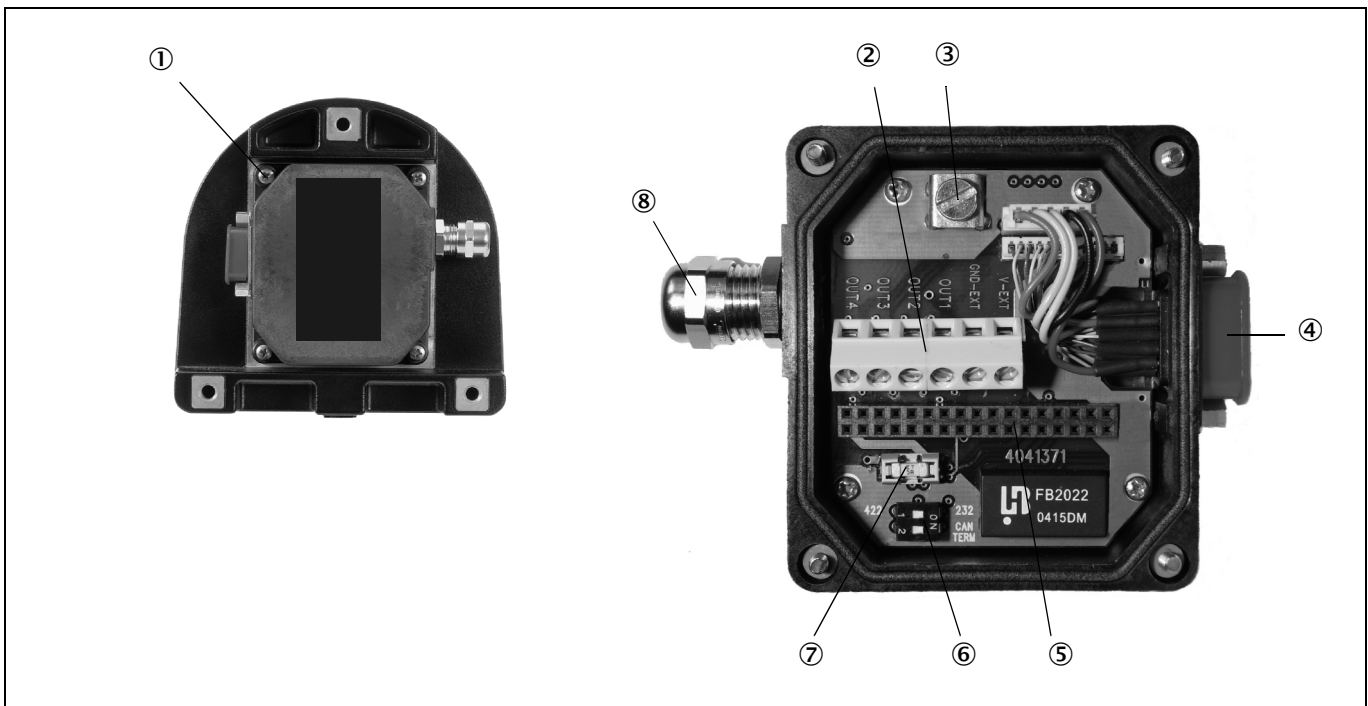

Fig. 26: LD-LRS1000: layout of the interface adapter

Elements of the interface adapter

1. fixing screw (4 ×)
2. 6-way terminal block
(supply voltage, switching outputs)
3. ground connection
4. 15 pin D-Sub HD plug
(data, outputs, supply voltage)
5. 34-way spring strip (connection to the LD-LRS)
6. DIP switch 1 (RS-232/RS-422)
DIP switch 2 (CAN bus termination)
7. fuse (supply voltage)
8. PG7 cable entry

Function of the DIP switches

DIP switch	Function	Default setting
1	RS-232/RS-422	RS-232
2	CAN bus termination	Termination ON ¹⁾

Tab. 13: Function of the DIP switches

- 1) If an external terminating resistor is used, you must deactivate the termination in the LD-LRS1000.

Assignment for the 6-way terminal block

Label on printed circuit board	Signal	Function
V-EXT	DC +24 V	Supply voltage
GND-EXT	GND	Sensor ground
OUT1	OUT1	Switching output 1, function depending on application
OUT2	OUT2	Switching output 2, function depending on application
OUT3	OUT3	Switching output 3, function depending on application
OUT4	OUT4	Switching output 4, function depending on application

Tab. 14: Assignment for the 6-way terminal block

15-pin D-Sub HD plug

Pin	Signal	Interface	Function
1	DC 24 V		Supply voltage
2	CAN L	CAN bus (IN/OUT)	CAN bus Low
3	CAN H	CAN bus (IN/OUT)	CAN bus High
4	GND_Data		Data interfaces ground
5	GND		Supply voltage ground
6	RD+	RS-422	Receiver+
7	RD-/RxD	RS-422/RS-232	Receiver-
8	TD+	RS-422	Sender+
9	TD-/TxD	RS-422/RS-232	Sender-
10	OUT1		Switching output 1, function depending on application
11	TPIP	Ethernet IN	Receiver+
12	TPIN	Ethernet IN	Receiver-
13	TPOP	Ethernet OUT	Sender+
14	TPON	Ethernet OUT	Sender-
15	OUT2		Switching output 2, function depending on application
Housing	-	-	Screen

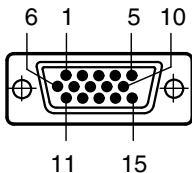

Tab. 15: Pin -assignment for the 15 pin D-Sub HD plug

5.2.2 Connections of the LD-LRSx100

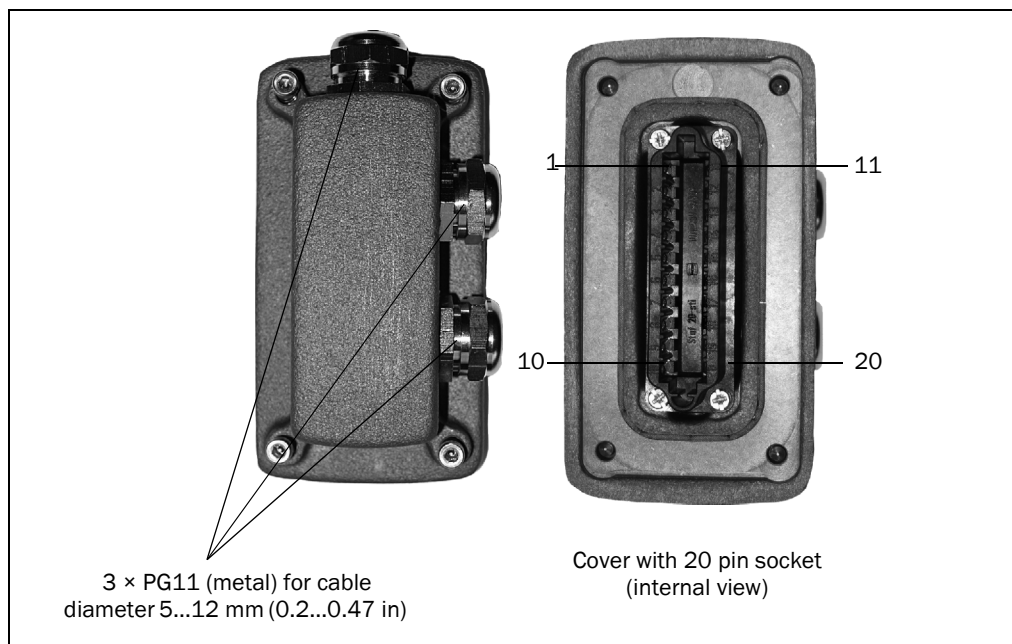

Fig. 27: Housing for the 20 pin connection with Harting socket

The cable(s) are laid through the PG cable entries. There are screw connections on the rear of the 20 pin socket insert for laying the wires.

5.2.3 Terminal block of the LD-LRS2100

Pin	Signal	Interface	Function
1	DC 24 V_HZG		Supply voltage for the heating
2	DC 24 V		Supply voltage for the electronics
3	OUT1	Switching output 1	Function depending on the application
4	OUT3	Switching output 3	Function depending on the application
5	-		Reserved
6	TxD	RS-232	Sender-
7	-		Reserved
8	CAN H	CAN-Bus (IN/OUT)	CAN-Bus High
9	TPOP	Ethernet OUT	Sender+
10	TPON	Ethernet OUT	Sender-
11	GND_HZG		Heating ground
12	GND		Electronics ground
13	OUT2	Switching output 2	Function depending on the application
14	OUT4	Switching output 4	Function depending on the application
15	GND_Data		Data interfaces ground
16	RxD	RS-232	Receiver-
17	-		Reserved
18	CAN L	CAN-Bus (IN/OUT)	CAN-Bus Low
19	TPIP	Ethernet IN	Receiver+
20	TPIN	Ethernet IN	Receiver-
Housing	-	-	Screen

Tab. 16: LD-LRS2100: assignment of the 20 pin Harting plugs

LD-LRS

5.2.4 Terminal block of the LD-LRS3100

Pin	Signal	Interface	Function
1	DC 24 V_HZG		Supply voltage for the heating
2	DC 24 V		Supply voltage for the electronics
3	OUT1	Switching output 1	Function depending on the application
4	OUT3	Switching output 3	Function depending on the application
5	-		Reserved
6	TD-	RS-422	Sender-
7	TD+	RS-422	Sender+
8	CAN H	CAN-Bus (IN/OUT)	CAN-Bus High
9	TPOP	Ethernet OUT	Sender+
10	TPON	Ethernet OUT	Sender-
11	GND_HZG		Heating ground
12	GND		Electronics ground
13	OUT2	Switching output 2	Function depending on the application
14	OUT4	Switching output 4	Function depending on the application
15	GND_Data		Data interfaces ground
16	RD-	RS-422	Receiver-
17	RD+	RS-422	Receiver+
18	CAN L	CAN-Bus (IN/OUT)	CAN-Bus Low
19	TPIP	Ethernet IN	Receiver+
20	TPIN	Ethernet IN	Receiver-
Housing	-	-	Screen

Tab. 17: LD-LRS3100: assignment of the 20 pin Harting plugs

5.2.5 Terminal block of the LD-LRS4100

Pin	Signal	Interface	Function
1	DC 24 V_HZG		Supply voltage for the heating
2	DC 24 V		Supply voltage for the electronics
3	REL1.1	Relay output 1.1	Normally open, function depending on application
4	REL2.1	Relay output 2.1	Normally open, function depending on application
5	OUT3	Switching output 3	Function depending on the application
6	TxD	RS-232	Sender-
7	-		Reserved
8	CAN H	CAN-Bus (IN/OUT)	CAN-Bus High
9	TPOP	Ethernet OUT	Sender+
10	TPON	Ethernet OUT	Sender-
11	GND_HZG		Heating ground
12	GND		Electronics ground
13	REL1.2	Relay output 1.2	Normally open, function depending on application
14	REL2.2	Relay output 2.2	Normally open, function depending on application
15	GND_Data		Data interfaces ground
16	RxD	RS-232	Receiver-
17	-		Reserved
18	CAN L	CAN-Bus (IN/OUT)	CAN-Bus Low
19	TPIP	Ethernet IN	Receiver+
20	TPIN	Ethernet IN	Receiver-
Housing	-	-	Screen

Tab. 18: LD-LRS4100: assignment of the 20 pin Harting plugs

5.2.6 Terminal block of the LD-LRS5100

Pin	Signal	Interface	Function
1	DC 24 V_HZG		Supply voltage for the heating
2	DC 24 V		Supply voltage for the electronics
3	REL1.1	Relay output 1.1	Normally open, function depending on application
4	REL2.1	Relay output 2.1	Normally open, function depending on application
5	OUT3	Switching output 3	Function depending on the application
6	TD-	RS-422	Sender-
7	TD+	RS-422	Sender+
8	CAN H	CAN-Bus (IN/OUT)	CAN-Bus High
9	TPOP	Ethernet OUT	Sender+
10	TPON	Ethernet OUT	Sender-
11	GND_HZG		Heating ground
12	GND		Electronics ground
13	REL1.2	Relay output 1.2	Normally open, function depending on application
14	REL2.2	Relay output 2.2	Normally open, function depending on application
15	GND_Data		Data interfaces ground
16	RD-	RS-422	Receiver-
17	RD+	RS-422	Receiver+
18	CAN L	CAN-Bus (IN/OUT)	CAN-Bus Low
19	TPIP	Ethernet IN	Receiver+
20	TPIN	Ethernet IN	Receiver-
Housing	-	-	Screen

Tab. 19: LD-LRS5100: assignment of the 20 pin Harting plugs

5.3 Preparing the electrical installation

5.3.1 Supply voltage

24 V DC ±15% as per IEC 364-4-41 (note the permissible cable lengths in [Tab. 20 on page 50](#)).

The LD-LRS draws the following power:

- on switching on without switching outputs wired typically 36 W
- in operation typically 12 W, plus a maximum of 12 W per switching output wired

The supply of power/the external power supply for the supply of power must be able to provide at least 40 W continuous power, if all switching outputs are wired at least 65 W continuous power.



WARNING

Use safety transformer

The output circuit must be safely electrically isolated from the input circuit, this feature is normally provided by a safety transformer in accordance with IEC 742 (VDE 0551).



Heating (only LD-LRSx100)

24 V DC (maximum 6 V residual ripple), power consumption maximum 6 A/144 W (cyclic)

5.3.2 Wire cross-sections

- Wire all connections with copper cables!
- Use the following wire cross-sections:
 - supply voltage at least 0.25 mm² (approx. 24 AWG), if local supply of power (power supply) in the immediate vicinity
 - supply voltage at least 1.0 mm² (approx. 18 AWG) at maximum length of 20 m (65.62 ft), if connection is made to an existing 24 V DC supply
 - switching outputs minimum 0.25 mm² (approx. 24 AWG), maximum cable length 50 m (164.04 ft) with 0.5 mm² (approx. 22 AWG)
 - data interface minimum 0.25 mm² (approx. 24 AWG)
 - For the LD-LRS1000 the outside diameter of the common cable must be a maximum of 5.6 mm (0.22 in) due to the PG7 cable entry.
- Lay all cables such that there is no risk of tripping and all cables are protected against damage.

On the usage of a typical power supply with a nominal voltage of 24 V DC ±5%, the following maximum cable lengths are allowed for the supply of the operating voltage:

Wire cross-section	Cable length
0.25 mm ² (0.01 in ² approx. 24 AWG)	5 m (16.4 ft)
0.5 mm ² (0.02 in ² approx. 22 AWG)	10 m (32.81 ft)
1.0 mm ² (0.04 in ² approx. 18 AWG)	20 m (65.62 ft)

Tab. 20: Maximum cable lengths for the supply voltage

5.3.3 General conditions for the data interface

The table below shows the recommended maximum length of cable as a function of the data transmission rate selected.

Interface type	Transmission rate	Maximum cable length
RS-232	115 200 Bd	10 m (32.81 ft)
RS-422	115 200 Bd	100 m (328.08 ft)
CAN bus ¹⁾	1 MBit/s	30 m (98.43 ft)

Tab. 21: Maximum cable lengths for the data interfaces

1) With appropriate cable termination, termination in accordance with related specification.

Important

- Use screened cable (twisted-pair) with at least 0.25 mm² (approx. 24 AWG).
- To prevent interference, do not lay data cable in parallel with power supply and motor cables over a long run, e.g. in cable ducts.

5.4 Undertaking electrical installation on the LD-LRS1000

5.4.1 Equipment

- tool set
- digital multimeter (current/voltage measurement)

NOTICE

Reduced enclosure rating!

- If the interface adapter is removed, the LD-LRS1000 is no longer compliant with enclosure rating IP 65. To prevent damage due to the entry of moisture and dirt, only open the adapter in dry, clean surroundings.
- If necessary, pre-wire and fit the adapter in suitable surroundings.

- Ensure the power supply to which the LD-LRS is connected is switched off.
- Remove interface adapter on the underside of the device. For this purpose undo the four fixing screws (Fig. 26 on page 44) and pull the adapter carefully off the device perpendicular to the base.

Connecting cable for supply voltage and switching outputs

The PG7 cable entry (metal) has an earth connection to the device. If a screened connecting cable is used, as necessary connect the screen braid on the cable to the cable entry.

- For this purpose, shorten the screen braid as appropriate before assembling the cable entry and fit over the plastic insert for the cable entry.
1. Undo fitting for the PG7 cable entry.
 2. Pull cable for supply voltage and switching outputs with maximum outside diameter \varnothing 5.6 mm (0.22 in) through plastic insert for the PG7 cable entry.
 3. Connect electrically isolated wires to the terminal block.
 4. If necessary, connect screen braid on the cable to the cable entry.
 5. Fit PG7 cable entry fitting and tighten.
 6. Carefully re-fit interface adapter to the LD-LRS such that the 15 pin D-Sub socket is over the related plug in the device.
 7. Press adapter gently.
 8. Tighten the four fixing screws for the adapter.

Connecting supply voltage

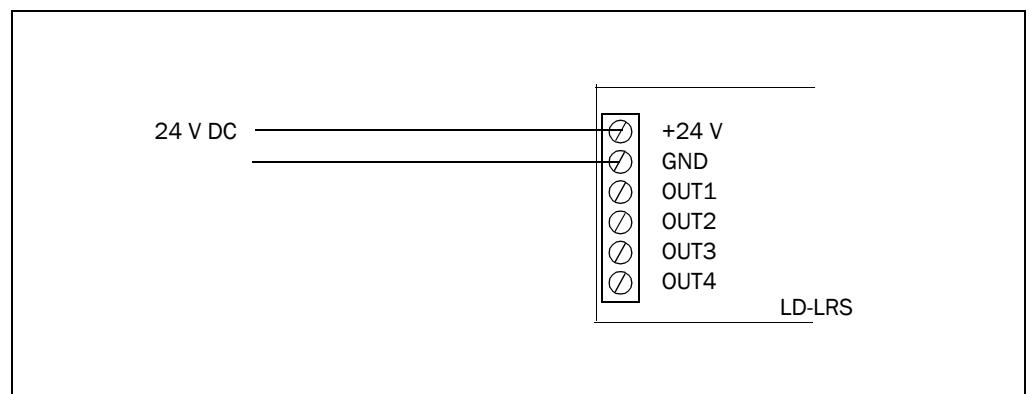

Fig. 28: Connecting supply voltage

Wiring digital outputs

NOTICE

The switching outputs are not short-circuit protected.

Fig. 29 on page 52 shows the wiring of the switching output OUT1. Section 3.10.1 “Digital outputs” on page 32 describes the characteristic data of the switching outputs.

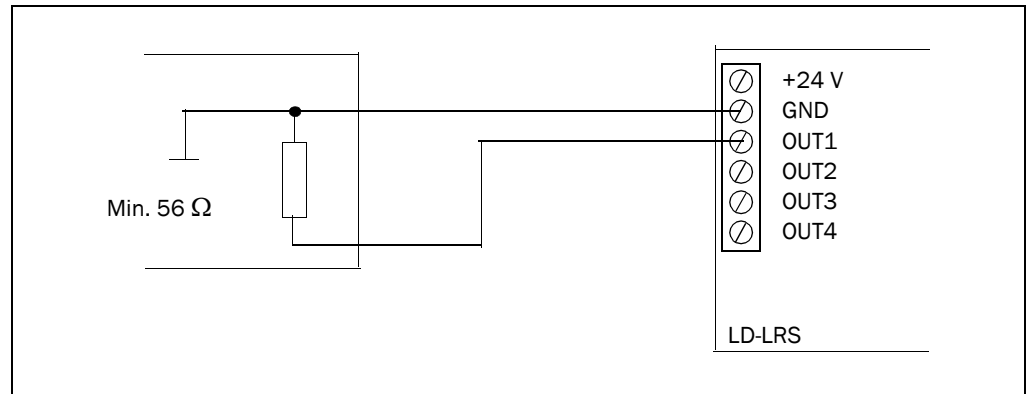

Fig. 29: Wiring switching outputs

- Recommendation** ➤ To check the switching functions using a high impedance digital voltmeter, wire the outputs to a load. In this way the indication of incorrect voltages/switch states will be avoided.

Wiring relay outputs

Fig. 30 shows an example of the wiring of a relay output. Section 3.10.2 “Relay outputs” on page 33 describes the characteristic data for the relay outputs.

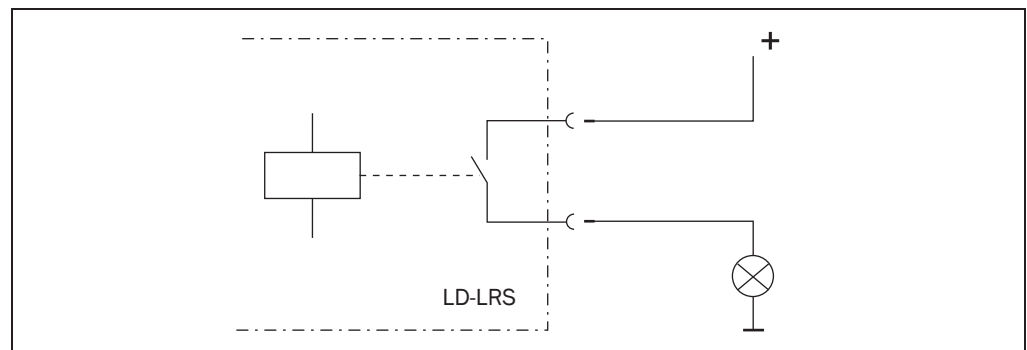

Fig. 30: Wiring relay outputs

Wiring CAN interface

To wire the CAN interface a screened “twisted-pair” cable is required. The 120 Ω terminator must be connected to pin 7 and pin 8.

- Pay attention to max. cable length as per [section 5.3.3 “General conditions for the data interface” on page 50.](#)

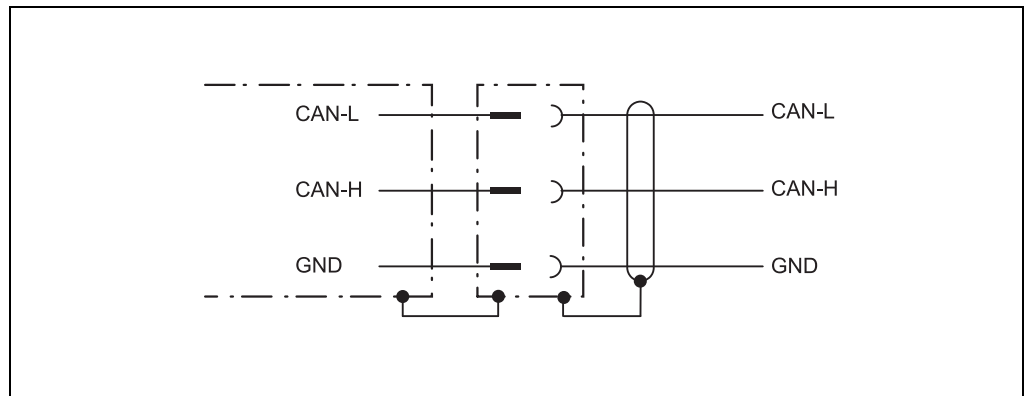

Fig. 31: Wiring of the CAN interface

Wiring the RS-232 interface

A screened cable is required for the wiring of the RS-232 interface.

- Pay attention to max. cable length as per [section 5.3.3 “General conditions for the data interface” on page 50.](#)

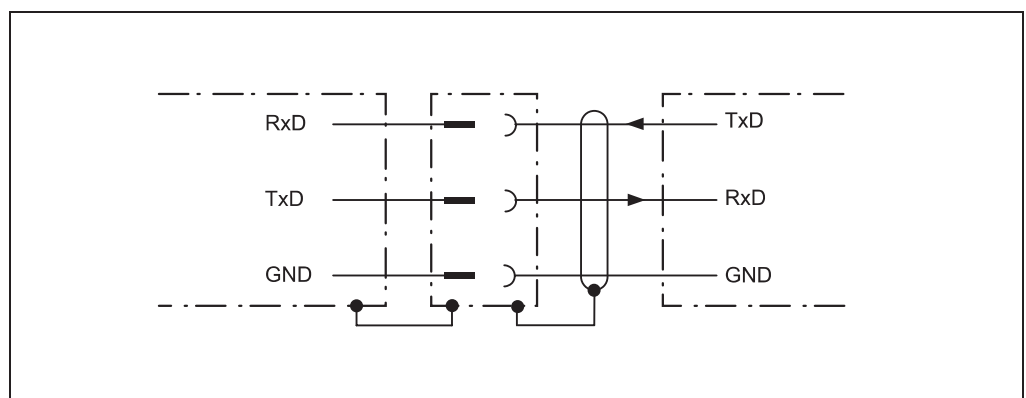

Fig. 32: Wiring the RS-232 interface

Wiring the RS-422 interface

A screened cable is required for the wiring of the RS-422 interface.

- Pay attention to max. cable length as per [section 5.3.3 “General conditions for the data interface” on page 50.](#)

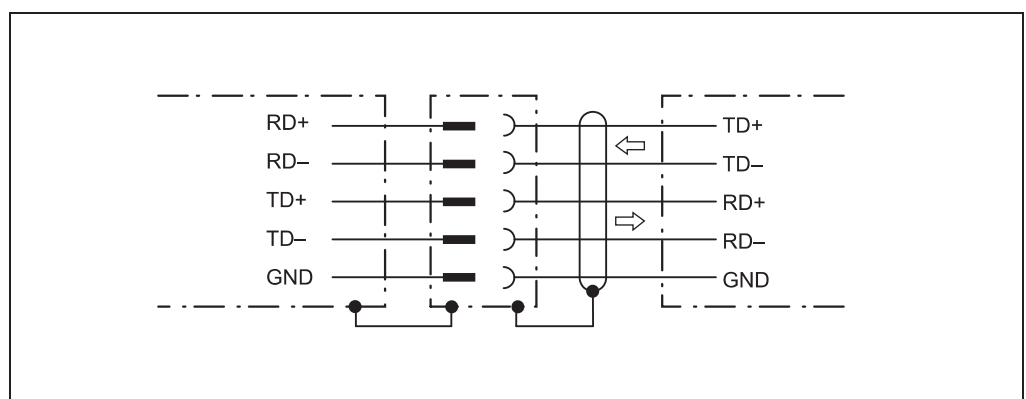

Fig. 33: Wiring the RS-422 interface

5.4.2 Connection of the LD-LRS1000 with pre-assembled cables

Pre-assembled cables are available for the LD-LRS1000, these can be used, for example to connect a PC via RS-232 or Ethernet.

Temperature range 0...+40 °C (32...104 °F).

Connection	Part number	Length	Version
LD-LRS1000 on PC (RS-232)	6032508	3 m (9.84 ft)	RS-232 null modem cable, 3-core, screened, 15 pin D-Sub HD socket to 9 pin D-Sub socket for configuration using the PC, for pin assignment see Tab. 23 on page 54
LD-LRS1000 on PC (Ethernet)	6032509	3 m (9.84 ft)	Ethernet cross-over cable, screened, 15 pin D-Sub HD socket to 8 pin RJ-45 plug for configuration using the PC, for pin assignment see Tab. 24 on page 55

Tab. 22: Pre-assembled cable for LD-LRS1000

Pin assignment RS-232 null modem cable Part no. 6032508

9 pin D-Sub socket (PC)		15 pin D-Sub HD socket (LD-LRS1000)	
Pin	Signal	Pin	Signal
1	-	1	DC 24 V
2	RxD	9	TD-/TxD
3	TxD	7	RD-/RxD
4	-	8	TD+
5	GND_Data	4	GND_Data
6	-	5	GND
7	-	2	CAN L
8	-	3	CAN H
9	-	6	RD+
		10	OUT1
		11	TPIP
		12	TPIN
		13	TPOP
		14	TPON
		15	OUT2
Housing	Screen	Housing	Screen

Tab. 23: Pin assignment for the RS-232 null modem cable Part No. 6032508

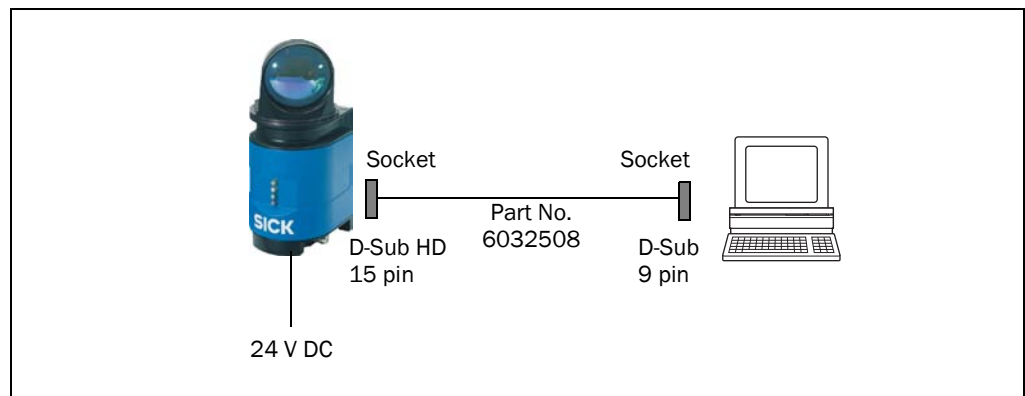

Fig. 34: LD-LRS1000: RS-232 connection using null modem cable part no. 6032508

LD-LRS

Pin assignment Ethernet cross-over cable Part No. 6032509

RJ-45 connector (PC)		15 pin D-Sub HD socket (LD-LRS1000)	
Pin	Signal	Pin	Signal
		1	DC 24 V
		9	TD-/TxD
		7	RD-/RxD
		8	TD+
		4	GND_Data
		5	GND
		2	CAN L
		3	CAN H
		6	RD+
		10	OUT1
1	TPOP	11	TPIP
2	TPON	12	TPIN
3	TPIP	13	TPOP
6	TPIN	14	TPON
		15	OUT2
Housing	Screen	Housing	Screen

Tab. 24: Pin assignment Ethernet cross-over cable Part No. 6032509

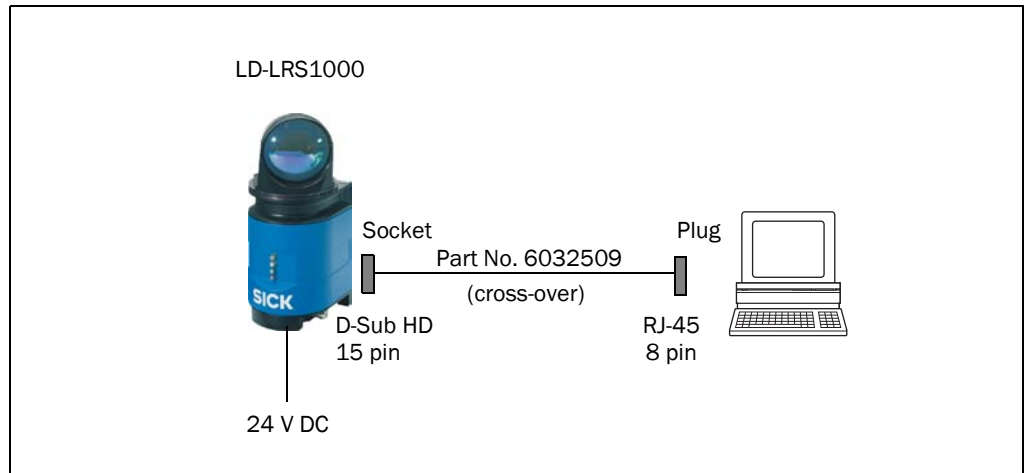

Fig. 35: LD-LRS1000: Ethernet connection using the Ethernet cross-over cable part no. 6032509

5.5 Undertaking electrical installation on the LD-LRSx100

5.5.1 Connection of the LD-LRSx100 with pre-assembled cables

A pre-assembled cable is available for the LD-LRSx100 with which the pin assignment for the LD-LRS1000 can be mirrored and the supply of power established.

Connection	Part number	Version	Length
Mirroring of the pin assignment for the LD-LRS1000 as well as for the supply of power	6032770	Configuration cable in Y version, screened, comprising a plug housing with 20 pin Harting socket, from which the following are derived: 1 × adapter cable for RS-232/RS-422/CAN/Ethernet, screened, with 15 pin D-Sub HD plug (LD-LRS1000 connection diagram), for pin assignment see Tab. 26 on page 56 . 1 × power supply cable for electronics, 2-core, screened, with flying leads	0.2 m (0.66 ft) 3 m (9.84 ft)

Tab. 25: Pre-assembled cable for LD-LRSx100

Configuration cable pin assignment Part No. 6032770

20 pin Harting socket		15 pin D-Sub HD plug		Power supply (flying lead)	
Pin	Signal	Pin	Signal	Colour	Signal
1	DC 24 V_HZG	1	DC 24 V	Red	DC 24 V (electronics)
2	DC 24 V	2	CAN L	Black	GND (electronics)
3	OUT1	3	CAN H		
4	OUT3	4	GND_Data		
5	-	5	GND		
6	TD-/TxD	6	RD+		
7	TD+	7	RD-/RxD		
8	CAN H	8	TD+		
9	TPOP	9	TD-/TxD		
10	TPON	10	OUT1		
11	GND_HZG	11	TPIP		
12	GND	12	TPIN		
13	OUT2	13	TPOP		
14	OUT4	14	TPON		
15	GND_Data	15	OUT2		
16	RD-/RxD				
17	RD+				
18	CAN L				
19	TPIP				
20	TPIN				
Housing	Screen	Housing	Screen		

Connection diagram LD-LRS1000

Flying leads to power supply

Tab. 26: Configuration cable pin assignment Part No. 6032770

With the aid of the configuration cable and the pre-assembled cable for the LD-LRS1000 (see [Tab. 22 on page 54](#)), connections can then be made, for example, from a PC via RS-232 or Ethernet to the LD-LRSx100. [Fig. 36](#) and [Fig. 37](#) show a schematic representation of the connection using the different cables.

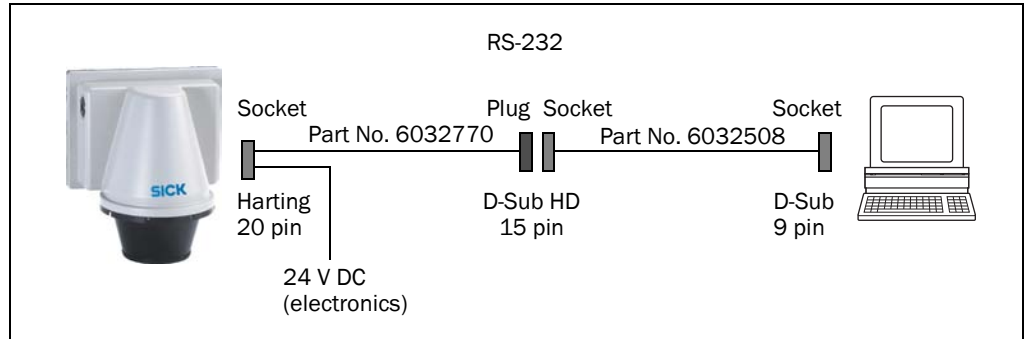

Fig. 36: LD-LRSx100: RS-232 connection using the configuration cable part no. 6032770

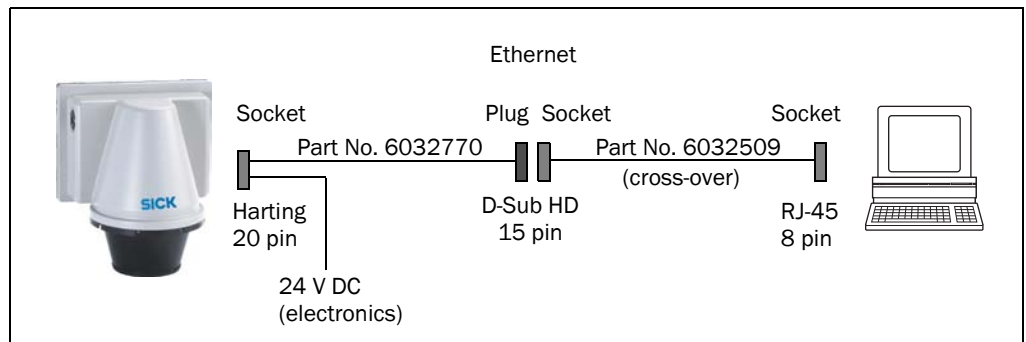

Fig. 37: LD-LRSx100: Ethernet connection using the configuration cable part no. 6032770

Important For the connection of the LD-LRS to a hub/switch, an RJ-45 coupling (2 × socket) and a standard cross-over cable are also required.



Fig. 38: RJ-45 connector

6 Commissioning and configuration



WARNING

Commissioning requires a thorough check by qualified personnel!

Before you operate a system equipped with the LD-LRS for the first time, make sure that the system is first checked and released by qualified personnel. On this issue, observe the notes in chapter 2 **“For your safety” on page 10**.

Commissioning, configuration and diagnostics are undertaken using the SOPAS ET configuration software supplied.

6.1 Overview of the commissioning steps

- Install SOPAS ET configuration software.
- Establish communication with the LD-LRS.
- Create a custom parameter set using SOPAS ET and save in non-volatile memory in the LD-LRS.
- Test LD-LRS for correct function.

6.2 SOPAS ET configuration software

The interactive configuration is undertaken with the aid of SOPAS ET. Using this configuration software, you can configure and test the measurement properties, the analysis behaviour and the output properties of the system as required. The configuration data can be saved as a parameter set (project file) on the PC and archived.

Help for the program user interface as well as for the different options can be found in SOPAS ET:

- menu HELP, HELP F1: comprehensive online help for the program interface and the different options
- HELP window (on the bottom left in the program user interface): context sensitive help for the visible dialog
- tool tips: Move the mouse pointer over an input field. A short text (“tool tip”) with information about valid entries appears.

Primary functions are:

- selection of the menu language (German/English)
- establishment of the communication with the LD-LRS
- password-protected configuration with different operating levels
- system diagnostics

6.2.1 System requirements for SOPAS ET

- standard Intel Pentium PC or compatible, at least Pentium III, 500 MHz
- minimum 256 MB RAM, 512 MB RAM recommended
- data interface RS-232, RS-422, Ethernet or CAN (see also [section 5.3.3 “General conditions for the data interface” on page 50](#))
- operating system: MS Windows 2000, XP or VISTA

- monitor with 256 colours minimum, 65536 colours recommended (16 Bit High Color)
Screen resolution at least 800 × 600
- hard disc: minimum 170 MB free memory
- CD-ROM drive
- HTML browser on PC, e.g. Internet Explorer™: for the online help system for SOPAS ET

6.2.2 Installation of SOPAS ET

1. Start PC and insert installation CD.
2. If the installation does not start automatically, run the file setup.exe on the CD-ROM.
3. To complete the installation, follow the instructions.

6.2.3 SOPAS ET default setting

Parameter	Value
Language for the user interface	English (the software must be re-started after a change)
Units of length	Metric
User group (operating level)	Machine operator
Download the parameters to the LD-LRS	Immediate on change, temporary in the LD-LRS RAM
Upload the parameters from LD-LRS	After switching online, automatic
Window layout	3 (project tree, help, working area)
Serial communication	COM1: 9600 Bd/19200 Bd, 8 data bits, no parity, 1 stop bit

Tab. 27: SOPAS ET default setting

6.3 Establish communication with the LD-LRS

Important For communication via TCP-IP, the TCP-IP protocol must be active on the PC.

On the connection of PC/host, following this sequence:

1. Switch on the PC.
2. Connect PC to the LD-LRS using data cable.
3. Switch on the supply voltage for the LD-LRS.
The LD-LRS performs a self-test and initialises itself.

6.3.1 Connect the data interfaces

➤ Connect PC and laser measurement system together as per table.

Variant	Data interface	Comment
LD-LRS1000	RS-232/RS-422	Connect PC (serial interface) to the LD-LRS using null modem cable (see Fig. 34 on page 54).
	Ethernet	Connect PC to the LD-LRS using Ethernet cross-over cable (see Fig. 35 on page 55).
LD-LRSx100	RS-232/RS-422	Connect PC (serial interface) to the LD-LRS using Y version configuration cable and null modem cable (see Fig. 36 on page 57).
	Ethernet	Connect PC to the LD-LRS using Y version configuration cable and Ethernet cross-over cable (see Fig. 36 on page 57).

Tab. 28: Connect the data interfaces

6.3.2 Starting SOPAS ET and opening scan assistant

1. Start SOPAS ET.
By default SOPAS ET opens the program window with the English user interface.
2. To change the language setting, in the start dialog box click CANCEL and using the menu TOOLS, OPTIONS change the language for the user interface to GERMAN/DEUTSCH.
3. If the language setting has been modified, quit SOPAS ET and re-start.
4. In the dialog box, choose the option CREATE NEW PROJECT and confirm with OK.
5. In the main window in SCAN ASSISTANT click the CONFIGURATION button.
The SCAN ASSISTANT dialog box appears.

6.3.3 Configuring the serial connection

1. In the SCAN ASSISTANT dialog box, under SERIAL CONNECTION, STANDARD PROTOCOL, activate the checkbox ACTIVATE SERIAL COMMUNICATION.
2. Click ADVANCED... button.
3. In COLA DIALECT choose the BINARY option.
4. In BAUD RATE deactivate all baud rates except 115200.
5. Choose following PORT SETTINGS: 8 data bits, no parity, 1 stop bit.
6. Confirm the settings with OK.
The ADVANCED SCAN SETTINGS dialog box is closed.
7. Confirm the settings in the SCAN ASSISTANT dialog box with OK.
The SCAN ASSISTANT dialog box is closed.

6.3.4 Configuring the Ethernet connection

Important Deactivate all programs on your PC/notebook that access Ethernet or TCP/IP.

1. In the SCAN ASSISTANT dialog box, under INTERNET PROTOCOL, IP COMMUNICATION, activate the checkbox ACTIVATE IP COMMUNICATION.
2. Click ADD button.
3. Enter IP address for the LD-LRS (192.168.1.10 is set in the factory).
4. Confirm with OK.
5. Click ADVANCED... button.
6. In COLA DIALECT choose the BINARY option.
7. In DUPLEX MODE choose the HALF DUPLEX option.
8. Confirm the settings with OK.
The ADVANCED SCAN SETTINGS dialog box is closed.
9. Confirm the settings in the SCAN ASSISTANT dialog box with OK.
The SCAN ASSISTANT dialog box is closed.

6.3.5 Performing scan for devices in SOPAS ET

1. In the SCAN ASSISTANT dialog box, click on the START SCAN button.
2. Choose devices listed and accept using ADD DEVICE.
A scan is performed for devices connected via the connection. SOPAS ET adds the devices found to the project tree and uploads the actual parameter set from the device.

6.4 Initial commissioning

The LD-LRS is adapted to the local measurement situation using SOPAS ET. For this purpose a custom parameter set is created using SOPAS ET. The parameter set can either be loaded initially from the device (upload) or it can be prepared independently.

The parameter set is then loaded into the LD-LRS (download). This action is performed either immediately (SOPAS ET option DOWNLOAD IMMEDIATELY) or using a command.

Important Once the configuration has been completed, the parameter set must be saved in non-volatile memory in the laser measurement system. In addition, the parameter set can be saved as a project file (spr file with configuration data) on the PC and archived.

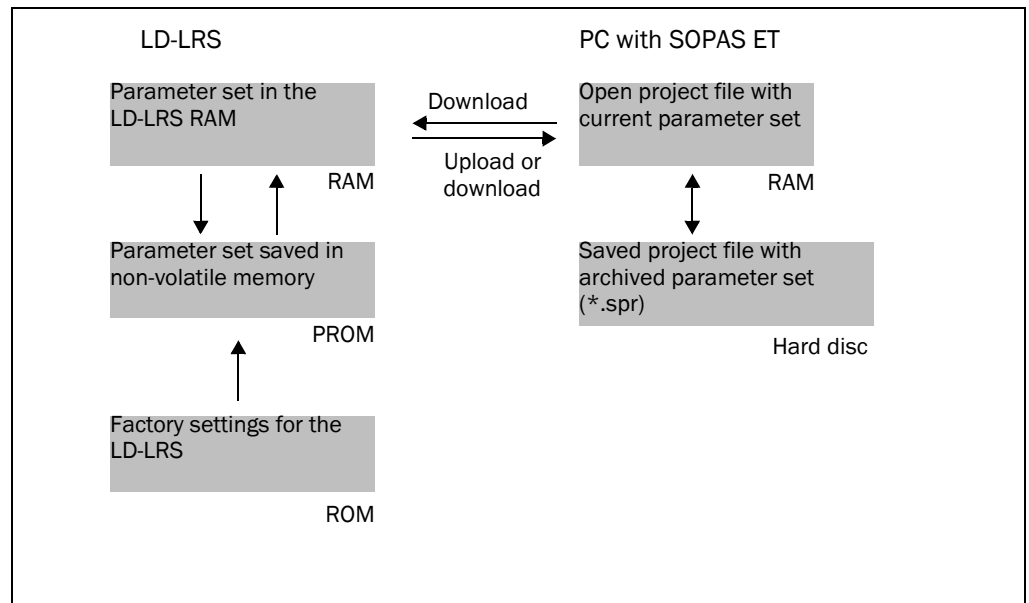

Fig. 39: Principle of data storage

6.4.1 Configuring the LD-LRS

You can configure the LD-LRS in two ways:

- interactively using SOPAS ET
This section describes the interactive configuration.
- using configuration messages
On this subject please read section [3.9.1 “Data communication using messages”](#) on [page 30](#).

Interactive configuration using SOPAS ET

All parameters that can be configured for the LD-LRS are combined into a corresponding device description (jar file) for SOPAS ET. You can open this file using the device description project tree.

The function of each parameter is explained in context-sensitive online help ([F1](#) key). The valid range of values and the default are listed in the PARAMETER INFO window (right mouse button when the pointer is positioned over the parameter).

Important Software access to the LD-LRS is password protected. Following completion of the configuration, you should change the password so that it can perform its protective function.

Firmware	User level	Password
V 2.4 or higher	Authorised client	client

Tab. 29: Passwords

6.5 Performing the configuration

Use the project tree in SOPAS ET to configure the parameters necessary for your application.

1. From the OPTIONS menu select the LOGIN DEVICE command and log in to the system using the password "client" as AUTHORISED CLIENT.

NOTICE

Do not switch off the voltage supply during configuration!

Switching off the voltage supply during configuration causes all parameters already configured to be lost.

2. Configure the LD-LRS for the required application with the aid of the parameters in SOPAS ET.



Help for the program user interface as well as for the different options can be found in SOPAS ET.

6.6 Connection and test measurement

Use the graphic scan view in SOPAS ET to verify the generated measured values and to verify the measurement area online.

1. In the project tree, choose LD_XXXX_APO1, MONITOR, SCAN VIEW.
2. In order to start the measurement, click on PLAY.
3. Compare the measurement line with the desired result.

- Important**
- The SCAN VIEW in the MONITOR is dependent on the available computing power of the PC and is **not** output in real-time. For this reason not all measured values are displayed. The same limitation also applies when saving measured values displayed in a file.
 - The monitor displays the measured values **unfiltered**, i.e. the action of filters can **not** be checked with the aid of the monitor.
4. After completing the test measurement successfully, save the configuration permanently to the LD-LRS: Menu LD_XXXX_APO1, PARAMETER, SAVE PERMANENT.

7 Maintenance

NOTICE

Claims under the warranty rendered void!

The housing screws of the LD-LRS are sealed. Claims under the warranty against SICK AG will be rendered void if the seals are damaged or the device opened. The housing is only allowed to be opened by authorised service personnel.

7.1 Maintenance during operation

The LD-LRS is maintenance-free apart from the maintenance measures listed below. No maintenance is necessary to ensure the retention of laser class 1.

Recommendation

To obtain the full performance of the LD-LRS, the optics in the LD-LRS1000 and the cover on the LD-LRSx100 must be regularly checked for contamination. This applies particularly in harsh operating environments (dust, powder, moisture, finger marks).

NOTICE

Damage to the optics in the LD-LRS1000 or the cover on the LD-LRSx100!

The optics in the LD-LRS1000 are made of glass, the covers for the LD-LRSx100 are made of plastic. The optical power is reduced by scratches and smearing on the front screen.

- Do not use aggressive detergents.
 - Do not use abrasive cleaning agents.
 - Only use use fabric cleaning cloths, never paper tissues.
 - Avoid scratching or scouring movements on the optics or cover.
-

NOTICE

Particles of dust will adhere to the optics in the LD-LRS1000 or on the cover for the LD-LRSx100 due to static charging. You can prevent this effect by using the antistatic plastic cleaner (SICK part number 5600006) and the SICK lens cloth (part number 4003353).



Fig. 40: Optics for the LD-LRS1000 or cover for the LD-LRSx100

How to clean the optics for the LD-LRS1000 or the cover for the LD-LRSx100:

- Switch off the LD-LRS1000 while performing cleaning, as otherwise the scanner head will rotate.
- Remove the dust from the optics or the cover using a clean, soft brush.
- Then wipe off the optics or the cover using a clean, moist cloth.

Important If the optics or the cover is scratched or damaged (cracked, broken), it must be replaced. Please contact the SICK Service.

7.2 Disposal

After de-commissioning, dispose of unusable or irreparable devices in an environmentally correct manner:

1. Observe national waste disposal regulations.
2. Dismantle the housing of the LD-LRS.
3. Remove electronics assemblies.
4. Remove optics and glass components and send for glass recycling.
5. Send chassis and cover for die-cast aluminium recycling.
6. Dispose of all electronic assemblies as hazardous waste.

SICK AG does not accept any devices returned that have become unusable or are irreparable.

7.3 Replacement of a system or replacement of components

As all external cable connections end in the interface adapter or in the 20 pin plug connector, it is not necessary to re-install the device electrically on a device replacement. The replacement device can be simply placed on the adapter and connected to the 20 pin plug connector.

If the system or individual components are replaced, proceed as follows:

1. Switch off the voltage supply for the LD-LRS.
2. Remove connection cable/s from the LD-LRS.
3. Mount the replacement device (see chapter 4 “Mounting” on page 37).
4. Configure replacement device (see chapter 6 “Commissioning and configuration” on page 58).

7.3.1 Checking and replacing desiccant cartridge

The LD-LRSx100 has a desiccant cartridge that is screwed to the right side of the device with an air-tight seal and absorbs any moisture in the device.

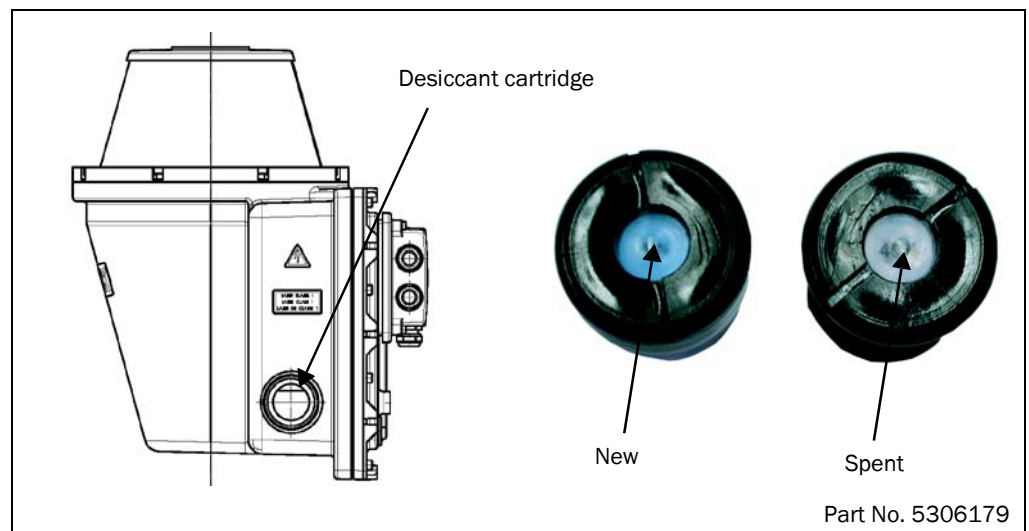

Fig. 41: Position of the desiccant cartridge

The desiccant cartridge is equipped with a moisture indicator for 40% relative humidity behind the round window. When new the indicator is blue; a green coloration indicates that the cartridge is spent and replacement is necessary.

The desiccant cartridge part no. 5306179 can be purchased as a spare part from SICK AG and has an M36×1.5 (0.06 in) thread.

On the replacement of the desiccant cartridge, ensure you make the change quickly, so that no moisture can enter the device! If the device is exposed (unprotected) do not change in rain, fog or snow. If possible, the cartridge is to be changed indoors.

How to replace the desiccant cartridge:

1. Switch off the supply voltage for the LD-LRS.
2. Place new cartridge at hand in the transparent packaging (tube). Do not remove cartridge yet!
3. Unscrew spent cartridge from the transparent packaging with the aid of the groove on the base and remove from the opening.

4. Remove new cartridge from the transparent packaging, fit in the opening and with the aid of the groove on the bottom tighten lightly. During this action pay attention to correct seating (rubber seal).
5. Tighten cartridge to a tightening torque of 1.5 ± 0.2 Nm using a torque wrench.
6. Switch back on supply voltage.

8 Troubleshooting

NOTICE

Claims under the warranty rendered void!

The housing screws of the LD-LRS are sealed. Claims under the warranty against SICK AG will be rendered void if the seals are damaged or the device opened. The housing is only allowed to be opened by authorised service personnel.

This chapter describes how to identify and rectify errors and malfunctions during the operation of the LD-LRS.

8.1 In the event of faults or errors



WARNING



Cease operation if the cause of the malfunction has not been clearly identified!

Stop the machine/system if you cannot clearly identify or allocate the error and if you cannot safely rectify the malfunction.

8.2 Monitoring error and malfunction indications

The LD-LRS monitors itself in operation:

- After switching on the supply voltage the LD-LRS runs through a self-test prior to initialisation (loading the parameter set and initialisation of the device functions); during this self-test the device checks important hardware components.
- During operation the LD-LRS continuously monitors the function of the rotation of the scanner head.
- If the LD-LRS1000 detects a device error during the self-test or in operation, it indicates this situation using the LEDs. The coded errors can be read with the aid of the user protocol services.

8.3 Troubleshooting and rectification

Fault	Possible cause	Solution
1. All LEDs are off and the scanner head is not rotating.	<ul style="list-style-type: none"> No supply voltage at the connection terminals 	<ul style="list-style-type: none"> ➤ Check supply voltage (24 V DC \pm20%). ➤ Check whether supply cables in the interface adapter are correctly screwed to the terminal strip. ➤ Check whether cables are connected to the correct terminals.
2. No LED is illuminated. The scanner head only rotates briefly.	<ul style="list-style-type: none"> Excessively low supply voltage at the connection terminals 	<ul style="list-style-type: none"> ➤ Increase wire cross-section.
3. Red LED illuminated.	<ul style="list-style-type: none"> Scanner head does not rotate and is locked 	<ul style="list-style-type: none"> ➤ With the aid of SOPAS ET, release the lock on the scanner head. ➤ Disconnect supply voltage and re-connect. If the red LED is still illuminated, inform SICK service.
4. SOPAS ET cannot communicate with the LD-LRS.	<ul style="list-style-type: none"> Supply voltage for LD-LRS not switched on 	<ul style="list-style-type: none"> ➤ See 1., 2. and 3.
	<ul style="list-style-type: none"> PC not connected to LD-LRS 	<ul style="list-style-type: none"> ➤ Connect PC to LD-LRS (use data cable to suit interface type).
	<ul style="list-style-type: none"> Wrong interface selected 	<ul style="list-style-type: none"> ➤ Select interface in SOPAS ET as per the connection made to the PC.
	<ul style="list-style-type: none"> Another application on the PC is already accessing the interface. 	<ul style="list-style-type: none"> ➤ Check assignment of the interface, if necessary quit related application.
	<ul style="list-style-type: none"> Pay attention to sequence when switching on the LD-LRS and the PC connected 	<ul style="list-style-type: none"> ➤ 1. Switch on PC, 2. Connect PC to LD-LRS, 3. Switch on LD-LRS.
5. Measurements in the near range with no measurement target.	<ul style="list-style-type: none"> Contaminated or scratched optics 	<ul style="list-style-type: none"> ➤ Carefully clean optics using soft, fluff-free cloth. If the optics are scratched, contact SICK service.
6. Measurements outside the area defined.	<ul style="list-style-type: none"> Directly incident sunlight 	<ul style="list-style-type: none"> ➤ Reduce scanning area. ➤ Avoid directly incident sunlight using suitable shielding.
7. The LD-LRS does not detect objects present.	<ul style="list-style-type: none"> Smoke and dust 	<ul style="list-style-type: none"> ➤ Check whether the scanner head is clean and dry.
8. The LD-LRS is not transmitting a measured result.	<ul style="list-style-type: none"> Wiring fault in the data connection 	<ul style="list-style-type: none"> ➤ Check wiring.
9. Frequent CRC error on the RS-232 interface.	<ul style="list-style-type: none"> Data transmission time critical 	<ul style="list-style-type: none"> ➤ Increase the baud rate. ➤ Restrict scanning area. ➤ Reduce angular resolution. ➤ Reduce scanning frequency.

Tab. 30: Troubleshooting and rectification

8.4 Detailed error analysis

The LD-LRS outputs occurring errors in various ways. Errors are output in stages and always permit detailed analysis:

- Communication errors can occur on the transfer of messages to the LD-LRS. The LD-LRS then returns an error code.
- In case of status errors occurring during a scan, error codes are written to a status log.

8.4.1 Querying status log

- Important**
- The status protocol is retained also after the device is switched off and on again.
 - The LD-LRS differentiates between four error types: “Information”, “Warning”, “Error” and “Serious error”. For each error type, the system saves only the last five occurrences.

Displaying log with the aid of SOPAS ET

You can display this logfile using SOPAS ET:



- Connect SOPAS ET to the device.
- Open the project tree LD_XXXX_AP01, SERVICE, SYSTEM STATUS, Area SYSTEM STATUS.

9 Technical specifications

9.1 Data sheet LD-LRS laser measurement system

Type	LD-LRS1000	LD-LRS2100/3100	LD-LRS4100/5100
Measurement area ¹⁾²⁾			
At 10% remission	0.5...80 m (1.64...262.47 ft)	2.5...80 m (8.2...262.47 ft)	
At 20% remission	0.5...114 m (1.64...374.02 ft)	2.5...114 m (8.2...374.02 ft)	
Maximum	250 m (820.21 ft) distance		
Effective scan angle	360°	300°	300°
Angular resolution (step width)	0.125°, can be selected between 0.125°...1.5°		
Scanning frequency	5...10 Hz ±5% in steps of 1 Hz		
Measurement resolution	3.9 mm (1/256 m) (0.15 in)		
Systematic error ¹⁾	±38 mm (±1.5 in) at 20...90% remission (±63 mm (±2.48 in) with 80 m (262.47 ft) distance or more)		
Statistical error (1 σ)	30 mm (1.18 in) at 20...90% remission		
Beam divergence	2.8 mrad (0.160°)		
Light emission	Via rotating scanner head		
Laser diode (wavelength)	Infrared light ($\lambda = 905$ nm)		
Pulse frequency	Max. 14.4 kHz (10.8 kHz mean over 360°)		
Laser class of the device	Class 1 (as per IEC 60825-1, complies with 21 CFR 1040.10 with the exception of the deviations as per Laser Notice No. 50, July 26, 2001.), eye safe		
Optical indicators	4 × LED (status displays)	-	-
Serial data interface	RS-232/RS-422	LD-LRS2100: RS-232 LD-LRS3100: RS-422	LD-LRS4100: RS-232 LD-LRS5100: RS-422
Data transmission rate	4800, 9600, 19200, 38400, 57600, 115200 Bd		
Data format	8 data bits, 1 stop bit, no parity, fixed output format		
Data transmission rate CAN	10 Bit/s...1 MBit/s, maximum cable length 30 m (98.43 ft)		
Ethernet data interface	10 MBit/s, TCP/IP		
Switching outputs	4 × (OUT1 to OUT4)		1 × (OUT3)
Properties	Semiconductor "Highside", maximum output current due to load 0.5 A at 24 V DC in each case		
Relay outputs	-	-	2 × (REL1.1 and 1.2, REL2.1 and 2.2)
Switching current			0.5 A DC or AC ³⁾
Switching voltage			Maximum 25 V AC or 60 V DC ⁴⁾
Electrical connections	1 × 6-way terminal block via PG7 cable entry (\varnothing maximum 5.6 mm (0.22 in)), for power supply/4 switching outputs 1 × 15 pin D-Sub HD plug for data interfaces, power supply and 2 switching outputs	1 × 20 pin Harting plug	
Operating voltage for electronics	24 V DC ±15% as per IEC 364-4-41 (VDE 0100, part 410)		
Operating voltage for heating	-	24 V DC (maximum 6 V residual ripple)/maximum 6 A cyclic, 144 W	
Power consumption for electronics	Switching on: maximum 36 W (1.5 A) ⁵⁾ at 24 V DC, on power up briefly 51 W (2.1 A)		
Housing	Aluminium die casting	PUR-IHS ⁶⁾	PUR-IHS ⁶⁾

Tab. 31: Data sheet LD-LRS laser measurement system

LD-LRS

Type	LD-LRS1000	LD-LRS2100/3100	LD-LRS4100/5100
Enclosure rating as per EN 60529 (1991-10); A1 (2002-02)	IP 65	IP 67	IP 67
Protection class as per EN 61140 (2002-03)	III		
EMC test	As per EN 61000-6-2/ EN 61000-6-3	As per EN 61000-6-2/EN 61000-6-4	
Vibration test ⁷⁾	As per IEC 68, part 2-6, table 2c (frequency range 10...150 Hz, amplitude 0.35 mm (0.01 in) or 5 g)	As per IEC 68, part 2-6, table 2c (frequency range 10...55 Hz, amplitude 2 g)	
Shock test ⁷⁾	Single shock: as per IEC 68, part 2-27, table 2 (15 g/11 ms) Continuous shock: as per IEC 68, part 2-29 (10 g/16 ms)		
Weight	Approx. 4.1 kg (9.04 lb)	Approx. 9.1 kg (20.06 lb)	Approx. 9.1 kg (20.06 lb)
Ambient operating temperature/ storage temperature	0...+50 °C/-20...+80 °C	-25...+50 °C ⁸⁾ /-25...+70 °C	
Max. relative air humidity	5...85%, non-condensing		
Housing colour	SICK blue (RAL 5012), black	Grey (RAL 7032), black	
Fastening	8 × fastening thread M6 × 12 (0.47 in)	4 × fastening thread M8 × 9 (0.35 in)	

Tab. 31: Data sheet LD-LRS laser measurement system

- 1) Condition: Laser beam completely incident on the object, warm-up time of 30 min observed.
- 2) In case of operation without near range suppression.
- 3) No current peaks (current rush) above 0.5 A are allowed.
- 4) Safety extra-low voltage EN 50178.
- 5) If switching outputs not connected.
- 6) PUR-IHS: polyurethane integral foam.
- 7) In case of high vibration and shock load (e.g. AGS application) anti-vibration mounts are recommended.
- 8) Warming up time approx. 90 min at -25 °C (-13 °F), approx. 80 min at -20 °C (-4 °F).

9.2 Response times

The response times of the LD-LRS are dependent on the following factors:

- configured response time of the output
- configured scanning frequency
- physical response time of the output

How to determine the response time of the LD-LRS:

$$t_{ges} = t_{rd} + t_{out}$$

t_{ges} = Total response time of the system

t_{rd} = Rounded response time of the output

t_{out} = Physical response time of the output

Configured response time of the output

The response time configured in SOPAS ET for the output (see [“Response time of the output” on page 29](#)) is rounded to a multiple of the scan time for the LD-LRS.

Scanning frequency	Scan time	Examples for	
		configured response times	rounded response times
5 Hz	200 ms	2500 ms	2600 ms
6 Hz	166 ms	1000 ms	1162 ms
7 Hz	140 ms	2000 ms	2100 ms
8 Hz	125 ms	400 ms	500 ms
9 Hz	111 ms	1500 ms	1554 ms
10 Hz	100 ms	1000 ms	1000 ms

Tab. 32: Scan times

Physical response times of the outputs

Output	Configuration	Response time
Digital output	Active high	0 ms
Digital output	Active low	2 ms
Relay output	Active high	4 ms
Relay output	Active low	4 ms

Tab. 33: Physical response times of the outputs

9.3 Dimensional drawings

9.3.1 Dimensional drawing LD-LRS1000

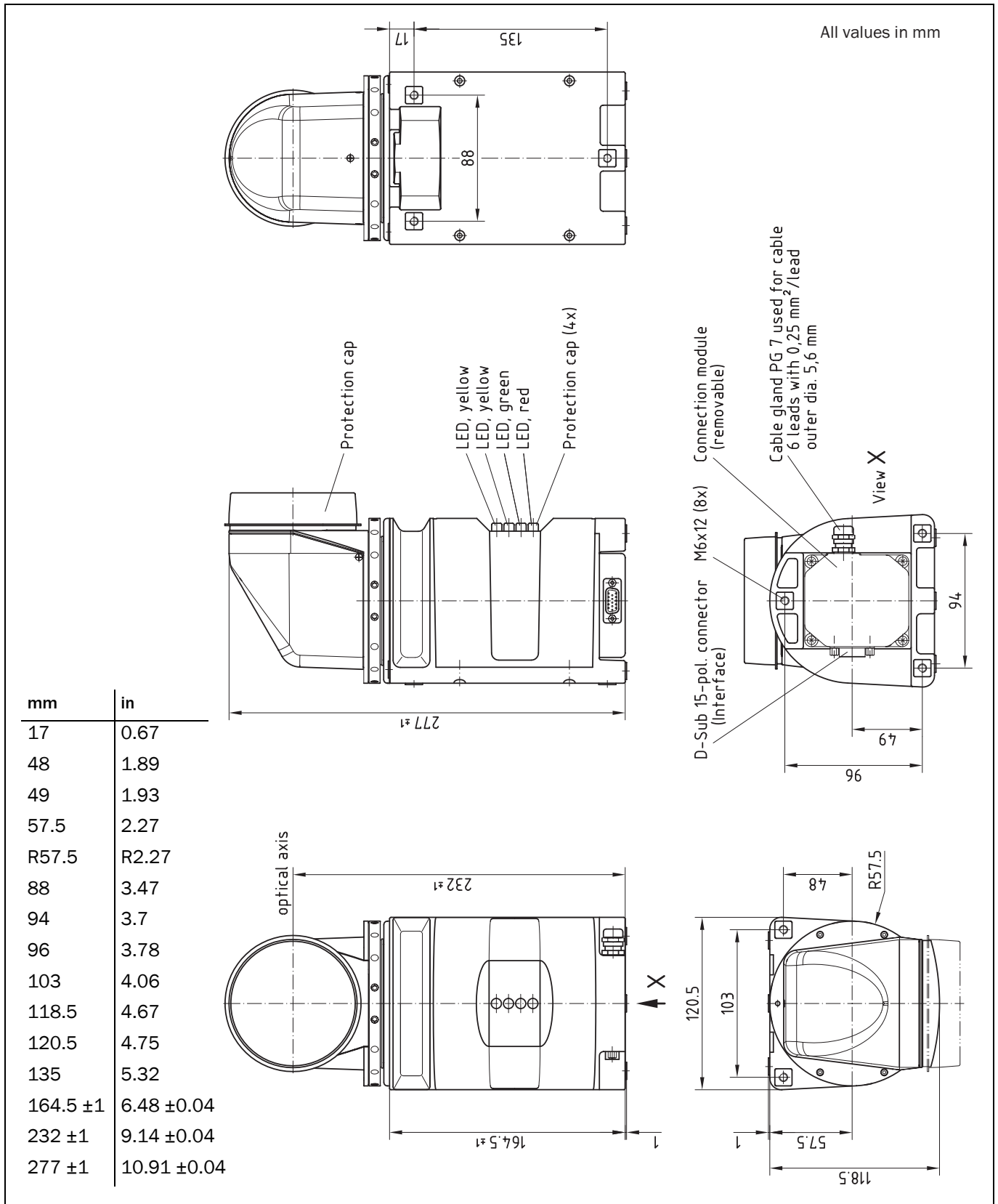

Fig. 42: Dimensional drawing LD-LRS1000

9.3.2 Dimensional drawing LD-LRS2100, 3100, 4100 and 5100

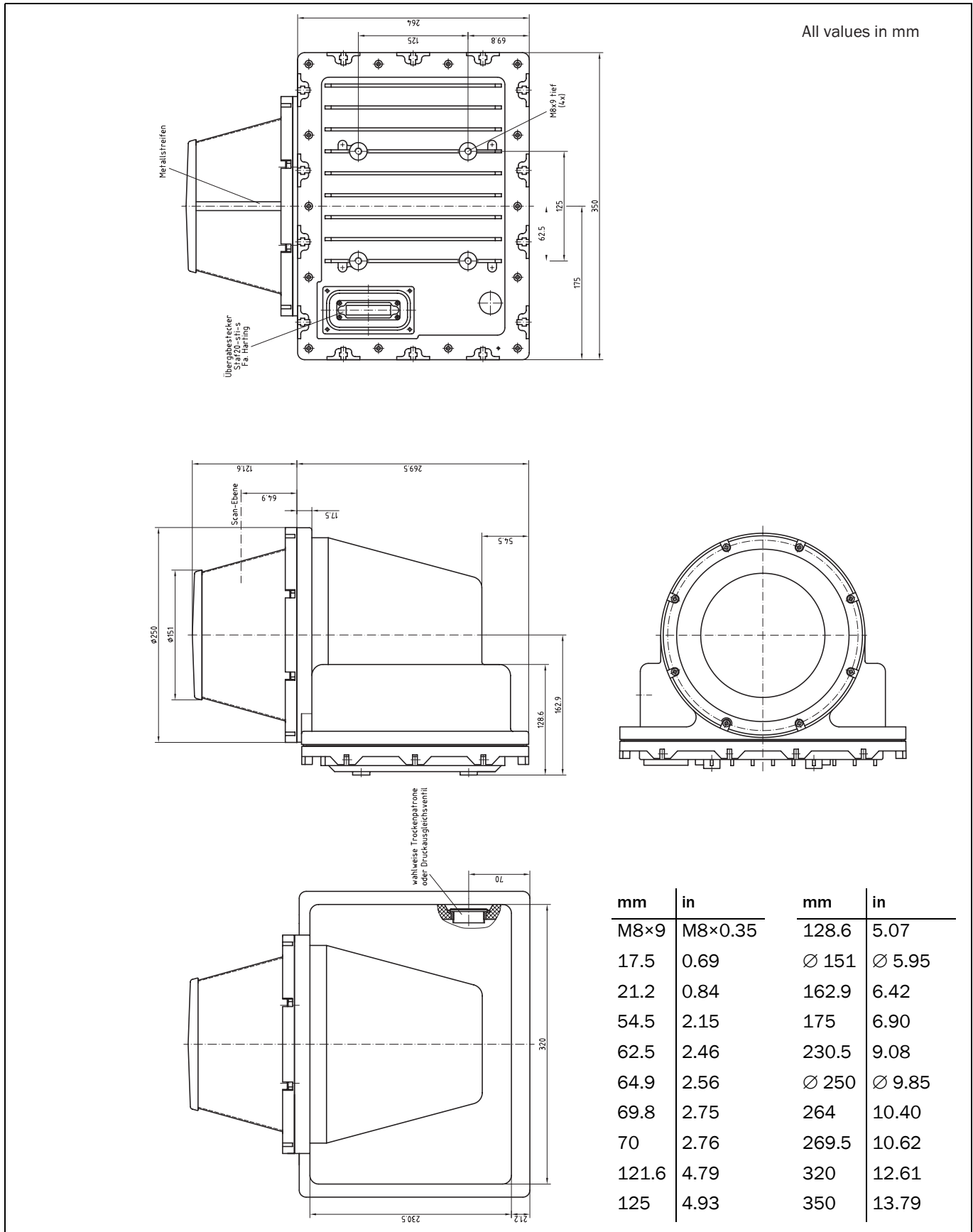

Fig. 43: Dimensional drawing LD-LRS2100, 3100, 4100 and 5100

9.3.3 Dimensional drawing bracket for LD-LRS1000

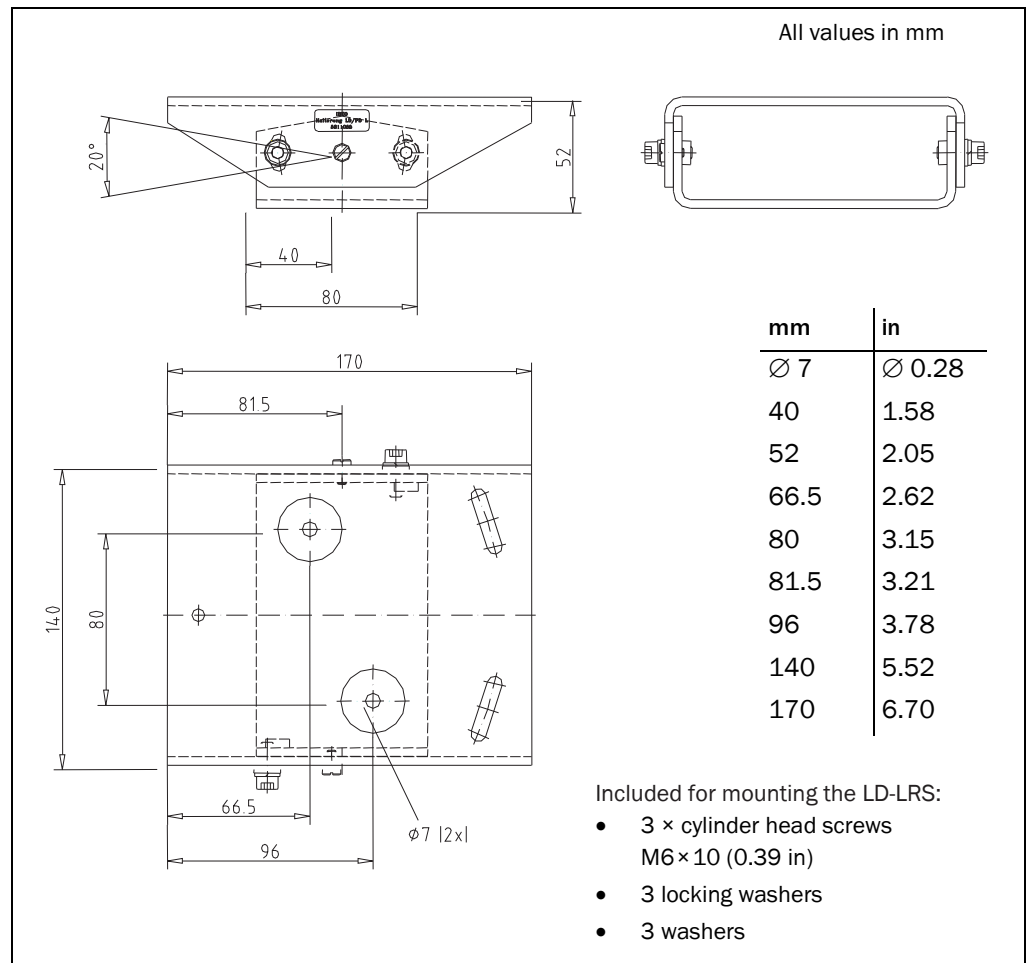

Fig. 44: Dimensional drawing bracket for LD-LRS1000

9.3.4 Dimensional drawing bracket for LD-LRS2100, 3100, 4100 and 5100

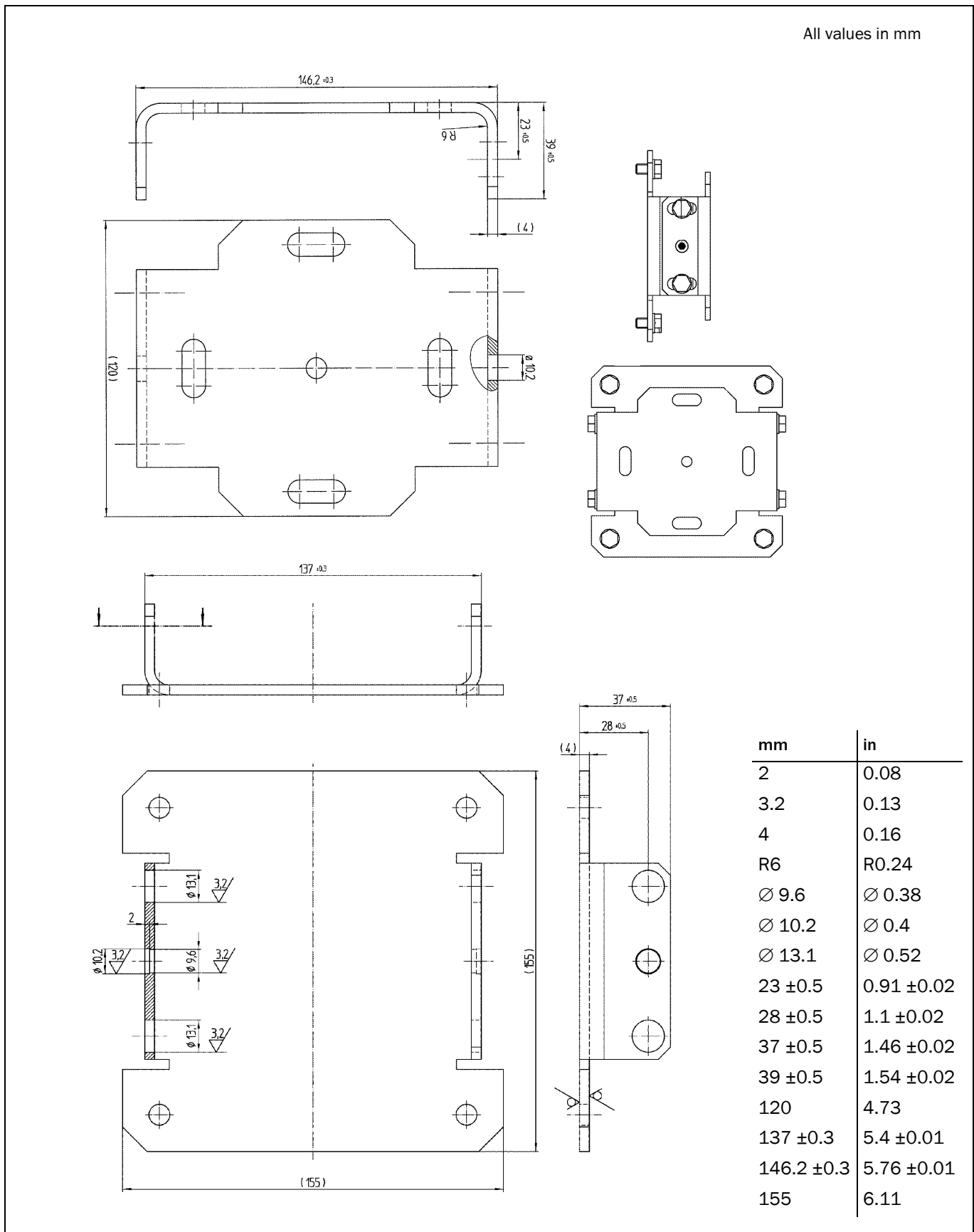

Fig. 45: Dimensional drawing bracket for LD-LRS 2100, 3100, 4100 and 5100

9.3.5 Dimensional drawing mast bracket for LD-LRS2100, 3100, 4100 and 5100

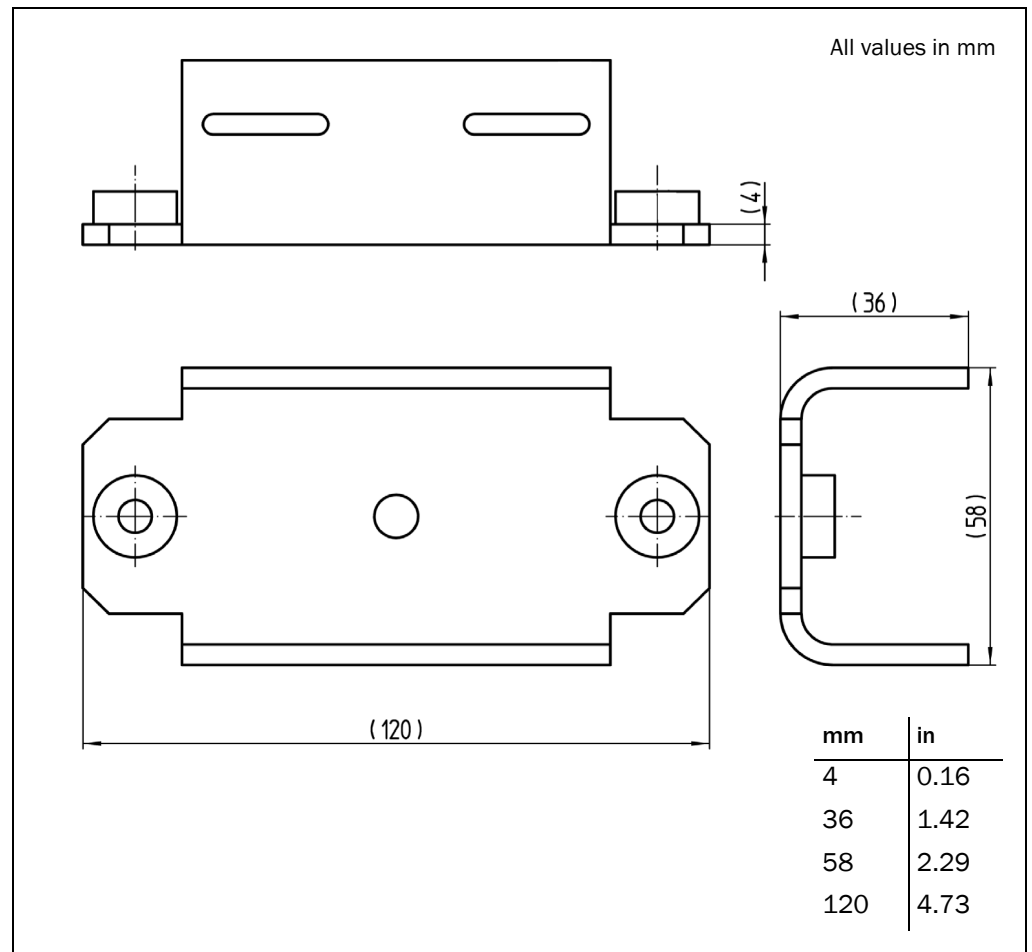

Fig. 46: Dimensional drawing mast bracket for LD-LRS 2100, 3100, 4100 and 5100

10 Annex

10.1 Overview of the annexes

The annex contains the following supplementary information:

- data communication via the data interfaces
- ordering information
- glossary
- illustration containing the EU Declaration of Conformity

10.2 Data communication via the data interfaces

This chapter describes the data communication on the RS-232, RS-422, CAN and Ethernet data interface on the LD-LRS; communication is based on protocols.



The contents of the individual messages is described in the message listing “TLLDOEMLRSen” on the CD-ROM supplied.

10.2.1 Terminology

Term	Meaning
BYTE	Without sign, 8 bits
WORD	Without sign, 16 bits
User Service	Service request to control the LD-LRS
User Protocol Frame (UPF)	Contains a service request comprising service code and data
UPF packet	A UPF can be divided into UPF packets. The UPF packets contain headers so that the original UPF can be assembled again
Interface packet (IF packet)	A UPF packet with information, dependent on the interface type

Tab. 34: Data communication: terminology

10.2.2 Addressing

CAN is a fieldbus system developed for the communication of several devices on a single connection. If several sensors and host computers are connected together, a mechanism must differentiate between the users on such a network. For this reason each user is allocated a unique address, the network node number (ID). A data frame sent over the network contains the network node numbers (ID) of the communication partners.

- SID source ID (identifies the sender)
- DID destination ID (identifies the recipient)

SID and DID are BYTE variables with a value between 1 and 254 (0 is reserved as the broadcast address, 255 is reserved for the application processor in the LD-LRS).

RS-232 is always a point-to-point connection, for this reason addressing is unnecessary. To maintain the consistency of the protocol for all interface types, addressing is nevertheless used and also evaluated on the RS-232 interface.

10.2.3 Frame format for the user protocol

Service requests and their replies are transmitted as a block of n words (WORDS), where the first word represents the service code, followed by n-1 service data words. If the service request/reply is transmitted over an external interface, the service request/reply is termed the User Protocol Frame.

User Protocol Frame	
1 WORD	n-1 WORDS
Service code	Service data

Tab. 35: Data communication: frame format

The number of data words (WORDS) that follows the service code is described indirectly by the service code itself or written in the service data. BYTE data are packed in the service data using the big endian format, this means:

Within a BYTE sequence of k BYTES (counted from 0 to k-1) the data bytes with the even ordinal numbers are written to the more significant byte and their successors to the less significant byte of the same data word.

Example:

Packing the BYTE string “Hello” in service data

WORD[1]		WORD[2]		WORD[3]	
Hi	Lo	Hi	Lo	Hi	Lo
“H”	“e”	“l”	“l”	“o”	

Tab. 36: Data communication: example for packing a BYTE string in the big endian format

10.2.4 Separation and re-assembly of packets

The communication in CAN networks is based on the exchange of data packets. The size of a data packet may vary, but is limited to a maximum size. This is:

- 4 words (WORDS) in one CAN packet (termed CAN message)
- 128 words (WORDS) in an RS-232/RS-422 packet

To transmit a user protocol frame, it is necessary to break it down into several parts. These parts are each supplemented with a header and are termed User Protocol Frame packets, or UPF packets for short. The length of a UPF packet is dependent on the interface used (see [“Packet formats on external interfaces” on page 80](#)).

The receiving node must re-assemble these packets into the original user protocol frame. Each UPF packet contains a packet header that provides information for the correct assembly of the frame.

The packet header comprises two words (WORDS):

1. Sequence Flag

A sequence of packets is a number of UPF packets that contain data on the same user protocol frame. The sequence flag marks the first packet in a sequence of packets; the other packets do not have a sequence flag.

2. Packet ID

The packet ID for the first UPF packet contains the number of packets necessary to complete the actual frame (including the first packet). Each subsequent packet in this

sequence has a packet ID value the same as the packet ID value for the previous packet, reduced by the value 1. For this reason the last packet in the sequence has the packet ID value 1.

Packet header		Packet data
Sequence Flag	Packet ID	
FFFFh	0002...FFFFh	

Tab. 37: Data communication: header format for the first UPF packet in a packet sequence

Packet header		Packet data
Packet ID		
0001...FFFEh		

Tab. 38: Data communication: header format for the following UPF packets in a packet sequence

Exception:

If a user protocol frame fits completely in only one packet, the sequence flag is suppressed and the packet ID has the value 0.

Packet header		Packet data
Packet ID		
0000h		

Tab. 39: Data communication: header format for a UPF packet sequence comprising a single packet

Example for the breakdown:

Frame	k, n	Meaning
1. frame: complete in 1 packet	k = 0	Frame data, single packet
2. frame: complete in 1 packet	k = 0	Frame data, single packet
3. frame: broken down down into 4 packets	n = FFFFh, k = 4	Frame data, first packet
3. frame (continued)	k = 3	Frame data, second packet
3. frame (continued)	k = 2	Frame data, third packet
3. frame (continued)	k = 1	Frame data, last packet
4. frame: complete in 1 packet	k = 0	Frame data, single packet
n is the value of the sequence flag, k is the packet ID value		

Tab. 40: Data communication: example for the packet breakdown

10.2.5 Packet formats on external interfaces

To be able to send a UPF packet to an interface, it must be inserted in an interface packet (IF packet). The header format for an IF packet is different for the RS-232/RS-422, Ethernet and CAN interface, individual packet sizes vary and the characteristics of the interface must be taken into account. One CAN message corresponds to the IF packet.

A common feature of all external interfaces is the mechanism for the separation and re-combination of packets.

10.2.6 Packet transmission via RS-232/RS-422

The IF packet format for the serial interface is structured as follows:

Word	Contents	Meaning
0	SID	Source address (more significant BYTE)
	DID	Target address (less significant BYTE)
1	LEN	Number of data words that follow, including CRC (max. 126)
2 to LEN	DATA	UPF packet data, including packet header (max. 125 words), see chapter 10.5.4 <i>Separation and re-assembly of packets</i> , page 10-6
LEN + 1	CRC	Checksum, directly after the packet data

Tab. 41: RS-232/RS-422 interface: IF packet format

The 16-bit CRC value is calculated over all words (WORDS) (from SID to the last data word), except the CRC word itself. A “C” code example for the checksum calculation is given in [“C” code example for the CRC calculation \(RS-232/RS-422\)](#) on page 84. The polynomial used for the CRC generator is 1021h:

$$g(x) = x^{16} + x^{12} + x^5 + 1$$

The start value for the CRC is FFFFh.

All data values in an RS-232/RS-422 frame are transmitted as hexadecimal ASCII, the hexadecimal numbers Ah to Fh are coded using upper or lower case. The CRC value is calculated before the ASCII coding.

Example:

The decimal data word value 41853 is the hexadecimal A37Dh. As a result the four ASCII letters “a37d” are transmitted. The byte sequence is 61h 33h 37h 64h.

The IF packet is transmitted in the big endian format: The more significant byte is transmitted first. The packet starts with an STX (02h) and ends with an ETX (03h).

A complete IF packet for the RS-232/RS-422 interface contains max. 514 bytes.

Byte number	Meaning	Number of bytes
0	STX	1
1	SID	2
3	DID	2
5	LEN	4
9	DATA	LEN × 4
...
(LEN × 4) + 9	CRC	4
(LEN × 4) + 10	ETX	1

Tab. 42: RS-232/RS-422 interface: number of bytes in the complete IF packet

Transmission control:

The host can send the control character XON (11h)/XOFF (13h) to signal to the LD-LRS that it is not allowed to send data (XOFF) or is allowed to send (XON). These control characters are not sent by the LD-LRS.

RS-232/RS-422 communication parameters

The data format is fixed: 8 data bits, 1 stop bit, no parity

Possible baud rates are:

- 4800 Bd
- 9600 Bd
- 19200 Bd
- 38400 Bd
- 57600 Bd
- 115200 Bd

Error handling

If an overflow or checksum error occurs while the LD-LRS is receiving a packet, it send an NAK (15h) to the host to indicate that the actual packet will be ignored and the actual frame will be discarded.

10.2.7 Packet transmission via Ethernet

Structure of the UPF packet in the user service protocol



The structure of the UPF packet in the UPS (User Protocol Service) is given in the following. Service code and service data are the same as the format described in the message listing "TLLDOEMLRSen".

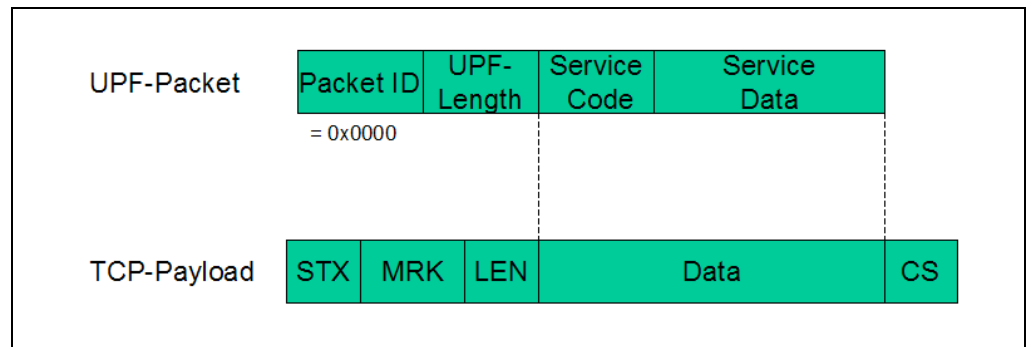

Fig. 47: Structure of the UPF packet in the user service protocol

STX "Start of text", is transmitted as a single byte, 02h.

MRK Definition of the transmission format "UPS" = 55h, 53h, 50h (3 bytes)

LEN UPF-Length = The number of bytes that follow in <data> is coded as a 32-bit integer (four bytes) without a sign; the most significant byte must be transmitted first.

CS Checksum, is a single byte that is calculated using an exclusive OR operator on all bytes in "Data".

10.2.8 Packet transmission via CAN

In CAN networks the data transmitted (CAN messages) have a unique identifier. Because the message identifier is used directly in the bus arbitration process, different nodes must not send a message with the same identifier, as the message identifier indirectly identifies the source node.

The last 8 significant bits of the CAN message identifier contain the host ID for messages that the host has sent. They contain the LD-LRS ID for messages that the LD-LRS has sent. Identifiers used by the host are coded in the following manner:

$TxHostCanId = TxHostCanBaseId \text{ BITOR } SID$

Identifier used by the LD-LRS are coded in the following manner:

$TxSensorCanId = TxSensorCanBaseId \text{ BITOR } SID$

$TxHostCanBaseId$ and $TxSensorCanBaseId$ are 11-bit identifier base values and configurable parameters.

A CAN message corresponds to one IF packet and comprises:

- identifier
- data block length code
- user data, max. 8 Bytes (incl. packet header and packet data)

The error monitoring is performed by the hardware in the CAN controller. This adds a CRC to the CAN message during transmissions and checks the CRC during reception. The polynomial used makes possible very reliable error monitoring such that a CAN message received can be assumed to be error-free.

CAN packet transmission

For the CAN communication the header in the UPF packet is expanded to add the destination node address (DID) and a reserved byte for the word alignment. Sequence flag, DID and the reserved byte are only sent in the first packet in a packet sequence. The packet header in all other packets in a packet sequence only contains the packet ID.

Packet header			Packet data	
WORD	WORD	WORD	WORD	
Sequence Flag	Packet ID	Reserved	DID	
FFFFh	0002...FFFFh	0	1...FFh	

Tab. 43: CAN interface: format of the first UPF packet in a packet sequence

Packet header	Packet data
WORD	Max. 3 WORDS
Packet ID	
0001...FFFEh	

Tab. 44: CAN interface: format of the following UPF packets in a packet sequence

Exception:

If a user protocol frame fits completely in only one packet (a UPF packet contains max. 2 data words), the sequence flag is suppressed and the packet ID has the value 0.

Packet header		Packet data	
WORD	WORD	Max. 2 WORDS	
Packet ID	Reserved	DID	
0000h	0	1...FFh	

Tab. 45: CAN interface: format for a single packet sequence

CAN communication parameter

The LD-LRS uses standard identifiers (11 bits, CAN 2.0A), the parameters for the bit timing for different baud rates are:

Baud rate	Nominal bit time	Length of the time quantum (T_q)	TSEG1 [T_q]	TSEG2 [T_q]	SJW [T_q]	Sample Point
1 MBit/s	1 μ s	50 ns	14	3	2	15 T_q , 800 ns
500 kBit/s	2 μ s	100 ns	15	2	1	17 T_q , 1.70 μ s
250 kBit/s	4 μ s	250 ns	12	1	1	14 T_q , 3.5 μ s
125 kBit/s	8 μ s	500 ns	12	1	1	14 T_q , 7 μ s
50 kBit/s	20 μ s	1.25 μ s	12	1	1	14 T_q , 17.5 μ s
20 kBit/s	50 μ s	2.5 μ s	15	2	1	17 T_q , 42.5 μ s
10 kBit/s	100 μ s	6.25 μ s	12	1	1	14 T_q , 87.5 μ s

Tab. 46: CAN communication parameter: timing parameter

Error handling

The actual packet is ignored and the frame discarded if ...

- an overflow occurs.
- a packet has an incorrect packet ID.

10.2.9 "C" code example for the CRC calculation (RS-232/RS-422)

Example C code to calculate a CRC sum:

```

/*
*****
Project:    generic project
File:      crc16c.c
           CRC16 calculation
Version:    V0.0.1
Date:      20.09.1998
*****
Abstract:
  routines for calculating a 16 bits CRC signature using the generator
  polynom  $x^{16} + x^{12} + x^5 + 1$  as recommended by the ITU.T V.42
  (former CCITT); all routines use a table driven algorithm
-----
Modification History:
0.0.1 20.09.1998
      created
*****/
#define CRC16_C
// includes
#include "cpu-dep.h"
//
=====
// local scope defines
// (global scope in separate header file: this_file.h)
//
=====
// local scope macros
// (global macros in separate header file: this_file.h)

```

```

//
=====
// local scope type definitions
// (global scope in separate header file: this_file.h)
//
=====
// local scope prototype declarations (type modifier: PRIVATE)
// (global scope in separate header file: this_file.h)
//
=====
// global scope global variable definitions (type modifier: PUBLIC)
//
=====
// local scope global variable definitions (type modifier: PRIVATE)
// XOR table for CRC algorithm, CRC-16, ITU.T X.25
// polynomial: h1021
PRIVATE const WORD crctab[256] =
{
    0x0000, 0x1021, 0x2042, 0x3063, 0x4084, 0x50a5, 0x60c6, 0x70e7,
    0x8108, 0x9129, 0xa14a, 0xb16b, 0xc18c, 0xd1ad, 0xe1ce, 0xf1ef,
    0x1231, 0x0210, 0x3273, 0x2252, 0x52b5, 0x4294, 0x72f7, 0x62d6,
    0x9339, 0x8318, 0xb37b, 0xa35a, 0xd3bd, 0xc39c, 0xf3ff, 0xe3de,
    0x2462, 0x3443, 0x0420, 0x1401, 0x64e6, 0x74c7, 0x44a4, 0x5485,
    0xa56a, 0xb54b, 0x8528, 0x9509, 0xe5ee, 0xf5cf, 0xc5ac, 0xd58d,
    0x3653, 0x2672, 0x1611, 0x0630, 0x76d7, 0x66f6, 0x5695, 0x46b4,
    0xb75b, 0xa77a, 0x9719, 0x8738, 0xf7df, 0xe7fe, 0xd79d, 0xc7bc,
    0x48c4, 0x58e5, 0x6886, 0x78a7, 0x0840, 0x1861, 0x2802, 0x3823,
    0xc9cc, 0xd9ed, 0xe98e, 0xf9af, 0x8948, 0x9969, 0xa90a, 0xb92b,
    0x5af5, 0x4ad4, 0x7ab7, 0x6a96, 0x1a71, 0x0a50, 0x3a33, 0x2a12,
    0xdbfd, 0xcdbc, 0xfbff, 0xeb9e, 0x9b79, 0x8b58, 0xbb3b, 0xab1a,
    0x6ca6, 0x7c87, 0x4ce4, 0x5cc5, 0x2c22, 0x3c03, 0x0c60, 0x1c41,
    0xedae, 0xfd8f, 0xcdec, 0xddcd, 0xad2a, 0xbd0b, 0x8d68, 0x9d49,
    0x7e97, 0x6eb6, 0x5ed5, 0x4ef4, 0x3e13, 0x2e32, 0x1e51, 0x0e70,
    0xff9f, 0xefbe, 0xdfdd, 0xcffc, 0xbf1b, 0xaf3a, 0x9f59, 0x8f78,
    0x9188, 0x81a9, 0xb1ca, 0xa1eb, 0xd10c, 0xc12d, 0xf14e, 0xe16f,
    0x1080, 0x00a1, 0x30c2, 0x20e3, 0x5004, 0x4025, 0x7046, 0x6067,
    0x83b9, 0x9398, 0xa3fb, 0xb3da, 0xc33d, 0xd31c, 0xe37f, 0xf35e,
    0x02b1, 0x1290, 0x22f3, 0x32d2, 0x4235, 0x5214, 0x6277, 0x7256,
    0xb5ea, 0xa5cb, 0x95a8, 0x8589, 0xf56e, 0xe54f, 0xd52c, 0xc50d,
    0x34e2, 0x24c3, 0x14a0, 0x0481, 0x7466, 0x6447, 0x5424, 0x4405,
    0xa7db, 0xb7fa, 0x8799, 0x97b8, 0xe75f, 0xf77e, 0xc71d, 0xd73c,
    0x26d3, 0x36f2, 0x0691, 0x16b0, 0x6657, 0x7676, 0x4615, 0x5634,
    0xd94c, 0xc96d, 0xf90e, 0xe92f, 0x99c8, 0x89e9, 0xb98a, 0xa9ab,
    0x5844, 0x4865, 0x7806, 0x6827, 0x18c0, 0x08e1, 0x3882, 0x28a3,
    0xcb7d, 0xdb5c, 0xeb3f, 0xfb1e, 0x8bf9, 0x9bd8, 0xabbb, 0xbb9a,
    0x4a75, 0x5a54, 0x6a37, 0x7a16, 0x0af1, 0x1ad0, 0x2ab3, 0x3a92,
    0xfd2e, 0xed0f, 0xdd6c, 0xcd4d, 0xbdaa, 0xad8b, 0x9de8, 0x8dc9,
    0x7c26, 0x6c07, 0x5c64, 0x4c45, 0x3ca2, 0x2c83, 0x1ce0, 0x0cc1,
    0xef1f, 0xff3e, 0xcf5d, 0xdf7c, 0xaf9b, 0xbfba, 0x8fd9, 0x9ff8,
    0x6e17, 0x7e36, 0x4e55, 0x5e74, 0x2e93, 0x3eb2, 0x0ed1, 0x1ef0
};
//
=====
// global scope function definitions (type modifier: PUBLIC)
/*
-----
Function:   block_crc16_byte

```

Abstract: calculates CRC16 signature of a block of bytes
 Version: 1

Return value:
 type functional description
 WORD CRC signature

Importlist:
 type identifier functional description
 BYTE* data pointer to data block
 WORD numofbytes number of bytes in data block
 WORD initial_crc initial CRC value
 WORD[] crctab CRC XOR table (as global variable)

Exportlist:
 type identifier functional description
 none

```

  */
  PUBLIC WORD block_crc16_byte
  (
    BYTE* data,
    WORD numofbytes,
    WORD initial_crc
  )
  {
    WORD crc = initial_crc;
    while( numofbytes-- )
      crc = ( (crc << 8) | *data++ ) ^ crctab[crc>>8];
    return crc;
  }
  /*
  
```

Function: block_crc16_word
 Abstract: calculates CRC16 signature of a block of data words (16bit)
 Version: 1

Return value:
 type functional description
 WORD CRC signature

Importlist:
 type identifier functional description
 WORD* data pointer to data block
 WORD numofbytes number of bytes (not words!) in data block
 WORD initial_crc initial CRC value
 WORD[] crctab CRC XOR table (as global variable)

Exportlist:
 type identifier functional description
 none

```

  */
  PUBLIC WORD block_crc16_word
  (
    WORD* data,
    WORD numofbytes,
  
```

LD-LRS

```

    WORD  initial_crc
  )
  {
    register WORD d;
    register WORD crc = initial_crc;

    numofbytes >>= 1;
    while( numofbytes-- )
    {
      d = *data++;
      crc = ( (crc << 8) | ((BYTE)( d >> 8 ) ) ) ^ crctab[crc>>8];
      crc = ( (crc << 8) | ((BYTE) d ) ) ^ crctab[crc>>8];
    }
    return crc;
  }
  /*

```

```

-----
Function:  crc16_byte
Abstract:  calculates CRC16 signature of a single data byte
Version:   1
-----

```

```

Return value:
type      functional description
WORD      CRC signature
-----

```

```

Importlist:
type      identifier      functional description
BYTE      data            data byte
WORD      initial_crc     initial CRC value
WORD[]    crctab          CRC XOR table (as global variable)
-----

```

```

Exportlist:
type      identifier      functional description
none
-----

```

```

  /*
PUBLIC WORD crc16_byte
(
  BYTE  data,
  WORD  initial_crc
)
{
  register WORD crc = initial_crc;

  crc = ( (crc << 8) | data ) ^ crctab[crc>>8];
  return crc;
}
  /*

```

```

-----
Function:  crc16_word
Abstract:  calculates CRC16 signature of a single data word (16bit)
Version:   1
-----

```

```

Return value:
type      functional description
WORD      CRC signature
-----

```

Importlist:

type	identifier	functional description
WORD	data	data word
WORD	initial_crc	initial CRC value
WORD[]	crctab	CRC XOR table (as global variable)

Exportlist:

type	identifier	functional description
none		

```

-----
*/
PUBLIC WORD crc16_word
(
    WORD data,
    WORD initial_crc
)
{
    register WORD crc = initial_crc;

    crc = ((crc << 8) | ((BYTE)( data >> 8 ) ) ) ^ crctab[crc>>8];
    crc = ((crc << 8) | ((BYTE) data ) ) ^ crctab[crc>>8];
    return crc;
}

//
=====
// local scope function definitions (type modifier: PRIVATE)
//
=====
// EOF crc16.c
Example C code to generate the CRC table used in the example above:
#include <stdio.h>
#define CRC_POLY 0x1021
typedef unsigned short WORD;
WORD get_crctab_val
(
    int idx
)
{
    WORD value;
    WORD old_val;
    int k;
    value = ( (WORD) idx ) << 8;
    for( k=0; k<8; k++ )
    {
        old_val = value;
        value <<= 1;
        if( old_val & 0x8000 ) value ^= CRC_POLY;
    }
    return value;
}
void main( void )
{
    FILE *out;
    WORD value;
    int k, i;
    out = fopen( "crctab.c", "wt" );

```



```

if( out == NULL )
{
    puts( "\ncannot generate crctab.c !!\n\n" );
    return;
}
fprintf( out, "// put header here\n\n" );
fprintf( out, "#include \"cpu-dep.h\"\n\n" );
fprintf( out, "// XOR table for CRC algorithm, CRC-16, ITU.T X.25\n" );
fprintf( out, "// polynomial: h%4x\n\n", CRC_POLY );
fprintf( out, "const WORD crctab[256] = \n" );
fprintf( out, " {" );
i = 0;
for( k=0; k<256; k++ )
{
    value = get_crctab_val( k );
    if( i == 0 )
        fprintf( out, "\n 0x%04x", value );
    else if( k >= 248 && i >= 7 )
        fprintf( out, " 0x%04x", value );
    else
        fprintf( out, " 0x%04x", value );
    if( ++i >= 8 ) i = 0;
}
fprintf( out, "\n };\n\n" );
fclose( out );
}

```

10.3 Ordering information

10.3.1 Available systems

Part number	Device type	Code
1028941	LD-LRS1000	Laser measurement system with maximum 360° field of view, housing with enclosure rating IP 65, data interfaces CAN, Ethernet, RS-232 (default setting)/ RS-422, 4 digital outputs
1029041	LD-LRS2100	Laser measurement system with maximum 300° field of view, in protective housing with heating (IP 67), data interfaces CAN, Ethernet, RS-232, 4 digital outputs
1029042	LD-LRS3100	Laser measurement system with maximum 300° field of view, in protective housing with heating (IP 67), data interfaces CAN, Ethernet, RS-422, 4 digital outputs
1029037	LD-LRS4100	Laser measurement system with maximum 300° field of view, in protective housing with heating (IP 67), data interfaces CAN, Ethernet, RS-232, 2 relay outputs, 1 digital output
1029038	LD-LRS5100	Laser measurement system with maximum 300° field of view, in protective housing with heating (IP 67), data interfaces CAN, Ethernet, RS-422, 2 relay outputs, 1 digital output

Tab. 47: Available systems

10.3.2 Available accessories

Part number	Description
6032507	Adapter cable for LD-LRS1000, 0.2 m (0.66 ft), twisted pair, screened, 15 pin D-Sub HD socket to 9 pin D-Sub plug. Provides on the 9 pin D-Sub plug the connection arrangement for the previous LD-OEM device.
2014054	RS-232 null modem cable for LD-LRS1000 in combination with cable part no. 6032507, 3-core, 3 m (9.84 ft), twisted pair, screened, 9 pin D-Sub socket to 9 pin D-Sub socket
6032508	RS-232 null modem cable for LD-LRS1000, 3-core, 3 m (9.84 ft), twisted-pair, screened, 15 pin D-Sub HD socket to 9 pin D-Sub socket for configuration using PC
6032509	Ethernet cross-over cable for LD-LRS1000, 3 m (9.84 ft), twisted-pair, screened, 15 pin D-Sub HD socket to 8 pin RJ-45 plug for configuration using PC
6032770	Y version configuration cable for LD-LRSx100 with 20 pin Harting socket. Comprising an adapter cable for RS-232/RS-422/CAN/Ethernet, screened, 0.2 m (0.66 ft), as well as a power supply cable for the electronics with flying leads, screened, 3 m (9.84 ft)
2035130	Interface adapter (spare part) for LD-LRS1000
5311055	Fixing bracket for LD-LRS1000, complete with mounting material and tools
2018303	Adjustable bracket for wall mounting of the LD-LRSx100, metal, weight approx. 1.6 kg (3.53 lb) (including mounting hardware).
2018304	Mast bracket for LD-LRSx100, metal, weight approx. 400 g (14.11 oz) (incl. mounting material).
5306222	Steel clamping strip for mast bracket (by the metre), 19 mm × 0.7 mm (0.75 in × 0.03 in)
5306221	Steel clamping strip lock
5306179	Desiccant cartridge, male thread M36 × 1.5 (0.06 in)
2018301	Complete 16-pin connection plug, with housing
6004379	Plug insert 16-pin (spring strip) for connection plug
6025934	Replacement fuse with holder T5A0, 125 V, SMD
2039808	CD-ROM "Manuals & Software LD-LRS1000...5100"

Tab. 48: Available accessories

10.4 Glossary

Download

Transmission of the parameter set that has been modified offline in the SOPAS ET configuration software from the PC to the LD-LRS. SOPAS ET transmits either always a complete copy to the memory (RAM) in the LD-LRS (menu COMMUNICATION, DOWNLOAD ALL PARAMETERS TO DEVICE) or only the parameter that has just been edited (menu COMMUNICATION, DOWNLOAD MODIFIED PARAMETERS TO DEVICE). With the menu LD-LRS, PARAMETER, SAVE PERMANENT, the parameter set is saved permanently in the flash memory of the LD-LRS.

Field of view α

Angle that defines the limits to which the laser beam is deflected by the polygon mirror wheel. A v-shaped area is formed radially in the scan direction in front of the laser output aperture; this area must contain the objects to be measured.

Line scanner

Scanner that very rapidly deflects its focused laser beam with the aid of a polygon mirror wheel with mirrors parallel to the axis. In this way the scanner generates a dot of light in the measuring plane that repeatedly runs along a straight line and appears to be a "stationary" scan line due to the relative slow response of the human eye.

Parameter set

Data set using which the functions implemented in the LD-LRS are initialised and activated. Is transmitted from the LD-LRS to SOPAS ET and in the reverse direction using UPLOAD or DOWNLOAD respectively.

Remission

Remission is the quality of reflection at a surface. The basis is the Kodak standard, known worldwide in, among other areas, photography.

Scan

A scan encompasses all measured values determined referred to the scanning angle and the speed of rotation of the mirror.

Scan line

See line scanner.

SOPAS ET

Configuration software, can be used with Windows 2000, XP or VISTA. Is used for the offline configuration (adaptation to the read situation on-site) and the online operation of the LD-LRS in the dialog box.

Upload

Transmission of the parameter set from the LD-LRS to the PC into the SOPAS ET configuration software. The values for the parameters are displayed on the file cards of the configuration software. Prerequisite for the modification of the current parameter set.

10.5 Illustration containing the EC Declaration of conformity

Fig. 48 shows page 1 of the EC Declaration of conformity (size reduced). The full EC Declaration of conformity is available on request.

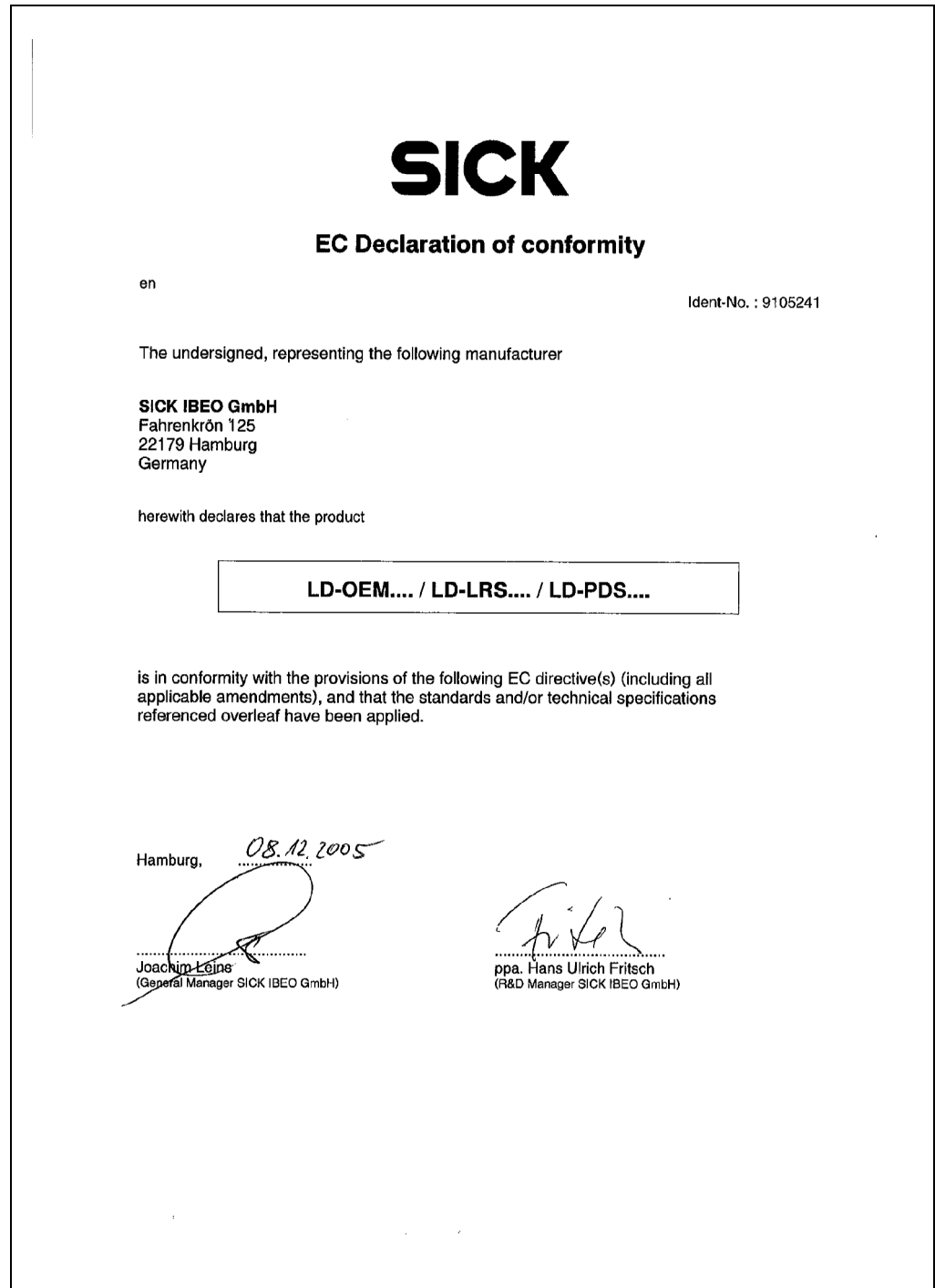

Fig. 48: Illustration containing the EC Declaration of conformity

LD-LRS

LD-LRS

Australia

Phone +61 3 9497 4100
1800 33 48 02 – tollfree
E-Mail sales@sick.com.au

Belgium/Luxembourg

Phone +32 (0)2 466 55 66
E-Mail info@sick.be

Brasil

Phone +55 11 3215-4900
E-Mail sac@sick.com.br

Ceská Republika

Phone +420 2 57 91 18 50
E-Mail sick@sick.cz

China

Phone +852-2763 6966
E-Mail ghk@sick.com.hk

Danmark

Phone +45 45 82 64 00
E-Mail sick@sick.dk

Deutschland

Phone +49 211 5301-270
E-Mail info@sick.de

España

Phone +34 93 480 31 00
E-Mail info@sick.es

France

Phone +33 1 64 62 35 00
E-Mail info@sick.fr

Great Britain

Phone +44 (0)1727 831121
E-Mail info@sick.co.uk

India

Phone +91-22-4033 8333
E-Mail info@sick-india.com

Israel

Phone +972-4-999-0590
E-Mail info@sick-sensors.com

Italia

Phone +39 02 27 43 41
E-Mail info@sick.it

Japan

Phone +81 (0)3 3358 1341
E-Mail support@sick.jp

Nederlands

Phone +31 (0)30 229 25 44
E-Mail info@sick.nl

Norge

Phone +47 67 81 50 00
E-Mail austefjord@sick.no

Österreich

Phone +43 (0)22 36 62 28 8-0
E-Mail office@sick.at

Polska

Phone +48 22 837 40 50
E-Mail info@sick.pl

Republic of Korea

Phone +82-2 786 6321/4
E-Mail kang@sickkorea.net

Republika Slovenija

Phone +386 (0)1-47 69 990
E-Mail office@sick.si

România

Phone +40 356 171 120
E-Mail office@sick.ro

Russia

Phone +7 495 775 05 34
E-Mail info@sick-automation.ru

Schweiz

Phone +41 41 619 29 39
E-Mail contact@sick.ch

Singapore

Phone +65 6744 3732
E-Mail admin@sicksgp.com.sg

Suomi

Phone +358-9-25 15 800
E-Mail sick@sick.fi

Sverige

Phone +46 10 110 10 00
E-Mail info@sick.se

Taiwan

Phone +886 2 2365-6292
E-Mail sickgrc@ms6.hinet.net

Türkiye

Phone +90 216 587 74 00
E-Mail info@sick.com.tr

USA/Canada/México

Phone +1(952) 941-6780
1 800-325-7425 – tollfree
E-Mail info@sickusa.com

More representatives and agencies
in all major industrial nations at
www.sick.com