

DL100 – EtherNet/IP

Distance measuring device



EN



Copyright protection!

This work is copyright-protected. The rights founded by this shall remain with company SICK AG. Reproduction of the work or parts of this work shall only be permissible within the limits of the legal provisions of copyright law. Changes and abbreviations of this work are prohibited without the express written agreement of SICK AG.

Table of contents

1	General	8
1.1	Information on the operating instructions	8
1.2	Explanation of symbols	9
1.3	Limitations of liability	10
1.4	Delivery.....	10
1.5	Customer service.....	10
1.6	EC Declaration of Conformity.....	10
1.7	Environmental protection.....	11
2	Safety.....	12
2.1	Intended use.....	12
2.2	Non-Intended use	12
2.3	Changes and conversions.....	12
2.4	Requirements to skilled persons and operating staff	13
2.5	Work safety and special danger	13
2.6	Warning at the device.....	14
2.7	Danger notes and operational safety.....	15
3	Identification.....	16
3.1	Type label	16
4	Setup and function	17
4.1	Setup	17
4.2	Function.....	18
4.3	Display and operating elements.....	19
4.4	Display	21
5	Transport and storage	22
5.1	Transport.....	22
5.2	Transport inspection.....	22
5.3	Storage	23
6	Mounting	24
6.1	Mounting process.....	24
6.2	Mounting notes.....	24
6.3	Choose and mount reflector	24
6.4	Placement of multiple distance measuring device	26
6.5	Place the distance measuring device towards the adjacent data transmission photoelectric switch.....	27

Table of contents

- 6.6 Align distance measuring device and reflector against each other 28
- 6.7 Mount alignment bracket and distance measuring device . 29
- 6.8 Distance measuring device above alignment bracket 31
- 7 Electrical connection 32**
 - 7.1 Safety..... 32
 - 7.2 Wiring Notes..... 33
 - 7.3 Electrically connect distance measuring device..... 35
 - 7.4 Connection diagrams 36
 - 7.4.1 Connection diagram supply voltage 36
 - 7.4.2 Connection diagram Port 1 and Port 2 (Ethernet/PROFINET IO) 37
- 8 Operation at the measuring device 37**
 - 8.1 Measured value display 37
 - 8.2 Choose parameter 38
 - 8.3 Choose option 38
 - 8.4 Change value 38
 - 8.5 Parameter description..... 39
 - 8.5.1 Main menu 39
 - 8.5.2 Menu "SwVers"..... 39
 - 8.5.3 Menu "HwVers"..... 40
 - 8.5.4 Menu "Profin" 40
 - 8.5.5 Menu "more" 41
 - 8.5.6 Menu "MFx On" 42
 - 8.5.7 Menu "MF1" 43
 - 8.5.8 Submenu "MF1 – Dist" 44
 - 8.5.9 Submenu "MF1 – Speed"..... 45
 - 8.5.10 Submenu "MF1 – Srvce" 46
 - 8.5.11 Submenu "Preset" – move to initialization position47
 - 8.5.12 Menu "MF2" 49
 - 8.5.13 Menu "Offset" 50
 - 8.5.14 Menu “SpecFu” 50
 - 8.6 Perform reset 52

9	Operation via Ethernet (Ethernet interface)	53
9.1	IP-network configuration	53
9.2	Ethernet parameter list	53
9.2.1	Device information	53
9.2.2	User information	54
9.2.3	Measurement values	55
9.2.4	Diagnostic data	56
9.2.5	Parameter settings	57
9.2.6	Methods	65
10	EtherNet/IP-interface	66
11	Cleaning and maintenance	88
11.1	Cleaning	88
11.2	Maintenance	88
12	Troubleshooting	88
12.1	LED status indicators	89
12.2	Warning messages	89
12.3	Error messages	90
12.4	PROFINET IO error messages	91
12.5	Return	92
12.6	Disposal	92
13	Repair	92
14	Technical data	93
14.1	Dimensions	93
14.2	Device selection EtherNet/IP-interface	94
14.3	Laser/optics	94
14.4	Performance	95
14.5	Supply	95
14.6	Inputs	95
14.7	Outputs	96
14.8	Interfaces	96
14.9	Ambient conditions	96
14.10	Constructive setup	97

Table of contents

15	Accessories	98
15.1	Reflectors and reflective tape	98
15.1.1	Reflectors	98
15.1.2	Reflective tape.....	101
15.2	Connection systems	101
15.3	Mounting systems.....	102
15.4	Other accessories.....	103
16	Menu structure.....	104
	Index	106

Important safety notes



NFPA79 applications only.

UL-listed adapters providing field wiring leads are available.

Refer to the product information. → See "www.sick.com/dl100".



CAUTION!

Use of controls or adjustments or performance of procedures other than those specified herein may result in hazardous radiation exposure.

Importantes consignes de sécurité



À utiliser pour les applications NFPA79 uniquement.

Des adaptateurs homologués fournissant des fils de câblage client sont disponibles.

Se reporter aux informations du produit.

→ Voir « www.sick.com/dl100 ».



ATTENTION!

Tout usage de commandes, réglages ou toute application de procédures autres que ceux décrits dans ce document peut entraîner une exposition dangereuse au rayonnement.

General

1 General

1.1 Information on the operating instructions

These operating instructions offer important notes on handling of the distance measuring devices DL100 of SICK AG. A prerequisite for safe work is compliance with all indicated safety notes and instructions.

Furthermore, the local work safety regulations and general safety provisions applicable for the application of the distance measuring device must be complied with.

The operating instructions must be read carefully before taking up any work! They are part of the product and must be kept in direct proximity of the distance measuring device, accessible for the staff at all times.

When passing on the distance measuring device to third parties, the operating instructions must be passed on as well.

1.2 Explanation of symbols

Warnings

Warnings are marked by icons in the operating instructions. The notes are initiated by signal words that express the degree of danger.

Always comply with the notes and act carefully to avoid accidents, injury and property damage.



DANGER!

... indicates a directly dangerous situation that will lead to death or severe injury if not avoided.



WARNING!

... indicates a possibly dangerous situation that may lead to death or severe injury if not avoided.



CAUTION!

... indicates a potentially dangerous situation that may lead to minor or light injury if not avoided.



ATTENTION!

... indicates a potentially harmful situation that may lead to property damage if not avoided.

Advice and recommendations



NOTE!

... emphasizes useful advice and recommendations, as well as information for efficient and trouble-free operation.

General

1.3 Limitations of liability

All notes and information in these instructions were collected under consideration of the applicable standards and regulations, the state of the art and our long-term experience and insights.

The manufacturer does not assume any liability for damage due to:

- Non-observation of the operating instructions
- Non-intended use
- Use of untrained staff
- Unauthorized conversions
- Technical changes
- Use of unapproved wear and tear parts

The actual delivery may deviate from the features and presentations described here for special designs, when additional order options are used or due to the latest technical changes.

1.4 Delivery

The following is included in the delivery:

- Distance measuring device DL100
- Optional: Accessories (→ page 98, chapter 15).

Included documentation per distance measuring device:

- Quickstart

1.5 Customer service

Our customer service is available for technical information.

You can find your local office on the reverse.



NOTE!

For quick processing of the call, keep the data of the type label, such as type code, serial number, etc. ready.

1.6 EC Declaration of Conformity

→ The EC Declaration of Conformity can be downloaded from "www.sick.com".

1.7 Environmental protection



ATTENTION!

Danger for the environment from improper disposal of the distance measuring device!

Improper disposal of the distance measuring device may cause damage for the environment.

Therefore:

- Always observe the applicable environmental protection provisions.
 - Upon proper disassembly, send the disassembled components to recycling.
 - Separate the materials by type and recycle them.
-

Safety

2 Safety

2.1 Intended use

The distance measuring device DL100 is a measuring device consisting of an opto-electronic sensor and integrated assessment electronics. The measuring device is only intended for non-contact recording of distances from linearly moved system parts. Distance measurement is performed by a reflector.

SICK AG assumes no liability for direct or indirect loss or damage resulting from use of the product. This in particular applies for any differing use of the product that does not meet the intended purpose and that is not described or mentioned in this documentation.

2.2 Non-Intended use

The distance measuring device DL100 is no safety component according to the EC Machinery Directive (2006/42/EC).

The distance measuring devices must not be used in explosion-hazardous areas.

All uses not described in intended use are prohibited.

No accessories must be connected or installed that are not expressly specified in amount and characteristics and approved by SICK AG.



WARNING!

Danger from non-intended use!

Any non-intended use may cause dangerous situations.

Therefore:

- Only use the distance measuring device according to its intended use.
 - All information in the operating instructions must be strictly complied with.
-

2.3 Changes and conversions

Changes and conversions at the distance measuring device or the installation may cause unexpected dangers.

The manufacturer's written approval is required before any technical changes and expansions of the distance measuring device.

2.4 Requirements to skilled persons and operating staff



WARNING!

Danger of injury in case of insufficient qualification!

Improper use may cause considerable injury and property damage.

Therefore:

- Any work must be performed by the designated persons only.

The following qualification requirements for the different areas of activity are described in the operating instructions:

- **Instructed persons**
were instructed in the tasks assigned to them and possible dangers in case of improper conduct in the scope of instruction by the operator.
- **Skilled persons**
are able to perform the tasks assigned to them based on their technical training, knowledge and experience, as well as knowledge of the relevant provisions, and to independently recognize possible danger.
- **Electricians**
are able to perform work at electrical systems based on their technical training, knowledge and experience, as well as knowledge of the relevant standards and provisions, and to independently recognize possible dangers.
In Germany, the electrician must meet the provisions of the accident prevention provisions BGV A3 (e.g. Elektroinstallateur-Meister). Other countries are subject to corresponding regulations that must be observed.

2.5 Work safety and special danger

Observe the safety notes listed here and the warnings in the other chapters of these instructions to reduce dangers to health and avoid dangerous situations.

Safety

2.6 Warning at the device

The distance measuring device DL100 has a category 2 laser installed. The measuring device is marked with a warning.



Complies with 21 CFR 1040.10 and 1040.11 except for conformance with IEC 60825-1 Ed. 3, as described in Laser Notice No. 56 dated 8 May 2019.

Laser radiation – Never look into the light beam – Class 2 Laser Product (EN 60825-1:2014+A11:2021; IEC 60825-1:2014)

Laser output aperture

Fig. 1: Warning at the device: Laser category 2 (EN 60825-1:2014+A11:2021; IEC 60825-1:2014)
Identical laser class for issue EN/IEC 60825-1:2007

2.7 Danger notes and operational safety

Laser irradiation

The following notes must be observed and complied with for your own safety:



CAUTION!

Optical radiation: Laser class 2

The human eye is not at risk when briefly exposed to the radiation for up to 0.25 seconds. Exposure to the laser beam for longer periods of time may cause damage to the retina. The laser radiation is harmless to human skin.

- Do not look into the laser beam intentionally.
 - Never point the laser beam at people's eyes.
 - If it is not possible to avoid looking directly into the laser beam, e.g., during commissioning and maintenance work, suitable eye protection must be worn.
 - Avoid laser beam reflections caused by reflective surfaces. Be particularly careful during mounting and alignment work.
 - Do not open the housing. Opening the housing will not switch off the laser. Opening the housing may increase the level of risk.
 - Current national regulations regarding laser protection must be observed.
-

Identification

3 Identification

3.1 Type label

The type label is located on the measuring device.

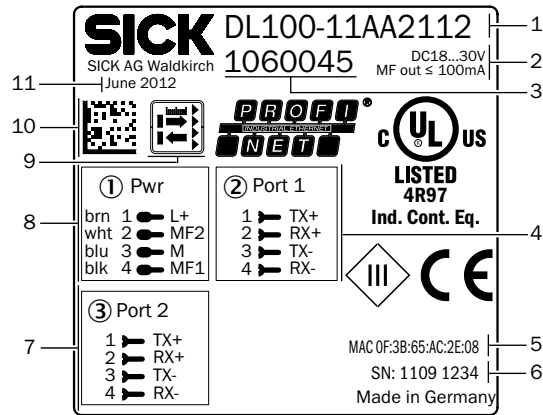

Fig. 2: Type Label

- 1 Type code → See page 94, chapter 14.2.
- 2 Supply voltage, multifunction output current
- 3 Device number
- 4 Assignment for female connector Port 1
- 5 MAC address
- 6 Serial number
- 7 Assignment for female connector Port 2
- 8 Assignment for supply voltage plug
- 9 Icon: Distance sensor reflector mode
- 10 Barcode
- 11 Production year and month

4 Setup and function

4.1 Setup

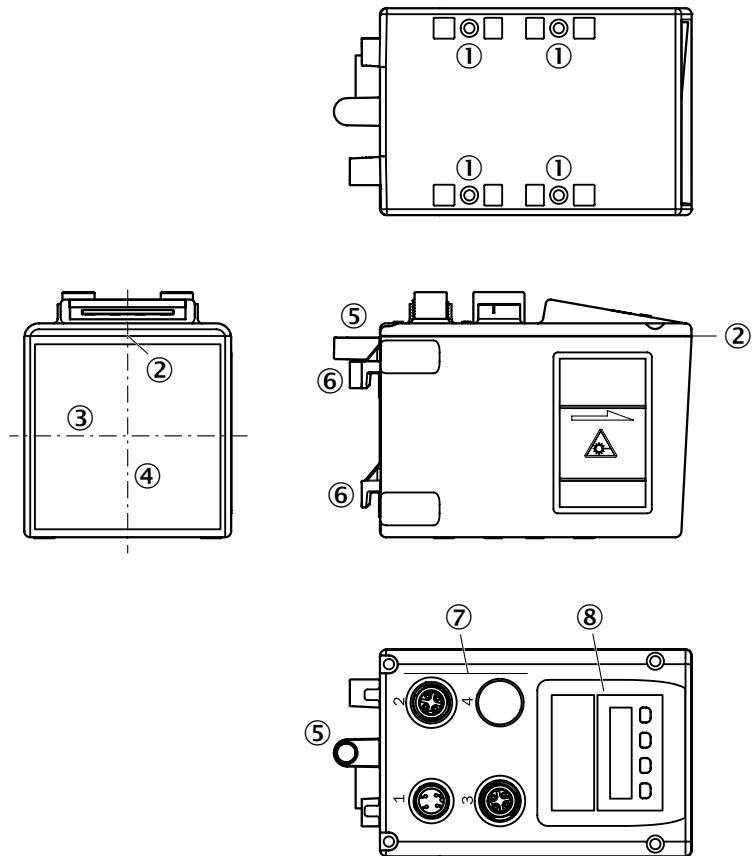

Fig. 3: Setup "distance measuring device DL100"

- 1 Threaded mounting hole M5
- 2 Device zero point
- 3 Optical axis sender
- 4 Optical axis receiver
- 5 Bore for knurled screw of the optional alignment bracket
- 6 Holder for optional alignment bracket
- 7 Electrical connection
- 8 Display and operating unit

Setup and function

4.2 Function

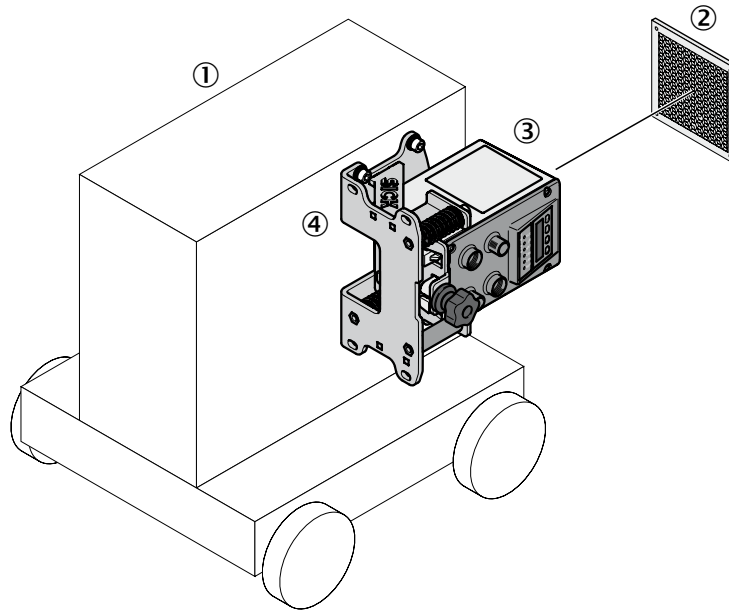

Fig. 4: Function "distance measuring device DL100"

- 1 Vehicle
- 2 Reflector
- 3 Distance measuring device DL100
- 4 Alignment bracket

The distance measuring device DL100 comprises optics, a sender/receiver unit and an evaluation unit. The sender emits the laser beam. The receiver receives light reflected by the reflector. The evaluation electrical unit determines the distance between sensor and reflector by time of flight measurement.

For measurement, either the reflector or the measuring device may move linearly along the laser beam.

The distance measuring device DL100 is equipped with two Ethernet interfaces. They serve communication via PROFINET IO and diagnosis and parameterization via SOPAS ET. The two interfaces have equal priorities and are internally connected to one switch.

The measured distance is transferred via the "PROFINET IO" interface and may be used, e.g. for the control unit or a position-control circuit.

4.3 Display and operating elements

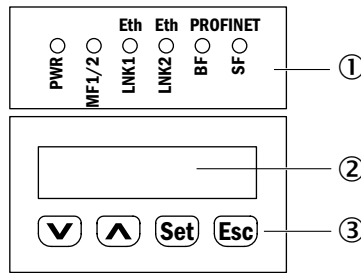

Fig. 5: Display and operating elements

- 1 LEDs
- 2 Display
- 3 Keys

LEDs

LED	Description
PWR	Display of operating status <ul style="list-style-type: none"> • LED off: No operation • LED green: Trouble-free operation • LED orange flashing: Warning (see warning status, upper level menu) • LED red flashing: Interference (see error status, menu on the top level) → Troubleshooting, see page 88, chapter 12.
MF1/2	The status for multi-function input/output MF1 and multi-function output MF2 is presented via an LED. → See page 20, Table 2.
LNK1	Ethernet <ul style="list-style-type: none"> • LED off: No Ethernet present • LED green: Ethernet present • LED orange flashing: Data transmission
LNK2	Ethernet <ul style="list-style-type: none"> • LED off: No Ethernet present • LED green: Ethernet present • LED orange flashing: Data transmission
BF	Interface PROFINET IO → See following table "LEDs BF and SF".
SF	Bus status → See following table "LEDs BF and SF".

Table 1: LEDs

Setup and function

LED MF1/2

LED MF1/2	MF1	MF2
Off	OFF	OFF
Blue	ON	OFF
Yellow	OFF	ON
White	ON	ON

Table 2: LED MF1/2

LEDs BF und SF

BF	SF	Beschreibung
Off	OFF	Connection OK.
Red	Red	Status after switching on. Bus interrupted Master (PLC) cannot be reached.
Flashing red	Red	Bus error → Troubleshooting, see page 89, chapter 12.1.

Table 3: LEDs BF and SF

Symbols for operating modes

The distance measuring device differentiates between the two operating modes "measured value display" and "menu operation".

Icon	Description
RUN	The icon RUN is displayed in the operating mode "measured value display". If there is an error and no measurement value can be determined, the icon RUN disappears.
MEN	The icon MEN is displayed in the operating mode "menu operation". The icon is also displayed when there is an error and no measurement value can be determined.

Table 4: Symbols for operating modes

Keys





Key	Description
	<ul style="list-style-type: none"> Select menu, parameters or options. Reduce value.
	<ul style="list-style-type: none"> Select menu, parameters or options. Increase value.
	<ul style="list-style-type: none"> Switch to the next lower menu level. Save parameter change. Confirm selection.
	<ul style="list-style-type: none"> Leave parameter without saving. Switch to the next higher menu level.

Table 5: Keys

4.4 Display

Measured value display

The measurement value is displayed by default:

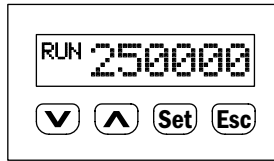

Fig. 6: Measured value display

Menu display



Fig. 7: Menu display



NOTE!

If a value or display has more than six characters, the characters are automatically displayed in sequence.

Transport and storage

5 Transport and storage

5.1 Transport

Improper transport

**ATTENTION!****Damage to the distance measuring device by improper transport!**

Improper transport may cause considerable property damage.

Therefore:

- Only have transport performed by trained workers.
 - When unloading and during internal transport, always proceed with the greatest care and caution.
 - Observe icons on the packaging.
 - Only remove packaging right before commencement of installation.
-

5.2 Transport inspection

Improper transport

Inspect the delivery for completeness and transport damage without delay upon receipt.

If there is any externally visible transport damage, proceed as follows:

- Do not accept the delivery, or only under reservation.
 - Note the scope of the damage on the transport documents or the delivery receipt of the transporter.
 - Initiate complaints.
-

**NOTE!**

Report every defect as soon as you recognize it. Damages claims can only be asserted within the applicable complaint periods.

5.3 Storage

Store the distance measuring device under the following conditions:

- Do not leave it outside.
- Store dry and dust-free.
- Do not expose to any aggressive media.
- Protect from solar irradiation.
- Avoid mechanical vibrations.
- Storage temperature: –40 to 75 °C
- Relative humidity: max. 95 %, non-condensing
- At storage exceeding 3 months, regularly inspect the general condition of all components and the packaging.

Mounting

6 Mounting

6.1 Mounting process

1. Determine mounting site under consideration of the mounting notes.
→ See following chapter.
2. Mount alignment bracket and distance measuring device.
→ See page 29, chapter 6.7.
3. Perform electrical connection
→ See page 32, chapter 7.
4. Align distance measuring device and reflector against each other.
→ See page 28, chapter 6.6
5. Align distance measuring device with the reflector using the alignment bracket fine adjustment. → See page 31, chapter 6.8.
6. Fasten alignment of the distance measuring device.
→ See page 31, chapter 6.8.

6.2 Mounting notes

Observe the following mounting notes for trouble-free operation:

- Comply with technical specifications like the measurement range.
→ See page 95, chapter 14.4.
- Use distance measuring device with optional heating in low ambient temperatures, e.g. in deep freeze storage.
- At higher temperatures, use the distance measuring device with optional cooling casing. → See page 103, chapter 15.4.
- Protect the distance measuring device from solar irradiation.
- To avoid condensation, do not expose the distance measuring device to any quick temperature changes.
- Observe the assembly notes for the reflector.
→ See page 24, chapter 6.2.
- Keep sufficient distance to other distance measuring devices.
→ See page 26, chapter 6.4.
- Keep sufficient distance to data transmission photoelectric switches.
→ See page 27, chapter 6.5.

6.3 Choose and mount reflector



NOTE!

→ For suitable reflectors and suitable reflective tape, see page 98, chapter 15.1

Reflector size

- Select the reflector size so that the light spot does still meet the reflector in case of vibrations.
- If the reflector is installed at a vehicle, a smaller reflector is typically sufficient.

Requirements

- Highly reflective surfaces close to the reflector can cause beam deflections or stray light and thus lead to incorrect measurements. Highly reflective surfaces may be, among others, shelf profiles, palettes wrapped with stretch foil and running rails.
- When mounting the distance measuring device in the horizontal axis of stacker crane, incline the reflector towards the ceiling, away from the rail (approx. 1° to 3°). → See following figure.
- When mounting in the vertical axis, incline away from the stacker crane's mast (approx. 1° to 3°). → See following figure.

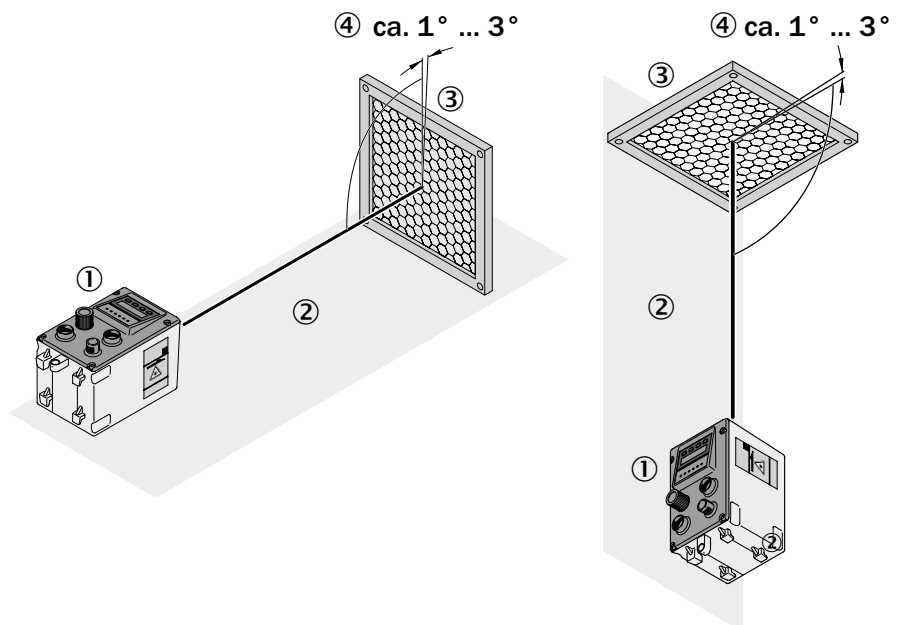

Fig. 8: Installing the reflector on highly reflective surfaces
Left: Installed in driving axis, installed at the right in the lifting axis

- 1 Distance measuring device
- 2 Highly reflective surface
- 3 Reflector
- 4 Inclination of approx. 1° to 3°

Mounting

6.4 Placement of multiple distance measuring device

Multiple distance measuring device If you want to mount several distance measuring devices, you have to consider a minimum distance between the distance measuring devices when mounting them. The minimum distance increases with the maximum scanning range of the distance measuring device.

Formula $a \geq 100 \text{ mm} + 0.01 \times s_{\text{max}} \text{ [mm]}$

- Example**
- Distance measuring device DL100–21xxx01
 - Measuring range: 0.15 ... 100 m
 - Maximum measuring distance 60 m
 - $s_{\text{max}} = 60 \text{ m}$

Calculation

$$a \geq 100 \text{ mm} + 0.01 \times 60000 \text{ mm} \rightarrow 100 \text{ mm} + 600 \text{ mm} \rightarrow 700 \text{ mm}$$

Result

$$a \geq 700 \text{ mm}$$

Light beams in the same direction

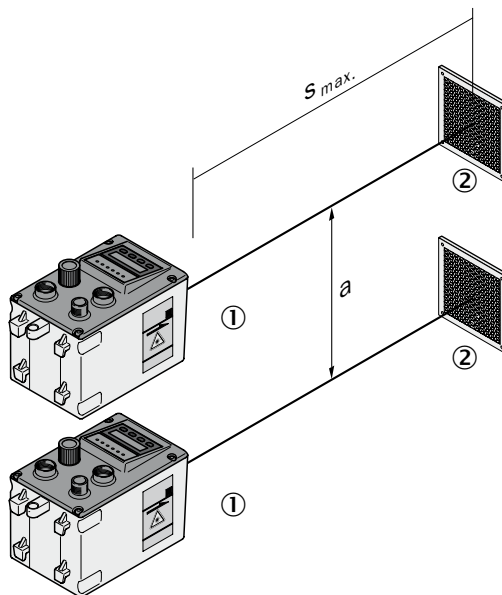

Fig. 9: Placement of two distance measuring devices with light beams in the same light direction.

- 1 Distance measuring device DL100
- 2 Reflector
- a Minimum distance
- s_{max} Maximum scanning range

Light beams in the opposite direction

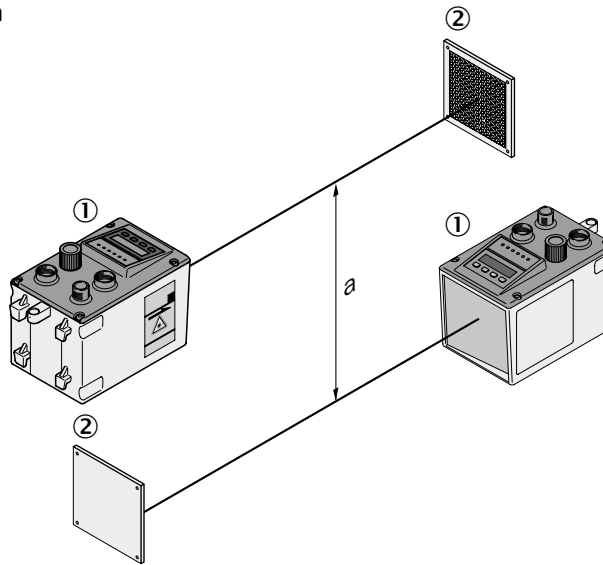

Fig. 10: Placement of two distance measuring devices with light beams in the opposite direction.

- 1 Distance measuring device DL100
- 2 Reflector
- a Minimum distance

6.5 Place the distance measuring device towards the adjacent data transmission photoelectric switch

When mounting with a data transmission photoelectric switch of the ISD300, ISD400-1xxx and ISD400-6xxx series, a beam separation of at least 100 mm must be complied with at all times. The maximum scanning range does not influence the minimum distance. For devices of the ISD400-7xxx (ISD400 Pro) serie other minimum distances apply. Refer to operating instructions “ISD400 Pro”.

Formula $a \geq 100 \text{ mm}$

Mounting

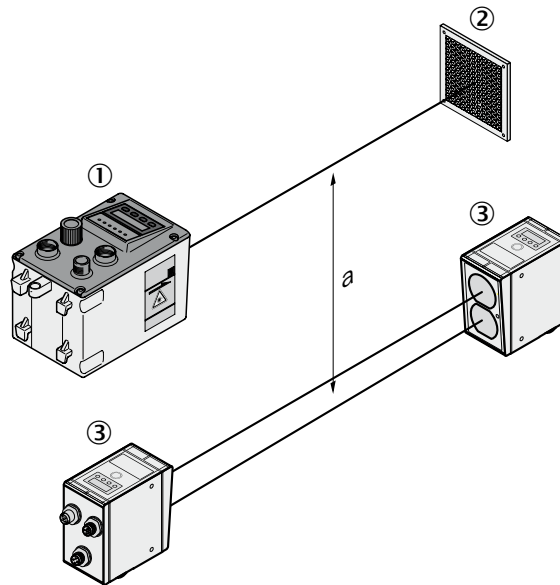

Fig. 11: Placement of the distance measuring device to the data transmission photoelectric switch ISD

- 1 Distance measuring device DL100
- 2 Reflector
- 3 Data transmission photoelectric switch ISD
- a Minimum distance

6.6 Align distance measuring device and reflector against each other

1. Move the distance measuring device and reflector close together.
2. Align the distance measuring device so that the light spot of the sensor hits the center of the reflector.
3. Increase the distance between the distance measuring device and the reflector. The sensor light spot must continue to hit the center of the reflector.
4. Check damping. The damping value must not exceed the value in the table.

Damping value

The following table shows the required damping values depending on the distance between the distance measuring device and the reflector. The values in the "rated level" column should not be undercut. When the measured damping value undercuts the value in the column "warning threshold", a warning is issued.

Distance [m]	Rated level [dB]	Warning threshold [dB]
<10	-30	-42
10	-30	-42
20	-42	-54
35	-54	-66
70	-66	-78
150 ¹⁾	-78	-90
300 ²⁾	-90	-102

1) For distance measuring devices with a measurement range of 0.15 ... 200 m or 0.15 ... 300 m

2) For distance measuring devices with a measurement range of 0.15 ...300 m

Table 6: Damping values

6.7 Mount alignment bracket and distance measuring device

The distance measuring device is mounted by the optional alignment bracket.

→ For dimensions and item number, see page 93, chapter 14.1.

Observe the following items:

- Mounting notes: → see page 24, chapter 6.2.
- The operation must be accessible.

Mounting

1. Mount alignment bracket across the four oblong holes. The alignment bracket is suitable for mounting to horizontal and vertical levels.

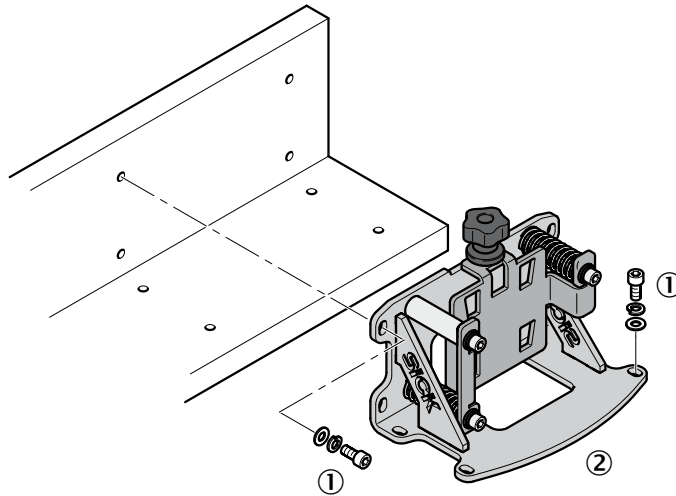

Fig. 12: Mount alignment bracket

- 1 Mounting screw M5
- 2 Alignment bracket

2. Turn out knurled screw until the distance measuring device can be inserted.
3. Move distance measuring device into the alignment bracket.

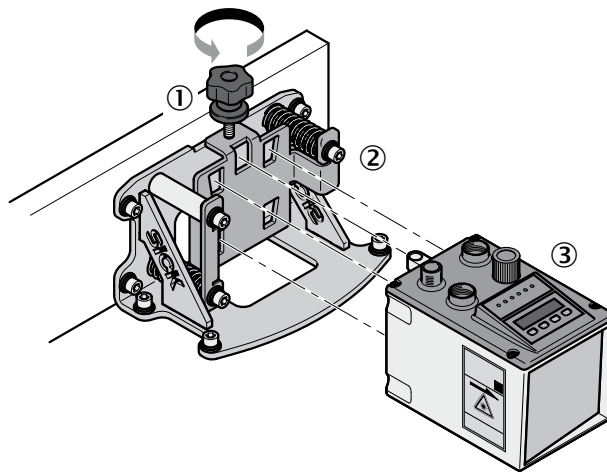

Fig. 13: Mount distance measuring device

- 1 Knurled screw
- 2 Alignment bracket
- 3 Distance measuring device

4. Attach distance measuring device via the knurled screw.

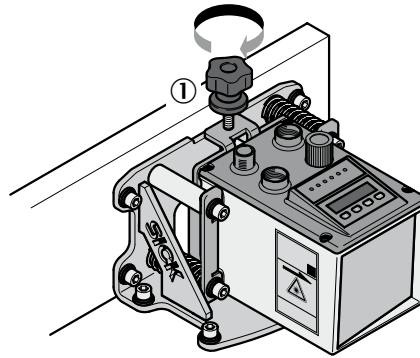

Fig. 14: Attach distance measuring device with the knurled screw

- 1 Knurled screw

6.8 Distance measuring device above alignment bracket

Align the distance measuring device with the alignment bracket according to the following figures. The sensor light spot must hit the center of the reflector.

Alignment in X-direction

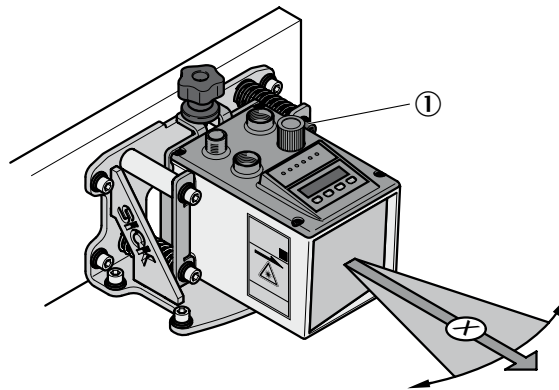

Fig. 15: Align distance measuring device in X-direction using the alignment bracket

- 1 Set screw to align the distance measuring device in X-direction

Electrical connection

Alignment in Y-direction

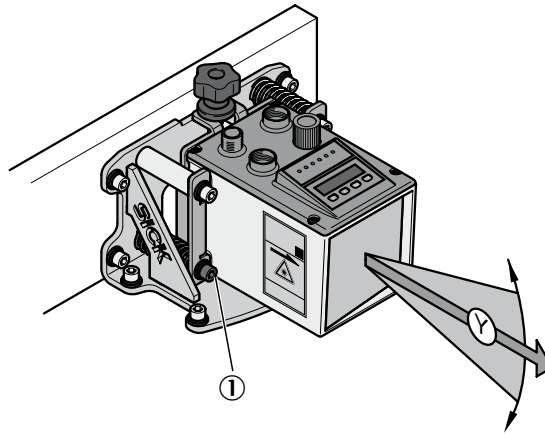

Fig. 16: Align distance measuring device in Y-direction using the alignment bracket

- 1 Set screw to align the distance measuring device in Y-direction

7 Electrical connection

7.1 Safety

Wrong supply voltage



ATTENTION!

Device damage from wrong supply voltage!

Incorrect supply voltage may cause damage to the device.

Therefore:

- Only operate the distance measuring device with a protected low voltage and secure electrical insulation of protection class III.

Work under voltage



ATTENTION!

Device damage or unintended operation by work under voltage!

Working under voltage may cause unintended operation.

Therefore:

- Only perform wiring work in the powered down condition.
- Line connections must only be established and disconnected with the supply voltage switched off.



WARNING!

Risk of damage to the device resulting from a non-grounded supply voltage or equipotential bonding currents!

A non-grounded supply voltage or potential differences between the supply voltage GND and the distance measuring device housing may result in the device sustaining damage.

For this reason:

- Only operate with a grounded supply voltage.
 - Ensure low-impedance and current-carrying equipotential bonding.
-

7.2 Wiring Notes



ATTENTION!

Fault from improper wiring!

Improper wiring may cause malfunctions in operation.

Therefore:

- Only use shielded cables with twisted pair wires.
 - Observe wiring notes.
-



NOTE!

→ *Ready-made cables, see page 101, chapter 15.2.*

Electrical connection

All electrical connections of the distance measuring device DL100 are M12 round plugs.

The connection plugs of the distance measuring device are compatible to the SpeedCon™-quick connections and standard-M12 screw connections.

The PROFINET IO cable shields are connected to each other via the PROFINET IO plugs.

Protection class IP65 is only achieved with screwed plug connectors or cover caps.

Observe the following notes for wiring:

- A proper and complete shielding concept is required for interference-free function.
- The cable shield must be applied on either side in the control cabinet and the measuring device. The cable shield of the ready-made cables is connected to the knurled nut and thus the measuring device casing.
- Connect the cable shield in the control cabinet with the operating ground on a large cross-section.
- Potential balancing currents through the cable shield must be prevented by suitable measures.
- Do not install the cable in parallel to the other lines, in particular not devices with a high electromagnetic interference, such as frequency converters.

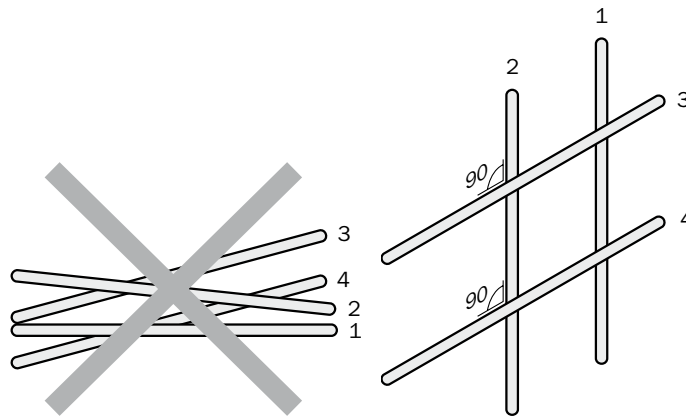

Fig. 17: Cross lines at a right angle

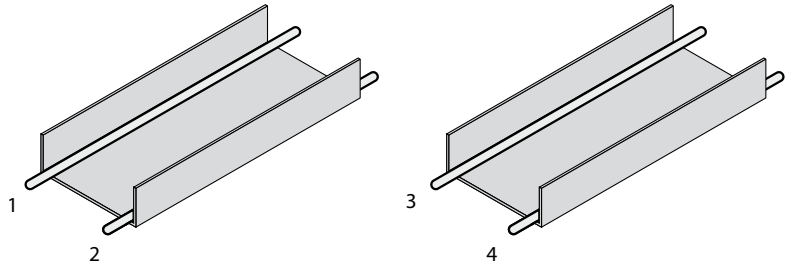

Fig. 18: Ideal placement –
Place lines in different cable channels

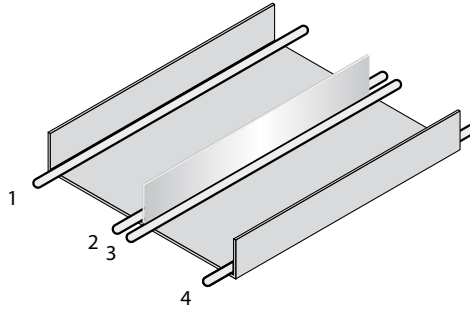

Fig. 19: Alternative installation – separate lines by metallic separation

- 1 Cables very sensitive to interference like analog measuring lines
- 2 Cables sensitive to interference, such as sensor cables, communication signals, bus signals
- 3 Cables that are sources of interference, such as control cables for inductive loads, motor brakes
- 4 Cables that are strong sources of interference, such as frequency converter output cables, supply to welding plants; power cables

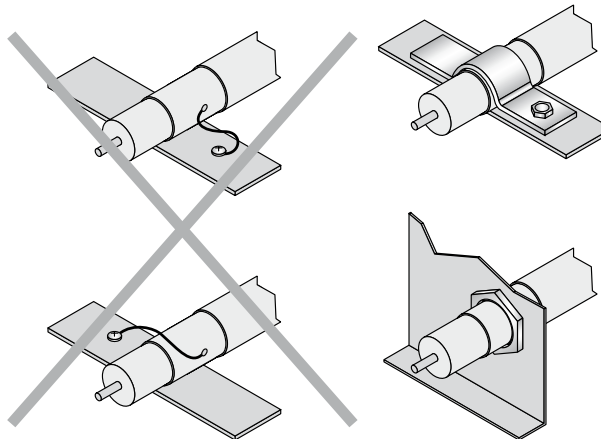

Fig. 20: Briefly connect shield with a large area - earth both sides

Electrical connection

7.3 Electrically connect distance measuring device



NOTE!

The distance measuring device has the connection diagram and information on the inputs and outputs on the type sign.

1. Ensure that there is no voltage applied.
2. Connect the measuring device according to the connection diagram.
 - Connection 1 "Supply voltage"
 - Connection 2 "Ethernet Port 1"
 - Connection 3 "Ethernet Port 2"

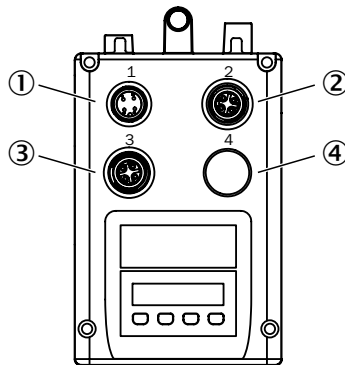

Fig. 21: Position of the electrical connections

- 1 Plug for the supply voltage
- 2 Female connector for Ethernet Port 1
- 3 Female connector for Ethernet Port 2
- 4 not connected

7.4 Connection diagrams

7.4.1 Connection diagram supply voltage

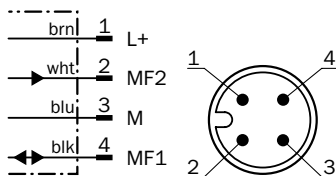

Fig. 22: Connection diagram supply voltage, plug M12, 4-pin, A-coded

Contact	Marking	Wire color	Description
1	L+	brown	Supply voltage: +18 ... +30 V DC
2	MF2	white	Multifunction output MF2
3	M	blue	Supply voltage: 0 V
4	MF1	black	Multifunctional input and output MF1

Table 7: Description plug supply voltage

7.4.2 Connection diagram Port 1 and Port 2 (Ethernet/PROFINET IO)

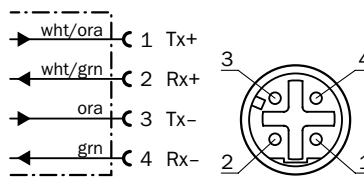

Fig. 23: Connection diagram Port 1 and Port 2, plug M12, 4-pin, D-coded

Contact	Marking	Wire color	Description
1	Tx+	white/ orange	Send data signal, not inverted
2	Rx+	white/green	Receive data signal, not inverted
3	Tx-	orange	Send data signal, inverted
4	Rx-	green	Receive data signal, inverted

Table 8: Description socket Port 1 and Port 2

8 Operation at the measuring device

Damage to operation



ATTENTION!

Damage to the buttons by incorrect handling!

Incorrect handling of the keys may damage the keys. Operation is made difficult or impossible by this.

Therefore:

- Only operate keys with your fingers or a pointer.
- Do not operate buttons with pointed or hard objects.

Operation at the measuring device

**NOTE!**

Once the device is integrated into a PROFINET network, the parameters entered in the measuring device are overwritten.

8.1 Measured value display

Once the measuring device is supplied with voltage, the display will indicate the current measurement value.

8.2 Choose parameter

Choose a menu, a parameter or an option using the keys **Set** and **▼**. The menu path is indicated in the respective chapter.

→ For the entire menu structure, see page 104, chapter 16.

8.3 Choose option

1. Use the keys **Set** and **▼** to select the desired parameter.
2. Use the key **▼** or **▲** to select the desired option.
3. Perform one of the following steps:
 - Push the key **Set** to save the changes.
 - Push the key **Esc** to cancel the process. The parameter name is displayed again.
4. Perform one of the following steps to return to the measured value display:
 - Push the key **Esc** until the measured value is displayed again.
 - Wait for approx. 2 minutes. The display automatically switches back to measured value display without operation of a key. Any settings made are also saved.

8.4 Change value

1. Use the keys **Set** and **▼** to select the desired parameter.
2. Push the key **Set**. The current value of the parameter is displayed. The first figure on the left flashes.
3. Push the key **▲** to increase the figure. Push the key **▼** to reduce the figure.
4. Push the key **Set** to save the figure entered. The next figure flashes. Push the key **Esc** to cancel the process.
5. Repeat the steps 3 and 4 until the last figure is saved. The parameter name is displayed.
6. Push the key **Esc** until the measured value is displayed again. Alternatively, you may also wait for a few minutes. The display automatically switches back to measured value display without operation of a key.

8.5 Parameter description

8.5.1 Main menu

The measurement value is displayed by default:

Use the **▼**-key to get from the measured value display to the display "Level Bargraph". Use the keys **▼** and **▲** to browse within the main menu.

Push the **Set**-key for at least 2 seconds to get to the "Menu".

Display	Description
Measurement value	Measurement value display in mm
Level Bargraph	Level display (damping value) as bargraph
Level numeric	Level display (damping value) as numeric value → Also see page 29, Table 6.
Temperature	Display of indoor temperature of the measuring device
Operating hours counter	Operating hours display
Warnings	Display of the pending warnings. When a warning is pending, the LED PWR flashes orange. When no warnings are pending, no warnings are displayed. → Also see page 89, chapter 12.2, list of possible warnings.
Error	Display of the pending warnings. When an error is pending, the LED PWR flashes red. When no errors are pending, no errors are displayed. → Also see page 90, chapter 12.3, list of possible errors.

Table 9: Main menu

Operation at the measuring device

8.5.2 Menu "SwVers"

The menu "SwVers" shows all information on the software.

You can get to the menu "SwVers" via the menu path:

Main menu → **Set** → Menu → **▼** → SwVers

Push the **Set**-key so that the parameter "App-uC" is displayed.

Use the keys **▼** and **▲** to browse within the menu. Push the **Set**-key to display the respective parameter value.

Parameter	Description
App-uC	Display of the version of the application processor
FPGA	Display of the version of the Field Programmable Gate Array
Com-uC	Display of the version of the communication processor

Table 10: Menu "SwVers"

8.5.3 Menu "HwVers"

The menu "HwVers" shows all information on the hardware.

You can get to the menu "HwVers" via the menu path:

Main menu → **Set** → Menu → **▼** → SwVers → **▼** → HwVers

Push the **Set**-key so that the parameter "HwVers" is displayed.

Parameter	Description
HwVers	Version number display

Table 11: Menu "HwVers"

8.5.4 Menu "Profin"

Use the menu "Profin" to set the bus address.

You can get to the menu "Profin" via the menu path:

Main menu → **Set** → Menu → **Set** → Profin

Push the **Set**-key so that the parameter "StName" is displayed.

Use the keys **▼** and **▲** to browse within the menu. Push the **Set**-key to display the respective parameter value.

Parameter	Description
StName	Display station name Factory setting <ul style="list-style-type: none"> • dl100
ResDst	Choose resolution for the output value "Distance" via the digital data interface. The measurement value is multiplied with the resolution. The parameter does not influence the measurement value displayed. Prerequisite The parameter is only displayed if the option "Yes" is selected for the parameter "more". Options <ul style="list-style-type: none"> • 0.1 • 0.125 • 1.0 • 10.0 • 100.0 Factory setting <ul style="list-style-type: none"> • 0.1 mm

Menu "Profin" (continued)

Options	Description
ResSpd	Choose resolution for the output value "Speed" via the digital data interface. The measurement value is multiplied with the resolution. The parameter does not influence the measurement value displayed. Prerequisite <ul style="list-style-type: none"> • The parameter is only displayed if the option "Yes" is selected for the parameter "more". Options <ul style="list-style-type: none"> • 0.1 • 1.0 • 10.0 • 100.0 Factory setting <ul style="list-style-type: none"> • 0.1 mm/s

Table 12: Menu "Profin"

Operation at the measuring device

8.5.5 Menu "more"

Use the menu "More" to activate and deactivate the expanded menu view.

You can get to the menu "More" via the menu path:

Main menu → **Set** → Menu → **Set** → Profin → **▼** → more

Push the **Set**-key. The currently set option is displayed here.

Options	Description
Yes / No	Activate and deactivate expanded menu view. Options <ul style="list-style-type: none"> • Yes • No Factory setting <ul style="list-style-type: none"> • No

Table 13: Menu "More"

8.5.6 Menu "MFx On"

Use this menu to activate and deactivate the multifunction input/output MF1 and the multifunction output MF2.

You can get to the menu "MFx On" via the menu path:

Main menu → **Set** → Menu → **Set** → Profin → **▼** → more → **▼** → MFx On.

Push the **Set**-key. The currently set option is displayed here.

Requirements for the display

- Menu "more": Option "Yes"

Options	Description
Enable / Disable	Activate or deactivate multifunction input/output MF1 and multifunction output MF2 Options <ul style="list-style-type: none"> • Enable: Multifunction input/output MF1 and multifunction output MF2 are activated. • Disable: Multifunction input/output MF1 and multifunction output MF2 are deactivated. Factory setting <ul style="list-style-type: none"> • Enable

Table 14: Menu "MFx On"

8.5.7 Menu "MF1"

This menu and the associated submenus can be used to set parameters for the multifunction input/output MF1.

You can get to the menu "MF1" via the menu path:

Main menu → **Set** → Menu → **Set** → Profin → **▼** → more → **▼** → MFx On → **▼** → MF1.

Push the **Set**-key so that the parameter "ActSta" is displayed.

Use the keys **▼** and **▲** to browse within the menu. Push the **Set**-key to display the respective parameter value.

Requirements for the display

- Menu "more": Option "Yes"
- Menu "MFx On": Option "Enable"

Parameter	Description
ActSta	<p>Select level or flank of the multifunction input/output MF1.</p> <p>Options</p> <ul style="list-style-type: none"> • ActLow: LOW-level at active output (normally closed/NC) or activation of the input at dropping flank • ActHi: HIGH-level at active output (normally open/NO) or activation of the input at rising flank <p>Factory setting</p> <ul style="list-style-type: none"> • ActLow
Functn	<p>Select function for the multifunction input/output. Depending on the selection, the corresponding submenu is displayed.</p> <p>Options</p> <ul style="list-style-type: none"> • Dist: MF1 is used as distance switching output. • Speed: MF1 is used as speed switching output. • Srvce: MF1 is used as service output. • LsrOff: MF1 is used as input to deactivate the laser. • Preset: MF1 is used as input for activation of the preset (overwriting the offset). Offset = Preset value - current measured value. <p>Factory setting</p> <ul style="list-style-type: none"> • Dist
Dist / Speed Srvce / LsrOff / Preset	<p>Depending on the selection for the parameter "Functn", the corresponding submenu is displayed. For parameter description, see the respective table.</p> <p>No further submenu is displayed for the option "LsrOff". When the multifunction input MF1 is active, the laser is switched off.</p>
Count	<p>Counts the switching events of the multifunction input/output. The counter is reset by deactivation and activation of the distance measuring device.</p>

Table 15: Menu "MF1"

Operation at the measuring device

8.5.8 Submenu "MF1 – Dist"

This submenu is used to parameterize the multifunction output MF1 as distance switching output.

You can get to the menu "Dist" via the menu path:

Main menu → Set → Menu → Set → Profin → → more → → MFx On → → MF1 → Set → Actsta → → Functn → → Dist

Requirements for the display

- Menu "more": Option "Yes"
- Menu "MFx On": Option "Enable"
- Parameter "Functn": Option "Dist"

Parameter	Description
Limit	Set distance-dependent switching threshold
Hysteresis	Set Hysteresis for the switching threshold

Table 16: Submenu "MF1 – Dist"

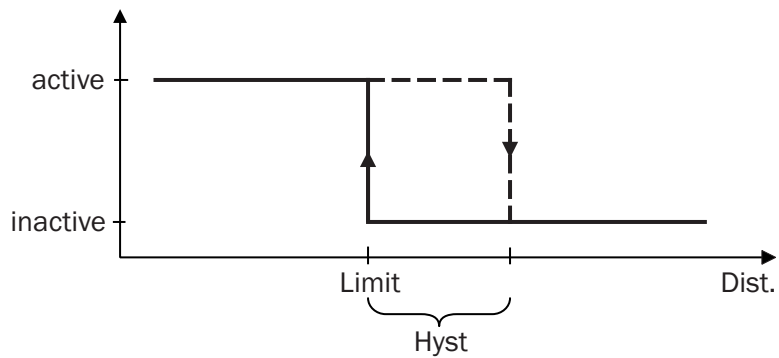

Fig. 24: Displaying the function "Dist."

Limit Distance-dependent switching threshold

Hyst: Switching threshold hysteresis

Dist: Measured distance

8.5.9 Submenu "MF1 – Speed"

This submenu is used to parameterize the multifunction output MF1 as speed output.

You can get to the menu "Speed" via the menu path:

Main menu → **Set** → Menu → **Set** → Profin → **▼** → more → **▼** → MFx On → **▼** → MF1 → **Set** → Actsta → **▼** → Functn → **▼** → Speed

Requirements for the display

- Menu "more": Option "Yes"
- Menu "MFx On": Option "Enable"
- Parameter "Functn": Option "Speed"

Parameter	Description
Limit	<p>Set speed for the switching threshold The switching output is activated when the current speed exceeds the set speed. The switching hysteresis is set firmly to ± 0.1m/s.</p> <p>Adjustment range</p> <p>Range 0.0 ... 9.9 m/s</p> <p>Factory setting</p> <ul style="list-style-type: none"> • 0 [mm]
Sign	<p>Choose the travel direction to be monitored.</p> <p>Options</p> <ul style="list-style-type: none"> • + / -: Once the set speed is exceeded in one direction, the switching output is activated. • +: Once the set speed is exceeded with increasing distance, the switching output is activated. • -: Once the set speed is exceeded with decreasing distance, the switching output is activated. <p>Factory setting</p> <ul style="list-style-type: none"> • + / -

Table 17: Submenu "MF1 – Speed"

Operation at the measuring device

8.5.10 Submenu "MF1 – Srvce"

This submenu is used to parameterize the multifunction output MF1 as service output. You may activate (on) or deactivate (off) several options.

You can get to the menu "Srvce" via the menu path:

Main menu → → Menu → → Profin → → more → → MFx On → → MF1 → → Actsta → → Functn → → Srvce

Requirements for the display

- Menu "more": Option "Yes"
- Menu "MFx On": Option "Enable"
- Parameter "Functn": Option "Srvce"

Parameter	Description
WrnLsr	<p>Activating and deactivating warning messages when the measuring device must be replaced soon because the laser ages.</p> <p>Options</p> <ul style="list-style-type: none"> • On • Off <p>Factory setting</p> <ul style="list-style-type: none"> • On
WrnLvl	<p>Activate or deactivate warning messages when the damping value is undercut, e.g. at contamination.</p> <p>Options</p> <ul style="list-style-type: none"> • On • Off <p>Factory setting</p> <ul style="list-style-type: none"> • On
WrnTemp	<p>Activate or deactivate warning message when the inner temperature of the measuring device is outside of the permissible thresholds.</p> <p>Options</p> <ul style="list-style-type: none"> • On • Off <p>Factory setting</p> <ul style="list-style-type: none"> • On
WrnPlb	<p>Activate or deactivate warning when the measurement value is not plausible. Possible reasons may be incorrect measurements, interruption of the light beam, optical interferences or electrical interferences.</p> <p>Options</p> <ul style="list-style-type: none"> • On • Off <p>Factory setting</p> <ul style="list-style-type: none"> • On

**Submenu "MF1 – Srvce"
(continued)**

Parameter	Description
NotRdy	<p>Activate or deactivate warning when the laser is not ready for operation. Possible causes may be hardware faults or the laser being switched off. This warning message is also output during initialization.</p> <p>Options</p> <ul style="list-style-type: none"> • On • Off <p>Factory setting</p> <ul style="list-style-type: none"> • On
Heat	<p>Activate or deactivate warning when the heating is switched on. This parameter is only displayed for measuring devices with the option "Heating".</p> <p>Options</p> <ul style="list-style-type: none"> • On • Off <p>Factory setting</p> <ul style="list-style-type: none"> • On

Table 18: Submenu "MF1 – Srvce"

8.5.11 Submenu "Preset" – move to initialization position

Description

The function "Preset" permits automation of initialization of shelf supply devices and other rail-bound vehicles during maintenance, commissioning or exchange.

During initialization, the desired output value is set in a defined position (initialization position) (Preset).

This submenu is used to parameterize the multifunction input MF1 as "Preset function".



NOTE!

When activating the "Preset", the measured value output of the distance measuring device is not available for a short time. We recommend performing the "Preset" in standstill or at very low speeds. The maximum activation time is typically at 10000 cycles.

Operation at the measuring device

Submenu “MF1 – Preset”

Main menu → **Set** → Menu → **Set** → Profin → **▼** → more → **▼** → MFx On → **▼** → MF1 → **Set** → Actsta → **▼** → Functn → **▼** → Preset

Requirements for the display

- Menu "More" Option "On"
- Menu "MFx On": Option "Enable"
- Parameter "Functn": Option "Preset"

Parameter	Description
sPreset	<p>The preset serves as initialization value. When the multifunction input MF1 is activated, the preset is used.</p> <p>Adjustment range</p> <ul style="list-style-type: none"> • -300000 ... + 300000 <p>Since the display only has six digits, you may only enter negative values up to "-99999" in the display.</p> <p>Factory setting</p> <ul style="list-style-type: none"> • 10

Table 19: Submenu "MF1 – Preset"

Set Preset

1. Select the function "Preset" for the multifunction input MF1
2. Enter the parameter "Preset" for the desired initialization value.
3. Move the vehicle to the initialization position.
4. Activate the multifunction input MF1, e.g. via a proximity initiator, photo-electric sensor or switch.
5. The output value of the distance measuring device corresponds to the value set for "Preset" at the initialization position.

8.5.12 Menu "MF2"

This menu and the associated submenus can be used to set parameters for the multifunction output MF2.

You can get to the menu "MF2" via the menu path:

Main menu → **Set** → Menu → **Set** → Profib → **▼** → more → **▼** → MFx On → **▼** → MF1 → **▼** → MF2

Push the **Set** key so that the parameter "ActSta" is displayed.

Use the keys **▼** and **▲** to browse within the menu. Push the **Set** key to display the respective parameter value.

Requirements for the display

- Menu "more": Option "Yes"
- Menu "MFx On": Option "Enable"

Parameter	Description
ActSta	Select multifunction output level MF2. Options <ul style="list-style-type: none"> • ActLow: LOW-level at active output (opener/NC) • ActHi: HIGH-level at active output (closer/NO) Factory setting <ul style="list-style-type: none"> • ActLow
Functn	Select function for the multifunction output. Depending on the selection, the corresponding submenu is displayed. Options <ul style="list-style-type: none"> • Dist • Srvce • Speed Factory setting <ul style="list-style-type: none"> • Dist
Dist / Srvce / Speed	Depending on the selection for the parameter "Functn", the corresponding submenu is displayed. For parameter description, see the respective table.
Count	No further submenu is displayed for the option "LsrOff". When the multifunction input MF1 is active, the laser is switched off.

Table 20: Menu "MF2"

Submenu "MF2 – Srvce"

This submenu corresponds to the submenu "Srvce" in the menu "MF1".
→ Also see page 47, Table 18.

Submenu "MF2 – Dist"

This submenu corresponds to the submenu "Dist" in the menu "MF1".
→ Also see page 44, Table 16.

Submenu "MF2 – Speed"

This submenu corresponds to the submenu "Speed" in the menu "MF1".
→ Also see page 45, Table 17.

Operation at the measuring device

8.5.13 Menu "Offset"

Set an offset via this menu.

You can get to the menu "Offset" via the menu path:
 Main menu → **Set** → Menu → **Set** → Profib → **▼** → more → **▼** →
 MFx On → **▼** → (MF1 → **▼** → MF2 → **▼** →) Offset

Push the **Set** key. The currently set offset is displayed here.

Requirements for the display

- Menu "more": Option "Yes"

Value	Description
Offset	Specify offset. The offset is added to the internally determined measurement value. The offset affects all outputs and the display indication. When the "Preset" function is activated, the offset is over-written by triggering of the preset input. Adjustment range <ul style="list-style-type: none"> • -300000 ... +300.000 mm Factory setting <ul style="list-style-type: none"> • 0 [mm]

Table 21: Menu "Offset"

8.5.14 Menu "SpecFu"

Set special functions via this menu.

You can get to the menu "SpecFu" via the menu path:
 Main menu → **Set** → Menu → **Set** → Profin → **▼** → more → **▼** →
 MFx On → **▼** → (MF1 → **▼** → MF2 → **▼** →) Offset → **▼** → SpecFu

Push the **Set** key so that the parameter "AvgDst" is displayed.

Use the keys **▼** and **▲** to browse within the menu.

Requirements for the display

- Menu "more": Option "Yes"

Parameter	Description
AvgDst	Select filter depth for the distance values. Options <ul style="list-style-type: none"> • Medium • Slow • Fast Factory setting <ul style="list-style-type: none"> • Medium <i>Note: Medium and Slow use the same averaging depth.</i>

**Menu “SpecFu”
(continued)**

Parameter	Description
AvgSpd	<p>Select filter depth for the speed values.</p> <p>Options</p> <ul style="list-style-type: none"> • Medium • Slow • Fast <p>Factory setting</p> <ul style="list-style-type: none"> • Medium <p><i>Note: Medium and Slow use the same averaging depth.</i></p>
ErrRej	<p>Select time for error suppression. During this time, the old measurement value is output. When there still is no valid measurement value after the time selected for the parameter "ErrRej", the value "0" is output.</p> <p>Options</p> <ul style="list-style-type: none"> • 200ms: Error/warning is indicted when the error is present for longer than 200 ms. • 50ms: Error/warning is indicted when the error is present for longer than 50 ms. • Off Error/warning is indicated at once, without delay. <p>Factory setting</p> <ul style="list-style-type: none"> • 200ms
Heat	<p>Requirements for the display</p> <ul style="list-style-type: none"> • Only for versions with heating DL100-xxHxxxx <p>This menu is used to set the temperature at which the heating is to activate. The hysteresis is set firmly to 2 K.</p> <p>Adjustment range</p> <ul style="list-style-type: none"> • -10 ... +40 °C <p>Factory setting</p> <ul style="list-style-type: none"> • -10 °C
Reset	Perform reset → see page 52, chapter 8.6.

Table 22: Menu “SpecFu”

Operation at the measuring device

8.6 Perform reset

1. Select the parameter "Reset" in the menu "SpecFu".
→ See page 50, chapter
2. Push the key **Set**.
3. The safety request "Sure?" is displayed.
4. Push the button **Set** to reset the measuring device to the delivery state.
Push the key **Esc** to cancel the process.

9 Operation via Ethernet (Ethernet interface)

The distance measuring device DL100 is equipped with two Ethernet interfaces. They serve communication via PROFINET IO and diagnosis and parameterization via SOPAS ET. The two interfaces have equal priorities and are internally connected to one switch.



NOTE!

The configuration program SOPAS ET can be downloaded from "www.sick.com".



NOTE!

Parameters configured by Ethernet (SOPAS ET) are overwritten with the PROFINET IO parameters once the device is integrated into a PROFINET network.

9.1 IP-network configuration

IP-network configuration – delivery configuration

The distance measuring device is delivered with the following IP-network configuration:

- IP address: 192.168.100.236
- IP network mask: 255.255.255.0
- Standard gateway: 0.0.0.0

Invalid IP network configuration

If the system detects an invalid IP network configuration then the delivery-state configuration is used instead.

9.2 Ethernet parameter list

9.2.1 Device information

Field "Device information"

Parameter	Description
Device type	Display of the device type Read/Write access • Read only
Serial number	Display of the device's serial number Read/Write access • Read only

Table 23: Page "Device information" – field "Device information"

Operation via Ethernet (Ethernet interface)

Field "Product code"

Parameter	Description
Product code	Display of the product code Read/Write access <ul style="list-style-type: none"> • Read only

Table 24: Page "Device information" – field "Product code"

Field "Software Versions"

Parameter	Description
Application controller	Display of the version of the application processor Read/Write access <ul style="list-style-type: none"> • Read only
Communications controller	Indication of the version of the communication processor Read/Write access <ul style="list-style-type: none"> • Read only
FPGA	Display of the version of the Field Programmable Gate Array Read/Write access <ul style="list-style-type: none"> • Read only

Table 25: Page "Device information" – field "Software version"

Field "Hardware Version"

Parameter	Description
Hardware Version	Displaying the hardware version Read/Write access <ul style="list-style-type: none"> • Read only

Table 26: Page "Device information" – field "Hardware version"

9.2.2 User information



NOTE!

Changes on the page "User information" only take permanent effect if they are stored via the button "Storage" in the field "Store user information".

Field "Device name"

Parameter	Description
Name	Enter optional device name for device identification. Read/Write access <ul style="list-style-type: none"> • Read and write Factory setting <ul style="list-style-type: none"> • Empty

Table 27: Page "User information" – field "Device name"

Operation via Ethernet (Ethernet interface)

Field "User information"

Parameter	Description
User information 1	Enter optional user information Read/Write access <ul style="list-style-type: none">• Read and write Factory setting <ul style="list-style-type: none">• Empty
User information 2	→ See parameter "User input 1".
User information 2	→ See parameter "User input 1".

Table 28: Page "Device information" – field "User information"

Field "Store user information"

Parameter	Description
Storage	You may only enter user information at the user level "Maintenance". This requires the password "esick". Read/Write access <ul style="list-style-type: none">• Write only

Table 29: Page "User information" – field "Store user information"

9.2.3 Measurement values

Field "Distance value"

Parameter	Description
X-Scale	Enter X-axis for graphic display of the distance value. Read/Write access <ul style="list-style-type: none">• Read and write Unit <ul style="list-style-type: none">• s
Y min / Y max	Enter minimum and maximum value for the Y-axis. Read/Write access <ul style="list-style-type: none">• Read and write Unit <ul style="list-style-type: none">• m
Auto-Scale Y	Click the button "Auto-Scale Y" to adjust the display to the current measurement values. Read/Write access <ul style="list-style-type: none">• Read and write Unit <ul style="list-style-type: none">• m

Table 30: Page "Measured data" – field "Distance value"

Operation via Ethernet (Ethernet interface)

Field "Measurement values"

Parameter	Description
Distance	Measurement value "Distance" after filter, corrections and offset Read/Write access • Read only Unit • m
Velocity	Measurement value "Speed" Read/Write access • Read only Unit • m/s
Acceleration	Measurement value "Acceleration" Read/Write access • Read only Unit • m/s ²

Table 31: Page "Measured data" – field "Measurement values"

9.2.4 Diagnostic data

Field	Description
Device state	Display device status: ready for operation, warning(s) active, error active, laser activated, MF1 active and MF2 active Read/Write access • Read only
Device warning	Display of current warnings: Laser, temperature, level and plausibility Read/Write access • Read only
Device error	Display of current errors: Laser, temperature, level and plausibility Read/Write access • Read only
Level	Display of the current reception level (damping value) Read/Write access • Read only

Operation via Ethernet (Ethernet interface)

Page "Measurement values" (continued)

Field	Description
Temperature	Display of current internal device temperature Read/Write access <ul style="list-style-type: none"> • Read only Unit <ul style="list-style-type: none"> • °C
Operating hours	Display of current operating hours Read/Write access <ul style="list-style-type: none"> • Read only Unit <ul style="list-style-type: none"> • h

Table 32: Page "Diagnostic data"

9.2.5 Parameter settings



NOTE!

Parameter changes only enter into permanent effect if they are saved via the button "Storage".

Field "General settings"

Parameter	Description
Distance offset	Specify offset value for the distance measurement value. Read/Write access <ul style="list-style-type: none"> • Read and write Input value <ul style="list-style-type: none"> • -300000 ... 300000 Unit <ul style="list-style-type: none"> • mm Factory setting <ul style="list-style-type: none"> • 0
Preset	Specify present value for the distance measurement value. Read/Write access <ul style="list-style-type: none"> • Read and write Input value <ul style="list-style-type: none"> • -300000 ... 300000 Unit <ul style="list-style-type: none"> • mm Factory setting <ul style="list-style-type: none"> • 0

Table 33: Page "Parameter settings" – field "General settings"

Operation via Ethernet (Ethernet interface)

Field "Measurement value resolution"

Parameter	Description
Distance resolution	<p>Choose resolution for the output value "Distance". The measurement value is multiplied with the resolution. The parameter does not influence the measurement value displayed.</p> <p>Read/Write access</p> <ul style="list-style-type: none"> • Read and write <p>Input value</p> <ul style="list-style-type: none"> • 0: 0.1 / 1: 0.125 / 2: 1.0 / 3: 10.0 / 4: 100.0 <p>Factory setting</p> <ul style="list-style-type: none"> • 0.1 mm
Resolution speed	<p>Choose resolution for the output value "Speed". The measurement value is multiplied with the resolution. The parameter does not influence the measurement value displayed.</p> <p>Read/Write access</p> <ul style="list-style-type: none"> • Read and write <p>Input value</p> <ul style="list-style-type: none"> • 0: 0.1 / 1: 1.0 / 2: 10.0 / 3: 100.0 <p>Factory setting</p> <ul style="list-style-type: none"> • 1 mm/s

Table 34: Page "Parameter settings" – field "Measured value resolution"

Field "PROFINET IO configuration"

Parameter	Description
StName	<p>Display station name</p> <p>Read/Write access</p> <ul style="list-style-type: none"> • Read only <p>Factory setting</p> <ul style="list-style-type: none"> • dl100

Table 35: Page "Parameter settings" – field "PROFINET IO configuration"

Field "MF1/MF2 activation"

Parameter	Description
MF activation	<p>Activate and deactivate multifunction input and output MF1 and multifunction output MF2.</p> <p>Read/Write access</p> <ul style="list-style-type: none"> • Read and write <p>Input value</p> <ul style="list-style-type: none"> • 0: off / 1: on <p>Factory setting</p> <ul style="list-style-type: none"> • On

Table 36: Page "Parameter settings" – field "MF1/MF2 activation"

Field "MF1 Function configuration" Requirements for the display

- Parameter "MF1 activation": Option "Enable"

Parameter	Description
Function	<p>Select function for multifunction input and output MF1.</p> <p>Read/Write access</p> <ul style="list-style-type: none"> • Read and write <p>Input value</p> <ul style="list-style-type: none"> • 0: Distance: → See page 60, field "MF1, Threshold distance underflow" • 1: Velocity: → See page 61, field "MF1, Threshold velocity exceeded" • 2: Service: → See page 61, field "MF1, Service configuration" • 3: Laser • 4: Preset <p>Factory setting</p> <ul style="list-style-type: none"> • Distance
Active condition	<p>Select level for the active condition for the multifunction input and output MF1.</p> <p>Read/Write access</p> <ul style="list-style-type: none"> • Read and write <p>Input value</p> <ul style="list-style-type: none"> • 0: high / 1: low <p>Factory setting</p> <ul style="list-style-type: none"> • Low

Table 37: Page "Parameter settings" – field "MF1 Function configuration"

Operation via Ethernet (Ethernet interface)

Field "MF1, Threshold distance underflow"

Requirements for the display

- Parameter "MF1 activation": Option "Enable"
- Parameter "Function": Option "Distance"

Parameter	Description
Threshold distance	Enter switching threshold for the multifunction output MF1. Read/Write access <ul style="list-style-type: none"> • Read and write Input value <ul style="list-style-type: none"> • -300000 ... 300000 Unit <ul style="list-style-type: none"> • mm Factory setting <ul style="list-style-type: none"> • 1990
Hysteresis distance	Enter hysteresis for switching threshold for the multifunction output MF1. Read/Write access <ul style="list-style-type: none"> • Read and write Input value <ul style="list-style-type: none"> • 1 ... 300000 Unit <ul style="list-style-type: none"> • mm Factory setting <ul style="list-style-type: none"> • 10

Table 38: Page "Parameter settings" – field "MF1, Threshold distance underflow"

Field "MF1, Threshold velocity exceeded"

Requirements for the display

- Parameter "MF1 activation": Option "Enable"
- Parameter "Function": Option "Velocity"

Parameter	Description
Threshold velocity	Enter switching threshold for the multifunction output MF1. Read/Write access <ul style="list-style-type: none"> • Read and write Input value <ul style="list-style-type: none"> • 0 ... 15000 Unit <ul style="list-style-type: none"> • mm/s Factory setting <ul style="list-style-type: none"> • 5000

Operation via Ethernet (Ethernet interface)

Field "MF1, Threshold velocity exceeded" (continued)

Parameter	Description
Distance change	<p>Choose the travel direction to be monitored.</p> <p>Read/Write access</p> <ul style="list-style-type: none"> • Read and write <p>Input value</p> <ul style="list-style-type: none"> • 0: Increasing (positive values) / 1: decreasing (negative values) / 2: increasing and decreasing <p>Factory setting</p> <ul style="list-style-type: none"> • increasing and decreasing

Table 39: Page "Parameter settings" – field "MF1, Threshold velocity exceeded"

Field "MF1, Service configuration"

Requirements for the display

- Parameter "MF1 activation": Option "Enable"
- Parameter "Function": Option "Service"

Parameter	Description
Configuration device monitoring	<p>Activating and deactivating warning messages. When the event for the warning message occurs, the multifunction switching output MF1 switches.</p> <p>Read/Write access</p> <ul style="list-style-type: none"> • Read and write <p>Input value</p> <p>You may activate several warning messages at once.</p> <ul style="list-style-type: none"> • Warning measurement stability • Warning level • Warning laser • Warning temperature • Device not ready • Heater state (for device model with heating) <p>Factory setting</p> <ul style="list-style-type: none"> • The warning messages "Measurement stability", "Level", "Laser", "Temperature" and "Device not ready" are activated. The message "Heater state" is deactivated.

Table 40: Page "Parameter settings" – field "MF1, Service configuration"

Operation via Ethernet (Ethernet interface)

Field "MF2 Function configuration" Requirements for the display

- Parameter "MF2 activation": Option "Enable"

Parameter	Description
Function	Select function for the multifunction MF2 output. Read/Write access • Read and write Input value • 0: Distance / 1: Velocity / 2: Service Factory setting • Service
Active state	Select level for the active condition for the multifunction output MF2. Read/Write access • Read and write Input value • 0: high / 1: low Factory setting • Low

Table 41: Page "Parameter settings" – field "MF2 Function configuration"

Field "MF2, Threshold distance underflow"

→ See page 60, Table 38, "MF1, Threshold distance underflow"

Field "MF2, Threshold exceeded exceeded"

→ See page 61, Table 39, "MF1, Threshold velocity exceeded"

Field "MF2, Service configuration"

→ See page 61, Table 40, "MF1, Service configuration"

Field "Number of MF activation"

Parameter	Description
MF1	Counts the switching events of the multifunction input and output MF1. You may reset the counters via the button "Reset MF1". Read/Write access • Read and write Input value • -2147483648 ... 2147483647
M2	Counts the switching events of the multifunction output MF2. You may reset the counters via the button "Reset MF2". Read/Write access • Read and write Input value • -2147483648 ... 2147483647

Table 42: Page "Parameter settings" – field "Number MF activation"

Operation via Ethernet (Ethernet interface)

Field "Advanced device functions"

Parameter	Description
Average filter distance	Select filter depth for the distance values. Read/Write access • Read and write Input value • 0: fast / 1: medium / 2: slow Factory setting • Medium
Average filter velocity	Select filter depth for the speed values. Read/Write access • Read and write Input value • 0: fast / 1: medium / 2: slow Factory setting • Medium
Error rejection	Select time for error suppression. If there is an error, the measurement value is indicated as "0". Read/Write access • Read and write Input value • 0: off / 1: 50 ms / 2: 200 ms Factory setting • 200 ms

Table 43: Page "Parameter settings" – field "Advanced device function"

Field "Heater"

Requirements for the display

- Devices with the option "Heating" (DL100-xxHxxxxx)

Parameter	Description
Heater threshold	Enter power up threshold for heating. Read/Write access • Read and write Input value • -10 ... +40 Unit • °C Factory setting • -10

Table 44: Page "Parameter settings" – field "Heater"

Operation via Ethernet (Ethernet interface)

Field "Store parameter"

Parameter	Description
Storage	Parameter changes only enter into permanent effect if they are saved via the button "Storage". Read/Write access <ul style="list-style-type: none"> • Write only

Table 45: Page "Parameter settings" – field "Store parameter"

Field "Set parameters to default values"

Parameter	Description
Parameter Reset	Click the button "Parameter Reset" to reset the parameters to factory settings. Read/Write access <ul style="list-style-type: none"> • Write only

Table 46: Page "Parameter settings" – field "Set parameters to default values"

9.2.6 Methods

Field	Description
Device reboot	<ul style="list-style-type: none"> Click the button "Reboot" to cause the device to restart. <p>Read/Write access</p> <ul style="list-style-type: none"> Write only
Laser control	<p>Switch the laser on and off as follows:</p> <ul style="list-style-type: none"> Use the selection button to select the desired option. Click the button to perform the option. <p>Read/Write access</p> <ul style="list-style-type: none"> Write only <p>Input value</p> <ul style="list-style-type: none"> 0: off / 1: on <p>Factory setting</p> <ul style="list-style-type: none"> Off
Heating control	<p>Control the heating as follows:</p> <ul style="list-style-type: none"> Use the selection button to select the desired option. Click the button to perform the option. <p>Read/Write access</p> <ul style="list-style-type: none"> Write only <p>Input value</p> <ul style="list-style-type: none"> 0: Off / 1: On / 2: Auto <p>Factory setting</p> <ul style="list-style-type: none"> Auto

Table 47: Page "Methods"

EtherNet/IP-interface

10 EtherNet/IP-interface

Hinweis:

Nach PDF-Generierung Seiten 66 bis 87 ersetzen durch Datei „DL100-EIP-Interfacebeschreibung_angepasst .doc“

EtherNet/IP-interface

EtherNet/IP-interface

EtherNet/IP-interface

EtherNet/IP-interface

EtherNet/IP-interface

EtherNet/IP-interface

EtherNet/IP-interface

EtherNet/IP-interface

EtherNet/IP-interface

EtherNet/IP-interface

Cleaning and maintenance

11 Cleaning and maintenance

11.1 Cleaning



ATTENTION!

Damage to the device from improper cleaning!

Improper cleaning may cause damage to the device.

Therefore:

- Do not use any cleaning agents with aggressive contents.
- Do not use any pointed objects for cleaning.

Clean the front screens with a lint-free cloth and plastic cleaning agent at regular intervals.

The cleaning interval mainly depends on the ambient conditions.

11.2 Maintenance

The distance measuring device DL100 requires the following maintenance work at regular intervals:

Interval	Maintenance work	To be performed by
Cleaning intervals depending on ambience conditions and climate	Cleaning housing	Skilled person
Every 6 months	Check screw and plug connections at regular intervals.	Skilled person

Table 48: Maintenance plan

12 Troubleshooting

The following table describes possible interferences and measures for removal.

Contact the manufacturer for interferences that cannot be removed based on the following description. You can find your local office on the reverse.

General interferences, warnings and errors

The distance measuring device differentiates between general interferences, warnings and errors. General interferences are not displayed. When a warning is pending, the LED **PWR** flashes orange. A measurement value is output. When an error is pending, the LED **PWR** flashes red. The measurement value "0" is output.

12.1 LED status indicators

Display	Possible causes	Troubleshooting
The display shows the value "0000".	The measuring device's light spot does not hit the reflector.	Correct alignment between measuring device and reflector.
	The obstacle is in the light path.	Remove obstacle from the light path.
	Distance between distance measuring device and reflector exceeds the maximum scanning range indicated in the technical data. → see page 95, chapter 14.4.	<ul style="list-style-type: none"> Decrease the distance between the distance measuring device and the reflector. Select a distance measuring device with a larger maximum scanning range.
LED PWR is not lit. Display is lit.	Measuring device defective.	Send in device for repair.
LED PWR flashes orange.	A warning is pending.	→ For possible causes and their removal, see page 89, chapter 12.2.
LED PWR flashes red.	An error is pending.	→ For possible causes and their removal, see page 90, chapter 12.3.
LED BF and SF are not lit red.	Connection OK	–
LED BF and SF are lit red.	Status after switching on. Bus interrupted Master (PLC) cannot be reached. No data are exchanged.	<ul style="list-style-type: none"> Wait for a few minutes. Check wiring.
LED BF flashes red. LED SF is lit red.	Device (slave) is not configured or not configured correctly. No data are exchanged.	<ul style="list-style-type: none"> Configure device. Check configuration.

Table 49: LED status display

12.2 Warning messages

Display	Meaning / possible causes	Troubleshooting
NoWrn	No warnings	–
wPlb	Measured value not plausible. Light path between measuring device and reflector interrupted.	Observe light spot on the reflector. The light spot must not move from the reflector. If required, re-align measuring device and reflector or use a larger reflector. → For alignment and mounting, see page 24, chapter 6.
	Optical interferences	<ul style="list-style-type: none"> Remove optical interferences. Re-align distance measuring device and reflector. → For alignment and mounting, see page 24, chapter 6.
wLaser	The measurement laser is still operational but at the end of its service life.	Keep replacement device ready.

Troubleshooting

Display	Meaning / possible causes	Troubleshooting
wLevel	Current damping value is below the recommended damping value. The recommended damping value depends on the distance between measuring device and reflector. → For recommended damping values, see page 29, Table 6.	<ul style="list-style-type: none"> • Clean external lens surfaces like the reflector and the lens • Decrease the distance between the measuring device and the reflector. • Use a distance measuring device with a higher range. → See page 94, chapter 14.2.
wTemp	Internal device temperature is close to the permissible range. → For the permissible ambient temperature, see page 96, chapter 14.9.	<ul style="list-style-type: none"> • Check ambience temperature, improve ventilation if applicable. • Shield against radiation heat, e.g. shade the measuring device in case of direct solar irradiation. • Use device with heating at low ambient temperatures. • Use cooling housings for high ambient temperatures.

Table 50: Warning messages

12.3 Error messages

Display	Meaning / possible causes	Troubleshooting
NoErr	No error	–
ePlb	Measured value not plausible. Light path between measuring device and reflector interrupted.	Observe light spot on the reflector. The light spot must not move from the reflector. If required, re-align measuring device and reflector or use a larger reflector. → For alignment and mounting, see page 24, chapter 6.
	Optical interferences	<ul style="list-style-type: none"> • Remove optical interferences. • Re-align distance measuring device and reflector. → For alignment and mounting, see page 24, chapter 6.
eLaser	The service life of a measurement laser is exceeded.	Interchange measuring device.
eLevel	Current damping value is below the warning threshold. The warning threshold depends on the distance between measuring device and reflector. → For recommended damping values, see page 29, Table 6.	<ul style="list-style-type: none"> • Clean external lens surfaces like the reflector and the lens. • Decrease the distance between the measuring device and the reflector. • Use a distance measuring device with a higher range. → see page 94, chapter 14.2.
eTemp	The internal device temperature is outside of the permissible range. → For the permissible ambient temperature, see page 96, chapter 14.9.	<ul style="list-style-type: none"> • Check ambience temperature, improve ventilation if applicable. • Shield against radiation heat, e.g. shade the measuring device in case of direct solar irradiation. • Use device with heating at low ambient temperatures. • Use cooling housings for high ambient temperatures.

Table 51: Error messages

12.4 PROFINET IO error messages

Display	Meaning / possible causes	Troubleshooting
Device error	Hardware	<ul style="list-style-type: none"> • Check supply voltage and wiring. → For electrical connection, see page 32, chapter 7. • Switch supply voltage on and off. • Send in measuring device for repair.
	The internal devicetemperature is outside of the permissible range. → For the permissible ambient temperature, see page 96, chapter 14.9.	<ul style="list-style-type: none"> • Wait for warm-up phase of the measuring device. Let the measuring device cool down. • Check ambience temperature, improve ventilation if applicable. • Shield against radiation heat, e.g. shade the measuring device in case of direct solar irradiation. • Use device with heating at low ambient temperatures. • Use cooling housings for high ambient temperatures.
Measuring error	Light path between measuring device and reflector interrupted.	Keep replacement device ready.
	Current damping value is below the recommended damping value. The recommended damping value depends on the distance between measuring device and reflector. → For recommended damping values, see page 29, Table 6.	Clean external lens surfaces like the reflector and the lens
	Lens or reflector contaminated.	Clean external lens surfaces like the reflector and the lens
	Movement too fast.	Check maximum movement speed.
Pre-failure recognition	The measurement laser is still operational but at the end of its service life.	Keep replacement device ready.
	Current damping value is below the recommended damping value. The recommended damping value depends on the distance between measuring device and reflector. → For recommended damping values, see page 29, table 5.	Clean external lens surfaces like the reflector and the lens
	Lens or reflector contaminated.	Clean external lens surfaces like the reflector and the lens
	The internal devicetemperature is within the threshold range. → For the permissible ambient temperature, see page 106, chapter 14.8.	Check ambient temperature.

Table 52: PROFINET IO error messages

Repair

12.5 Return

For efficient processing and quick determination of causes, include the following in your return:

- Information on a contact
- A description of the application
- A description of the error that occurred

12.6 Disposal

Observe the following items for disposal:

- The distance measuring device must not be disposed of in the household waste.
- Dispose of the distance measuring device according to the respective country-specific provisions.

13 Repair

Repairs must only be performed by the manufacturer. The manufacturer's warranty will lapse in case of interruptions and changes to the device.

14 Technical data



NOTE!

You may download, save and print the online datasheet with technical data, dimensions and connection diagrams for your distance measuring device online at "www.sick.com/dl100".

14.1 Dimensions

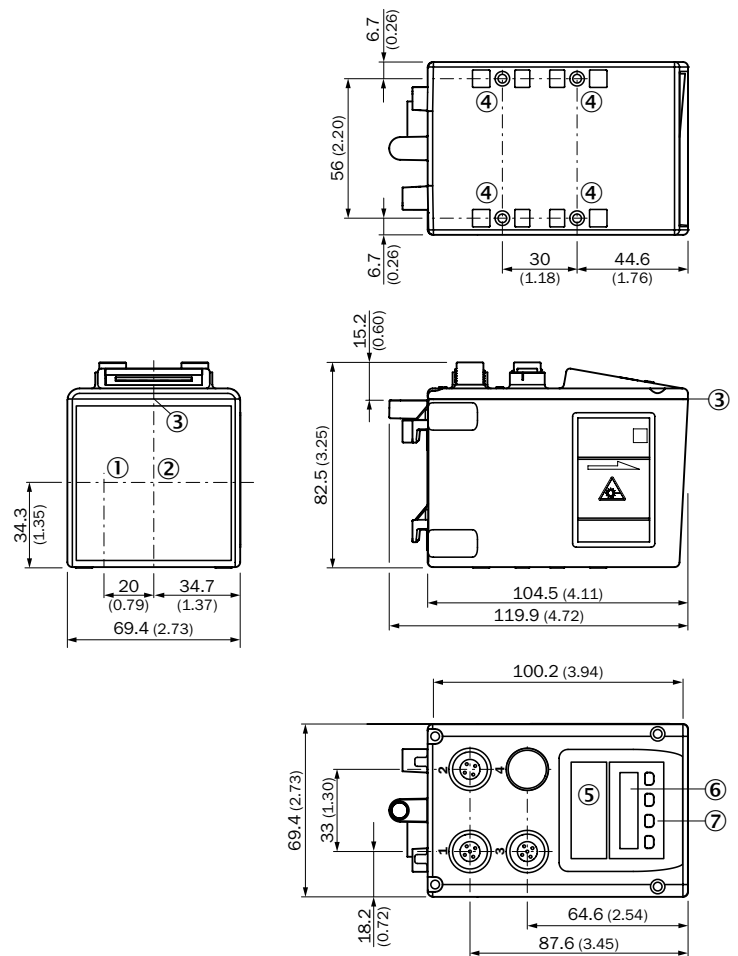

All dimensions in mm (inch)

Fig. 25: Dimensions distance measuring device DL100

- 1 Optical axis sender
- 2 Optical axis receiver
- 3 Device zero point
- 4 Threaded mounting hole M5
- 5 LED "Status"
- 6 Display
- 7 Operating elements

Technical data

14.2 Device selection EtherNet/IP-interface

Ambient temperature	Power consumption at 24 V DC	Measuring range	Accuracy	Operating mode	Repeatability ¹⁾	Dead time	Order no.	Type code
[°C]	[mA]	[m]	[mm]		[mm]			
-20 ... +55 -20 ... +75 (with TPCC cooling case 6048328) ²⁾	<250	0,15 ... 100	± 2,0	Fast/Medium	1,5	10	1066433	DL100-11AA2110
				Slow	0,75	30		
		0,15 ... 200	± 2,5	Fast/Medium	2,0	10	1066434	DL100-12AA2110
				Slow	1,0	30		
		0,15 ... 300	± 3,0	Fast/Medium	2,5	10	1066435	DL100-13AA2110
				Slow	1,25	30		
-40 ... +55 (with integrated heating) -40 ... +75 (with TPCC cooling case 6048328)	<1000	0,15 ... 100	± 2,0	Fast/Medium	1,5	10	1066430	DL100-11HA2110
				Slow	0,75	30		
		0,15 ... 200	± 2,5	Fast/Medium	2,0	10	1066431	DL100-12HA2110
				Slow	1,0	30		
		0,15 ... 300	± 3,0	Fast/Medium	2,5	10	1066432	DL100-13HA2110
				Slow	1,25	30		

1) Statistic error 1 σ, in function of operating mode

2) For temperatures below -10 °C, a start-up time of typically 7 minutes is required.

Table 53: Device selection



NOTE!

→ For additional information about the variants of other interfaces, please see "www.sick.com/dl100".

14.3 Laser/optics

Light source	Laser diode, red light
Laser protection class	2 pursuant to EN 60825-1:2014+A11:2021 /CDRH
CW modulation	± 0.85 Po sine-shape modulated
Maximum output	≤ 1.9 mW
Pulse duration	6.8 ns

Wave length	655 nm
Frequency	≥ 90 MHz
Light spot dimensions	Typical 5 mm + (2 mm x distance [m])
Average service life	Typically 100 000h at +25 °C

Table 54: Laser/Optics

14.4 Performance

Measurement ranges	<ul style="list-style-type: none"> DL100-11XXXXXX: 0.15 m ... 60 m DL100-12XXXXXX: 0.15 m ... 130 m DL100-13XXXXXX: 0.15 m ... 220 m
Measuring accuracy	See type specific data → See page 94, chapter 14.2
Repeatability	See type specific data → See page 94, chapter 14.2
Initialization time	<ul style="list-style-type: none"> Typical 1.5 s After reflector loss: < 40 ms
Reaction time/dead time	See type specific data → See page 94, chapter 14.2
Resolution	Adjustable: 0.1 mm / 0.125 mm / 1.0 mm / 10 mm / 100 mm
Output rate	synchronous to PLC request

Table 55: Performance data

14.5 Supply

Supply voltage V_s	18 V DC ... 30 V DC
Current consumption	<ul style="list-style-type: none"> Without heating: < 250 mA at 24 V DC With heating : < 1.000 mA at 24 V DC
Residual ripple	< 5 V_{ss} within the permissible supply voltage U_v

Table 56: Supply

14.6 Inputs

Inputs	<p>Multifunction input MF1, adjustable</p> <ul style="list-style-type: none"> Hi > 12 V Lo < 3 V <p>→ See page 43, Table 15, parameter "ActSta".</p>
Protective circuit	No, not reverse polarity protected

Table 57: Inputs

Technical data

14.7 Outputs

Outputs	Multifunction outputs MF1 and MF2, type: B (push/pull), adjustable <ul style="list-style-type: none"> • Hi > UV – 3 V • Lo < 2 V → See page 43, Table 15 and page 49, Table 20, parameter “ActSta2.”
Maximum output current	Max. 100 mA
Output load	<ul style="list-style-type: none"> • Capacity: 100 nF • Inductive 20 mH

Table 58: Outputs

14.8 Interfaces

Data interface	PROFINET IO / RT, Conformance Class B, PN specification V2.25, Process data interface, access via SOPAS ET
Data transmission rate	100 Mbit/s full duplex

Table 59: Interfaces

14.9 Ambient conditions

Protection class	III Suitable for operation in PELV systems (Protective Extra Low Voltage - safety extra-low voltage) with secure separation.
Electromagnetic compatibility ¹⁾	EN 61000-6-2, EN 55011, category A
Ambient temperature range	See type-specific data
Storage temperature range	-40 °C ... +75 °C
Enclosure rating	IP65
Air pressure influence	0.3 ppm/hPa
Temperature influence	1 ppm/K
Temperature drift	Typical 0.1 mm/K
Maximum movement speed	10 m/s
Maximum acceleration change	10 m/s ²
Vibration resistance (sine)	EN60068-2-6
Noise	EN60068-2-64
Shock resistance	EN 60086-2-27

1) When used in the household area, the device may cause interferences.

Table 60: Ambient conditions

14.10 Constructive setup

Dimensions	→ See page 93, chapter 14.1.
Weight	<ul style="list-style-type: none"> Distance measuring device: 800 g Alignment bracket (optional): 800 g
Materials	<ul style="list-style-type: none"> Casing: Cast aluminium GD-ALSi12Cu1 (3.2982.05) Front screen: PMMA
Connections	M12, SpeedCon™
Display	<ul style="list-style-type: none"> 6 points with a 5 x 7 point matrix Overflow is displayed with the maximum value that can be displayed, -99999 bzw. 999999.

Table 61: Constructive setup

Accessories

15 Accessories



Note!

Only some of the available accessories are shown here. Complete details on all accessories are available at www.sick.com/dl100

15.1 Reflectors and reflective tape

15.1.1 Reflectors

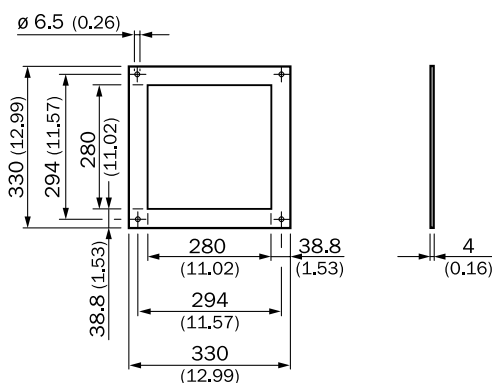

All dimensions in mm (inch)

Fig. 26: Reflector 0.3 x 0.3 m² Diamond Grade, mounted

Description	Reflector 0.3 x 0.3 m ² Diamond Grade, mounted on base plate ALMG3
Type	PL240DG
Part no.	1017910

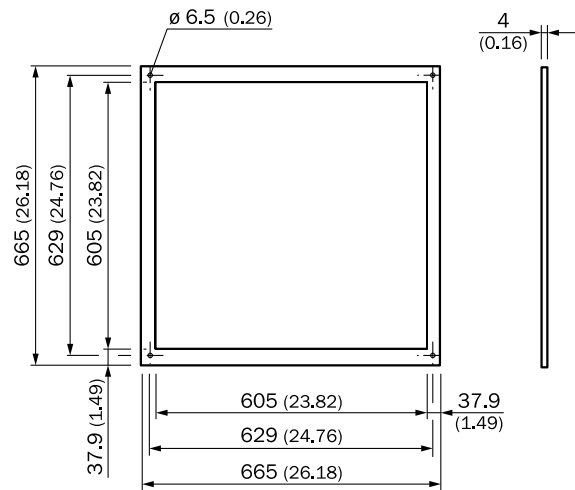

All dimensions in mm (inch)

Fig. 27: Reflector 0.6 x 0.6 m² Diamond Grade, mounted

Description	Reflector 0.6 x 0.6 m ² Diamond Grade, mounted on base plate ALMG3
Type	PL560DG
Part no.	1016806

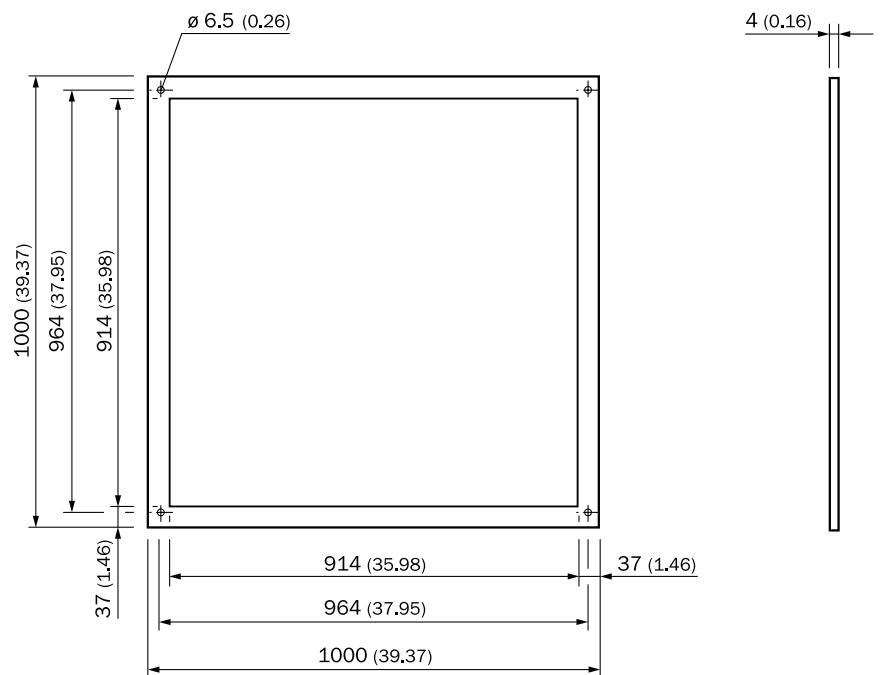

All dimensions in mm (inch)

Fig. 28: Reflector 1.0 x 1.0 m² Diamond Grade, mounted

Description	Reflector 1.0 x 1.0 m ² Diamond Grade, mounted on base plate ALMG3
Type	PL880DG
Part no.	1018975

Accessories

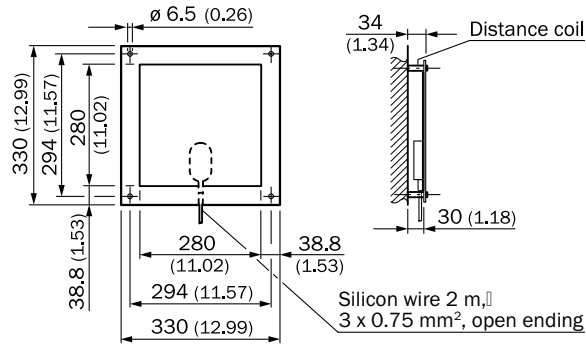

All dimensions in mm (inch)

Fig. 29: Reflector 0.3 x 0.3 m² Diamond Grade, mounted, including heating

Description	Reflector 0.3 x 0.3 m ² Diamond Grade, mounted, on base plate ALMG3, including controlled heating +20 °C, 230 V AC, 200 W, IP 64
Type	PL240DG-H
Part no.	1022926

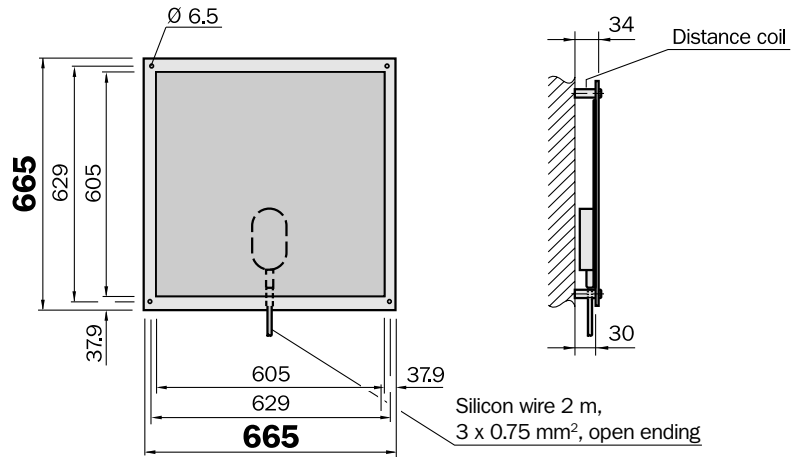

Fig. 30: Reflector 0.6 x 0.6 m² Diamond Grade, mounted, including heating

Description	Reflector 0.6 x 0.6 m ² Diamond Grade, mounted, on base plate ALMG3, including controlled heating +20 °C, 230 V AC, 200 W, IP 64
Type	PL560DG-H
Part no.	1023888

15.1.2 Reflektiv tape



Fig. 31: "Diamond grade" reflective tape

Description	"Diamond grade" reflective tape, size customizable
Type	REF-DG
Part no.	4019634
Description	"Diamond grade" reflective tape, curve 749 x 914 mm ²
Type	REF-DG
Part no.	5320565

15.2 Connection systems



Note!

Complete details on all accessories are available at www.sick.com/dl100

Accessories

15.3 Mounting systems

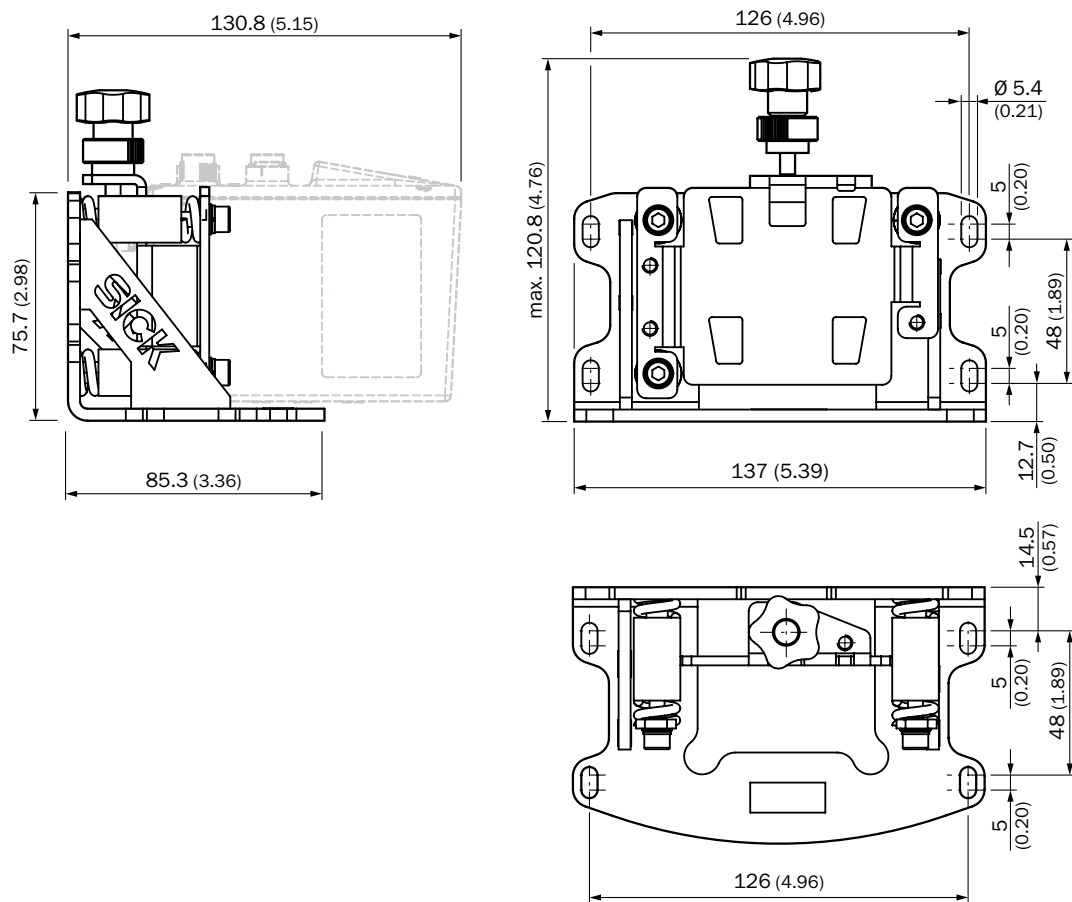

All dimensions in mm (inch)

Fig. 32: Alignment bracket

Description	Alignment bracket
Type	BEF-AH-DX100
Part no.	2058653
Material:	Zinc-plated steel sheet

15.4 Other accessories

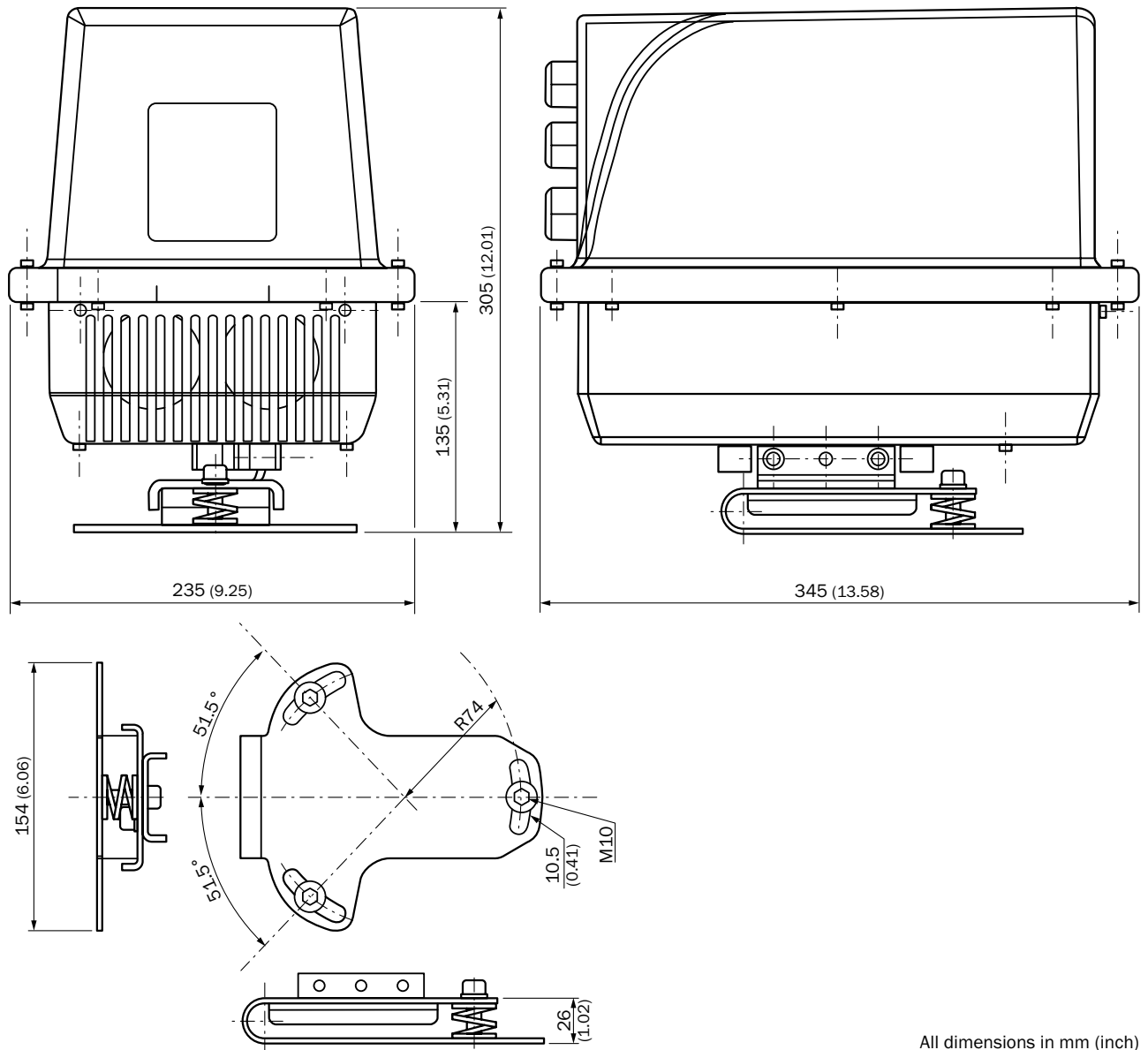

All dimensions in mm (inch)

Fig. 33: Cooling Casing

Description	Cooling Casing
Type	TPCC-Dx100
Part no.	6048328
Material	Glass-fiber reinforced plastic (GFK)
Operating ambience temperature	-20 ... +75 °C (short-term +80 °C)
Supply voltage	24 V DC ± 20 %
Current consumption	15 A at 24 V DC
Enclosure rating	IP 54

Menu structure

16 Menu structure

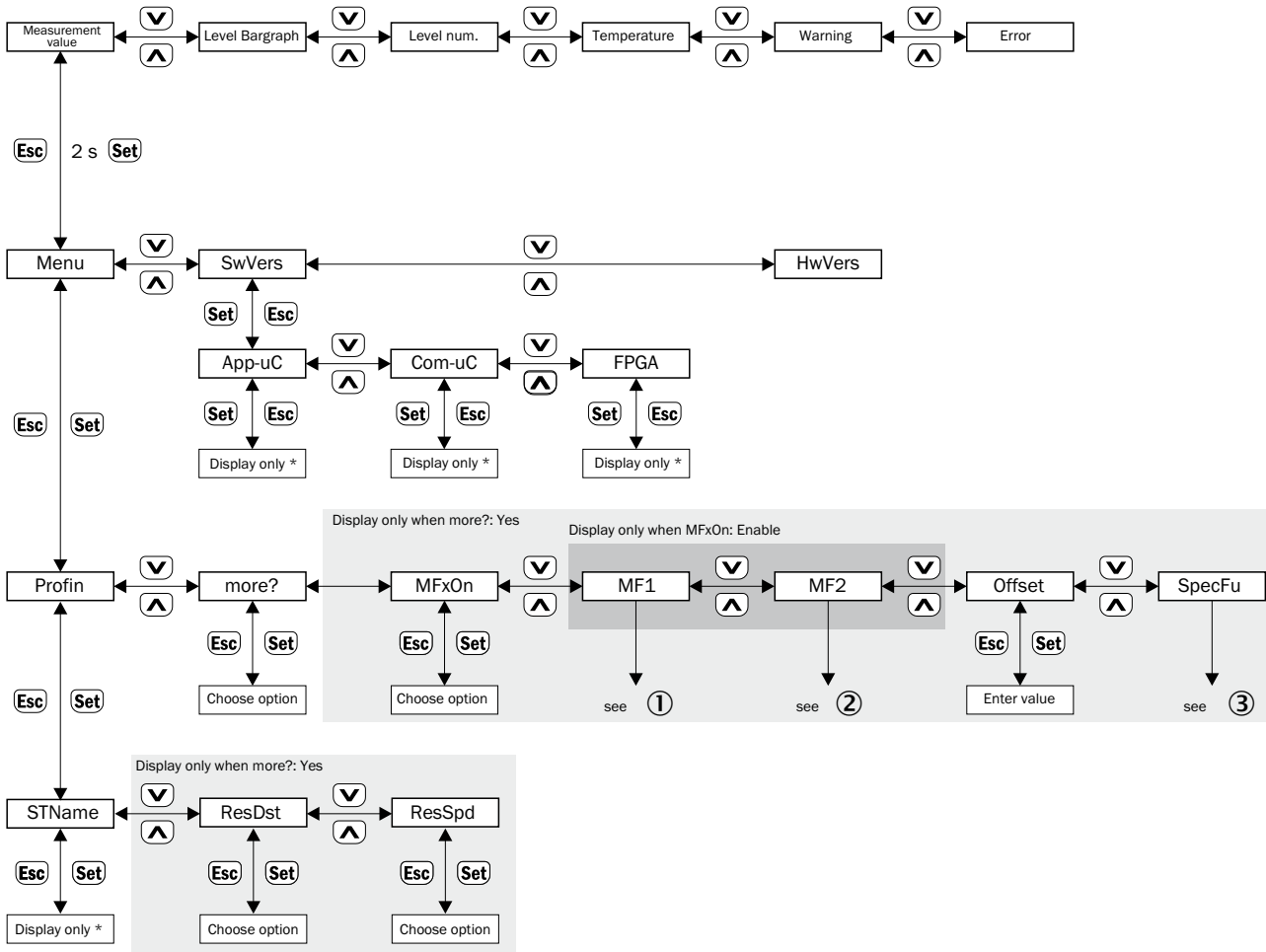

* Display as ticker

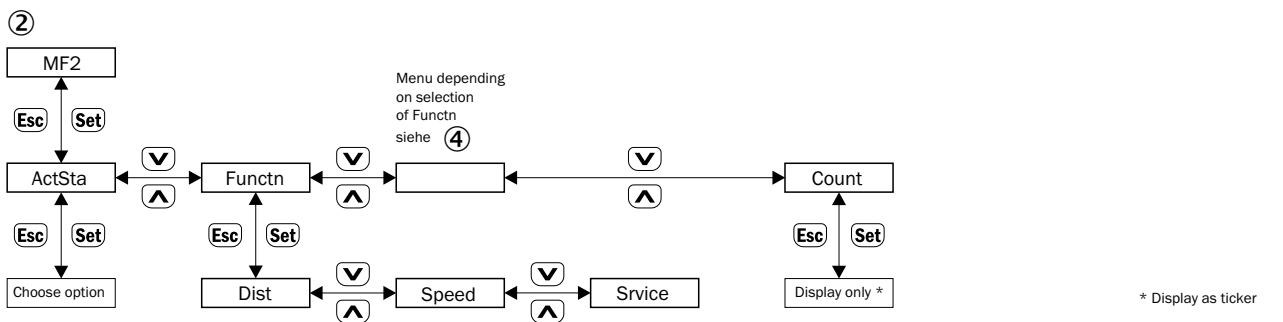
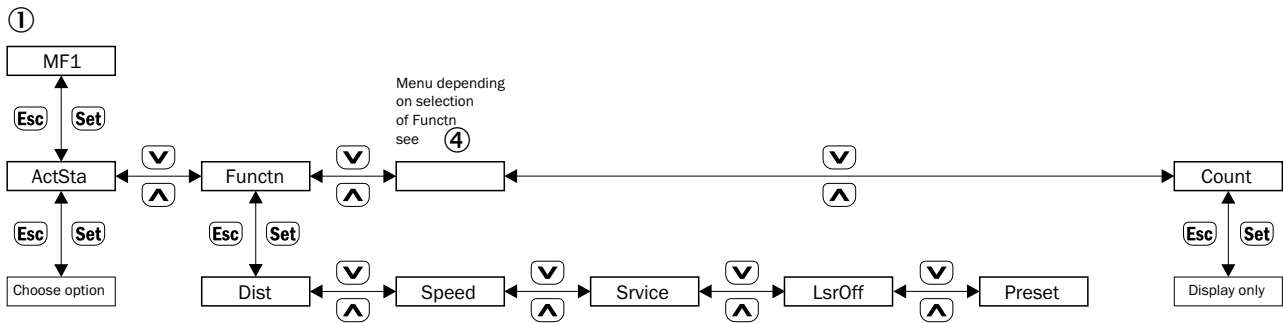

* Display as ticker

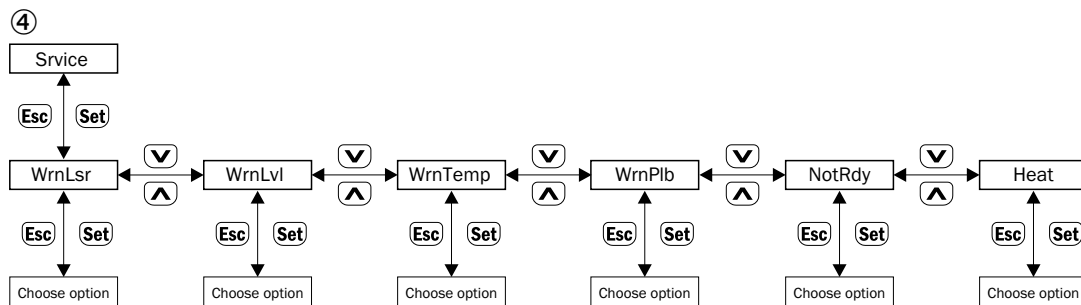
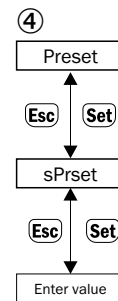
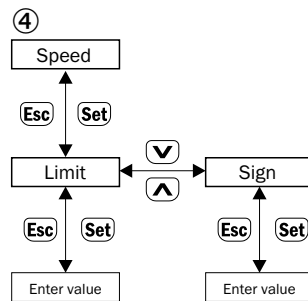
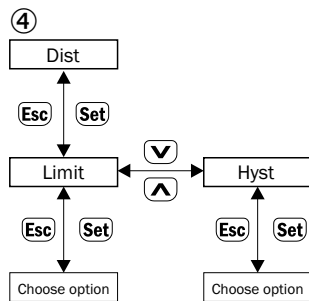
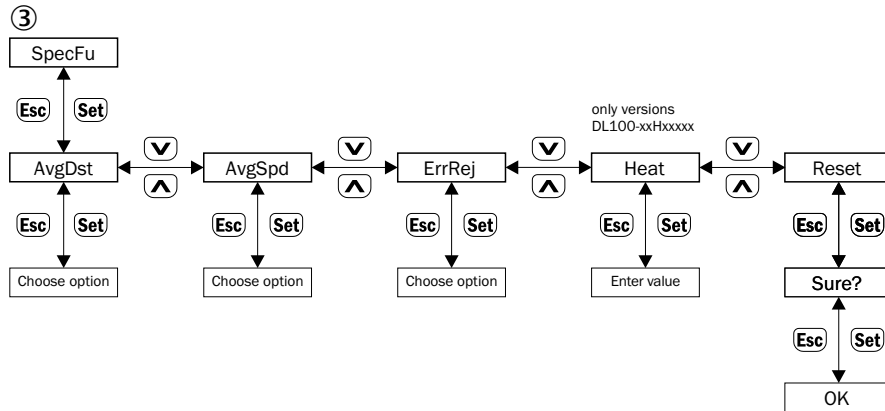

Index

Index

A		I	
Accessories.....	98	Identification.....	16
Alignment bracket	102	Inputs.....	95
Connecting systems	101	Instructed persons.....	13
Cooling casing.....	103	Intended Use	12
Miscellaneous.....	103	Interfaces.....	96
Reflectors	98	K	
Align		Keys.....	20
Distance measuring device and reflector	28	L	
Via alignment bracket	31	Laser	94
Alignment bracket		Laser irradiation	15
Mounting.....	29	LEDs.....	19
Ambient conditions	96	BF und SF.....	20
C		MF1/2	20
Changes.....	12	Status indicators.....	89
Cleaning.....	88	Limitations of liability.....	10
Connection diagram		M	
Port 1, Port 2 (Ethernet/PROFINET IO)	37	Maintenance	88
Supply voltage.....	36	Menu structure.....	104
Connection systems (accessories)	101	Minimum distance	26
Constructive setup	97	Mounting.....	24
Conversions.....	12	Alignment bracket and distance measuring	
Customer service	10	device	29
D		Distance measuring device	29
Damping		Distance measuring device and adjacent data	
Rated level	29	transmission photoelectric switch.....	27
Warning threshold	29	Minimum distance.....	26, 27
Danger notes Laser irradiation.....	15	Multiple distance measuring device	26
Delivery	10	Notes	24
Device selection	94	Process.....	24
Dimensions.....	93	Reflector.....	24
Alignment bracket	102	Mounting systems	102
Distance measuring device	93	N	
Display	21	Non-Intended Use	12
Disposal	92	O	
E		Operating elements.....	19
EC Declaration of Conformity	10	Operating instructions	8
Electrical connection.....	32	Operating modes.....	20, 21
Electricians	13	Operating staff	
Environmental protection	11	Requirements	13
Error messages	90	Operation	37
Ethernet	53	At measuring device.....	37
F		Change value	38
Factory settings.....	52	Choose option.....	38
Function	18	Choose parameter.....	38
G		Via Ethernet	53
General	8		

Operational safety	13, 15	Measurement value resolution.....	58
Outputs	96	Measurement values	56
P		Methods	65
Parameter description	39	MF1 Function configuration	59
Dist (MF1)	44	MF1/MF2 activation.....	58
Dist (MF2)	49	MF1 Service configuration.....	61
HwVers	40	MF1, Threshold.....	60
Main menu.....	39	MF2, Threshold.....	62
MF1	43	Number of MF activation	62
MF2	49	Parameter default values	64
MFx On	42	Product code.....	54
more	41	PROFINET IO configuration	58
Offset.....	50	Service configuration.....	62
Profin	40	Software versions.....	54
SpecFu	50	Store parameter	64
Speed (MF1).....	45	Store user information	55
Speed (MF2).....	49	User information.....	55
Srvce (MF1).....	46	Status indicators	19
Srvce (MF2).....	49	Storage.....	23
SwVers.....	39	Supply	95
Performance data	95	T	
Preset		Technical Data.....	93
Description.....	47	Transport.....	22
PROFINET IO	66	Transport inspection	22
Error messages.....	91	Troubleshooting.....	88
R		Type code.....	94
Reflective tape.....	101	Type Label.....	16
Reflector		U	
Alignment.....	28	UL safety notes.....	7
Mounting.....	24	W	
Selection	24	Warning messages.....	89
Reflectors.....	98	Wiring Notes	33
Accessories.....	98		
Repair.....	92		
Reset.....	52		
Return	92		
S			
Safety	11		
Electrical connection.....	32		
Setup.....	17		
Skilled persons.....	13		
Requirements	13		
SOPAS ET			
Advanced device functions	63		
Device information	53		
Device name.....	54		
Diagnostic data.....	56		
Distance value	55		
Function configuration	62		
General settings	57		
Hardware version.....	54		
Heater.....	63		

Australia

Phone +61 (3) 9457 0600
1800 33 48 02 – tollfree
E-Mail sales@sick.com.au

Austria

Phone +43 (0) 2236 62288-0
E-Mail office@sick.at

Belgium/Luxembourg

Phone +32 (0) 2 466 55 66
E-Mail info@sick.be

Brazil

Phone +55 11 3215-4900
E-Mail comercial@sick.com.br

Canada

Phone +1 905.771.1444
E-Mail cs.canada@sick.com

Czech Republic

Phone +420 234 719 500
E-Mail sick@sick.cz

Chile

Phone +56 (2) 2274 7430
E-Mail chile@sick.com

China

Phone +86 20 2882 3600
E-Mail info.china@sick.net.cn

Denmark

Phone +45 45 82 64 00
E-Mail sick@sick.dk

Finland

Phone +358-9-25 15 800
E-Mail sick@sick.fi

France

Phone +33 1 64 62 35 00
E-Mail info@sick.fr

Germany

Phone +49 (0) 2 11 53 010
E-Mail info@sick.de

Greece

Phone +30 210 6825100
E-Mail office@sick.com.gr

Hong Kong

Phone +852 2153 6300
E-Mail ghk@sick.com.hk

Hungary

Phone +36 1 371 2680
E-Mail ertekesites@sick.hu

India

Phone +91-22-6119 8900
E-Mail info@sick-india.com

Israel

Phone +972 97110 11
E-Mail info@sick-sensors.com

Italy

Phone +39 02 27 43 41
E-Mail info@sick.it

Japan

Phone +81 3 5309 2112
E-Mail support@sick.jp

Malaysia

Phone +603-8080 7425
E-Mail enquiry.my@sick.com

Mexico

Phone +52 (472) 748 9451
E-Mail mexico@sick.com

Netherlands

Phone +31 (0) 30 229 25 44
E-Mail info@sick.nl

New Zealand

Phone +64 9 415 0459
0800 222 278 – tollfree
E-Mail sales@sick.co.nz

Norway

Phone +47 67 81 50 00
E-Mail sick@sick.no

Poland

Phone +48 22 539 41 00
E-Mail info@sick.pl

Romania

Phone +40 356-17 11 20
E-Mail office@sick.ro

Russia

Phone +7 495 283 09 90
E-Mail info@sick.ru

Singapore

Phone +65 6744 3732
E-Mail sales.gsg@sick.com

Slovakia

Phone +421 482 901 201
E-Mail mail@sick-sk.sk

Slovenia

Phone +386 591 78849
E-Mail office@sick.si

South Africa

Phone +27 10 060 0550
E-Mail info@sickautomation.co.za

South Korea

Phone +82 2 786 6321/4
E-Mail infokorea@sick.com

Spain

Phone +34 93 480 31 00
E-Mail info@sick.es

Sweden

Phone +46 10 110 10 00
E-Mail info@sick.se

Switzerland

Phone +41 41 619 29 39
E-Mail contact@sick.ch

Taiwan

Phone +886-2-2375-6288
E-Mail sales@sick.com.tw

Thailand

Phone +66 2 645 0009
E-Mail marcom.th@sick.com

Turkey

Phone +90 (216) 528 50 00
E-Mail info@sick.com.tr

United Arab Emirates

Phone +971 (0) 4 88 65 878
E-Mail contact@sick.ae

United Kingdom

Phone +44 (0)17278 31121
E-Mail info@sick.co.uk

USA

Phone +1 800.325.7425
E-Mail info@sick.com

Vietnam

Phone +65 6744 3732
E-Mail sales.gsg@sick.com

Detailed addresses and further locations at www.sick.com