

ReLy OSSD3

Safety relay

SICK
Sensor Intelligence.



Described product

ReLy OSSD3

Manufacturer

SICK AG
Erwin-Sick-Str. 1
79183 Waldkirch
Germany

Legal information

This work is protected by copyright. Any rights derived from the copyright shall be reserved for SICK AG. Reproduction of this document or parts of this document is only permissible within the limits of the legal determination of Copyright Law. Any modification, abridgment or translation of this document is prohibited without the express written permission of SICK AG.

The trademarks stated in this document are the property of their respective owner.

© SICK AG. All rights reserved.

Original document

This document is an original document of SICK AG.



Contents

| | | |
|----------|---|-----------|
| 1 | About this document..... | 5 |
| 1.1 | Purpose of this document..... | 5 |
| 1.2 | Scope..... | 5 |
| 1.3 | Target groups of these operating instructions..... | 5 |
| 1.4 | Additional information..... | 5 |
| 1.5 | Symbols and document conventions..... | 5 |
| 2 | Safety information..... | 7 |
| 2.1 | General safety notes..... | 7 |
| 2.2 | Intended use..... | 7 |
| 2.3 | Inappropriate use..... | 8 |
| 2.4 | Requirements for the qualification of personnel..... | 8 |
| 3 | Product description..... | 9 |
| 3.1 | Device overview..... | 9 |
| 3.2 | Structure and function..... | 9 |
| 3.3 | Product characteristics..... | 9 |
| 3.3.1 | Interfaces..... | 9 |
| 3.3.2 | Compatible sensor types..... | 10 |
| 3.3.3 | Restart interlock..... | 10 |
| 3.3.4 | External device monitoring..... | 10 |
| 3.3.5 | Status indicators..... | 10 |
| 4 | Project planning..... | 12 |
| 4.1 | Manufacturer of the machine..... | 12 |
| 4.2 | Operating entity of the machine..... | 12 |
| 4.3 | Design..... | 12 |
| 4.4 | Electrical integration..... | 13 |
| 4.4.1 | Voltage supply..... | 13 |
| 4.4.2 | Enabling current paths..... | 14 |
| 4.4.3 | Application diagnostic output..... | 14 |
| 4.4.4 | Restart interlock..... | 15 |
| 4.4.5 | External device monitoring (EDM)..... | 15 |
| 4.4.6 | Connection diagrams..... | 16 |
| 4.5 | Testing plan..... | 17 |
| 4.5.1 | Planning the thorough check during commissioning and in certain situations..... | 17 |
| 4.5.2 | Planning the regular thorough check..... | 17 |
| 5 | Mounting..... | 19 |
| 5.1 | Mounting procedure..... | 19 |
| 5.2 | Disassembly..... | 20 |
| 5.3 | Module exchange..... | 20 |
| 6 | Electrical installation..... | 22 |

| | | |
|-----------|---|-----------|
| 6.1 | Device connection..... | 22 |
| 7 | Commissioning..... | 25 |
| 7.1 | Safety..... | 25 |
| 7.2 | Check during commissioning and modifications..... | 25 |
| 8 | Troubleshooting..... | 26 |
| 8.1 | Safety..... | 26 |
| 8.2 | Status indicator (LED)..... | 26 |
| 9 | Decommissioning..... | 27 |
| 9.1 | Disposal..... | 27 |
| 10 | Technical data..... | 28 |
| 10.1 | Data sheet..... | 28 |
| 10.2 | Dimensional drawings..... | 33 |
| 10.3 | Internal circuitry..... | 34 |
| 11 | Ordering information..... | 35 |
| 11.1 | Ordering information for ReLy..... | 35 |
| 12 | Annex..... | 36 |
| 12.1 | Conformities and certificates..... | 36 |
| 12.1.1 | EU declaration of conformity..... | 36 |
| 13 | List of figures..... | 37 |
| 14 | List of tables..... | 38 |

1 About this document

1.1 Purpose of this document

These operating instructions contain the information required during the life cycle of the safety relay.

These operating instructions must be made available to everyone who works with the safety relay.

1.2 Scope

Product

This document applies to the following products:

- Product code: ReLy OSSD3
- “Operating instructions” type label entry: 8023912

Document identification

Document part number:

- This document: 8023925
- Available language versions of this document: 8023912

You can find the current version of all documents at www.sick.com.

1.3 Target groups of these operating instructions

Some sections of these operating instructions are intended for certain target groups. However, the entire operating instructions are relevant for intended use of the product.

Table 1: Target groups and selected sections of these operating instructions

| Target group | Sections of these operating instructions |
|--|--|
| Project developers (planners, developers, designers) | "Project planning", page 12 "Technical data", page 28 |
| Installers | "Mounting", page 19 |
| Electricians | "Electrical installation", page 22 |
| Safety experts (such as CE authorized representatives, compliance officers, people who test and approve the application) | "Project planning", page 12 "Commissioning", page 25 "Technical data", page 28 |
| Operators | "Troubleshooting", page 26 |
| Maintenance personnel | "Troubleshooting", page 26 |

1.4 Additional information

www.sick.com

The following information is available on the Internet:

- Data sheets and application examples
- CAD data and dimensional drawings
- Certificates (e.g. EU declaration of conformity)
- Guide for Safe Machinery Six steps to a safe machine

1.5 Symbols and document conventions

The following symbols and conventions are used in this document:

Safety notes and other notes



DANGER

Indicates a situation presenting imminent danger, which will lead to death or serious injuries if not prevented.



WARNING

Indicates a situation presenting possible danger, which may lead to death or serious injuries if not prevented.



CAUTION

Indicates a situation presenting possible danger, which may lead to moderate or minor injuries if not prevented.



NOTICE

Indicates a situation presenting possible danger, which may lead to property damage if not prevented.



NOTE

Indicates useful tips and recommendations.

Instructions to action

- ▶ The arrow denotes instructions to action.
- 1. The sequence of instructions for action is numbered.
- 2. Follow the order in which the numbered instructions are given.
- ✓ The check mark denotes the result of an instruction.

LED symbols

These symbols indicate the status of an LED:

- The LED is off.
- ◐ The LED is flashing.
- The LED is illuminated continuously.

2 Safety information

2.1 General safety notes

Product integration



DANGER

The product can not offer the expected protection if it is integrated incorrectly.

- ▶ Plan the integration of the product in accordance with the machine requirements (project planning).
 - ▶ Implement the integration of the product in accordance with the project planning.
-

Mounting and electrical installation



DANGER

Death or severe injury due to electrical voltage and/or an unexpected startup of the machine

- ▶ Make sure that the machine is (and remains) disconnected from the voltage supply during mounting and electrical installation.
 - ▶ Make sure that the dangerous state of the machine is and remains switched off.
-

Repairs and modifications



DANGER

Improper work on the product

A modified product may not offer the expected protection if it is integrated incorrectly.

- ▶ Apart from the procedures described in this document, do not repair, open, manipulate or otherwise modify the product.
-

2.2 Intended use

The safety relay is an evaluation unit device for switching safety-related circuits on and off for the following sensor types:

- Safety sensors with monitored semiconductor output (OSSD)

The safety relay complies with class A, group 1 as per EN 55011. Group 1 encompasses all ISM devices in which intentionally generated and/or used conductor-bound RF energy that is required for the inner function of the device itself occurs.

The product may be used in safety functions.

The product must only be used within the limits of the prescribed and specified technical specifications and operating conditions at all times.

Incorrect use, improper modification or manipulation of the product will invalidate any warranty from SICK; in addition, any responsibility and liability of SICK for damage and secondary damage caused by this is excluded.

UL/CSA applications

If the product is being used in accordance with UL 508 or CSA C22.2 No. 14, the following conditions must also be met:

- To protect the device's 24-volt voltage supply, use a fuse with a maximum voltage of 4 A and a minimum of 30 V DC in accordance with UL 248.



NOTE

The safety functions have not be evaluated by UL. Authorization is in accordance with UL 508, general applications.

2.3 Inappropriate use

The safety relay is **not** suitable for the following applications (this list is not exhaustive):

- At altitudes of over 4,000 m above sea level
- In explosion-hazardous areas

2.4 Requirements for the qualification of personnel

The product must be configured, installed, connected, commissioned, and serviced by qualified safety personnel only.

Project planning

You need safety expertise to implement safety functions and select suitable products for that purpose. You need expert knowledge of the applicable standards and regulations.

Mounting, electrical installation and commissioning

You need suitable expertise and experience. You must be able to assess if the machine is operating safely.

Operation and maintenance

You need suitable expertise and experience. You must be instructed in machine operation by the machine operator. For maintenance, you must be able to assess if the machine is operating safely.

3 Product description

3.1 Device overview

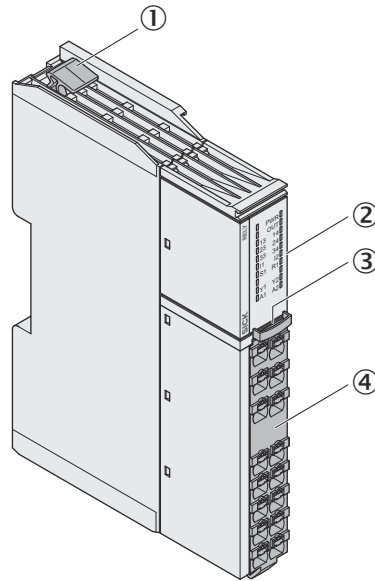

Figure 1: Device overview

- ① Device unlocking
- ② LEDs
- ③ Front connector unlocking
- ④ Front connector

3.2 Structure and function

The safety relay ReLy OSSD3 is an electrical switching device with inputs and outputs.

The safety capable inputs of the safety relay are connected to safety sensors or safety switches.

2 safety capable inputs control the internal relays, which are used to reliably switch the enabling current paths.

The enabling current paths close only when the two safety capable inputs close within 3 s of one another.

At the enabling current paths it is possible to connect, for example, actuators with positively guided contacts.

3.3 Product characteristics

3.3.1 Interfaces

Inputs

- 2 safety capable inputs
- Input for reset pushbutton or external device monitoring

Outputs

- 3 enabling current paths (safe)
- 2 application diagnostic outputs (not safe)
- 1 Test output (not safe)

3.3.2 Compatible sensor types

Table 2: Compatible sensor types

| Sensor type | Description | Examples |
|---|--|---|
| Safety sensors with monitored semiconductor output (OSSD) | Safety sensors with dual-channel cross-circuit monitored semiconductor outputs | <ul style="list-style-type: none"> • Transponder safety switch e.g., Sistra • Safety light curtains, e.g. deTec4 • Safety laser scanner, e.g., microScan3, nanoScan3 |

3.3.3 Restart interlock

A restart interlock can be implemented with a reset pushbutton.

3.3.4 External device monitoring

Permanent external device monitoring can be implemented using external wiring.

3.3.5 Status indicators

LEDs

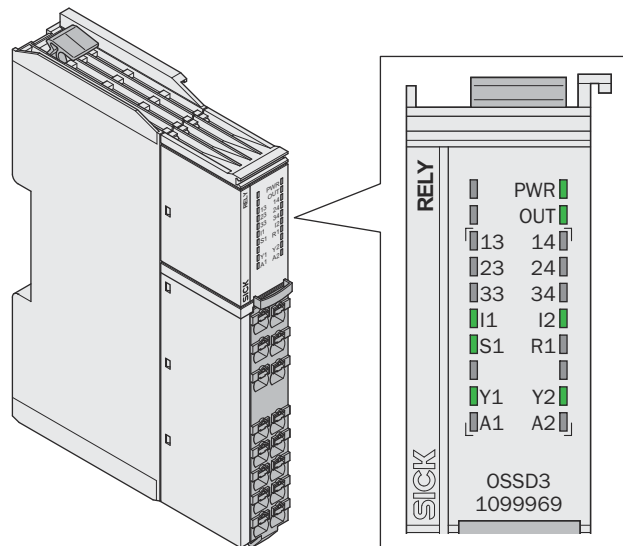

Figure 2: LEDs

The labeled positions are only partially assigned LEDs. The positions and their labels (except the top 2 lines) also indicate the assignment of the terminals on the front connector.

Table 3: Safety relay indicators

| Labeling | Color | Function |
|----------|-----------|--|
| PWR | Green/Red | Voltage supply |
| OUT | Green | Enabling current paths |
| I1 | Green | Safety input |
| I2 | Green | Safety input |
| S1 | Green | Reset pushbutton input, external device monitoring (EDM) |
| Y1 | Green | Application diagnostic output (NC) |

| Labeling | Color | Function |
|----------|-------|--|
| Y2 | Green | Application diagnostic output (reset required) |

Further topics

- ["Status indicator \(LED\)", page 26](#)

4 Project planning

4.1 Manufacturer of the machine

The manufacturer of the machinery must carry out a risk assessment and apply appropriate protective measures. Further protective measures may be required in addition to the product.

The product must not be tampered with or changed, except for the procedures described in this document.

The product must only be repaired by the manufacturer of the product or by someone authorized by the manufacturer. Improper repair can result in the product not providing the expected protection.

4.2 Operating entity of the machine

Changes to the electrical integration of the product in the machine controller and changes to the mechanical mounting of the product necessitate a new risk assessment. The results of this risk assessment may require the entity operating the machine to meet the obligations of a manufacturer.

After each change to the configuration, it is necessary to check whether the protective measure provides the necessary protection. The person making the change is responsible for ensuring that the protection measure provides the necessary protection.

The product must not be tampered with or changed, except for the procedures described in this document.

The product must only be repaired by the manufacturer of the product or by someone authorized by the manufacturer. Improper repair can result in the product not providing the expected protection.

4.3 Design

Installation site

The safety relay must be installed in a control cabinet with an enclosure rating of IP54 or higher.

The safety relay must be installed on a mounting rail (35 mm) in accordance with IEC 60715.

Space requirements in the control cabinet

To ensure sufficient air circulation and cooling, sufficient distance must be kept in the control cabinet above and below the safety relay.

Sufficient distance must be kept for the connected cables before the module (front side).

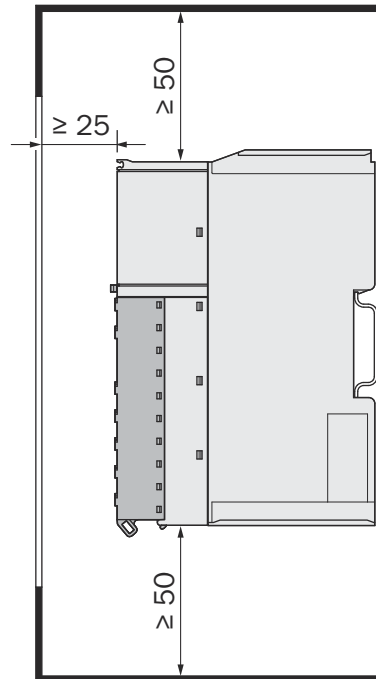

Figure 3: Distances in control cabinet

Required distance:

- Above and below the module: ≥ 50 mm
- In front of the module: ≥ 25 mm

4.4 Electrical integration

Important information



DANGER

Hazard due to lack of effectiveness of the protective device

In the case of non-compliance, it is possible that the dangerous state of the machine may not be stopped or not stopped in a timely manner.

- ▶ Ensure the safety relay is supplied with supply voltage in all operating statuses.
- ▶ Ensure that the supply voltage of the safety relay is not connected via safety sensors or safety switches in order to switch the enabling current paths.

4.4.1 Voltage supply

Prerequisites

- The power supply unit is able to jumper a brief power failure of 20 ms as specified in IEC 60204-1.
- The voltage supply and connected signals meet the requirements for SELV/PELV (EN 61140) or NEC Class 2 (UL 1310).
- The electrical voltage supply has a suitable electrical fuse.

Further topics

- ["Data sheet", page 28](#)

4.4.2 Enabling current paths

Important information



DANGER

Hazard due to lack of effectiveness of the protective device

- ▶ Ensure the enabling current paths are supplied by the same voltage supply.

Cross-circuits

Cross-circuits between the enabling current paths or with other signals may not be detected and can put the machine in a dangerous state.

Measures:

- ▶ Lay the cables in a protected manner or separately (e.g., within the control cabinet as per IEC 60204-1).
- ▶ Take other necessary measures to achieve the required safety-related characteristic values.

4.4.3 Application diagnostic output

Application diagnostic output Y1

The signal of the Y1 application diagnostic output changes as soon as the enabling current paths switch. The application diagnostic output is not safe.

Application diagnostic output Y1 is based on the push-pull principle, meaning it can both absorb and apply current.

Table 4: Switching behavior of application diagnostic output Y1

| State of enabling current paths | State of application diagnostic output Y1 |
|---------------------------------|---|
| Closed | LOW (NPN) |
| Open | HIGH (PNP) |

Application diagnostic output Y2

Application diagnostic output Y2 outputs the “Reset required” signal with a frequency of 1 Hz, e.g. for the connection of a signal lamp.

Application diagnostic output Y2 is based on the push-pull principle, meaning it can both absorb and apply current.

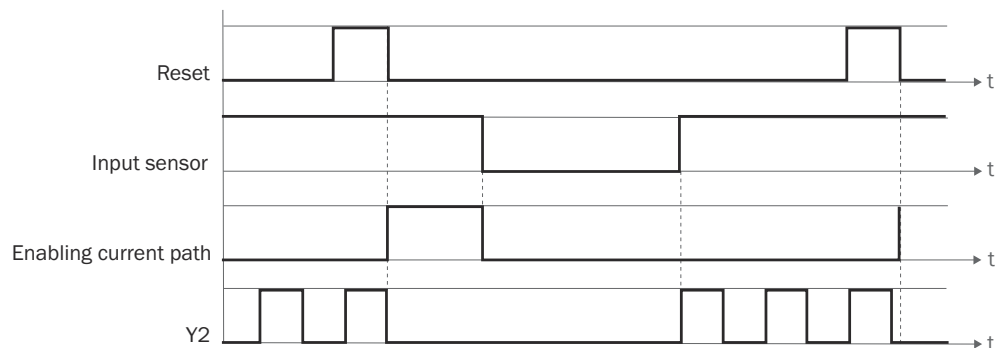

Figure 4: Sequence/timing diagram

4.4.4 Restart interlock

Important information



DANGER

Hazard due to unexpected starting of the machine
Death or severe injury

- ▶ If you connect the safety relay to an emergency stop pushbutton, you must use the restart interlock.
-

Restart interlock

A reset pushbutton must be connected to allow the restart interlock to be used. The reset pushbutton must be attached outside of the hazardous area. It must not be possible to access the reset pushbutton from inside the hazardous area. The entire hazardous area must be highly visible for all operators from the reset pushbutton.

Further topics

- ["Device connection", page 22](#)

4.4.5 External device monitoring (EDM)

External device monitoring (EDM)

With static external device monitoring, the safety relay tests whether the controlled actuators (contactors) have dropped out just before energizing the internal relay.

Cross-circuits

Cross-circuits within the external device monitoring (EDM) itself (e.g., before and after the contactor being monitored) or with other signals may not be detected and can put the machine in a dangerous state.

Measures:

- ▶ Lay the cables in a protected manner or separately (e.g., within the control cabinet as per IEC 60204-1).
- ▶ Take other necessary measures to achieve the required safety-related characteristic values.

Further topics

- ["Device connection", page 22](#)

4.4.6 Connection diagrams

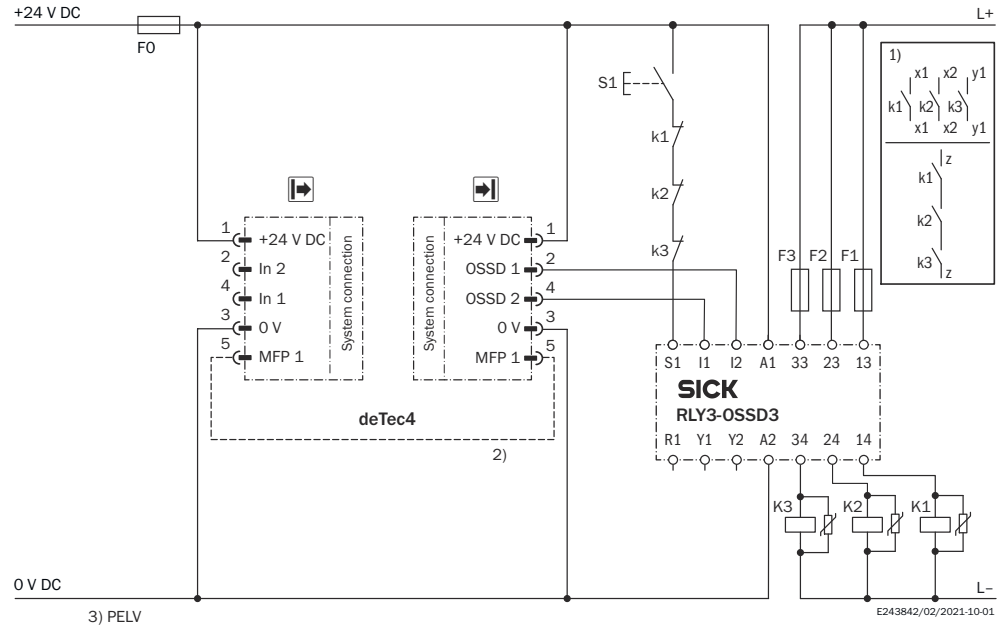

Figure 5: ReLy OSSD3 connection diagram, with restart interlock and external device monitoring (EDM)

- 1) Output circuits: These contacts must be incorporated into the control such that the dangerous state is brought to an end if the output circuit is open. For categories 4 and 3, they must be incorporated on dual-channels (x, y paths). Type 2 devices are suitable for use up to PL c. Single-channel incorporation into the control (z path) is only possible with a single-channel control and taking the risk analysis into account.
- 2) To indicate the status on both sides, the MFP 1 connections from the sender and receiver must be connected to each other in the control cabinet (optional)
- 3) SELV/PELV safety extra-low voltage.

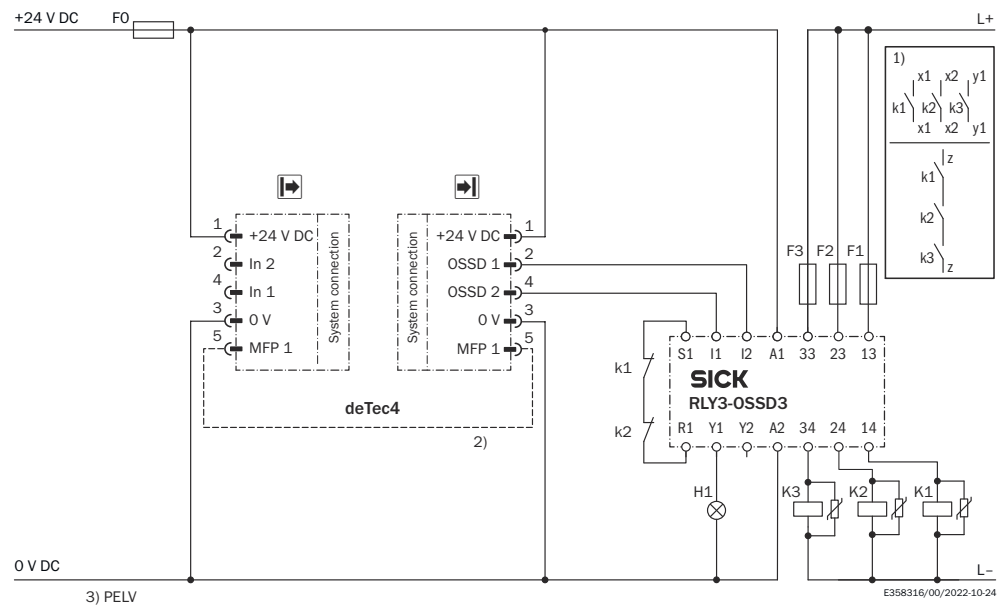

Figure 6: ReLy OSSD3 connection diagram, without restart interlock, with external device monitoring (EDM)

- 1) Output circuits: These contacts must be incorporated into the control such that the dangerous state is brought to an end if the output circuit is open. For categories 4 and 3, they must be incorporated on dual-channels (x, y paths). Type 2 devices are suitable for use up to PL c. Single-channel incorporation into the control (z path) is only possible with a single-channel control and taking the risk analysis into account.
- 2) To indicate the status on both sides, the MFP 1 connections from the sender and receiver must be connected to each other in the control cabinet (optional)
- 3) SELV/PELV safety extra-low voltage.

4.5 Testing plan

The manufacturer of the machine and the operating entity must define all required thorough checks. The definition must be based on the application conditions and the risk assessment and must be documented in a traceable manner.

The following tests must be planned:

- A thorough check must be carried out during commissioning and following modifications.
- The regular tests of the device must fulfill certain minimum requirements.

4.5.1 Planning the thorough check during commissioning and in certain situations

Overview

Before commissioning the machine and after making changes, you must check whether the safety functions are fulfilling their planned purpose and whether persons are being adequately protected.

Minimum requirements

The device and its application must be thoroughly checked in the following situations:

- Before commissioning
- After changes to the configuration or the safety function
- After changes to the mounting or the electrical installation
- After exceptional events, such as after manipulation has been detected, after modification of the machine, or after replacing components

The thorough check ensures the following:

- All relevant regulations are complied with and the device is effective in all of the machine's operating modes.
- The documentation accurately reflects the state/condition of the machine, including the protective device.

The thorough checks must be carried out by qualified safety personnel or specially qualified and authorized personnel, and must be documented in a traceable manner.

4.5.2 Planning the regular thorough check

Overview

The purpose of regular tests is to identify any defects due to changes or external influences (e.g. damage or manipulation) and to ensure that the protective measure provides the necessary protection.

Minimum requirements

The following thorough checks must be carried out at regular intervals:

- Thorough check of the housing for damage
- Thorough check of the cables for damage
- Check the device for signs of misuse or manipulation
- Thorough check of the safety function

The required interval for performing these thorough checks depends on the applicable safety capability of the overall application, [see table 7, page 28](#).

5 Mounting

5.1 Mounting procedure

Prerequisites

- Mounting is done in accordance with EN 50274 and electrical installation in accordance with IEC 60204-1 in the control cabinet with enclosure rating IP54.
- Mounting must be done on a non-flammable base.
- Mounting is done on a 35 mm mounting rail (IEC 60715).
- The mounting rail is connected to the functional earth.
- The module is installed with a vertical orientation (on a horizontal mounting rail).
- There is at least 50 mm of space for air circulation above and below the module.
- There is at least 25 mm of space in front of the module (front side). More space may be needed depending on the connections.

Approach

1. Attach module to mounting rail.

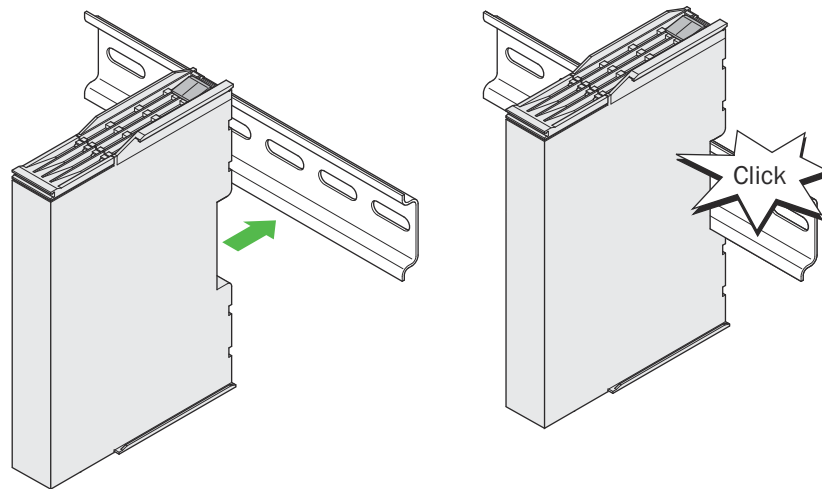

Figure 7: Mounting

- ✓ The module engages with an audible click.
2. Attach the end clamps on the mounting rail on the left and right of the module.

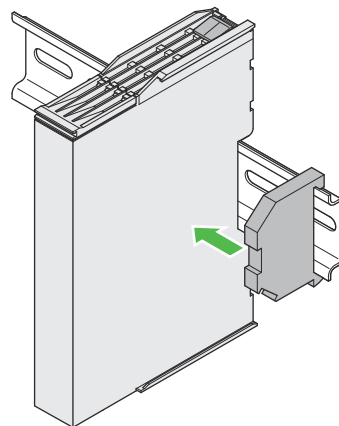

Figure 8: Mounting the end clamps

5.2 Disassembly

Prerequisites

- Electrician screwdriver (slotted screwdriver)

Approach

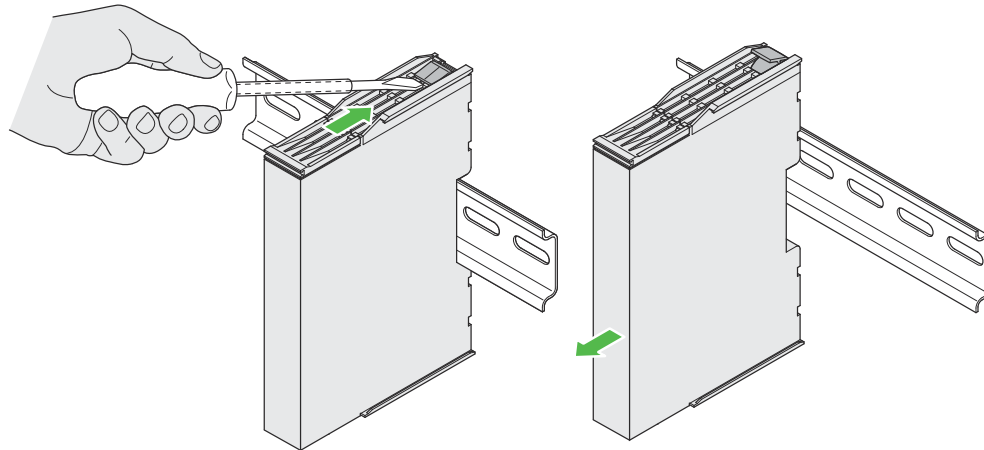

Figure 9: Disassembly

1. Press the unlocking mechanism on the upper side of the module towards the back using the electrician screwdriver.
2. Loosen module from the mounting rail.

5.3 Module exchange

Approach

1. Disconnect module and the connected components from all voltage sources.
2. Take front connector with connected cables off the defective device: Press the unlocking mechanism of the front connector downwards and pull out the front connector.

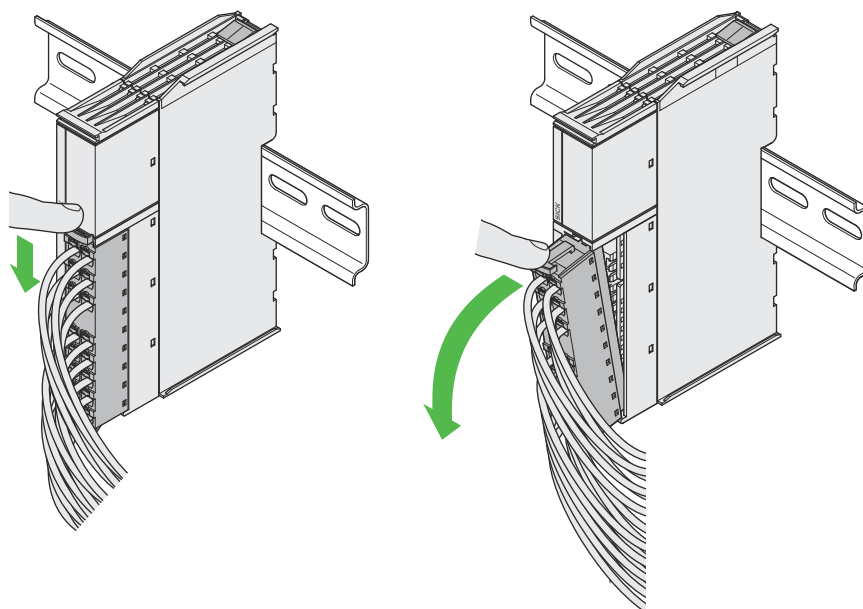

Figure 10: Removing the plug

3. Dismantle the defective module.
4. Mount new module.
5. Mount front connector with connected cables to the new module: First mount in the module with bent hook and then engage in the housing.

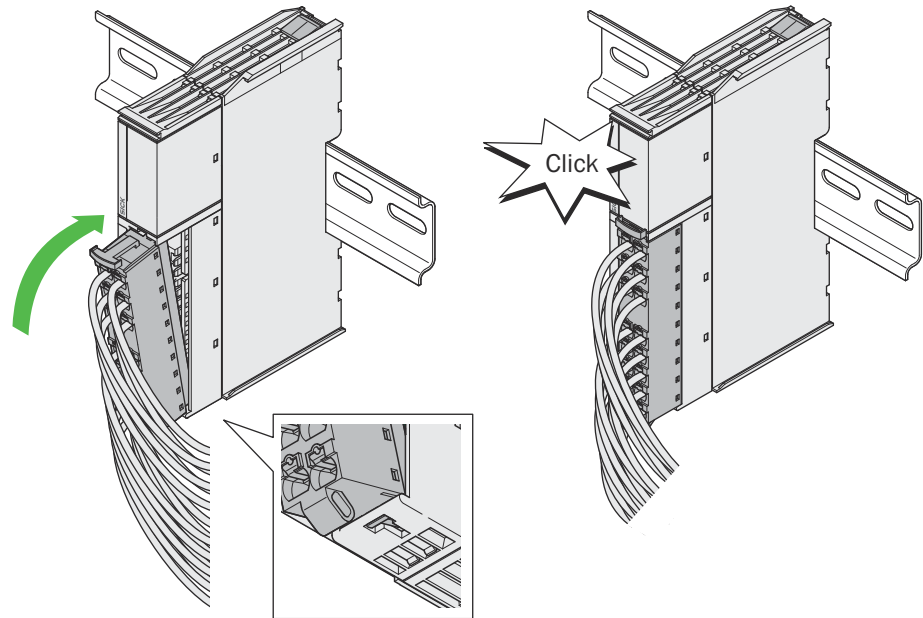

Figure 11: Mount the front connector

- ✓ The front connector engages with an audible click.

6 Electrical installation

6.1 Device connection

Important information



DANGER

Hazard due to lack of effectiveness of the protective device

In the case of non-compliance, it is possible that the dangerous state of the machine may not be stopped or not stopped in a timely manner.

- ▶ Ensure the safety relay is supplied with supply voltage in all operating statuses.
 - ▶ Ensure that the supply voltage of the safety relay is not connected via safety sensors or safety switches in order to switch the enabling current paths.
-

Prerequisites

- Electrical installation is carried out according to the project planning.
- Dangerous condition of the machine is and remains off during the electrical installation.
- Electrical installation is done in conformity with IEC 60204-1.
- The mounting rail is connected to the functional earth.
- The safety outputs and external device monitoring (EDM) must be wired within the control cabinet.
- When using the safety relay with voltages larger than the safety extra-low voltage: The N/C contacts of the controlled contactors must be safely isolated from the other contactor contacts.
- Enabling current paths are safely isolated from the other terminals. There is a basic insulation between the enabling current paths.
- The ground connection of all connected devices must have the same potential as A2.
- All connected devices and the reset pushbutton comply with the required category in accordance with ISO 13849-1 and SIL in accordance with IEC 62061 (e.g. shielded single sheathed cables, separate installation).

Pin assignment

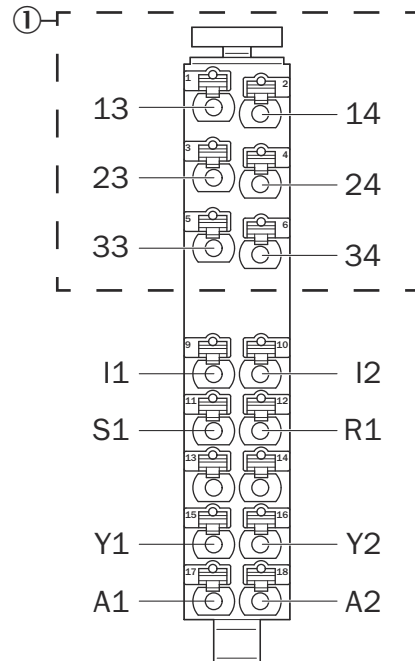

Figure 12: Terminals on front connector

- ① Safe isolation of the enabling current paths from the other terminals

Table 5: Pin assignment of the terminals

| Terminal | Description |
|------------------|--|
| 13, 14 | Enabling current path |
| 23, 24 | Enabling current path |
| 33, 34 | Enabling current path |
| I1 ¹⁾ | Safety input |
| I2 ¹⁾ | Safety input |
| S1 ²⁾ | Reset pushbutton input, external device monitoring (EDM) |
| R1 | Test output |
| Y1 | Application diagnostic output (NC) |
| Y2 | Application diagnostic output (reset required) |
| A1 | 24 V DC voltage supply |
| A2 | Voltage supply 0 V DC |

¹⁾ For a single-channel base device, connect a jumper between I1 and I2.

- ²⁾
- Use with restart interlock, with external device monitoring (EDM): Connect the N/C contacts of the actuators between voltage supply U_v , the N/O contact of the reset pushbutton and S1.
 - Use with restart interlock, without external device monitoring (EDM): Connect the N/O contact of the reset pushbutton between S1 and voltage supply U_v .
 - Use without restart interlock, with external device monitoring (EDM): Connect the N/C contacts of the actuators between R1 and S1.
 - Use without restart interlock, without external device monitoring (EDM): Connect R1 and S1 with a wire jumper.

Complementary information

To protect and increase the service life of contact outputs, equip all connected loads with varistors or RC elements. The response times will increase depending on the suppressor used.

Further topics

- ["Connection diagrams", page 16](#)
- ["Data sheet", page 28](#)
- ["Electrical integration", page 13](#)

7 Commissioning

7.1 Safety

**DANGER**

Dangerous state of the machine

During commissioning, the machine or the protective device may not yet behave as you have planned.

- ▶ Make sure that there is no-one in the hazardous area during commissioning.
-

7.2 Check during commissioning and modifications

The thorough check is intended to ensure that the safety functions are fulfilling their planned purpose and whether persons are being adequately protected.

- ▶ Carry out the checks specified in the test plan of the manufacturer of the machine and the operating entity.

8 Troubleshooting

8.1 Safety



DANGER

Hazard due to lack of effectiveness of the protective device

In the case of non-compliance, it is possible that the dangerous state of the machine may not be stopped or not stopped in a timely manner.

- ▶ Immediately shut the machine down if the behavior of the machine cannot be clearly identified.
- ▶ If a machine fault cannot be definitively determined or safely rectified, immediately shut the machine down.
- ▶ Secure the machine so that it cannot switch on unintentionally.



NOTE

Additional information on troubleshooting can be found at the responsible SICK subsidiary.

8.2 Status indicator (LED)

Status indicator (LED)

Table 6: Fault indicators and operational statuses

| LED | Status | Possible cause |
|-----------|-----------------------|---|
| PWR | ○ | No supply voltage |
| All LEDs | ◐ All colors | Initialization with LED test |
| PWR | ● Green | No fault |
| PWR | ◐ Red | <ul style="list-style-type: none"> • Supply voltage too low temporarily or permanently • Internal error |
| PWR | ◐ Red/green | Error Additional LEDs flash for accurate diagnosis. |
| OUT | ○ | Enabling current paths open |
| OUT | ● Green | Enabling current paths closed |
| OUT | ◐ green (1 Hz) | Error in enabling current path |
| S1 | ◐ Green | When using without restart interlock: Input error (e.g. stuck at HIGH) |
| S1 | ● Green | Reset pushbutton actuated, N/C contact of the actuator closed |
| I1 and I2 | ◐ Green, alternate | Input error: discrepancy time expired |
| I1 and I2 | ◐ Green, simultaneous | Input error: cross-circuit, process error |
| Y1 | ○ | Enabling current paths closed |
| Y1 | ● Green | Enabling current paths open |
| Y2 | ○ | Output with LOW status |
| Y2 | ◐ Green | Reset required |
| Y2 | ● Green | Reset pushbutton actuated |

9 Decommissioning

9.1 Disposal

Approach

- ▶ Always dispose of unusable devices in accordance with national waste disposal regulations.



Complementary information

SICK will be glad to help you dispose of these devices on request.

10 Technical data

10.1 Data sheet

Safety-related parameters

The required safety-related characteristic value depends on the application.

Table 7: Safety-related parameters

| | | | |
|---|---|------------------------|----------------------|
| Safety integrity level (IEC 61508) | SIL 3 | SIL 2 | SIL 1 |
| SIL claim limit (IEC 62061) | SIL 3 | SIL 2 | SIL 1 |
| Category (ISO 13849-1) | 4 | 3 | 3 |
| Performance level (ISO 13849-1) | PL e | PL d | PL c |
| Hardware error tolerance | 1 | | |
| Maximum test interval of the safety function | 1 month | 1 year | - |
| MTTF _D (single channel) (ISO 13849-1) ¹⁾ | 300 years | 100 years | 100 years |
| PFH _D (mean probability of a dangerous failure per hour) ¹⁾ | | | |
| For operating heights ≤ 2,000 m above sea level | 1 × 10 ⁻⁹ | 1 × 10 ⁻⁸ | 1 × 10 ⁻⁷ |
| For operating heights 2,000... 4,000 m above sea level | 5 × 10 ⁻⁹ | 5 × 10 ⁻⁸ | 1 × 10 ⁻⁷ |
| PFD _{avg} (mean probability of a dangerous failure on demand) | | | |
| For operating heights ≤ 2,000 m above sea level | 5 × 10 ⁻⁵ | 5 × 10 ⁻⁴ | 5 × 10 ⁻³ |
| For operating heights 2,000... 4,000 m above sea level | 2.5 × 10 ⁻⁴ | 2.5 × 10 ⁻³ | 5 × 10 ⁻³ |
| T _M (mission time) | 20 years (ISO 13849-1) | | |
| Safe status when a fault occurs | The normally open is open; in other words, the safety-related enabling current paths are interrupted. | | |
| Stop category | 0 (IEC 60204-1) | | |

¹⁾ To achieve the safety-related characteristic values, the service life curve of the safety contacts must be taken into consideration.
 The maximum number of switching operations should be applied to the mission time T_M.
 Mean number of switching operations per year = switching operations based on the service life curve/T_M
 As long as the mean number of allowed switching operations per year and the number of allowed switching operations during the mission time T_M has not been reached, the safety-related characteristic values do not depend on the switching frequency if the service life curve is adhered to. B10_d has already been taken into consideration when calculating the safety-related characteristic values.
 Service life curve, [see figure 14, page 33](#)

Mechanical data

Table 8: Mechanical data

| | |
|---|---|
| Weight | 150 g |
| Mounting | Mounting rail (IEC 60715) |
| Connection type | Spring terminals |
| Stripping length | 8 mm |
| Wire cross-section | |
| Single wire (1×) | 0.14 mm ² ... 1.5 mm ² |
| Fine wire (1×) | 0.14 mm ² ... 1.5 mm ² |
| Fine wire with ferrules (2 ×, same cross-section) with TWIN ferrule with plastic collar | ≤ 0.5 mm ² |
| Fine wire with ferrules with or without collar (1×) | 0.25 mm ² ... 1.0 mm ² |
| For UL and CSA applications | 26 AWG ... 14 AWG Use copper conductors only min. rated for 85 °C. |

Electrical data

Table 9: Operating data

| | |
|---|--|
| Supply voltage V_S | 24 V DC (16.8 V DC ... 30 V DC) (safety extra-low voltage) ¹⁾ |
| Rated voltage | +24 V DC |
| Residual ripple U_{SS} | 2.4 V |
| Power consumption | ≤ 2.5 W |
| Short-circuit protection | Max. 4 A Safety fuse with triggering characteristic: slow-blow UL/CSA applications: UL-listed fuse according to UL 248-14 required |
| Power-up delay after supply voltage applied | ≤ 5 s |

- ¹⁾ The external voltage supply must be capable of bridging a brief power failure of 20 ms as specified in IEC 60204-1. Suitable power supply units are available as accessories from SICK.
Protect supply voltage against short-circuit.

Table 10: Inputs (I1, I2, S1)

| | |
|--------------------------------|-------------------------------|
| Input voltage HIGH | 24 V DC (11 V DC ... 30 V DC) |
| Input voltage LOW | 0 V DC (-3 V DC ... 5 V DC) |
| Input capacitance | ≤ 15 nF |
| Input current | 4 mA ... 6 mA |
| Reset time | |
| Manual | ≤ 250 ms |
| Automatic | ≤ 250 ms |
| Actuation time of reset button | 140 ms ... 30 s |
| Test pulse width | ≤ 1,000 μs |
| Test pulse rate | ≤ 10 Hz |
| Concurrence monitoring | ≤ 3,000 ms |

| | |
|--------------------------|---------|
| Length of cable (single) | ≤ 100 m |
|--------------------------|---------|

Table 11: Test pulse output (R1)

| | |
|--------------------------|---|
| Type of output | PNP semiconductor output, short-circuit protected |
| Output voltage | ($U_V - 3\text{ V}$) ... U_V |
| Test pulse interval | 40 ms |
| Test pulse width | 2 ms |
| Length of cable (single) | ≤ 100 m |
| Conductor resistance | ≤ 10 Ω |

Table 12: Application diagnostic output (Y1, Y2)

| | |
|----------------------|---|
| Type of output | Push-pull semiconductor output, short-circuit protected |
| Output voltage HIGH | ($U_V - 3\text{ V}$) ... U_V |
| Output voltage LOW | 0 V ... 3 V |
| Input current (NPN) | ≤ 15 mA |
| Output current (PNP) | ≤ 120 mA |

Table 13: Enabling current path (13/14, 23/24, 33/34)

| | |
|--|---|
| Response time (opening of enabling current paths) | ≤ 12 ms |
| Number of enabling current paths (normally open, safe) | 3 |
| Contact type | Positively guided |
| Contact material | Silver alloy, gold flash plated |
| Switching voltage | |
| At altitudes below 2,000 m above sea level | 10 V DC ... 250 V DC 10 V AC ... 250 V AC |
| At altitudes 2,000 m above sea level ... 4,000 m above sea level | 10 V DC ... 150 V DC 10 V AC ... 150 V AC |
| Switching current | 10 mA ... 6 A see figure 13, page 32 see figure 14, page 33 |
| Sum current | ≤ 12 A |
| Utilization category | AC-15: 230 V, 5 A (IEC 60947-5-1) DC-13 (0.1 Hz): 24 V, 4 A (IEC 60947-5-1) |
| DC switching capacity | 0.1 W ... 200 W see figure 13, page 32 |
| AC switching capacity | 0.1 VA ... 1,500 VA |
| Switching frequency | ≤ 1 Hz |
| Mechanical service life | 10 × 10 ⁶ switching operations |
| Contact fuse with safety fuse gG or circuit breaker C | Max. 6 A |
| Max. short-circuit protection | ≤ 400 A |

Table 14: Insulation coordination – enabling current paths (13/14, 23/24, 33/34) to the 24 V circuit

| | |
|---|---|
| Type of insulation (IEC 60947-1) | Safe electrical separation |
| Degree of contamination | 2 |
| Air and creepage distances between the insulated circuits | ≥ 5.5 mm |
| Rated insulation voltage | |
| At altitudes up to 2,000 m above sea level | 250 V AC |
| At altitudes up to 2,000 m above sea level ... 4,000 m above sea level | 150 V AC with overvoltage category III 250 V AC with overvoltage category II |
| Rated impulse withstand voltage U_{imp} | |
| At altitudes up to 2,000 m above sea level | 6 kV |
| At altitudes up to 2,000 m above sea level ... 4,000 m above sea level | 4 kV |

Table 15: Insulation coordination – enabling current paths (13/14, 23/24, 33/34) amongst each other

| | |
|---|---|
| Type of insulation (IEC 60947-1) | Basic insulation |
| Degree of contamination | 2 |
| Air and creepage distances between the insulated circuits | ≥ 3 mm |
| Rated insulation voltage | |
| At altitudes up to 2,000 m above sea level | 250 V AC |
| At altitudes up to 2,000 m above sea level ... 4,000 m above sea level | 150 V AC with overvoltage category III 250 V AC with overvoltage category II |
| Rated impulse withstand voltage U_{imp} | |
| At altitudes up to 2,000 m above sea level | 4 kV |
| At altitudes up to 2,000 m above sea level ... 4,000 m above sea level | 2.5 kV |

Ambient data

Table 16: Ambient data

| | |
|---|--|
| Enclosure rating | IP20 (IEC 60529) ¹⁾ |
| Ambient operating temperature | |
| At altitudes up to 2,000 m above sea level (UL/CSA: surrounding air temperature) | -25 °C ... +55 °C |
| At altitudes 2,000 m above sea level ... 3,000 m above sea level | -25 °C ... +50 °C |
| At altitudes 3,000 m above sea level ... 4,000 m above sea level | -25 °C ... +45 °C |
| Storage temperature | -25 °C ... +70 °C |
| Operating altitude | Max. 4,000 m above sea level |
| Air humidity | 10% ... 95%, non-condensing for climatic conditions according to IEC 61131-2 |
| Emitted interference | According to IEC 61000-6-4 |

| | |
|--------------------------|--|
| | |
| Immunity to interference | According to IEC 61326-3-1 According to IEC 61000-6-2 According to IEC 60947-5-1 |

1) Prerequisite: The front plug is mounted.

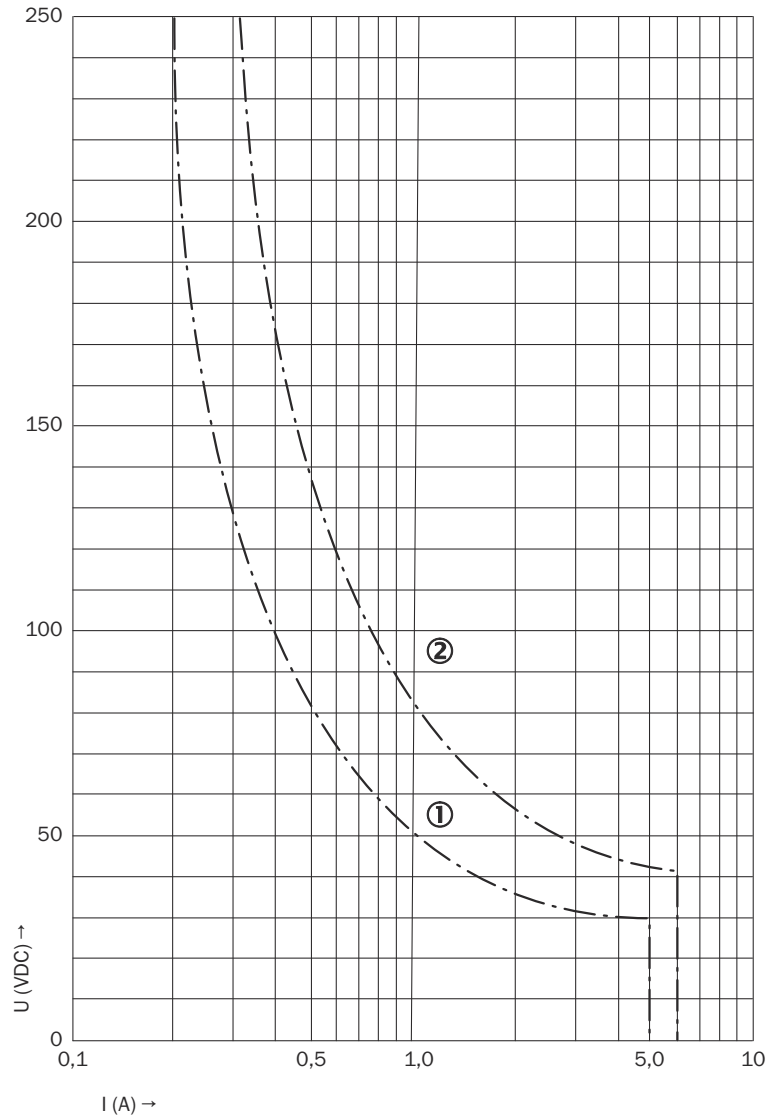

Figure 13: Breaking capacity without continuous arcing

- ① Inductive load L/R 40 ms
- ② Resistive load

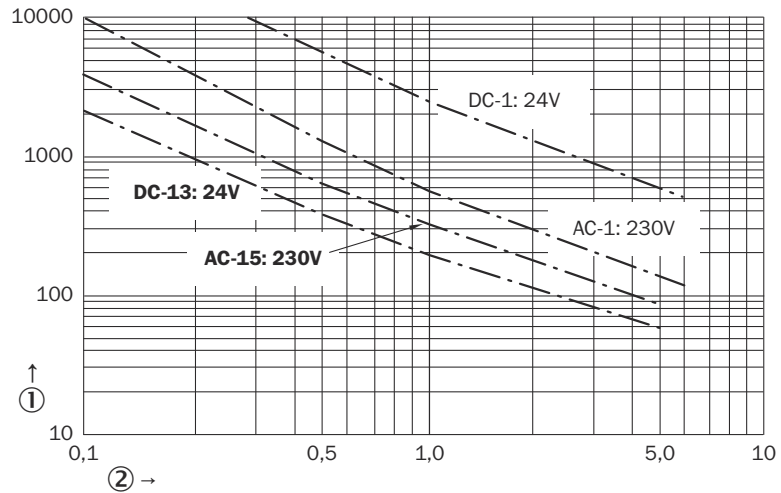

Figure 14: Electrical endurance of contacts 13/14, 23/24 and 33/34

- ① Switching operations × 1,000
- ② Switching current (A)

10.2 Dimensional drawings

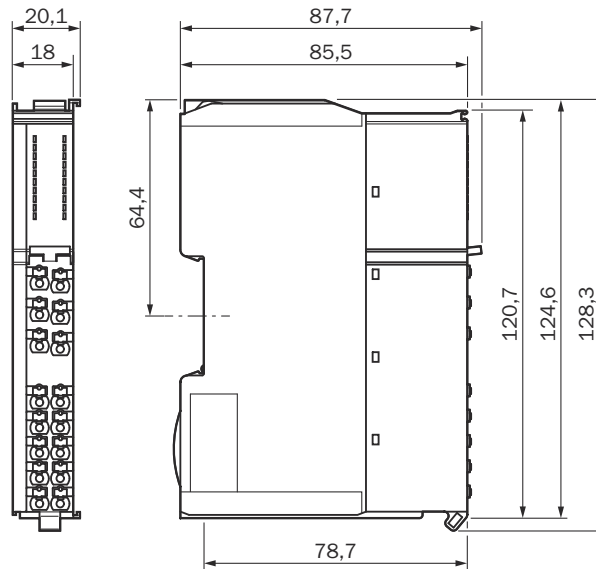

Figure 15: Dimensional drawing

10.3 Internal circuitry

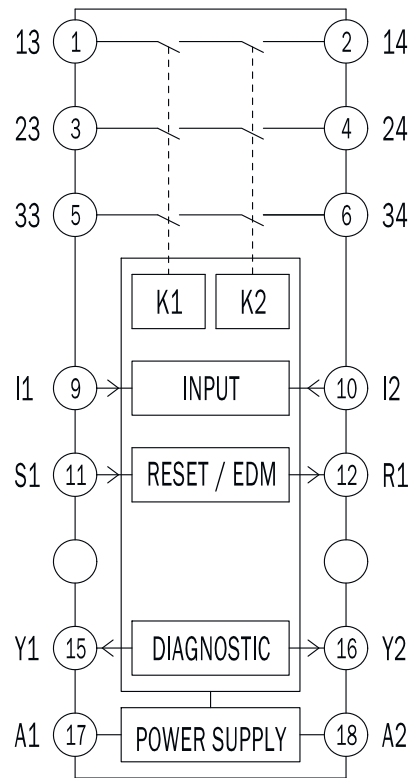

Figure 16: Internal circuitry

11 Ordering information

11.1 Ordering information for ReLy

Table 17: Ordering information

| Part | Usage | Type code | Part number |
|------------|--|--------------|-------------|
| ReLy OSSD3 | Opto-electronic protective devices, magnetic safety switches | RLY3-OSSD300 | 1099969 |

12 Annex

12.1 Conformities and certificates

You can obtain declarations of conformity, certificates, and the current operating instructions for the product at www.sick.com. To do so, enter the product part number in the search field (part number: see the entry in the “P/N” or “Ident. no.” field on the type label).

12.1.1 EU declaration of conformity

Excerpt

The undersigned, representing the manufacturer, herewith declares that the product is in conformity with the provisions of the following EU directive(s) (including all applicable amendments), and that the standards and/or technical specifications stated in the EU declaration of conformity have been used as a basis for this.

- ROHS DIRECTIVE 2011/65/EU
- EMC DIRECTIVE 2014/30/EU
- MACHINERY DIRECTIVE 2006/42/EC

13 List of figures

| | | |
|-----|--|----|
| 1. | Device overview..... | 9 |
| 2. | LEDs..... | 10 |
| 3. | Distances in control cabinet..... | 13 |
| 4. | Sequence/timing diagram..... | 14 |
| 5. | ReLy OSSD3 connection diagram, with restart interlock and external device monitoring (EDM)..... | 16 |
| 6. | ReLy OSSD3 connection diagram, without restart interlock, with external device monitoring (EDM)..... | 16 |
| 7. | Mounting..... | 19 |
| 8. | Mounting the end clamps..... | 19 |
| 9. | Disassembly..... | 20 |
| 10. | Removing the plug..... | 20 |
| 11. | Mount the front connector..... | 21 |
| 12. | Terminals on front connector..... | 23 |
| 13. | Breaking capacity without continuous arcing..... | 32 |
| 14. | Electrical endurance of contacts 13/14, 23/24 and 33/34..... | 33 |
| 15. | Dimensional drawing..... | 33 |
| 16. | Internal circuitry..... | 34 |

14 List of tables

- 1. Target groups and selected sections of these operating instructions.....5
- 2. Compatible sensor types.....10
- 3. Safety relay indicators..... 10
- 4. Switching behavior of application diagnostic output Y1..... 14
- 5. Pin assignment of the terminals.....23
- 6. Fault indicators and operational statuses..... 26
- 7. Safety-related parameters..... 28
- 8. Mechanical data..... 29
- 9. Operating data..... 29
- 10. Inputs (I1, I2, S1)..... 29
- 11. Test pulse output (R1)..... 30
- 12. Application diagnostic output (Y1, Y2)..... 30
- 13. Enabling current path (13/14, 23/24, 33/34)..... 30
- 14. Insulation coordination – enabling current paths (13/14, 23/24, 33/34) to the 24 V circuit..... 31
- 15. Insulation coordination – enabling current paths (13/14, 23/24, 33/34) amongst each other..... 31
- 16. Ambient data.....31
- 17. Ordering information..... 35

Australia
Phone +61 (3) 9457 0600
1800 33 48 02 – tollfree
E-Mail sales@sick.com.au

Austria
Phone +43 (0) 2236 62288-0
E-Mail office@sick.at

Belgium/Luxembourg
Phone +32 (0) 2 466 55 66
E-Mail info@sick.be

Brazil
Phone +55 11 3215-4900
E-Mail comercial@sick.com.br

Canada
Phone +1 905.771.1444
E-Mail cs.canada@sick.com

Czech Republic
Phone +420 234 719 500
E-Mail sick@sick.cz

Chile
Phone +56 (2) 2274 7430
E-Mail chile@sick.com

China
Phone +86 20 2882 3600
E-Mail info.china@sick.net.cn

Denmark
Phone +45 45 82 64 00
E-Mail sick@sick.dk

Finland
Phone +358-9-25 15 800
E-Mail sick@sick.fi

France
Phone +33 1 64 62 35 00
E-Mail info@sick.fr

Germany
Phone +49 (0) 2 11 53 010
E-Mail info@sick.de

Greece
Phone +30 210 6825100
E-Mail office@sick.com.gr

Hong Kong
Phone +852 2153 6300
E-Mail ghk@sick.com.hk

Hungary
Phone +36 1 371 2680
E-Mail ertekesites@sick.hu

India
Phone +91-22-6119 8900
E-Mail info@sick-india.com

Israel
Phone +972 97110 11
E-Mail info@sick-sensors.com

Italy
Phone +39 02 27 43 41
E-Mail info@sick.it

Japan
Phone +81 3 5309 2112
E-Mail support@sick.jp

Malaysia
Phone +603-8080 7425
E-Mail enquiry.my@sick.com

Mexico
Phone +52 (472) 748 9451
E-Mail mexico@sick.com

Netherlands
Phone +31 (0) 30 229 25 44
E-Mail info@sick.nl

New Zealand
Phone +64 9 415 0459
0800 222 278 – tollfree
E-Mail sales@sick.co.nz

Norway
Phone +47 67 81 50 00
E-Mail sick@sick.no

Poland
Phone +48 22 539 41 00
E-Mail info@sick.pl

Romania
Phone +40 356-17 11 20
E-Mail office@sick.ro

Russia
Phone +7 495 283 09 90
E-Mail info@sick.ru

Singapore
Phone +65 6744 3732
E-Mail sales.gsg@sick.com

Slovakia
Phone +421 482 901 201
E-Mail mail@sick-sk.sk

Slovenia
Phone +386 591 78849
E-Mail office@sick.si

South Africa
Phone +27 10 060 0550
E-Mail info@sickautomation.co.za

South Korea
Phone +82 2 786 6321/4
E-Mail infokorea@sick.com

Spain
Phone +34 93 480 31 00
E-Mail info@sick.es

Sweden
Phone +46 10 110 10 00
E-Mail info@sick.se

Switzerland
Phone +41 41 619 29 39
E-Mail contact@sick.ch

Taiwan
Phone +886-2-2375-6288
E-Mail sales@sick.com.tw

Thailand
Phone +66 2 645 0009
E-Mail marcom.th@sick.com

Turkey
Phone +90 (216) 528 50 00
E-Mail info@sick.com.tr

United Arab Emirates
Phone +971 (0) 4 88 65 878
E-Mail contact@sick.ae

United Kingdom
Phone +44 (0)17278 31121
E-Mail info@sick.co.uk

USA
Phone +1 800.325.7425
E-Mail info@sick.com

Vietnam
Phone +65 6744 3732
E-Mail sales.gsg@sick.com

Detailed addresses and further locations at www.sick.com

