

# MultiPulse - WTB4-3P2100S14

MultiTask photoelectric sensors

en / de / fr / it / pt / es / zh / ja / ru



# Photoelectric proximity sensor

## Operating instructions

### 1 Safety notes

- Read the operating instructions before commissioning.
- Connection, mounting, and setting may only be performed by trained specialists.
- Not a safety component in accordance with the EU Machinery Directive.
- UL: Only for use in applications in accordance with NFPA 79. These devices shall be protected by a 1 A fuse suitable for 30 V DC. Adapters listed by UL with connection cables are available. Enclosure type 1
- When commissioning, protect the device from moisture and contamination.
- These operating instructions contain information required during the life cycle of the sensor.

### 2 Correct use

The MultiPulse WTB4-3 is an opto-electronic photoelectric proximity sensor (referred to as "sensor" in the following) for the optical, non-contact detection of objects. If the product is used for any other purpose or modified in any way, any warranty claim against SICK AG shall become void.

Photoelectric proximity sensor with background suppression.

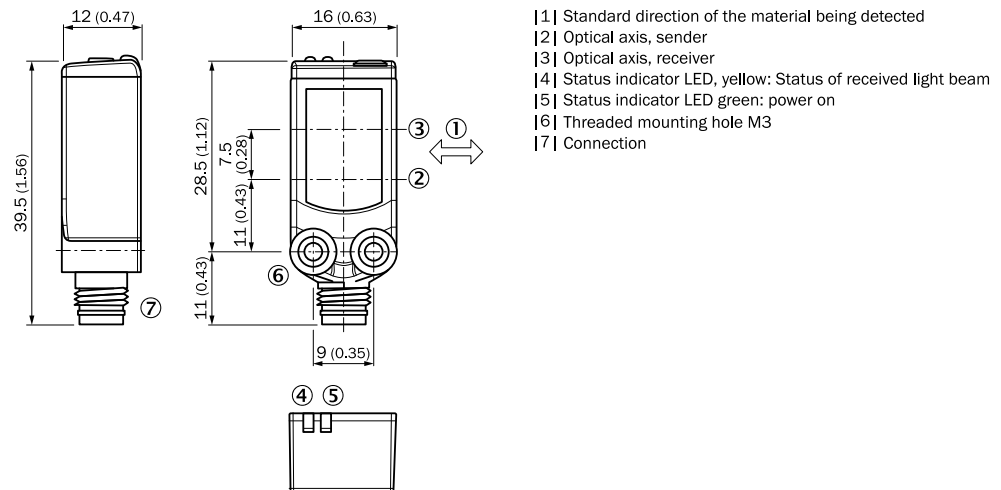

Image: A

### 3 Commissioning

- 1 Mount the sensor using a suitable mounting bracket (see the SICK range of accessories).  
Note the sensor's maximum permissible tightening torque of 0.8 Nm.
- 2 The sensors must be connected in a voltage-free state ( $U_v = 0$  V). The information in the graphics [B] must be observed, depending on the connection type:
  - Male connector connection: pin assignment

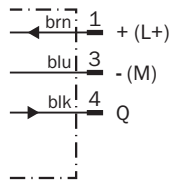

Image: B

Only apply voltage/switch on the power supply ( $U_v > 0\text{ V}$ ) once all electrical connections have been established. The green LED indicator lights up on the sensor. Explanations of the connection diagram (Graphic B):

MultiPulse WTB4-3P (PNP: load -> M)

Output oscillates at 10 Hz if an object is located within the fixed sensing range 30 to 100 mm. Output switches off if an object is located within the range 0 to 30 mm and > 100 mm.

- 3 Align the sensor with the object. Select the position so that the red emitted light beam hits the center of the object. You must ensure that the optical opening (front screen) of the sensor is completely clear [E]. We recommend making the adjustments using an object with a low remission.

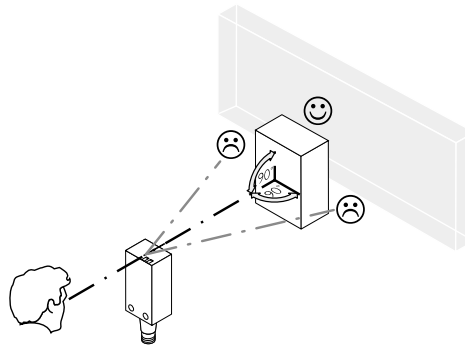

Image: E

- 4 Sensor which it is not possible to set: The sensor is adjusted and ready for operation. The fixed sensing range is 30 ... 100 mm.

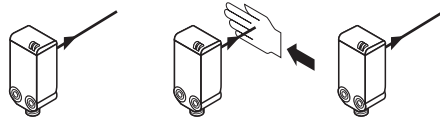

Image: C

## 5 Fault diagnosis

Table indicates which measures are to be taken if the sensor stops working.

## 6 Table Fault diagnosis

LED indicator/fault pattern / LED indicator/fault pattern	Cause / Cause	Measures / Measures
Green LED does not light up / Green LED does not light up	No voltage or voltage below the limit values / No voltage or voltage below the limit values	Check the power supply, check all electrical connecti- ons (cables and plug connecti- ons) / Check the power supply, check all electrical connecti- ons (cables and plug connecti- ons)
Green LED does not light up / Green LED does not light up	Voltage interruptions / Voltage interruptions	Ensure there is a stable power supply without interruptions / Ensure there is a stable power supply without interruptions
Green LED does not light up / Green LED does not light up	Sensor is faulty / Sensor is faulty	If the power supply is OK, replace the sensor / If the power supply is OK, replace the sensor
Yellow LED flashes / Yellow LED flashes	Sensor is still ready for opera- tion, but the operating condi- tions are not ideal / Sensor is still ready for opera- tion, but the operating condi- tions are not ideal	Check the operating condi- tions: Fully align the beam of light (light spot) with the object. / Clean the optical sur- faces. / Readjust the sensi- tivity / Check sensing range and adjust if necessary; see graphic F. / Check the operating condi- tions: Fully align the beam of light (light spot) with the object. / Clean the optical sur- faces. / Readjust the sensi- tivity / Check sensing range and adjust if necessary; see graphic F.
Yellow LED lights up, no object in the path of the beam / Yellow LED lights up, no object in the path of the beam	/ Distance between the sen- sor and the background is too short / / Distance between the sen- sor and the background is too short	Reduce the sensing range, see graphic F / Reduce the sensing range, see graphic F
Object is in the path of the beam, yellow LED does not light up / Object is in the path of the beam, yellow LED does not light up	Distance between the sensor and the object is too long or sensing range is set too short / Distance between the sensor and the object is too long or sensing range is set too short	Increase the sensing range, see graphic F / Increase the sensing range, see graphic F

## 7 Disassembly and disposal

The sensor must be disposed of according to the applicable country-specific regulations. Efforts should be made during the disposal process to recycle the constituent materials (particularly precious metals).

## 8 Maintenance

SICK sensors are maintenance-free.

We recommend doing the following regularly:

- Clean the external lens surfaces
- Check the screw connections and plug-in connections

No modifications may be made to devices.

Subject to change without notice. Specified product properties and technical data are not written guarantees.

## 9 Technical data

	WTB4-3P2100S14
Sensing range	30 ... 100 mm
Sensing range max.	30 ... 100 mm <sup>1)</sup>
Light spot diameter/distance	7 mm / 50 mm
Supply voltage $V_S$	DC 10 ... 30 V <sup>2)</sup>
Output current $I_{max}$	100 mA
Max. switching frequency	2 Hz <sup>3)</sup>
Max. response time	250 ms <sup>4)</sup>
Enclosure rating	IP 67
Protection class	III
Circuit protection	A,C,D <sup>5)</sup>
Ambient operating temperature	-40 ... +60 °C
<sup>1)</sup> Object with 90 % remission (based on standard white DIN 5033) <sup>2)</sup> Limit value: operation in short-circuit protection mains max. 8 A; residual ripple max. 5 V <sub>ss</sub> <sup>3)</sup> With light / dark ratio 1:1 <sup>4)</sup> Signal transit time with resistive load <sup>5)</sup> A = UV-connections reverse polarity protected C = Interference suppression D = outputs overcurrent and short-circuit protected	

# Reflexions-Lichttaster

## Betriebsanleitung

### 10 Sicherheitshinweise

- Vor der Inbetriebnahme die Betriebsanleitung lesen.
- Anschluss, Montage und Einstellung nur durch Fachpersonal.
- Kein Sicherheitsbauteil gemäß EU-Maschinenrichtlinie.
- UL: Nur zur Verwendung in Anwendungen gemäß NFPA 79. Diese Geräte müssen mit einer für 30V DC geeigneten 1A-Sicherung abgesichert werden. Von UL gelistete Adapter mit Anschlusskabeln sind verfügbar. Enclosure type 1
- Gerät bei Inbetriebnahme vor Feuchte und Verunreinigung schützen.
- Diese Betriebsanleitung enthält Informationen, die während des Lebenszyklus des Sensors notwendig sind.

### 11 Bestimmungsgemäße Verwendung

Die MultiPulse WTB4-3 ist ein optoelektronischer Reflexions-Lichttaster (im Folgenden Sensor genannt) und wird zum optischen, berührungslosen Erfassen von Sachen eingesetzt. Bei jeder anderen Verwendung und bei Veränderungen am Produkt verfällt jeglicher Gewährleistungsanspruch gegenüber der SICK AG.

Reflexionslichttaster mit Hintergrundausbldung.



Abb.: A

### 12 Inbetriebnahme

- 1 Den Sensor an einen geeigneten Befestigungswinkel montieren (siehe SICK-Zubehör-Programm).  
Maximal zulässiges Anzugsdrehmoment des Sensors von 0.8 Nm beachten.
- 2 Anschluss der Sensoren muss spannungsfrei ( $U_V = 0\text{ V}$ ) erfolgen. Je nach Anschlussart sind die Informationen in den Grafiken [vgl. B] zu beachten:
  - Steckeranschluss: Pinbelegung

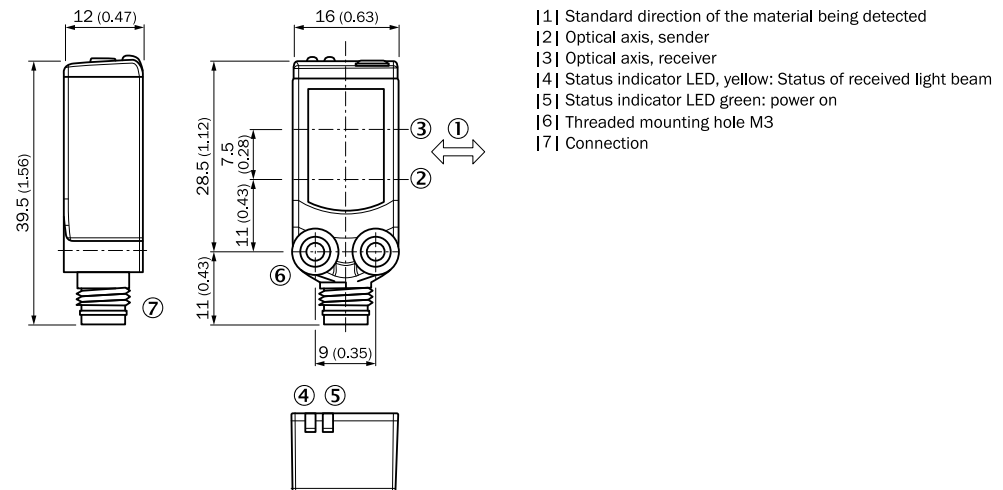

Abb.: B

Erst nach Anschluss aller elektrischen Verbindungen die Spannungsversorgung ( $U_V > 0\text{ V}$ ) anlegen bzw. einschalten. Am Sensor leuchtet die grüne Anzeige-LED.

Erläuterungen zum Anschlussschema (Grafik B):

MultiPulse WTB4-3P (PNP: Last -> M)

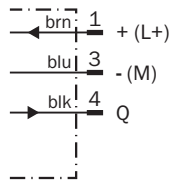
Ausgang schwingt mit 10 Hz, wenn sich ein Objekt im fixen Schaltbereich 30 ... 100 mm befindet. Ausgang schaltet aus, wenn sich ein Objekt im Bereich 0 ... 30 mm und > 100 mm befindet.

- 3 Sensor auf Objekt ausrichten. Positionierung so wählen, dass der rote Sendelichtstrahl in der Mitte des Objekts auftrifft. Es ist darauf zu achten, dass die optische Öffnung (Frontscheibe) des Sensors vollständig frei ist [vgl. E]. Wir empfehlen, die Einstellung mit einem Objekt von niedriger Remission vorzunehmen.



Abb.: E

- 4 Sensor ohne Einstellmöglichkeit: Sensor ist eingestellt und betriebsbereit. Der fixe Schaltabstand beträgt 30 ... 100 mm.

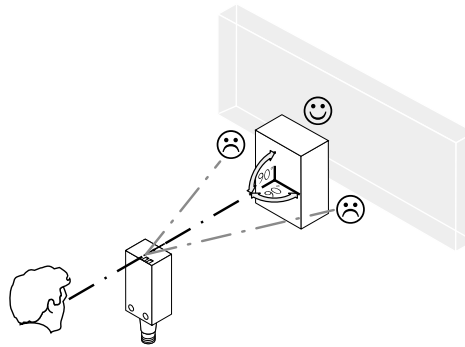

Abb.: C

## 14 Fehlerdiagnose

Tabelle I zeigt, welche Maßnahmen durchzuführen sind, wenn die Funktion des Sensors nicht mehr gegeben ist.

## 15 Tabelle Fehlerdiagnose

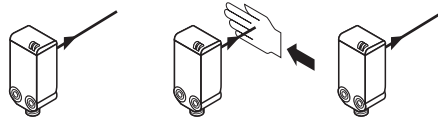
Anzeige-LED / Fehlerbild / LED indicator/fault pattern	Ursache / Cause	Maßnahme / Measures
grüne LED leuchtet nicht / Green LED does not light up	keine Spannung oder Spannung unterhalb der Grenzwerte / No voltage or voltage below the limit values	Spannungsversorgung prüfen, den gesamten elektrischen Anschluss prüfen (Leitungen und Steckerverbindungen) / Check the power supply, check all electrical connections (cables and plug connections)
grüne LED leuchtet nicht / Green LED does not light up	Spannungsunterbrechungen / Voltage interruptions	Sicherstellen einer stabilen Spannungsversorgung ohne Unterbrechungen / Ensure there is a stable power supply without interruptions
grüne LED leuchtet nicht / Green LED does not light up	Sensor ist defekt / Sensor is faulty	Wenn Spannungsversorgung in Ordnung ist, dann Sensor austauschen / If the power supply is OK, replace the sensor
gelbe LED blinkt / Yellow LED flashes	Sensor ist noch betriebsbereit, aber die Betriebsbedingungen sind nicht optimal / Sensor is still ready for operation, but the operating conditions are not ideal	Betriebsbedingungen prüfen: Lichtstrahl (Lichtfleck) vollständig auf das Objekt ausrichten / Reinigung der optischen Flächen / Empfindlichkeit neu einstellen / Schaltabstand überprüfen und ggf. anpassen, siehe Grafik F. / Check the operating conditions: Fully align the beam of light (light spot) with the object. / Clean the optical surfaces. / Readjust the sensitivity / Check sensing range and adjust if necessary; see graphic F.
gelbe LED leuchtet, kein Objekt im Strahlengang / Yellow LED lights up, no object in the path of the beam	Abstand zwischen Sensor und Hintergrund ist zu gering / / Distance between the sensor and the background is too short	Schaltabstand verringern, siehe Grafik F / Reduce the sensing range, see graphic F
Objekt ist im Strahlengang, gelbe LED leuchtet nicht / Object is in the path of the beam, yellow LED does not light up	Abstand zwischen Sensor und Objekt ist zu groß oder Schaltabstand ist zu gering eingestellt / Distance between the sensor and the object is too long or sensing range is set too short	Schaltabstand vergrößern, siehe Grafik F / Increase the sensing range, see graphic F

## 16 Demontage und Entsorgung

Die Entsorgung des Sensors hat gemäß den länderspezifisch anwendbaren Vorschriften zu erfolgen. Für die enthaltenen Wertstoffe (insbesondere Edelmetalle) ist im Rahmen der Entsorgung eine Verwertung anzustreben.



## 17 Wartung

SICK-Sensoren sind wartungsfrei.

Wir empfehlen, in regelmäßigen Abständen

- die optischen Grenzflächen zu reinigen
- Verschraubungen und Steckverbindungen zu überprüfen

Veränderungen an Geräten dürfen nicht vorgenommen werden.

Irrtümer und Änderungen vorbehalten. Angegebene Produkteigenschaften und technische Daten stellen keine Garantieerklärung dar.

## 18 Technische Daten

	<b>WTB4-3P2100S14</b>
Schaltabstand	30 ... 100 mm
Schaltabstand max.	30 ... 100 mm <sup>6)</sup>
Lichtfleckdurchmesser/Entfernung	7 mm / 50 mm
Versorgungsspannung $U_V$	DC 10 ... 30 V <sup>7)</sup>
Ausgangsstrom $I_{max}$	100 mA
Schaltfolge max.	2 Hz <sup>8)</sup>
Ansprechzeit max.	250 ms <sup>9)</sup>
Schutzart	IP 67
Schutzklasse	III
Schutzschaltungen	A,C,D <sup>10)</sup>
Betriebsumgebungstemperatur	-40 ... +60 °C
<sup>1)</sup> Tastgut mit 90 % Remission (bezogen auf Standard-Weiß DIN 5033) <sup>2)</sup> Grenzwerte: Betrieb im kurzschlussgeschützten Netz max. 8 A; Restwelligkeit max. 5 V <sub>ss</sub> <sup>3)</sup> Mit Hell- / Dunkelverhältnis 1:1 <sup>4)</sup> Signallaufzeit bei ohmscher Last <sup>5)</sup> A = UV-Anschlüsse verpolsicher C = Störimpulsunterdrückung D = Ausgänge überstrom- und kurzschlussfest	

# Détecteur à réflexion directe

## Notice d'instruction

### 19 Consignes de sécurité

- Lire la notice d'instruction avant la mise en service.
- Confier le raccordement, le montage et le réglage uniquement à un personnel spécialisé.
- Il ne s'agit pas d'un composant de sécurité au sens de la directive machines CE.
- UL : utilisation uniquement dans des applications selon la NFPA 79. Ces appareils doivent être protégés par un fusible de 1 A adapté à du 30 V C.C. Des adaptateurs listés UL avec câbles de connexion sont disponibles. Enclosure type 1
- Protéger l'appareil contre l'humidité et les impuretés lors de la mise en service.
- Cette notice d'instruction contient des informations nécessaires pendant toute la durée de vie du capteur.

### 20 Utilisation conforme

MultiPulse WTB4-3 est un détecteur à réflexion directe optoélectronique (appelé capteur dans ce document) qui permet la détection optique sans contact d'objets. Toute autre utilisation ou modification du produit annule la garantie de SICK AG.

Détecteur à réflexion directe avec élimination d'arrière-plan.

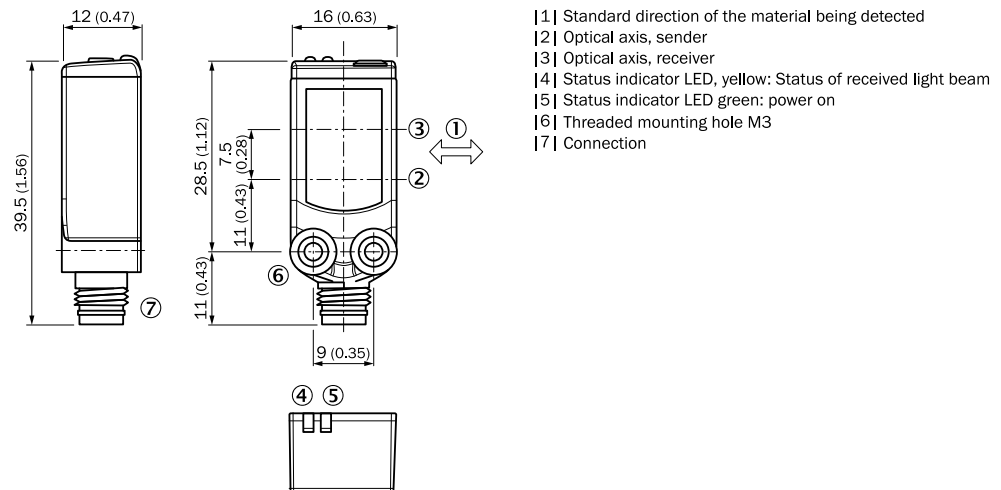

Image: A

### 21 Mise en service

- 1 Monter le capteur sur une équerre de fixation adaptée (voir la gamme d'accessoires SICK).  
Respecter le couple de serrage maximum autorisé du capteur de 0.8 Nm
- 2 Le raccordement des capteurs doit s'effectuer hors tension ( $U_V = 0$  V). Selon le mode de raccordement, respecter les informations contenues dans les schémas [B]:
  - Raccordement du connecteur : affectation des broches

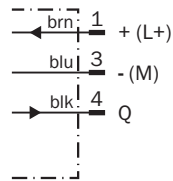

Image: B

Après avoir terminé tous les raccordements électriques, enclencher l'alimentation électrique ( $U_v > 0\text{ V}$ ). La DEL verte s'allume sur le capteur.

Explications relatives au schéma de raccordement (schéma B) :

MultiPulse WTB4-3P (PNP : charge -> M)

La sortie s'active à une fréquence de 10 Hz dès qu'un objet se trouve dans la plage de commutation fixe de 30 à 100 mm. La sortie se désactive dès qu'un objet se trouve dans la plage de commutation fixe de 30 à 100 mm.

- Aligner le capteur sur l'objet. Sélectionner la position de sorte que le faisceau lumineux émis rouge touche l'objet en plein milieu. S'assurer que l'ouverture optique (vitre frontale) du capteur est parfaitement dégagée [voir E]. Nous recommandons de procéder au réglage avec un objet peu réfléchissant.

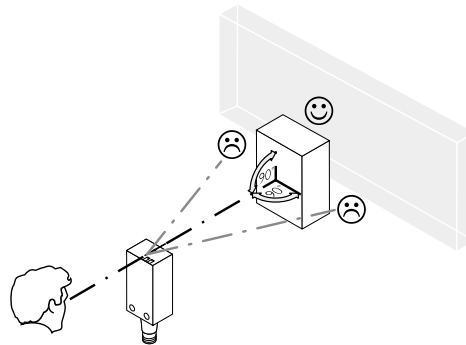

Image: E

- Capteur sans possibilité de réglage : le capteur est réglé et prêt à l'emploi. La portée est comprise entre 30 et 100 mm.

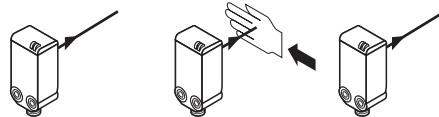

Image: C

## 23 Diagnostic

Le tableau I présente les mesures à appliquer si le capteur ne fonctionne plus.

## 24 Tableau Diagnostic

LED d'état / image du défaut / LED indicator/fault pattern	Cause / Cause	/ Mesures
La LED verte ne s'allume pas / Green LED does not light up	Pas de tension ou tension inférieure aux valeurs limites / No voltage or voltage below the limit values	Contrôler l'alimentation électrique, contrôler tous les branchements électriques (câbles et connexions) / Check the power supply, check all electrical connections (cables and plug connections)
La LED verte ne s'allume pas / Green LED does not light up	Coupures d'alimentation électrique / Voltage interruptions	S'assurer que l'alimentation électrique est stable et ininterrompue / Ensure there is a stable power supply without interruptions
La LED verte ne s'allume pas / Green LED does not light up	Le capteur est défectueux / Sensor is faulty	Si l'alimentation électrique est en bon état, remplacer le capteur / If the power supply is OK, replace the sensor
La LED jaune clignote / Yellow LED flashes	Le capteur est encore opérationnel, mais les conditions d'utilisation ne sont pas idéales / Sensor is still ready for operation, but the operating conditions are not ideal	Vérifier les conditions d'utilisation : Diriger le faisceau lumineux (spot lumineux) entièrement sur l'objet / Nettoyage des surfaces optiques / Régler à nouveau la sensibilité / Contrôler la portée et éventuellement l'adapter, voir le schéma F et . / Check the operating conditions: Fully align the beam of light (light spot) with the object. / Clean the optical surfaces. / Readjust the sensitivity / Check sensing range and adjust if necessary; see graphic F.
La LED jaune s'allume, pas d'objet dans la trajectoire du faisceau / Yellow LED lights up, no object in the path of the beam	La distance entre le capteur et l'arrière-plan est trop faible / Distance between the sensor and the background is too short	Réduire la portée, voir le schéma F / Reduce the sensing range, see graphic F
L'objet est dans la trajectoire du faisceau, la LED jaune ne s'allume pas / Object is in the path of the beam, yellow LED does not light up	La distance entre le capteur et l'objet est trop grande ou la portée est trop faible / Distance between the sensor and the object is too long or sensing range is set too short	Augmenter la portée, voir le schéma F / Increase the sensing range, see graphic F

### 25 Démontage et mise au rebut

La mise au rebut du capteur doit respecter la réglementation nationale en vigueur. Dans le cadre de la mise au rebut, veiller à recycler les matériaux (notamment les métaux précieux).

### 26 Maintenance

Les capteurs SICK ne nécessitent aucune maintenance.

Nous vous recommandons de procéder régulièrement

- au nettoyage des surfaces optiques
- au contrôle des vissages et des connexions enfichables

Ne procéder à aucune modification sur les appareils.

Sujet à modification sans préavis. Les caractéristiques du produit et techniques fournies ne sont pas une déclaration de garantie.

### 27 Caractéristiques techniques

	WTB4-3P2100S14
Distance de commutation	30 ... 100 mm
Portée max.	30 ... 100 mm <sup>11)</sup>
Diamètre spot / distance	7 mm / 50 mm
Tension d'alimentation U <sub>v</sub>	DC 10 ... 30 V <sup>12)</sup>
Courant de sortie I <sub>max</sub>	100 mA
Commutation max.	2 Hz <sup>13)</sup>
Temps de réponse max.	250 ms <sup>14)</sup>
Indice de protection	IP 67
Classe de protection	III
Protections électriques	A,C,D <sup>15)</sup>
Température de service	-40 ... +60 °C
<sup>1)</sup> Objet avec 90 % de réémission (par rapport au blanc standard selon DIN 5033) <sup>2)</sup> Valeurs limites : fonctionnement sur réseau protégé contre les courts-circuits max. 8 A ; ondulation résiduelle max. 5 Vcc <sup>3)</sup> Pour un rapport clair/sombre de 1:1 <sup>4)</sup> Temps de propagation du signal sur charge ohmique <sup>5)</sup> A = raccordements UV protégés contre les inversions de polarité C = Suppression des impulsions parasites D = sorties protégées contre les courts-circuits et les surcharges	

# Interruptor fotoelétrico de reflexão

## Manual de instruções

### 28 Notas de segurança

- Ler as instruções de operação antes da colocação em funcionamento.
- A conexão, a montagem e o ajuste devem ser executados somente por pessoal técnico qualificado.
- Os componentes de segurança não se encontram em conformidade com a Diretiva Europeia de Máquinas.
- UL: Somente na utilização em aplicações de acordo com NFPA 79. Estes dispositivos devem ser protegidos por um fusível de 1 A adequado para 30 VCC. Estão disponíveis adaptadores listados pela UL com cabos de conexão. Enclosure type 1
- Durante o funcionamento, manter o aparelho protegido contra impurezas e umidade.
- Este manual de instruções contém informações necessárias para toda a vida útil do sensor.

### 29 Especificações de uso

O MultiPulse WTB4-3 é um sensor fotoelétrico de proximidade utilizado para a detecção óptica, sem contato, de objetos. Qualquer utilização diferente ou alterações do produto provocam a perda da garantia da SICK AG.

Sensor de luz de reflexão com supressão de fundo.

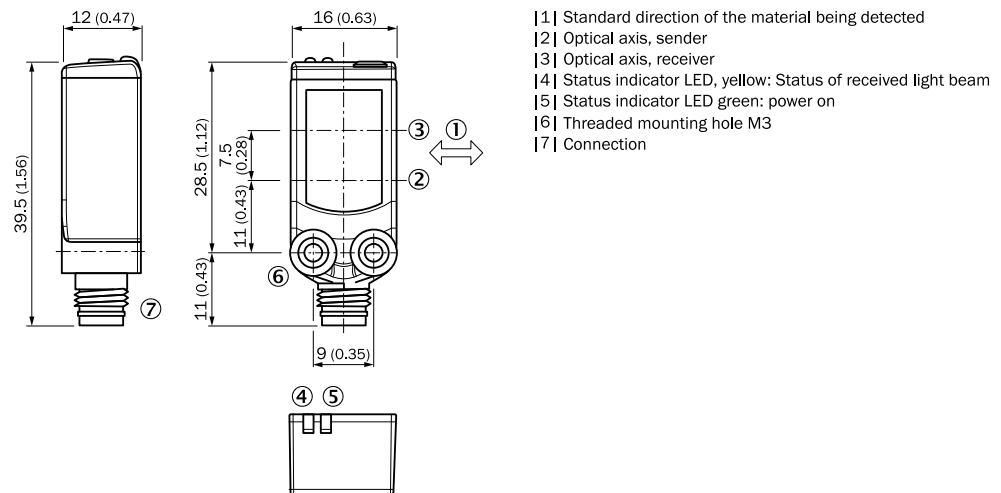

Image: A

### 30 Colocação em operação

- 1 Montar o sensor numa cantoneira de fixação adequada (ver linha de acessórios da SICK).  
Observar o torque de aperto máximo permitido de 0.8 Nm para o sensor.

- 2 A conexão dos sensores deve ser realizada em estado desenergizado ( $U_V = 0\text{ V}$ ). Conforme o tipo de conexão, devem ser observadas as informações contidas nos gráficos [cp. B]:

- Conector: Pin-out

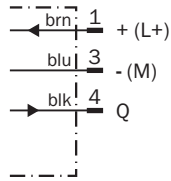

Image: B

Instalar ou ligar a alimentação de tensão ( $U_V > 0\text{ V}$ ) somente após a conexão de todas as conexões elétricas. O indicador LED verde está aceso no sensor.

Explicações relativas ao esquema de conexões (Gráfico B):

MultiPulse WTB4-3P (PNP: carga  $\rightarrow$  M)

A saída oscila com 10 Hz quando um objeto se encontra na faixa de comutação fixa entre 30 mm e 100 mm. Saída desliga quando um objeto se encontra na faixa entre 0 mm e 30 mm e  $> 100\text{ mm}$ .

- 3 Alinhar o sensor ao objeto. Posicionar, de forma que o feixe da luz de emissão vermelha incida sobre o centro do objeto. Certificar-se de que a abertura óptica (vidro frontal) do sensor esteja completamente livre [cp. E]. Recomendamos efetuar o ajuste com um objeto de baixa luminância.

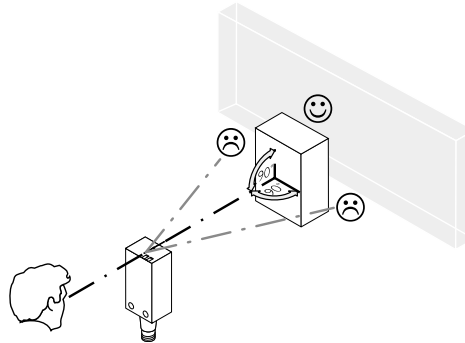

Image: E

- 4 Sensor sem possibilidade de ajuste: Sensor está ajustado e operacional. A distância de comutação fixa é de 30 mm a 100 mm.

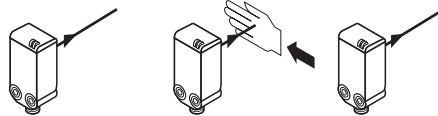

Image: C

## 32 Diagnóstico de erros

A tabela I mostra as medidas a serem executadas, quando o sensor não estiver funcionando.

## 33 Tabela Diagnóstico de erros

Indicador LED / padrão de erro / LED indicator/fault pattern	Causa / Cause	Medida / Measures
LED verde apagado / Green LED does not light up	Sem tensão ou tensão abaixo dos valores-limite / No voltage or voltage below the limit values	Verificar a alimentação de tensão, verificar toda a conexão elétrica (cabos e conectores) / Check the power supply, check all electrical connections (cables and plug connections)
LED verde apagado / Green LED does not light up	Interrupções de tensão / Voltage interruptions	Assegurar uma alimentação de tensão estável sem interrupções / Ensure there is a stable power supply without interruptions
LED verde apagado / Green LED does not light up	Sensor está com defeito / Sensor is faulty	Se a alimentação de tensão estiver em ordem, substituir o sensor / If the power supply is OK, replace the sensor
LED amarelo intermitente / Yellow LED flashes	Sensor ainda está operacional, mas as condições de operação não são ideais / Sensor is still ready for operation, but the operating conditions are not ideal	Verificar as condições de operação: Alinhar o feixe de luz (ponto de luz) completamente ao objeto / Limpeza das superfícies ópticas / reajustar a sensibilidade / Verificar e, se necessário, adaptar a distância de comutação, ver gráfico F. / Check the operating conditions: Fully align the beam of light (light spot) with the object. / Clean the optical surfaces. / Readjust the sensitivity / Check sensing range and adjust if necessary; see graphic F.
LED amarelo aceso, nenhum objeto no caminho óptico / Yellow LED lights up, no object in the path of the beam	Distância entre sensor e fundo é pequena demais / Distance between the sensor and the background is too short	Reduzir a distância de comutação, ver gráfico F / Reduce the sensing range, see graphic F
Objeto está no caminho óptico, LED amarelo apagado / Object is in the path of the beam, yellow LED does not light up	Distância entre sensor e objeto é grande demais ou distância de comutação foi ajustada para um valor baixo demais / Distance between the sensor and the object is too long or sensing range is set too short	Aumentar a distância de comutação, ver gráfico F / Increase the sensing range, see graphic F



## 34 Desmontagem e descarte

O descarte do sensor deve ser efetuado de acordo com as normas aplicáveis específicas de cada país. No âmbito do descarte, deve-se procurar o aproveitamento dos materiais recicláveis contidos (principalmente dos metais nobres).

## 35 Manutenção

Os sensores SICK não requerem manutenção.

Recomendamos que se efetue em intervalos regulares

- uma limpeza das superfícies ópticas
- uma verificação das conexões roscadas e dos conectores

Não são permitidas modificações no aparelho.

Sujeito a alterações sem aviso prévio. As propriedades do produto e os dados técnicos especificados não constituem nenhum certificado de garantia.

## 36 Dados técnicos

	WTB4-3P2100S14
Distância de comutação	30 ... 100 mm
Distância de comutação máx.	30 ... 100 mm <sup>16)</sup>
Diâmetro do ponto de luz/distância	7 mm / 50 mm
Tensão de alimentação $U_V$	DC 10 ... 30 V <sup>17)</sup>
Corrente de saída $I_{max}$	100 mA
Sequência máx. de comutação	2 Hz <sup>18)</sup>
Tempo máx. de resposta	250 ms <sup>19)</sup>
Tipo de proteção	IP 67
Classe de proteção	III
Circuitos de proteção	A,C,D <sup>20)</sup>
Temperatura ambiente de funcionamento	-40 ... +60 °C
<sup>1)</sup> Objeto a ser detectado com 90% de luminância (com base no padrão branco DIN 5033) <sup>2)</sup> Valores limite: funcionamento com rede à prova de curto-circuito máx. 8 A; ondulação residual máx. 5 Vss <sup>3)</sup> Com proporção sombra/luz 1:1 <sup>4)</sup> Tempo de funcionamento do sinal com carga ôhmica <sup>5)</sup> A = conexões protegidas contra inversão de pólos UV C = Supressão de impulsos parasitas D = Saídas protegidas contra sobrecorrente e curto-circuito	

# Sensore di luce a riflessione

## Istruzioni per l'uso

### 37 Avvertenze sulla sicurezza

- Prima della messa in funzionamento leggere le istruzioni per l'uso.
- Allacciamento, montaggio e regolazione solo a cura di personale tecnico specializzato.
- Nessun componente di sicurezza ai sensi della direttiva macchine UE.
- UL: Solo per l'utilizzo in applicazioni ai sensi di NFPA 79. Questi dispositivi devono essere protetti con fusibile 1 A idoneo per 30 V dc. Sono disponibili adattatori elencati da UL con cavi di collegamento. Enclosure type 1
- Alla messa in funzionamento proteggere l'apparecchio dall'umidità e dalla sporcizia.
- Queste istruzioni per l'uso contengono le informazioni che sono necessarie durante il ciclo di vita del sensore fotoelettrico. deTec4 core

### 38 Uso conforme alle prescrizioni

La MultiPulse WTB4-3 è una fotocellula a riflessione optoelettronica (di seguito nominato sensore) utilizzata per il rilevamento ottico senza contatto di oggetti. Se viene utilizzata diversamente e in caso di modifiche sul prodotto, decade qualsiasi diritto alla garanzia nei confronti di SICK.

Relè fotoelettrico a riflessione con soppressione dello sfondo.

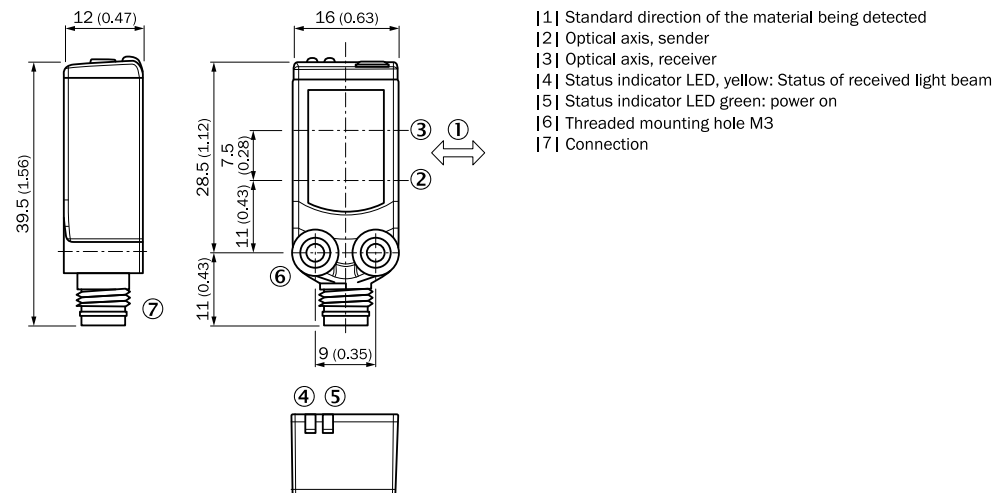

Image: A

### 39 Messa in funzione

- 1 Montare il sensore su un punto di fissaggio adatto (vedi il programma per accessori SICK).  
Rispettare il momento torcente massimo consentito del sensore di 0.8 Nm.
- 2 Il collegamento dei sensori deve avvenire in assenza di tensione ( $U_V = 0$  V). In base al tipo di collegamento si devono rispettare le informazioni nei grafici [cfr. B]:

- Collegamento a spina: assegnazione pin

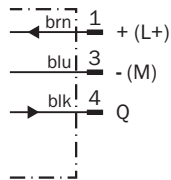

Image: B

Solamente in seguito alla conclusione di tutti i collegamenti elettrici, ripristinare o accendere l'alimentazione elettrica ( $U_V > 0\text{ V}$ ). Sul sensore si accende l'indicatore LED verde.

Spiegazioni dello schema di collegamento (grafico B):

MultiPulse WTB4-3P (PNP: carico -> M)

L'uscita oscilla a una frequenza di 10 Hz quando un oggetto si trova in un campo di commutazione compreso tra 30 e 100 mm. L'uscita si disinscrive quando un oggetto si trova in un campo di scansione compreso tra 0 e 30 mm oppure oltre 100 mm.

- 3 Orientare il sensore sul rispettivo oggetto. Scegliere la posizione in modo tale che il raggio di luce rosso emesso colpisca il centro dell'oggetto. Fare attenzione affinché l'apertura ottica del sensore (finestrella frontale) sia completamente libera [cfr. E]. Si consiglia di effettuare l'impostazione con un oggetto a bassa riflessione.

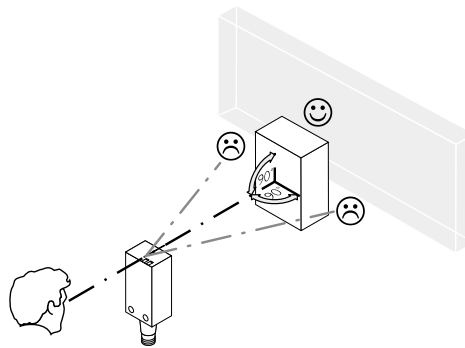

Image: E

- 4 Sensore senza possibilità di impostazione: il sensore è impostato e pronto per il funzionamento. La distanza di commutazione fissa è 30 ... 100 mm.

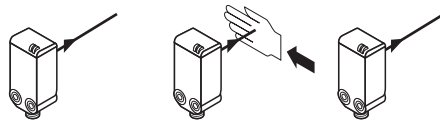

Image: C

## 41 Diagnostica delle anomalie

La tabella I mostra quali provvedimenti si devono adottare quando il sensore non funziona più.

## 42 Tabella diagnostica delle anomalie

Indicatore LED / figura di errore / LED indicator/fault pattern	Causa / Cause	Provvedimento / Measures
Il LED verde non si accende / Green LED does not light up	nessuna tensione o tensione al di sotto del valore soglia / No voltage or voltage below the limit values	Verificare la tensione di alimentazione e/o il collegamento elettrico / Check the power supply, check all electrical connections (cables and plug connections)
Il LED verde non si accende / Green LED does not light up	Interruzioni di tensione / Voltage interruptions	Assicurarsi che ci sia un'alimentazione di tensione stabile / Ensure there is a stable power supply without interruptions
Il LED verde non si accende / Green LED does not light up	Il sensore è guasto / Sensor is faulty	Se l'alimentazione di tensione è regolare, allora chiedere una sostituzione del sensore / If the power supply is OK, replace the sensor
Il LED giallo lampeggia / Yellow LED flashes	Il sensore è ancora pronto per il funzionamento, ma le condizioni di esercizio non sono ottimali / Sensor is still ready for operation, but the operating conditions are not ideal	Controllare le condizioni di esercizio: Dirigere il raggio di luce (il punto luminoso) completamente sull'oggetto / Pulizia delle superfici ottiche / Sensibilità / controllare la distanza di commutazione e, se necessario, adattarla, vedi grafico F. / Check the operating conditions: Fully align the beam of light (light spot) with the object. / Clean the optical surfaces. / Readjust the sensitivity / Check sensing range and adjust if necessary; see graphic F.
il LED giallo si accende, nessun oggetto nella traiettoria del raggio / Yellow LED lights up, no object in the path of the beam	La distanza tra sensore e sfondo è inferiore alle capacità di funzionamento / / Distance between the sensor and the background is too short	Diminuire la distanza di commutazione, vedi grafico F / Reduce the sensing range, see graphic F
L'oggetto è nella traiettoria del raggio, il LED giallo non si accende / Object is in the path of the beam, yellow LED does not light up	La distanza tra sensore e oggetto è troppo grande o la distanza di commutazione ha un'impostazione troppo bassa / Distance between the sensor and the object is too long or sensing range is set too short	Aumentare la distanza di commutazione, vedi grafico F / Increase the sensing range, see graphic F

### 43 Smontaggio e smaltimento

Lo smaltimento del sensore deve avvenire conformemente alle direttive previste specificatamente dal paese. Per i materiali riciclabili in esso contenuti (in particolare metalli nobili) si auspica un riciclaggio nell'ambito dello smaltimento.

### 44 Manutenzione

I sensori SICK sono esenti da manutenzione.

A intervalli regolari si consiglia di

- pulire le superfici limite ottiche
- Verificare i collegamenti a vite e gli innesti a spina

Non è consentito effettuare modifiche agli apparecchi.

Contenuti soggetti a modifiche senza preavviso. Le proprietà del prodotto e le schede tecniche indicate non costituiscono una dichiarazione di garanzia.

### 45 Dati tecnici

	WTB4-3P2100S14
Distanza di commutazione	30 ... 100 mm
Distanza max. di commutazione	30 ... 100 mm <sup>21)</sup>
Diametro punto luminoso/distanza	7 mm / 50 mm
Tensione di alimentazione $U_V$	DC 10 ... 30 V <sup>22)</sup>
Corrente di uscita $I_{max}$	100 mA
Sequenza di commutazione max.	2 Hz <sup>23)</sup>
Tempo di reazione max.	250 ms <sup>24)</sup>
Tipo di protezione	IP 67
Classe di protezione	III
Commutazioni di protezione	A,C,D <sup>25)</sup>
Temperatura ambientale di funzionamento	-40 ... +60 °C
<sup>1)</sup> Oggetto con il 90% di remissione (riferito al bianco standard DIN 5033) <sup>2)</sup> Valori limite: funzionamento in rete protetta da cortocircuito max. 8 A; ondulazione residua max. 5 Vss <sup>3)</sup> Con rapporto chiaro / scuro 1:1 <sup>4)</sup> Durata segnale con carico ohmico <sup>5)</sup> A = UV-Allacciamenti protetti dall'inversione di polarità C = Soppressione impulsi di disturbo D = uscite protette da sovracorrente e da cortocircuito.	

# Sensor fotoeléctrico de reflexión

## Instrucciones de uso

### 46 Instrucciones de seguridad

- Lea las instrucciones de uso antes de efectuar la puesta en servicio.
- La conexión, el montaje y el ajuste deben ser efectuados exclusivamente por técnicos especialistas.
- No se trata de un componente de seguridad según la Directiva de máquinas de la UE.
- UL: solo para utilizar en aplicaciones según NFPA 79. Estos dispositivos estarán protegidos por un fusible de 1 A adecuado para 30 VCC. Se encuentran disponibles adaptadores listados por UL con cable de conexión. Enclosure type 1
- Proteja el equipo contra la humedad y la suciedad durante la puesta en servicio.
- Las presentes instrucciones de uso contienen información que puede serle necesaria durante todo el ciclo de vida del sensor.

### 47 Uso conforme a lo previsto

La MultiPulse WTB4-3 es una fotocélula optoelectrónica de reflexión directa (en lo sucesivo llamada sensor) empleada para la detección óptica y sin contacto de objetos. Cualquier uso diferente al previsto o modificación en el producto invalidará la garantía por parte de SICK AG.

Fotocélula de reflexión directa con supresión de fondo.

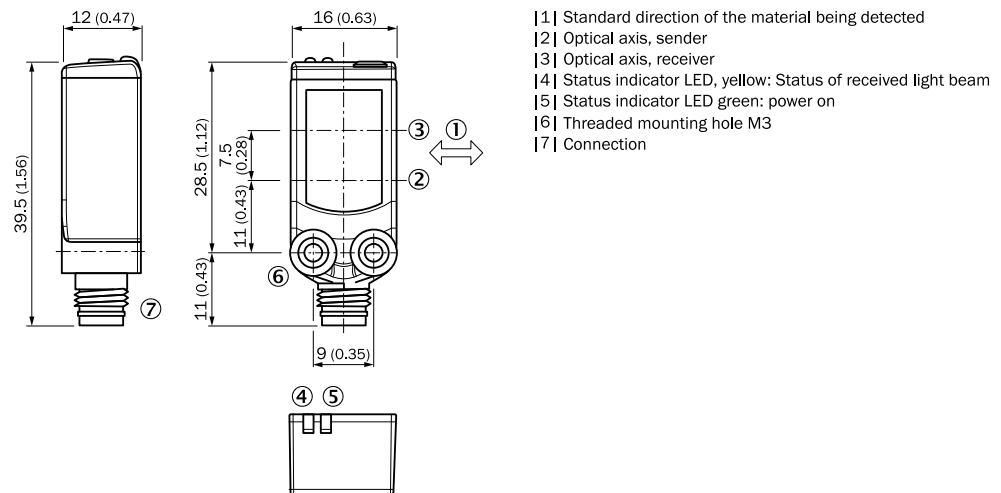

Image: A

### 48 Puesta en servicio

- 1 Montar el sensor en una escuadra de fijación adecuada (véase el programa de accesorios SICK).  
Respetar el par de apriete máximo admisible del sensor de 0.8 Nm.
- 2 Los sensores deben conectarse sin tensión ( $U_V = 0$  V). Debe tenerse en cuenta la información de las figuras [B] en función de cada tipo de conexión:

- Conexión de enchufes: asignación de pines

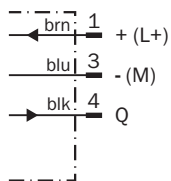

Image: B

No aplicar o conectar la fuente de alimentación ( $U_V > 0\text{ V}$ ) hasta que no se hayan finalizado todas las conexiones eléctricas. En el sensor se ilumina el LED indicador verde.

Explicaciones relativas al esquema de conexión (figura B):

MultiPulse WTB4-3P (PNP: carga  $\rightarrow$  M)

Cuando hay un objeto en el área de conmutación fija de 30 ... 100 mm, la salida fluctúa con 10 Hz. Cuando hay un objeto en el área de 0 ... 30 mm y  $> 100$  mm, la salida se desconecta.

- 3 Oriente el sensor hacia el objeto. Seleccione una posición que permita que el haz de luz roja del transmisor incida en el centro del objeto. Hay que procurar que la apertura óptica (pantalla frontal) del sensor esté completamente libre [véase figura E]. Recomendamos realizar los ajustes con un objeto de remisión baja.

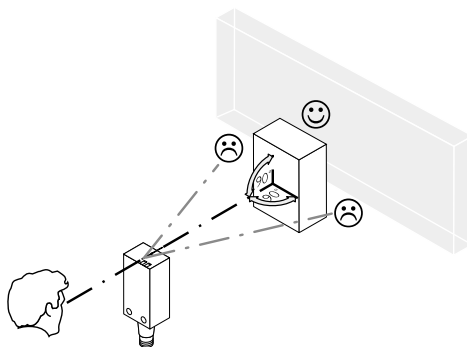

Image: E

- 4 Sensor sin posibilidad de ajuste: el sensor está ajustado y listo para su uso. La distancia fija de conmutación es de 30 ... 100 mm.

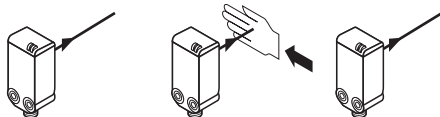

Image: C

## 50 Diagnóstico de fallos

La tabla I muestra las medidas que hay que tomar cuando ya no está indicado el funcionamiento del sensor.

51 Tabla Diagnóstico de fallos

LED indicador / imagen de error / LED indicator/fault pattern	Causa / Cause	Acción / Measures
El LED verde no se ilumina / Green LED does not light up	Sin tensión o tensión por debajo de los valores límite / No voltage or voltage below the limit values	Comprobar la fuente de alimentación, comprobar toda la conexión eléctrica (cables y conectores) / Check the power supply, check all electrical connections (cables and plug connections)
El LED verde no se ilumina / Green LED does not light up	Interrupciones de tensión / Voltage interruptions	Asegurar una fuente de alimentación estable sin interrupciones de tensión / Ensure there is a stable power supply without interruptions
El LED verde no se ilumina / Green LED does not light up	El sensor está defectuoso / Sensor is faulty	Si la fuente de alimentación no tiene problemas, cambiar el sensor / If the power supply is OK, replace the sensor
El LED amarillo parpadea / Yellow LED flashes	El sensor aún está operativo, pero las condiciones de servicio no son óptimas / Sensor is still ready for operation, but the operating conditions are not ideal	Comprobar las condiciones de servicio: Alinear el haz de luz (punto de luz) completamente con el objeto / Limpieza de las superficies ópticas / Reajustar la sensibilidad / Comprobar la distancia de conmutación y, si es necesario, adaptarla, véase Figura F. / Check the operating conditions: Fully align the beam of light (light spot) with the object. / Clean the optical surfaces. / Readjust the sensitivity / Check sensing range and adjust if necessary; see graphic F.
El LED amarillo se ilumina, no hay ningún objeto en la trayectoria del haz / Yellow LED lights up, no object in the path of the beam	La distancia entre el sensor y el fondo es insuficiente / / Distance between the sensor and the background is too short	Reducir la distancia de conmutación, véase Figura F / Reduce the sensing range, see graphic F
El objeto se encuentra en la trayectoria del haz, el LED amarillo no se ilumina / Object is in the path of the beam, yellow LED does not light up	La distancia entre el sensor y el objeto es excesiva o la distancia de conmutación ajustada es insuficiente / Distance between the sensor and the object is too long or sensing range is set too short	Aumentar la distancia de conmutación, véase Figura F / Increase the sensing range, see graphic F



## 52 Desmontaje y eliminación

El sensor tiene que eliminarse siguiendo la normativa aplicable específica de cada país. Los materiales valiosos que contenga (especialmente metales nobles) deben ser eliminados considerando la opción del reciclaje.

## 53 Mantenimiento

Los sensores SICK no precisan mantenimiento.

A intervalos regulares, recomendamos:

- Limpiar las superficies ópticas externas
- Comprobar las uniones roscadas y las conexiones.

No se permite realizar modificaciones en los aparatos.

Sujeto a cambio sin previo aviso. Las propiedades y los datos técnicos del producto no suponen ninguna declaración de garantía.

## 54 Datos técnicos

	WTB4-3P2100S14
Distancia de conmutación	30 ... 100 mm
Distancia de conmutación máx.	30 ... 100 mm <sup>26)</sup>
Diámetro del punto luminoso/distancia	7 mm / 50 mm
Tensión de alimentación U <sub>v</sub>	DC 10 ... 30 V <sup>27)</sup>
Intensidad de salida I <sub>max.</sub>	100 mA
Secuencia de conmutación máx.	2 Hz <sup>28)</sup>
Tiempo de respuesta máx.	250 ms <sup>29)</sup>
Tipo de protección	IP 67
Clase de protección	III
Circuitos de protección	A,C,D <sup>30)</sup>
Temperatura ambiente de servicio	-40 ... +60 °C
<sup>1)</sup> Material con un 90% de reflexión (sobre el blanco estándar según DIN 5033) <sup>2)</sup> Valores límite: funcionamiento en red protegida contra cortocircuitos máx. 8 A; ondulación residual máx. 5 V <sub>ss</sub> <sup>3)</sup> Con una relación claro/oscuras de 1:1 <sup>4)</sup> Duración de la señal con carga óhmica <sup>5)</sup> A = UV protegidas contra polarización inversa C = Supresión de impulsos parásitos D=Salidas a prueba de sobrecorriente y cortocircuitos.	

# 反射式光电传感器 操作说明

## 55 安全须知

- 调试前请阅读操作说明。
- 仅允许由专业人员进行接线、安装和设置。
- 本设备非欧盟机械指令中定义的安全部件。
- UL: 仅限用于符合 NFPA 79 的应用。该设备类型应由一个适用于 30 V 直流电的 1 A 保险丝进行保护。可用 UL 所列出的含连接线缆的连接器. Enclosure type 1
- 调试前防止设备受潮或污染。
- 本操作说明中包含了传感器生命周期中必需的各项信息。

## 56 设计用途

MultiPulse WTB4-3 是一种漫反射式光电传感器（下文简称为“传感器”），用于物体的非接触式光学检测。如滥用本产品或擅自对其改装，则 SICK 公司的所有质保承诺均将失效。

带背景抑制功能的漫反射式光电传感器

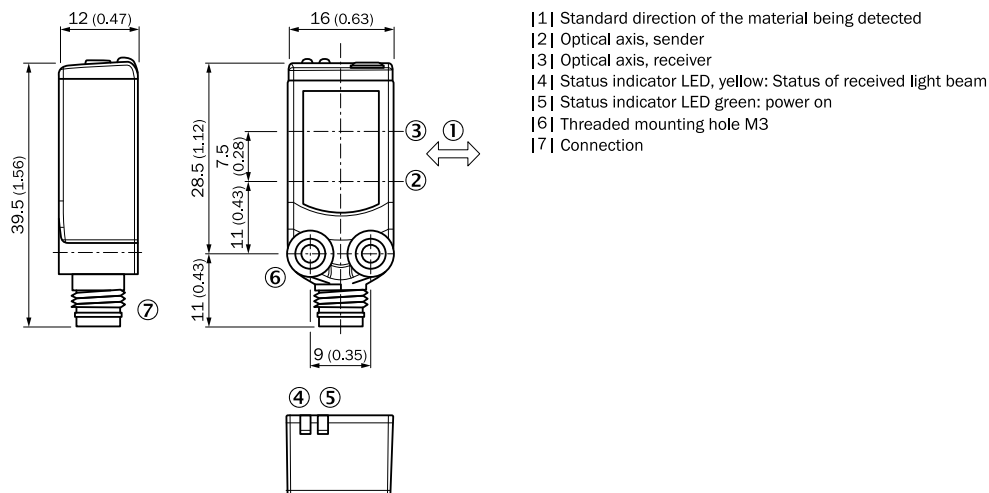

Image: A

## 57 调试

- 1 将传感器安装在合适的安装托架上（参见 SICK 附件说明书）。  
注意传感器的最大允许拧紧扭矩为 0.8 Nm。
- 2 必须在无电压状态 ( $U_V = 0 V$ ) 连接传感器。依据不同连接类型，注意图 [参照 B] 中的信息：
  - 插头连接：引线分配

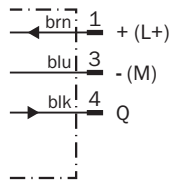

Image: B

完成所有电子连接后，才敷设或接通电源 ( $U_V > 0\text{ V}$ )。传感器上的绿色 LED 指示灯亮起。

接线图 (图 B) 说明:

MultiPulse WTB4-3P (PNP: 负载 -> M)

当物体位于 30 至 100 mm 固定扫描范围内时，输出振荡为 10 Hz。当物体位于 0 至 30 mm 之间及 > 100 mm 范围内时，输出断开。

- 3 将传感器对准物体。选择定位，确保红色发射光束射中物体的中间。此时，应注意传感器的光学开口 (前部玻璃) 处应无任何遮挡 [参照 E]。我们建议使用反射比较低的物体进行设置。

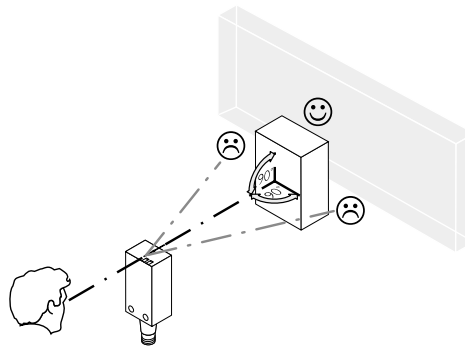

Image: E

- 4 无需设置传感器: 传感器已设置并准备就绪。固定扫描范围为 30 至 100mm。

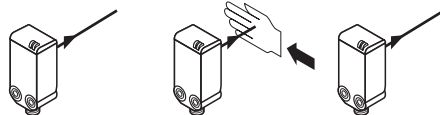

Image: C

## 59 故障诊断

表 I 中罗列了传感器无法执行某项功能时应采取的各项措施。

## 60 表故障诊断

LED 指示灯 / 故障界面 / LED indicator/fault pattern	原因 / Cause	措施 / Measures
绿色 LED 未亮起 / Green LED does not light up	无电压或电压低于极限值 / No voltage or voltage below the limit values	检查电源，检查整体电气连接 (导线和插头连接) /

LED 指示灯 / 故障界面 / LED indicator/fault pattern	原因 / Cause	措施 / Measures
		Check the power supply, check all electrical connections (cables and plug connections)
绿色 LED 未亮起 / Green LED does not light up	电压中断 / Voltage interruptions	确保电源稳定无中断 / Ensure there is a stable power supply without interruptions
绿色 LED 未亮起 / Green LED does not light up	传感器损坏 / Sensor is faulty	如果电源正常，则更换传感器 / If the power supply is OK, replace the sensor
，黄色 LED 闪烁 / Yellow LED flashes	尽管传感器准备就绪，但运行条件不佳 / Sensor is still ready for operation, but the operating conditions are not ideal	检查运行条件：光束（光斑）完全对准物体 / 清洁光学表面 / 重新设置灵敏度 / 检查开关距离，必要时调整；参见图 F。 / Check the operating conditions: Fully align the beam of light (light spot) with the object. / Clean the optical surfaces. / Readjust the sensitivity / Check sensing range and adjust if necessary; see graphic F.
黄色 LED 亮起，光路中无物体 / Yellow LED lights up, no object in the path of the beam	传感器和背景之间的间距过小 / / Distance between the sensor and the background is too short	降低开关距离，参见图 F / Reduce the sensing range, see graphic F
光路中有物体，黄色 LED 未亮起 / Object is in the path of the beam, yellow LED does not light up	传感器和物体之间的间距过大或开关距离设置的过小 / Distance between the sensor and the object is too long or sensing range is set too short	增大开关距离，参见图 F / Increase the sensing range, see graphic F

## 61 拆卸和废弃处理

必须根据当地特定的法律法规废弃处理传感器。如果其中含有可回收材料（尤其是贵金属），则必须在废弃处理时回收利用。

## 62 保养

SICK 传感器无需保养。

我们建议，定期：

- 清洁镜头检测面
- 检查螺栓连接和插头连接

不得对设备进行任何改装。

如有更改，不另行通知。所给出的产品特性和技术参数并非质保声明。

## 63 技术数据

	WTB4-3P2100S14
开关距离	30 ... 100 mm
最大开关距离	30 ... 100 mm <sup>31)</sup>
光斑直径/距离	7 mm / 50 mm
供电电压 $U_V$	DC 10 ... 30 V <sup>32)</sup>
输出电流 $I_{max}$	100 mA
最大开关操作顺序	2 Hz <sup>33)</sup>
最长响应时间	250 ms <sup>34)</sup>
防护类型	IP 67
防护等级	III
保护电路	A,C,D <sup>35)</sup>
工作环境温度	-40 ... +60 °C
1) 具有 90 % 反射比的扫描对象 (指 DIN 5033 规定的标准白) 2) 极限值: 在防短路电网中运行, 最大 8 A; 最大余波 5 Vss 3) 明暗比为 1:1 4) 信号传输时间 (电阻负载时) 5) A = UV 接口 (已采取反极性保护措施) C = 抑制干扰脉冲 D = 抗过载电流和抗短路输出端	

# 光電近接センサ 取扱説明書

## 64 安全上の注意事項

- ご使用前に必ず取扱説明書をお読みください。
- 本製品の接続・取り付け・設定は、訓練を受けた技術者が行って下さい。
- 本製品は EU 機械指令の要件を満たす安全コンポーネントではありません。
- UL : NFPA79 に準拠した用途においてのみご使用ください。この装置は 30V DC 用の 1 A ヒューズによって保護されるものとし、UL 規格によってリストアップされた接続ケーブル付きのアダプターを使用できます。Enclosure type 1
- 使用開始前に、湿気や汚れから機器を保護して下さい。
- 本取扱説明書には、センサのライフサイクル中に必要となる情報が記載されています。

## 65 正しいご使用方法

MultiPulse WTB4-3 とはリフレクタ形光電スイッチ (以下センサと呼ぶ) で、物体を光学技術により非接触で検知するための装置です。製品を用途以外の目的で使用したり改造したりした場合は、SICK AG に対する一切の保証請求権が無効になります。

背景抑制付きリフレクタ形光電スイッチ

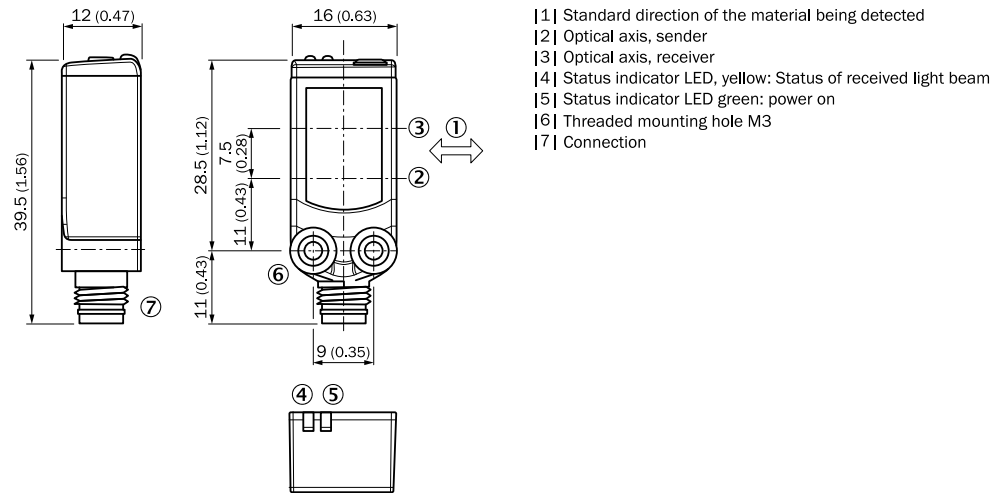

Image: A

## 66 コミッショニング

- 1 適切なブラケットを使用してセンサを取り付けます (SICK 付属品カタログを参照)。  
センサの締め付けトルクの最大許容値 0.8 Nm に注意してください。
- 2 センサの接続は無電圧 ( $U_V = 0V$ ) で行わなければなりません。接続タイプに応じてグラフ [B を参照] の情報に留意してください:
  - コネクタ接続: ピン配置

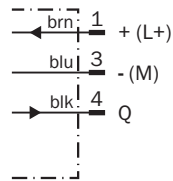

Image: B

すべての電気機器を接続してから供給電圧 ( $U_V > 0V$ ) を印加、あるいは電源を入れてください。センサの緑色の LED 表示灯が点灯します。

接続図の説明 (グラフ B) :

MultiPulse WTB4-3P (PNP: 負荷 → M)

固定検出範囲 30~100 mm に対象物がある場合、出力が 10 Hz で振動します。対象物が 0~30 mm または 100 mm を超える範囲にある場合は、出力が停止します。

- 3 センサを対象物に合わせます。赤色の投光軸が対象物の中央に照射されるように位置を選択します。センサの光開口 (フロントガラス) が全く遮らざることがないように、注意してください [E を参照]。反射率の低い対象物を使用して調整することをお勧めします。

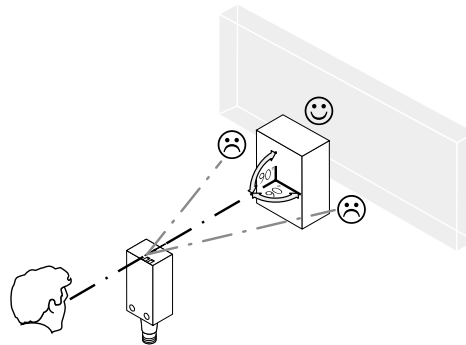

Image: E

- 4 設定不要なセンサ: センサは設定され、動作準備が整っています。固定検出距離は 30~100 mm になります。

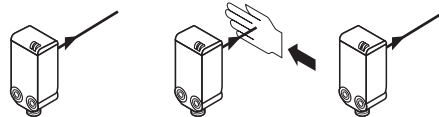

Image: C

## 68 故障診断

表 1 は、センサが機能しなくなった場合に、どのような対策を講じるべきかを示しています。

## 69 表エラー診断

LED 表示灯/故障パターン / LED indicator/fault pattern	原因 / Cause	対策 / Acción
緑色の LED が点灯しない / Green LED does not light up	無電圧、または電圧が限界 値以下 / No voltage or voltage below the limit values	電源を確認し、すべての電 気接続（ケーブルおよびプ ラグ接続）を確認します / Check the power supply, check all electrical connec- tions (cables and plug con- nections)
緑色の LED が点灯しない / Green LED does not light up	電圧がきていない又は不安 定 / Voltage interruptions	安定した電源電圧が供給さ れていることを確認します / Ensure there is a stable power supply without inter- ruptions
緑色の LED が点灯しない / Green LED does not light up	センサの異常 / Sensor is faulty	電源に問題がなければ、セ ンサを交換します / If the power supply is OK, replace the sensor
黄色い LED が点滅 / Yellow LED flashes	センサの動作準備はまだ整 っているが、動作条件が最 適ではない / Sensor is still ready for ope- ration, but the operating conditions are not ideal	動作条件を確認します： 投 光光軸（投光スポット）を 対象物に完全に合わせます / 光学面の洗浄 / 感度を再調 整する / 検出距離を点検し 必要に応じて調整する、グ ラフ F 参照。 / Check the operating condi- tions: Fully align the beam of light (light spot) with the object. / Clean the optical surfaces. / Readjust the sensitivity / Check sensing range and adjust if neces- sary; see graphic F.
黄色い LED が点灯、光軸に 対象物がない / Yellow LED lights up, no object in the path of the beam	/ センサと背景の間隔が短す ぎる / / Distance between the sensor and the background is too short	検出範囲を縮小します。グ ラフ F を参照。 / Reduce the sensing range, see graphic F
対象物は光軸にある、黄色い LED は点灯しない / Object is in the path of the beam, yellow LED does not light up	センサと対象物の間隔が長 すぎる、または検出範囲の 設定が短すぎる / Distance between the sen- sor and the object is too long or sensing range is set too short	検出範囲を拡大します。グ ラフ F を参照。 / Increase the sensing range, see graphic F

## 70 解体および廃棄

センサは必ず該当国の規制にしたがって処分してください。廃棄処理の際には、できるだけ構成材料をリサイクルするよう努めてください（特に貴金属類）。

## 71 メンテナンス

SICK センサはメンテナンスフリーです。



定期的に以下を行うことをお勧めしています：

- レンズ境界面の清掃
- ネジ締結と差込み締結の点検

機器を改造することは禁止されています。

記載内容につきましては予告なしに変更する場合がございますのであらかじめご了承ください。指定された製品特性および技術データは保証書ではありません。

## 72 技術仕様

	WTB4-3P2100S14
検出範囲	30 ... 100 mm
最大検出範囲	30 ... 100 mm <sup>36)</sup>
光点のスポット径/距離	7 mm / 50 mm
供給電圧 $U_V$	DC 10 ... 30 V <sup>37)</sup>
出力電流 $I_{max}$	100 mA
最大スイッチング周波数	2 Hz <sup>38)</sup>
最大応答時間	250 ms <sup>39)</sup>
保護等級	IP 67
保護クラス	III
回路保護	A,C,D <sup>40)</sup>
周辺温度 (作動中)	-40 ... +60 °C
1) 反射率 90 % の対象物 (DIN 5033 に準拠した白色) 2) 限界値：短絡保護の操作は最大 8 A；残留リップルは最大 5 V <sub>ss</sub> 3) ライト/ダークの比率 1:1 4) 負荷のある信号経過時間 5) A = UV 電源電圧逆接保護 C = 干渉パルス抑制 D = 出力の過電流保護および短絡保護	

# Отражательный световой датчик

## Руководство по эксплуатации

### 73 Указания по безопасности

- Перед вводом в эксплуатацию изучите руководство по эксплуатации.
- Подключение, монтаж и установку поручать только специалистам.
- Не является оборудованием для обеспечения безопасности в соответствии с Директивой ЕС по работе с машинным оборудованием.
- UL: Только для использования в областях применения согласно NFPA 79. Эти устройства должны быть защищены предохранителем 1 А, подходящим для 30 В постоянного тока. Доступны адаптеры с соединительными кабелями, перечисленные UL Enclosure type 1
- При вводе в эксплуатацию защищать устройство от попадания грязи и влаги.
- Данное руководство по эксплуатации содержит информацию, которая необходима во время всего жизненного цикла сенсора.

### 74 Использование по назначению

MultiPulse WTB4-3 является оптоэлектронным отражательным световым датчиком (в дальнейшем называемым "сенсор") и используется для оптической бесконтактной регистрации вещей. В случае использования устройства для иных целей, а также в случае внесения в изделие изменений, любые претензии к компании SICK AG на предоставление гарантии исключаются.

отражательный световой датчик с затемнением фона.

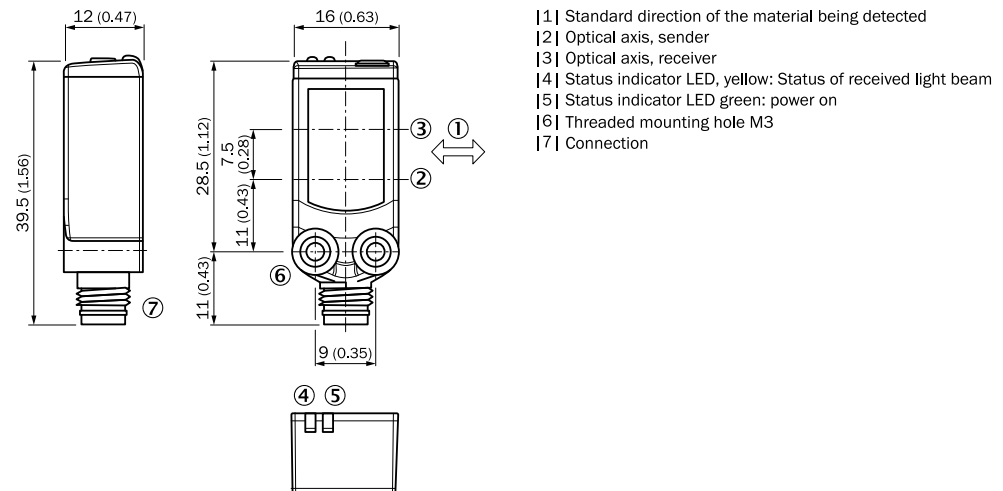

Image: A

### 75 Ввод в эксплуатацию

- 1 Установите сенсор на подходящем крепежном уголке (см. программу принадлежностей от SICK).  
Выдерживайте максимально допустимый момент затяжки сенсора в 0.8 Нм.

- 2 Подключайте сенсоры при отключенном напряжении питания ( $U_V = 0 \text{ В}$ ). В зависимости от типа подключения следует принять во внимание информацию с графиков (см. В):

– Штекерный разъем: назначение контактов

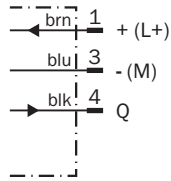

Image: B

Подавайте и включайте источник питания только после завершения подключения всех электрических соединений ( $U_V > 0 \text{ В}$ ). На сенсоре загорается зеленый светодиодный индикатор.

Пояснения к схеме электрических соединений (график В):

MultiPulse WTB4-3P (PNP: нагрузка -> M)

Частота колебаний на выходе составляет 10 Гц, если объект находится в фиксированном диапазоне срабатывания от 30 до 100 мм. Выход отключается, если объект находится в диапазоне от 0 до 30 мм и более 100 мм.

- 3 Направьте сенсор на объект. Выберите такую позицию, чтобы красный луч передатчика попадал в центр объекта. Оптическое отверстие (фронтальное стекло) на сенсоре должно быть полностью свободным [см. E]. Рекомендуется выполнять настройку с объектом пониженной яркости.

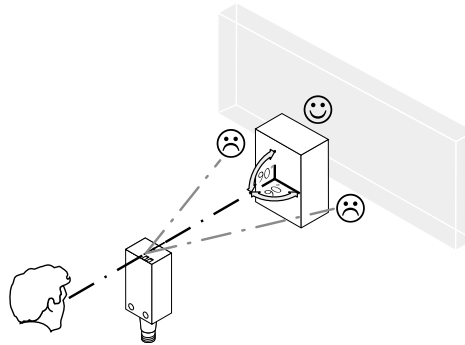

Image: E

- 4 Сенсор без регулировки: сенсор настроен и готов к эксплуатации. Фиксированное расстояние срабатывания составляет от 30 до 100 мм.

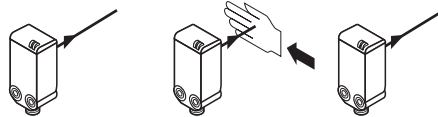

Image: C

## 77 Диагностика неисправностей

В таблице I показано, какие меры нужно предпринять, если сенсоры не работают.

## 78 таблицы диагностики неисправностей

Светодиодный индикатор / картина неисправности / LED indicator/fault pattern	Причина / Cause	Меры по устранению / Measures
зеленый светодиод не горит / Green LED does not light up	нет напряжения питания или оно ниже нижнего предельного значения / No voltage or voltage below the limit values	Проверить напряжения питания, всю схему электроподключения (проводку и разъемные соединения) / Check the power supply, check all electrical connections (cables and plug connections)
зеленый светодиод не горит / Green LED does not light up	Пропадание напряжения питания / Voltage interruptions	Обеспечить надежную подачу напряжения питания без его пропадания / Ensure there is a stable power supply without interruptions
зеленый светодиод не горит / Green LED does not light up	Сенсор неисправен / Sensor is faulty	Если напряжение питания в порядке, то заменить сенсор / If the power supply is OK, replace the sensor
желтый светодиод мигает / Yellow LED flashes	Сенсор пока еще готов к работе, но эксплуатационные условия не оптимальны / Sensor is still ready for operation, but the operating conditions are not ideal	Проверка эксплуатационных условий: Полностью сориентировать световой луч (световое пятно) на объект / чистка оптических поверхностей / заново настроить чувствительность / проверить и, при необходимости, скорректировать расстояние срабатывания, см. график F. / Check the operating conditions: Fully align the beam of light (light spot) with the object. / Clean the optical surfaces. / Readjust the sensitivity / Check sensing range and adjust if necessary; see graphic F.
желтый светодиод горит, объект на пути луча отсутствует / Yellow LED lights up, no object in the path of the beam	Расстояние между сенсором и фоном слишком мало / Distance between the sensor and the background is too short	Уменьшить расстояние срабатывания, см. график F / Reduce the sensing range, see graphic F
Объект на пути луча, желтый светодиод не горит / Object is in the path of the beam, yellow LED does not light up	Слишком большое расстояние между сенсором и объектом или установлена слишком малая дистанция переключения / Distance between the sensor and the object is too long or sensing range is set too short	Увеличить расстояние срабатывания, см. график F / Increase the sensing range, see graphic F

## 79 Демонтаж и утилизация

Утилизацию сенсоров следует проводить согласно национальным предписаниям по утилизации. Следует стремиться к повторному использованию содержащихся в них материалов (прежде всего, драгоценных металлов).

## 80 Техобслуживание

Датчики SICK не нуждаются в техобслуживании.

Рекомендуется регулярно

- очищать оптические ограничивающие поверхности
- проверять прочность резьбовых и штекерных соединений

Запрещается вносить изменения в устройства.

Право на ошибки и внесение изменений сохранено. Указанные свойства изделия и технические характеристики не являются гарантией.

## 81 Технические характеристики

	WTB4-3P2100S14
Расстояние срабатывания	30 ... 100 mm
Расстояние срабатывания, макс.	30 ... 100 mm <sup>41)</sup>
Диаметр светового пятна/расстояние	7 mm / 50 mm
Напряжение питания $U_V$	DC 10 ... 30 V <sup>42)</sup>
Выходной ток $I_{\text{макс.}}$	100 mA
Частота срабатывания макс.	2 Hz <sup>43)</sup>
Время отклика макс.	250 ms <sup>44)</sup>
Класс защиты	IP 67
Класс защиты	III
Схемы защиты	A,C,D <sup>45)</sup>
Диапазон рабочих температур	-40 ... +60 °C
<sup>1)</sup> Сканируемый объект – ремиссия 90 % (относительно стандартного белого по DIN 5033) <sup>2)</sup> Предельные значения: эксплуатация в защищенной от короткого замыкания сети макс. 8 A; остаточная волнистость макс. 5 Bss <sup>3)</sup> Соотношение светлых и темных участков изображения 1:1 <sup>4)</sup> Продолжительность сигнала при омической нагрузке <sup>5)</sup> A = UV-подключения с защитой от перепутывания полюсов C = подавление импульсных помех D = выходы защищены от перенапряжения и короткого замыкания	