

# KTS/KTX Prime

Contrast sensor

Analog input voltage and analog output voltage

**SICK**  
Sensor Intelligence.



### Described product

KTS/KTX Prime analog input voltage and analog output voltage

### Manufacturer

SICK AG  
Erwin-Sick-Str. 1  
79183 Waldkirch  
Germany

### Legal information

This work is protected by copyright. Any rights derived from the copyright shall be reserved for SICK AG. Reproduction of this document or parts of this document is only permissible within the limits of the legal determination of Copyright Law. Any modification, abridgment or translation of this document is prohibited without the express written permission of SICK AG.

The trademarks stated in this document are the property of their respective owner.

© SICK AG. All rights reserved.

### Original document

This document is an original document of SICK AG.



## Contents

<b>1</b>	<b>About this document.....</b>	<b>5</b>
1.1	Information on the operating instructions.....	5
1.2	Scope.....	5
1.3	Explanation of symbols.....	5
1.4	Further information.....	6
1.5	Customer service.....	6
<b>2</b>	<b>Safety information.....</b>	<b>7</b>
2.1	Improper use.....	7
2.2	Intended use.....	7
2.3	Limitation of liability.....	7
2.4	Requirements for skilled persons and operating personnel.....	8
2.5	Hazard warnings and operational safety.....	8
2.6	Repair.....	9
<b>3</b>	<b>Product description.....</b>	<b>10</b>
3.1	Product ID.....	10
3.2	Product features and functions.....	11
<b>4</b>	<b>Mounting.....</b>	<b>15</b>
4.1	Scope of delivery.....	15
4.2	Mounting requirements.....	15
4.3	Mounting the device.....	15
<b>5</b>	<b>Electrical installation.....</b>	<b>17</b>
5.1	Notes on the electrical installation.....	17
5.2	Note on the swivel connector.....	18
5.3	Wiring the interfaces.....	18
5.4	Pin assignment of the connections.....	18
5.5	Connecting the supply voltage.....	18
5.6	Wiring the interfaces.....	19
<b>6</b>	<b>Operation.....</b>	<b>22</b>
6.1	Operating elements.....	22
6.2	Navigation tree, general.....	22
6.3	Navigation tree, PRO level.....	23
6.4	List of abbreviations (type-dependent).....	24
6.5	Activating or deactivating the pushbutton lock.....	25
6.6	Resetting the device (factory setting).....	25
6.7	Pro level (advanced settings).....	26
6.8	Other indicators and functions.....	31
<b>7</b>	<b>Troubleshooting.....</b>	<b>32</b>
7.1	Possible errors during commissioning.....	32
7.2	Possible errors during operation.....	32

<b>8</b>	<b>Maintenance.....</b>	<b>33</b>
8.1	Maintenance.....	33
8.2	Cleaning the device.....	33
<b>9</b>	<b>Decommissioning.....</b>	<b>35</b>
9.1	Disassembly and disposal.....	35
9.2	Returning devices.....	35
<b>10</b>	<b>Technical data.....</b>	<b>36</b>
10.1	General data.....	36
10.2	Dimensional drawings.....	37
<b>11</b>	<b>Accessories.....</b>	<b>39</b>
<b>12</b>	<b>Annex.....</b>	<b>40</b>
12.1	EU declaration of conformity and certificates.....	40
12.2	Certification according to UL 60947-5-2.....	40
12.3	Licenses.....	40

# 1 About this document

## 1.1 Information on the operating instructions

These operating instructions provide important information on how to use devices from SICK AG.

Prerequisites for safe work are:

- Compliance with all safety notes and handling instructions supplied
- Compliance with local work safety regulations and general safety regulations for device applications

The operating instructions are intended to be used by qualified personnel and electrical specialists.



### NOTE

Read these operating instructions carefully before starting any work on the device, in order to familiarize yourself with the device and its functions.

---

The instructions constitute an integral part of the product and are to be stored in the immediate vicinity of the device so they remain accessible to staff at all times. Should the device be passed on to a third party, these operating instructions should be handed over with it.

These operating instructions do not provide information on operating the machine in which the device is integrated. For information about this, refer to the operating instructions of the specific machine.

## 1.2 Scope

These operating instructions serve to incorporate the device into a customer system. Instructions are given by stages for all actions required.

These instructions apply to all listed device variants of the product.

Available device variants are listed on the online product page.

- ▶ [www.sick.com/KTS\\_Prime](http://www.sick.com/KTS_Prime)
- ▶ [www.sick.com/KTX\\_Prime](http://www.sick.com/KTX_Prime)

Commissioning is described using one particular device variant as an example.

### Simplified device designation in the document

In the following, the sensor is referred to in simplified form as “KTS/KTX” or “device.”

## 1.3 Explanation of symbols

Warnings and important information in this document are labeled with symbols. The warnings are introduced by signal words that indicate the extent of the danger. These warnings must be observed at all times and care must be taken to avoid accidents, personal injury, and material damage.



### DANGER

... indicates a situation of imminent danger, which will lead to a fatality or serious injuries if not prevented.

---

**WARNING**

... indicates a potentially dangerous situation, which may lead to a fatality or serious injuries if not prevented.

---

**CAUTION**

... indicates a potentially dangerous situation, which may lead to minor/slight injuries if not prevented.

---

**NOTICE**

... indicates a potentially harmful situation, which may lead to material damage if not prevented.

---

**NOTE**

... highlights useful tips and recommendations as well as information for efficient and trouble-free operation.

---

### 1.4 Further information

**NOTE**

All the documentation available for the device can be found on the online product page at:

- ▶ [www.sick.com/KTS\\_Prime](http://www.sick.com/KTS_Prime)
- ▶ [www.sick.com/KTX\\_Prime](http://www.sick.com/KTX_Prime)

The following information is available for download there:

- Type-specific online data sheets for device variants, containing technical data and dimensional drawings
  - EU declaration of conformity for the product family
  - Dimensional drawings and 3D CAD dimension models in various electronic formats
  - These operating instructions, available in English and German, and in other languages if necessary
  - Other publications related to the devices described here
  - Publications dealing with accessories
- 

### 1.5 Customer service

If you require any technical information, our customer service department will be happy to help. To find your agency, see the final page of this document.

---

**NOTE**

Before calling, make a note of all type label data such as type code, serial number, etc., to ensure faster processing.

---

## 2 Safety information

### 2.1 Improper use

- The device does not constitute a safety-relevant device according to the EC Machinery Directive (2006/42/EC).
- The device must not be used in explosion-hazardous areas.
- Any other use that is not described as intended use is prohibited.
- Any use of accessories not specifically approved by SICK AG is at your own risk.

The device is not suitable for the following applications (this list is not exhaustive):

- As a safety device to protect persons, their hands, or other body parts
- Underwater
- In explosion-hazardous areas
- Outdoors, without additional protection



#### NOTICE

##### **Danger due to improper use!**

Any improper use can result in dangerous situations.

Therefore, observe the following information:

- ▶ The device should be used only in line with intended use specifications.
- ▶ All information in these operating instructions must be strictly complied with.

### 2.2 Intended use

The KTS contrast sensor is an opto-electronic sensor for the optical, non-contact detection of contrasts.

A contrast sensor is designed for mounting and may only be operated according to its intended function. For this reason, it is not equipped with direct safety devices.

The system designer must provide measures to ensure the safety of persons and systems in accordance with the legal guidelines.

SICK AG assumes no liability for losses or damage arising from the use of the product, either directly or indirectly. This applies in particular to use of the product that does not conform to its intended purpose and is not described in this documentation.

### 2.3 Limitation of liability

Applicable standards and regulations, the latest state of technological development, and our many years of knowledge and experience have all been taken into account when assembling the data and information contained in these operating instructions. The manufacturer accepts no liability for damage caused by:

- Failure to observe the operating instructions
- Improper use
- Use by untrained personnel
- Unauthorized conversions
- Technical modifications
- Use of unauthorized spare parts, wear and tear parts, and accessories

With special variants, where optional extras have been ordered, or owing to the latest technical changes, the actual scope of delivery may vary from the features and illustrations shown here.

## 2.4 Requirements for skilled persons and operating personnel



### WARNING

#### Risk of injury due to insufficient training!

Improper handling of the device may result in considerable personal injury and material damage.

- All work must only ever be carried out by the stipulated persons.

The operating instructions state the following qualification requirements for the various areas of work:

- **Instructed personnel** have been briefed by the operating entity about the tasks assigned to them and about potential dangers arising from improper action.
- **Skilled personnel** have the specialist training, skills, and experience, as well as knowledge of the relevant regulations, to be able to perform tasks assigned to them and to detect and avoid any potential dangers independently.
- **Electricians** have the specialist training, skills, and experience, as well as knowledge of the relevant standards and provisions to be able to carry out work on electrical systems and to detect and avoid any potential dangers independently. In Germany, electricians must meet the specifications of the DGUV V3 Work Safety Regulations (e.g., Master Electrician). Other relevant regulations applicable in other countries must be observed.

The following qualifications are required for various activities:

Activities	Qualification
Mounting, maintenance	<ul style="list-style-type: none"> <li>■ Basic practical technical training</li> <li>■ Knowledge of the current safety regulations in the workplace</li> </ul>
Electrical installation, device replacement	<ul style="list-style-type: none"> <li>■ Practical electrical training</li> <li>■ Knowledge of current electrical safety regulations</li> <li>■ Knowledge of the operation and control of the devices in their particular application</li> </ul>
Commissioning, configuration	<ul style="list-style-type: none"> <li>■ Basic knowledge of the design and setup of the described connections and interfaces</li> <li>■ Basic knowledge of data transmission</li> <li>■ Knowledge of the operation and control of the devices in their particular application</li> </ul>
Operation of the devices in their particular application	<ul style="list-style-type: none"> <li>■ Knowledge of the operation and control of the devices in their particular application</li> <li>■ Knowledge of the software and hardware environment in the application</li> </ul>

## 2.5 Hazard warnings and operational safety

Please observe the safety notes and the warnings listed here and in other chapters of these operating instructions to reduce the possibility of risks to health and avoid dangerous situations.

### 2.5.1 Eye safety



### CAUTION

The device is equipped with LEDs. The device meets the criteria of risk group 1 according to IEC 62471:2006. No special measures are required (e.g., eye protection).



## 2.6 Repair

The product is a replacement device. The device is not intended to be repaired. Interference with or modifications to the device on the part of the customer will invalidate any warranty claims against SICK AG.

## 3 Product description

### 3.1 Product ID

#### 3.1.1 Type label

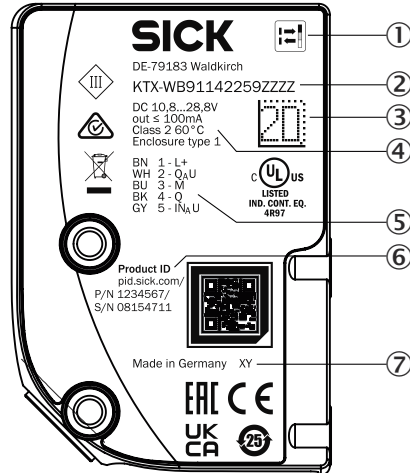

Figure 1: Type label using the example of the KTX Prime

- ① Contrast sensor pictogram
- ② Device type number
- ③ 2D code
- ④ Electrical data and environmental data
- ⑤ Pin assignment
- ⑥ Product ID
- ⑦ Date of manufacture

#### 3.1.2 Type code

1	2	-	3	4	5	6	7	8	9	10	11	12	13
KT	X		W	B	9	1	1	4	1	2	5	9	Z

Position	Meaning	
1	Basic type	KT = contrast sensor
2	Form factor/housing size	S = small X = large
3	Light sender	W = RGB
4	Switching output	B = push/pull N = NPN P = PNP
5	Function	9 = Prime (1-point, 2-point, dynamic teach-in and automated switching threshold)
6	Light spot direction	1 = longitudinal 2 = transverse 4 = round
7	Sensing distance	1 = sensing distance 13 mm 2 = sensing distance 25 mm
8	Filtering	4 = no filter

Position	Meaning	
9	Light emission	1 = long side 2 = short side
10	Operation	1 = long side 2 = short side
11	Connection type	4 = M12, male connector, 4-pin 5 = M12, male connector, 5-pin
12	Communication	2 = no communication A = IO-Link I = analog output (current) U = analog output (voltage) 9 = analog output (voltage) and analog input (voltage)
13	Device type	M = sample device S = special device F = private label A = automation function B = special device with automation function C = reserved Z = standard

### 3.2 Product features and functions

#### 3.2.1 Device view

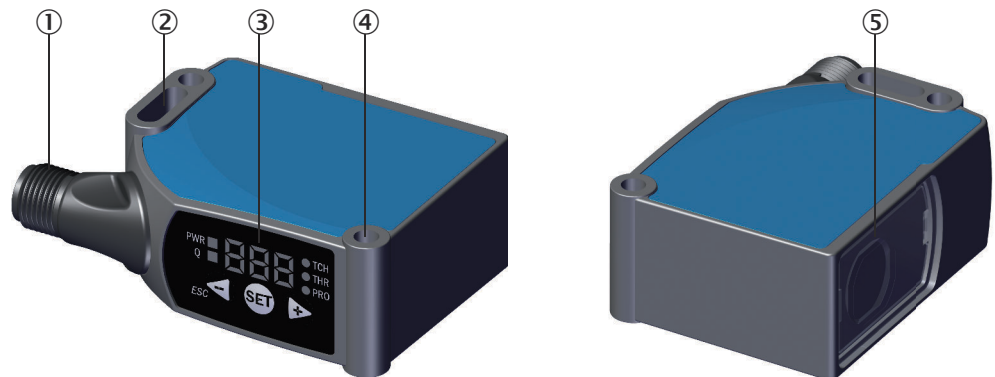

Figure 2: KTS Prime light emission long housing side

- ① Connection
- ② Mounting slot
- ③ Display and control panel
- ④ Fixing hole
- ⑤ Light emission

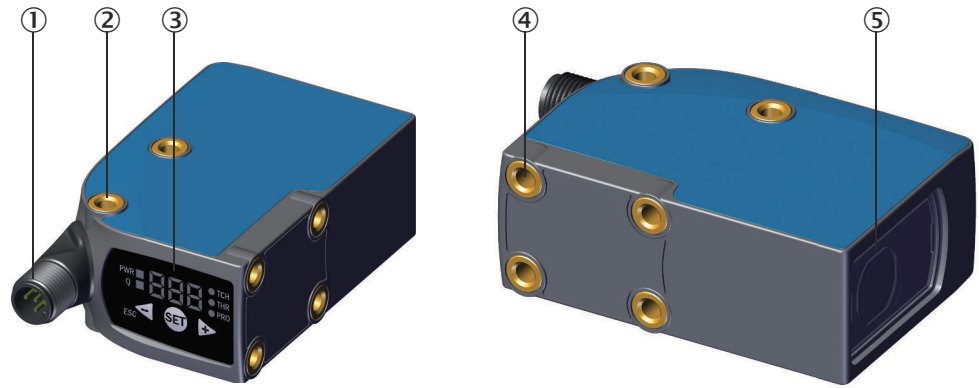

Figure 3: KTX Prime light emission short housing side

- ① Connection
- ② M5 mounting thread
- ③ Display and control panel
- ④ M5 mounting thread
- ⑤ Light emission

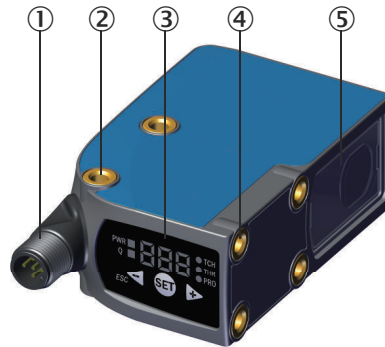

Figure 4: KTX Prime light emission long housing side

- ① Connection
- ② M5 mounting thread
- ③ Display and control panel
- ④ M5 mounting thread
- ⑤ Light emission

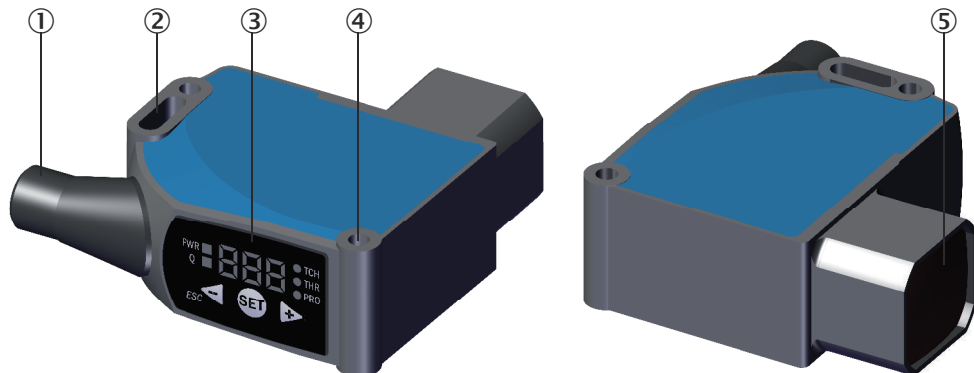

Figure 5: KTS Prime long sensing range light emission long housing side

- ① Connection
- ② Mounting slot
- ③ Display and control panel

- ④ Fixing hole
- ⑤ Light emission

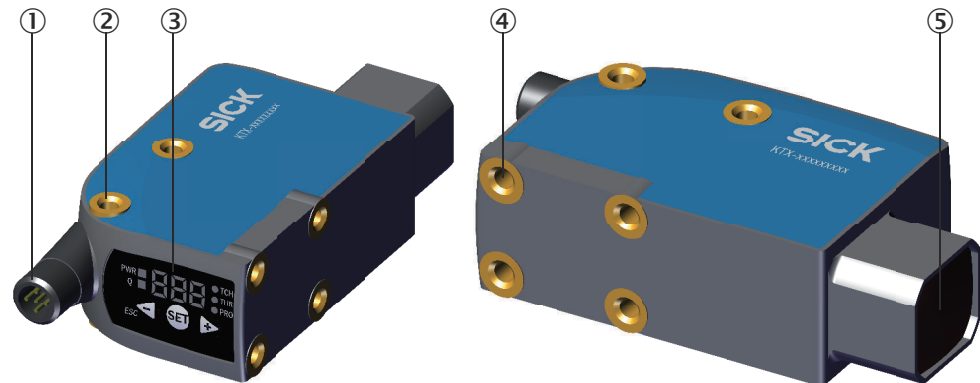

Figure 6: KTX Prime long sensing range light emission short housing side

- ① Connection
- ② M5 mounting thread
- ③ Display and control panel
- ④ M5 mounting thread
- ⑤ Light emission

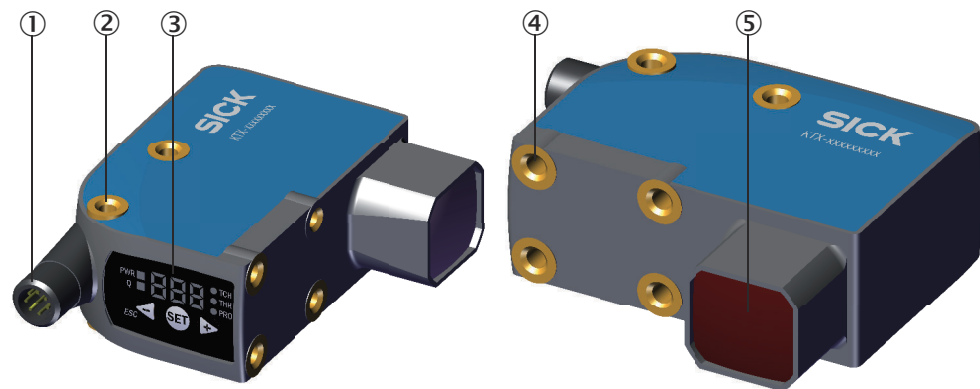

Figure 7: KTX Prime long sensing range light emission long housing side

- ① Connection
- ② M5 mounting thread
- ③ Display and control panel
- ④ M5 mounting thread
- ⑤ Light emission

### 3.2.2 Product characteristics

Contrast sensors are primarily used in packaging or printing machines for detecting marks.

However, they can also be used in any application based on making a distinction between contrasts.

KTS/KTX contrast sensors detect even the smallest contrasts at the highest speeds, such as print marks on foils or packaging. They detect minute grayscale variations between the mark and the background on matte, shiny, or transparent surfaces. Device types are available with different methods of contrast resolution and different teach-in variants for a wide range of requirements.

### Features

- TwinEye technology® for increased depth of field and sensing distance tolerance
- 50 kHz switching frequency
- Large dynamic range means reliable detection of contrasts on glossy materials
- 7-segment display
- Color mode
- Mounting feedback
- IO-Link and Smart Tasks
- Flexible sensor setting thanks to various sensor parameters

### Fields of application

- Applications in which contrast or color is a basic distinguishing feature
- Print mark detection for controlling the cutting process
- Print control in the print and paper industry
- Positioning of tubes when filling
- Label alignment on bottles
- Monitoring of wafer surfaces
- Roll end monitoring
- Color control in yarn or line production

## 4 Mounting

### 4.1 Scope of delivery

- Contrast sensor in the version ordered
- Quickstart
- Safety notes

### 4.2 Mounting requirements

- Typical space requirement for the device, see type-specific dimensional drawing, see ["Technical data", page 36](#).
- Comply with technical data, such as the permitted ambient conditions for operation of the device (e.g., temperature range, EMC interference emissions, ground potential).
- To prevent condensation, avoid exposing the device to rapid changes in temperature.
- Protect the device from direct sunlight.
- The device must only be mounted using the pairs of mounting threads/fixing holes provided for this purpose.
- Shock and vibration-free mounting.

### 4.3 Mounting the device

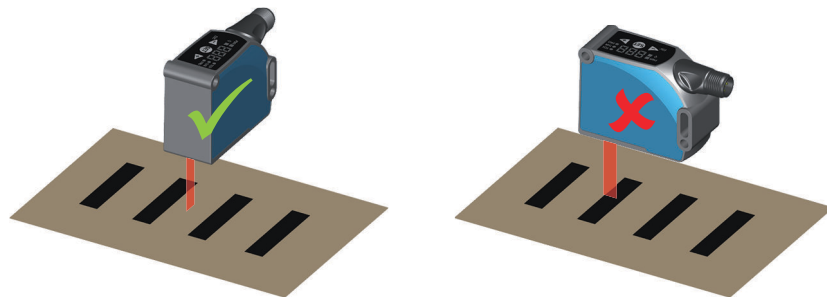

Figure 8: KTS Prime

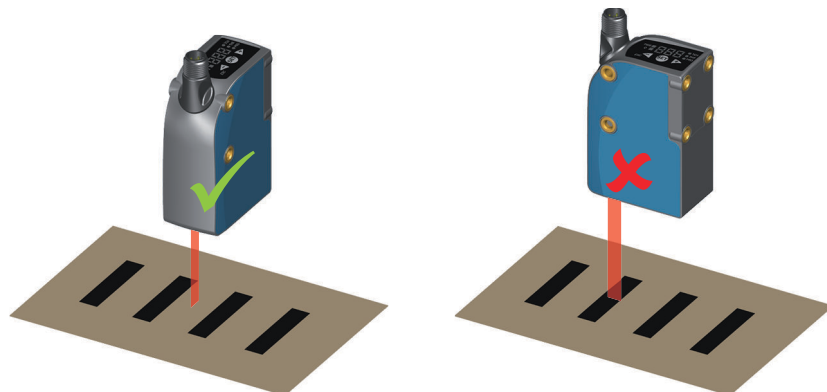

Figure 9: KTX Prime light emission short housing side

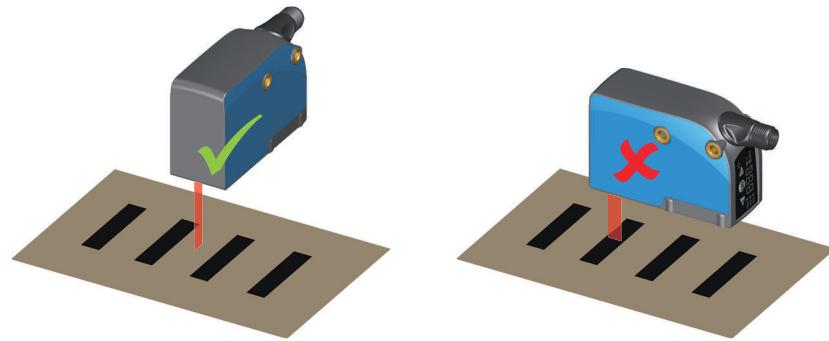

Figure 10: KTX Prime light emission long housing side

1. The adjustment quality is automatically shown in the display as mounting feedback during the first device initialization. To do so, the device must be brought within the nominal sensing distance manually, ideally on light material (see data sheet). Pay attention to the figure during alignment. After adjustment, quit the process with any pushbutton.
2. Install the device via the fixing hole so that the light spot enters the mark longitudinally and the test object has the least possible vertical and horizontal movement. Note the sensing distance while doing so.
3. Compensate for the vertical and horizontal movement of the test object by marks of suitable lengths.
4. Ensure that any device movement does not affect the sensing distance.

**Mounting feedback**



**NOTE**

Assembly feedback (AdJ) is only available for standard variants with a sensing distance of 13 mm and 25 mm.

Table 1: Mounting feedback indicator

	<p>Sensing distance set too close or too far away.</p>
	<p>Sensing distance set within the detection range, but not at the optimum level.</p>
	<p>Nominal sensing distance set.</p>

To secure a stable detection when having high gloss material a tilt angle of 10°-15° might be necessary.



## 5 Electrical installation

### 5.1 Notes on the electrical installation



#### NOTICE

##### Device damage due to incorrect supply voltage!

An incorrect supply voltage may result in damage to the device.

- Only operate the device with safety/protective extra-low voltage (SELV/PELV).
- The sensor is a device of protection class III.



#### NOTICE

##### Device damage due to incorrect supply voltage!

An incorrect supply voltage may result in damage to the device.

- Only operate the device with an LPS (limited power source) in accordance with IEC 62368-1 or an NEC Class 2 power supply unit.



#### NOTICE

##### Device damage or unpredictable operation due to working with live parts!

Working with live parts may result in unpredictable operation.

- Only carry out wiring work when the power is off.
- Only connect and disconnect electrical connections when the power is off.

- **The electrical installation must only be performed by electrically qualified personnel.**
- **Standard safety requirements must be met when working on electrical systems!**
- Only switch on the supply voltage for the device when the connection tasks have been completed and the wiring has been thoroughly checked.
- When using extension cables with open ends, ensure that bare wire ends do not come into contact with each other (risk of short-circuit when supply voltage is switched on!). Wires must be appropriately insulated from each other.
- Wire cross-sections in the supply cable from the user's power system must be selected in accordance with the applicable standards.
- Only operate the device with an LPS (limited power source) in accordance with IEC 62368-1 or an NEC Class 2 power supply unit.
- All circuits connected to the device must be designed as SELV/PELV circuits.
- Operation in short-circuit protected network at max. 8 A.



#### NOTE

##### Layout of data cables

- Use screened data cables with twisted-pair wires.
- Implement the screening design correctly and completely.
- To avoid interference, e.g., from switching power supplies, motors, clocked drives, and contactors, always use cables and layouts that are suitable for EMC.
- Do not lay cables over long distances in parallel with voltage supply cables and motor cables in cable channels.

The IP enclosure rating for the device is only achieved under the following conditions:

- The cables plugged into the connections are screwed tight.

If these instructions are not complied with, the IP enclosure rating for the device is not guaranteed!

## 5.2 Note on the swivel connector



### NOTICE

#### Damage to the connector unit from over-tightening!

The connector unit on the device has two opposite end positions.

- Do not rotate the connector unit from either of the two end positions by more than 270°.

## 5.3 Wiring the interfaces

## 5.4 Pin assignment of the connections

### Overview of pin assignment

Table 2: M12 male connector, 5-pin

	2-P	1-P	dyn.	AUTO
1	L+	L+	L+	L+
2	Q <sub>A</sub> U	Q <sub>A</sub> U	Q <sub>A</sub> U	Q <sub>A</sub> U
3	M	M	M	M
4	Q	Q	Q	Q
5	IN <sub>A</sub> U	IN <sub>A</sub> U	IN <sub>A</sub> U	IN <sub>A</sub> U

### Legend

L+ = supply voltage

Q<sub>A</sub>U = voltage output

M = ground

Q = switching output

IN<sub>A</sub> U = analog input voltage

## 5.5 Connecting the supply voltage



### NOTICE

#### Risk of damage to the device!

The device can become damaged if it is connected to a voltage supply that is already switched on.

- Only connect the device when the supply cable is de-energized.

The device must be connected to a power supply unit with the following properties:

- Supply voltage DC 10,8 V – 28,8 V (SELV/PELV as per currently valid standards)
- Electricity source with at least 4 W power

To ensure protection against short-circuits/overload in the customer's supply cables, the wire cross-sections used must be appropriately selected and protected.

## 5.6 Wiring the interfaces

### 5.6.1 Wiring the analog input

The analog input is used to adjust the switching threshold of the device. The applied voltage scales to the remission value.

#### Electrical values

Remission min.: 0 V

Remission max.: 10 V



#### NOTE

If no voltage is applied at the analog input (0 V), the sensor is already switching to the lowest remissions of the object.

### 5.6.2 Wiring the analog output

The analog output issues the remission value of the mark or the background to the control.

The remission value is output as a scaling voltage.

#### Electrical values

Remission min.: 0 V

Remission max.: 10 V

### 5.6.3 Wiring the digital outputs

The number of digital outputs available at the connections will vary, depending on the device, see "[Pin assignment of the connections](#)", page 18. If the allocated event occurs in the read process, then the corresponding digital output is live.

In each case, the digital outputs are short-circuit protected and overcurrent protected.

Switching behavior: PNP or NPN or push/pull

#### Electrical values

The sum current (100 mA) for all digital outputs is identical.

**PNP HIGH:**  $U_V - 3\text{ V}$ ; **LOW:** 0 V

**NPN HIGH:**  $U_V$ ; **LOW:**  $\leq 3\text{ V}$

**Push/pull HIGH:**  $U_V - 3\text{ V}$ ; **LOW:**  $\leq 3\text{ V}$

In the case of a push/pull sensor, the signal must be inverted in the control system in order to obtain the same result as a sensor with NPN switching behavior.

Table 3: Push-Pull

	 <p>PWR ■ Q ■</p>	 <p>PWR ■ Q □</p>
Q push-pull (≤ 100 mA)	 <p>+ (L+) Q - (M)</p>	 <p>+ (L+) Q - (M)</p>

Table 4: PNP

	 <p>PWR ■ Q ■</p>	 <p>PWR ■ Q □</p>
Q PNP (≤ 100 mA)	 <p>+ (L+) Q - (M)</p>	 <p>+ (L+) Q - (M)</p>

Table 5: NPN

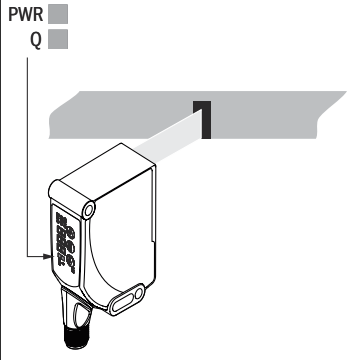
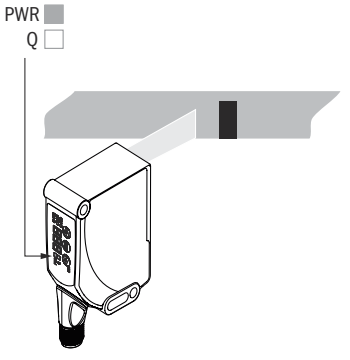
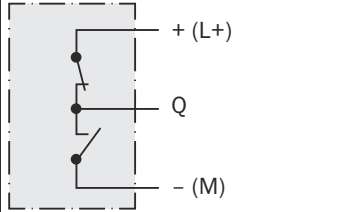
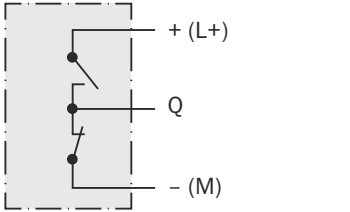

## 6 Operation

### 6.1 Operating elements

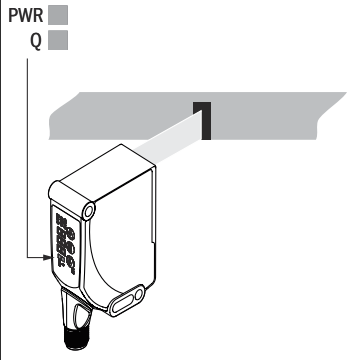
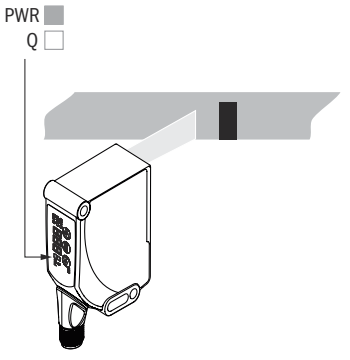
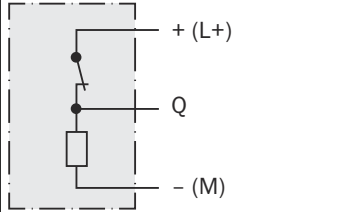
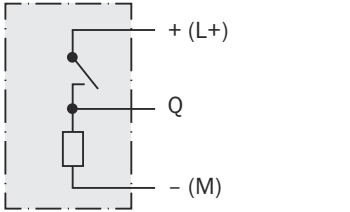
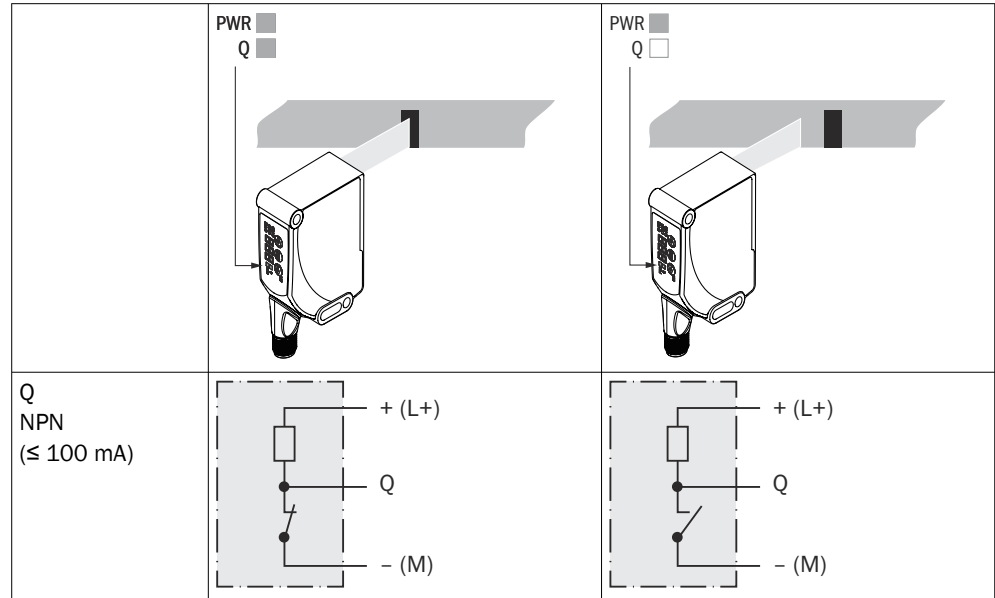
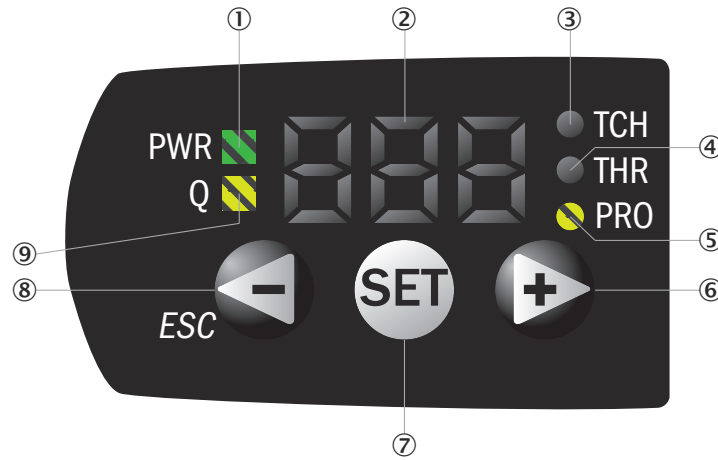
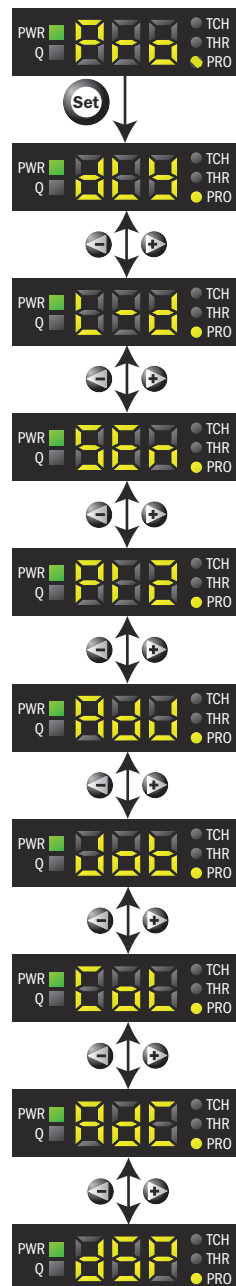

Table 6: Operating elements legend

Number	Description	Function
1	PWR	Illuminates when the voltage supply is connected.
2	Segment display	Shows menu item, values, or qualities.
3	TCH	Cannot be selected.
4	THR	Cannot be selected.
5	PRO	Illuminates when the “advanced settings” menu is selected.
6	Plus	Scrolls through menu items or increases values.
7	SET	Opens the menu, confirms entries, or switches to lower-level menus.
8	Minus/ESC	Switches to the previous menu item, decreases values, or cancels the current operation (press for > 3 s).
9	Q	Illuminates when there is a switching event.

### 6.2 Navigation tree, general

To leave the current menu level, press and hold the minus pushbutton for > 3 seconds.



### 6.3 Navigation tree, PRO level

To leave the current menu level, press and hold the minus pushbutton for > 3 seconds.



### 6.4 List of abbreviations (type-dependent)

Table 7: List of abbreviations

Display	Meaning
1P	1-point teach-in
1St	First teach point
2nd	Second teach point
2P	2-point teach-in
A90	Time stamp
AdC	Contamination tracking
AdJ	Alignment
AFc	Automatic function
At	Blanking
AUt	Automated
bIU	Blue
bSY	Busy
CoL	Color
CoA	Coarse
dAr	Dark
dIY	Delay
dSP	Display switch
dYn	Dynamic teach-in
Err	Error
F-C	Fine/coarse



Display	Meaning
FIn	Fine
GrE	Green
Job	Parameter sets
Jo1	Parameter set 1
Jo2	Parameter set 2
Jo3	Parameter set 3
Jo4	Parameter set 4
Jo5	Parameter set 5
L-d	Light/dark
LGt	Light
LoA	Load
LoC	Locked
Mdl	Middle
nF	No function
oFF	Off
OUT	Output
PI1	Pin 1 configuration
PI2	Pin 2 configuration
PI5	Pin 5 configuration
Pro	Pro level (advanced settings)
rEd	Red
rES	Reset
Sen	Sensitivity
Sto	Store
tch	Teach-in
thr	Threshold
toF	Timer – OFF delay
ton	Timer – ON delay
tP	Pulse generator
tSh	Switch-on/switch-off delay (on/off delay)
tur	Turn (display)

## 6.5 Activating or deactivating the pushbutton lock

1. Press and hold the plus pushbutton for 10 seconds.



2. The pushbutton lock is active or deactivated.

## 6.6 Resetting the device (factory setting)

1. Press and hold the plus and minus pushbuttons for 10 s.



- The set parameters are reset to the factory settings.

## 6.7 Pro level (advanced settings)

You can use the advanced settings to adapt the device to the particular application conditions or to configure additional values and functions.

### 6.7.1 Adjusting the switching logic (light/dark)

The “AUTO” switching logic is preset (factory setting). Light or dark switching is detected automatically by the sensor.

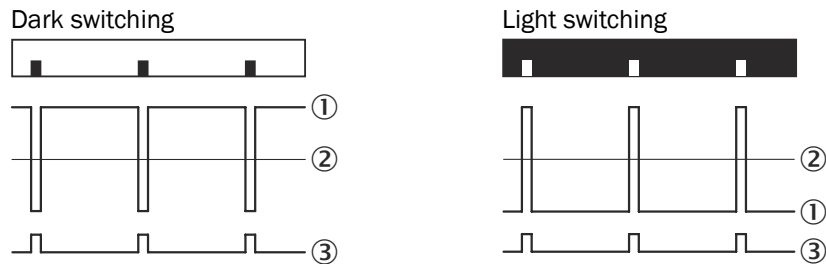

- ① Internal received signal
- ② Switching threshold
- ③ Output Q

- Press the SET pushbutton.
- Use the plus or minus pushbutton to select Pro.



- Press SET.
- Use the plus or minus pushbutton to select L-d.



- Press SET.
- Use the plus or minus pushbutton to select the required setting.



- Press SET.

### 6.7.2 Setting the switch-on and switch-off delay

- Press the SET pushbutton.
- Use the plus or minus pushbutton to select Pro and press the SET pushbutton.



3. Press the SET pushbutton.
4. Use the plus or minus pushbutton to select dLY.



5. Press the SET pushbutton.

#### Setting the switch-on delay

1. Use the plus or minus pushbutton to select ton.



2. Press the SET pushbutton.
3. Use the plus or minus pushbutton to select the switch-on delay in milliseconds in the range 1 – 500.  
Press and hold the pushbutton to increase or reduce the values rapidly.



4. Press the SET pushbutton.

#### Setting the switch-off delay

1. Use the plus or minus pushbutton to select toF.



2. Press the SET pushbutton.
3. Use the plus or minus pushbutton to select the switch-off delay in milliseconds in the range 1 – 500.



4. Press the SET pushbutton.

#### Setting the switch-on and switch-off delay (shift)

1. Use the plus or minus pushbutton to select tSh.



2. Press the SET pushbutton.
3. Use the plus or minus pushbutton to select the switch-on delay in milliseconds in the range 1 – 500.



4. Press the SET pushbutton.

#### Adjusting the pulse generator

1. Use the plus or minus pushbutton to select tP.



2. Press the SET pushbutton.
3. Use the plus or minus pushbutton to select the duration of the pulse in milliseconds in the range 1 – 500.



4. Press the SET pushbutton.

#### 6.7.3 Adjusting the switching sensitivity

The contrast differences that have been taught are stored with a tolerance range. The magnitude of the tolerance range can be set to one of three values (sensitive, standard, and reliable).

1. Press the SET pushbutton.
2. Use the plus or minus pushbutton to select Pro.



3. Press the SET pushbutton.
4. Use the plus or minus pushbutton to select SEN.



5. Press the SET pushbutton.
6. Use the plus or minus pushbutton to select the required setting.



Sensitive



Standard (factory setting)



Reliable

7. Press the SET pushbutton.

### 6.7.4 Using mounting feedback



**NOTE**

Assembly feedback (Adj) is only available for standard variants with a sensing distance of 13 mm and 25 mm.

1. Press the SET pushbutton.
2. Use the plus or minus pushbutton to select Pro.



3. Press the SET pushbutton.
4. Use the plus or minus pushbutton to select Adj.



5. Press the SET pushbutton.
6. Adjust the device height manually.



7. Press the SET pushbutton when the device is positioned within the nominal sensing distance.

Table 8: Mounting feedback indicator

Indications	Meaning
	Sensing distance set too close or too far away
	Sensing distance set to moderate

Indications	Meaning
	Nominal sensing distance

### 6.7.5 Adjusting the color fixation

You can use the color fixation to restrict the light source to one particular sender color (red, green, or blue). In the factory setting, the sender color is set to green.

1. Press the SET pushbutton.
2. Use the plus or minus pushbutton to select Pro.



3. Press the SET pushbutton.
4. Use the plus or minus pushbutton to select CoL.



5. Press the SET pushbutton.
6. Use the plus or minus pushbutton to select Sender color.



Sender color red

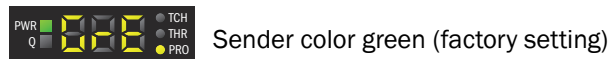

Sender color green (factory setting)



Sender color blue

7. Press the SET pushbutton.

### 6.7.6 Rotating the display

If the installation position of the device makes it difficult to read from the segment display, the display can be rotated 180°.

1. Press the SET pushbutton.
2. Use the plus or minus pushbutton to select Pro.



3. Press the SET pushbutton.
4. Use the plus or minus pushbutton to select dSP.



5. Press the SET pushbutton.



- Use the plus or minus pushbutton to select the direction in which the segment display points.



- Press the SET pushbutton.

## 6.8 Other indicators and functions

### Control panel locked



If the device is undergoing an internal process (e.g., reading or storing parameter sets or teaching in via IO-Link), the control panel is locked and the device shows “bSY” on the segment display.

### Short-circuit and overcurrent detection



In the event of a short-circuit, Err appears on the display and the Q LED flashes.

### Live measured value (run mode)

In run mode, the device displays the remission value currently being measured as a digit.



Table 9: Remission value indicator

Value	Remission value
0	No remission
400	White
999	Maximum remission, with glossy material

### Display standby



#### NOTE

Control panel standby mode is not activated while an error message is displayed.

If no settings are made on the device for 5 minutes, standby mode is activated to save electricity. The settings made, but not confirmed, are not adopted.

To quit standby mode, one of the operating keys must be pushed.

## 7 Troubleshooting

### 7.1 Possible errors during commissioning

Table 10: Troubleshooting during commissioning

Display, error situation	Cause	Measure
<ul style="list-style-type: none"> <li>• “Err” flashes</li> <li>• Q LED (yellow) flashes</li> </ul>	<ul style="list-style-type: none"> <li>• Short-circuit message/overcurrent message</li> <li>• Sensor is not connected properly</li> </ul>	<ul style="list-style-type: none"> <li>• Disconnect sensor from the power network</li> <li>• Check pin assignment</li> <li>• Reconnect sensor</li> <li>• Check the current at the switching output</li> </ul>
No change to the segment display in Mounting feedback mode	<ul style="list-style-type: none"> <li>• Distance between the sensor and the background is too large or too small</li> <li>• Light emission (optics) is dirty</li> </ul>	<ul style="list-style-type: none"> <li>• Clean sensor</li> <li>• Check the application conditions</li> <li>• Restart adjustment process</li> </ul>

### 7.2 Possible errors during operation

Table 11: Troubleshooting during operation

Display, error situation	Cause	Measure
Busy	Sensor is undergoing an internal process.	Wait until the process has finished.
No switching output any more	<ul style="list-style-type: none"> <li>• Distance or angle to material not consistent</li> <li>• Light emission (optics) is dirty</li> </ul>	<ul style="list-style-type: none"> <li>• Clean sensor</li> <li>• Readjust sensor</li> <li>• Check parameter settings</li> </ul>



## 8 Maintenance

### 8.1 Maintenance

During operation, the device works maintenance-free.

Depending on the assignment location, the following preventive maintenance tasks may be required for the device at regular intervals:

Table 12: Maintenance schedule

Maintenance work	Interval	Implementation
Clean housing and front screen	Cleaning interval depends on ambient conditions and climate	Specialist
Check screw connections and plug connectors	Every 6 months	Specialist

### 8.2 Cleaning the device

At regular intervals (e.g., weekly), check the light emission window and the housing of the device for dirt. This is especially relevant in harsh operating environments (dust, abrasion, damp, fingerprints, etc.). The lens of the light emission window must be kept clean and dry during operation.



#### NOTICE

##### Device damage due to improper cleaning!

Improper cleaning may result in device damage.

- Only use suitable cleaning agents.
- Never use sharp objects for cleaning.

#### Cleaning the light emission window



#### NOTICE

##### Damage to the light emission window!

Reduced reading performance due to scratches or streaks on the light emission window!

- ▶ Clean the light emission window only when wet.
- ▶ Use a mild cleaning agent that does not contain powder additives. Do not use aggressive cleaning agents, such as acetone, etc.
- ▶ Avoid any movements that could cause scratches or abrasions on the light emission window.
- ▶ Only use cleaning agents suitable for the lens material.



#### NOTE

Static charge may cause dust particles to stick to the light emission window. This effect can be avoided by using an anti-static glass cleaner in combination with the SICK lens cloth (can be obtained from [www.sick.com](http://www.sick.com)).



#### NOTE

If the light emission window is scratched or damaged (cracked or broken), the device must be replaced. Contact SICK Service to arrange this.

### **Cleaning the housing**

In order to ensure that the heat produced by the internal power loss is adequately dissipated, the housing surface must be kept clean.

## 9 Decommissioning

### 9.1 Disassembly and disposal

#### Disassembling the device

1. Switch off the supply voltage to the device.
2. Detach all connecting cables from the device.
3. If the device is being replaced, mark its position and alignment on the bracket or surroundings.
4. Detach the device from the bracket.

#### Disposing of the device

Any device which can no longer be used must be disposed of in an environmentally friendly manner in accordance with the applicable country-specific waste disposal regulations.



#### NOTE

##### Disposal of batteries, electric and electronic devices

- According to international directives, batteries, accumulators and electrical or electronic devices must not be disposed of in general waste.
- The owner is obliged by law to return this devices at the end of their life to the respective public collection points.



■ This symbol on the product, its package or in this document, indicates that a product is subject to these regulations.

### 9.2 Returning devices

- ▶ Do not dispatch devices to the SICK Service department without consultation.



#### NOTE

To enable efficient processing and allow us to determine the cause quickly, please include the following when making a return:

- Details of the contact person
- Description of the application
- Description of the fault that occurred

## 10 Technical data

### 10.1 General data

Table 13: Technical data

Attribute	Value	
Sensing distance	13 mm	25 mm
Sensing distance tolerance	±5 mm	±6 mm
Light spot size/light spot direction	longitudinal: 3.8 mm x 0.9 mm transverse: 0.9 mm x 3.8 mm round: 0.9 mm <sup>2</sup>	longitudinal: 5.3 mm x 1.2 mm transverse: 1.2 mm x 5.3 mm
Supply voltage <sup>1</sup>	10.8 V – 28.8 V	
Switching frequency	50 kHz	
Response time	10 µs	
Jitter	5 µs	
Switching type	PNP or NPN or push/pull	
Switching output	PNP: HIGH = U <sub>V</sub> - 3 V / LOW = 0 V NPN: HIGH = U <sub>V</sub> / LOW ≤ 3 V Push/pull: HIGH = U <sub>V</sub> - 3 V / LOW ≤ 3 V	
Initialization time	< 150 ms	
Enclosure rating	IP 67	
Ambient temperature (operation)	-20 °C ... +60 °C	
Ambient temperature (UL)	max. 60 °C	
Ambient temperature (storage)	-25 °C ... +75 °C	
Protection class	III	
Circuit protection	U <sub>V</sub> connections, reverse polarity protected, output Q short-circuit protected, interference-pulse suppression	
Switching output	PNP: HIGH = U <sub>V</sub> - 3 V / LOW = 0 V NPN: HIGH = U <sub>V</sub> / LOW ≤ 3 V B (push/pull): HIGH = U <sub>V</sub> - 3 V / LOW ≤ 3 V	
Max. output current of the switching output	100 mA	
Min. resistance at U analog	1000 Ω	
U analog output measured values at white 95%	2 V (= 400 digits)	
U analog output	0 ... 10 V	
Analog input (remote control)	0 ... 10 V	

<sup>1</sup> Operation in short-circuit protected network max. 8 A

## 10.2 Dimensional drawings

### KTS Prime

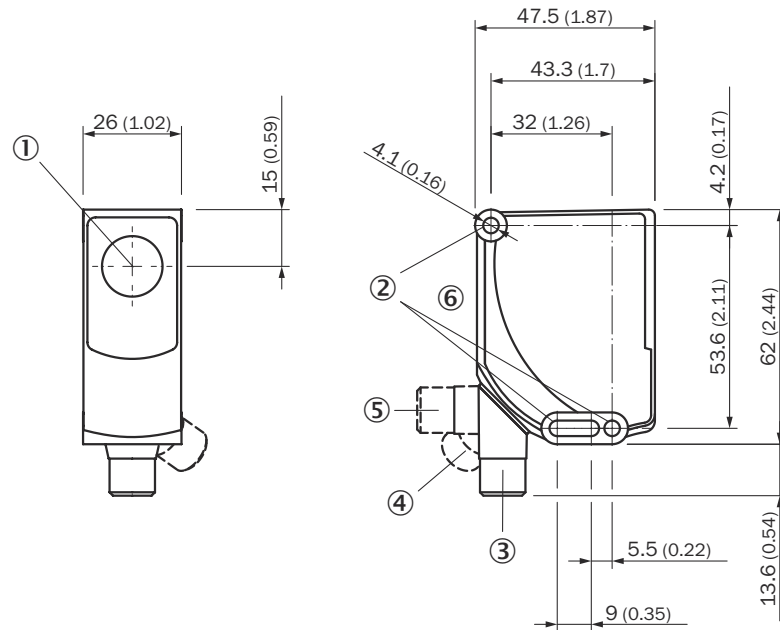

Figure 11: KTS Prime

- ① Optical axis
- ② Fixing hole
- ③ Connector M12, as-delivery state
- ④ Connector M12, mechanical stop rechts
- ⑤ Connector M12, mechanical stop left
- ⑥ Control panel

### KTX Prime

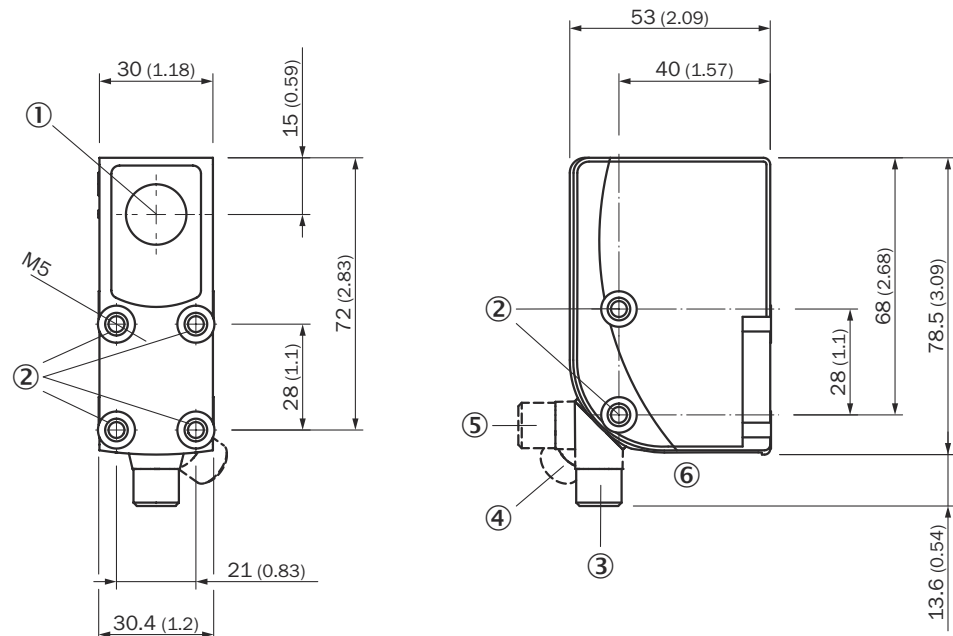

Figure 12: KTX Prime

- ① Optical axis

- ② M5 threaded mounting hole
- ③ Connector M12, as-delivery state
- ④ Connector M12, mechanical stop rechts
- ⑤ Connector M12, mechanical stop left
- ⑥ Control panel

## **11** Accessories



---

**NOTE**

Accessories can be found on the online product page at:

- ▶ [www.sick.com/KTS\\_Prime](http://www.sick.com/KTS_Prime)
  - ▶ [www.sick.com/KTX\\_Prime](http://www.sick.com/KTX_Prime)
-

### 12 Annex

#### 12.1 EU declaration of conformity and certificates

The EU declaration of conformity and other certificates can be downloaded from the Internet at:

- ▶ [www.sick.com/KTS\\_Prime](http://www.sick.com/KTS_Prime)
- ▶ [www.sick.com/KTX\\_Prime](http://www.sick.com/KTX_Prime)

#### 12.2 Certification according to UL 60947-5-2

The contrast sensors of the KTS/KTX Prime and KTS Core series are certified in accordance with UL 60947-5-2 if they are supplied with power by LPS or Class 2 power supply units.

The certification is only valid with corresponding device identification on the type label of the respective device.

#### 12.3 Licenses





**Australia**

Phone +61 (3) 9457 0600  
1800 33 48 02 – tollfree  
E-Mail sales@sick.com.au

**Austria**

Phone +43 (0) 2236 62288-0  
E-Mail office@sick.at

**Belgium/Luxembourg**

Phone +32 (0) 2 466 55 66  
E-Mail info@sick.be

**Brazil**

Phone +55 11 3215-4900  
E-Mail comercial@sick.com.br

**Canada**

Phone +1 905.771.1444  
E-Mail cs.canada@sick.com

**Czech Republic**

Phone +420 234 719 500  
E-Mail sick@sick.cz

**Chile**

Phone +56 (2) 2274 7430  
E-Mail chile@sick.com

**China**

Phone +86 20 2882 3600  
E-Mail info.china@sick.net.cn

**Denmark**

Phone +45 45 82 64 00  
E-Mail sick@sick.dk

**Finland**

Phone +358-9-25 15 800  
E-Mail sick@sick.fi

**France**

Phone +33 1 64 62 35 00  
E-Mail info@sick.fr

**Germany**

Phone +49 (0) 2 11 53 010  
E-Mail info@sick.de

**Greece**

Phone +30 210 6825100  
E-Mail office@sick.com.gr

**Hong Kong**

Phone +852 2153 6300  
E-Mail ghk@sick.com.hk

**Hungary**

Phone +36 1 371 2680  
E-Mail ertesites@sick.hu

**India**

Phone +91-22-6119 8900  
E-Mail info@sick-india.com

**Israel**

Phone +972 97110 11  
E-Mail info@sick-sensors.com

**Italy**

Phone +39 02 27 43 41  
E-Mail info@sick.it

**Japan**

Phone +81 3 5309 2112  
E-Mail support@sick.jp

**Malaysia**

Phone +603-8080 7425  
E-Mail enquiry.my@sick.com

**Mexico**

Phone +52 (472) 748 9451  
E-Mail mexico@sick.com

**Netherlands**

Phone +31 (0) 30 229 25 44  
E-Mail info@sick.nl

**New Zealand**

Phone +64 9 415 0459  
0800 222 278 – tollfree  
E-Mail sales@sick.co.nz

**Norway**

Phone +47 67 81 50 00  
E-Mail sick@sick.no

**Poland**

Phone +48 22 539 41 00  
E-Mail info@sick.pl

**Romania**

Phone +40 356-17 11 20  
E-Mail office@sick.ro

**Russia**

Phone +7 495 283 09 90  
E-Mail info@sick.ru

**Singapore**

Phone +65 6744 3732  
E-Mail sales.gsg@sick.com

**Slovakia**

Phone +421 482 901 201  
E-Mail mail@sick-sk.sk

**Slovenia**

Phone +386 591 78849  
E-Mail office@sick.si

**South Africa**

Phone +27 10 060 0550  
E-Mail info@sickautomation.co.za

**South Korea**

Phone +82 2 786 6321/4  
E-Mail infokorea@sick.com

**Spain**

Phone +34 93 480 31 00  
E-Mail info@sick.es

**Sweden**

Phone +46 10 110 10 00  
E-Mail info@sick.se

**Switzerland**

Phone +41 41 619 29 39  
E-Mail contact@sick.ch

**Taiwan**

Phone +886-2-2375-6288  
E-Mail sales@sick.com.tw

**Thailand**

Phone +66 2 645 0009  
E-Mail marcom.th@sick.com

**Turkey**

Phone +90 (216) 528 50 00  
E-Mail info@sick.com.tr

**United Arab Emirates**

Phone +971 (0) 4 88 65 878  
E-Mail contact@sick.ae

**United Kingdom**

Phone +44 (0)17278 31121  
E-Mail info@sick.co.uk

**USA**

Phone +1 800.325.7425  
E-Mail info@sick.com

**Vietnam**

Phone +65 6744 3732  
E-Mail sales.gsg@sick.com

Detailed addresses and further locations at [www.sick.com](http://www.sick.com)