

# Safe Material Flow

## Access protection for automated material flow

Intelligent safety solutions are the key factor for continuous material flow while protecting people. But the options for safe human-material differentiation are many – it is not always easy to find the right solution on the market for your requirements. SICK offers you support with this consulting assistant.

[Click here to access the question-based consulting assistant.](#)

[Click here to go directly to the overview of solutions.](#)

CREATING  
SAFE  
PRODUCTIVITY

Question

**1**

## What types of objects are transported and how?

### **Small objects on stationary conveyor systems**

(e.g. bottles, candy bars, small workpieces, shoe boxes)

### **Medium-sized objects on stationary conveyor systems**

(e.g. large postal packages, crates, vehicle batteries)

### **Large objects on stationary conveyor systems**

(e.g. white goods, steel rolls, vehicle bodies)

### **Various objects on mobile conveyor systems**

(e.g. objects on automated guided vehicles (AGVs))

### **Various objects via manual transport**

(e.g. manual loading and unloading points)

## Safety solutions for the transport of small objects

[Solution overview](#)

For the automated transport of small, loose objects such as bottles, candy bars, workpieces, etc. on stationary conveyor systems, use of a physical tunnel is recommended as a simple and effective solution for access protection.

### Physical tunnel

Physical separation between people and hazardous areas

## Safety solutions for the transport of small objects

### Physical tunnel

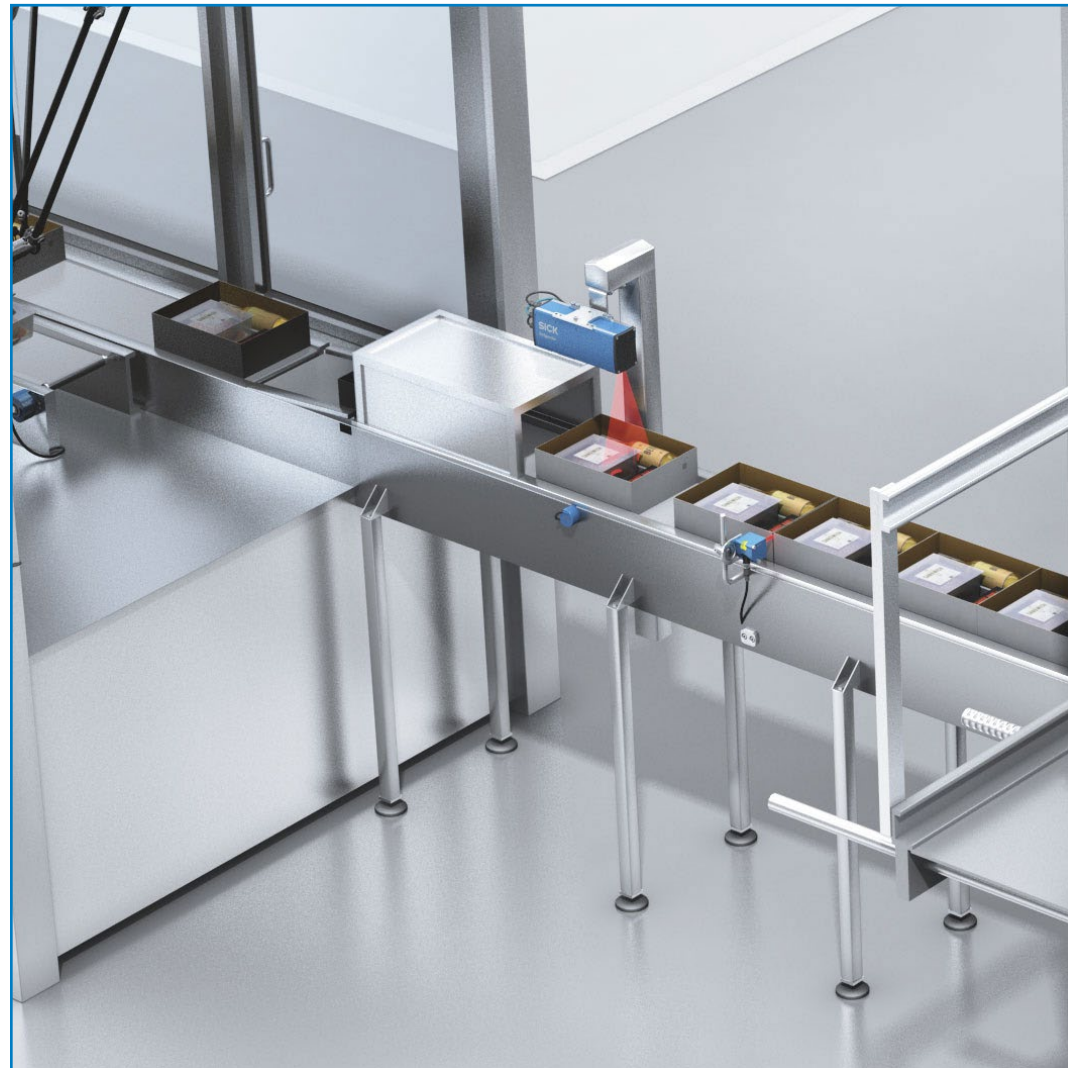

#### Physical tunnel

As a physical guard, the tunnel provides the physical separation between people and hazardous areas.

#### Advantages:

- Can be implemented with different material contours and gaps in the transported material
- Can be used problem-free even in challenging ambient conditions, e.g. outdoors

#### Limitations:

- Large space requirement, as larger safety distances are required
- Limited adaptability if objects change, as it is a rigid physical element
- Not suitable for transporting larger objects

Question

**2**

## What is the shape of the object?

**Objects with  
rectangular contour**

(e.g. postal packages,  
packaged goods)

**Objects with  
irregular shape**

(e.g. vehicle battery on  
a carrier)

## Safety solutions for the transport of medium-sized rectangular objects

[Solution overview](#)

For the transport of medium-sized, uniformly shaped objects (e.g., larger parcels) using stationary conveyor systems, use of the following safety solutions for safe human-material differentiation is recommended.

### Classic muting

Temporary bypassing of the protective device with muting sensors

### Safe Entry Exit

Temporary bypassing of the protective device with the aid of process signals

### deTec4 Smart Box Detection

Intelligent pattern recognition of objects with rectangular contour

## Safety solutions for the transport of medium-sized rectangular objects

### Classic muting

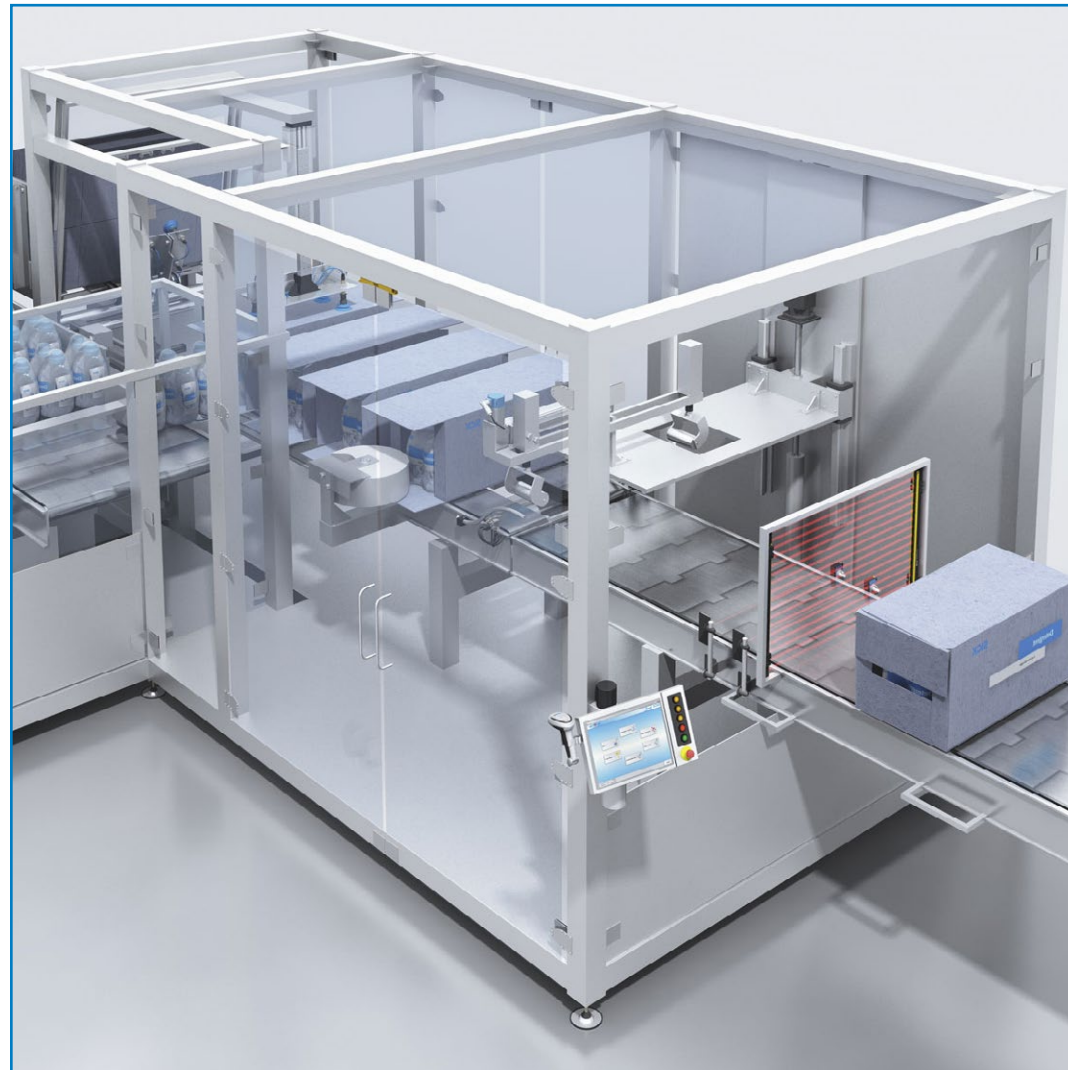

#### Classic muting

Muting sensors initiate a temporary bypass of the protective device when certain muting conditions are met.

#### Advantages:

- Can be implemented flexibly with different material contours and sizes
- Proven safety concept with low complexity
- Different muting setups (L, T and cross muting) can be used

#### Limitations:

- Protective device is briefly bypassed (residual risk)
- Increased space requirements and greater mounting, alignment and maintenance effort due to muting sensors
- Depending on the muting variant, certain requirements for minimum object size and maximum gaps in the object must be observed

#### Safety solutions from SICK:

deTec safety light curtain

deTem safety light-beam sensor

M4000 Advanced safety light-beam sensor

## Safety solutions for the transport of medium-sized rectangular objects



### Safe Entry Exit

#### Safe Entry Exit

Process information is used in the safety logic as a signal to bypass the protective device, thus replacing muting sensors as signal generators.

#### Advantages:

- By eliminating muting sensors, you save space and reduce potential sources of error
- Can be implemented flexibly with different material contours and sizes
- TÜV-certified safety system saves you time and money

#### Limitations:

- Manipulation-proof process signal is required
- Protective device is briefly bypassed (residual risk)



## Safety solutions for the transport of medium-sized rectangular objects

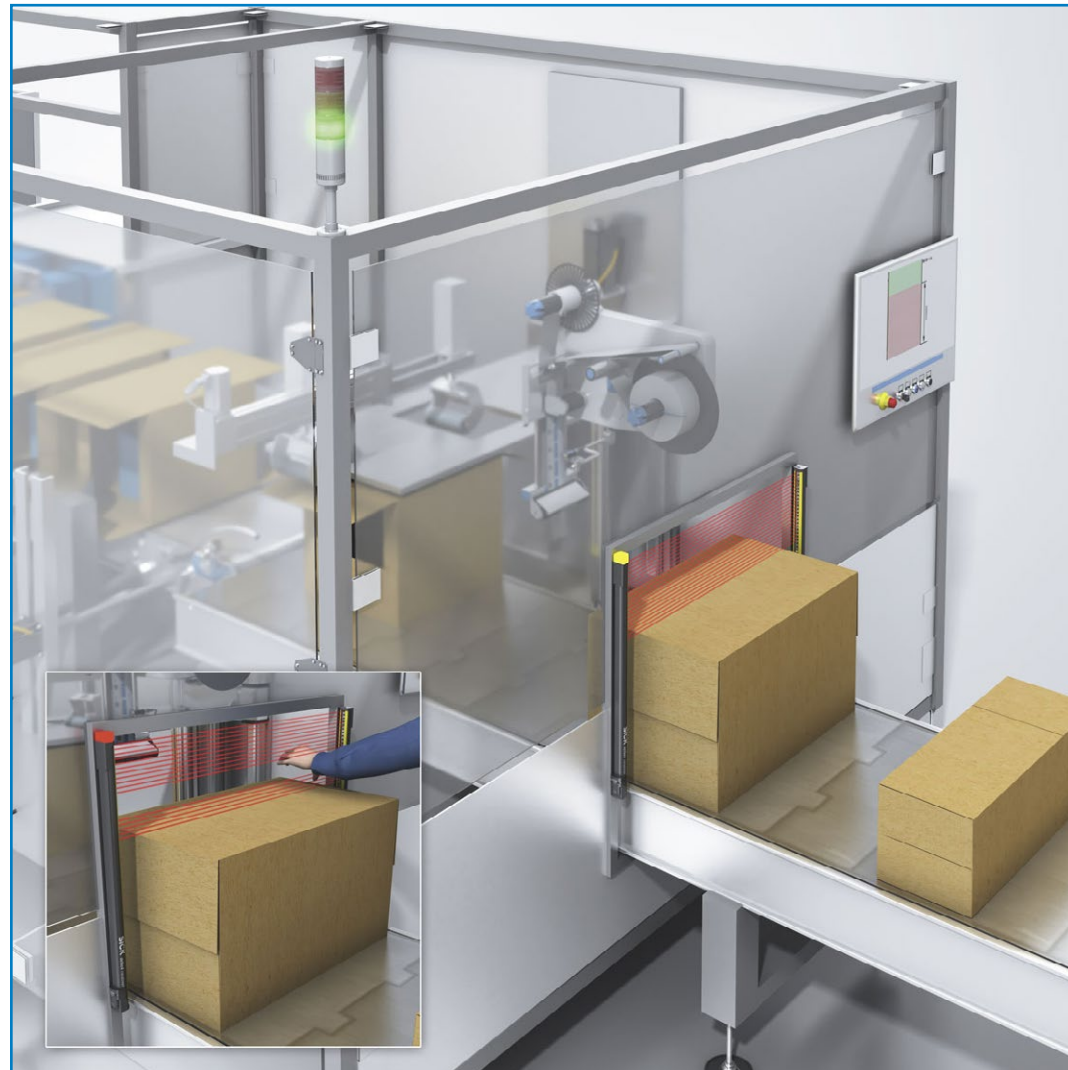

### deTec4 Smart Box Detection

The intelligent pattern recognition function of the deTec4 safety light curtain differentiates people from objects with rectangular contours.

#### Advantages:

- Compared to classic muting solutions and physical tunnels, you save space and reduce the amount of maintenance effort
- Safety light curtain remains active during passage above the object and provides increased safety
- Different box sizes on the conveyor system are automatically detected without any configuration work

#### Limitations:

- Is only suitable for detecting objects with geometrically uniform contours (e.g. rectangles)
- An object height of at least 134 mm is required
- Is not suitable for gaps in the object or stacked boxes

deTec4 Smart Box Detection

## Safety solutions for the transport of medium-sized, irregularly shaped objects

[Solution overview](#)

For the transport of medium-sized, irregularly shaped objects on stationary conveyor systems, use of the following safety solutions for safe human-material differentiation is recommended.

### Classic muting

Temporary bypassing of the protective device with muting sensors

### Safe Entry Exit

Temporary bypassing of the protective device with the aid of process signals

## Safety solutions for the transport of medium-sized, irregularly shaped objects

### Classic muting

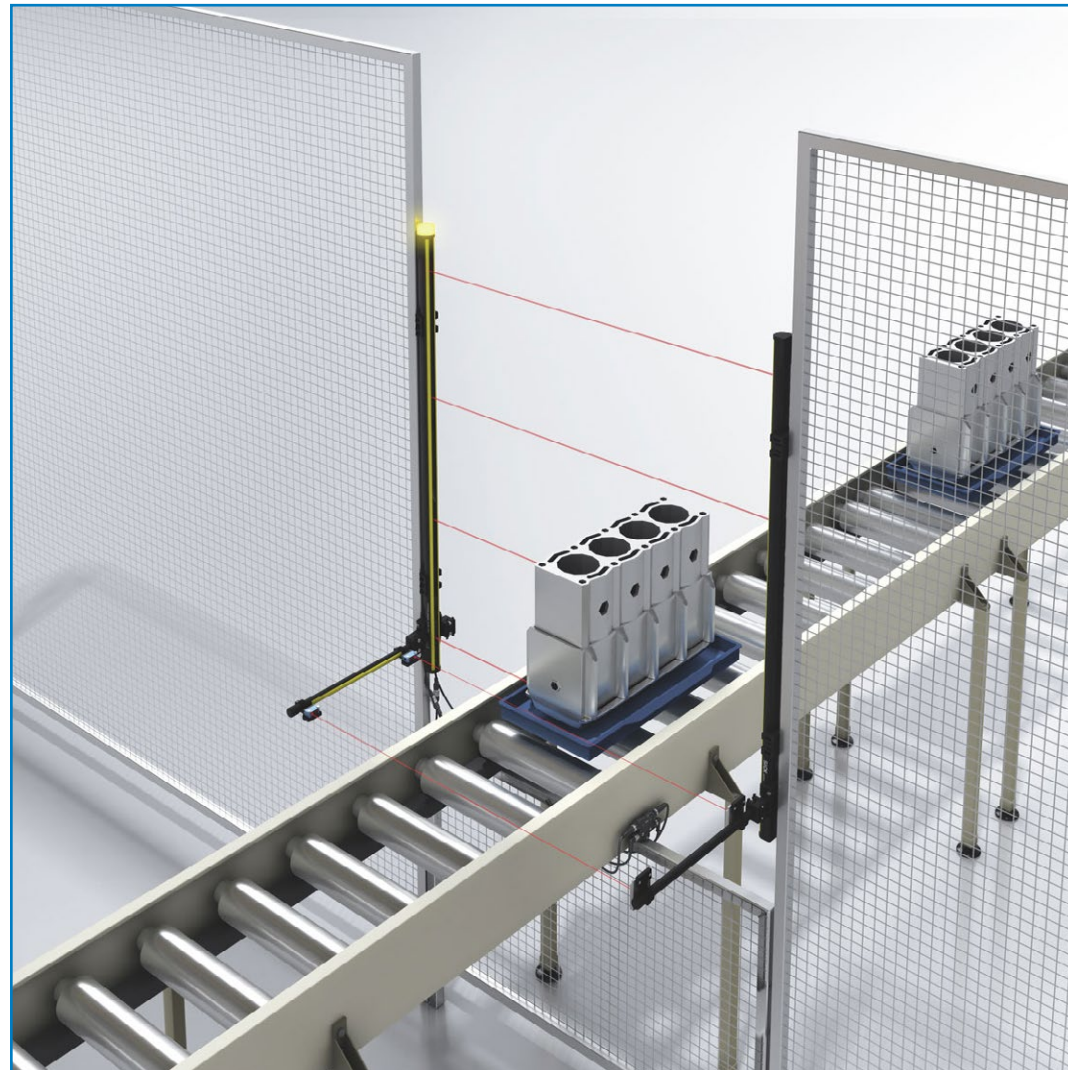

#### Classic muting

Muting sensors initiate a temporary bypass of the protective device when certain muting conditions are met.

#### Advantages:

- Can be implemented flexibly with different material contours and sizes
- Proven safety concept with low complexity
- Different muting setups (L, T and cross muting) can be used

#### Limitations:

- Protective device is briefly bypassed (residual risk)
- Increased space requirements and greater mounting, alignment and maintenance effort due to muting sensors
- Depending on the muting variant, certain requirements for minimum object size and maximum gaps in the object must be observed

#### Safety solutions from SICK:

deTec safety light curtain

deTem safety light-beam sensor

M4000 Advanced safety light-beam sensor

## Safety solutions for the transport of medium-sized, irregularly shaped objects



### Safe Entry Exit

#### Safe Entry Exit

Process information is used in the safety logic as a signal to bypass the protective device, thus replacing muting sensors as signal generators.

#### Advantages:

- By eliminating muting sensors, you save space and reduce potential sources of error
- Can be implemented flexibly with different material contours and sizes
- TÜV-certified safety system saves you time and money

#### Limitations:

- Manipulation-proof process signal is required
- Protective device is briefly bypassed (residual risk)

Question

**2**

**What type of conveyor system is used?**

**Pallet conveyor system**

**Skid conveyor system**

**Other conveyor system**

(e.g. belt, chain, conveyor,  
hanging conveyor)

## Safety solutions for pallet conveyor systems

[Solution overview](#)

For the transport of goods on pallet conveyor systems, use of the following safety solutions for safe human-material differentiation is recommended.

### Classic muting

Temporary bypassing of the protective device with muting sensors

### Safe Entry Exit

Temporary bypassing of the protective device with the aid of process signals

### deTem4 LT Muting A/P

Muting solution with pre-installed and already aligned muting sensors

## Safety solutions for pallet conveyor systems

### Classic muting



#### Classic muting

Muting sensors initiate a temporary bypass of the protective device when certain muting conditions are met.

#### Advantages:

- Can be implemented flexibly with different material contours and sizes
- Proven safety concept with low complexity
- Different muting setups (L, T and cross muting) can be used

#### Limitations:

- Protective device is briefly bypassed (residual risk)
- Increased space requirements and greater mounting, alignment and maintenance effort due to muting sensors
- Depending on the muting variant, certain requirements for minimum object size and maximum gaps in the object must be observed

#### Safety solutions from SICK:

deTec safety light curtain

deTem safety light-beam sensor

M4000 Advanced safety light-beam sensor

## Safety solutions for pallet conveyor systems



### Safe Entry Exit

#### Safe Entry Exit

Process information is used in the safety logic as a signal to bypass the protective device, thus replacing muting sensors as signal generators.

#### Advantages:

- By eliminating muting sensors, you save space and reduce potential sources of error
- Can be implemented flexibly with different material contours and sizes
- TÜV-certified safety system saves you time and money

#### Limitations:

- Manipulation-proof process signal is required
- Protective device is briefly bypassed (residual risk)



## Safety solutions for pallet conveyor systems

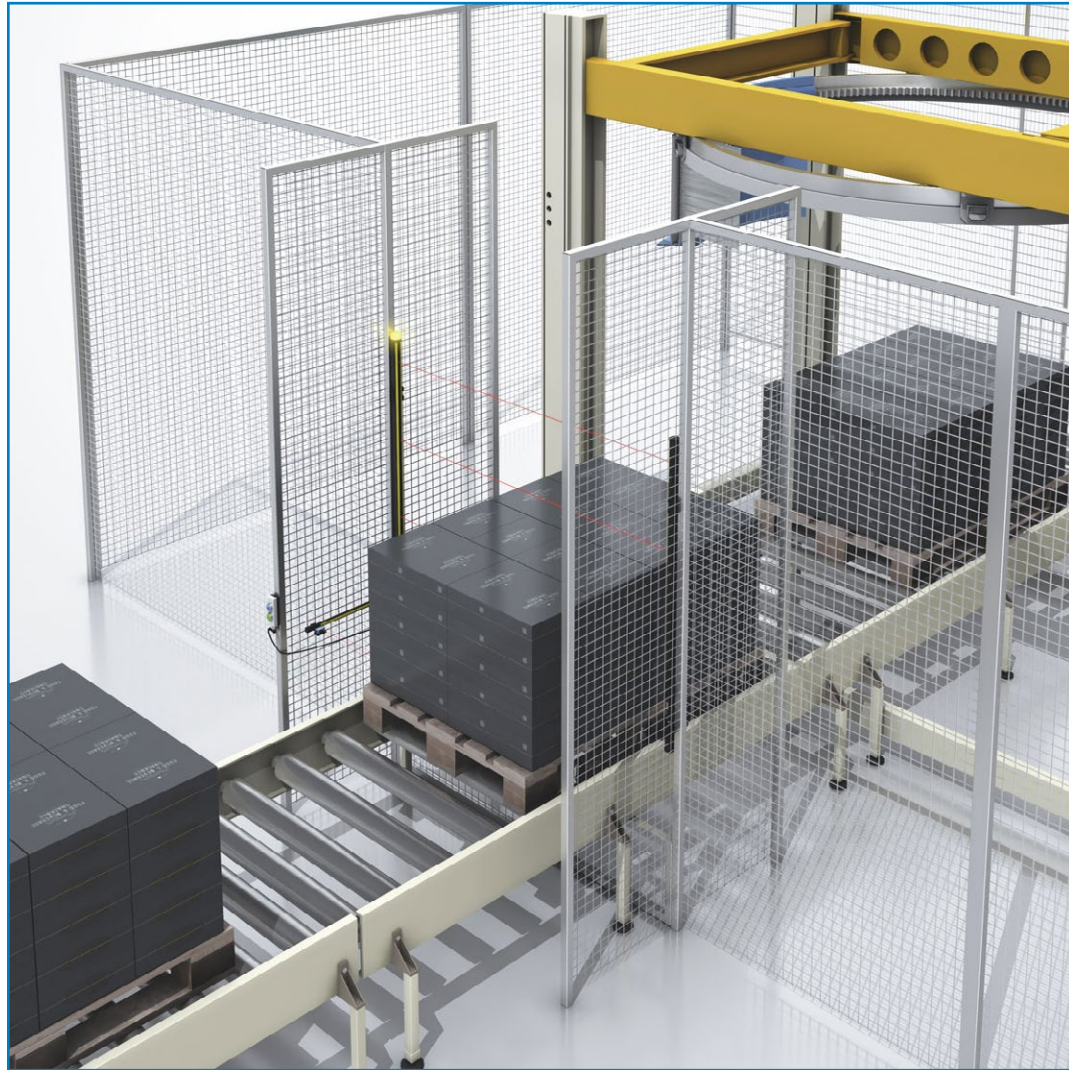

### deTem4 LT Muting A/P

Safety multibeam sensor with pre-installed and already aligned muting sensors (plug and play).

#### Advantages:

- You receive a complete muting set and save time when ordering
- Easy to wire and seamless integration, as the connection is only made on one active side
- Economical solution, especially for pallet conveyor systems

#### Limitations:

- Standardized muting parameters cannot be changed and space-saving cross muting is not possible
- Protective device is briefly bypassed (residual risk)
- Requirements regarding minimum object size and maximum gaps in the object must be observed

deTem4 LT Muting A/P

## Safety solutions for skid conveyor systems

[Solution overview](#)

For the transport of goods on skid conveyor systems, use of the following safety solutions for safe human-material differentiation is recommended.

### Classic muting

Temporary bypassing of the protective device with muting sensors

### Safe Portal

Adaptive protective field evaluation of safety laser scanners through contour detection

### C4000 Fusion

Reliable human-material differentiation through pattern recognition

## Safety solutions for skid conveyor systems

### Classic muting

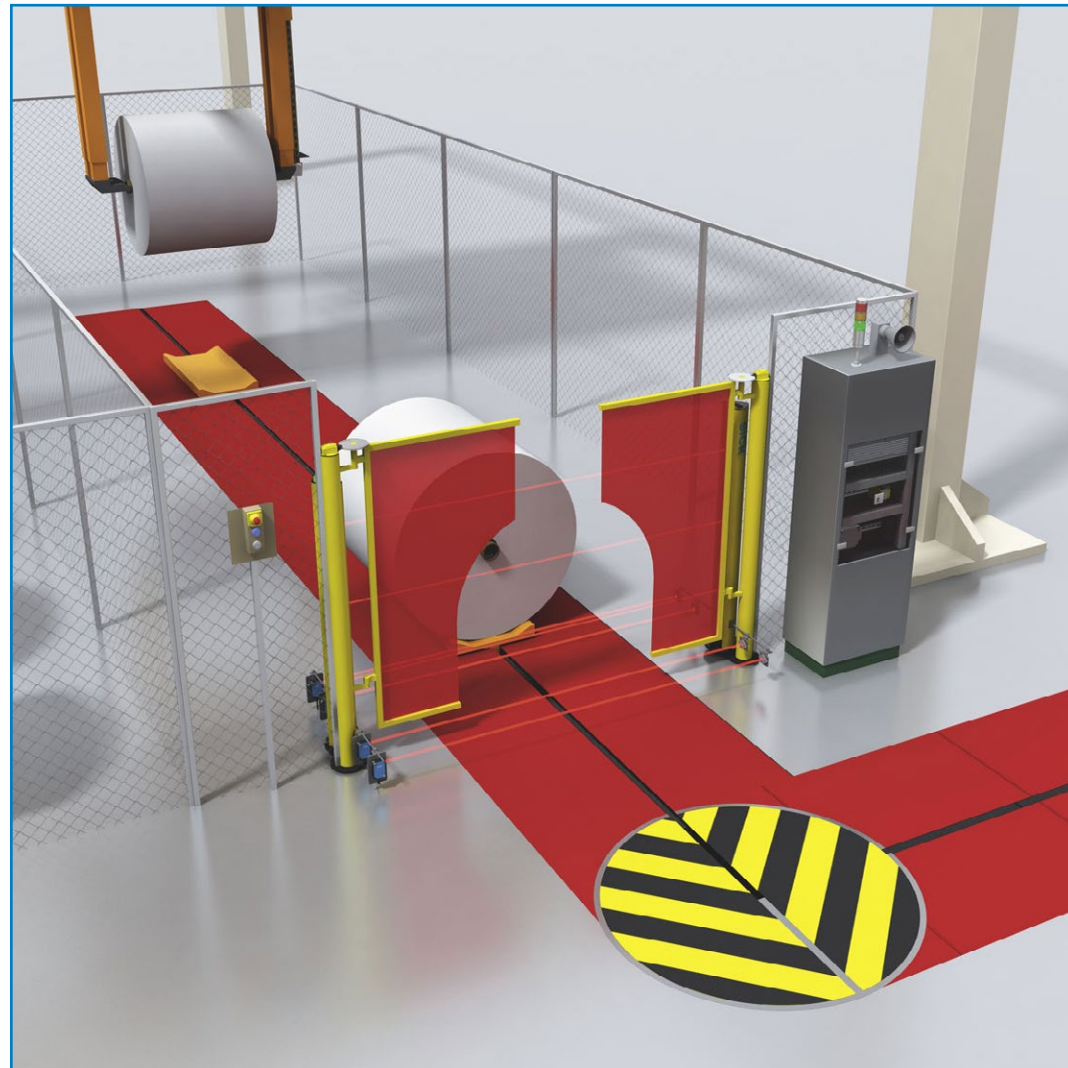

### Classic muting

Muting sensors initiate a temporary bypass of the protective device when certain muting conditions are met.

#### Advantages:

- Can be implemented flexibly with different material contours and sizes
- Proven safety concept with low complexity
- Different muting setups (L, T and cross muting) can be used

#### Limitations:

- Protective device is briefly bypassed (residual risk)
- Increased space requirements and greater mounting, alignment and maintenance effort due to muting sensors
- Depending on the muting variant, certain requirements for minimum object size and maximum gaps in the object must be observed

#### Safety solutions from SICK:

deTec safety light curtain

deTem safety light-beam sensor

M4000 Advanced safety light-beam sensor

## Safety solutions for skid conveyor systems

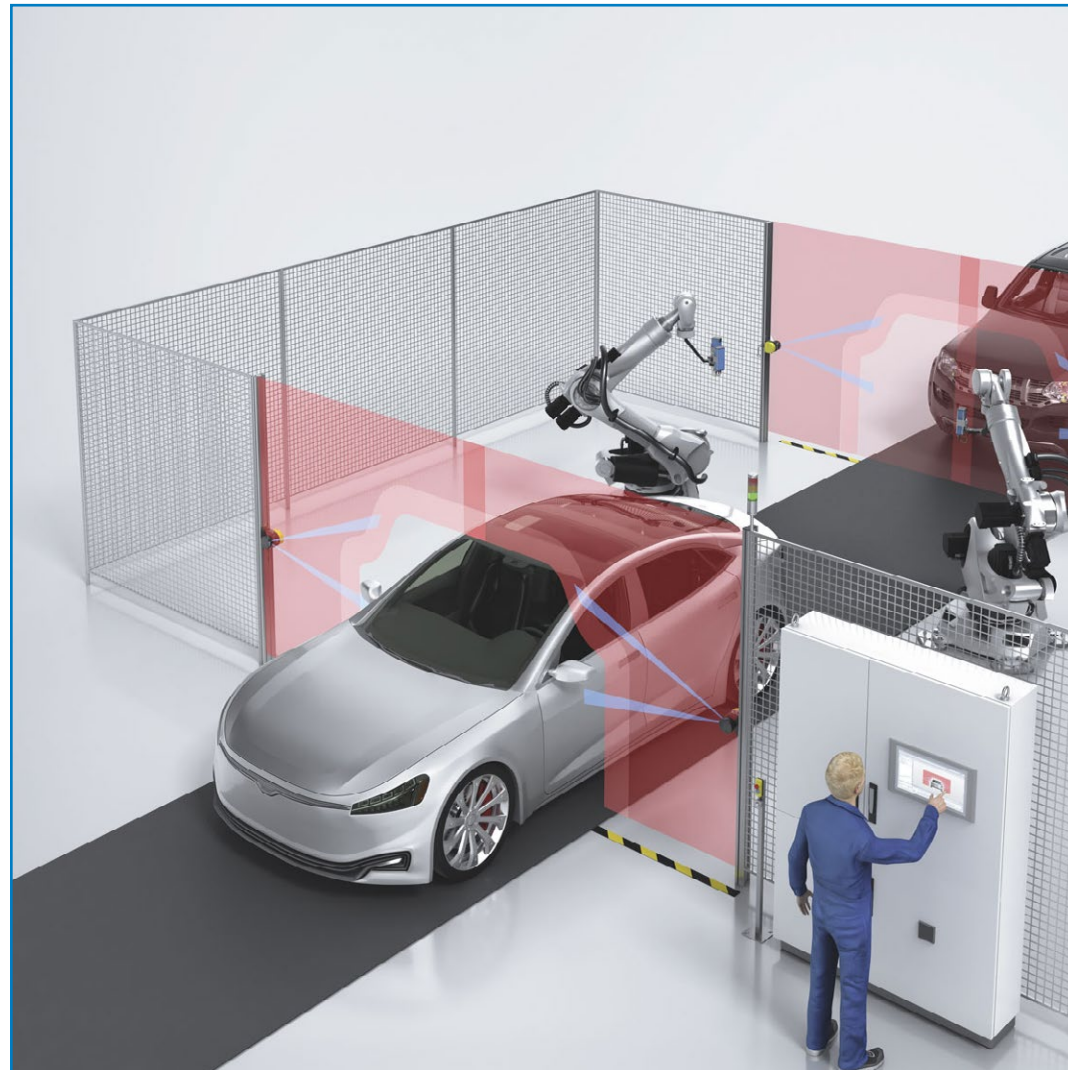

### Safe Portal

#### Safe Portal

Two safety laser scanners detect the material based on pre-defined contours. A function block monitors the status of the adaptive protective fields.

#### Advantages:

- Multiple adaptive protective fields that can be flexibly adapted to the material contour (ideal for different vehicle types on one line, for example)
- By eliminating muting sensors and swinging doors, you save space and reduce the amount of maintenance effort
- The permanent protective field monitoring detects persons on and next to the object

#### Limitations:

- Is not suitable for gaps in the transported material
- More complex implementation, as logic integration into existing controller is necessary

## Safety solutions for skid conveyor systems

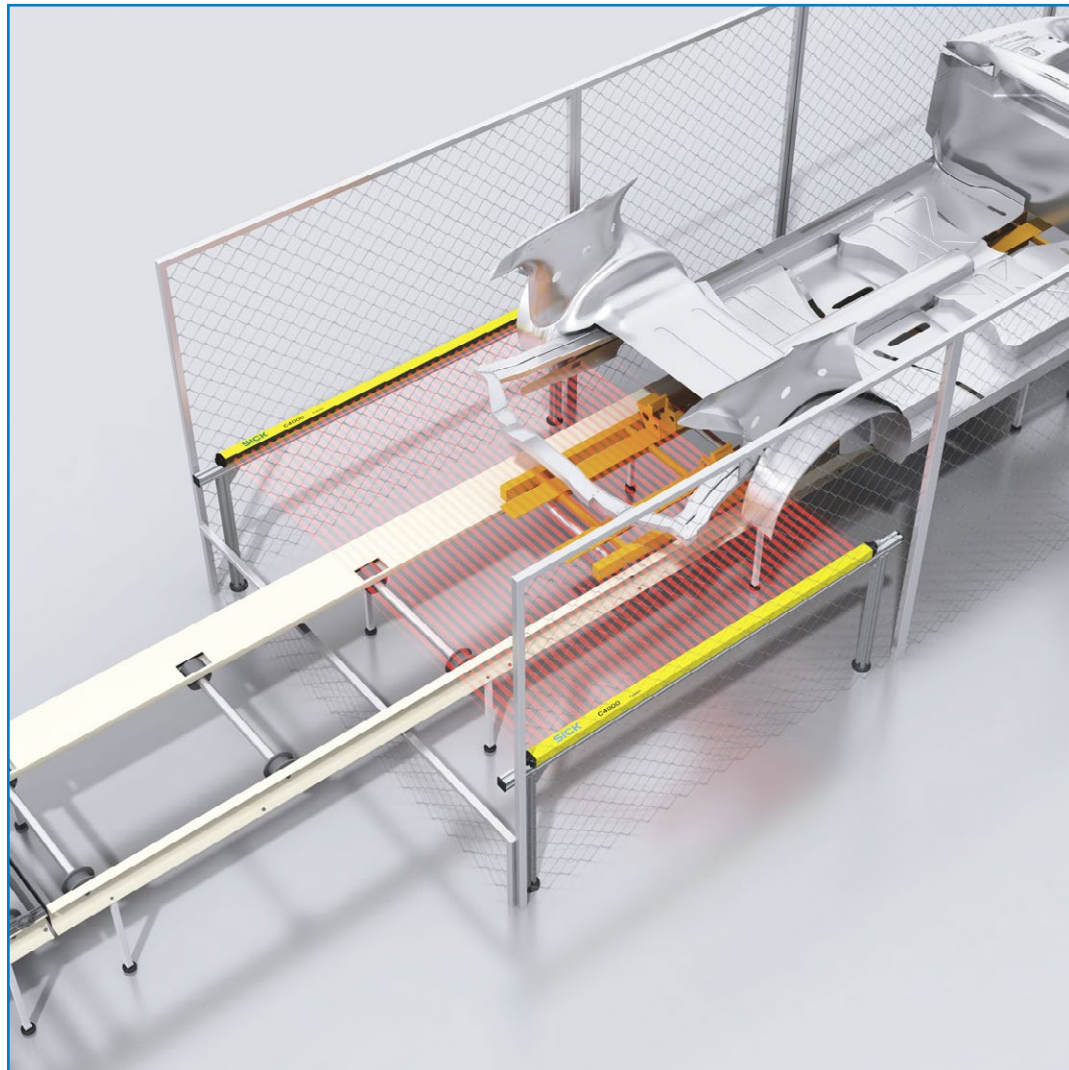

### C4000 Fusion

The C4000 Fusion is mounted horizontally. The skid structure is recognized by its pattern and thus reliably distinguished from persons.

#### Advantages:

- Different skid structures can be taught in via the configuration software
- By eliminating muting sensors and swinging doors, you reduce the amount of effort for implementation and maintenance
- The protective device remains active at all times

#### Limitations:

- Large space requirement due to horizontal installation and required safety distance
- Residual risk, as persons on the transported material are not detected
- Large amount of conversion work when the contours and sizes of the transported material change

C4000 Fusion

## Safety solutions for other conveyor systems

[Solution overview](#)

For the transport of large objects on conveyors or chain, belt or hanging conveyor systems, etc., use of the following safety solutions for safe human-material differentiation is recommended.

### Classic muting

Temporary bypassing of the protective device with muting sensors

### Safe Entry Exit

Temporary bypassing of the protective device with the aid of process signals

### Safe Portal

Adaptive protective field evaluation of safety laser scanners through contour detection

### deTec4 Smart Box Detection

Intelligent pattern recognition of objects with rectangular contour

## Safety solutions for other conveyor systems

### Classic muting



#### Classic muting

Muting sensors initiate a temporary bypass of the protective device when certain muting conditions are met.

#### Advantages:

- Can be implemented flexibly with different material contours and sizes
- Proven safety concept with low complexity
- Different muting setups (L, T and cross muting) can be used

#### Limitations:

- Protective device is briefly bypassed (residual risk)
- Increased space requirements and greater mounting, alignment and maintenance effort due to muting sensors
- Depending on the muting variant, certain requirements for minimum object size and maximum gaps in the object must be observed

#### Safety solutions from SICK:

deTec safety light curtain

deTem safety light-beam sensor

M4000 Advanced safety light-beam sensor

## Safety solutions for other conveyor systems



### Safe Entry Exit

#### Safe Entry Exit

Process information is used in the safety logic as a signal to bypass the protective device, thus replacing muting sensors as signal generators.

#### Advantages:

- By eliminating muting sensors, you save space and reduce potential sources of error
- Can be implemented flexibly with different material contours and sizes
- TÜV-certified safety system saves you time and money

#### Limitations:

- Manipulation-proof process signal is required
- Protective device is briefly bypassed (residual risk)



## Safety solutions for other conveyor systems

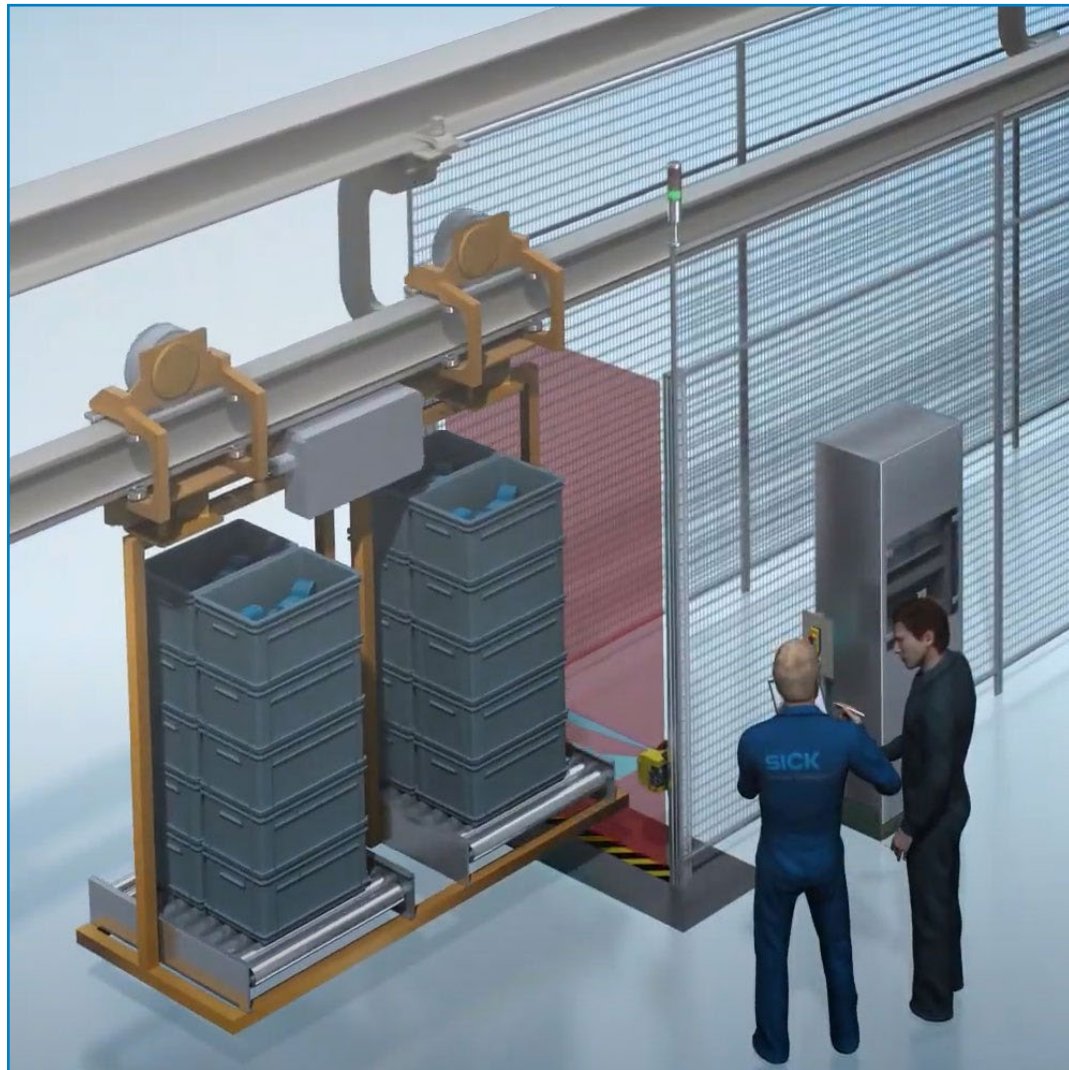

### Safe Portal

Two safety laser scanners detect the material based on pre-defined contours. A function block monitors the status of the adaptive protective fields.

#### Advantages:

- Multiple adaptive protective fields that can be flexibly adapted to the material contour (ideal for different vehicle types on one line, for example)
- By eliminating muting sensors and swinging doors, you save space and reduce the amount of maintenance effort
- The permanent protective field monitoring detects persons on and next to the object

#### Limitations:

- Is not suitable for gaps in the transported material
- More complex implementation, as logic integration into existing controller is necessary

Safe Portal

## Safety solutions for other conveyor systems

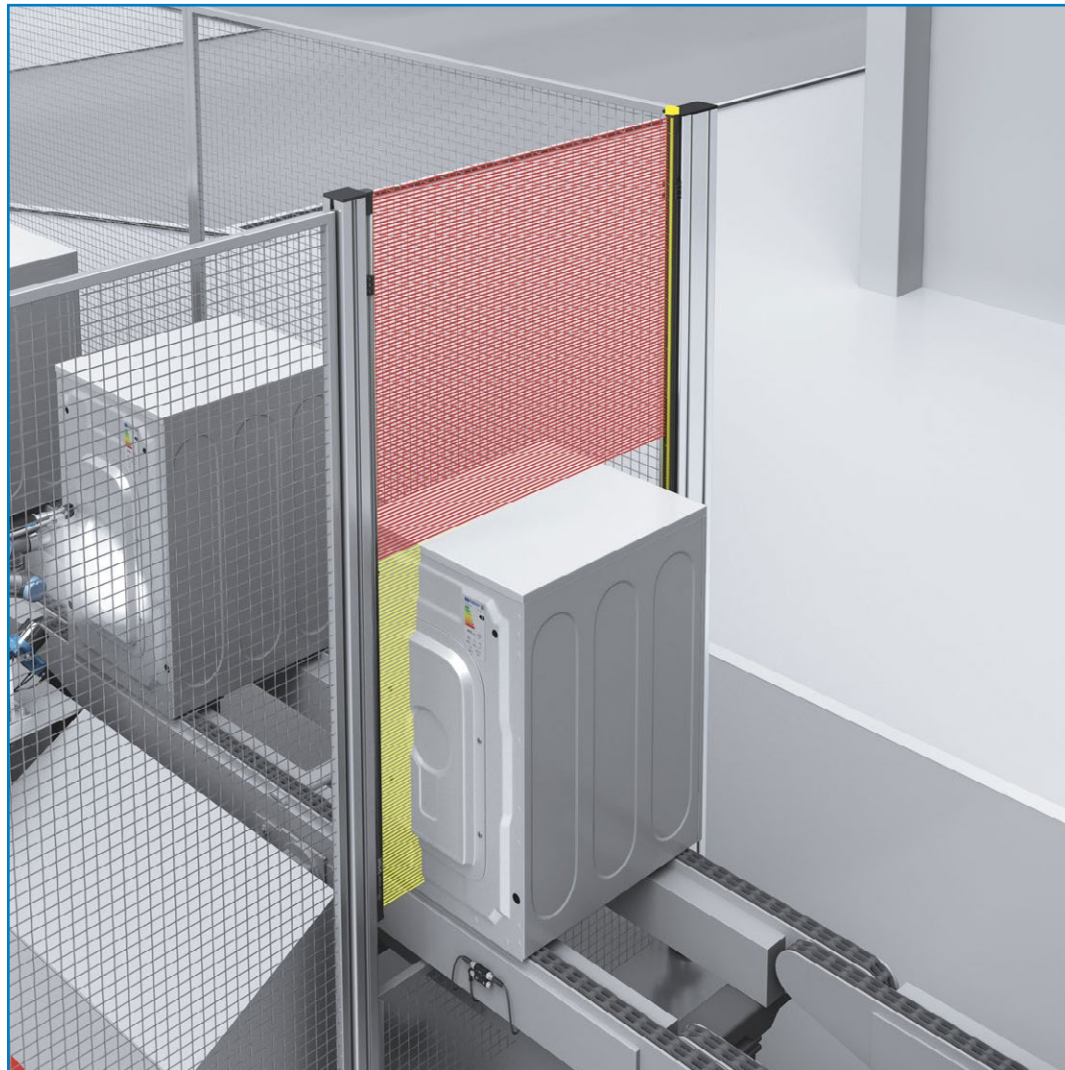

### deTec4 Smart Box Detection

The intelligent pattern recognition function of the deTec4 safety light curtain differentiates people from objects with rectangular contours.

#### Advantages:

- Compared to classic muting solutions and physical tunnels, you save space and reduce the amount of maintenance effort
- Safety light curtain remains active during passage above the object and provides increased safety
- Different box sizes on the conveyor system are automatically detected without any configuration work

#### Limitations:

- Is only suitable for detecting objects with geometrically uniform contours (e.g. rectangles)
- An object height of at least 134 mm is required
- Is not suitable for gaps in the object or stacked boxes

deTec4 Smart Box Detection

## Safety solutions for the transport of objects on mobile conveyor systems

[Solution overview](#)

For the transport of objects on mobile conveyor systems (AGVs, AMRs, etc.), use of the following safety solutions for safe human-material differentiation is recommended.

### Classic muting

Temporary bypassing of the protective device with muting sensors

### Safe Portal

Adaptive protective field evaluation of safety laser scanners through contour detection

### Safe Entry Exit

Temporary bypassing of the protective device with the aid of process signals

## Safety solutions for the transport of objects on mobile conveyor systems

### Classic muting

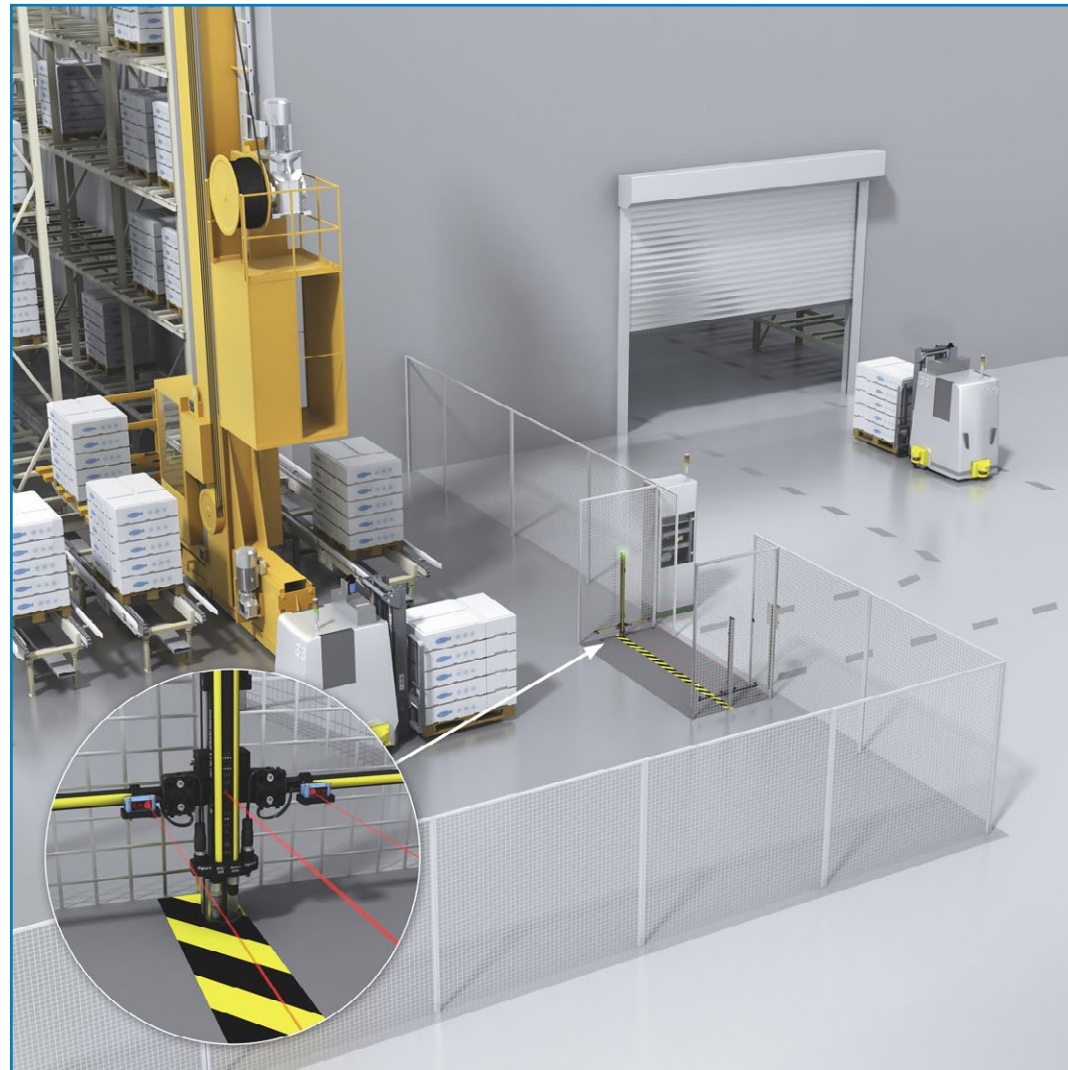

#### Classic muting

Muting sensors initiate a temporary bypass of the protective device when certain muting conditions are met.

#### Advantages:

- Can be implemented flexibly with different material contours and sizes
- Proven safety concept with low complexity
- Different muting setups (L, T and cross muting) can be used

#### Limitations:

- Protective device is briefly bypassed (residual risk)
- Increased space requirements and greater mounting, alignment and maintenance effort due to muting sensors
- Depending on the muting variant, certain requirements for minimum object size and maximum gaps in the object must be observed

#### Safety solutions from SICK:

deTec safety light curtain

deTem safety light-beam sensor

M4000 Advanced safety light-beam sensor

## Safety solutions for the transport of objects on mobile conveyor systems



### Safe Portal

#### Safe Portal

Two safety laser scanners detect the material based on pre-defined contours. A function block monitors the status of the adaptive protective fields.

#### Advantages:

- Multiple adaptive protective fields that can be flexibly adapted to the material contour (ideal for different vehicle types on one line, for example)
- By eliminating muting sensors and swinging doors, you save space and reduce the amount of maintenance effort
- The permanent protective field monitoring detects persons on and next to the object

#### Limitations:

- Is not suitable for gaps in the transported material
- More complex implementation, as logic integration into existing controller is necessary

## Safety solutions for the transport of objects on mobile conveyor systems



### Safe Entry Exit

Process information is used in the safety logic as a signal to bypass the protective device, thus replacing muting sensors as signal generators.

#### Advantages:

- By eliminating muting sensors, you save space and reduce potential sources of error
- Can be implemented flexibly with different material contours and sizes
- TÜV-certified safety system saves you time and money

#### Limitations:

- Manipulation-proof process signal is required
- Protective device is briefly bypassed (residual risk)

Safe Entry Exit

## Safety solutions for manual transport of objects

[Solution overview](#)

For manual loading or unloading operations, use of access gate stations is recommended. There are also clever safety solutions such as the Safeguard Detector, which are used for certain types of machines.

### Access gate station

For manual feeding and removal of material, e.g. pallets

### Safeguard Detector

For protecting carton erectors on packaging machines, for example

## Safety solutions for manual transport of objects

### Access gate station



#### Access gate station

Access to the loading and unloading area is protected by at least two opto-electronic protective devices forming an access gate.

#### Advantages:

- Flexible use with different material contours and sizes
- Also suitable for gaps in the transported material
- Easy implementation thanks to low complexity of the application

#### Limitations:

- Manual material transport and manual release (reset) after interruption of the protective device
- Requires a lot of space for the access gate
- The operator is responsible for correct use (risk of manipulation)



## Safety solutions for manual transport of objects

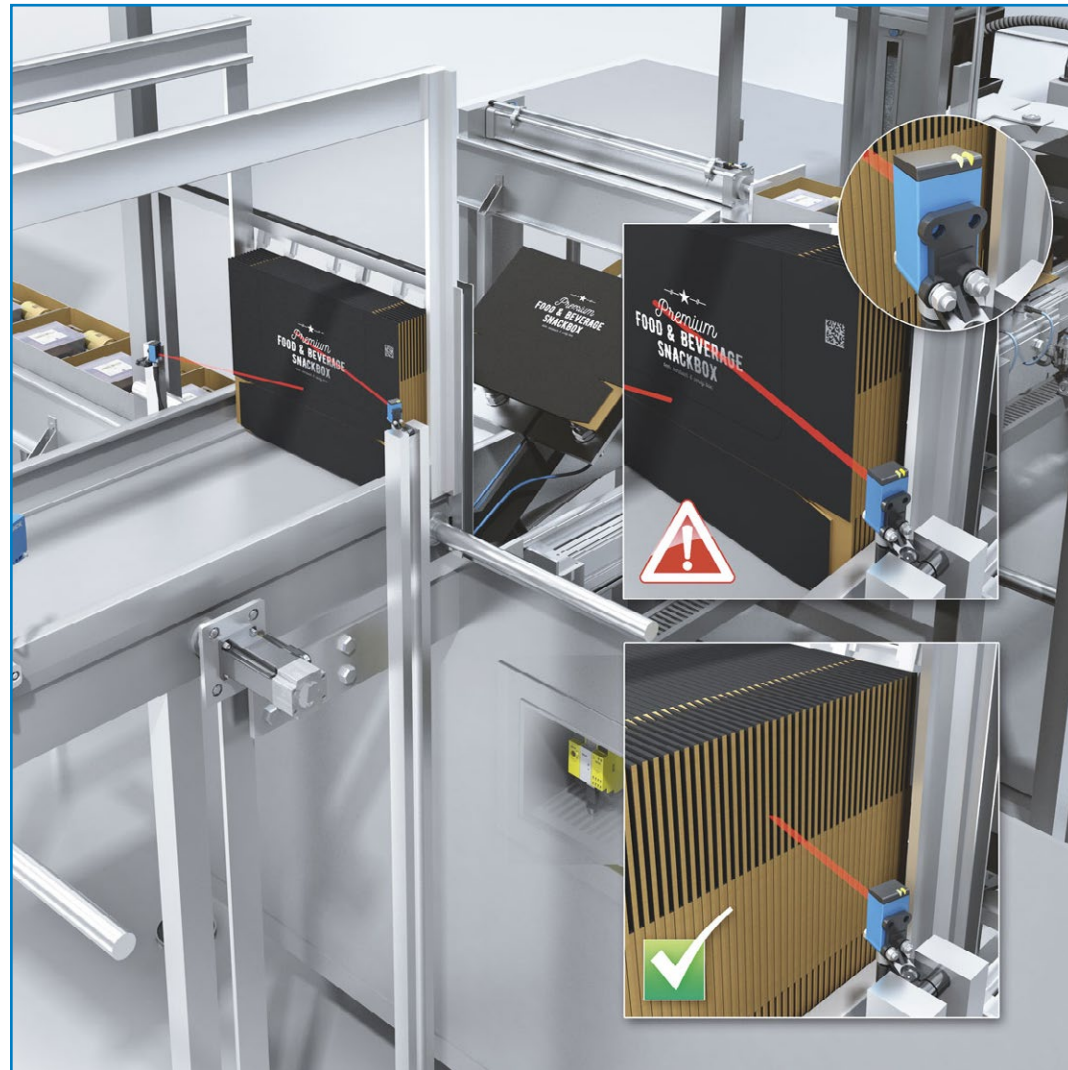

### Safeguard Detector

#### Safeguard Detector

The material itself serves as a natural separation or physical barrier to the hazardous area. Safeguard Detector ensures the safe detection of a sufficient amount of material.

#### Advantages:

- Compared to physical tunnels, you save space and are more flexible, e.g. for carton erectors on packaging machines
- Easy to integrate into existing safety controllers
- The TÜV-certified safety system saves you time and money when documenting and validating the safety application

#### Limitations:

- Limited range of application regarding the detectable material

## Safety solutions for access protection with automated material flow

[Solution overview](#)

## Safety solutions for access protection with automated material flow

### Physical tunnel

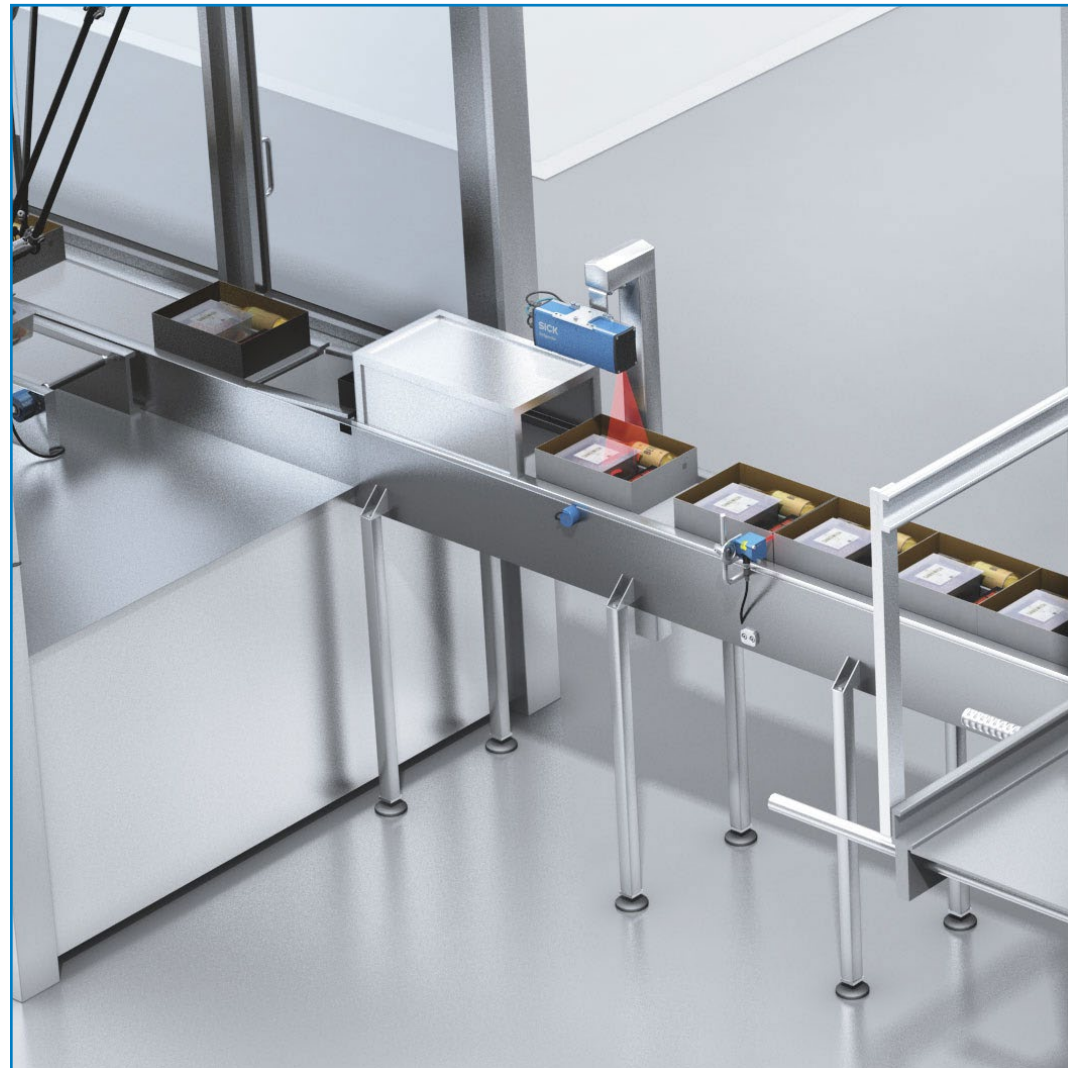

#### Physical tunnel

As a physical guard, the tunnel provides the physical separation between people and hazardous areas.

#### Advantages:

- Can be implemented with different material contours and gaps in the transported material
- Can be used problem-free even in challenging ambient conditions, e.g. outdoors

#### Limitations:

- Large space requirement, as larger safety distances are required
- Limited adaptability if objects change, as it is a rigid physical element
- Not suitable for transporting larger objects

## Safety solutions for access protection with automated material flow

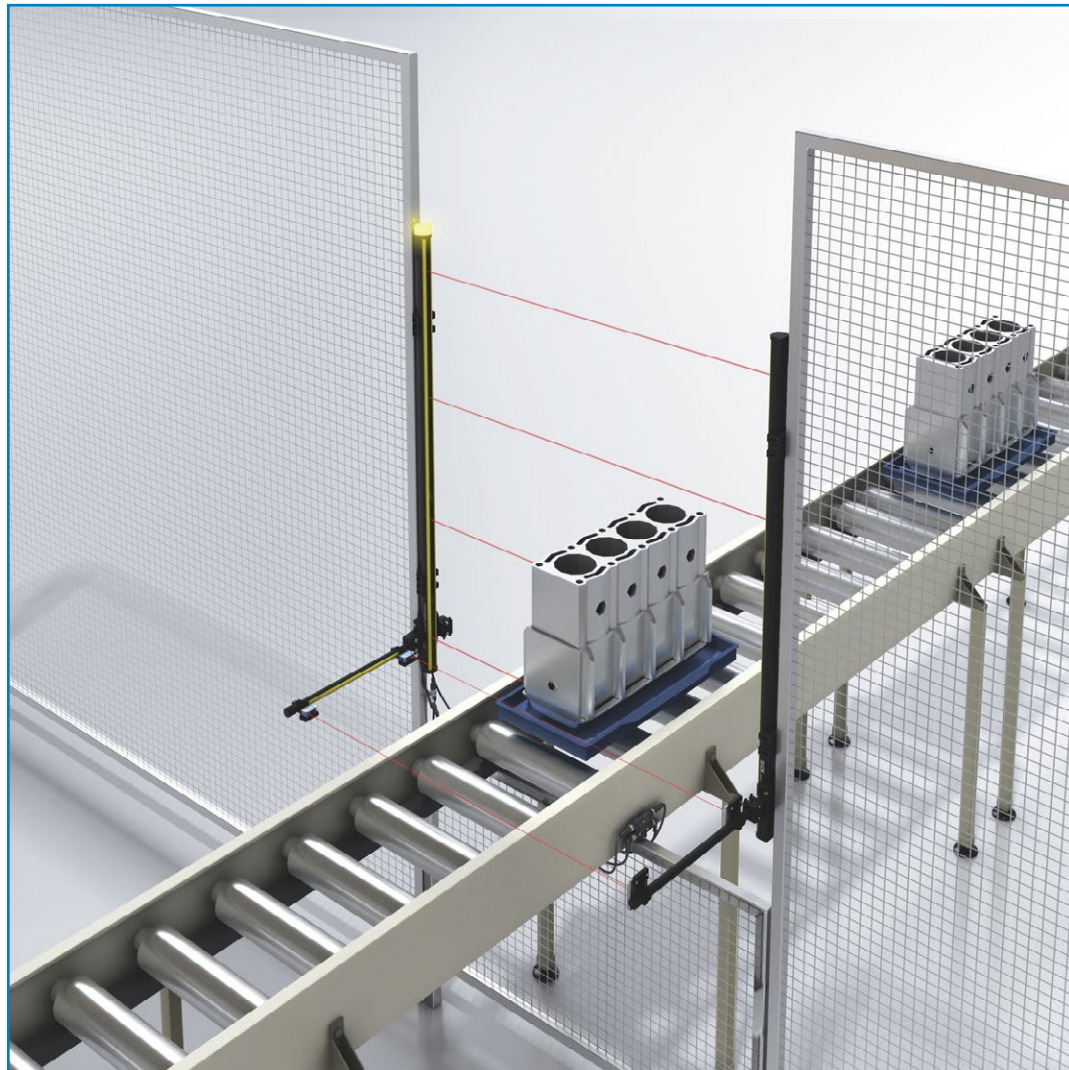

### Classic muting

#### Classic muting

Muting sensors initiate a temporary bypass of the protective device when certain muting conditions are met.

#### Advantages:

- Can be implemented flexibly with different material contours and sizes
- Proven safety concept with low complexity
- Different muting setups (L, T and cross muting) can be used

#### Limitations:

- Protective device is briefly bypassed (residual risk)
- Increased space requirements and greater mounting, alignment and maintenance effort due to muting sensors
- Depending on the muting variant, certain requirements for minimum object size and maximum gaps in the object must be observed

#### Safety solutions from SICK:

deTec safety light curtain

deTem safety light-beam sensor

M4000 Advanced safety light-beam sensor

## Safety solutions for access protection with automated material flow

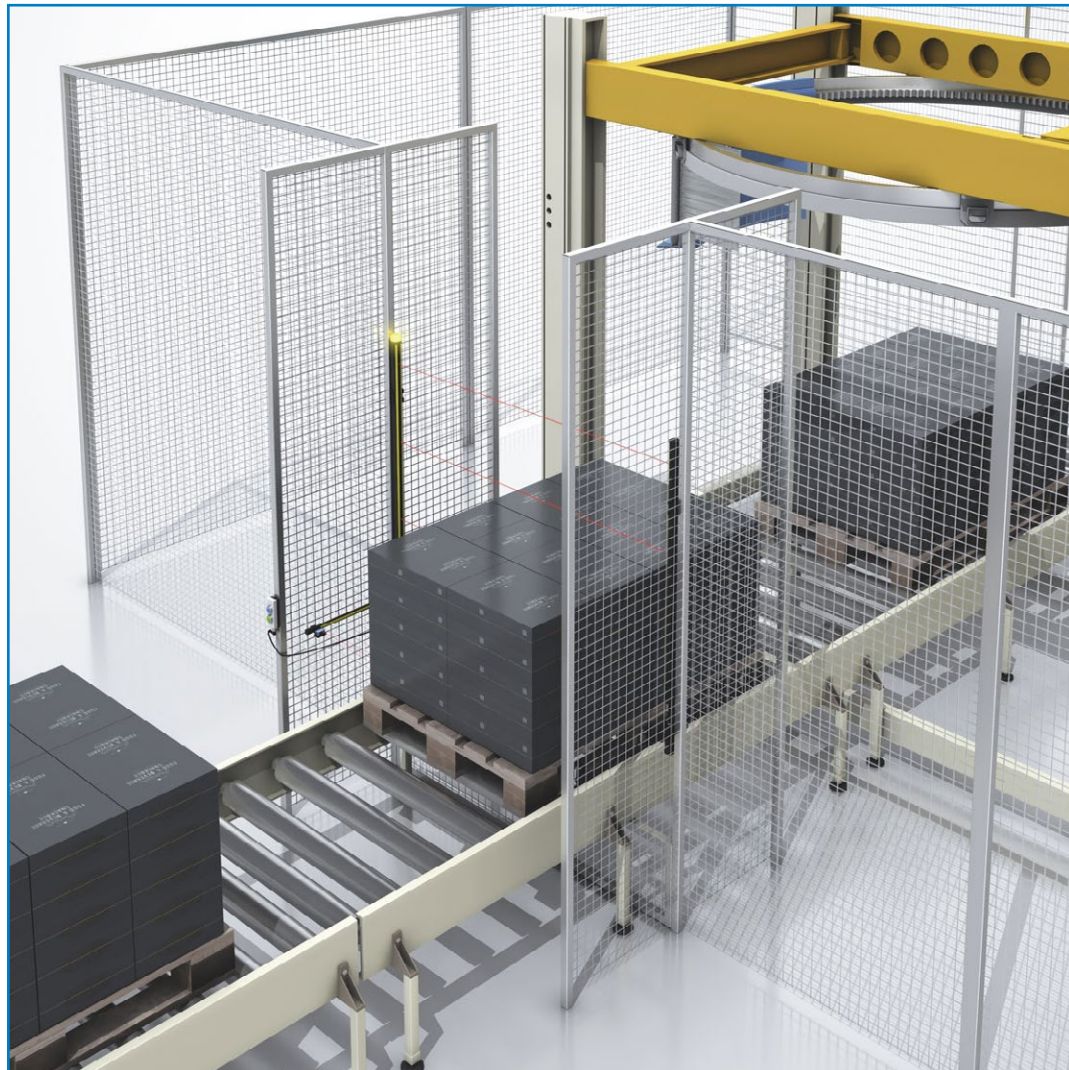

### deTem4 LT Muting A/P

Safety multibeam sensor with pre-installed and already aligned muting sensors (plug and play).

#### Advantages:

- You receive a complete muting set and save time when ordering
- Easy to wire and seamless integration, as the connection is only made on one active side
- Economical solution, especially for pallet conveyor systems

#### Limitations:

- Standardized muting parameters cannot be changed and space-saving cross muting is not possible
- Protective device is briefly bypassed (residual risk)
- Requirements regarding minimum object size and maximum gaps in the object must be observed

deTem4 LT Muting A/P

## Safety solutions for access protection with automated material flow



### Safe Entry Exit

Process information is used in the safety logic as a signal to bypass the protective device, thus replacing muting sensors as signal generators.

#### Advantages:

- By eliminating muting sensors, you save space and reduce potential sources of error
- Can be implemented flexibly with different material contours and sizes
- TÜV-certified safety system saves you time and money

#### Limitations:

- Manipulation-proof process signal is required
- Protective device is briefly bypassed (residual risk)

Safe Entry Exit

## Safety solutions for access protection with automated material flow

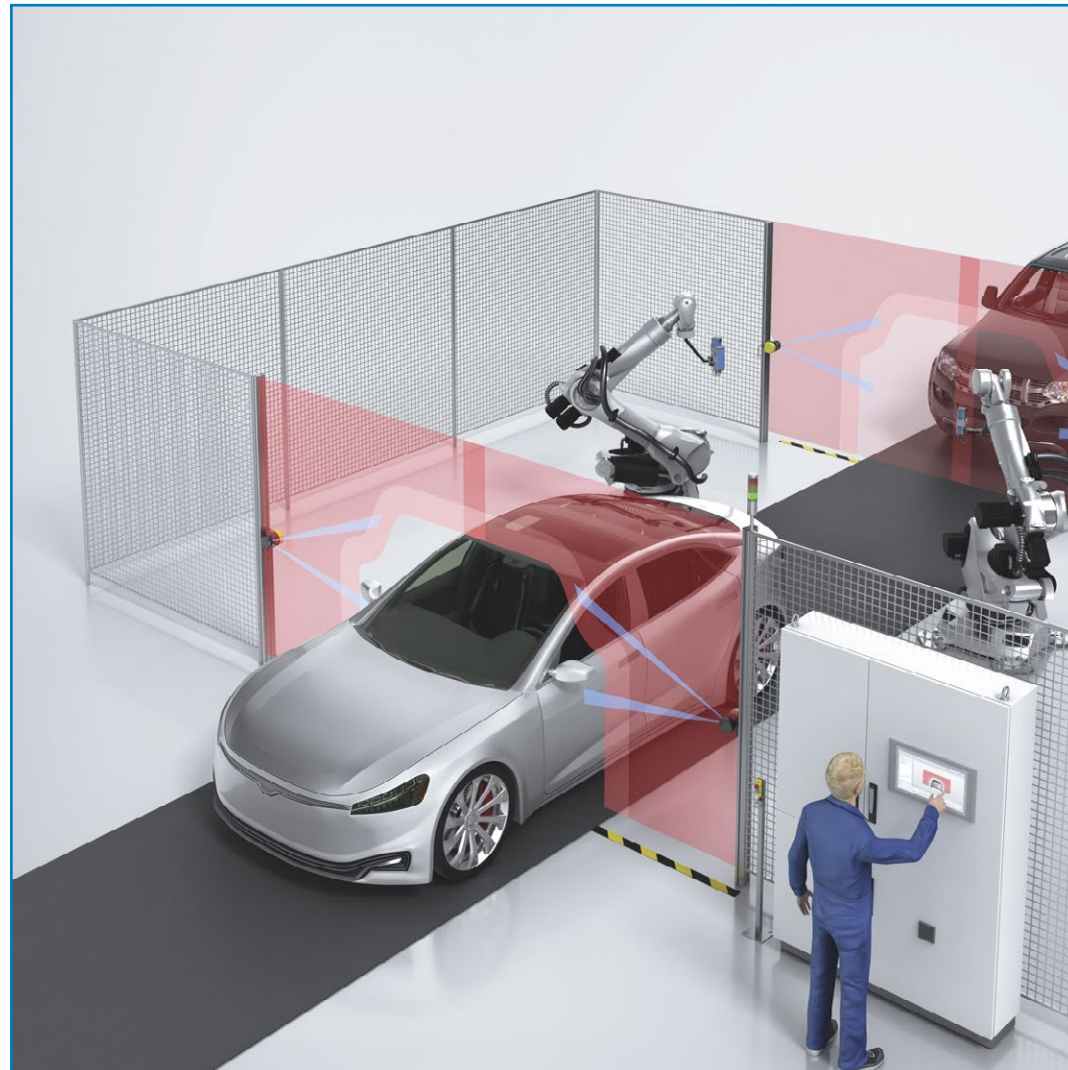

### Safe Portal

Two safety laser scanners detect the material based on pre-defined contours. A function block monitors the status of the adaptive protective fields.

### Advantages:

- Multiple adaptive protective fields that can be flexibly adapted to the material contour (ideal for different vehicle types on one line, for example)
- By eliminating muting sensors and swinging doors, you save space and reduce the amount of maintenance effort
- The permanent protective field monitoring detects persons on and next to the object

### Limitations:

- Is not suitable for gaps in the transported material
- More complex implementation, as logic integration into existing controller is necessary

Safe Portal

## Safety solutions for access protection with automated material flow

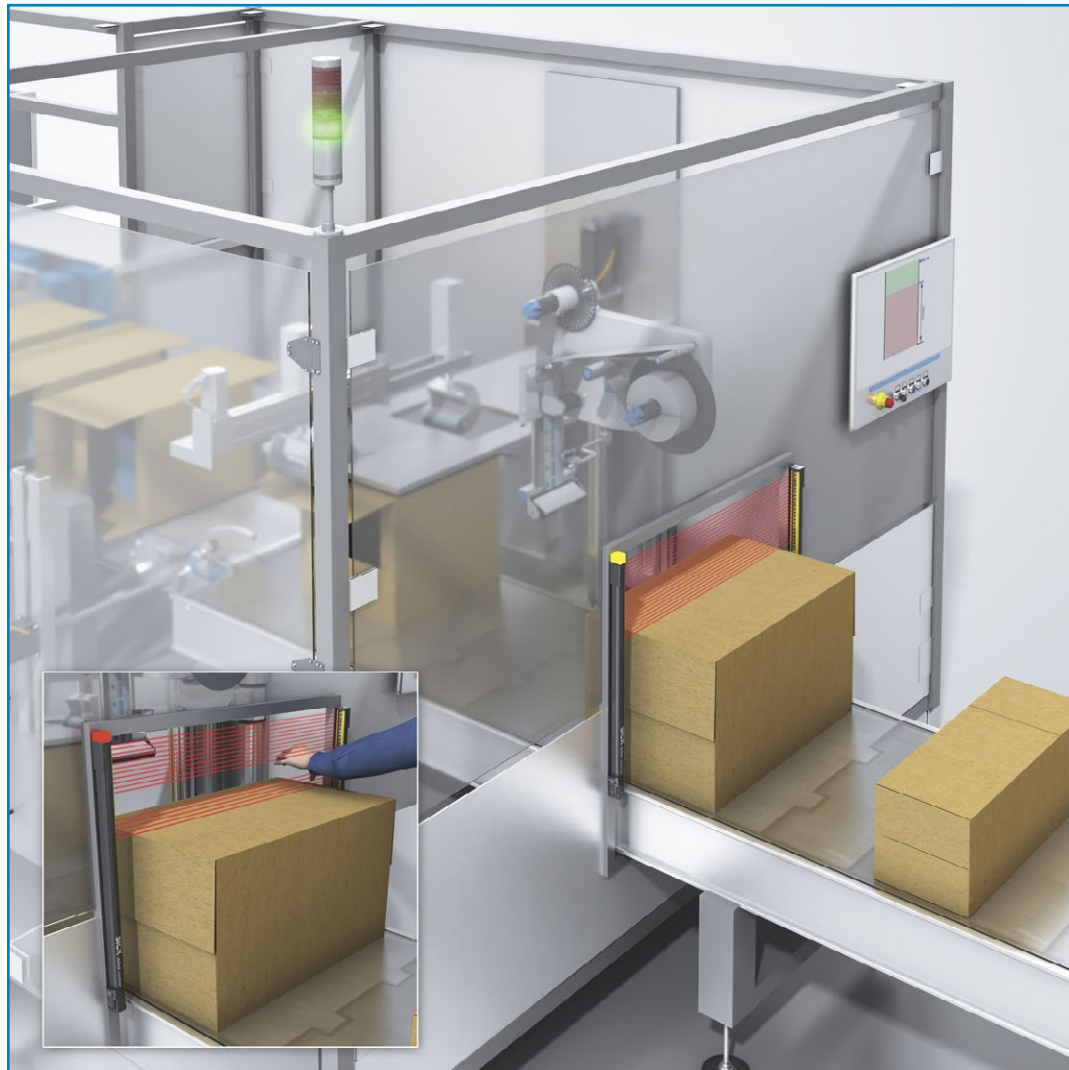

### deTec4 Smart Box Detection

The intelligent pattern recognition function of the deTec4 safety light curtain differentiates people from objects with rectangular contours.

#### Advantages:

- Compared to classic muting solutions and physical tunnels, you save space and reduce the amount of maintenance effort
- Safety light curtain remains active during passage above the object and provides increased safety
- Different box sizes on the conveyor system are automatically detected without any configuration work

#### Limitations:

- Is only suitable for detecting objects with geometrically uniform contours (e.g. rectangles)
- An object height of at least 134 mm is required
- Is not suitable for gaps in the object or stacked boxes

deTec4 Smart Box Detection



## Safety solutions for access protection with automated material flow



### Access gate station

Access to the loading and unloading area is protected by at least two opto-electronic protective devices forming an access gate.

#### Advantages:

- Flexible use with different material contours and sizes
- Also suitable for gaps in the transported material
- Easy implementation thanks to low complexity of the application

#### Limitations:

- Manual material transport and manual release (reset) after interruption of the protective device
- Requires a lot of space for the access gate
- The operator is responsible for correct use (risk of manipulation)

Access gate station

## Safety solutions for access protection with automated material flow

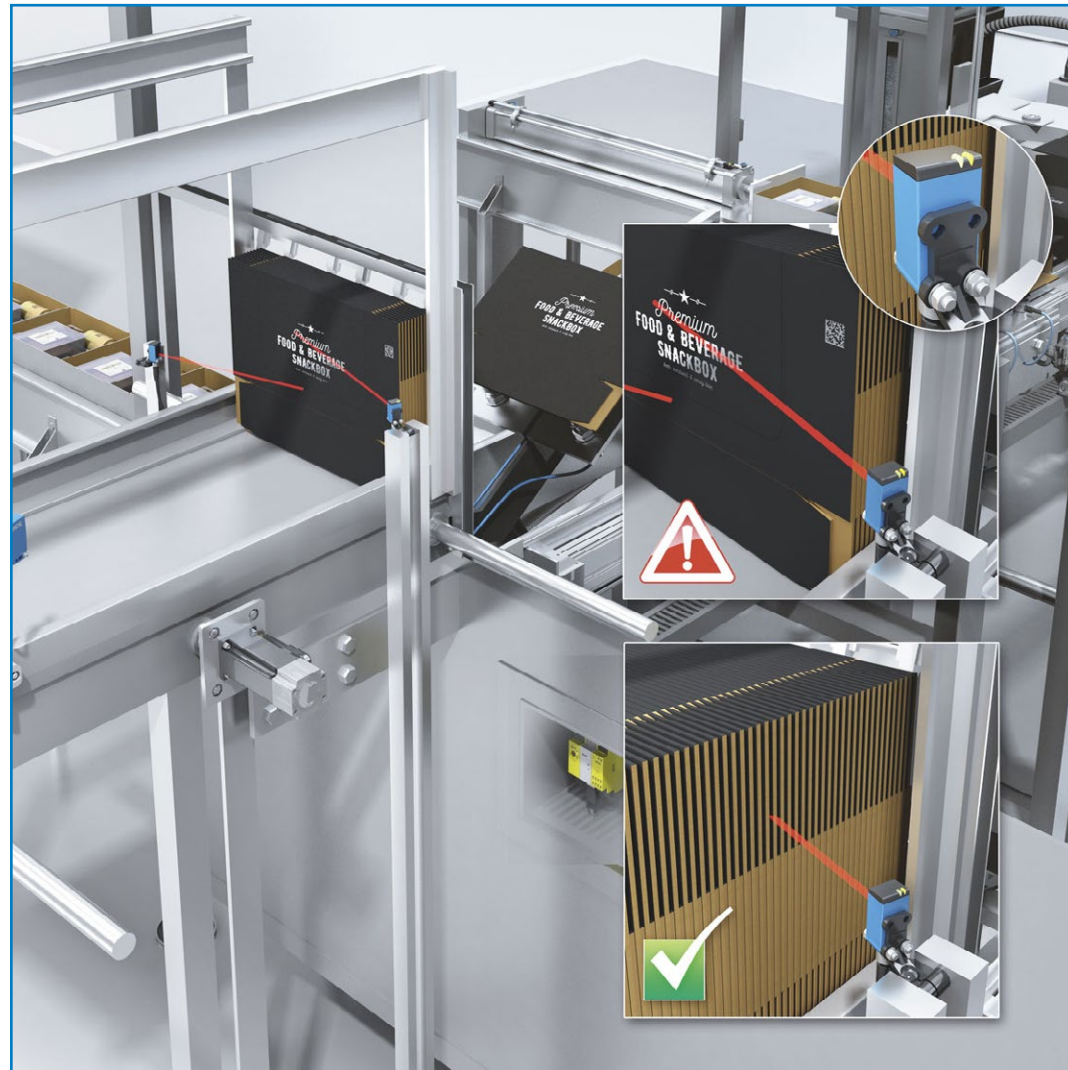

### Safeguard Detector

The material itself serves as a natural separation or physical barrier to the hazardous area. Safeguard Detector ensures the safe detection of a sufficient amount of material.

#### Advantages:

- Compared to physical tunnels, you save space and are more flexible, e.g. for carton erectors on packaging machines
- Easy to integrate into existing safety controllers
- The TÜV-certified safety system saves you time and money when documenting and validating the safety application

#### Limitations:

- Limited range of application regarding the detectable material

Safeguard Detector