

## WT 9-2 P671

V-type  
Photoelectric  
Proximity  
Switch

### Dimension illustration

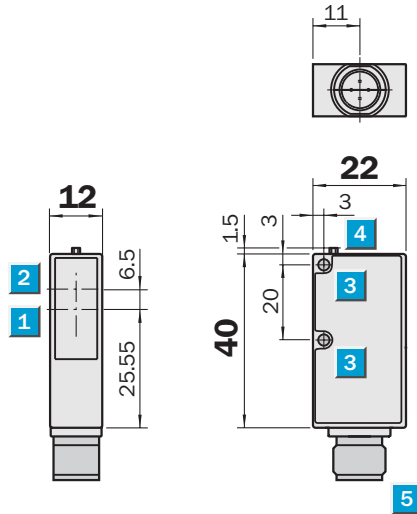

### Setting options

WT 9-2P671

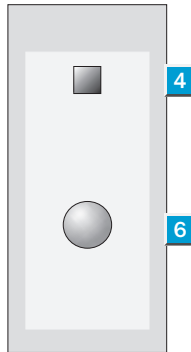

- 1 Axis of the receiver optics
- 2 Axis of the sender optics
- 3 Mounting hole  $\varnothing$  3.2 mm
- 4 LED signal strength indicator
- 5 120 mm cable with plug M 12, 4 pin
- 6 Teach-in button

**Scanning distance**  
10 ... 20 mm

Photoelectric proximity switch

- Emitter LED IR
- Switching frequency 800/s
- Outputs short-circuit protected
- 120 mm cable with plug M 12, 4 pin
- Scanning distance adjustment via teach-in button

### Connection type

WT 9-2P671

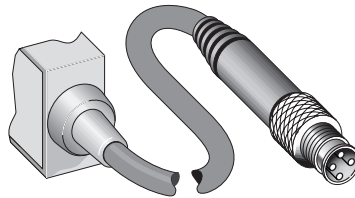

4 pin, M 12 with 120 mm cable

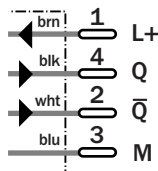

Technical data		WT 9-2	P671									
Scanning distance, teachable <sup>1)</sup>	10 ... 20 mm											
Supply voltage $V_S$ <sup>2)</sup>	10 ... 30 VDC											
Ripple <sup>3)</sup>	$\leq 5 V_{pp}$											
Current consumption <sup>4)</sup>	$\leq 30 \text{ mA}$											
Light source <sup>5)</sup>	LED, infrared											
Light spot diameter	3 mm at a distance of 20 mm											
Switching outputs	PNP, Q und $\bar{Q}$											
Signal voltage HIGH	$V_S - 2.9 \text{ V}$											
Signal voltage LOW <sup>6)</sup>	Approx. 0 V											
Output current $I_A$ max.	$\leq 100 \text{ mA}$											
Response time <sup>7)</sup>	$\leq 625 \mu\text{s}$											
Switching frequency max. <sup>8)</sup>	800/s											
Connection technology	Cable, 120 mm, with plug M 12, 4 pin											
VDE protection class <sup>9)</sup>	<input type="checkbox"/>											
Protection type	IP 67											
Protection circuits <sup>10)</sup>	A, B, C											
Ambient temperature <sup>11)</sup>	Operation $-40 \dots +60 \text{ }^\circ\text{C}$ Storage $-40 \dots +75 \text{ }^\circ\text{C}$											
Weight with cable 120 mm	Approx. 80 g											
Housing material	ABS											

<sup>1)</sup> Object with 90% reflectance (referred to standard white DIN 5033)  
<sup>2)</sup> Limit values  
<sup>3)</sup> Must be within  $V_S$  tolerances  
<sup>4)</sup> Without load

<sup>5)</sup> Average service life at room temperature 100,000 h at  $T_U = +25 \text{ }^\circ\text{C}$   
<sup>6)</sup> At  $T_U = +25 \text{ }^\circ\text{C}$  and 100 mA output current

<sup>7)</sup> With resistive load  
<sup>8)</sup> With light/dark ratio 1:1  
<sup>9)</sup> Withstand voltage 50 V DC

<sup>10)</sup> A = supply connections reverse polarity protected  
 B = outputs short-circuit protected  
 C = interference suppression  
<sup>11)</sup> Do not distort cable below 0 °C

## Teach-in function

### Programming via teach-in button.

#### Simple programming:

Position object in the beam and push the button: finished;  
 LED confirms the teach-in procedure.

#### Teach-in values can be stored.

### Two operating modes:

**Default setting:** short teach-in time (< 8 s);  
 for standard applications;  
 approx. double reserve via switching threshold;  
 LED lights continuously.

**Precise setting:** long teach-in time (> 8 s);  
 for precise applications;  
 small switching hysteresis;  
 LED blinks.

## Scanning distance

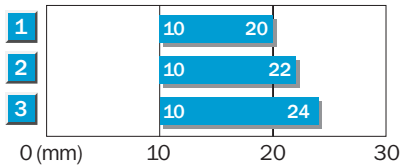

Operating distance

- 1 Scanning range on black, 6% reflectance
- 2 Scanning range on gray, 18% reflectance
- 3 Scanning range on white, 90% reflectance

## Ordering information

Type	Order no.
WT 9-2P671	1 019 656

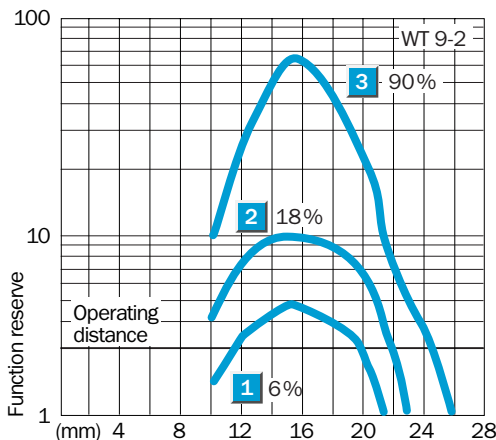

### Great Britain

Erwin Sick Ltd.  
 Waldkirch House  
 39 Hedley Road, St. Albans  
 Hertfordshire AL 1 5BN  
 ☎ +44 17 27-83 11 21  
 Fax +44 17 27-85 67 67  
 erwin@sick.co.uk

### USA

SICK, Inc.  
 6900 West 110th Street  
 Bloomington, MN 55438  
 ☎ +1 (952) 9 41-67 80  
 Fax +1 (952) 9 41-92 87  
 WATS: 1-800-325-7425  
 info@sickoptical.com

### Australia

Erwin Sick Optic-Electronic  
 Pty. Ltd. Head Office, P.O. Box 214  
 899 Heidelberg Road  
 Ivanhoe, Vic. 3079, Australia  
 ☎ +61 39 49 74 10 0  
 (0 08) 33 48 02 - toll free  
 Fax +61 39 49 71 18 7  
 sick@werple.net.au

