

ReLy OSSD1

Safety relay

RLY3-OSSD100S14

SICK
Sensor Intelligence.



Described product

ReLy OSSD1

Manufacturer

SICK AG
Erwin-Sick-Str. 1
79183 Waldkirch
Germany

Legal information

This work is protected by copyright. Any rights derived from the copyright shall be reserved for SICK AG. Reproduction of this document or parts of this document is only permissible within the limits of the legal determination of Copyright Law. Any modification, abridgment or translation of this document is prohibited without the express written permission of SICK AG.

The trademarks stated in this document are the property of their respective owner.

© SICK AG. All rights reserved.

Original document

This document is an original document of SICK AG.



Contents

1	Ordering information.....	5
1.1	Ordering information for ReLy.....	5
2	About this document.....	6
2.1	Purpose of this document.....	6
2.2	Scope.....	6
2.3	Target groups and structure of these operating instructions.....	6
2.4	Additional information.....	6
2.5	Symbols and document conventions.....	7
3	Safety information.....	8
3.1	General safety notes.....	8
3.2	Intended use.....	8
3.3	Improper use.....	8
3.4	Requirements for the qualification of personnel.....	8
4	Product description.....	10
4.1	Construction and function.....	10
4.2	Product characteristics.....	10
4.2.1	Device overview.....	10
4.2.2	Interfaces.....	10
4.2.3	Compatible sensor types.....	10
4.2.4	External device monitoring.....	11
4.2.5	Status indicators.....	11
5	Project planning.....	12
5.1	Manufacturer of the machine.....	12
5.2	Operating entity of the machine.....	12
5.3	Design.....	12
5.4	Electrical integration.....	13
5.4.1	Enabling current paths.....	13
5.4.2	Feedback current path.....	13
5.4.3	Connection diagrams.....	14
5.5	Testing plan.....	14
5.5.1	Minimum requirements for the regular thorough check.....	14
6	Mounting.....	15
6.1	Safety.....	15
6.2	Mounting procedure.....	15
6.3	Disassembly.....	16
6.4	Module exchange.....	16
7	Electrical installation.....	18
7.1	Device connection.....	18

8	Commissioning.....	20
8.1	Safety.....	20
8.2	Thorough check.....	20
9	Troubleshooting.....	21
9.1	Safety.....	21
9.2	Status indicator (LED).....	21
10	Decommissioning.....	22
10.1	Disposal.....	22
11	Technical data.....	23
11.1	Data sheet.....	23
11.2	Dimensional drawings.....	27
11.3	Internal circuitry.....	28
12	Annex.....	29
12.1	Compliance with EU directives.....	29
13	List of figures.....	30
14	List of tables.....	31

1 Ordering information

1.1 Ordering information for ReLy

Table 1: Ordering information

Part	Usage	Type	Part number
ReLy OSSD1	Opto-electronic protective devices	RLY3-OSSD100S14	1119029

2 About this document

2.1 Purpose of this document

These operating instructions contain the information required during the life cycle of the safety relay.

These operating instructions must be made available to everyone who works with the safety relay.

2.2 Scope

This document only applies to a ReLy safety relay with the following type label entries in the Operating Instructions field:

- 8026646

2.3 Target groups and structure of these operating instructions

These operating instructions are intended for the following target groups: project developers (planners, developers, designers), installers, electricians, safety experts (such as CE authorized representatives, compliance officers, people who test and approve the application), operators, and maintenance personnel.

These operating instructions are organized by the life phases of the device: project planning, mounting, electrical installation, commissioning, operation and maintenance.

The table below shows the target groups and how – for many applications – these are typically divided up between the manufacturer and the entity operating the machine in which the device is to be integrated:

Area of responsibility	Target group	Specific chapters of these operating instructions ¹⁾
Manufacturer	Project developers (planners, developers, designers)	"Project planning", page 12 "Technical data", page 23
	Installers	"Mounting", page 15
	Electricians	"Electrical installation", page 18
	Safety experts	"Project planning", page 12 "Commissioning", page 20 "Technical data", page 23
Operating entity	Operators	"Troubleshooting", page 21
	Maintenance personnel	"Troubleshooting", page 21 "Ordering information", page 5

¹⁾ Chapters not listed here are intended for all target groups. All target groups must follow all of the safety and warning instructions in all chapters of the operating instructions!

In other applications, the operating organization is also the manufacturer of the equipment with the corresponding allocation of the target groups.

2.4 Additional information

www.sick.com

The following information is available on the Internet:

- This document in other languages
- Data sheets and application examples
- CAD data and dimensional drawings

- Certificates (e.g. EU declaration of conformity)
- Guide for Safe Machinery Six steps to a safe machine

2.5 Symbols and document conventions

The following symbols and conventions are used in this document:

Safety notes and other notes



DANGER

Indicates a situation presenting imminent danger, which will lead to death or serious injuries if not prevented.



WARNING

Indicates a situation presenting possible danger, which may lead to death or serious injuries if not prevented.



CAUTION

Indicates a situation presenting possible danger, which may lead to moderate or minor injuries if not prevented.



NOTICE

Indicates a situation presenting possible danger, which may lead to property damage if not prevented.



NOTE

Indicates useful tips and recommendations.

Instructions to action

- ▶ The arrow denotes instructions to action.
- 1. The sequence of instructions for action is numbered.
- 2. Follow the order in which the numbered instructions are given.
- ✓ The check mark denotes the result of an instruction.

LED symbols

These symbols indicate the status of an LED:

- The LED is off.
- ◐ The LED is flashing.
- The LED is illuminated continuously.

3 Safety information

3.1 General safety notes

**DANGER**

If the safety component is integrated incorrectly, the dangerous state may be ended too late.

- ▶ Plan the integration of the safety component in accordance with the machine requirements, see "Project planning", page 12.

**DANGER**

Hazard due to lack of effectiveness of the protective device

In the case of non-compliance, it is possible that the dangerous state of the machine may not be stopped or not stopped in a timely manner.

- ▶ Please read this document carefully and make sure that you understand the content fully before working with the device.
- ▶ Follow all safety notes in this document.

Improper installation or manipulation can lead to serious injuries.

3.2 Intended use

The safety relay is an expansion module for sensors or safety devices with OSSDs for switching safety-related circuits on and off.

The safety relay complies with class A, group 1 as per EN 55011. Group 1 encompasses all ISM devices in which intentionally generated and/or used conductor-bound RF energy that is required for the inner function of the device itself occurs.

The safety relay must only be used within the limits of the prescribed and specified technical data and operating conditions at all times.

Incorrect use, improper modification or manipulation of the safety relay will invalidate any warranty from SICK; in addition, any responsibility and liability of SICK for damage and secondary damage caused by this is excluded.

3.3 Improper use

The safety relay is **not** suitable for the following applications (this list is not exhaustive):

- At altitudes of over 4,000 m above sea level
- In explosion-hazardous areas

3.4 Requirements for the qualification of personnel

The protective device must be planned in, installed, connected, commissioned, and serviced by qualified safety personnel only.

Project planning

For project planning, a person is considered competent when he/she has expertise and experience in the selection and use of protective devices on machines and is familiar with the relevant technical rules and national work safety regulations.

Mechanical mounting, electrical installation, and commissioning

For the task, a person is considered qualified when he/she has the expertise and experience in the relevant field and is sufficiently familiar with the application of the protective device on the machine to be able to assess whether it is in an operationally safe state.

Operation and maintenance

For operation and maintenance, a person is considered competent when he/she has the expertise and experience in the relevant field and is sufficiently familiar with the application of the protective device on the machine and has been instructed by the machine operator in its operation.

4 Product description

4.1 Construction and function

The safety relay ReLy OSSD1 is an electrical switching device with inputs and outputs.

The safety capable inputs of the safety relay are connected to safety sensors.

2 safety capable inputs control the internal relays, which are used to reliably switch the enabling current paths.

Actuators with positively guided contacts are connected to the enabling current paths.

4.2 Product characteristics

4.2.1 Device overview

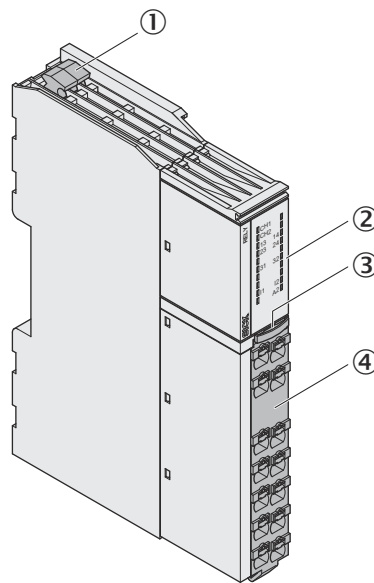

Figure 1: Device overview

- ① Device unlocking
- ② LEDs
- ③ Front connector unlocking
- ④ Front connector

4.2.2 Interfaces

Inputs

- 2 safety capable inputs

Outputs

- 2 enabling current paths (safe)
- Feedback current path (for use as external device monitoring, not safe)

4.2.3 Compatible sensor types

The safety relay is suitable for:

- Safety sensors and safety switches with OSSD output, e.g. Electro-sensitive protective equipment (ESPE) with a single-channel or dual-channel monitored active switching output with cross-circuit detection (OSSD) and safety controllers with monitored semiconductor outputs

4.2.4 External device monitoring

The feedback current path is used as external device monitoring for the monitoring by the base device.

4.2.5 Status indicators

LEDs

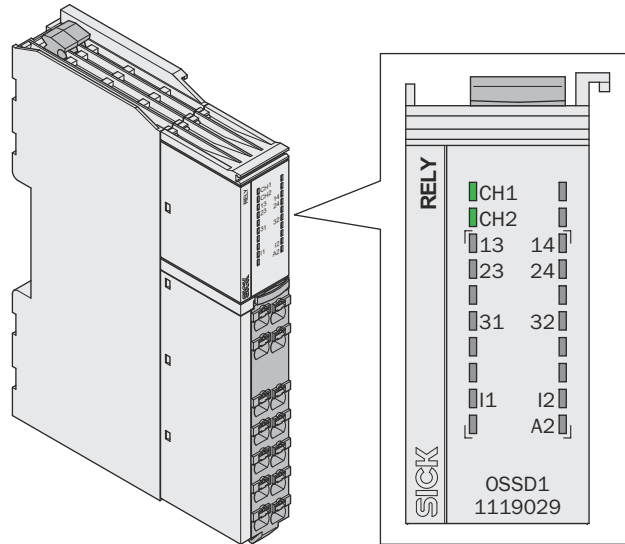

Figure 2: LEDs

The labeled positions are only partially assigned LEDs. The positions and their labeling (except for the upper 2 lines) also show the pin assignment of the terminals on the front connector.

Table 2: Safety relay indicators

Labeling	Color	Function
CH1	Green	OSSD 1 safety capable input
CH2	Green	OSSD 2 safety capable input

Further topics

- ["Status indicator \(LED\)", page 21](#)

5 Project planning

5.1 Manufacturer of the machine



DANGER

Failure to comply with manufacturer's obligations

Hazard due to lack of effectiveness of the protective device

- ▶ Carry out a risk assessment before using the safety relay.
 - ▶ Do not manipulate, open or modify the components of the safety relay.
 - ▶ Make sure the safety relay is only repaired by the manufacturer or by someone authorized by the manufacturer. Improper repair can lead to a loss of the protective function.
-

5.2 Operating entity of the machine



DANGER

Failure to observe operator obligations

Hazard due to lack of effectiveness of the protective device

- ▶ Changes to the machine and changes to the mechanical mounting of the safety relay necessitate a new risk assessment. The results of this risk assessment may require the entity operating the machine to meet the obligations of a manufacturer.
 - ▶ Apart from the procedures described in this document, the components of the safety relay must not be opened or modified.
 - ▶ Do not carry out any repair work on components. Improper repair of the safety relay can lead to a loss of the protective function.
-

5.3 Design

The safety relay must be installed in a control cabinet with an enclosure rating of IP54 or higher.

The safety relay must be installed on a mounting rail (35 mm) in accordance with IEC 60715.

Space requirements in the control cabinet

To ensure sufficient air circulation and cooling, sufficient distance must be kept in the control cabinet above and below the safety relay.

Sufficient distance must be kept for the connected cables before the module (front side).

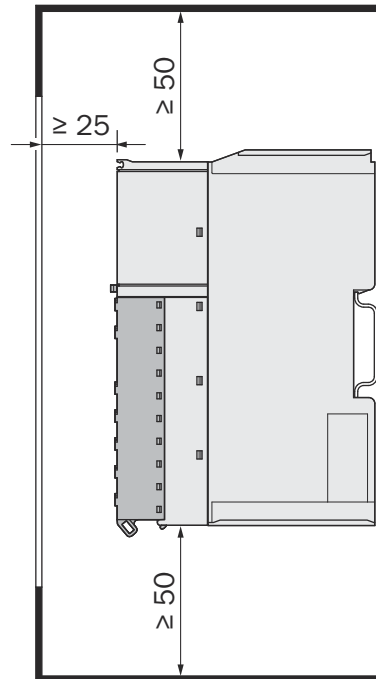

Figure 3: Distances in control cabinet

Required distance:

- Above and below the module: ≥ 50 mm
- In front of the module: ≥ 25 mm

5.4 Electrical integration

Important information



NOTE

The device achieves overvoltage category III if feedback current path 31/32 is supplied by the same voltage supply as the upstream OSSDs (safety extra-low voltage). Connected devices must be also have overvoltage category III.

5.4.1 Enabling current paths



DANGER

Hazard due to lack of effectiveness of the protective device

- ▶ Ensure the enabling current paths are supplied by the same voltage supply.

5.4.2 Feedback current path

The feedback current path is used as external device monitoring for the monitoring by the base device.

The status of the feedback current path (31, 32) changes as soon as the safe enabling current paths (13, 14, 23, 24) switch. The feedback current path is not safe.

Table 3: Switching behavior of feedback current path

State of enabling current paths	State of feedback current path
Closed	Open
Open	Closed

5.4.3 Connection diagrams

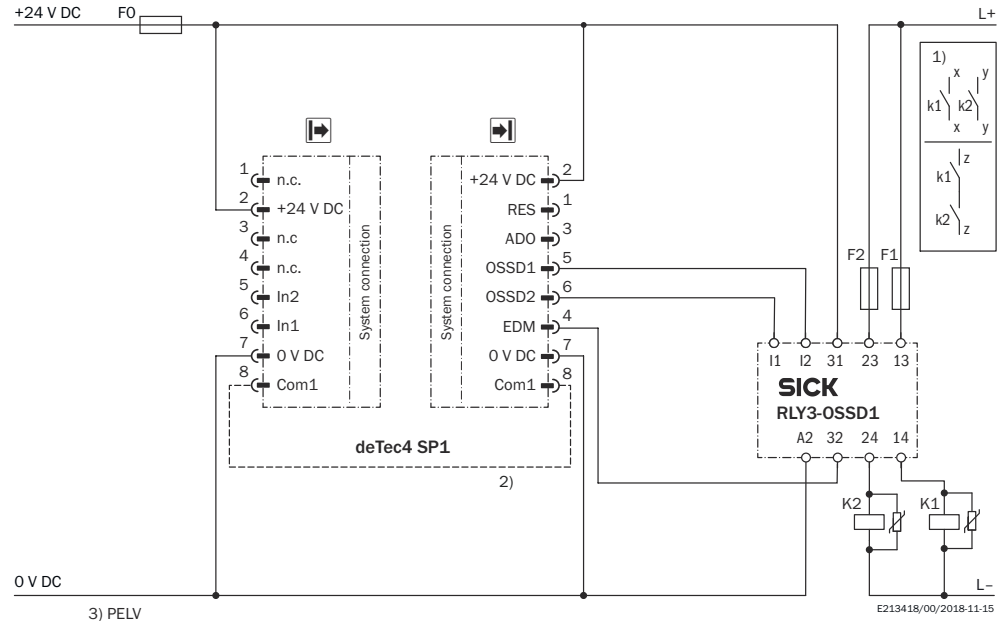

Figure 4: ReLy OSSD1 connection diagram

5.5 Testing plan

The safety relay must be thoroughly checked by appropriately qualified safety personnel during commissioning, after modifications, and at regular intervals, [see "Thorough check", page 20](#).

The regular thorough checks serve to assess the effectiveness of the safety relay and to identify defects as a result of modifications or other influences (e.g., damage or manipulation).

The manufacturer and user must define the type and frequency of the thorough checks on the machine on the basis of the application conditions and the risk assessment. Determination of the thorough checks must be documented in a traceable manner.

5.5.1 Minimum requirements for the regular thorough check

The following thorough checks must be carried out at regular intervals:

- Thorough check of the housing for damage
- Thorough check of the cables for damage
- Thorough check of the safety relay for signs of misuse or manipulation
- Thorough check of the safety function

The required interval for performing these thorough checks depends on the applicable safety capability of the overall application, [see table 6, page 23](#).

6 Mounting

6.1 Safety



DANGER

Hazard due to unexpected starting of the machine

Hazard due to electrical voltage

- ▶ Make sure that the outputs of the safety relay have no effect on the machine during mounting and electrical installation.
- ▶ Make sure that the safety relay and the connected components are isolated from all voltage sources during mounting and electrical installation of the device and during mounting/dismantling of the front connector.



NOTICE

Enclosure rating IP20 only applies if the front connector is mounted.

6.2 Mounting procedure

Prerequisites

- Mounting is done in accordance with EN 50274 and electrical installation in accordance with IEC 60204-1 in the control cabinet with enclosure rating IP54.
- Mounting must be done on a non-flammable base.
- Mounting is done on a 35 mm mounting rail (IEC 60715).
- The mounting rail is connected to the functional earth.
- The module is installed with a vertical orientation (on a horizontal mounting rail).
- There is at least 50 mm of space for air circulation above and below the module.
- There is at least 25 mm of space in front of the module (front side). More space may be needed depending on the connections.

Approach

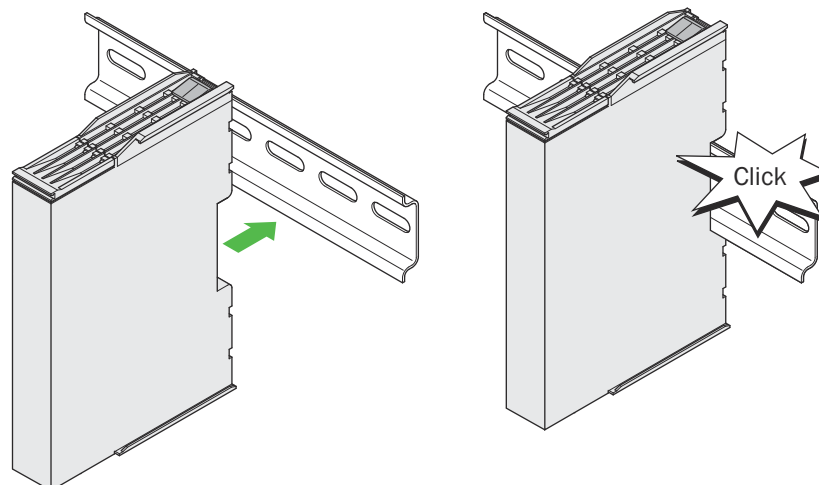

Figure 5: Mounting

- ▶ Attach module to mounting rail.

6.3 Disassembly

Prerequisites

- Electrician screwdriver (slotted screwdriver)

Approach

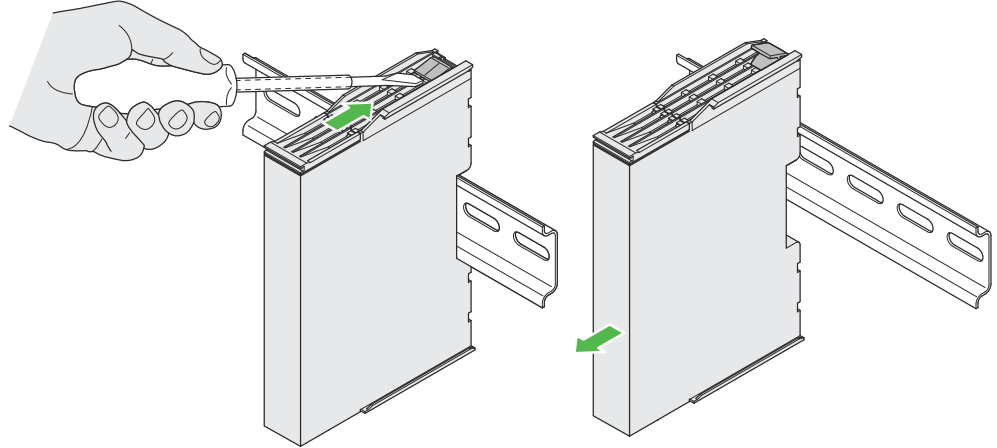

Figure 6: Disassembly

1. Press the unlocking mechanism on the upper side of the module towards the back using the electrician screwdriver.
2. Loosen module from the mounting rail.

6.4 Module exchange

Approach

1. Disconnect module and the connected components from all voltage sources.
2. Take front connector with connected cables off the defective device: Press the unlocking mechanism of the front connector downwards and pull out the front connector.

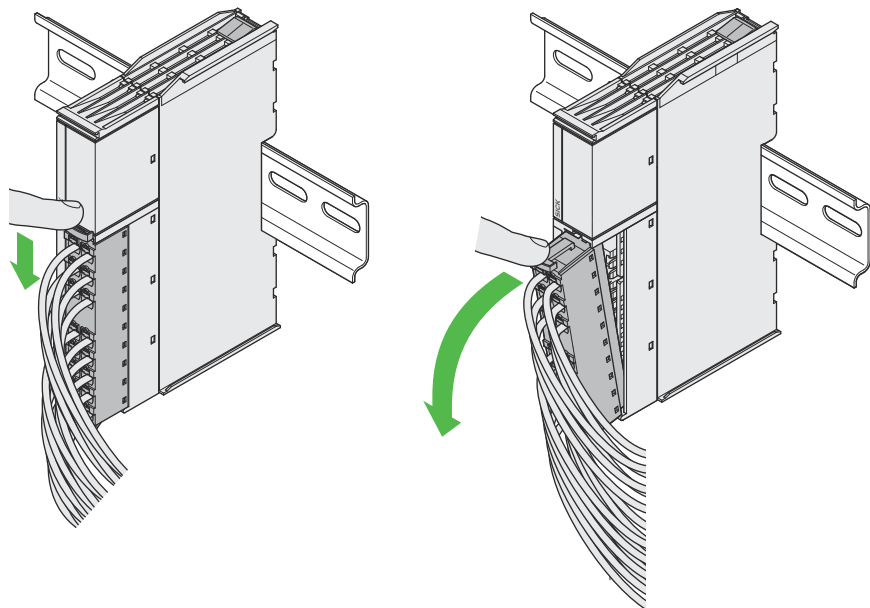

Figure 7: Dismantle front connector

3. Dismantle the defective module.
4. Mount new module.
5. Mount front connector with connected cables to the new module: First mount in the module with bent hook and then engage in the housing.

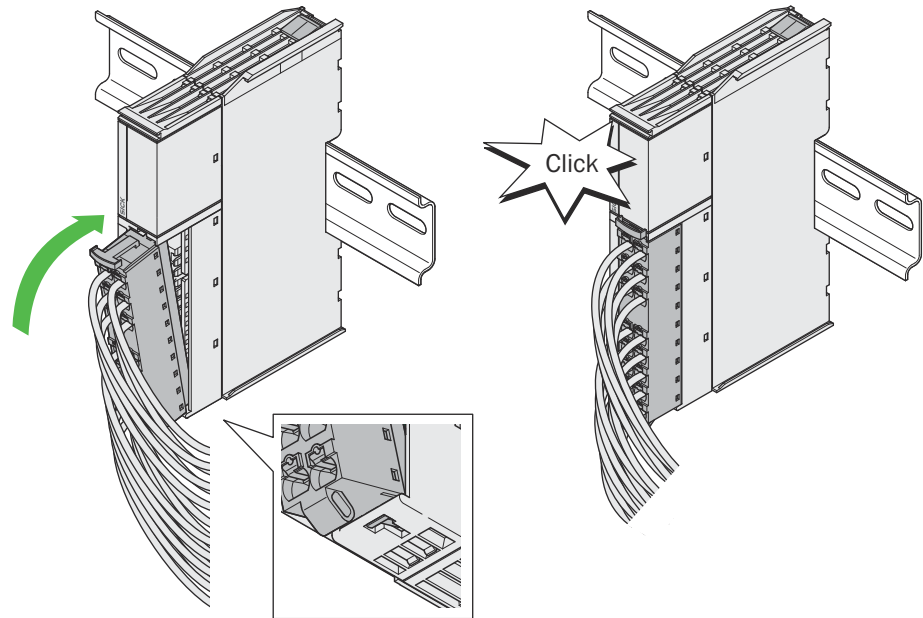

Figure 8: Mount the front connector

- ✓ The front connector engages with an audible click.

7 Electrical installation

7.1 Device connection

Important information



DANGER

Hazard due to unexpected starting of the machine

Hazard due to electrical voltage

- ▶ Make sure that the outputs of the safety relay have no effect on the machine during mounting and electrical installation.
 - ▶ Make sure that the safety relay and the connected components are isolated from all voltage sources during mounting and electrical installation of the device and during mounting/dismantling of the front connector.
-



NOTICE

Enclosure rating IP20 only applies if the front connector is mounted.

Prerequisites

- Electrical installation is done in conformity with IEC 60204-1.
- The mounting rail is connected to the functional earth.
- The voltage supply and connected signals meet the requirements for SELV/PELV (EN 61140) or NEC Class 2 (UL 1310).
- The external voltage supply must be capable of bridging a brief power failure of 20 ms as specified in IEC 60204-1. Suitable power supply units are available as accessories from SICK.
- The safety outputs and external device monitoring (EDM) must be wired within the control cabinet.
- When using the safety relay with voltages larger than the safety extra-low voltage: The N/C contacts of the controlled contactors must be safely isolated from the other contactor contacts.
- Contact fuse with safety fuse gG or circuit breaker C: 6 A, maximum short-circuit current $I \leq 400$ A
- The ground connection of all connected devices must have the same potential as A2.
- All connected devices and the reset pushbutton comply with the required category in accordance with ISO 13849-1 and SILCL in accordance with IEC 62061 (e.g. shielded single sheathed cables, separate installation).

Pin assignment

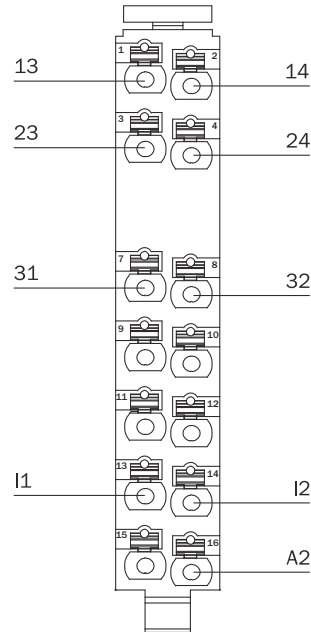

Figure 9: Terminals on front connector

Table 4: Pin assignment of the terminals

Terminal	Description
13, 14 ^{1) 2)}	Enabling current path
23, 24 ^{1) 2)}	Enabling current path
31	Feedback current path, 24 V DC
32	Feedback current path, for connection to the EDM input of the basic device
I1	CH1 input (safety capable input for OSSD 1)
I2	CH2 input (safety capable input for OSSD 2) ³⁾
A2	Voltage supply 0 V DC

¹⁾ The enabling current paths must be supplied by the same voltage supply.

²⁾ The enabling current path and external device monitoring (EDM) must be wired within the control cabinet.

³⁾ With single-channel base device: Connect jumper between I1 and I2.

Complementary information

To protect and increase the service life of contact outputs, equip all connected loads with varistors or RC elements. The response times will increase depending on the suppressor used.

Further topics

- ["Connection diagrams", page 14](#)

8 Commissioning

8.1 Safety



DANGER

Dangerous state of the machine

During commissioning, the machine or the protective device may not yet behave as you have planned.

- ▶ Make sure that there is no-one in the hazardous area during commissioning.
-

8.2 Thorough check

Requirements for the thorough check during commissioning and in certain situations

The device and its application must be thoroughly checked in the following situations:

- Before commissioning
- After changes to the configuration or the safety function
- After changes to the mounting or the electrical installation
- After exceptional events, such as after manipulation has been detected, after modification of the machine, or after replacing components

The thorough check ensures the following:

- All relevant regulations are complied with and the device is effective in all of the machine's operating modes.
- The documentation accurately reflects the state/condition of the machine, including the protective device.

The thorough checks must be carried out by qualified safety personnel or specially qualified and authorized personnel, and must be documented in a traceable manner.

9 Troubleshooting

9.1 Safety



DANGER

Hazard due to lack of effectiveness of the protective device

In the case of non-compliance, it is possible that the dangerous state of the machine may not be stopped or not stopped in a timely manner.

- ▶ Immediately shut the machine down if the behavior of the machine cannot be clearly identified.
- ▶ If a machine fault cannot be definitively determined or safely rectified, immediately shut the machine down.
- ▶ Secure the machine so that it cannot switch on unintentionally.



NOTE

Additional information on troubleshooting can be found at the responsible SICK subsidiary.

9.2 Status indicator (LED)

Status indicator (LED)

Table 5: Operational statuses

LED	Status	Possible cause
CH1	● Green	Voltage on I1
CH2	● Green	Voltage on I2

10 Decommissioning

10.1 Disposal

Approach

- ▶ Always dispose of unusable devices in accordance with national waste disposal regulations.



Complementary information

SICK will be glad to help you dispose of these devices on request.

11 Technical data

11.1 Data sheet

Table 6: Safety-related parameters

	Desired safety integrity level (IEC 61508) ¹⁾		
	SIL3	SIL2	SIL1
SIL claim limit (IEC 62061)	SILCL3	SILCL2	SILCL1
Category (ISO 13849-1)	4	3	3
Performance level (ISO 13849-1) ²⁾	PL e	PL d	PL c
Hardware error tolerance	1		
Maximum test interval of the safety function	1 month	1 year	-
MTTF _D (single channel) (ISO 13849-1)	300 years	100 years	100 years
PFH _D (mean probability of a dangerous failure per hour) ³⁾			
For operating heights ≤ 4,000 m above sea level	1 × 10 ⁻⁹	1 × 10 ⁻⁸	1 × 10 ⁻⁷
PFD _{avg} (mean probability of a dangerous failure on demand) ³⁾			
For operating heights ≤ 4,000 m above sea level	5 × 10 ⁻⁵	5 × 10 ⁻⁴	5 × 10 ⁻³
T _M (mission time)	20 years (ISO 13849-1)		
Safe status when a fault occurs	The safety relay has no internal fault detection and is unable to assume a safe status in the event of a fault. Fault detection is performed by the connected safety-related logic unit.		
Stop category	0 (IEC 60204-1)		

1) The required safety integration level depends on your application.

2) In order to reach at least SIL2 / PL, an external diagnosis with DC ≥ 99% must be applied (i.e., external device monitoring must be connected).

3) If service life curve is adhered to, [see figure 11, page 27](#).

Table 7: Mechanical data

Weight	130 g
Mounting	Mounting rail (IEC 60715)
Connection type	Spring terminals
Stripping length	8 mm
Wire cross-section	
Single wire (1×)	0.2 mm ² ... 1.5 mm ²
Fine wire (1×)	0.2 mm ² ... 1.5 mm ²
Fine wire with ferrules (2 ×, same cross-section) with TWIN ferrule with plastic collar	≤ 0.5 mm ²
Fine wire with ferrules with or without collar (1×)	0.25 mm ² ... 1.0 mm ²

For UL and CSA applications	26 AWG ... 14 AWG (use only copper wire (60/75 °C))
-----------------------------	--

Table 8: Electrical data - safety capable inputs (I1, I2)

Rated voltage	24 V DC
Input voltage HIGH	24 V DC (15 V DC ... 30 V DC)
Input voltage LOW	0 V DC (-3 V DC ... 5 V DC)
Input capacity	≤ 15 nF
Input current	2 × ≤ 50 mA
Power consumption	≤ 1.5 W 2.5 W from hardware version 1.10.0
Test pulse width	≤ 1,000 μs
Test pulse rate	≤ 10 Hz
Reset time	≤ 50 ms

Table 9: Electrical data - enabling current paths (13, 14, 23, 24) and feedback current path (31, 32)

Response time (opening of enabling current paths)	
Typical	10 ms
Maximum	17 ms 12 ms from hardware version 1.10.0
Number of enabling current paths (normally open, safe)	2
Number of feedback current paths (not safe)	1
Contact type	Positively guided
Contact material	Silver alloy, gold flash plated
Switching voltage for enabling current paths	
At altitudes below 2,000 m above sea level	10 V DC ... 250 V DC 10 V AC ... 250 V AC
At altitudes 2,000 m above sea level ... 4,000 m above sea level	10 V DC ... 150 V DC 10 V AC ... 150 V AC
Switching current for enabling current paths	10 mA ... 6 A, see figure 10, page 26 , see figure 11, page 27
Sum current for enabling current paths	≤ 12 A
Utilization category of enabling current paths	AC-15: 230 V, 5 A (IEC 60947-5-1) DC-13 (0.1 Hz): 24 V, 4 A (IEC 60947-5-1) ¹⁾
DC switching capacity	0.1 W ... 200 W, see figure 10, page 26
AC switching capacity	0.1 VA ... 1500 VA
Switching voltage for feedback current path	15 V DC ... 30 V DC 15 V AC ... 30 V AC
Switching current for feedback current path	3 mA ... 100 mA
Switching frequency	≤ 1 Hz
Mechanical service life	10 × 10 ⁶ Switching operations
Contact fuse with safety fuse gG or circuit breaker C	Max. 6 A
Max. short-circuit protection	≤ 400 A
Rated insulation voltage	

At altitudes up to 2,000 m above sea level	230 V AC
At altitudes up to 2,000 m above sea level ... 4,000 m above sea level	150 V AC
Overvoltage category	III
Contamination degree	2
Rated impulse withstand voltage U_{imp}	6 kV

1) At 0.1 Hz.

Table 10: Ambient data

Enclosure rating	IP20 (IEC 60529)
Ambient operating temperature	
At altitudes up to 2,000 m above sea level (UL/CSA: surrounding air temperature)	-25 °C ... +55 °C
At altitudes 2,000 m above sea level ... 3,000 m above sea level	-25 °C to 50 °C
At altitudes 3,000 m above sea level ... 4,000 m above sea level	-25 °C ... +45 °C
Storage temperature	-25 °C ... +70 °C
Permissible operating height	≤ 4,000 m
Air humidity	10% ... 95%, non-condensing for climatic conditions according to IEC 61131-2
Emitted interference	In accordance with IEC 61000-6-4
Immunity to interference	In accordance with IEC 61326-3-1 In accordance with IEC 61000-6-2 In accordance with IEC 60947-5-1

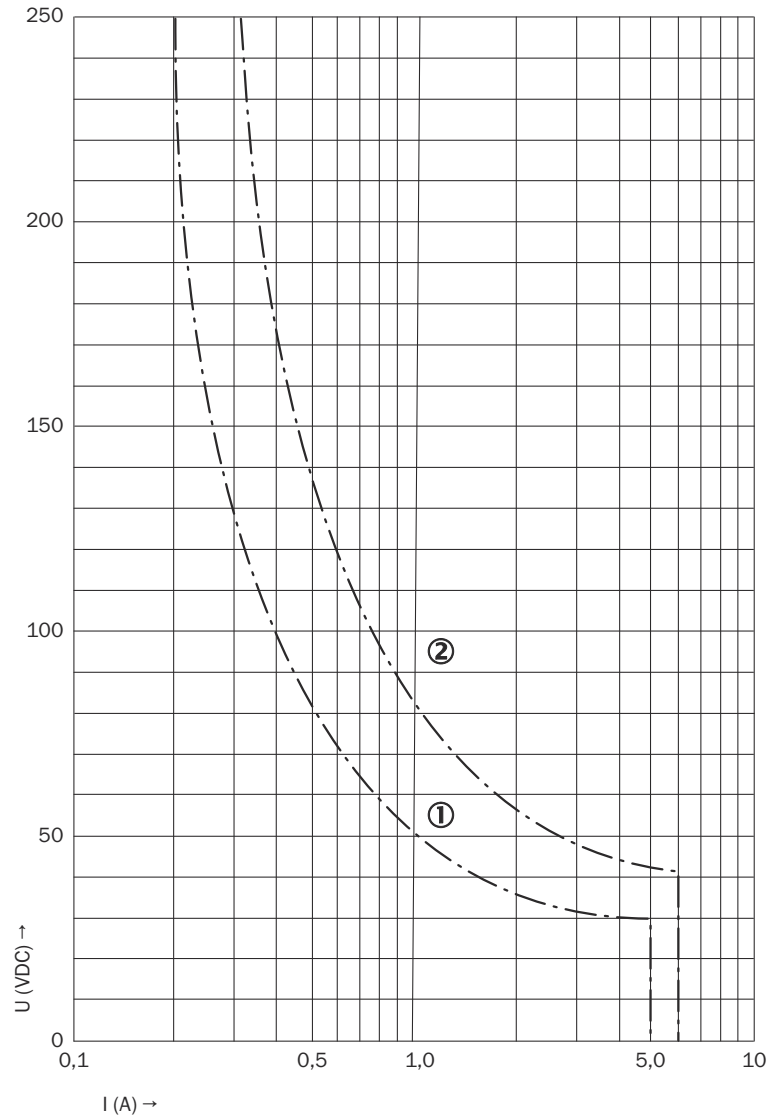

Figure 10: Switch-off delay without continuous arcing

- ① Inductive load L/R 40 ms
- ② Resistive load

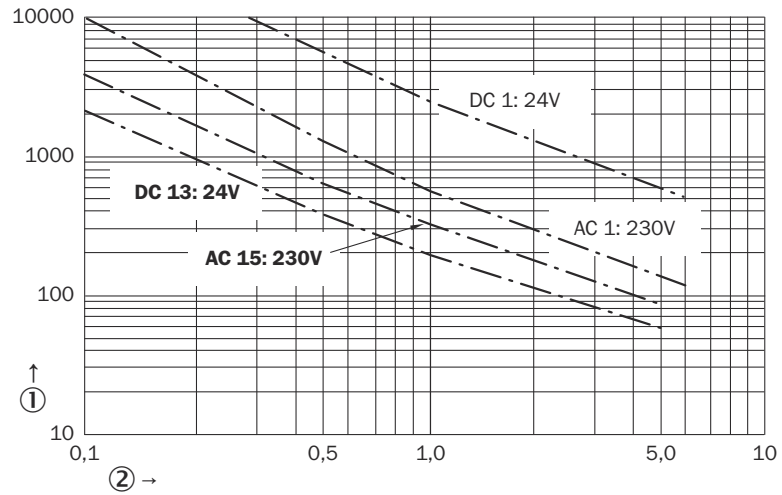

Figure 11: Electrical endurance of contacts 13/14 and 23/24

- ① Switching operations × 1,000
- ② Switching current (A)

11.2 Dimensional drawings

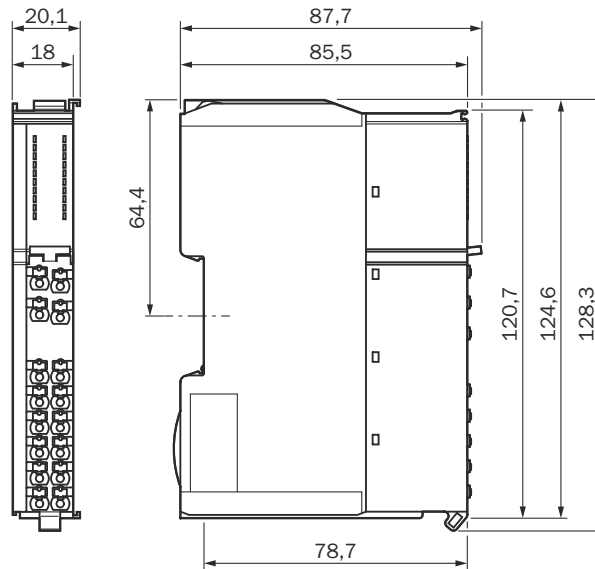

Figure 12: Dimensional drawing

11.3 Internal circuitry

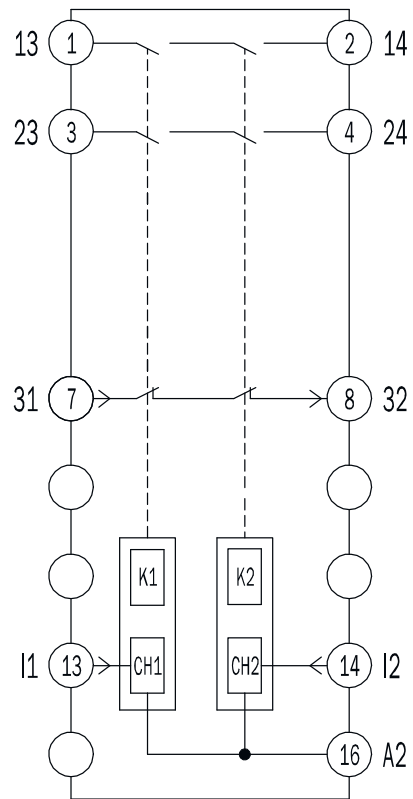

Figure 13: Internal circuitry (hardware version 1.11.0 and above)

12 Annex

12.1 Compliance with EU directives

EU declaration of conformity (extract)

The undersigned, representing the manufacturer, herewith declares that the product is in conformity with the provisions of the following EU directive(s) (including all applicable amendments), and that the standards and/or technical specifications stated in the EU declaration of conformity have been used as a basis for this.

Complete EU declaration of conformity for download

You can call up the EU declaration of conformity and the current operating instructions for the protective device by entering the part number in the search field at www.sick.com (part number: see the type label entry in the "Ident. no." field).

13 List of figures

1.	Device overview.....	10
2.	LEDs.....	11
3.	Distances in control cabinet.....	13
4.	ReLy OSSD1 connection diagram.....	14
5.	Mounting.....	15
6.	Disassembly.....	16
7.	Dismantle front connector.....	16
8.	Mount the front connector.....	17
9.	Terminals on front connector.....	19
10.	Switch-off delay without continuous arcing.....	26
11.	Electrical endurance of contacts 13/14 and 23/24.....	27
12.	Dimensional drawing.....	27
13.	Internal circuitry (hardware version 1.11.0 and above).....	28

14 List of tables

1. Ordering information.....	5
2. Safety relay indicators.....	11
3. Switching behavior of feedback current path.....	13
4. Pin assignment of the terminals.....	19
5. Operational statuses.....	21
6. Safety-related parameters.....	23
7. Mechanical data.....	23
8. Electrical data - safety capable inputs (I1, I2).....	24
9. Electrical data - enabling current paths (13, 14, 23, 24) and feedback current path (31, 32).....	24
10. Ambient data.....	25

Australia

Phone +61 (3) 9457 0600
1800 33 48 02 – tollfree
E-Mail sales@sick.com.au

Austria

Phone +43 (0) 2236 62288-0
E-Mail office@sick.at

Belgium/Luxembourg

Phone +32 (0) 2 466 55 66
E-Mail info@sick.be

Brazil

Phone +55 11 3215-4900
E-Mail comercial@sick.com.br

Canada

Phone +1 905.771.1444
E-Mail cs.canada@sick.com

Czech Republic

Phone +420 234 719 500
E-Mail sick@sick.cz

Chile

Phone +56 (2) 2274 7430
E-Mail chile@sick.com

China

Phone +86 20 2882 3600
E-Mail info.china@sick.net.cn

Denmark

Phone +45 45 82 64 00
E-Mail sick@sick.dk

Finland

Phone +358-9-25 15 800
E-Mail sick@sick.fi

France

Phone +33 1 64 62 35 00
E-Mail info@sick.fr

Germany

Phone +49 (0) 2 11 53 010
E-Mail info@sick.de

Greece

Phone +30 210 6825100
E-Mail office@sick.com.gr

Hong Kong

Phone +852 2153 6300
E-Mail ghk@sick.com.hk

Hungary

Phone +36 1 371 2680
E-Mail ertekezes@sick.hu

India

Phone +91-22-6119 8900
E-Mail info@sick-india.com

Israel

Phone +972 97110 11
E-Mail info@sick-sensors.com

Italy

Phone +39 02 27 43 41
E-Mail info@sick.it

Japan

Phone +81 3 5309 2112
E-Mail support@sick.jp

Malaysia

Phone +603-8080 7425
E-Mail enquiry.my@sick.com

Mexico

Phone +52 (472) 748 9451
E-Mail mexico@sick.com

Netherlands

Phone +31 (0) 30 229 25 44
E-Mail info@sick.nl

New Zealand

Phone +64 9 415 0459
0800 222 278 – tollfree
E-Mail sales@sick.co.nz

Norway

Phone +47 67 81 50 00
E-Mail sick@sick.no

Poland

Phone +48 22 539 41 00
E-Mail info@sick.pl

Romania

Phone +40 356-17 11 20
E-Mail office@sick.ro

Russia

Phone +7 495 283 09 90
E-Mail info@sick.ru

Singapore

Phone +65 6744 3732
E-Mail sales.gsg@sick.com

Slovakia

Phone +421 482 901 201
E-Mail mail@sick-sk.sk

Slovenia

Phone +386 591 78849
E-Mail office@sick.si

South Africa

Phone +27 10 060 0550
E-Mail info@sickautomation.co.za

South Korea

Phone +82 2 786 6321/4
E-Mail infokorea@sick.com

Spain

Phone +34 93 480 31 00
E-Mail info@sick.es

Sweden

Phone +46 10 110 10 00
E-Mail info@sick.se

Switzerland

Phone +41 41 619 29 39
E-Mail contact@sick.ch

Taiwan

Phone +886-2-2375-6288
E-Mail sales@sick.com.tw

Thailand

Phone +66 2 645 0009
E-Mail marcom.th@sick.com

Turkey

Phone +90 (216) 528 50 00
E-Mail info@sick.com.tr

United Arab Emirates

Phone +971 (0) 4 88 65 878
E-Mail contact@sick.ae

United Kingdom

Phone +44 (0)17278 31121
E-Mail info@sick.co.uk

USA

Phone +1 800.325.7425
E-Mail info@sick.com

Vietnam

Phone +65 6744 3732
E-Mail sales.gsg@sick.com

Detailed addresses and further locations at www.sick.com

