

deTec4 C4P-EAxxx3SC05

Safety light curtain

SICK
Sensor Intelligence.



Described product

deTec4 C4P-EAxxx3SC05

Manufacturer

SICK AG
Erwin-Sick-Str. 1
79183 Waldkirch
Germany

Legal information

This work is protected by copyright. Any rights derived from the copyright shall be reserved for SICK AG. Reproduction of this document or parts of this document is only permissible within the limits of the legal determination of Copyright Law. Any modification, abridgment or translation of this document is prohibited without the express written permission of SICK AG.

The trademarks stated in this document are the property of their respective owner.

© SICK AG. All rights reserved.

Original document

This document is an original document of SICK AG.



Contents

1	About this document.....	7
1.1	Purpose of this document.....	7
1.2	Scope.....	7
1.3	Target groups of these operating instructions.....	7
1.4	Additional information.....	8
1.5	Symbols and document conventions.....	8
2	Safety information.....	9
2.1	General safety notes.....	9
2.2	Intended use.....	10
2.3	Inappropriate use.....	10
2.4	Requirements for the qualification of personnel.....	10
3	Product description.....	12
3.1	Structure and function.....	12
3.2	Product characteristics.....	13
3.2.1	Device overview.....	13
3.2.2	Absence of blind zones.....	13
3.2.3	Automatic calibration of the protective field width.....	13
3.2.4	Beam coding.....	14
3.2.5	Alignment aid.....	14
3.2.6	Restart interlock.....	14
3.2.7	External device monitoring (EDM).....	14
3.2.8	Application diagnostic output.....	14
3.2.9	IO-Link.....	15
3.2.10	Near Field Communication (NFC).....	15
3.2.11	System plug.....	16
3.2.12	Flexible control cabinet cabling and status indication on both sides.....	17
3.2.13	Status indicators.....	17
3.3	Example applications.....	20
4	Project planning.....	21
4.1	Manufacturer of the machine.....	21
4.2	Operating entity of the machine.....	21
4.3	Design.....	21
4.3.1	Scanning range and protective field width.....	22
4.3.2	Minimum distance from the hazardous point.....	23
4.3.3	Minimum distance to reflective surfaces.....	25
4.3.4	Protection against interference from systems in close proximity to each other.....	27
4.4	Integration in electrical control.....	30
4.4.1	Restart interlock.....	32
4.4.2	External device monitoring (EDM).....	33

4.4.3	Application diagnostic output.....	34
4.4.4	Connection of sender and receiver.....	34
4.4.5	Laser alignment aid.....	35
4.4.6	IO-Link.....	36
4.5	Testing plan.....	37
4.5.1	Test rod check.....	37
4.5.2	Visual check of the machine and the protective device.....	40
5	Mounting.....	41
5.1	Unpacking.....	41
5.2	Mounting the system plug.....	41
5.3	Installation.....	42
5.3.1	Mounting the QuickFix bracket.....	45
5.3.2	Mounting the FlexFix bracket.....	47
5.3.3	Mounting the upgrade bracket.....	50
6	Electrical installation.....	51
6.1	Safety.....	51
6.2	System connection (M12, 5-pin).....	52
6.3	System connection (M12, 8-pin).....	53
6.4	Extension connection (M12, 5-pin).....	54
7	Configuration.....	55
7.1	Overview.....	55
7.2	Factory settings.....	55
7.2.1	Reset to factory settings.....	56
7.3	Configuration mode.....	57
7.4	Configuring beam coding.....	57
7.5	Configuring the restart interlock.....	58
7.6	Configuring external device monitoring (EDM).....	59
7.7	Configuring application diagnostic output.....	59
7.8	Status indication on both sides.....	60
8	Commissioning.....	61
8.1	Overview.....	61
8.2	Switching on.....	61
8.3	Sender and receiver alignment.....	62
8.3.1	Aligning the sender and receiver.....	62
8.3.2	Alignment with the QuickFix bracket.....	64
8.3.3	Alignment with the FlexFix bracket or with the upgrade bracket.....	65
8.3.4	Indication of the alignment quality.....	65
8.4	Check during commissioning and modifications.....	66
9	Operation.....	67
9.1	Overview.....	67
9.2	Regular thorough check.....	67

9.3	LEDs.....	67
10	Maintenance.....	70
10.1	Regular cleaning.....	70
10.2	Regular thorough check.....	71
11	Troubleshooting.....	72
11.1	Overview.....	72
11.2	Safety.....	72
11.3	Diagnostic LEDs.....	72
11.3.1	Indications when switching on.....	72
11.3.2	Status indication.....	74
11.3.3	Fault indicators.....	76
12	Decommissioning.....	80
12.1	Disposal.....	80
13	Technical data.....	81
13.1	Data sheet.....	81
13.2	Response time.....	84
13.3	Power consumption.....	84
13.4	Length of cable.....	85
13.5	Table of weights.....	86
13.6	Dimensional drawings.....	86
14	Ordering information.....	87
14.1	Scope of delivery.....	87
14.2	Ordering information.....	87
15	Accessories.....	88
15.1	Brackets.....	88
15.2	Mounting accessories.....	89
15.3	Weld spark guard.....	89
15.4	Connectors.....	91
15.5	Alignment aid.....	95
15.6	Deflector mirrors.....	95
15.6.1	Function and use.....	95
15.6.2	Mounting.....	96
15.6.3	Change in scanning range using deflector mirrors.....	96
15.6.4	Deflector mirror PNS75 - ordering information.....	96
15.6.5	Deflector mirror PNS125 - ordering information.....	96
15.7	Mirror columns.....	97
15.8	Device columns.....	97
15.9	Cleaning agent.....	97
15.10	Test rods.....	97
16	Annex.....	98

16.1	Conformities and certificates.....	98
16.1.1	EU declaration of conformity.....	98
16.2	Note on standards.....	98
16.3	Checklist for initial commissioning and commissioning.....	99
17	List of figures.....	100
18	List of tables.....	102

1 About this document

1.1 Purpose of this document

These operating instructions contain information required during the life cycle of the safety light curtain.

These operating instructions are available to all those who work with the safety light curtain.

Please read these operating instructions carefully and make sure that you understand the content fully before working with the safety light curtain.

1.2 Scope

This document applies to the following products:

- Product code: deTec4 C4P-EAxxx3SC05
- “Operating instructions” type label entry: 8028568

Document identification

Document part number:

- This document: 8028570
- Available language versions of this document: 8028568

You can find the current version of all documents at www.sick.com.

Other documents relevant for the product

Table 1: Available documents

Document	Title	Part number
Technical information	deTec4 C4P-EAxxx3SC03, C4P-EAxxx3SC05	8026777

1.3 Target groups of these operating instructions

Some sections of these operating instructions are intended for certain target groups. However, the entire operating instructions are relevant for intended use of the product.

Table 2: Target groups and selected sections of these operating instructions

Target group	Sections of these operating instructions
Project developers (planners, developers, designers)	"Project planning", page 21 "Configuration", page 55 "Technical data", page 81 "Accessories", page 88
Installers	"Mounting", page 41
Electricians	"Electrical installation", page 51
Safety experts (such as CE authorized representatives, compliance officers, people who test and approve the application)	"Project planning", page 21 "Configuration", page 55 "Commissioning", page 61 "Technical data", page 81 "Checklist for initial commissioning and commissioning", page 99
Operators	"Operation", page 67 "Troubleshooting", page 72
Maintenance personnel	"Maintenance", page 70 "Troubleshooting", page 72

1.4 Additional information

www.sick.com

The following information is available on the Internet:

- Data sheets and application examples
- CAD data and dimensional drawings
- Certificates (e.g. EU declaration of conformity)
- Guide for Safe Machinery Six steps to a safe machine

1.5 Symbols and document conventions

The following symbols and conventions are used in this document:

Safety notes and other notes



DANGER

Indicates a situation presenting imminent danger, which will lead to death or serious injuries if not prevented.



WARNING

Indicates a situation presenting possible danger, which may lead to death or serious injuries if not prevented.



CAUTION

Indicates a situation presenting possible danger, which may lead to moderate or minor injuries if not prevented.



NOTICE

Indicates a situation presenting possible danger, which may lead to property damage if not prevented.



NOTE

Indicates useful tips and recommendations.

Instructions to action

- ▶ The arrow denotes instructions to action.
- 1. The sequence of instructions for action is numbered.
- 2. Follow the order in which the numbered instructions are given.
- ✓ The check mark denotes the result of an instruction.

LED symbols

These symbols indicate the status of an LED:

- The LED is off.
- ◑ The LED is flashing.
- The LED is illuminated continuously.

Sender and receiver

These symbols indicate the sender and receiver of the device:

- ➡ The symbol indicates the sender.
- ➠ The symbol indicates the receiver.

2 Safety information

2.1 General safety notes



DANGER

The product can not offer the expected protection if it is integrated incorrectly.

- ▶ Plan the integration of the product in accordance with the machine requirements (project planning).
- ▶ Implement the integration of the product in accordance with the project planning.



DANGER

Death or severe injury due to electrical voltage and/or an unexpected startup of the machine

- ▶ Make sure that the machine is (and remains) disconnected from the voltage supply during mounting and electrical installation.
- ▶ Make sure that the dangerous state of the machine is and remains switched off.



DANGER

Improper work on the product

A modified product may not offer the expected protection if it is integrated incorrectly.

- ▶ Apart from the procedures described in this document, do not repair, open, manipulate or otherwise modify the product.



CAUTION

Laser class 1



Figure 1: Laser class 1

This device has been classified in accordance with the following standards:

- IEC 60825-1:2007/EN 60825-1:2007
- IEC 60825-1:2014/EN 60825-1:2014
- 21 CFR 1040.10 and 1040.11, except for deviations pursuant to Laser Notice No. 50 dated 2007-06-24

The laser is eye-safe. Looking directly into the laser may cause temporary impairments.

The outlet opening of the laser radiation is located in the sender, [see figure 5, page 17](#). The laser is only active when the laser alignment aid is switched on.

Laser identification is located on the rear of the sender.

- ▶ Comply with the latest version of the applicable provisions on laser protection.



CAUTION

If any operating or adjusting devices other than those specified in this document are used or other methods are employed, this can lead to dangerous exposure to radiation.

- ▶ Only use the operating or adjusting devices specified in this document.
 - ▶ Only follow the methods specified in this document.
 - ▶ Do not open the housing, except for the purposes of the installation and maintenance work specified in these operating instructions.
-

2.2 Intended use

The deTec4 C4P-EAxxx3SC05 safety light curtain is an electro-sensitive protective device (ESPE) and is suitable for the following applications:

- Access protection

The product may be used in safety functions.

The safety light curtain is only suitable as access protection if full coverage is guaranteed in the event of an interruption of the protective field.

The deTec4 C4P-EAxxx3SC05 safety light curtain must only be used within the limits of the prescribed and specified technical data and operating conditions at all times.

Any instance of improper use, incorrect modification, or manipulation of the deTec4 C4P-EAxxx3SC05 safety light curtain shall void any warranty provided by SICK AG; furthermore, SICK AG shall not accept any responsibility or liability for any resulting damage and consequential damage.

2.3 Inappropriate use

The safety light curtain works as an indirect protective measure and cannot provide protection from parts thrown out nor from emitted radiation. Transparent objects are not detected.

Among others, the deTec4 C4P-EAxxx3SC05 safety light curtain is not suitable for the following applications:

- Outdoors
- Underwater
- In explosion-hazardous areas
- At altitudes over 3,000 m above sea level
- In environments with increased levels of ionizing radiation

2.4 Requirements for the qualification of personnel

The safety light curtain must only be configured, installed, connected, commissioned and serviced by qualified safety personnel.

Project planning

You need safety expertise to implement safety functions and select suitable products for that purpose. You need expert knowledge of the applicable standards and regulations.

Mounting, electrical installation and commissioning

You need suitable expertise and experience. You must be able to assess if the machine is operating safely.

Configuration

You need suitable expertise and experience. You must be able to assess if the machine is operating safely.

Operation and maintenance

You need suitable expertise and experience. You must be instructed in machine operation by the machine operator. For maintenance, you must be able to assess if the machine is operating safely.

3 Product description

3.1 Structure and function

Overview

The deTec4 C4P-EAxxx3SC05 safety light curtain is an electro-sensitive protective device (ESPE) consisting of a sender and receiver.

A series of parallel infrared light beams forms a protective field between sender and receiver that protects the hazardous area (hazardous point, access, and hazardous area protection). When one or more beams are completely interrupted, the safety light curtain reports the interruption in the light path to the secure output signal switching devices (OSSDs) by a signal change. The machine or its control must safely analyze the signals (for example using a safe control or safety relays) and stop the dangerous state.

Sender and receiver automatically synchronize themselves optically. An electrical connection between both components is not required, but is advantageous.

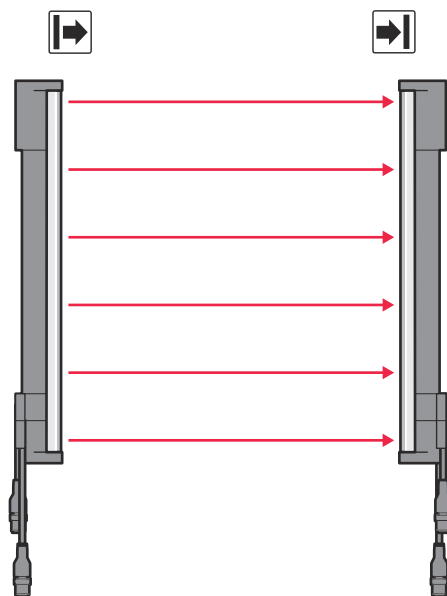

Figure 2: Sender and receiver

Protective field height

The protective field height indicates the range within which the test rod belonging to the safety light curtain is reliably detected.

Protective field width

The protective field width is the dimension of the light path between sender and receiver. The maximum protective field width is limited by the scanning range.

Resolution

The resolution describes the size of the smallest object detected by the safety light curtain in the protective field. The resolution corresponds to the diameter of the test rod belonging to the safety light curtain.

The safety light curtain has a resolution of 30 mm.

Scanning range

The scanning range is the maximum protective field width.

The scanning range is reduced by using deflector mirrors.

The scanning range is reduced by using a weld spark guard.

Further topics

- ["Flexible control cabinet cabling and status indication on both sides", page 17](#)
- ["Data sheet", page 81](#)
- ["Deflector mirrors", page 95](#)
- ["Weld spark guard", page 89](#)

3.2 Product characteristics

3.2.1 Device overview

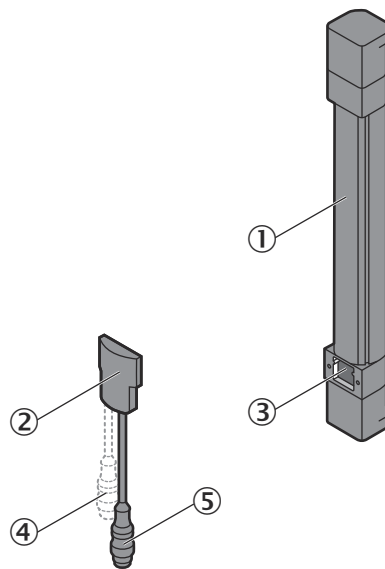

Figure 3: Device overview

- ①
- ②
- ③
- ④
- ⑤

3.2.2 Absence of blind zones

The design and construction of the safety light curtain extends the protective function of a device to the end of the housing without any blind spots. The absence of blind zones reduces the space requirement when integrated in the machine.

3.2.3 Automatic calibration of the protective field width

When switched on, the safety light curtain automatically calibrates to the protective field width.

3.2.4 Beam coding.

Depending on its configuration, the safety light curtain operates with 1 of 3 beam codings: uncoded, code 1 or code 2. The beam coding “uncoded” allows for particularly short response times. In order to avoid mutual interference between 2 neighboring safety light curtains, one can be operated with code 1 and the other with code 2.

3.2.5 Alignment aid

A laser alignment aid is installed in the sender of the safety light curtain. The laser alignment aid can be switched on to perform a simple alignment of the sender.

Diagnostic LEDs are installed in the receiver of the safety light curtain. For a simple alignment of the receiver, diagnostic LEDs 1, 2, 3 and 4 indicate the alignment quality once the safety light curtain has been switched on.

Diagnostic LEDs 5 and 6 light up if the topmost beam (far from system plug) is synchronized. Diagnostic LEDs 7 and 8 light up if the bottommost beam (near system plug) is synchronized.

3.2.6 Restart interlock

The safety light curtain has an integrated restart interlock. The function can be configured during commissioning.

A restart interlock prevents the machine from starting again once the protective device has been triggered. The operator must first press a reset pushbutton to allow the protective device to resume its monitoring function. The operator can then restart the machine.

The reset pushbutton can be connected locally to the extension connection or in the control cabinet.

3.2.7 External device monitoring (EDM)

The safety light curtain has integrated external device monitoring. The function can be configured during commissioning.

The external device monitoring (EDM) monitors the status of downstream contactors.

In order to use external device monitoring, positively guided contactors must be used to switch off the machine. If the auxiliary contacts of the positively guided contactors are connected to the external device monitoring, the external device monitoring checks whether the contactors switch correctly when the OSSDs are switched off.

3.2.8 Application diagnostic output

The safety light curtain has an application diagnostic output on the system connection and on the extension connection.

Depending on the configuration, the application diagnostic output signals a certain status of the safety light curtain, e.g. if the reset pushbutton must be engaged or if there is a weak signal at the receiver.

For a signal of the safety light curtain to be displayed, a light can be connected to the application diagnostic output or the signal can be transmitted to the machine controller.

The following signals can be output over the application diagnostic output:

- Reset required
- Weak signal

3.2.9 IO-Link

Overview

The safety light curtain can communicate with an IO-Link master via an IO-Link connector, which is available as an accessory.

The following information can be output via IO-link:

- Application diagnostic output status information
- Device information and device status
- Configuration of the device
- Status of each individual light beam
- Error history
- Reasons for the last lockout

The following information can be controlled via IO-link:

- LED signal behavior of the field indicator
- Switching on and off of the integrated laser alignment aid

Complementary information

The safety light curtain must be supplied with voltage to enable communication with an IO-Link master via the IO-Link connector.

Further topics

- ["Accessories", page 88](#)

3.2.10 Near Field Communication (NFC)

Overview

The receiver of the safety light curtain has an integrated NFC interface for transmitting diagnostic data of the protective device to an NFC-capable device.

The integrated NFC interface is intended for temporary use.

Diagnostic data

You can access the diagnostic data in any operational status of the protective device.

The following diagnostic data can be displayed in an NFC-capable device:

- Device-specific information of the protective device, e.g. name, serial number, type code
- Information on configuration, e.g. whether the restart interlock is activated
- Current status of the protective device, e.g. status of the OSSDs, quality of the alignment
- Error diagnostics with specification of the error code, error description, diagnostic LED and error correction

An NFC-capable antenna is integrated behind the front screen of the safety light curtain for transmitting the data. The area is marked with the NFC-symbol.



Figure 4: NFC symbol ¹⁾

To be able to call up information for diagnostics and configuration, you need an NFC-capable device, e.g. a smartphone and the SICK Safety Assistant app provided by SICK.

¹⁾ The N-Mark is a trademark or registered trademark of NFC Forum, Inc. in the United States and in other countries.

- ▶ Hold the NFC-capable mobile device near the marked NFC-area on the lower end of the receiver to call up the diagnostic data.

Complementary information

The SICK Safety Assistant App is available for devices with the following operating systems:

- Android
- iOS

3.2.11 System plug

Overview

The following system plugs are available for the safety light curtain:

- SP1 system plug

The system plugs are available in the following versions:

- System plug with 5-pin system connection
- System plug with 8-pin system connection
- System plug with 5-pin system connection and 5-pin extension connection
- System plug with 8-pin system connection and 5-pin extension connection

Functional scope





The following functions are available depending on the system plug used:

- Beam coding
- Restart interlock
- External device monitoring (EDM)
- Application diagnostic output
- IO-Link

The SP1 system plug can be used on all of the senders and receivers of a single system.

Using the system plugs

Table 3: Use of SP1 system plug in a single system

	SP1 system plug type code			
	1000 	1200 	1100 	1300 
Sender	✓	✓ ¹⁾	✓	✓ ¹⁾
Receiver	✓ <ul style="list-style-type: none"> • Beam coding 	✓ <ul style="list-style-type: none"> • Beam coding • Restart interlock • External device monitoring • Application diagnostic output 	✓ <ul style="list-style-type: none"> • Beam coding • Restart interlock • External device monitoring • Application diagnostic output • IO-Link 	✓ <ul style="list-style-type: none"> • Beam coding • Restart interlock • External device monitoring • Application diagnostic output • IO-Link

✓ SP1 system plug suitable.

¹⁾ At the sender, the 8-pin system connection is solely for the purposes of providing standardized wiring. It is particularly recommended if the 8-pin system connection at the receiver is used and the sender and receiver are connected to each other via a T-connector.

3.2.12 Flexible control cabinet cabling and status indication on both sides

The safety light curtain can be connected to the control cabinet in different ways as required:

- Separate connecting cables for sender and receiver
- Separate connecting cables for sender and receiver with connection in the control cabinet
- Connection of sender and receiver via a T-connector, shared 5-pin or 8-pin connecting cable to the control cabinet

The OSSD status and the status of the protective field are indicated via LEDs on the sender and receiver when the following applies:

- The sender and receiver are connected to one another in the control cabinet
- The sender and receiver are connected to one another via a T-connector

If the sender and receiver are not connected to each other, this status information is only indicated at the receiver.

In order to output status information to the sender via IO-Link, the sender and receiver must be connected with each other.

3.2.13 Status indicators

Overview

The sender and receiver LEDs indicate the operational status of the safety light curtain.

Sender displays

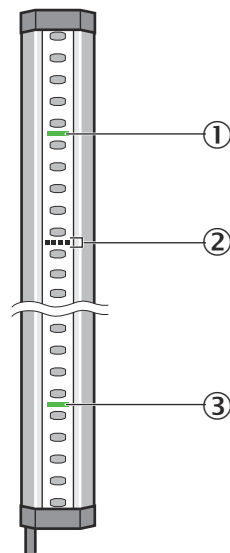

Figure 5: Sender displays

The sender has one laser alignment aid and at least two light emitting diodes, which indicate the operational status:

Position	LED color	Function	Labeling
①	Red/yellow/green	Field indicator ¹⁾ ; shows the status of the protective field and additional information about the status display	-
②	-	Laser alignment aid	-
③	Red/yellow/green	Status indicator	STATE

1) Safety light curtains with protective field height > 300 mm have multiple LEDs for the field indicator.

Receiver displays

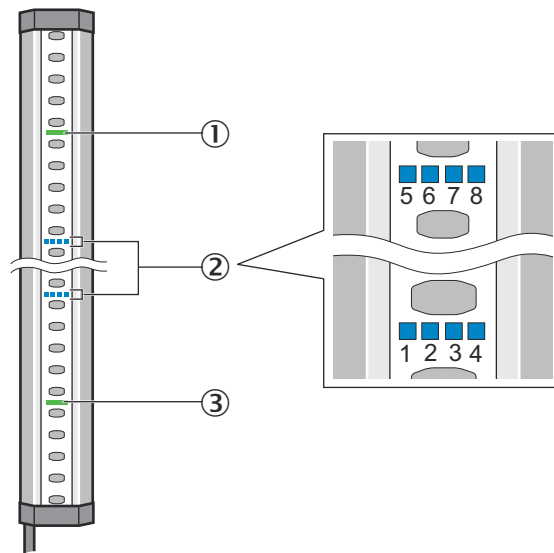

Figure 6: Receiver displays

At least ten light emitting diodes on the receiver indicate the operational status:

Position	LED color	Function	Labeling
①	Red/yellow/green	Field indicator ¹⁾ ; shows the status of the protective field and additional information about the status display	-
②	Blue/red/yellow/white	Diagnostics	1, 2, 3, 4, 5, 6, 7, 8
③	Red/green	OSSD status	OSSD

1) Safety light curtains with protective field height > 300 mm have multiple LEDs for the field indicator.



Further topics

- ["Diagnostic LEDs", page 72](#)

3.2.13.1 Indication of diagnostic LEDs

Table 4: Colors and their meaning

Color	Color	Meaning
●	White	Configuration status
●	Blue	Alignment quality

Color	Color	Meaning
	Red	Fault indicator
	Yellow	Warning

○ LED off.  LED flashes. ● LED illuminates.

Table 5: Indication of the configuration status

Diagnostic LEDs	Color	Configuration
1	● White	External device monitoring (EDM) is configured.
2	● White	Reserved
3	● White	Beam coding is configured.
4	● White	Restart interlock is configured.
5	● White	Reserved
6	● White	Reserved
7	● White	Reserved
8	● White	Reserved



○ LED off.  LED flashes. ● LED illuminates.

Table 6: Indication of the alignment quality

Diagnostic LEDs	Color	Meaning
1 ... 4	● Blue	Indication of the alignment quality. If only one diagnostic LED lights up, the alignment is insufficient. If all 4 diagnostic LEDs light up, the alignment is excellent.
5, 6	● Blue	The topmost beam (far from system plug) is synchronized.
7, 8	● Blue	The bottommost beam (near system plug) is synchronized.

○ LED off.  LED flashes. ● LED illuminates.

Table 7: Fault indicator

Diagnostic LEDs	Color	Meaning
1 ... 8	● Red	A red illuminated diagnostic LED signals the function at which an error has occurred.
1 ... 8	 Red	A red flashing diagnostic LED signals the reason for the error.

○ LED off.  LED flashes. ● LED illuminates.

Example: If diagnostic LED 1 lights up red and diagnostic LED 5 flashes red, there is an EDM error.

Table 8: Warnings

Diagnostics LED	Color	Meaning
1 ... 8	● Yellow	A yellow illuminated diagnostic LED signals which function is affected.
1 ... 8	 Yellow	A yellow flashing diagnostic LED signals the reason for the warning.

○ LED off.  LED flashes. ● LED illuminates.

Further topics

- ["Diagnostic LEDs", page 72](#)

3.3 Example applications

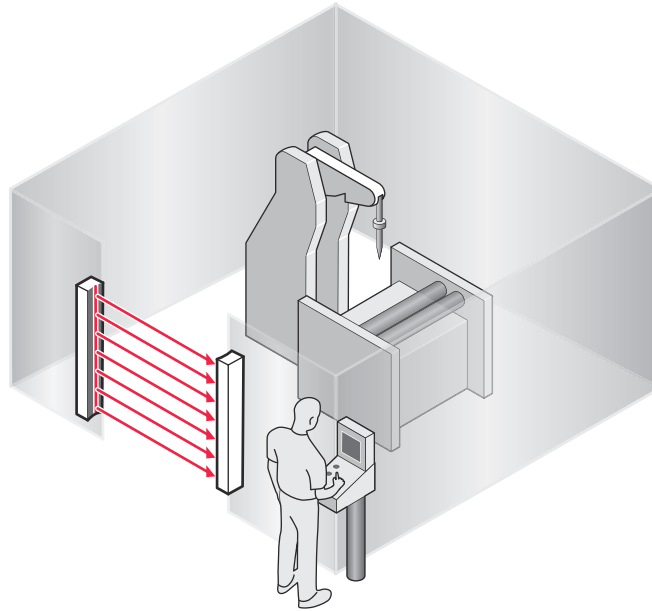

Figure 7: Access protection

4 Project planning

4.1 Manufacturer of the machine

The manufacturer of the machinery must carry out a risk assessment and apply appropriate protective measures. Further protective measures may be required in addition to the product.

The product must not be tampered with or changed, except for the procedures described in this document.

The product must only be repaired by the manufacturer of the product or by someone authorized by the manufacturer. Improper repair can result in the product not providing the expected protection.

4.2 Operating entity of the machine

Changes to the electrical integration of the product in the machine controller and changes to the mechanical mounting of the product necessitate a new risk assessment. The results of this risk assessment may require the entity operating the machine to meet the obligations of a manufacturer.

After each change to the configuration, it is necessary to check whether the protective measure provides the necessary protection. The person making the change is responsible for ensuring that the protection measure provides the necessary protection.

The product must not be tampered with or changed, except for the procedures described in this document.

The product must only be repaired by the manufacturer of the product or by someone authorized by the manufacturer. Improper repair can result in the product not providing the expected protection.

4.3 Design

Overview

This chapter contains important information about the design.

Important information



DANGER

Hazard due to lack of effectiveness of the protective device

Persons and parts of the body to be protected may not be recognized in case of non-observance.

- ▶ Make sure that the following construction requirements are met so that the safety light curtain can fulfill its protective function.
 - Sender and receiver must be arranged such that persons or parts of the body are reliably detected when they enter the hazardous area.
 - Reaching under, over, and around as well as moving the safety light curtain must be prevented.
 - Check whether additional safety measures (e.g. restart interlocking) are necessary when it is possible for people to be located between the protection system and the danger point without being detected.



DANGER

Hazard due to lack of effectiveness of the protective device

Certain types of light radiation can influence the protective device, e.g., light radiation from fluorescent lamps with electronic ballast installed in the path of the beam, or beams from laser pointers directed at the receiver.

- ▶ If this type of light radiation is present in the environment of the protective device, take additional measures to ensure that the protective device does not become dangerous.
-



DANGER

Hazard due to lack of effectiveness of the protective device

Persons and parts of the body to be protected may not be recognized in case of non-observance.

- ▶ Make sure that the optical properties of the front screens of the sender and receiver are not changed, e.g., by:
 - beading water, mist, frost, or ice formation. If applicable, remove films or other types of contamination, disconnect the voltage supply of the receiver and then switch it back on.
 - Scratches or damage. Replace the device whose front screen is scratched or damaged.
 - ▶ Make sure that all reflective surfaces and objects maintain a minimum distance from the protective field.
 - ▶ Make sure that no dispersive media (e.g., dust, fog, or smoke) are within the calculated minimum distance from the protective field.
-

Further topics

- ["Mounting", page 41](#)

4.3.1 Scanning range and protective field width

Important information



DANGER

Hazard due to lack of effectiveness of the protective device

Persons and parts of the body to be protected may not be recognized in case of non-observance.

- ▶ The safety light curtain can only be mounted to machines on which the protective field width does not change when the safety light curtain is switched on.
-

Protective field width

The protective field width is the dimension of the light path between sender and receiver. The maximum protective field width is limited by the scanning range.

The protective field width is automatically calibrated when the safety light curtain is switched on during initialization and must not be changed during operation.

Scanning range

The scanning range limits the maximum protective field width. The protective field width cannot change during operation.

The scanning range is reduced by using deflector mirrors.

The scanning range is reduced by using a weld spark guard.

Further topics

- ["Minimum distance to reflective surfaces", page 25](#)
- ["Technical data", page 81](#)
- ["Deflector mirrors", page 95](#)
- ["Weld spark guard", page 89](#)

4.3.2 Minimum distance from the hazardous point**Overview**

A minimum distance must be maintained between the safety light curtain and the hazardous point. This distance is required to prevent a person or part of their body from reaching the hazardous point before the end of the machine's dangerous state.

Calculation of the minimum distance according to ISO 13855

The calculation of the minimum distance is based on international or national standards and statutory requirements applicable at the place of installation of the machine.

If the minimum distance is calculated according to ISO 13855, then it depends on the following points:

- Machine stopping time (time interval between triggering the sensor function and the end of the machine's dangerous state)
- Response time of the protective device
- Reach or approach speed of the person
- Resolution (detection capability) of the safety light curtain
- Type of approach: orthogonal (at right angles) or parallel
- Parameters specified based on the application

For the USA (scope of OSHA and ANSI), different regulations may apply, e.g.:

- Laws: Code of Federal Regulations, Title 29 (CFR 29), Part 1910.217
- Standards: ANSI B11.19

Complementary information

More information is available in the ISO 13855 standard and in the Guide for Safe Machinery.

SICK offers a stopping/run-down time measurement service in many countries.

Further topics

- ["Response time", page 84](#)

4.3.2.1 Calculating minimum distance from the hazardous point**Important information****DANGER**

Minimum distance from the hazardous point is too small

The dangerous state of the machine may not be stopped or not be stopped in a timely manner due to a minimum distance that is too small.

- ▶ Calculate the minimum distances for the machine in which the safety light curtain is integrated.
- ▶ When mounting the safety light curtain, observe the minimum distance.

Approach

The example shows the calculation of the minimum distance in accordance with ISO 13855 for an orthogonal (right-angled) approach to the protective field. A different calculation may be required depending on the application and the ambient conditions (e.g., for a protective field parallel to or at any angle to the direction of approach or an indirect approach).

1. First, calculate S using the following formula:

$$S = (K \times T) + 8 \times (d - 14 \text{ mm})$$
 Where:
 - S = minimum distance in millimeters (mm)
 - K = approach speed (stepping and/or gripping speed) of a person or a body part (mm/s), e.g. 2,000 mm/s
 - T = machine stopping time + response time of the protective device after interruption in the light path in seconds (s)
 - d = resolution of the safety light curtain in millimeters (mm)
2. If the result S is ≤ 500 mm, then use the determined value as the minimum distance.
3. If the result S is > 500 mm, then recalculate S with an approach speed of 1,600 mm/s as follows:

$$S = 1,600 \text{ mm/s} \times T + 8 \times (d - 14 \text{ mm})$$
4. If the new value S is > 500 mm, then use the newly determined value as the minimum distance.
5. If the new value S is ≤ 500 mm, then use 500 mm.

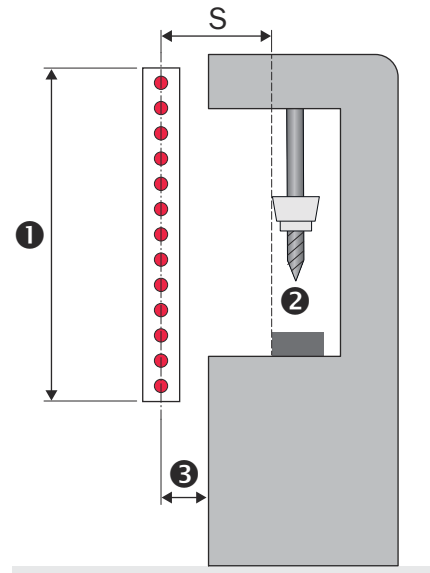

Figure 8: Minimum distance to the hazardous point for orthogonal (rectangular) approach to the protective field

- ① Protective field height
- ② Hazardous point
- ③ Depending on the application and distance, persons must be prevented from standing behind the protective device.

Example calculation

Machine stopping time = 290 ms

Response time after interruption of the light path = 30 ms

Resolution of the safety light curtain = 30 mm

$$T = 290 \text{ ms} + 30 \text{ ms} = 320 \text{ ms} = 0.32 \text{ s}$$

$$S = 2,000 \text{ mm/s} \times 0.32 \text{ s} + 8 \times (30 \text{ mm} - 14 \text{ mm}) = 768 \text{ mm}$$

$S > 500 \text{ mm}$, therefore:

$$S = 1,600 \text{ mm/s} \times 0.32 \text{ s} + 8 \times (30 \text{ mm} - 14 \text{ mm}) = 640 \text{ mm}$$

4.3.2.2 Taking reach over into account

In accordance with ISO 13855, it must not be possible to defeat the ESPE. If access to the hazardous area by reaching over a protective field cannot be prevented, the height of the protective field and minimum distance of the ESPE must be determined. This is done by comparing the calculated values based on the possible detection of limbs or body parts with the values resulting from reaching over the protective field. The greater value resulting from this comparison must be used.

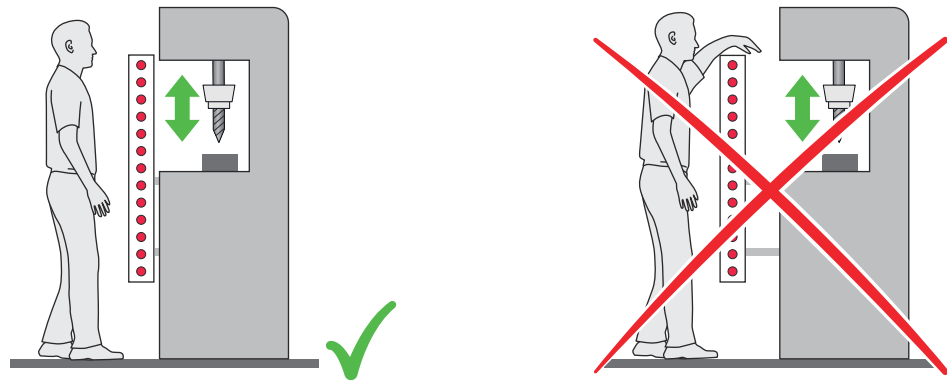

Figure 9: Representation of the accessibility of ESPE by reaching over. Left: Protective field that cannot be reached over. Right: Protective field that can be reached over.

4.3.3 Minimum distance to reflective surfaces

Overview

The light beams from the sender may be deflected by reflective surfaces and dispersive media. This may prevent an object from being detected.

Therefore, all reflective surfaces and objects (e.g. material bins, machine table, etc.) must maintain a minimum distance (a) from the protective field. This minimum distance (a) must be maintained on all sides of the protective field. This applies in horizontal, vertical and diagonal directions as well as at the end of the safety light curtain. The same area must be free of dispersive media (e.g., dust, fog, or smoke).

The minimum distance (a) depends on the distance (D) between sender and receiver (protective field width).

The weld spark guard can influence the optical properties of the safety light curtain, meaning that reflective surfaces have to observe a larger minimum distance.

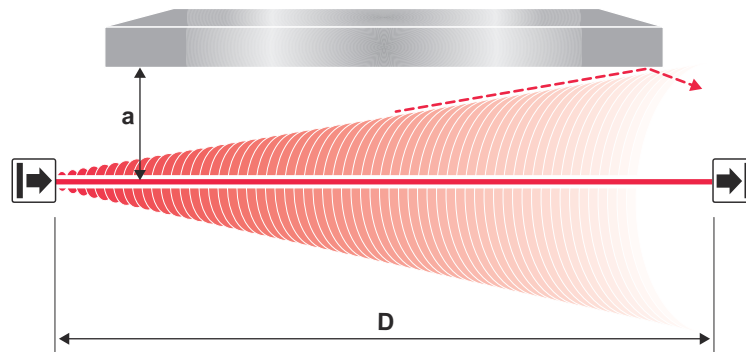

Figure 10: Minimum distance from reflective surfaces

Important information



DANGER

Hazard due to lack of effectiveness of the protective device

Reflective surfaces and dispersive media can prevent persons or parts of the body to be protected from being properly reflected and, therefore, remain undetected.

- ▶ Make sure that all reflective surfaces and objects maintain a minimum distance from the protective field.
- ▶ Make sure that no dispersive media (e.g., dust, fog, or smoke) are within the calculated minimum distance from the protective field.

Determining minimum distance from reflective surfaces with automated calibration of the protective field width

The minimum distance can be determined as follows:

- ▶ Determine the distance between sender and receiver D in meters (m).
- ▶ Read the minimum distance a in millimeters (mm) in the graph or calculate using the respective formula to determine the minimum distance to reflective surfaces:

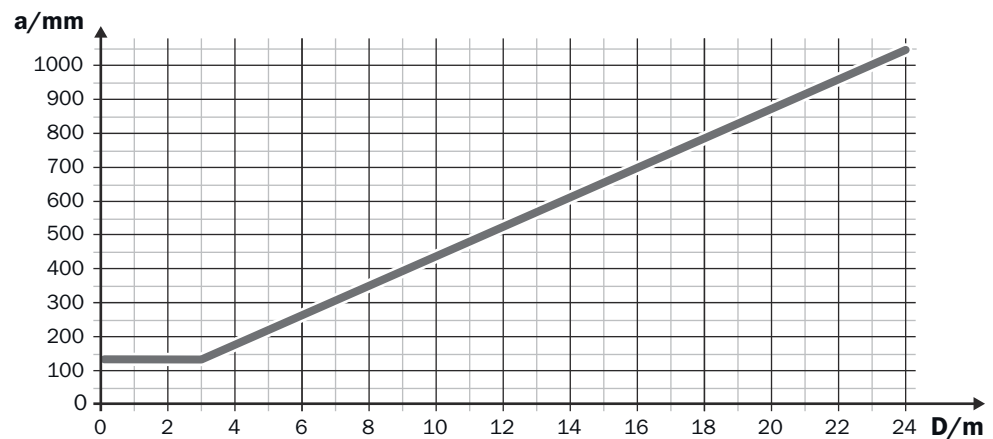

Figure 11: Graph of minimum distance from reflective surfaces

Table 9: Formula for calculating the minimum distance to reflective surfaces with automatic calibration of the protective field width

Distance D between sender and receiver in m	Calculation of the minimum distance (a) to reflective surfaces in mm
$D \leq 3 \text{ m}$	$a = 131 \text{ mm}$
$D > 3 \text{ m}$	$a = \tan(2.5^\circ) \times 1,000 \text{ mm/m} \times D = 43.66 \times 1 \text{ mm/m} \times D$

Further topics

- "Weld spark guard", page 89

4.3.4 Protection against interference from systems in close proximity to each other**Overview**

Figure 12: Preventing mutual interference from system ① and system ②

The infrared light beams of the sender of system ① can interfere with the receiver of system ②. This can disrupt the protective function of system ②. This would mean that the operator is at risk.

Important information**DANGER**

Hazard due to lack of effectiveness of the protective device

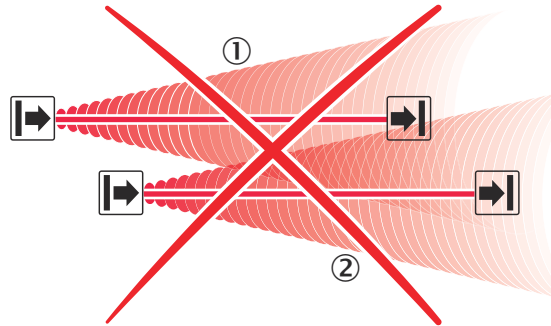
The integrated laser alignment aid may influence the receiver of a safety light curtain in close proximity. In such cases, the neighboring safety light curtain may not detect persons or parts of the body that require protection.

- ▶ Perform an alignment or take other measures to ensure that the laser beam only hits the front screen of the relevant receiver. The laser beam must not hit any external receiver should the integrated laser alignment aid be switched on by mistake or due to a fault. An external receiver is a receiver that is not part of the same safety light curtain.
- ▶ During alignment in particular, make sure that the laser beam does not hit any external receiver.

**DANGER**

Hazard due to lack of effectiveness of the protective device

Systems of safety light curtains in close proximity to each other can mutually interfere with each other.

- ▶ Use appropriate measures to prevent systems in close proximity from interfering with each other.

Preventing interference between systems in close proximity to each other

The following measures prevent interference from systems in close proximity:

- Different beam coding for neighboring systems
- Reversed direction of transmission for neighboring systems
- Optically opaque partitions

Further topics

- ["Using beam coding", page 28](#)
- ["Using reversed direction of transmission", page 29](#)

4.3.4.1 Using beam coding

Important information



DANGER

Hazard due to lack of effectiveness of the protective device

Different beam codings only prevent mutual interference if both safety light curtains are of type deTec4 C4P-EAxxx3SC05.

- ▶ In the case of systems in close proximity that are of a different type, take different measures to prevent mutual interference.



DANGER

Hazard due to lack of effectiveness of the protective device

A safety light curtain with the beam coding "uncoded" can be affected by senders with code 1 or code 2.

A safety light curtain with code 1 or code 2 can be affected by senders with the beam coding "uncoded".

Safety light curtains with the same beam coding can interfere with each other.

- ▶ If systems are in close proximity to each other, only use code 1 and code 2.

Using beam coding

Use suitable beam codings to prevent mutual interference from neighboring systems.

- ▶ Configure one safety light curtain with code 1 and the other safety light curtain with code 2.

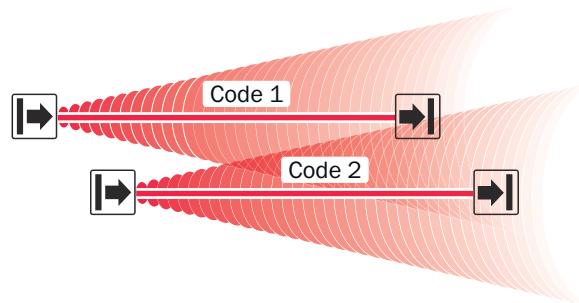

Figure 13: Trouble-free operation due to beam coding

In the figure, the beam coding of systems in close proximity to each other is different. The system with code 2 is not affected by the beams of the system with code 1.

Further topics

- ["Configuring beam coding", page 57](#)
- ["Combining beam coding and reversed direction of transmission", page 29](#)

4.3.4.2 Using reversed direction of transmission

Important information



NOTE

The direction of transmission of the system can be changed during installation by switching the positions of the sender and receiver. The sender and receiver are easy to exchange with each other if they are wired in the same way.

Using reversed direction of transmission

The direction of transmission of the system ② can be changed during mounting by switching the positions of the sender and receiver. With reversed direction of mounting, the receiver ② is not affected by the infrared light from the sender ①.

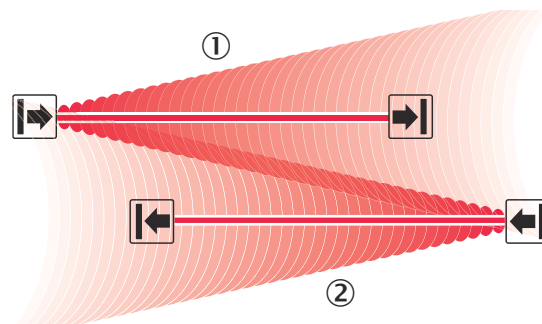

Figure 14: Trouble-free operation due to reversed direction of transmission of system ① and system ②

Further topics

- ["Connection of sender and receiver", page 34](#)
- ["Combining beam coding and reversed direction of transmission", page 29](#)

4.3.4.3 Combining beam coding and reversed direction of transmission

To prevent a mutual interference in the case of more than two neighboring systems, beam coding and reversed direction of transmission can be combined.

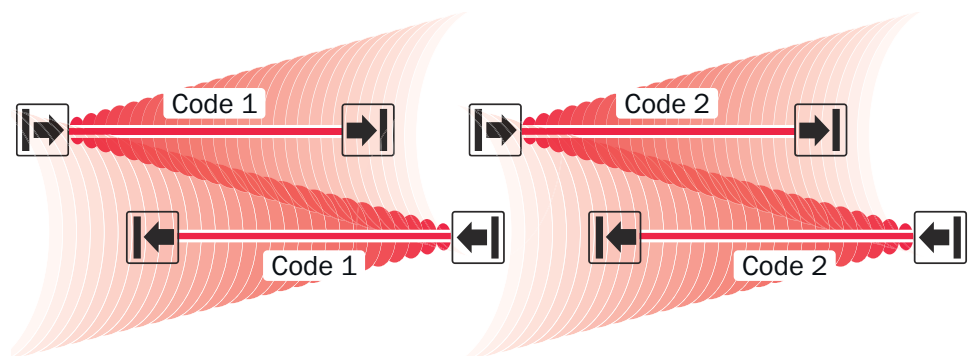

Figure 15: Trouble-free operation of 4 neighboring systems due to beam coding and reversed direction of transmission

In the figure, the beam coding of the systems arranged next to each other is different. The direction of transmission of the systems arranged on top of each other is reversed. This prevents the systems from interfering with each other.

4.4 Integration in electrical control

Overview

This chapter contains important information about integration in the electrical control. Information about the individual steps for electrical installation of the device: see ["Electrical installation", page 51.](#)

Important information



DANGER

Hazard due to lack of effectiveness of the protective device

In the case of non-compliance, it is possible that the dangerous state of the machine may not be stopped or not stopped in a timely manner.

- Make sure that the following control and electrical requirements are met so that the product can fulfill its protective function.

Requirements for use

The output signals of the protective device must be analyzed by downstream controllers in such a way that the dangerous state of the machine is ended safely. Depending on the safety concept, signal evaluation is carried out e.g. with safety relays or with a safety controller.

- It must be possible to electrically influence the control of the machine
- The electrical control of the machine must meet the requirements of IEC 60204-1
- When using a safety controller, different signal levels of both OSSDs must be detected depending on applicable national regulations or required reliability of the safety function. The maximum discrepancy time tolerated by the controller must be selected according to the application.
- The OSSD1 and OSSD2 output signals must not be connected to each other
- In the machine controller, the signals of both OSSDs must be processed separately

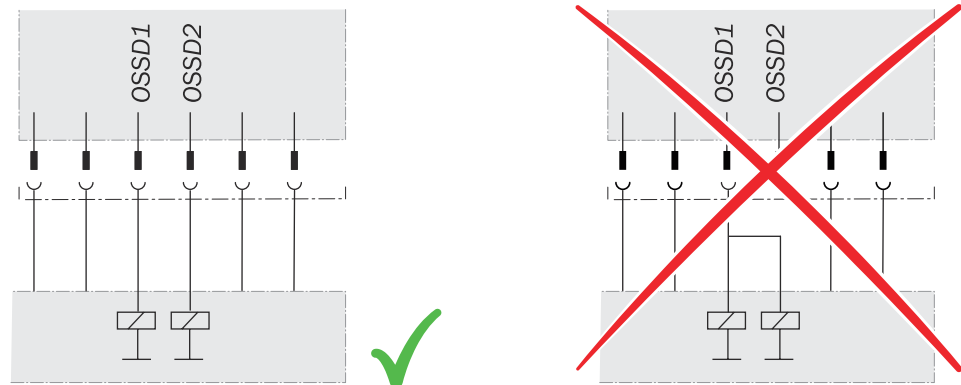

Figure 16: Dual-channel and isolated connection of OSSD1 and OSSD2

- The machine must switch to the safe state at any time if at least one of the two OSSDs switches to the OFF state
- Prevent the formation of a potential difference between the load and the protective device. If you connect loads to the OSSDs (switch outputs) that then also switch if controlled with negative voltage (e.g., electro-mechanical contactor without reverse polarity protection diode), you must connect the 0 V connections of these loads and those of the corresponding protective device individually and directly to the same 0 V terminal strip. In the event of a fault, this is the only way to ensure that there can be no potential difference between the 0 V connections of the loads and those of the corresponding protective device.

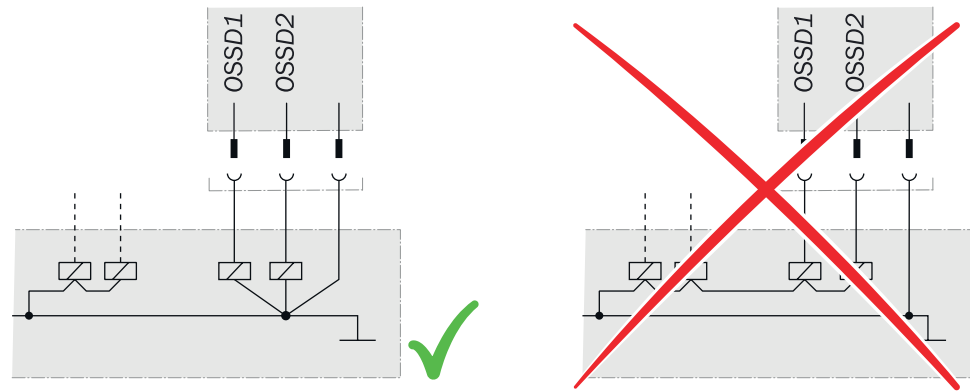

Figure 17: No potential difference between load and protective device



DANGER

Hazard due to lack of effectiveness of the protective device

In the case of non-compliance, it is possible that the dangerous state of the machine may not be stopped or not stopped in a timely manner.

Downstream contactors must be positively guided and monitored depending on applicable national regulations or required reliability of the safety function.

- ▶ Make sure that downstream contactors are monitored (external device monitoring, EDM).



DANGER

Hazard due to unexpected starting of the machine

A restart interlock must be implemented depending on applicable national regulations or required reliability of the safety function.

- ▶ Make sure that a restart interlock is implemented.

Requirements for the electrical control of the machine

Both outputs are short-circuit protected to 24 V DC and 0 V. When the protective field is clear, the OSSDs are in the ON state. When a switch-off condition is present (e.g., interruption in the light path), the OSSDs are in the OFF state. In the event of a device fault, at least one OSSD is in the OFF state.

The protective device complies with the rules for electromagnetic compatibility (EMC) for the industrial sector (Radio Safety Class A).



NOTE

Using the device in residential areas may cause radio interference. The operating entity is responsible for taking appropriate measures (e.g., shielding).

The following requirements are met:

- The external voltage supply of the protective device must be capable of buffering brief power failures of 20 ms as specified in IEC 60204-1.
- The power supply unit must ensure safe isolation according to IEC 61140 (SELV/PELV). Suitable power supply units are available as accessories from SICK.

Further topics

- ["Accessories", page 88](#)

4.4.1 Restart interlock

Overview

The restart interlock prevents the machine from automatically starting up, for example after a protective device has responded while the machine is operating or after changing the machine's operating mode.

Depending on the regulations which apply at the place of installation, a restart interlock may be required.

The safety light curtain has an internal restart interlock.

Important information



DANGER

Hazard due to unexpected starting of the machine

The machine may not restart if the OSSDs switch to the ON state once the reset pushbutton has been pressed. The control must ensure that the machine only restarts if the machine start button is also pressed after the reset pushbutton.

- Make sure that the machine can only restart once the reset pushbutton and start button have been pressed in the specified order.

Principle of operation

Before the machine can be restarted, the operator must reset the restart interlock.

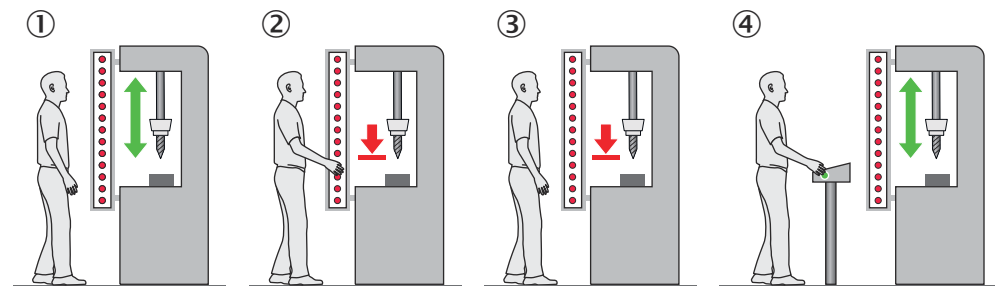

Figure 18: Schematic representation of operation with restart interlock

The dangerous state of the machine (①) is brought to an end if the light path is interrupted (②) and is not re-enabled (③) until the operator presses the reset pushbutton located outside the hazardous area (④). The machine can then be restarted.

Depending on applicable national regulations, a restart interlock must be available if it is possible to stand behind the protective device. Observe IEC 60204-1.

4.4.1.1 Integrated restart interlock and reset

Prerequisites

- A reset device, such as a reset pushbutton, is connected.

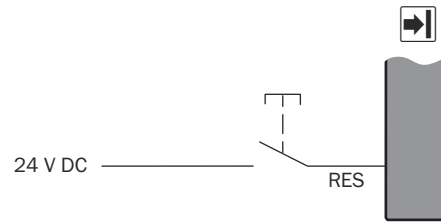

Figure 19: Electrical diagram of the reset device

Using an integrated restart interlock

The restart interlock is configured once the reset pushbutton has been connected.

When the restart interlock is configured, the application diagnostic output located on the same plug connector as the reset pushbutton signals when the reset pushbutton needs to be pressed.

The following applies to the restart interlock:

- If the protective field is clear once the machine has been switched on or following an interruption, the OSSDs do not switch to the ON state
- If someone presses the reset pushbutton and then lets go of it when the protective field is clear, the OSSDs switch to the ON state
- The machine may not restart yet. The operator must also press the machine start button after having pressed the reset pushbutton.

Single system

Only one reset pushbutton may be connected to a single safety light curtain.

Connection options of the reset pushbutton in the single system:

- M12, 8-pin system connection
- Extension connection on the receiver

Further topics

- ["Configuring the restart interlock", page 58](#)

4.4.2 External device monitoring (EDM)

Overview

The safety light curtain has internal external device monitoring.

The external switching elements (external device monitoring, EDM) must be inspected in line with the regulations which apply at the place of installation or the required reliability of the safety function.

External device monitoring (EDM) monitors the status of downstream contactors.

Prerequisites

- Positively guided contactors are used for shutting down the machine.

Principle of operation

If you configure external device monitoring, the safety light curtain then checks the contactors after every interruption to the light path and before the machine restarts. External device monitoring is then able to detect if one of the contactor's contacts is welded, for instance. In this case, the OSSDs remain in the OFF state.

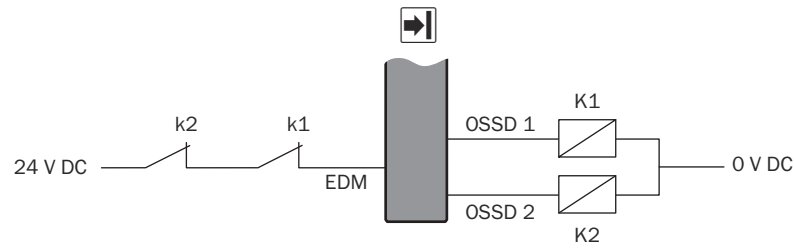

Figure 20: Electrical diagram of external device monitoring (EDM)

You must implement external device monitoring electrically so that the two N/Cs (k1, k2) close in a positively guided manner when the contactors (K1, K2) reach their de-energized position once the protective device has responded. 24 V are then present at the input of external device monitoring. If 24 V are not present once the protective device has responded, one of the contactors is defective and external device monitoring prevents the machine from restarting.

4.4.3 Application diagnostic output

The safety light curtain has an application diagnostic output on the system connection and on the extension connection.

Depending on the configuration, the application diagnostic output signals a certain status of the safety light curtain, e.g. if the reset pushbutton must be engaged or if there is a weak signal at the receiver.

For a signal of the safety light curtain to be displayed, a light can be connected to the application diagnostic output or the signal can be transmitted to the machine controller.

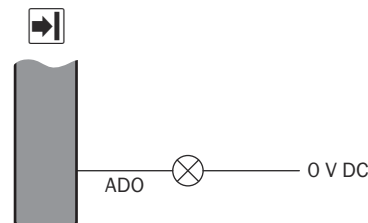

Figure 21: Electrical diagram of the application diagnostic output

Further topics

- ["Configuring application diagnostic output", page 59](#)

4.4.4 Connection of sender and receiver

Overview

For a status display on both sides, you can connect the sender and receiver in the control cabinet or via a T-connector.

The following information can be output:

- Status of the protective field from the sender and receiver
- Status indicator on the sender and receiver, e.g. whether muting is active
- Diagnostic data on the sender and receiver via NFC or IO-Link.

If the sender and receiver are not connected to each other, this status information is only indicated at the receiver.

Prerequisites

- The type codes of the sender and receiver must be identical at the following place in the number sequence.
 - Variant 1: C4P.*****0***
 - Variant 2: C4P.*****1***
- If the type codes at this place in the number sequence differ, the connection between the sender and receiver must be disconnected.

Connecting the sender and receiver

Connect the following wires with each other in the control cabinet:

- 0 V DC of sender and receiver
- +24 V DC of sender and receiver
- MFP1 of sender and receiver

Alternatively, you can connect the sender and receiver to each other via a T-connector (with an optional pushbutton for the laser alignment aid). In such cases, you only require a cable to the control cabinet and the status will also be indicated on both sides. Please note that the sender and receiver are protected jointly by one fuse when a T-connector is used. In the T-connector, all contacts are routed from the female connector to the same pins of both male connectors.

The T-connector must only be connected to the system connection of an individual device.

Even if you do not use a T-connector, you can connect the sender and receiver with identical cables. The advantage of this is that the sender and receiver can be switched without changing the cables if the installation situation so requires, e.g., to prevent mutual interference between systems in close proximity to each other.

Further topics

- ["Accessories", page 88](#)
- ["Protection against interference from systems in close proximity to each other", page 27](#)

4.4.5 Laser alignment aid**Important information****DANGER**

Hazard due to lack of effectiveness of the protective device

The integrated laser alignment aid switches the OSSDs to the OFF state.

- ▶ Make sure that the outputs of the safety light curtain do not have any effect on the machine when the integrated laser alignment aid is activated.
- ▶ Only use the integrated laser alignment aid to align the safety light curtain.

Prerequisites

- A pushbutton is connected.
- A T-connector with pushbutton is connected.
- A switch is connected.

Pushbutton

The pushbutton is mounted at the system connection of the sender between the system plug and the connecting cable.

The pushbutton can be temporarily mounted for alignments or used to maintain a permanent connection.

Functionality of the pushbutton

- Press the pushbutton once and release: integrated laser alignment aid is switched on
- Press the pushbutton again and release: integrated laser alignment aid is switched off

Switch

The switch is not suitable for safety light curtains where the sender and receiver are connected via a T-connector.

The switch is mounted in the control cabinet. A relay or a PLC can also be used as a switch to enable the integrated laser alignment aid to be switched on and off via a control panel, for example.

The switch must be connected in accordance with the circuit diagram below.

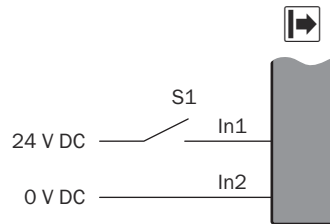

Figure 22: Switch for the integrated laser alignment aid

- S1 closed: integrated laser alignment aid is switched on
- S1 open: integrated laser alignment aid is switched off

IO-Link

If the sender and receiver are connected with each other, the laser alignment aid can also be activated by a command from IO-Link.

Further topics

- ["Connection of sender and receiver", page 34](#)
- ["IO-Link", page 36](#)
- ["Accessories", page 88](#)

4.4.6 IO-Link

Overview

The IO-Link connector is used to establish a connection between suitable devices and an IO-Link master, enabling communication via IO-Link.

The following information can be output via IO-link:

- Application diagnostic output status information
- Device information and device status
- Configuration of the device
- Status of each individual light beam
- Error history
- Reasons for the last lockout

The following information can be controlled via IO-link:

- LED signal behavior of the field indicator
- Switching on and off of the integrated laser alignment aid

Complementary information

Detailed information on how the IO-Link connector is connected can be found in the assembly instructions for the IO-Link connector.

4.5 Testing plan

The manufacturer of the machine and the operating entity must define all required checks. The definition must be based on the application conditions and the risk assessment and must be documented in a traceable manner.

In addition, the device must be checked for correct functioning after each change to the configuration and each insertion of the system plug.

- ▶ When defining the check, please note the following:
 - Define the type and execution of the check.
 - Define the frequency of the check.
 - Notify the machine operators of the check and instruct them accordingly.

The following checks are often defined in connection with a protective device:

- Check during commissioning and modifications
- Regular thorough check

Check during commissioning and modifications

Before commissioning the machine and after making changes, you must check whether the safety functions are fulfilling their planned purpose and whether persons are being adequately protected.

The following points are often helpful for the definition of the check:

- Does the check have to be completed by qualified safety personnel?
 - Can the check be completed by specially qualified and authorized personnel?
 - Does the check have to be documented in a traceable manner?
 - Can the check be carried out according to a check list? (see ["Checklist for initial commissioning and commissioning"](#), page 99)
 - Do the machine operators know the function of the protective device?
 - Have the machine operators been trained to work on the machine?
 - Have the machine operators been notified about modifications on the machine?
 - Does the hazardous area being secured have to be checked with a test rod? (see ["Test rod check"](#), page 37)
- ▶ Define all guidelines for the check.

Regular thorough check

The thorough check is intended to ensure that the safety functions are fulfilling their planned purpose and whether persons are being adequately protected.

The following points are often helpful for the definition of the check:

- Which check must be carried out and how is it carried out?
 - [Test rod check, page 37](#)
 - [Visual check of the machine and the protective device, page 40](#)
 - How often does the check have to be carried out?
 - Do the machine operators have to be notified of the check and do they need to be instructed accordingly?
- ▶ Define all guidelines for the check.

4.5.1 Test rod check

Overview

The rod test check is used to check whether the hazardous point is only accessible via the protective field of the safety light curtain and whether the protective device is able to identify each time the hazardous point is approached.

The test is carried out with an opaque test rod whose diameter corresponds to the resolution of the safety light curtain.

Important information



DANGER

Use of incorrect test rods

Persons or parts of the body to be protected may not be detected in operation.

- ▶ Only use the included test rod with the diameter specified on the type label of the safety light curtain.
 - ▶ Do not use any test rods with a similar or the same diameter of other safety light curtains.
-



DANGER

Hazard due to unexpected starting of the machine

- ▶ Make sure that the dangerous state of the machine is and remains switched off during the check.
 - ▶ Make sure that the outputs of the safety light curtain have no effect on the machine during the check of the components.
-



DANGER

Hazard due to lack of effectiveness of the protective device

Persons and parts of the body to be protected may not be recognized in case of non-observance.

Do not operate the machine if the field indicator lights up green or yellow during the check!

- ▶ If the field indicator lights up green or yellow during the check (even if only briefly) work must stop at the machine.
 - ▶ In this case, the mounting and electrical installation of the safety light curtain must be checked by qualified safety personnel.
-



NOTE

The integrated laser alignment aid switches the OSSDs to the OFF status.

- ▶ Ensure that the integrated laser alignment aid is switched off during the check.
-

Prerequisites

- The field indicator lights up green or flashes yellow.
The field indicator only flashes yellow if the internal restart interlock is configured and a reset is required.

Approach

1. Move the test rod slowly through the area to be protected (e.g., machine opening), as indicated by the arrow, [see figure 23](#).
2. Watch the field indicator on the receiver during the check. The field indicator on the receiver must continuously light up red. The field indicator must not light up green or flash yellow.

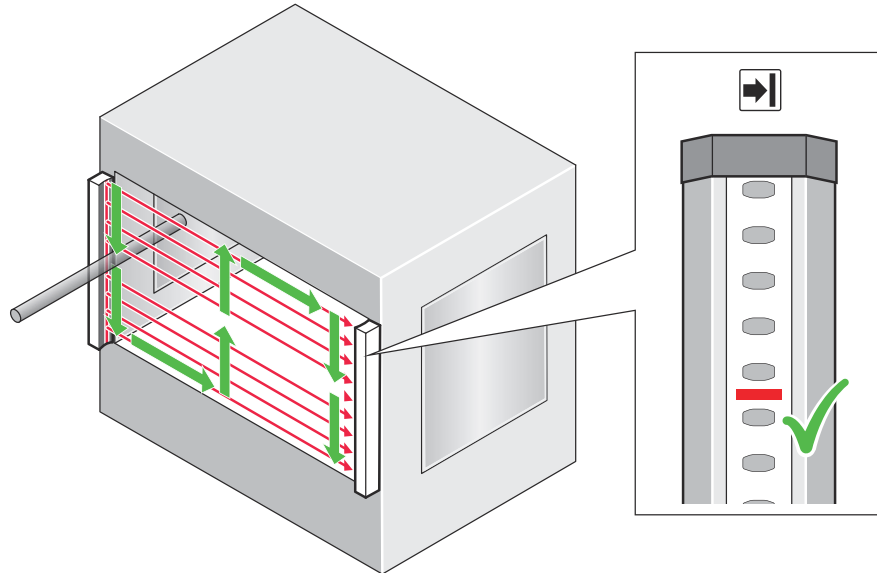

Figure 23: Test rod check: Step 1

3. Then, guide the test rod along the edges of the area to be protected, as indicated by the arrow, [see figure 24](#).
4. Watch the field indicator on the receiver during the check. The field indicator on the receiver must continuously light up red. The field indicator must not light up green or flash yellow.

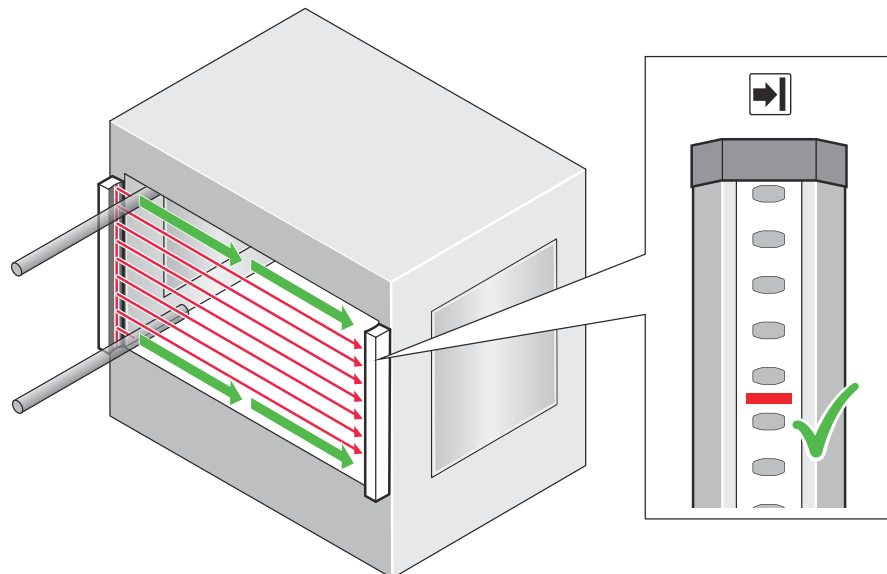

Figure 24: Test rod check: Step 3

5. If one or more deflector mirrors are used, then the test rod should also be guided slowly through the area to be protected directly in front of the deflector mirrors.
6. Watch the field indicator on the receiver during the check. The field indicator on the receiver must continuously light up red. The field indicator must not light up green or flash yellow.
7. After the test rod has been removed from the protective field, make sure that the protective field is clear and the field indicator is green or yellow.

4.5.2 Visual check of the machine and the protective device

The following points are often helpful for the definition of the check:

- Has the machine been retrofitted?
- Have machine parts been removed?
- Have modifications been made to the surroundings of the machine?
- Have the protective device or its parts been dismantled?
- Is it possible to enter the hazardous area without being detected?
- Is the protective device damaged?
- Is the protective device severely contaminated?
- Is the front screen contaminated, scratched or destroyed?
- Are there any damaged cables or open cable ends?
- Is the configuration of the protective device still the same?

If one of the points applies, the machine should be shut down immediately. In this case, the machine and the protective device must be checked by appropriately qualified safety personnel.

5 Mounting

5.1 Unpacking

Approach

1. Check the components for completeness and the integrity of all parts.
2. In the event of complaints, contact the responsible SICK subsidiary.

Further topics

- ["Ordering information", page 87](#)

5.2 Mounting the system plug

Overview

You must mount the system plug on the safety light curtain prior to starting mounting and electrical installation work. Please note that depending on the application, the system plug used at the sender may be different to that at the receiver.

Important information



DANGER

Hazard due to lack of effectiveness of the protective device

Malfunctions can occur if the safety light curtain is connected other than with one of the system plugs provided.

- ▶ Use the system plugs provided.



NOTICE

Fitting the system plug

If the system plug is not fitted, electrostatic discharge at the contacts may damage the device.

- ▶ Prevent electrostatic discharge at the contacts.



NOTICE

Enclosure ratings IP 65 and IP67 only apply if the front connector is fitted.

If the system plug is not mounted, dirt, dust, or moisture may enter the device and cause damage.

- ▶ Fitting the system plug.
- ▶ Prevent the entry of dirt, dust, and moisture.

Approach

1. Make sure that the safety light curtain and system plug are disconnected from the voltage supply while the system plug is being mounted.
2. Unpack the system plug.
3. Adjust the DIP switches as necessary.
4. Remove the protective film from the terminal compartment of the safety light curtain.
5. Carefully mount the system plug on the terminal compartment of the safety light curtain.
6. Use the 2 captive screws to screw the system plug onto the safety light curtain. Torque 0.5 Nm ± 0.1 Nm.

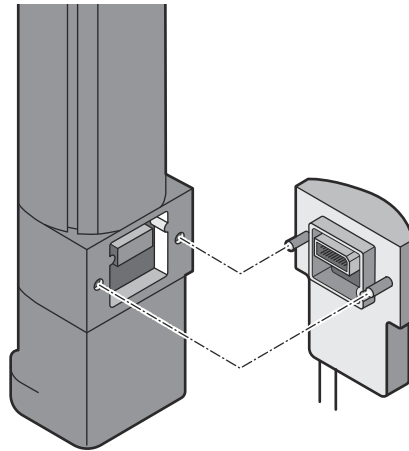

Figure 25: Mounting the system plug

5.3 Installation

Important information



DANGER

Hazard due to lack of effectiveness of the protective device

Persons or parts of the body to be protected may not be recognized or not recognized in time in case of non-observance.

- ▶ Observe the calculated minimum distances for the machine in which the safety light curtain is integrated.
 - ▶ Then, mount the safety light curtain such that it is not possible to reach over, under or around, or to stand behind the safety light curtain, and that the light curtain cannot be repositioned.
-



DANGER

Hazard due to lack of effectiveness of the protective device

Persons and parts of the body to be protected may not be recognized in case of non-observance.

- ▶ The safety light curtain can only be mounted to machines on which the protective field width does not change when the safety light curtain is switched on.
-



DANGER

Hazard due to lack of effectiveness of the protective device

Persons and parts of the body to be protected may not be recognized in case of non-observance.

- ▶ The end with the cable connection must point in the same direction for the sender and receiver.
-

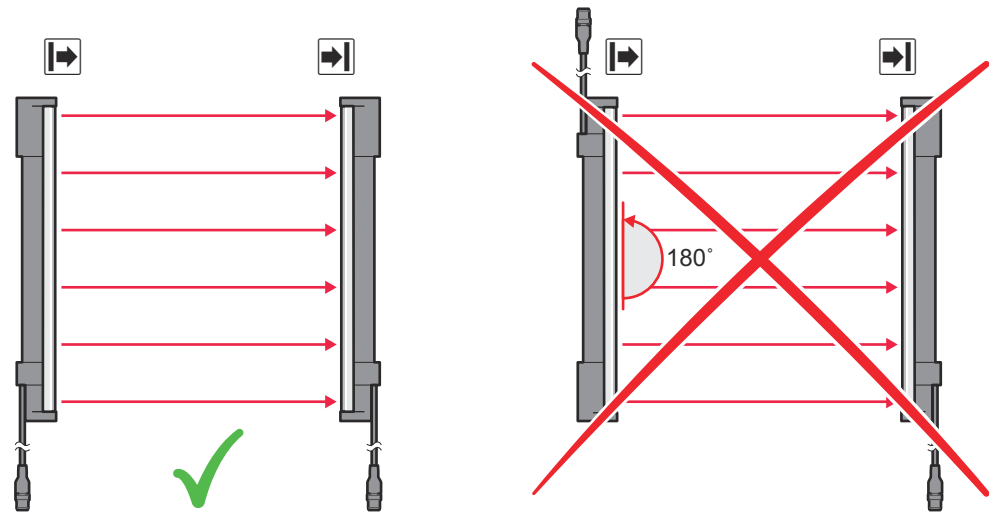

Figure 26: Sender and receiver must not be installed such that they are rotated 180° relative to each other

Prerequisites

- Project planning is completed.
- Assembly is carried out according to the project planning.
- Dangerous condition of the machine is and remains switched off during mounting.
- The outputs of the device do not affect the machine during mounting.
- Only use SICK-approved brackets for mounting.
- Take appropriate measures for vibration damping if vibration and shock specifications exceed the values and test conditions specified in the data sheet.

Notes on mounting

- ▶ Mount the sender and receiver on a level surface. (①)

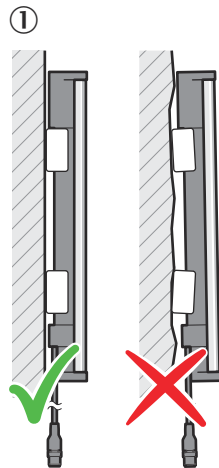

- ▶ Mount the sender and receiver such that a right-angled protective field is established, i.e., when mounted vertically at the same height. (②)
- ▶ For minor adjustments when aligning, the sender and receiver can be adjusted longitudinally in the brackets.

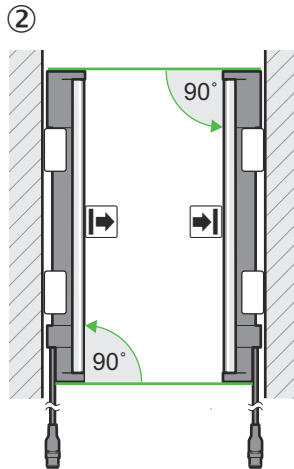

- Position the brackets near the ends of the housing. For devices with a protective field height > 300 mm, the distance between the bracket and the end of the housing must not exceed 1/4 of the length of the housing. If the device is exposed to strong vibrations during operation, mount the top bracket at a height where the offset in the safety light curtain housing rests on the bracket. (3)

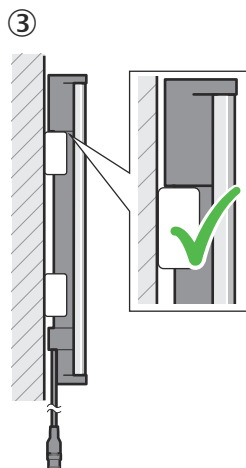

- Observe the tightening torque details for the particular bracket. Higher torques may damage the bracket. Lower torques do not offer sufficient protection against slipping of the sender and receiver. (4)

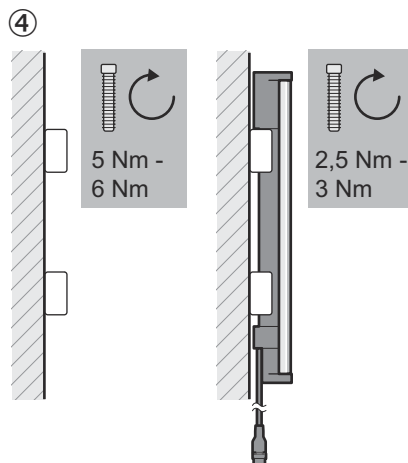

- Make sure that the sender and receiver are aligned correctly. The optical lens systems of the sender and the receiver must be located opposite one another. (5)

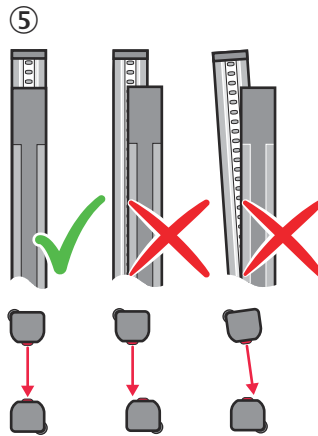

- If necessary, use a spirit level to check that the components are parallel. (6)

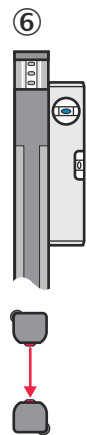

Further topics

- ["Minimum distance from the hazardous point", page 23](#)
- ["Minimum distance to reflective surfaces", page 25](#)
- ["Sender and receiver alignment", page 62](#)
- ["Alignment with the QuickFix bracket", page 64](#)
- ["Alignment with the FlexFix bracket or with the upgrade bracket", page 65](#)

5.3.1 Mounting the QuickFix bracket

Overview

2 QuickFix brackets are used to mount the sender and receiver.

The QuickFix bracket consists of 2 parts, which are pushed into each other. The two individual parts are connected with an M5 screw and the housing (sender or receiver) is clamped with form-fit clamping.

The two mounting surfaces for the brackets of the sender or receiver must be parallel and lie in the same plane.

Important information



NOTE

The following should be considered when mounting the QuickFix bracket:

- Select the appropriate length of the M5 screw to prevent any risk of injury from an overrun.
- When selecting the screw length, observe the wall thickness and the depth of the countersunk screw of the QuickFix bracket, [see figure 42, page 88](#)



NOTE

The QuickFix bracket has cable routing. Depending on the installation, the cable routing can make mounting easier.

Mount QuickFix bracket on a machine or profile frame

Table 10: Side and rear mounting with the QuickFix bracket

Mounting method	Description
On the side	Fasten the M5 screw to the machine or profile frame through the QuickFix bracket. A screw nut or threaded hole is required on the machine or profile frame (①).
	Fasten the M5 screw to the QuickFix bracket through the machine or profile frame. A screw nut is required for each QuickFix bracket (②).
	Fasten the M5 screw to the profile frame through the QuickFix bracket. A sliding nut is required on the profile frame (③).
On the back	Fasten the M5 screw to the machine or profile frame through the QuickFix bracket. A screw nut or threaded hole is required on the machine or profile frame (④).

Tightening torque: 5 Nm ... 6 Nm

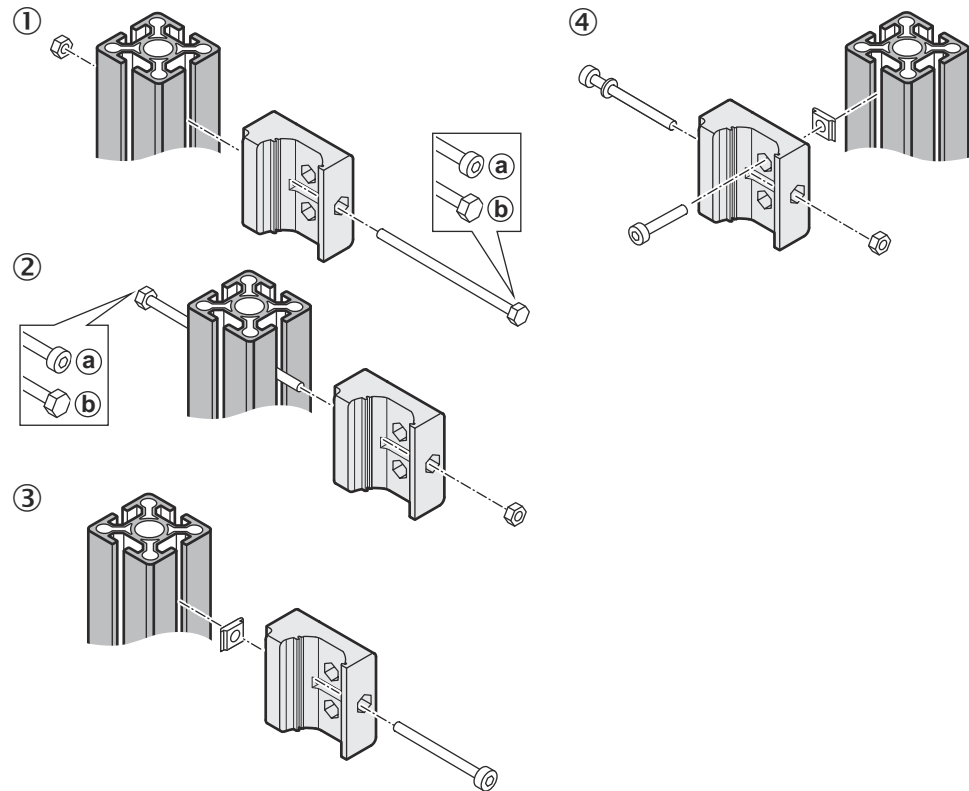

Figure 27: Mounting the QuickFix bracket to a profile

Secure the sender and receiver in the bracket

1. Insert the housing of the sender and receiver into the bracket so that it fits snugly.
2. Secure the position of the sensor and receiver in the bracket using the M5 screw.
Torque: 2.5 Nm to 3 Nm

5.3.2 Mounting the FlexFix bracket

Overview

In the FlexFix bracket, the sender and receiver can be rotated $\pm 15^\circ$ around their longitudinal axis.

2 FlexFix brackets are used to mount the sender and receiver.

As a rule, each FlexFix bracket is mounted to the mounting surface with 2 screws. In exceptional cases (e.g. reduced vibration and shock requirements), a FlexFix bracket can be mounted with only one screw if this does not impair the function.

Important information



NOTICE

The housing of the safety light curtain can become scratched if the screw heads protrude when the FlexFix brackets are mounted on the back.

This can be avoided by taking one of the following measures:

- ▶ Use flat-head screws with washers.
- ▶ If using cylinder head screws, use 2 screws per bracket and no washers.



NOTE

The FlexFix mounting kit (part number 2073543) contains 2 FlexFix brackets, one alignment tool, and the required screws, sliding nuts, and washers.

Further topics

- "Brackets", page 88

5.3.2.1 Mounting the FlexFix bracket on a machine or profile frame

Important information



NOTE

When selecting the screw length, the wall thickness of the FlexFix bracket must be taken into account.

Mounting the FlexFix bracket on a machine or profile frame

Table 11: Lateral and rear mounting with the FlexFix bracket

Mounting method	Description
On the side	With the M5 screw through the FlexFix bracket on the machine or profile frame (①).
	With the M5 screw through the FlexFix bracket on the profile frame. 2 sliding nuts are required on the profile frame (②).
On the back	With the M5 screw through the FlexFix bracket on the machine or profile frame. A screw nut or threaded hole is required on the machine or profile frame (③).

Tightening torque: 5 Nm ... 6 Nm

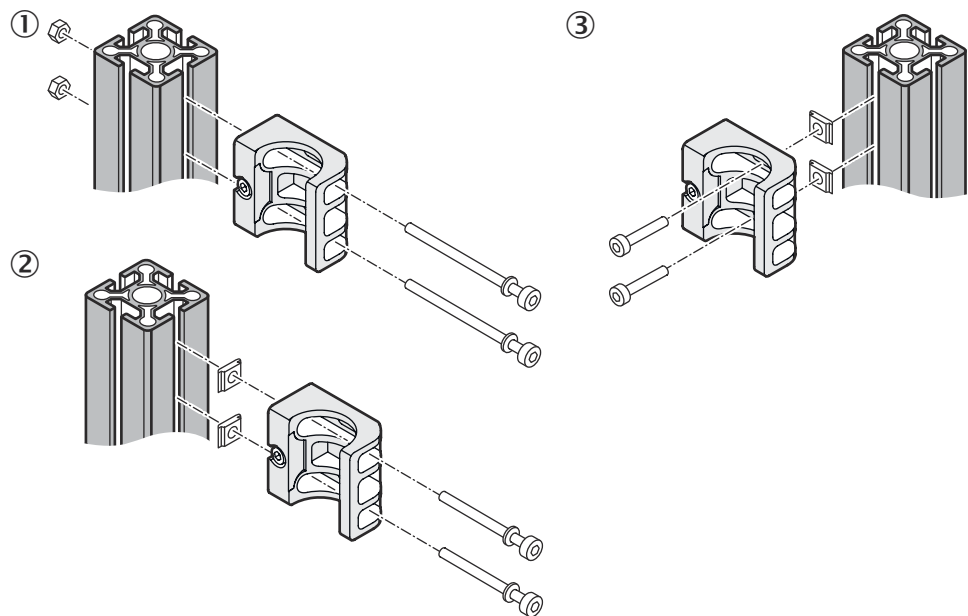

Figure 28: Mounting the FlexFix bracket to a profile frame

Secure the sender and receiver in the bracket

1. After assembling the FlexFix brackets, screw the sender or receiver into the FlexFix brackets from the front. (①)
2. Align the sender and receiver. (②)
3. Use an M5 screw to secure the position of the sender and receiver in the FlexFix bracket. (③)
Torque: 2.5 Nm to 3 Nm

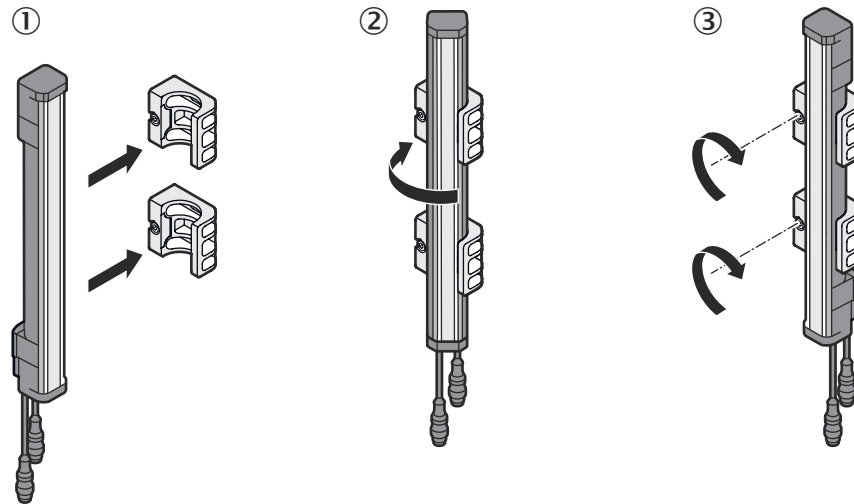

Figure 29: Inserting the safety light curtain in the FlexFix brackets



NOTE

The protective device can only be screwed in when both brackets are in alignment.

Recommendation:

1. Only hand-tighten the screws on the brackets at first.
2. Align the two brackets. To do this, place a straightedge or spirit level, for example, on the screw mounting surfaces of the brackets that are not being used.
3. Tighten the screws.

Further topics

- ["Sender and receiver alignment", page 62](#)
- ["Brackets", page 88](#)

5.3.2.2 Mount FlexFix bracket to the back of a device column

Overview

The FlexFix bracket can be mounted in the device column using sliding nuts.

Use washers between the FlexFix brackets and the device column if you want to mount the sender and receiver in the center of the device column.

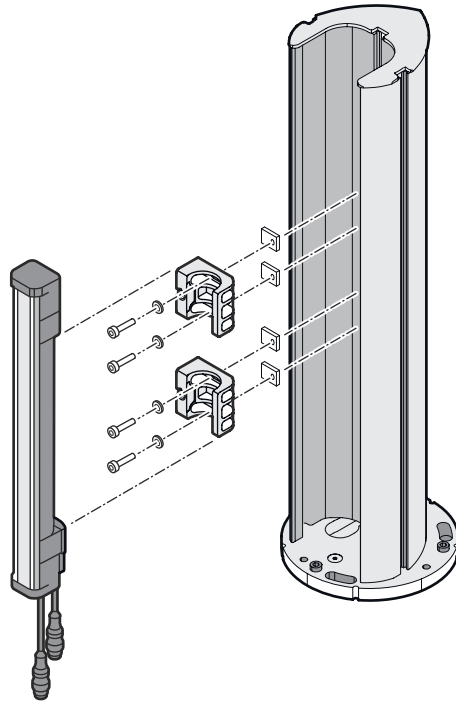

Figure 30: Mounting the FlexFix bracket to a device column (accessory)

Secure the sender and receiver in the bracket

1. After assembling the FlexFix brackets, screw the sender or receiver into the FlexFix brackets from the front.
2. Align the sender and receiver.
3. Use an M5 screw to secure the position of the sender and receiver in the FlexFix bracket.
Torque: 2.5 Nm to 3 Nm

Further topics

- ["Sender and receiver alignment"](#), page 62

5.3.3 Mounting the upgrade bracket

Overview

If an existing C4000 safety light curtain is mounted with a swivel-mount bracket or with a side bracket, it can be replaced with a deTec4 C4P-EAxx3SC05 safety light curtain using a replacement bracket. There is no need to drill new holes, since the existing ones can be used for the replacement bracket.

Complementary information

Additional information for mounting a safety light curtain with a replacement bracket can be found in the mounting instructions for the replacement bracket.

6 Electrical installation

6.1 Safety

Important information



DANGER

Hazard due to electrical voltage

Hazard due to unexpected starting of the machine

- ▶ Make sure that the machine is (and remains) disconnected from the voltage supply during the electrical installation.
- ▶ Make sure that the dangerous state of the machine is (and remains) switched off during electrical installation.
- ▶ Make sure that the outputs of the safety light curtain have no effect on the machine during the electrical installation work.
- ▶ Use a suitable voltage supply.



DANGER

Hazard due to lack of effectiveness of the protective device

The dangerous state may not be stopped in the event of non-compliance.

- ▶ Always connect the two OSSDs separately. The two OSSDs must not be connected to each other.
- ▶ Connect the OSSDs such that the machine controller processes both signals separately.



DANGER

Hazard due to lack of effectiveness of the protective device

The dangerous state may not be stopped in the event of non-compliance.

- ▶ Prevent the formation of a potential difference between the load and the protective device.



DANGER

Hazard due to lack of effectiveness of the protective device

Malfunctions can occur if unused inputs are wired incorrectly.

- ▶ Unused inputs must either not be connected or be permanently switched to LOW.



DANGER

Hazard due to lack of effectiveness of the protective device

The protective device can become disabled if the system connection cable is connected incorrectly.

- ▶ Make sure (e.g. by routing the cables appropriately) that the system connection cable can only be connected to the system connection of the protective device.

Prerequisites

- The safety light curtain has been safely integrated into the control system and the electrical system of the machine.
- Mounting has been correctly executed.

Example: Isolated connection of OSSD1 and OSSD2

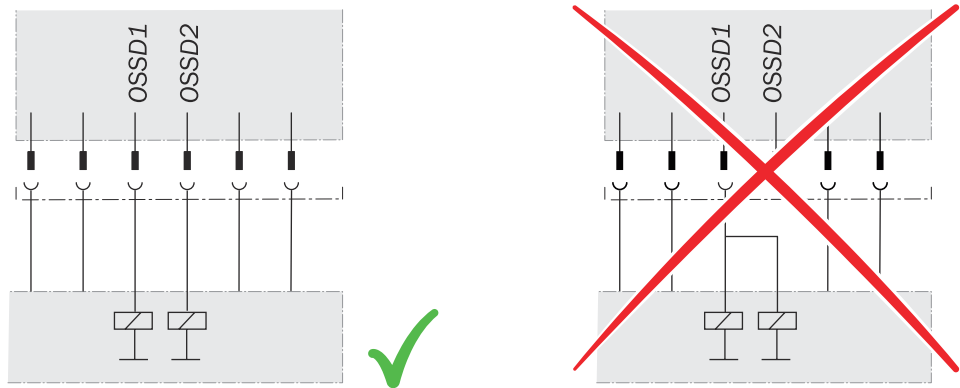

Figure 31: Dual-channel and isolated connection of OSSD1 and OSSD2

Avoiding any potential difference between load and protective device

If you connect loads to the output signal switching devices (switching outputs) that then also switch if controlled with negative voltage (e.g., electro-mechanical contactor without reverse polarity protection diode), you must connect the 0 V connections of these loads and those of the corresponding protective device separately and also directly to the same 0 V terminal strip. In the event of a fault, this is the only way to ensure that there can be no potential difference between the 0 V connections of the loads and those of the corresponding protective device.

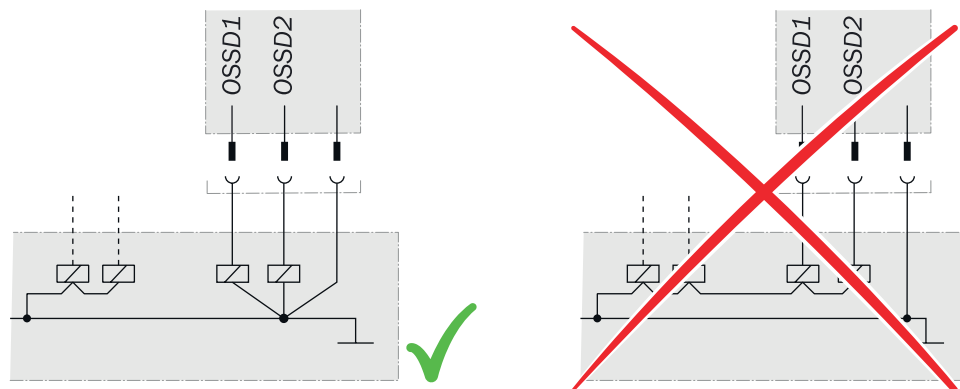

Figure 32: No potential difference between load and protective device

Further topics

- ["Integration in electrical control", page 30](#)
- ["Technical data", page 81](#)

6.2 System connection (M12, 5-pin)

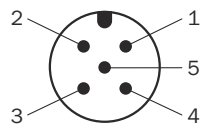

Figure 33: System connection (male connector, M12, 5-pin)

Table 12: System connection pin assignment (male connector, M12, 5-pin)

Pin	Wire color ¹⁾	Sender	Receiver
1	Brown	+24 V DC (voltage supply input)	+24 V DC (voltage supply input)
2	White	In2 (laser alignment aid push-button)	OSSD1 (switching output 1)
3	Blue	0 V DC (voltage supply input)	0 V DC (voltage supply input)
4	Black	In1 (laser alignment aid switch)	OSSD2 (output signal switching device 2)
5 ²⁾	Gray	MFP1 Not assigned	MFP1 Not assigned

¹⁾ Applies to the extension cables recommended as accessories.

²⁾ If the sender and the receiver are not connected, pin 5 can remain unassigned for a single system and, for example, a 4-pin cable with a 4-pin female connector can be used.

Further topics

- ["Integration in electrical control", page 30](#)

6.3 System connection (M12, 8-pin)

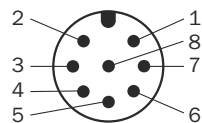

Figure 34: System connection (male connector M12, 8-pin)

Table 13: System connection pin assignment for SP1 system plug (M12 male connector, 8-pin)

Pin	Wire color ¹⁾	Sender	Receiver
1	White	Not assigned	In3 RES (reset pushbutton input)
2	Brown	+24 V DC (voltage supply input)	+24 V DC (voltage supply input)
3	Green	Not assigned	MFP3 ADO (application diagnostic output)
4	Yellow	Not assigned	In4 EDM (external device monitoring input)
5	Gray	In2 (laser alignment aid push-button)	OSSD1 (switching output 1)
6	Pink	In1 (laser alignment aid switch)	OSSD2 (output signal switching device 2)
7	Blue	0 V DC (voltage supply input)	0 V DC (voltage supply input)
8	Red	MFP1 Not assigned	MFP1 Not assigned

¹⁾ Applies to the extension cables recommended as accessories.

Further topics

- ["Integration in electrical control", page 30](#)

6.4 Extension connection (M12, 5-pin)

Pin assignment at the extension connection

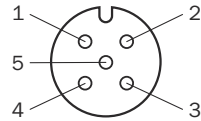

Figure 35: Extension connection (female connector M12, 5-pin)

Table 14: SP1 system plug extension connection pin assignment (M12 female connector, 5-pin)

PIN	Wire color ¹⁾	Sender	Receiver
1	Brown	24 V Out (voltage supply output)	24 V Out (voltage supply output)
2	White	Not assigned	In1 (EDM input)
3	Blue	0 V Out (voltage supply output)	0 V Out (voltage supply output)
4	Black	Sync-out	In2 (Reset pushbutton input: RES)
5	Gray	MFP2	MFP2 (ADO [application diagnostic output] / IO-Link)

¹⁾ Applies to the connecting cables recommended as accessories.

Further topics

- ["Integration in electrical control", page 30](#)

7 Configuration

7.1 Overview

Important information

Table 15: Functions and their configuration type

Function	Configuration type
Beam coding	DIP switch
Set to factory settings	
Restart interlock	Automatic configuration
External device monitoring (EDM)	
Application diagnostic output	
Status indication on both sides	

The following system plugs are available for configuring via a DIP switch:

- SP1 system plug

The SP1 system plug can be used on all of the senders and receivers of a single system.

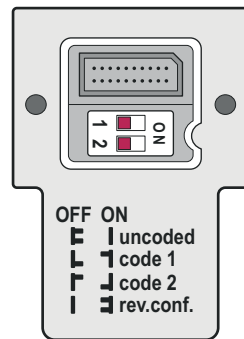

Figure 36: SP1 system plug with 2 DIP switches

Table 16: Overview of DIP switches

DIP switch	Function
1, 2	<ul style="list-style-type: none"> • Beam coding, see "Configuring beam coding", page 57 • Reset to factory settings, see "Reset to factory settings", page 56

Further topics

- "System plug", page 16
- "Configuring the restart interlock", page 58
- "Configuring external device monitoring (EDM)", page 59
- "Status indication on both sides", page 60

7.2 Factory settings

Table 17: Configurable functions when delivered

Function	Configuration when delivered
Beam coding.	Uncoded
Restart interlock	Not configured
External device monitoring (EDM)	Not configured

Complementary information

The device must be reset to the factory settings to change the configuration to the following functions:

- External device monitoring (EDM)
- Restart interlock

All other functions can be changed subsequently without resetting the safety light curtain to factory settings.

Further topics

- ["Reset to factory settings", page 56](#)

7.2.1 Reset to factory settings

Overview

The sender and receiver are reset to factory settings independently of each other. The procedure is the same for the sender and receiver.

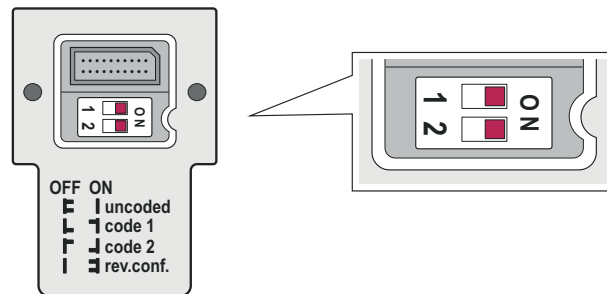

Figure 37: Reset to factory settings





Approach

1. Disconnect the device from the voltage supply.
2. Disconnect the device from all connected devices.
3. Set both DIP switches to ON, [see figure 37](#).
4. Switch on the voltage supply and disconnect it again within 10 s. ²⁾ During this time, the field indicator flashes alternately yellow and green.
5. Set both DIP switches to OFF.
6. Switch on the voltage supply.
- ✓ The field indicator flashes green.
- ✓ Sender: the STATE LED lights up red.
- ✓ Receiver: the OSSD light emitting diode lights up red.
7. Disconnect the device from the voltage supply.
- ✓ The device is reset to the factory settings.

²⁾ If the supply voltage is present for longer than 10 s, the safety light curtain changes to the locking state. Start again from step 1.

7.3 Configuration mode

Table 18: Configuration mode

	Sender	Receiver
Configuration mode is active	<ul style="list-style-type: none"> When resetting the sender to the factory settings 	<ul style="list-style-type: none"> When resetting the receiver to the factory settings A permissible change to the external device monitoring configuration has been discovered during switch-on The reset pushbutton was pressed in order to configure the restart interlock following switch-on
Display of the configuration mode	<ul style="list-style-type: none"> Field indicator:  Green STATE LED:  Red 	<ul style="list-style-type: none"> Field indicator:  Green OSSD LED:  Red

○ LED off. ◐ LED flashes. ● LED illuminates.

Provided that the device is in configuration mode, you can make further changes to the configuration:

- Configuring the restart interlock

Stopping configuration mode

- Briefly interrupt the voltage supply, then switch it back on.

7.4 Configuring beam coding

Overview

The beam coding “uncoded” allows for particularly short response times.

To protect against interference from systems in close proximity to each other, code 1 and code 2 must be used

The beam coding must be the same for the sender and receiver.

Configuring beam coding

The beam coding is configured using 2 DIP switches. The DIP switches are located on the inside of the system plug.

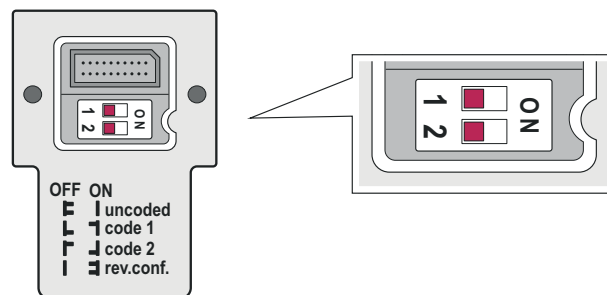

Figure 38: Configuring beam coding

Table 19: DIP switches and beam coding

DIP switch 1	DIP switch 2	Function
Off	Off	Uncoded (fast response time, delivery status)

DIP switch 1	DIP switch 2	Function
On	Off	Code 1 (protection against interference from systems in close proximity to each other)
Off	On	Code 2 (protection against interference from systems in close proximity to each other)
On	On	Reset to factory settings

The beam coding is indicated when the safety light curtain is switched on:

- Uncoded: the field indicator does not flash yellow
- Code 1: the field indicator flashes yellow once
- Code 2: the field indicator flashes yellow twice

Complementary information

You can also change the beam coding later. You do not need to reset the safety light curtain to the factory settings to do this.

During the first change to the beam coding, diagnostic LED 3 flashes white for 3 s. Afterwards, the diagnostic LED lights up white steadily.

Further topics

- ["Protection against interference from systems in close proximity to each other", page 27](#)
- ["Factory settings", page 55](#)

7.5 Configuring the restart interlock

Prerequisites

- A reset pushbutton is connected

Approach



NOTE

Skip the first and second steps if the device is already in configuration mode.

1. Disconnect the device from the voltage supply.
2. Switch on the voltage supply, then continue with the next step within 30 s. If more than 30 s elapses, start with step 1 again.
3. Press the reset pushbutton for between 1 and 3 s, then release it. If the reset pushbutton is pressed for more than 3 s, start with step 1 again.
 - ✓ The device is in configuration mode, the field indicator flashes green.
 - ✓ Diagnostic LED 4 flashes white and signals that the restart interlock has been configured.
 - ✓ The restart interlock is configured. The reset pushbutton must remain at the connection to which it was connected during configuration.
4. Disconnect the device from the voltage supply.
 - ✓ The device can now be put into operation.

To deactivate the restart interlock, reset the receiver to the factory settings.

Complementary information

The restart interlock is deactivated on delivery.

When the restart interlock is configured, the application diagnostic output located on the same plug connector as the reset pushbutton signals when the reset pushbutton needs to be pressed. The application diagnostic output signals “Reset required” and periodically switches between HIGH and LOW so that any suitable lamp that is connected flashes.

Further topics

- ["Factory settings", page 55](#)
- ["Restart interlock", page 32](#)

7.6 Configuring external device monitoring (EDM)

Prerequisites

- External device monitoring can only be configured when the wiring has been correctly performed.

Approach

1. Disconnect the device from the voltage supply.
2. Make sure that the wiring has been performed correctly and that the contactor has dropped out so that 24 V are present at the EDM input when the device is switched on
3. Switch on the voltage supply.
 - ✓ The device is in configuration mode, the field indicator flashes green.
 - ✓ Diagnostic LED 1 flashes white and signals that the external device monitoring has been configured.
 - ✓ External device monitoring is active. The wiring must remain at the connection to which it was connected during configuration.
4. If necessary: to configure the restart interlock, press the reset pushbutton for between 1 and 3 s, then release it. If diagnostic LED 4 flashes white, the restart interlock has been configured.
5. Disconnect the device from the voltage supply.
 - ✓ The device can now be put into operation.

To deactivate the external device monitoring, reset the receiver to the factory settings.

Complementary information

External device monitoring is deactivated on delivery.

Further topics

- ["External device monitoring \(EDM\)", page 33](#)
- ["Factory settings", page 55](#)

7.7 Configuring application diagnostic output

Overview

The application diagnostic outputs are configured automatically:

The following signals can be output over the application diagnostic output:

- Reset required
- Weak signal

A signal can be output on both the system and extension connections.

Table 20: Output signals on the system connection and extension connection

Configured function	Output signal on the application diagnostic output of the system connection	Output signal on the application diagnostic output of the extension connection
Not configured (factory settings)	Weak signal ¹⁾	Weak signal ¹⁾
Restart interlock with reset pushbutton on the system connection	Reset required	Weak signal ¹⁾
Restart interlock with reset pushbutton on the extension connection	Weak signal ¹⁾	Reset required

¹⁾ A weak signal is only signaled if no other output signal is configured on the respective application diagnostic output.

Weak signal

If the receiver of the ESPE is receiving a weak signal from the sender, e.g., because the sender and receiver are not correctly aligned to each other, or because the front screen is contaminated, the application diagnostic output signals the weak signal with the HIGH state.

Reset required

When the protective field of the ESPE is free again after an interruption, the application diagnostic output located on the same plug connector as the reset pushbutton signals that the reset pushbutton needs to be pressed. The application diagnostic output signals that reset is required and periodically switches between HIGH and LOW so that any suitable lamp that is connected flashes.

7.8 Status indication on both sides

The OSSD status and the status of the protective field are indicated via LEDs on the sender and receiver when the following applies:

- The sender and receiver are connected to one another in the control cabinet
- The sender and receiver are connected to one another via a T-connector

The status information is transferred from the receiver to the sender automatically. A configuration process is not required.

Further topics

- ["Connection of sender and receiver", page 34](#)

8 Commissioning

8.1 Overview

Prerequisites

- Project planning is completed.
- Mounting is completed.
- Electrical installation is completed.
- Dangerous state of the machine is and remains off during commissioning.
- The outputs of the device do not affect the machine during commissioning.
- The machine has been inspected and released by qualified safety personnel.
- Protective device works properly.
- The protection function is checked after each change to the machine or to the integration or the operating and boundary conditions of the device.

Approach

1. Check the DIP switches at the sender and receiver and set them correctly if required.
2. Fitting the system plug.
3. Switch on the voltage supply.
 - If a change to the configuration is detected or the device has been reset to factory settings, the device is in configuration mode and the field indicator flashes green.
4. Configure the restart interlock if required.
5. Once configuration is complete, briefly interrupt the voltage supply, then switch it back on.
6. If the configuration for the restart interlock or external device monitoring needs to be changed, reset the device to factory settings.
7. Once configuration is complete and the device has been restarted, align the sender and receiver.
8. Briefly interrupt the voltage supply, then switch it back on.
9. Check alignment.
10. Check the contactors.

Further topics

- ["Project planning", page 21](#)
- ["Mounting", page 41](#)
- ["Electrical installation", page 51](#)
- ["Configuration", page 55](#)
- ["Mounting the system plug", page 41](#)
- ["Configuration mode", page 57](#)
- ["Configuring the restart interlock", page 58](#)
- ["Factory settings", page 55](#)
- ["Sender and receiver alignment", page 62](#)
- ["Check during commissioning and modifications", page 66](#)

8.2 Switching on

Overview

After switching on, the sender and receiver initialize. All LEDs on the sender and receiver will light up briefly. They then indicate the following information:

- If a change to the configuration is detected or the device has been reset to factory settings, the device is in configuration mode and the field indicator flashes green
- The field indicator and diagnostic LEDs indicate the current configuration

- The receiver indicates the alignment quality using diagnostic LEDs 1, 2, 3 and 4 after a few seconds
Diagnostic LEDs 5 and 6 light up if the topmost beam (far from system plug) is synchronized. Diagnostic LEDs 7 and 8 light up if the bottommost beam (near system plug) is synchronized.
- In normal operation, the diagnostic LEDs indicate the current configuration. The field indicator, the STATE LED of the sender and the OSSD LED of the receiver also light up.

Further topics

- ["Configuration mode", page 57](#)
- ["Indications when switching on", page 72](#)

8.3 Sender and receiver alignment

Overview

Once mounting and electrical installation are complete, the sender and receiver must be aligned with each other.

Important information



DANGER

Dangerous state of the machine

- ▶ Make sure that the dangerous state of the machine is (and remains) switched off during the alignment process.
 - ▶ Make sure that the outputs of the safety light curtain do not affect the machine during the alignment process.
-



NOTE

While aligning to the indication of the alignment quality, pay attention to the synchronization indication of the topmost and bottommost beam and the bracket with which the sender and receiver are attached.

Further topics

- ["Alignment with the QuickFix bracket", page 64](#)
- ["Alignment with the FlexFix bracket or with the upgrade bracket", page 65](#)
- ["Indication of the alignment quality", page 65](#)
- ["Diagnostic LEDs", page 72](#)

8.3.1 Aligning the sender and receiver

Important information



DANGER

Dangerous state of the machine

- ▶ Make sure that the dangerous state of the machine is (and remains) switched off during the alignment process.
 - ▶ Make sure that the outputs of the safety light curtain do not affect the machine during the alignment process.
-

**DANGER**

Hazard due to lack of effectiveness of the protective device

The integrated laser alignment aid switches the OSSDs to the OFF state.

- ▶ Make sure that the outputs of the safety light curtain do not have any effect on the machine when the integrated laser alignment aid is activated.
- ▶ Only use the integrated laser alignment aid to align the safety light curtain.

**DANGER**

Hazard due to lack of effectiveness of the protective device

The integrated laser alignment aid may influence the receiver of a safety light curtain in close proximity. In such cases, the neighboring safety light curtain may not detect persons or parts of the body that require protection.

- ▶ Perform an alignment or take other measures to ensure that the laser beam only hits the front screen of the relevant receiver. The laser beam must not hit any external receiver should the integrated laser alignment aid be switched on by mistake or due to a fault. An external receiver is a receiver that is not part of the same safety light curtain.
- ▶ During alignment in particular, make sure that the laser beam does not hit any external receiver.

Prerequisites

- Sender and receiver have been mounted correctly
- The protective field is free of objects. Neither objects nor body parts (e.g. hand, tool, optional AR60 laser alignment aid) are in the protective field. Otherwise, at most diagnostic LEDs 1 and 2 light up during alignment.

Approach

1. Switch on the voltage supply for the safety light curtain.
2. Roughly align the sender with the receiver: Rotate the sender so that it points toward the receiver.
 - ▶ If a pushbutton or switch has been connected for the integrated laser alignment aid, activate the integrated laser alignment aid. Turn the sender so that the beam of the integrated laser alignment aid hits the area of diagnostic LEDs 1, 2, 3 and 4 on the longitudinal axis of the receiver.
3. Align the receiver to the sender: Turn the receiver and pay attention to the indication of the alignment quality and the synchronization status of the topmost and bottommost beams.
 - ▶ If a hand or a tool is in the protective field during the alignment, but diagnostic LEDs 5, 6, 7 and 8 are already lit up, remove the object and continue with step 6.
4. Align the sender to the receiver with more precision as needed and pay attention to the indication of the alignment quality and the synchronization status of the topmost and bottommost beams.
5. Align the receiver to the sender with more precision as needed and pay attention to the indication of the alignment quality and the synchronization status of the topmost and bottommost beams.
6. If at least 3 (better: 4) of diagnostic LEDs 1, 2, 3 and 4 and diagnostic LEDs 5, 6, 7 and 8 light up blue, fix the components in place in the brackets. Torque: 2.5 Nm to 3 Nm.
7. Switch the voltage supply off and then on again.
8. Check diagnostic LEDs 1 to 4 for the alignment quality and diagnostic LEDs 5 to 8 for the synchronization of the topmost and bottommost beams in order to ensure that the components are still aligned with each other correctly.

**NOTE**

If suitable wiring has been established, activate the integrated laser alignment aid.

Complementary information

In many cases, the optional AR60 laser alignment aid and the alignment tool available as an accessory can make alignment even easier. If deflector mirrors are installed, the laser alignment aid can be used at the receiver. If there is a large protective field height, it can be used at the top end of the sender and at the receiver.

Since the optional AR60 laser alignment aid is placed with the adapter inside the protective field of the safety light curtain, at most diagnostic LEDs 1 and 2 light up blue and the OSSD LED lights up red. To check whether the OSSD LED of the receiver lights up green and diagnostic LEDs 5,6,7 and 8 light up blue, remove the optional AR60 laser alignment aid.

Further topics

- ["Indication of the alignment quality", page 65](#)
- ["Mounting", page 41](#)
- ["Laser alignment aid", page 35](#)

8.3.2 Alignment with the QuickFix bracket**Prerequisites**

- The sender and receiver are mounted with a QuickFix bracket

Alignment with the QuickFix bracket

The QuickFix bracket offers you the following adjustment options for aligning the sender and receiver with each other:

- Shift vertically

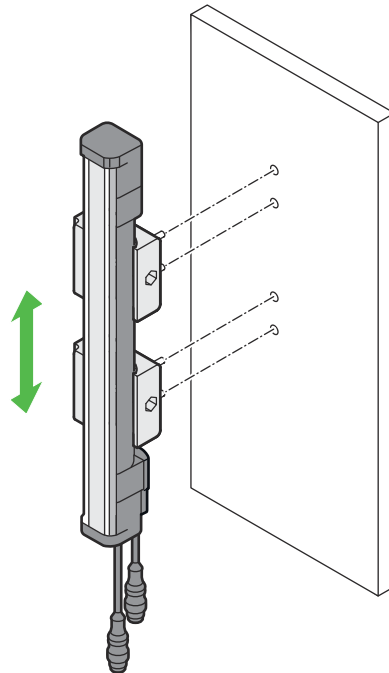

Figure 39: QuickFix bracket: adjust vertically

8.3.3 Alignment with the FlexFix bracket or with the upgrade bracket

Prerequisites

- A FlexFix bracket or upgrade bracket is used to mount the sender and receiver.

Alignment with the FlexFix bracket or the upgrade bracket

The FlexFix bracket or upgrade bracket offer you the following adjustment options for aligning the sender and receiver with each other:

- Shift vertically
- Rotate ($\pm 15^\circ$)

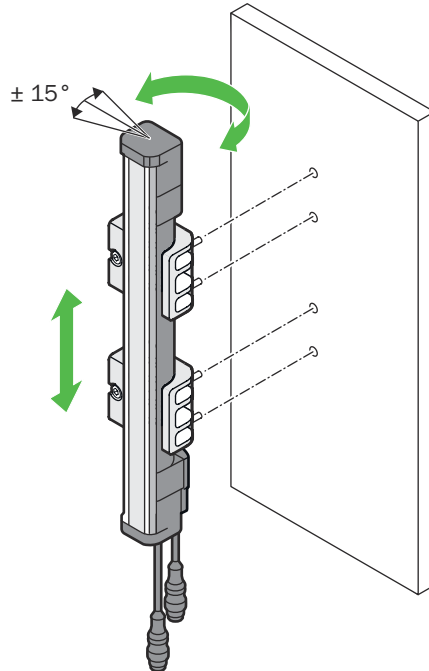

Figure 40: FlexFix bracket: adjust vertically/rotate



NOTE

Recommendation for aligning a long device so that it rotates uniformly in both brackets:

- ▶ Grab the alignment device roughly in the center between the two brackets.

8.3.4 Indication of the alignment quality

Important information



NOTE

As soon as the diagnostic LEDs 1, 2 and 3 light up, the alignment is good and availability is stable.

Body parts or objects in the protective field (e.g., hand, tool, AR60 optional laser alignment aid) may impair the indication of the alignment quality (at most diagnostic LEDs 1 and 2 light up).

- ▶ Ensure that no body parts or objects are in the protective field
Or
- ▶ Watch out for diagnostic LEDs 5, 6, 7 and 8. If diagnostic LEDs 5, 6, 7 and 8 light up, the alignment is good and availability is stable.

Indication of the alignment quality

Position of LEDs: see "Receiver displays", page 18.

If front screen contamination increases in ongoing operation, the laser alignment aid switches on or the alignment takes longer than 3 seconds, the receiver shows the alignment quality again.

Once the safety light curtain is aligned and the protective field is clear (field indicator: flashing yellow or lit up green), the alignment quality display switches off after a certain period of time.

Table 21: Indication of the alignment quality

LEDs								Meaning
Diagnostics LEDs								
1	2	3	4	5	6	7	8	
○	○	○	○	○	○	○	○	Alignment is inadequate, or the protective field is at least partially interrupted. The receiver cannot synchronize with the sender.
● Blue	○	○	○					At least one beam is synchronized. However, the alignment is inadequate, or the protective field is at least partially interrupted.
● Blue	● Blue	○	○					The alignment or the signal strength is still not sufficient for stable availability, or the protective field is at least partially interrupted. ¹⁾
● Blue	● Blue	● Blue	○					Alignment is good, stable availability. ^{1) 2)}
● Blue	● Blue	● Blue	● Blue					Alignment is very good. ¹⁾
				● Blue	● Blue			The topmost light beam (far from system plug) is synchronized.
						● Blue	● Blue	The bottommost light beam (near system plug) is synchronized.

○ LED off. ● LED flashes. ● LED illuminates.

- 1) If external device monitoring is configured and there is an EDM warning, diagnostic LED 1 flashes, while the other diagnostic LEDs 2, 3 and 4 indicate the alignment quality. If there is an error on the reset pushbutton, diagnostic LED 4 flashes, while the other diagnostic LEDs 1, 2 and 3 indicate the alignment quality.
- 2) If the protective fields are very wide, there is a possibility that diagnostic LED 4 does not light up, even with optimal alignment.

Further topics

- "Indications when switching on", page 72

8.4 Check during commissioning and modifications

The thorough check is intended to ensure that the safety functions are fulfilling their planned purpose and whether persons are being adequately protected.

- ▶ Carry out the checks specified in the test plan of the manufacturer of the machine and the operating entity.

9 Operation

9.1 Overview

Information on the status as well as diagnostics and troubleshooting of the safety light curtain can be displayed as follows:

- **Diagnostics LEDs**
Status and fault information, as well as diagnostics data, are displayed directly on the sender and receiver by means of the diagnostics LEDs.
- **IO-Link**
Status and error information as well as diagnostics data can be read by means of an IO-link interface.
- **NFC**
Status and fault information, as well as diagnostics data, can be read out to an NFC-capable device by means of an integrated NFC interface.

Complementary information

You can find additional information on IO-Link in the IODD and the SDD for SOPAS ET.

You can find additional information on NFC in the SICK Safety Assistant app.

Further topics

- ["Diagnostic LEDs", page 72](#)

9.2 Regular thorough check

The thorough check is intended to ensure that the safety functions are fulfilling their planned purpose and whether persons are being adequately protected.

- ▶ Carry out the checks specified in the test plan of the manufacturer of the machine and the operating entity.

9.3 LEDs

Sender

Position of LEDs: see ["Sender displays", page 17](#).

If the sender and receiver are connected to each other by a cable, the LEDs on the sender indicate the same status as the LEDs on the receiver during normal operation. The STATE LED on the sender adopts the status of the OSSD LED on the receiver.

If the sender and receiver are not connected with each other, the STATE LED on the sender lights up yellow when the sender is in operation and no faults are present.

Receiver

Position of LEDs: see ["Receiver displays", page 18](#).

Table 22: LEDs on the receiver during normal operation

LEDs		Diagnostics LEDs								Meaning
OSSD	Field	1	2	3	4	5	6	7	8	
		● White								
				● White						Beam coding 1 or 2 is configured.

LEDs										Meaning	
OSSD	Field	Diagnostics LEDs									
		1	2	3	4	5	6	7	8		
					● White						Restart interlock is configured.
	☀️ Yel- low										The receiver has recognized beams from several senders. Remedial measures: <ul style="list-style-type: none"> ▶ Check the distance to senders of the same design. ▶ Check the beam coding of the receiver and systems in close proximity. ▶ Make sure that light beams from a different sender cannot hit the receiver (exception: when one of the two systems uses code 1 and the other uses code 2), see "Protection against interference from systems in close proximity to each other", page 27.
● Red	☀️ ● Yellow/ green	○	○	○	○	○	○	○	○		Reset of the configuration to factory settings is activated.
● Red	● Green										The device is in configuration mode following a change to the configuration.
● Red	● Green										The laser alignment aid of the sender is switched on. Its own protective field is clear.
● Red	● Red										Its own protective field is interrupted. OR The protective field is clear. The reset button has just been actuated.
● Red	☀️ Yel- low										The protective field is clear. Reset required.
					☀️ Yel- low						The reset pushbutton is defective or is being actuated continuously. Check the wiring of the reset pushbutton.

LEDs										Meaning	
OSSD	Field	Diagnostics LEDs									
		1	2	3	4	5	6	7	8		
● Red		☀ Yel-low									EDM warning: The EDM input has no signal. Check contactors and wiring. Switch the voltage supply off and back on again.

○ LED off. ☀ LED flashes. ● LED illuminates. Empty cells mean that the LED lights up, flashes, or is off.

If front screen contamination increases in ongoing operation, the laser alignment aid switches on or the alignment takes longer than 3 seconds, the receiver shows the alignment quality again.

Further topics

- ["Indication of the alignment quality", page 65](#)
- ["Diagnostic LEDs", page 72](#)

10 Maintenance

10.1 Regular cleaning

Overview

Depending on the ambient conditions of the safety light curtain, the front screens must be cleaned regularly and in the event of contamination. Static charges can cause dust particles to be attracted to the front screen.

The weld spark guard and deflector mirrors must be cleaned regularly and in the event of contamination.

With increasing contamination, the 2 illuminated diagnostic LEDs 1 and 2 indicate that the receiver is receiving a weak signal from the sender. If the device is not cleaned and contamination increases, the safety light curtain switches to the OFF state when contamination is high.

Important information



DANGER

Hazard due to lack of effectiveness of the protective device

Persons and parts of the body to be protected may not be recognized in case of non-observance.

- ▶ Regularly check the degree of contamination on all components based on the application conditions.
- ▶ Observe the information concerning test rod testing.



DANGER

Hazard due to lack of effectiveness of the protective device

Persons and parts of the body to be protected may not be recognized in case of non-observance.

- ▶ Make sure that the optical properties of the front screens of the sender and receiver are not changed, e.g., by:
 - beading water, mist, frost, or ice formation. If applicable, remove films or other types of contamination, disconnect the voltage supply of the receiver and then switch it back on.
 - Scratches or damage. Replace the device whose front screen is scratched or damaged.
- ▶ Make sure that all reflective surfaces and objects maintain a minimum distance from the protective field.
- ▶ Make sure that no dispersive media (e.g., dust, fog, or smoke) are within the calculated minimum distance from the protective field.



NOTICE

- ▶ Do not use any aggressive cleaning agents.
- ▶ Do not use any abrasive cleaning agents.
- ▶ We recommend anti-static cleaning agents.
- ▶ We recommend the use of anti-static plastic cleaner (SICK part number 5600006) and the SICK lens cloth (SICK part number 4003353).

Prerequisites

- Dangerous state of the machine is and remains off during cleaning.
- The outputs of the device do not affect the machine during cleaning.

Approach

1. Remove dust from the front screen using a soft, clean brush.
2. Then wipe the front screen with a clean, damp cloth.
3. Check the position of the sender and receiver after cleaning.
4. Check the effectiveness of the protective device.

Further topics

- ["Test rod check", page 37](#)
- ["Minimum distance to reflective surfaces", page 25](#)

10.2 Regular thorough check

The thorough check is intended to ensure that the safety functions are fulfilling their planned purpose and whether persons are being adequately protected.

- ▶ Carry out the checks specified in the test plan of the manufacturer of the machine and the operating entity.

11 Troubleshooting

11.1 Overview

Information on the status as well as diagnostics and troubleshooting of the safety light curtain can be displayed as follows:

- **Diagnostics LEDs**
Status and fault information, as well as diagnostics data, are displayed directly on the sender and receiver by means of the diagnostics LEDs.
- **IO-Link**
Status and error information as well as diagnostics data can be read by means of an IO-link interface.
- **NFC**
Status and fault information, as well as diagnostics data, can be read out to an NFC-capable device by means of an integrated NFC interface.

Complementary information

You can find additional information on IO-Link in the IODD and the SDD for SOPAS ET.

You can find additional information on NFC in the SICK Safety Assistant app.

Further topics

- ["Diagnostic LEDs", page 72](#)

11.2 Safety



DANGER

Hazard due to lack of effectiveness of the protective device

Persons and parts of the body to be protected may not be recognized in case of non-observance.

- ▶ Immediately shut the machine down if the behavior of the machine cannot be clearly identified.
 - ▶ Immediately put the machine out of operation if you cannot clearly identify or allocate the fault and if you cannot safely remedy the fault.
 - ▶ Secure the machine so that it cannot switch on unintentionally.
-



NOTE

Additional information on troubleshooting can be found at the responsible SICK subsidiary.

11.3 Diagnostic LEDs

11.3.1 Indications when switching on

Overview

Immediately after switching on, all LEDs on the sender and receiver briefly light up.

Following this, the information below regarding configuration is indicated briefly.

Sender

Position of LEDs: [see "Sender displays", page 17.](#)

Table 23: Indications on the sender when switching on

LEDs		Meaning
STATE	Field	
	Yellow, flashes once	Beam coding, code 1 is configured.
	Yellow, flashes twice	Beam coding, code 2 is configured.
Red	Yellow/green	Reset of the configuration to factory settings is activated, see "Factory settings", page 55 .
Red	Green	Device is in configuration mode, see "Configuration mode", page 57 .

○ LED off. LED flashes. ● LED illuminates. Empty cells mean that the LED lights up, flashes, or is off.

Receiver

Position of LEDs: see ["Receiver displays", page 18](#).

Table 24: Indications on the receiver when switching on

LEDs										Meaning	
OSSD	Field	Diagnostic LEDs									
		1	2	3	4	5	6	7	8		
	Yellow, flashes once			● White (3 s)							Beam coding, code 1 is configured.
	Yellow, flashes twice			● White (3 s)							Beam coding, code 2 is configured.
		● White (3 s)									External device monitoring (EDM) is configured.
					● White (3 s)						Restart interlock is configured.
Red	Yellow/green	○	○	○	○	○	○	○	○	○	Reset of the configuration to factory settings is activated, see "Factory settings", page 55 .
Red	Green										Device is in configuration mode, see "Configuration mode", page 57 . When a function is configured, the corresponding diagnostic LED flashes.

○ LED off. LED flashes. ● LED illuminates. Empty cells mean that the LED lights up, flashes, or is off.

After the configuration is displayed, diagnostic LEDs 1, 2, 3 and 4 indicate the alignment quality. Additionally, the synchronization status of the topmost and bottommost beams of the safety light curtain are displayed by means of diagnostic LEDs 5 and 6 as well as 7 and 8.

If the configuration was changed, the diagnostic LEDs flash white for 3 s upon activation.

Once the safety light curtain is aligned and the protective field is clear (field indicator: flashing yellow or lit up green), the alignment quality display switches off after a certain period of time.

Table 25: Indication of the alignment quality

LEDs								Meaning
Diagnostics LEDs								
1	2	3	4	5	6	7	8	
○	○	○	○	○	○	○	○	Alignment is inadequate, or the protective field is at least partially interrupted. The receiver cannot synchronize with the sender.
● Blue	○	○	○					At least one beam is synchronized. However, the alignment is inadequate, or the protective field is at least partially interrupted.
● Blue	● Blue	○	○					The alignment or the signal strength is still not sufficient for stable availability, or the protective field is at least partially interrupted. ¹⁾
● Blue	● Blue	● Blue	○					Alignment is good, stable availability. ^{1) 2)}
● Blue	● Blue	● Blue	● Blue					Alignment is very good. ¹⁾
				● Blue	● Blue			The topmost light beam (far from system plug) is synchronized.
						● Blue	● Blue	The bottommost light beam (near system plug) is synchronized.

○ LED off. ◐ LED flashes. ● LED illuminates.

- 1) If external device monitoring is configured and there is an EDM warning, diagnostic LED 1 flashes, while the other diagnostic LEDs 2, 3 and 4 indicate the alignment quality. If there is an error on the reset pushbutton, diagnostic LED 4 flashes, while the other diagnostic LEDs 1, 2 and 3 indicate the alignment quality.
- 2) If the protective fields are very wide, there is a possibility that diagnostic LED 4 does not light up, even with optimal alignment.

11.3.2 Status indication

Overview

During operation, the status of the safety light curtain is indicated with LEDs.

Sender

Position of the LEDs: [see "Sender displays", page 17](#).

If the sender and receiver are connected to each other by a cable, the LEDs on the sender indicate the same status as the LEDs on the receiver during normal operation. The STATE LED on the sender adopts the status of the OSSD LED on the receiver.

If the sender and receiver are not connected with each other, the STATE LED on the sender lights up yellow when the sender is in operation and no faults are present.

Receiver

Position of the LEDs: [see "Receiver displays", page 18](#).

Table 26: LEDs on the receiver during normal operation

LEDs										Meaning	
OSSD	Field	Diagnostics LEDs									
		1	2	3	4	5	6	7	8		
		● White									EDM is configured.
				● White							Beam coding 1 or 2 is configured.
					● White						Restart interlock is configured.
	☀ Yel- low										<p>The receiver has recognized beams from several senders.</p> <p>Remedial measures:</p> <ul style="list-style-type: none"> ▶ Check the distance to senders of the same design. ▶ Check the beam coding of the receiver and systems in close proximity. ▶ Make sure that light beams from a different sender cannot hit the receiver (exception: when one of the two systems uses code 1 and the other uses code 2), see "Protection against interference from systems in close proximity to each other", page 27.
● Red	☀ Yellow/ ● Green	○	○	○	○	○	○	○	○	○	Reset of the configuration to factory settings is activated.
● Red	● Green										The device is in configuration mode following a change to the configuration.
● Red	● Green										The laser alignment aid of the sender is switched on. Its own protective field is clear.
● Red	● Red										<p>Its own protective field is interrupted.</p> <p>OR</p> <p>The protective field is clear.</p> <p>The reset button has just been actuated.</p>
● Red	☀ Yel- low										The protective field is clear. Reset required.

LEDs										Meaning	
OSSD	Field	Diagnostics LEDs									
		1	2	3	4	5	6	7	8		
					☀ Yel-low						The reset pushbutton is defective or is being actuated continuously. Check the wiring of the reset pushbutton.
● Red		☀ Yel-low									EDM warning: The EDM input has no signal. Check contactors and wiring. Switch the voltage supply off and back on again.

○ LED off. ☀ LED flashes. ● LED illuminates. Empty cells mean that the LED lights up, flashes, or is off.

If front screen contamination increases in ongoing operation, the laser alignment aid switches on or the alignment takes longer than 3 seconds, the receiver shows the alignment quality again.

Further topics

- ["Indication of the alignment quality", page 65](#)

11.3.3 Fault indicators

Overview

In the event of a fault, the type of fault is indicated by the LED display on the sender or receiver.

Sender

Position of the LEDs: [see "Sender displays", page 17.](#)

Table 27: Fault indication on the sender

LEDs		Possible cause	Troubleshooting
STATE	Field		
● Yellow	○	Normal operation, no cable connection between sender and receiver. ¹⁾	–
● Yellow	● Red	Fault in the voltage supply.	<ul style="list-style-type: none"> ▶ Check the voltage supply, see "Technical data", page 81. ▶ Switch the voltage supply off and back on again. ▶ If the fault persists, replace the sender, see "Ordering information", page 87.
☀ Yellow	● Red	The sender identified an internal fault.	<ul style="list-style-type: none"> ▶ Switch the voltage supply off and back on again. ▶ If the fault persists, replace the sender, see "Ordering information", page 87.
● Red	☀ Yellow/● Green	Reset of the configuration to factory settings is activated.	For additional information: see "Factory settings", page 55.
● Red	● Green	The device is in configuration mode following a change to the configuration.	For additional information: see "Configuration mode", page 57.
● Green	● Red	A problem occurred when resetting the configuration to factory settings.	▶ Restart configuration, see "Factory settings", page 55.

LEDs		Possible cause	Troubleshooting
STATE	Field		
○	◐ Red	The voltage is or was too high when operating the sender.	<ul style="list-style-type: none"> ▶ Check the voltage supply, see "Technical data", page 81. ▶ Replace the sender, see "Ordering information", page 87.

○ LED off. ◐ LED flashes. ● LED illuminates.

- 1) If the sender and receiver are connected by a cable, the LEDs on the sender indicate the same status as the LEDs on the receiver during normal operation. The STATE LED on the sender adopts the status of the OSSD LED on the receiver.

Receiver

Position of the LEDs: see ["Receiver displays", page 18](#).

Table 28: Fault indication on the receiver

LEDs										Possible cause	Troubleshooting
OSSD	Field	Diagnostics LEDs									
		1	2	3	4	5	6	7	8		
● Red	◐ Red	◐ Red	○	○	○	○	○	○	○	An internal fault has occurred.	<ul style="list-style-type: none"> ▶ Switch the voltage supply off and back on again. ▶ If the fault continues to persist, replace the receiver, see "Ordering information", page 87.
● Red	◐ Red	○	◐ Red	○	○	○	○	○	○	Fault in the voltage supply.	<ul style="list-style-type: none"> ▶ Check the voltage supply and the power supply unit, see "Technical data", page 81. ▶ Switch the voltage supply off and back on again. ▶ If the fault continues to persist, replace the receiver, see "Ordering information", page 87.
● Red	◐ Red	○	◐ Red	○	◐ Red	○	○	○	○	Permanent error in the voltage supply.	<ul style="list-style-type: none"> ▶ Replace device, see "Ordering information", page 87.
● Red	◐ Red	○	◐ Red	◐ Red	◐ Red	○	○	○	○	General error in the configuration.	<ul style="list-style-type: none"> ▶ Check configuration settings including the permitted combination of functions. ▶ Make sure that the correct system plug is used. ▶ Reset device to factory settings.

LEDs										Possible cause	Troubleshooting
OSSD	Field	Diagnostics LEDs									
		1	2	3	4	5	6	7	8		
● Red	☀ Red	○	○	○	☀ Red	○	○	○	○	A wiring fault has been identified at the OSSDs or at an input. E.g., at an OSSD: overvoltage, short-circuit, cross-circuit, permissible load capacity exceeded. E.g., at an input: invalid signal, unexpected signal.	<ul style="list-style-type: none"> ▶ Check the system wiring for a fault. Make sure that the OSSDs and inputs have been wired correctly, see "Integration in electrical control", page 30. ▶ Switch the voltage supply off and back on again. ▶ If the fault continues to persist, replace the defective components, see "Ordering information", page 87.
● Red	☀ Red	○	☀ Red	☀ Red	○	○	○	○	○	A wiring fault has been detected.	<ul style="list-style-type: none"> ▶ Check the system wiring for a fault. ▶ Make sure that the IO-link interface was wired correctly. ▶ Switch the voltage supply off and back on again.
● Red	☀ Red	☀ Red	○	☀ Red	○	○	○	○	○	Incompatible device detected.	<ul style="list-style-type: none"> ▶ For a sender-receiver connection, ensure that the sender and receiver devices are compatible, see "Connection of sender and receiver", page 34.
● Red		☀ Yellow								EDM warning (only if the external device monitoring function is active): The OSSDs have constantly been in the OFF state since the safety light curtain was switched on and no signal is present at the EDM input.	<p>Normally, this message is displayed only briefly after switching on and goes out as soon as the voltage supply for the auxiliary contacts is established at the contactors. If the message is displayed for longer:</p> <ul style="list-style-type: none"> ▶ Check the contactors. ▶ Check the wiring of the contactors. ▶ Switch the voltage supply off and back on again.

LEDs										Possible cause	Troubleshooting
OSSD	Field	Diagnostics LEDs									
		1	2	3	4	5	6	7	8		
● Red	☀ Red	● Red	○	○	○	☀ Red	○	○	○	EDM fault (only if the external device monitoring function is active): The status of the EDM input has not changed within 300 ms following a change to the OSSD status. OR The status of the EDM input has changed even though the OSSD status has not.	<ul style="list-style-type: none"> ▶ Check the contactors. ▶ Check the wiring of the contactors. ▶ Switch the voltage supply off and back on again.
● Red	☀ Yellow/green	○	○	○	○	○	○	○	○	Reset of the configuration to factory settings is activated.	For additional information: see "Factory settings", page 55.
● Red	● Green									The device is in configuration mode following a change to the configuration.	For additional information: see "Configuration mode", page 57.
● Red	☀ Red	☀ Red	☀ Red	☀ Red	☀ Red	○	○	○	○	A problem occurred when resetting the configuration to factory settings.	<ul style="list-style-type: none"> ▶ Restart configuration, see "Factory settings", page 55.
					☀ Yellow					Reset pushbutton fault.	<ul style="list-style-type: none"> ▶ Check that the reset pushbutton is working. The reset pushbutton may be defective or is being pressed continuously. ▶ Check the wiring of the reset pushbutton.
● Red	☀ Red	○	○	● Red	○	○	○	○	☀ Red	Different beam coding on the sender and receiver detected.	<ul style="list-style-type: none"> ▶ Configure sender and receiver with the same beam coding. ▶ Switch the voltage supply off and back on again.

○ LED off. ☀ LED flashes. ● LED illuminates. Empty cells mean that the LED lights up, flashes, or is off.

12 Decommissioning

12.1 Disposal

Approach

- ▶ Always dispose of unusable devices in accordance with national waste disposal regulations.



Complementary information

SICK will be glad to help you dispose of these devices on request.

13 Technical data

13.1 Data sheet

Table 29: General system data

	Minimum	Typical	Maximum
Protective field height, depending on type	300 mm, 450 mm, 750 mm		
Resolution (detection capability)	30 mm		
Protective field width ^{1) 2) 3)}			
Resolution 30 mm	0 m ... 24 m	0 ... 30 m	
Protection class ⁴⁾	III (IEC 61140)		
Enclosure rating ⁵⁾	IP65 (IEC 60529) IP67 (IEC 60529)		
Supply voltage U_V at the device ^{6) 7) 8)}	19.2 V	24 V	28.8 V
Current consumption of the overall system (system connection via system plug)			2 A
Residual ripple ⁹⁾			± 10%
Synchronization	Optical		
Typ (IEC 61496)	Type 4		
Category (ISO 13849)	Category 4		
Performance level (ISO 13849) ¹⁰⁾	PL e		
Safety integrity level (IEC 61508) ¹⁰⁾	SIL 3		
Safety integrity level (IEC 62061) ¹⁰⁾	SIL 3		
PFH _D (mean probability of a dangerous failure per hour)	1.53 x 10 ⁻⁸		
T _M (mission time)	20 years (ISO 13849-1)		
Safe status when a fault occurs	At least one OSSD is in the OFF state.		
Power-up delay of sender and receiver after supply voltage is applied		2 s	
Test rod speed at which the test rod is reliably detected ¹¹⁾	0 m/s ... 1.6 m/s		

- 1) If the protective fields are very wide, there is a possibility that all four diagnostic LEDs 1, 2, 3 and 4 will not light up even when alignment is optimal.
- 2) The minimum scanning range specifies a range in which a function is guaranteed to operate correctly and safely under industrial conditions. A sufficient level of signal reserve to ensure very high availability is included in the calculation.
- 3) The typical scanning range specifies a range in which the safety light curtain operates correctly and safely under industrial conditions. The level of signal reserve is enough to ensure high availability.
- 4) SELV/PELV safety extra-low voltage.
- 5) The specified enclosure rating only applies when the system plug is fitted.
- 6) The external voltage supply must be capable of bridging a brief power failure of 20 ms as specified in IEC 60204-1. Suitable power supply units are available as accessories from SICK.
- 7) A fuse rated maximum 4 A shall be installed in the 24 V DC power supply circuit to the device in order to limit the available current.
- 8) All inputs of the safety light curtain must be supplied by the same voltage supply. If the sender and receiver are connected to each other, they must be supplied by the same voltage supply.
- 9) Within the limits of U_V .
- 10) For more detailed information on the exact configuration of your machine, please contact your relevant SICK subsidiary.
- 11) Direction of movement and axis of the test rod perpendicular to the protective field.

Table 30: Mechanical data

deTec4 C4P-EAxxx3SC05	
Housing material	Aluminum extruded profile
Front screen material	PMMA

Table 31: Technical data for sender

	Minimum	Typical	Maximum
Wavelength of sender		Near-infrared (NIR), invisible	
Weight	Depending on the protective field height, see "Table of weights", page 86		
Laser alignment aid			
Wavelength		650 nm (red)	
Average output power			390 µW
Laser class	1		
Laser alignment aid switch input (In1)			
Input voltage HIGH (active)	13 V	24 V	30 V
Input current HIGH	2 mA	5 mA	7 mA
Input voltage LOW (deactivated)	-3 V	0 V	3 V
Input current LOW	-0.1 mA	0 mA	0.5 mA
Laser alignment aid pushbutton input (In2)			
Input voltage HIGH (active)	13 V	24 V	30 V
Input current HIGH	2 mA	5 mA	7 mA
Input voltage LOW (deactivated)	-3 V	0 V	3 V
Input current LOW	-0.1 mA	0 mA	0.5 mA
Control switch actuation time	50 ms		
Permissible cable resistance ¹⁾			
Supply cable ²⁾			2.5 Ω

- 1) Limit the individual conductor resistance to the specified values to ensure that the light curtain functions correctly. (Also observe IEC 60204-1.)
The specified values apply to the total resistance of each wire including contact and connector resistances.
- 2) If a T-connector is used, the specified values apply to the resistance of the entire cable from the system connection of the device to the connection in the control cabinet.

Table 32: Technical data for receiver

	Minimum	Typical	Maximum
Output signal switching devices (OSSDs)	2 PNP semiconductors, short-circuit protected ¹⁾ , cross-circuit monitored		
Response time	"Response time", page 84		
Duration of OFF state	100 ms		
Switch-on delay		3 × response time	
ON state, switching voltage HIGH (U_{rms}) ²⁾	$U_V - 2.25 V$	24 V	U_V
OFF state, switching voltage LOW ^{2) 3)}	0 V	0 V	2.0 V
Current-carrying capacity of the OSSDs			500 mA each
Leakage current of the OSSDs			2 mA each

	Minimum	Typical	Maximum
Load capacity			2.2 μ F
Load inductance			2.2 H
Test pulse data ⁴⁾			
Test pulse width		150 μ s	300 μ s
Test pulse rate	3 s ⁻¹	5 s ⁻¹	10 s ⁻¹
Discrepancy time (time offset between switching of OSSD2 and OSSD1)			1 ms
Inputs			
Input voltage HIGH (active) ²⁾	11 V	24 V	30 V
Input current HIGH	6 mA	10 mA	20 mA
Input voltage LOW (deactivated) ²⁾	-3 V	0 V	5 V
Input current LOW	-2.5 mA	0 mA	0.5 mA
External device monitoring input (EDM)			
Connected contactors			
Permissible dropout time			300 ms
Permissible pull in time			300 ms
Reset pushbutton input (RES)			
Control switch actuation time	50 ms		60 s
Application diagnostic output (ADO)	PNP semiconductor, short-circuit protected ¹⁾		
Output voltage HIGH (active)	$U_V - 3$ V		
Output voltage LOW (deactivated)		High resistance	
Output current HIGH (active)			100 mA
Permissible cable resistance ⁵⁾			
Supply cable ^{6) 7)}			1 Ω ⁸⁾
Cable between OSSD and load			2.5 Ω
All additional wires at the system connection and extension connection ⁶⁾			2.5 Ω

1) Applies to the voltage range between -30 V and +30 V.

2) According to IEC 61131-2.

3) The specified values are the switching voltage supplied by the safety light curtain. If higher voltages are implanted externally, the maximum value of 2.0 V can be exceeded.

4) When active, the outputs are tested cyclically (brief LOW). When selecting the downstream controllers, make sure that the test pulses do not result in deactivation when using the above parameters.

5) Limit the individual conductor resistance to the specified values to ensure that the light curtain functions correctly, particularly that a cross-circuit between the outputs is safely detected. (Also observe IEC 60204-1.)

The specified values apply to the total resistance of each wire including contact and connector resistances.

6) If a T-connector is used, the specified values apply to the resistance of the entire cable from the system connection of the device to the connection in the control cabinet.

7) The supply cable must not be used to connect other loads with the exception of the senders.

8) If a T-connector is used and the input current is greater than 1.2 A, the conductor resistance must not exceed 0.5 Ω .

Table 33: Operating data

	Minimum	Typical	Maximum
System connection	5-pin M12 male connector 8-pin M12 male connector		
Length of cable	200 mm		

	Minimum	Typical	Maximum
Cable diameter	5 mm		
Cable material of the system or extension connection	PUR		
Extension connection	Optional, female connector, M12, 5-pin		
Length of cable for connecting cables	"Length of cable", page 85		
Lengths of cable for other cables on the extension connection			10 m
Ambient operating temperature ^{1) 2) 3)}	-30 °C		+55 °C
Air humidity (non-condensing)	15%		95%
Storage temperature	-30 °C		+70 °C
Housing cross-section	31 mm × 34 mm, plus bracket, see "Dimensional drawings", page 86		
Vibration resistance ⁴⁾	5 ... 150 Hz, 3,5 mm / 1 g (EN 60068-2-6)		
Shock resistance ⁵⁾	15 g / 6 ms (EN 60068-2-27)		
Class	3M4 (IEC TR 60721-4-3)		
EMC	According to IEC 61496-1, IEC 61000-6-2, IEC 61000-6-4		

- 1) The temperature difference between sender and receiver must not exceed 25 K.
- 2) The cable belonging to the device incl. the associated connection plug must not be flexibly mounted under -25 °C.
- 3) Maximum ambient operating temperature over 1,000 m above sea level: +50 °C.
Maximum ambient operating temperature over 2,000 m above sea level: +45 °C.
- 4) Test conditions per axis: 1 octave/minute, 20 sweeps.
- 5) Test conditions per axis: 200 shocks.

13.2 Response time

Table 34: Response time for a single device

Protective field height in mm	Response time in ms	
	Uncoded	Code 1 or code 2
300	9	12
450	10	14
750	11	16

13.3 Power consumption

Table 35: Power consumption for sender and receiver

Protective field height in mm	Typical power consumption for sender in W	Typical power consumption for receiver in W ¹⁾
	Resolution 30 mm	Resolution 30 mm
300	1.23	3.23
450	1.31	3.30
750	1.45	3.43

- 1) Power discharged again via the OSSDs depending on the connected OSSD load must be added to the table values.

13.4 Length of cable

Table 36: Maximum lengths of cable for wire cross-section 0.34 mm², copper wire

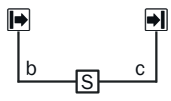
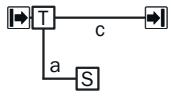
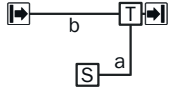
	Single system
Separate connecting cables for sender and receiver	 <p>$b \leq 50 \text{ m}$ $c \leq 15 \text{ m}$</p>
Connection of sender and receiver via T-connector on the sender	 <p>$a \leq 7 \text{ m}$ $c \leq 10 \text{ m}$</p>
Connection of sender and receiver via T-connector on the receiver	 <p>$a, b \leq 12 \text{ m}$</p>

S Control cabinet with safety relay or safety controller

T T-connector

Table 37: Maximum lengths of cable for wire cross-section 0.25 mm², copper wire

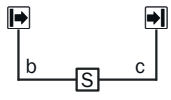
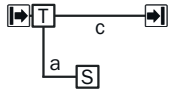
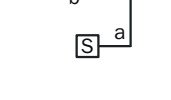
	Single system
Separate connecting cables for sender and receiver	 <p>$b \leq 35 \text{ m}$ $c \leq 12 \text{ m}$</p>
Connection of sender and receiver via T-connector on the sender	 <p>$a \leq 5 \text{ m}$ $c \leq 7 \text{ m}$</p>
Connection of sender and receiver via T-connector on the receiver	 <p>$a \leq 8 \text{ m}$ $b \leq 10 \text{ m}$</p>

S Control cabinet with safety relay or safety controller

T T-connector

13.5 Table of weights

Table 38: Weight of sender and receiver

Protective field height in mm	Weight in g ¹⁾	
	Sender	Receiver
300	230	240
450	370	380
750	640	650

1) Tolerance: ± 50 g.

13.6 Dimensional drawings

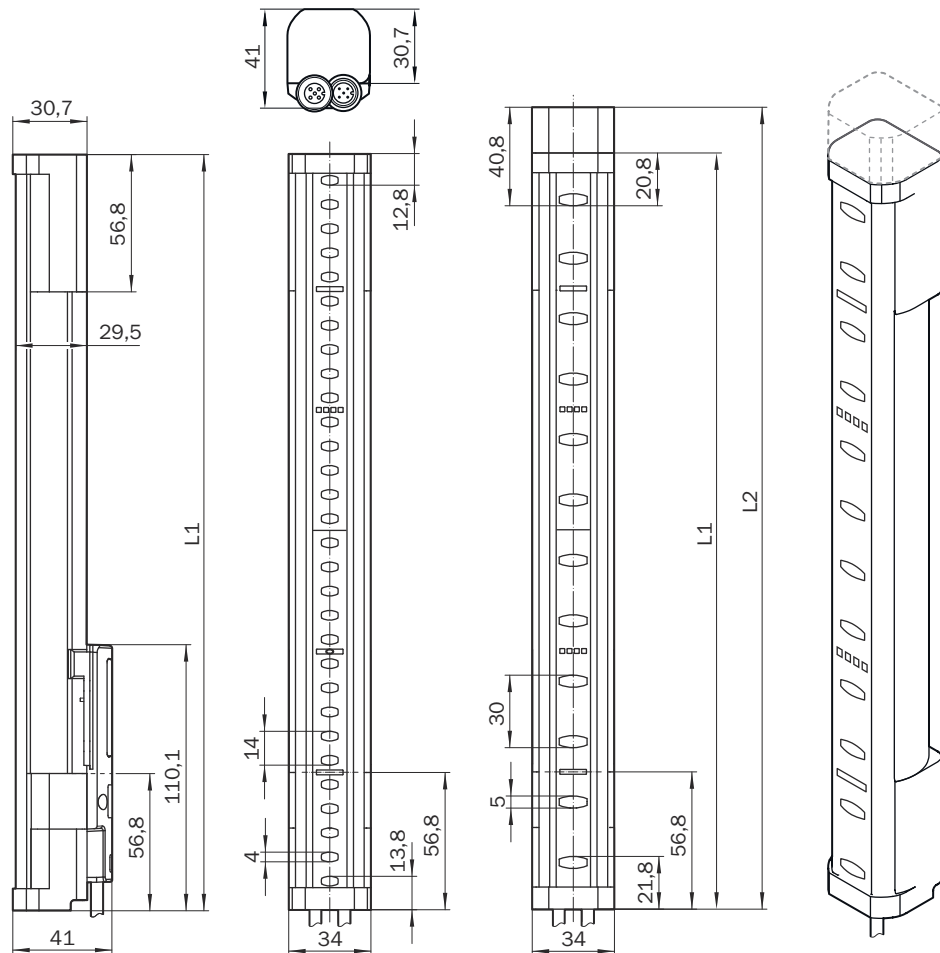

Figure 41: Dimensional drawing of sender and receiver

Table 39: Dimensions based on the protective field height, sender and receiver

Protective field height, nominal in mm	Protective field height, effective = dimension L1 in mm
300	313
450	463
750	763

14 Ordering information

14.1 Scope of delivery

Scope of delivery, sender

- Sender

Scope of delivery, receiver

- Receiver
- Test rod with diameter corresponding to the resolution of the safety light curtain
- Safety note
- Mounting instructions
- Operating instructions for download: www.sick.com

14.2 Ordering information

Table 40: SP1 system plug ordering information

Connection type	Type codes	Part number
System connection (M12, 5-pin)	1000	2076832
System connection (M12, 8-pin)	1200	2076834
System connection (M12, 5-pin) and extension connection (M12, 5-pin)	1100	2076833
System connection (M12, 8-pin) and extension connection (M12, 5-pin)	1300	2076835

Table 41: Ordering information deTec4 C4P-EAxxx3SC05 30 mm resolution

Protective field height in mm	Sender		Receiver	
	Part number	Type code	Part number	Type code
300	1220123	C4P-SA03031A00	1135911	C4P-EA0303SC05
450	1220124	C4P-SA04531A00	1135912	C4P-EA0453SC05
750	1220126	C4P-SA07531A00	1135913	C4P-EA0753SC05

15 Accessories

15.1 Brackets

Table 42: Brackets ordering information

Part	Type code	Part number
QuickFix bracket (2x)	BEF-3SHABPKU2	2066048
QuickFix bracket (4x)	BEF-3SHABPKU4	2098710
FlexFix bracket (2x)	BEF-1SHABPKU2	2098709
FlexFix bracket (4x)	BEF-1SHABPKU4	2066614
FlexFix mounting kit (2x FlexFix brackets, alignment tool, and assembly materials for installation in device columns)	BEF-1SHABBKU2	2073543
Replacement bracket (kit with 4 brackets, mounting kit for replacement of swivel mount brackets 2019649 and 2019659 or side bracket 2019506 with the FlexFix bracket when using the wells provided)	BEF-1SHABS004	2100345
Replacement bracket (kit with 4 brackets, mounting kit for replacement of swivel mount brackets 2030510 or side bracket 2019506 with the FlexFix bracket when using the wells provided)	BEF-1SHABU004	2099282

QuickFix bracket

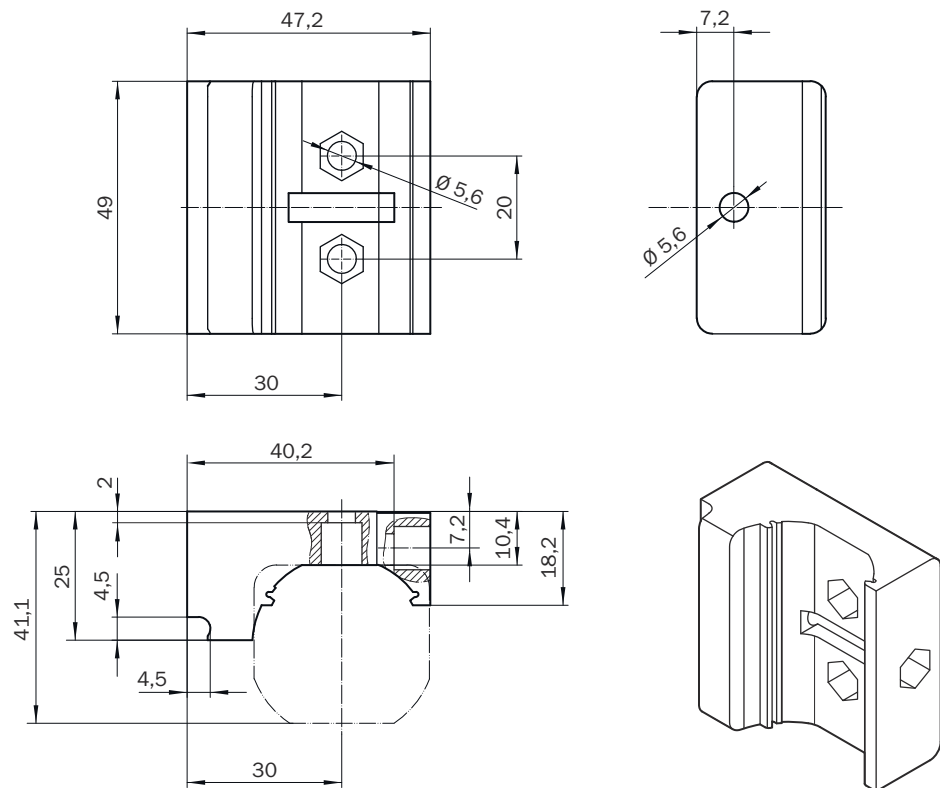

Figure 42: Dimensional drawing of the QuickFix bracket

FlexFix bracket

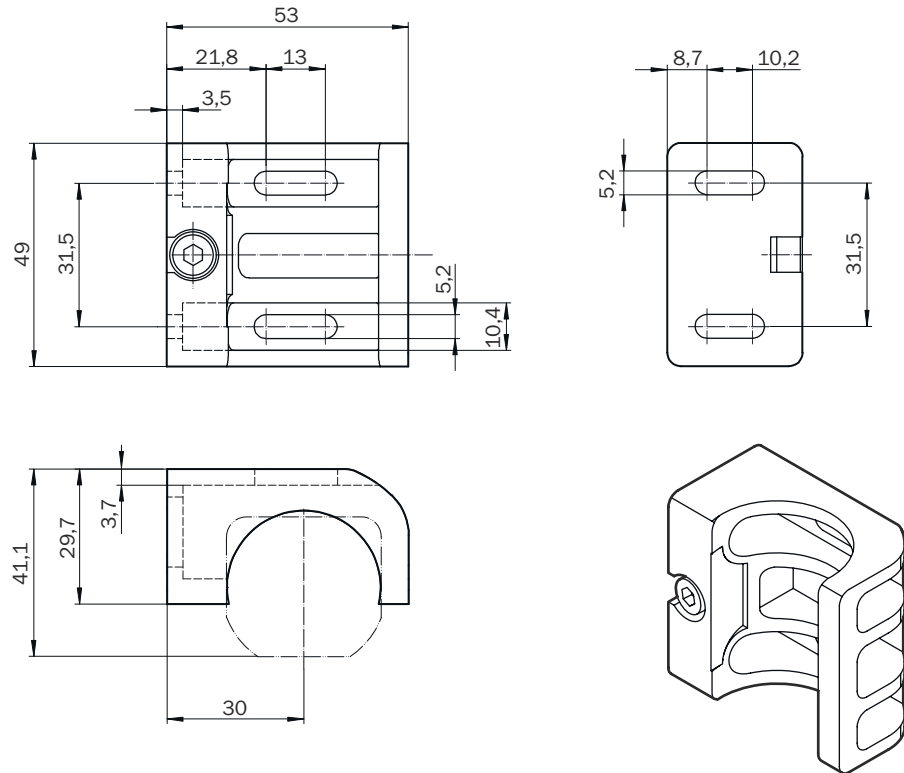

Figure 43: Dimensional drawing of the FlexFix bracket

15.2 Mounting accessories

Table 43: Mounting accessories ordering information

Part	Part number
Alignment tool	4084133

15.3 Weld spark guard

Overview

The weld spark guard can be used to protect the front screen of the safety light curtain. The weld spark guard reduces the scanning range of the system by 15%.

Important information



DANGER

Hazard due to lack of effectiveness of the protective device

The weld spark guard may influence the optical properties of the safety light curtain, leading to persons or body parts that should be protected being reflected and therefore remaining undetected.

- ▶ Make sure that all reflective surfaces and objects maintain the correct minimum distance from the protective field.

Differing minimum distance to reflective surfaces for devices with a resolution of 30 mm with weld spark guard

If a device with a resolution of 30 mm is used with the weld spark guard, the following applies in contrast to other specifications in order to determine the minimum distance from reflective surfaces:

1. Determine the distance D between sender and receiver in meters (m).
2. Read the minimum distance a in millimeters (mm) in the graph or calculate it based on the respective formula (see table 44).

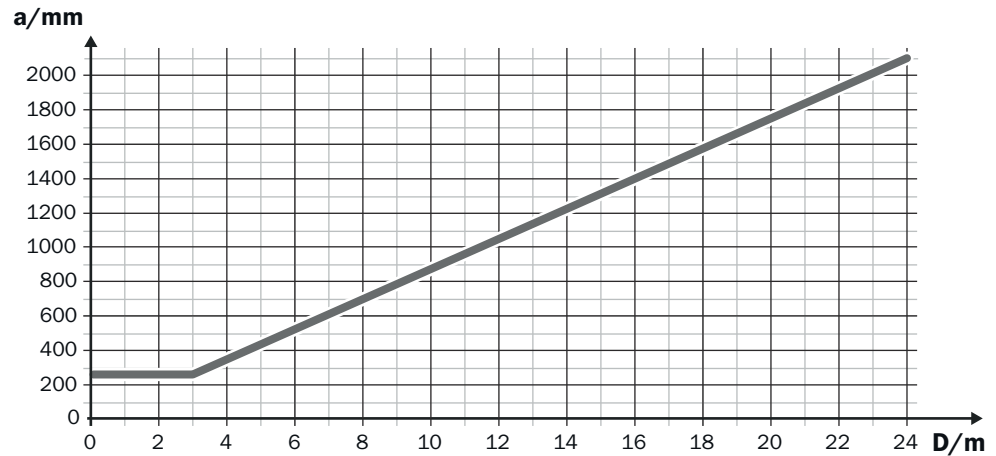

Figure 44: Diagram minimum distance to reflective surfaces for devices with a resolution of 30 mm with weld spark guard

Table 44: Formula for calculating the minimum distance to reflective surfaces for devices with a resolution of 30 mm with weld spark guard

Distance D between sender and receiver in m	Calculation of the minimum distance (a) from reflective surfaces in mm
$D \leq 3$ m	$a = 262$ mm
$D > 3$ m	$a = \tan(5^\circ) \times 1000 \text{ mm/m} \times D = 87,49 \times 1 \text{ mm/m} \times D$

Table 45: Weld spark guard ordering information

Part	Part number
Weld spark guard	2069268

Mounting

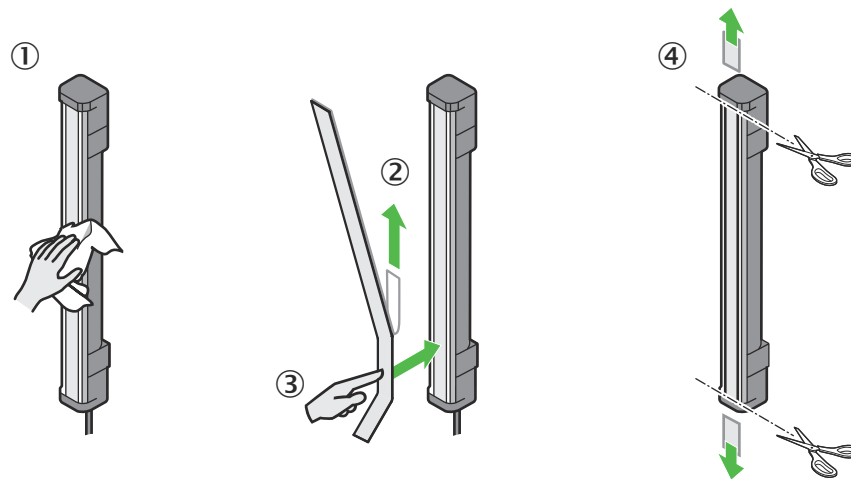

Figure 45: Mount the weld spark guard

- ① Clean the front screen
- ② Remove backing film
- ③ Press against the weld spark guard
- ④ Cut off excess ends

Further topics

- ["Minimum distance to reflective surfaces", page 25](#)

15.4 Connectors

Table 46: SP1 system plug ordering information

Connection type	Type codes	Part number
System connection (M12, 5-pin)	1000	2076832
System connection (M12, 8-pin)	1200	2076834
System connection (M12, 5-pin) and extension connection (M12, 5-pin)	1100	2076833
System connection (M12, 8-pin) and extension connection (M12, 5-pin)	1300	2076835

Table 47: Ordering information for M12 connecting cable, 5-pin (0.34 mm²)³⁾

Part	Type code	Part number
Female connector, straight, 2 m cable, flying leads	YF2A15-020UB5XLEAX	2095617
Female connector, straight, 5 m cable, flying leads	YF2A15-050UB5XLEAX	2095618
Female connector, straight, 10 m cable, flying leads	YF2A15-100UB5XLEAX	2095619
Female connector, straight, 15 m cable, flying leads	YF2A15-150UB5XLEAX	2095620
Female connector, straight, 20 m cable, flying leads	YF2A15-200UB5XLEAX	2095614
Female connector, straight, 30 m cable, flying leads	YF2A15-300UB5XLEAX	2095621

³⁾ Ambient operating temperature: Down to -30° C with fixed installation.

Part	Type code	Part number
Female connector, angled, 2 m cable, flying leads	YG2A15-020UB5XLEAX	2095772
Female connector, angled, 5 m cable, flying leads	YG2A15-050UB5XLEAX	2095773
Female connector, angled, 10 m cable, flying leads	YG2A15-100UB5XLEAX	2095774

Table 48: Ordering information for M12 connecting cable, 8-pin (0.25 mm²)⁴⁾

Part	Type code	Part number
Female connector, straight, 2 m cable, flying leads	YF2A18-020UA5XLEAX	2095652
Female connector, straight, 2.5 m cable, flying leads	YF2A18-025UA5XLEAX	2099229
Female connector, straight, 5 m cable, flying leads	YF2A18-050UA5XLEAX	2095653
Female connector, straight, 7.5 m cable, flying leads	YF2A18-075UA5XLEAX	2099230
Female connector, straight, 10 m cable, flying leads	YF2A18-100UA5XLEAX	2095654
Female connector, straight, 15 m cable, flying leads	YF2A18-150UA5XLEAX	2095679
Female connector, straight, 20 m cable, flying leads	YF2A18-200UA5XLEAX	2095680
Female connector, straight, 30 m cable, flying leads	YF2A18-300UA5XLEAX	2095681
Female connector, angled, 2 m cable, flying leads	YG2A18-020UA5XLEAX	2095779
Female connector, angled, 5 m cable, flying leads	YG2A18-050UA5XLEAX	2095780
Female connector, angled, 10 m cable, flying leads	YG2A18-100UA5XLEAX	2095781

Table 49: Ordering information for M12 connection cable, 5-pin (0.34 mm²)⁴⁾

Part	Type code	Part number
Female connector, straight, 0.6 m cable, male connector, straight	YF2A15-C60UB5M2A15	2096006
Female connector, straight, 1 m cable, male connector, straight	YF2A15-010UB5M2A15	2096007
Female connector, straight, 2 m cable, male connector, straight	YF2A15-020UB5M2A15	2096009
Female connector, straight, 5 m cable, male connector, straight	YF2A15-050UB5M2A15	2096010
Female connector, straight, 10 m cable, male connector, straight	YF2A15-100UB5M2A15	2096011
Female connector, straight, 15 m cable, male connector, straight	YF2A15-150UB5M2A15	2096171

Table 50: Ordering information for M12 connection cable, 8-pin (0.25 mm²)⁴⁾

Part	Type code	Part number
Female connector, straight, 0.6 m cable, straight male connector	YF2A18-C60UA5M2A18	2096031

4) Ambient operating temperature: Down to -30° C with fixed installation.

Part	Type code	Part number
Female connector, straight, 1 m cable, straight male connector	YF2A18-010UA5M2A18	2096032
Female connector, straight, 20 m cable, straight male connector	YF2A18-020UA5M2A18	2096033
Female connector, straight, 1 m cable, straight male connector	YF2A18-050UA5M2A18	2096034
Female connector, straight, 10 m cable, straight male connector	YF2A18-100UA5M2A18	2096035
Female connector, straight, 15 m cable, straight male connector	YF2A18-150UA5M2A18	2104374

Table 51: Ordering information for connection cable (replacement of C4000 with deTec4) ⁵⁾

Part	Type codes	Part number
M12 connection cable, 5-pin to M12, 5-pin	YF2A14-C20UB3M2A14	2096013
Connection cable, M12, 8-pin to M12, 8-pin	DSL-6108GM25034KM1	2034865
Connection cable M12 8-pin to M26, 7-pin	DSL-6130GM25034KM1	2081443
Connection cable M12 8-pin to M26, 12-pin	DSL-6129GM25034KM1	2081442
Connection cable M12 8-pin to M26, 12-pin	DSL-6129GM25034KM7	2112706

Table 52: Ordering information for distributor

Part	Type code	Part number
T distributor, 5-pin	DSC-1205T000025KM0	6030664
T distributor, 8-pin	DSC-1208T000025KM0	6058647
T-connector with pushbutton for laser alignment aid, M12, 5-pin		2077933

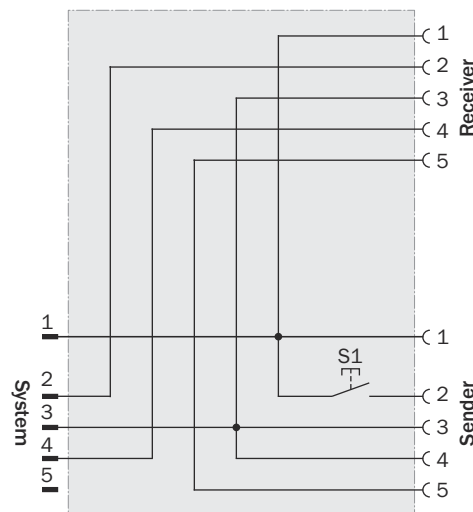

Figure 46: Internal circuitry: T-connector with pushbutton for laser alignment aid (5-pin)

Table 53: Ordering information for the connector

Part	Part number
IO-Link connector	2092757

⁵⁾ Ambient operating temperature: Down to -30° C with fixed installation.

Table 54: Connection modules ordering information

Part	Part number
SiLink2 master	1061790

Table 55: Sensor Integration Gateway ordering information

Part	Part number
SIG200 REST-API	1102605
SIG200 PROFINET	1089794
SIG200 Ethernet/IP	1089796

Table 56: Protective cap ordering information

Part	Part number
Protective cap, M12 for female connector	5310772

Table 57: Ordering information for power supply

Part	Type code	Part number
Output 24 V DC, 50 W (2.1 A), voltage supply NEC Class 2, SELV, PELV, input 120 V AC ... 240 V AC	PS50WE24V	7028789
Output 24 V DC, 95 W (3.9 A), voltage supply NEC Class 2, SELV, PELV, input 100 V AC ... 120 V / 220 V AC ... 240 V AC	PS95WE24V	7028790

Table 58: Ordering information for reset pushbutton

Part	Type code	Part number
Reset pushbutton, M12, 5-pin	ER12-SB3C5	6045316

Table 59: Ordering information for pushbutton

Part	Part number
Pushbutton for laser alignment aid, M12, 5-pin	2082166
Pushbutton for laser alignment aid, M12, 8-pin	2082167

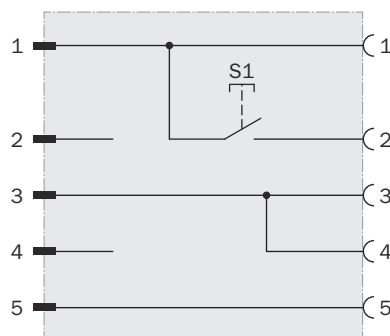

Figure 47: Internal circuitry: pushbutton for laser alignment aid (5-pin)

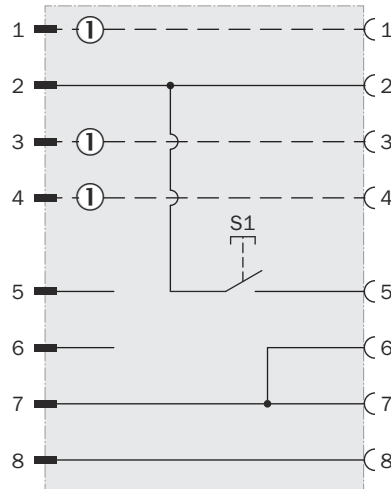

Figure 48: Internal circuitry: pushbutton for laser alignment aid (8-pin)

① Unused. The connection is not required but may be present.

15.5 Alignment aid

Table 60: Alignment aid ordering information

Part	Part number
AR60 laser alignment aid	1015741
Adapter	4070854

15.6 Deflector mirrors

15.6.1 Function and use

Overview

Deflector mirrors can be used to shape the protective field to secure hazardous points from multiple sides using a single safety light curtain.

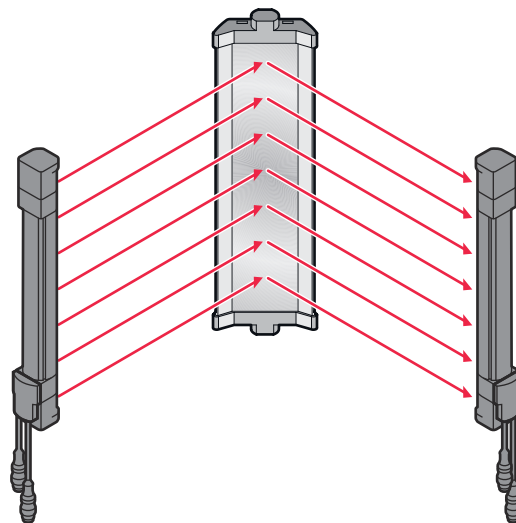

Figure 49: Example of use of deflector mirrors

Important information



DANGER

Hazard due to lack of effectiveness of the protective device

Persons and parts of the body to be protected may not be recognized in case of non-observance.

- ▶ Only mount deflector mirrors to solid walls or machine components. The position of the deflector mirrors must not change after alignment.
- ▶ Do not use deflector mirrors if contamination, beading water, condensation, or frost on the deflector mirrors is to be expected.
- ▶ Make sure that the deflector mirrors are intact and free of scratches, contamination, beading water, condensation, frost, etc. at all times.

Further topics

- ["Mirror columns", page 97](#)

15.6.2 Mounting

To mount the deflector mirrors, use the included swivel mount brackets.

15.6.3 Change in scanning range using deflector mirrors

Important information



NOTE

The use of deflector mirrors reduces the scanning range depending on the number of deflector mirrors in the protective field.

Table 61: Scanning range with and without 1 or 2 deflector mirrors

Type	Solution	Scanning range, typical	Scanning range with 1 deflector mirror, typical	Scanning range with 2 deflector mirrors, typical
PNS75, PNS125	30 mm	30 m	$D1 + D2 \leq 27 \text{ m}$	$D1 + D2 + D3 \leq 24.3 \text{ m}$

15.6.4 Deflector mirror PNS75 - ordering information

Table 62: Ordering information for PNS75 deflector mirror

Mirror length in mm	Max. protective field height in mm	Type code	Part number
340	300	PNS75-034	1019414
490	450	PNS75-049	1019415
790	750	PNS75-079	1019417

15.6.5 Deflector mirror PNS125 - ordering information

Table 63: Ordering information, deflector mirror PNS125

Mirror length in mm	Max. protective field height in mm	Type code	Part number
340	300	PNS125-034	1019425
490	450	PNS125-049	1019426
790	750	PNS125-079	1019428

15.7 Mirror columns

Table 64: Ordering information, mirror columns

Column height	Mirror length	Type code	Part number
1,281.5 mm	1,082 mm	PM3C13-00030000	1043453
1,569 mm	1,382 mm	PM3C15-00030000	1077525
1,716.5 mm	1,532 mm	PM3C17-00030000	1043454
2,016.5 mm	1,682 mm	PM3C19-00030000	1043455
2,216.5 mm	1,832 mm	PM3C20-00030000	1043456
2,269 mm	1,985 mm	PM3C22-00030000	1093216
2,419 mm	2,132 mm	PM3C24-00030000	1093217

Complementary information

Observe the information on deflector mirrors, particularly on changing the scanning range.

Further topics

- ["Deflector mirrors", page 95](#)

15.8 Device columns

Table 65: Ordering information for device columns

Column height	Max. installation length	Type code	Part number
985 mm	965 mm	PU3H96-00000000	2045490
1185 mm	1165 mm	PU3H11-00000000	2045641
1285 mm	1265 mm	PU3H13-00000000	2045642
1570 mm	1550 mm	PU3H15-00000000	2068813
1740 mm	1720 mm	PU3H17-00000000	2045643
2040 mm	2020 mm	PU3H21-00000000	2045644
2270 mm	2250 mm	PU3H22-00000000	2045645
2420 mm	2400 mm	PU3H24-00000000	2045646

15.9 Cleaning agent

Table 66: Cleaning agent ordering information

Part	Part number
Anti-static plastic cleaner	5600006
Lens cloth	4003353

15.10 Test rods

Table 67: Ordering information, test rods

Part	Part number
Test rod 30 mm	2022602
Test rod holder	2052249

16 Annex

16.1 Conformities and certificates

You can obtain declarations of conformity, certificates, and the current operating instructions for the product at www.sick.com. To do so, enter the product part number in the search field (part number: see the entry in the “P/N” or “Ident. no.” field on the type label).

16.1.1 EU declaration of conformity

Excerpt

The undersigned, representing the manufacturer, herewith declares that the product is in conformity with the provisions of the following EU directive(s) (including all applicable amendments), and that the standards and/or technical specifications stated in the EU declaration of conformity have been used as a basis for this.

16.2 Note on standards

Standards are specified in the information provided by SICK. The table shows regional standards with similar or identical contents. Not every standard applies to all products.

Table 68: Note on standards

Standard	Standard (regional)
	China
IEC 60068-2-6	GB/T 2423.10
IEC 60068-2-27	GB/T 2423.5
IEC 60204-1	GB/T 5226.1
IEC 60529	GB/T 4208
IEC 60825-1	GB 7247.1
IEC 61131-2	GB/T 15969.2
IEC 61140	GB/T 17045
IEC 61496-1	GB/T 19436.1
IEC 61496-2	GB/T 19436.2
IEC 61496-3	GB 19436.3
IEC 61508	GB/T 20438
IEC 62061	GB 28526
ISO 13849-1	GB/T 16855.1
ISO 13855	GB/T 19876

16.3 Checklist for initial commissioning and commissioning

Checklist for manufacturers or installers for installing electro-sensitive protective device (ESPE)

The details relating to the items listed below must be available no later than when the system is commissioned for the first time. However, these depend on the specific application (the requirements of which must be reviewed by the manufacturer or installer).

This checklist should be retained and kept with the machine documentation to serve as reference during recurring tests.

This checklist does not replace the initial commissioning, nor the regular inspection by qualified safety personnel.

Have the safety rules and regulations been observed in compliance with the directives and standards applicable to the machine?	Yes <input type="checkbox"/> No <input type="checkbox"/>
Are the applied directives and standards listed in the declaration of conformity?	Yes <input type="checkbox"/> No <input type="checkbox"/>
Does the protective device correspond to the required PL/SIL and PFHd in accordance with ISO 13849-1 / IEC 62061 and the required type in accordance with IEC 61496-1?	Yes <input type="checkbox"/> No <input type="checkbox"/>
Is access to the hazardous area or hazardous point only possible through the protective field of the ESPE?	Yes <input type="checkbox"/> No <input type="checkbox"/>
Have appropriate measures been taken to protect (mechanical protection) or monitor (protective devices) any persons or objects in the hazardous area when protecting a hazardous area or hazardous point, and have these devices been secured or locked to prevent their removal?	Yes <input type="checkbox"/> No <input type="checkbox"/>
Are additional mechanical protective measures fitted and secured against manipulation which prevent reaching below, above or around the ESPE?	Yes <input type="checkbox"/> No <input type="checkbox"/>
Has the maximum shutdown and/or stopping time of the machine been measured, specified and documented (at the machine and/or in the machine documentation)?	Yes <input type="checkbox"/> No <input type="checkbox"/>
Has the ESPE been mounted such that the required minimum distance from the nearest hazardous point has been achieved?	Yes <input type="checkbox"/> No <input type="checkbox"/>
Are the ESPE devices properly mounted and secured against manipulation after alignment?	Yes <input type="checkbox"/> No <input type="checkbox"/>
Are the required protective measures against electric shock in effect (protection class)?	Yes <input type="checkbox"/> No <input type="checkbox"/>
Is the control switch for resetting the protective devices (ESPE) or restarting the machine present and correctly installed?	Yes <input type="checkbox"/> No <input type="checkbox"/>
Are the outputs of the ESPE (OSSDs or safety outputs via the network) integrated according to the required PL/SIL in accordance with ISO 13849-1 / IEC 62061 and does the integration correspond to the circuit diagrams?	Yes <input type="checkbox"/> No <input type="checkbox"/>
Has the protective function been checked in compliance with the test notes of this documentation?	Yes <input type="checkbox"/> No <input type="checkbox"/>
Are the specified protective functions effective at every operating mode that can be set?	Yes <input type="checkbox"/> No <input type="checkbox"/>
Are the switching elements activated by the ESPE, e.g. contactors, valves, monitored?	Yes <input type="checkbox"/> No <input type="checkbox"/>
Is the ESPE effective over the entire period of the dangerous state?	Yes <input type="checkbox"/> No <input type="checkbox"/>
Once initiated, will a dangerous state be stopped when switching the ESPE on or off and when changing the operating mode, or when switching to another protective device?	Yes <input type="checkbox"/> No <input type="checkbox"/>

17 List of figures

1.	Laser class 1.....	9
2.	Sender and receiver.....	12
3.	Device overview.....	13
4.	NFC symbol	15
5.	Sender displays.....	17
6.	Receiver displays.....	18
7.	Access protection.....	20
8.	Minimum distance to the hazardous point for orthogonal (rectangular) approach to the protective field.....	24
9.	Representation of the accessibility of ESPE by reaching over. Left: Protective field that cannot be reached over. Right: Protective field that can be reached over.....	25
10.	Minimum distance from reflective surfaces.....	26
11.	Graph of minimum distance from reflective surfaces.....	26
12.	Preventing mutual interference from system ① and system ②.....	27
13.	Trouble-free operation due to beam coding.....	28
14.	Trouble-free operation due to reversed direction of transmission of system ① and system ②.....	29
15.	Trouble-free operation of 4 neighboring systems due to beam coding and reversed direction of transmission.....	29
16.	Dual-channel and isolated connection of OSSD1 and OSSD2.....	30
17.	No potential difference between load and protective device.....	31
18.	Schematic representation of operation with restart interlock.....	32
19.	Electrical diagram of the reset device.....	33
20.	Electrical diagram of external device monitoring (EDM).....	34
21.	Electrical diagram of the application diagnostic output.....	34
22.	Switch for the integrated laser alignment aid.....	36
23.	Test rod check: Step 1.....	39
24.	Test rod check: Step 3.....	39
25.	Mounting the system plug.....	42
26.	Sender and receiver must not be installed such that they are rotated 180° relative to each other.....	43
27.	Mounting the QuickFix bracket to a profile.....	47
28.	Mounting the FlexFix bracket to a profile frame.....	48
29.	Inserting the safety light curtain in the FlexFix brackets.....	49
30.	Mounting the FlexFix bracket to a device column (accessory).....	50
31.	Dual-channel and isolated connection of OSSD1 and OSSD2.....	52
32.	No potential difference between load and protective device.....	52
33.	System connection (male connector, M12, 5-pin).....	52
34.	System connection (male connector M12, 8-pin).....	53
35.	Extension connection (female connector M12, 5-pin).....	54
36.	SP1 system plug with 2 DIP switches.....	55
37.	Reset to factory settings.....	56
38.	Configuring beam coding.....	57
39.	QuickFix bracket: adjust vertically.....	64
40.	FlexFix bracket: adjust vertically/rotate.....	65
41.	Dimensional drawing of sender and receiver.....	86
42.	Dimensional drawing of the QuickFix bracket.....	88
43.	Dimensional drawing of the FlexFix bracket.....	89
44.	Diagram minimum distance to reflective surfaces for devices with a resolution of 30 mm with weld spark guard.....	90
45.	Mount the weld spark guard.....	91
46.	Internal circuitry: T-connector with pushbutton for laser alignment aid (5-pin).....	93
47.	Internal circuitry: pushbutton for laser alignment aid (5-pin).....	94
48.	Internal circuitry: pushbutton for laser alignment aid (8-pin).....	95

49. Example of use of deflector mirrors..... 95

18 List of tables

1.	Available documents.....	7
2.	Target groups and selected sections of these operating instructions.....	7
3.	Use of SP1 system plug in a single system.....	16
4.	Colors and their meaning.....	18
5.	Indication of the configuration status.....	19
6.	Indication of the alignment quality.....	19
7.	Fault indicator.....	19
8.	Warnings.....	19
9.	Formula for calculating the minimum distance to reflective surfaces with automatic calibration of the protective field width.....	26
10.	Side and rear mounting with the QuickFix bracket.....	46
11.	Lateral and rear mounting with the FlexFix bracket.....	48
12.	System connection pin assignment (male connector, M12, 5-pin).....	53
13.	System connection pin assignment for SP1 system plug (M12 male connector, 8-pin).....	53
14.	SP1 system plug extension connection pin assignment (M12 female connector, 5-pin).....	54
15.	Functions and their configuration type.....	55
16.	Overview of DIP switches.....	55
17.	Configurable functions when delivered.....	55
18.	Configuration mode.....	57
19.	DIP switches and beam coding.....	57
20.	Output signals on the system connection and extension connection.....	60
21.	Indication of the alignment quality.....	66
22.	LEDs on the receiver during normal operation.....	67
23.	Indications on the sender when switching on.....	73
24.	Indications on the receiver when switching on.....	73
25.	Indication of the alignment quality.....	74
26.	LEDs on the receiver during normal operation.....	75
27.	Fault indication on the sender.....	76
28.	Fault indication on the receiver.....	77
29.	General system data.....	81
30.	Mechanical data.....	82
31.	Technical data for sender.....	82
32.	Technical data for receiver.....	82
33.	Operating data.....	83
34.	Response time for a single device.....	84
35.	Power consumption for sender and receiver.....	84
36.	Maximum lengths of cable for wire cross-section 0.34 mm ² , copper wire.....	85
37.	Maximum lengths of cable for wire cross-section 0.25 mm ² , copper wire.....	85
38.	Weight of sender and receiver	86
39.	Dimensions based on the protective field height, sender and receiver.....	86
40.	SP1 system plug ordering information.....	87
41.	Ordering information deTec4 C4P-EAxx3SC05 30 mm resolution.....	87
42.	Brackets ordering information.....	88
43.	Mounting accessories ordering information.....	89
44.	Formula for calculating the minimum distance to reflective surfaces for devices with a resolution of 30 mm with weld spark guard.....	90
45.	Weld spark guard ordering information.....	90
46.	SP1 system plug ordering information.....	91
47.	Ordering information for M12 connecting cable, 5-pin (0.34 mm ²)	91
48.	Ordering information for M12 connecting cable, 8-pin (0.25 mm ²)	92
49.	Ordering information for M12 connection cable, 5-pin (0.34 mm ²)	92
50.	Ordering information for M12 connection cable, 8-pin (0.25 mm ²)	92

51. Ordering information for connection cable (replacement of C4000 with deTec4)	93
52. Ordering information for distributor.....	93
53. Ordering information for the connector.....	93
54. Connection modules ordering information.....	94
55. Sensor Integration Gateway ordering information.....	94
56. Protective cap ordering information.....	94
57. Ordering information for power supply.....	94
58. Ordering information for reset pushbutton.....	94
59. Ordering information for pushbutton.....	94
60. Alignment aid ordering information.....	95
61. Scanning range with and without 1 or 2 deflector mirrors.....	96
62. Ordering information for PNS75 deflector mirror.....	96
63. Ordering information, deflector mirror PNS125.....	96
64. Ordering information, mirror columns.....	97
65. Ordering information for device columns.....	97
66. Cleaning agent ordering information.....	97
67. Ordering information, test rods.....	97
68. Note on standards.....	98

Australia

Phone +61 (3) 9457 0600
1800 33 48 02 – tollfree
E-Mail sales@sick.com.au

Austria

Phone +43 (0) 2236 62288-0
E-Mail office@sick.at

Belgium/Luxembourg

Phone +32 (0) 2 466 55 66
E-Mail info@sick.be

Brazil

Phone +55 11 3215-4900
E-Mail comercial@sick.com.br

Canada

Phone +1 905.771.1444
E-Mail cs.canada@sick.com

Czech Republic

Phone +420 234 719 500
E-Mail sick@sick.cz

Chile

Phone +56 (2) 2274 7430
E-Mail chile@sick.com

China

Phone +86 20 2882 3600
E-Mail info.china@sick.net.cn

Denmark

Phone +45 45 82 64 00
E-Mail sick@sick.dk

Finland

Phone +358-9-25 15 800
E-Mail sick@sick.fi

France

Phone +33 1 64 62 35 00
E-Mail info@sick.fr

Germany

Phone +49 (0) 2 11 53 010
E-Mail info@sick.de

Greece

Phone +30 210 6825100
E-Mail office@sick.com.gr

Hong Kong

Phone +852 2153 6300
E-Mail ghk@sick.com.hk

Hungary

Phone +36 1 371 2680
E-Mail ertekesites@sick.hu

India

Phone +91-22-6119 8900
E-Mail info@sick-india.com

Israel

Phone +972 97110 11
E-Mail info@sick-sensors.com

Italy

Phone +39 02 27 43 41
E-Mail info@sick.it

Japan

Phone +81 3 5309 2112
E-Mail support@sick.jp

Malaysia

Phone +603-8080 7425
E-Mail enquiry.my@sick.com

Mexico

Phone +52 (472) 748 9451
E-Mail mexico@sick.com

Netherlands

Phone +31 (0) 30 229 25 44
E-Mail info@sick.nl

New Zealand

Phone +64 9 415 0459
0800 222 278 – tollfree
E-Mail sales@sick.co.nz

Norway

Phone +47 67 81 50 00
E-Mail sick@sick.no

Poland

Phone +48 22 539 41 00
E-Mail info@sick.pl

Romania

Phone +40 356-17 11 20
E-Mail office@sick.ro

Russia

Phone +7 495 283 09 90
E-Mail info@sick.ru

Singapore

Phone +65 6744 3732
E-Mail sales.gsg@sick.com

Slovakia

Phone +421 482 901 201
E-Mail mail@sick-sk.sk

Slovenia

Phone +386 591 78849
E-Mail office@sick.si

South Africa

Phone +27 10 060 0550
E-Mail info@sickautomation.co.za

South Korea

Phone +82 2 786 6321/4
E-Mail infokorea@sick.com

Spain

Phone +34 93 480 31 00
E-Mail info@sick.es

Sweden

Phone +46 10 110 10 00
E-Mail info@sick.se

Switzerland

Phone +41 41 619 29 39
E-Mail contact@sick.ch

Taiwan

Phone +886-2-2375-6288
E-Mail sales@sick.com.tw

Thailand

Phone +66 2 645 0009
E-Mail marcom.th@sick.com

Turkey

Phone +90 (216) 528 50 00
E-Mail info@sick.com.tr

United Arab Emirates

Phone +971 (0) 4 88 65 878
E-Mail contact@sick.ae

United Kingdom

Phone +44 (0)17278 31121
E-Mail info@sick.co.uk

USA

Phone +1 800.325.7425
E-Mail info@sick.com

Vietnam

Phone +65 6744 3732
E-Mail sales.gsg@sick.com

Detailed addresses and further locations at www.sick.com

