

# DiCoder® CKS36: Programmable Motor Feedback System for Installation in Electric Motors

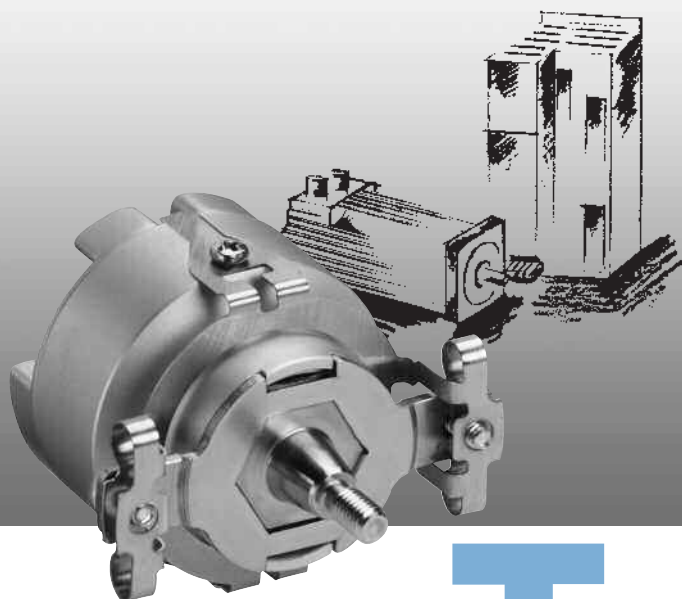

In doing so, the system compensates for the eccentricity errors of the code disc, ball bearing and shaft, which are unavoidable in conventional systems.

By arranging the code disc in the centre of the rotational axis, high angular velocities are no longer limited by the code disc. The encoder size is essentially determined by the mechanical and electrical interfaces. Technologies such as "Chip On Board" are used to achieve this. The number of components is reduced to a minimum.

Incremental signals with resolutions of up to 2,048 lines per revolution and commutation signals of up to 32 pole pairs are available. A freely user-programmable version is also available.

	<b>Number of lines up to 2,048, 1-32 pole pairs</b>
<b>Motor Feedback Systems</b>	

**T**he CKS36 Encoder belongs to a new generation of optical encoders.

What they all have in common is the new mini-disc (MiDi) technology.

This generation has a special feature: a very small code disc with a code track radius of only 2 mm permitting holistic (integral) scanning and at the same time providing high shock and vibration resistance.

**Number of lines up to 2,048, 1-32 pole pairs**

Motor Feedback Systems

- Resolution up to 2,048 Pulses per revolution
- Number of pole pairs: from 1 to 32
- Zero pulse 90° or 180°
- Working temperature range - 20°C to + 110 °C
- Programmable

### Dimensional drawing CKS36

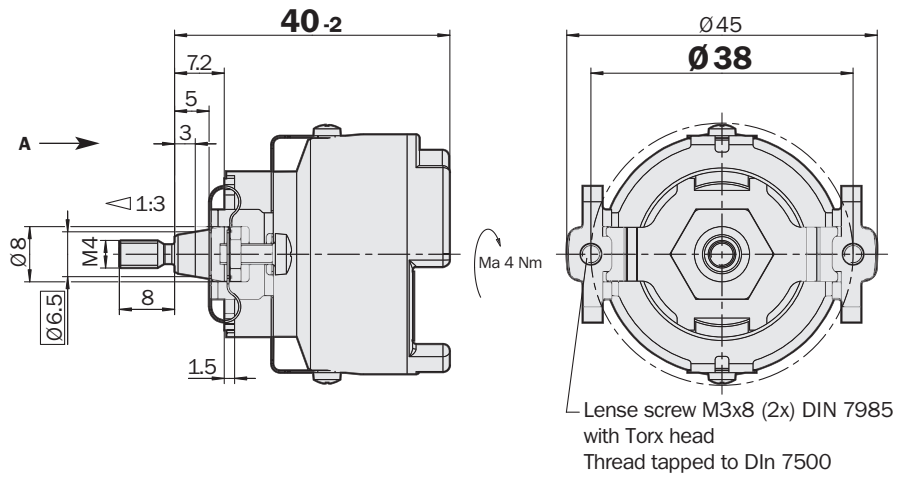

### Proposed customer fitting

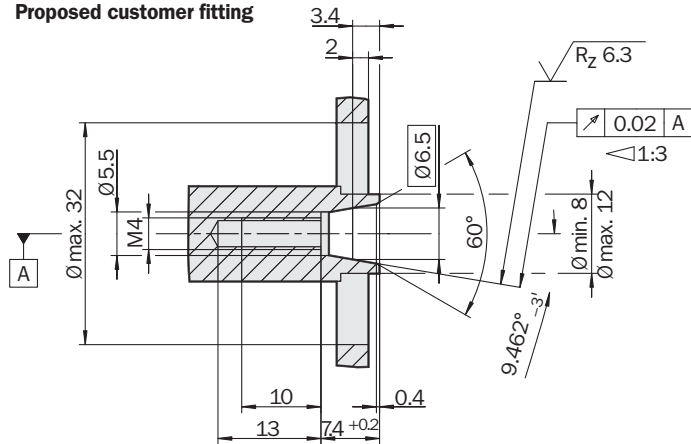

General tolerances to DIN ISO 2768-mk

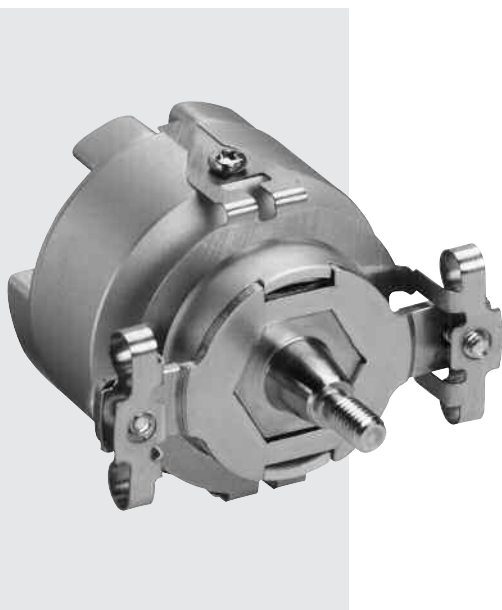

### PIN and core allocation

PIN	Signal	Colour of cores	Explanation
1	Z	violet	Reference signal
2	Z̄	yellow	Reference signal inverted
3	A	white	Incremental signal
4	Ā	brown	Incremental signal inverted
5	B	pink	Incremental signal
6	B̄	black	Incremental signal inverted
7	R	white/green	Commutation signal
8	R̄	white/pink	Commutation signal inverted
9	S	white/yellow	Commutation signal
10	S̄	white/blue	Commutation signal inverted
11	T	white/grey	Commutation signal
12	T̄	white/red	Commutation signal inverted
13	U <sub>s</sub>	red	Supply voltage 5 V ± 10%
14	GND	blue	Ground connection
15	U <sub>s</sub>	-	Sense + <sup>1)</sup>
16	GND	-	Sense - <sup>1)</sup>
17	N. C.	-	Not connected <sup>1)</sup>
18	SET	-	Signal input for zero adjustment <b>1</b> All output signals are adjusted to the position of the zero pulse. A level of > 2.5 V ≤ U <sub>s</sub> must be maintained for at least 220 μs in order to execute this function. <sup>1)</sup>
19	SDA	-	Data signal of the parameterisation interface <sup>1)</sup>
20	SCL	-	Clock pulse signal of the parameterisation interface <sup>1)</sup>

**1** Electrical zero adjustment

<sup>1)</sup> (not in stranded cable)

Caution: Pins labelled N. C. must not be occupied!

Accessories
Connection technology
Fixing technology
Programming and Adjustment Tool

Technical data to DIN 32878		CKS36	CKS									
<b>Lines per revolution</b>		1 ... 2,048										
<b>Commutation signales</b>		1 ... 32 pole pairs										
<b>Dimensions</b>		mm (see dimensional drawing)										
<b>Mass</b>		0.065 kg										
<b>Moment of inertia of the rotor</b>		4.5 gcm <sup>2</sup>										
<b>Measurement step</b>		90°/number of lines										
<b>Reference signal</b>	Number	1										
	Position	configurable 90° or 180° electr., logically linked with A and B										
<b>Error limits</b>												
	„binary“ number of lines <sup>1)</sup>	± 0.09 degrees										
	„non-binary“ number of lines <sup>2)</sup>	± 0.13 degrees										
<b>Measurement step deviation</b>												
	„binary“ number of lines <sup>1)</sup>	± 0.035 degrees										
	„non-binary“ number of lines <sup>2)</sup>	± 0.07 degrees										
	<b>Operating speed</b> <sup>3) + 3.1)</sup>	12,000 min <sup>-1</sup>										
	<b>Max. output fequency</b> TTL/RS 422	400 KHz										
	<b>Max. angular acceleration</b>	5 x 10 <sup>5</sup> rad/s <sup>2</sup>										
	<b>Operating torque</b>	0.2 Ncm										
	<b>Starting torque</b>	0.3 Ncm										
<b>Permissible shaft movement</b>												
	static	radial/axial	± 0.1 mm/± 0.2 mm									
	dynamic	radial/axial	± 0.05 mm/± 0.1 mm									
	<b>Bearing lifetime</b>		3.6 x 10 <sup>9</sup> revolutions									
	<b>Working temperature range</b>		-20 ... + 110 °C									
	<b>Storage temperature range</b> <sup>4)</sup>		- 40 ... + 125 °C									
	<b>Permissible relative humidity</b> <sup>5)</sup>		90 %									
<b>Resistance</b>												
	to shocks <sup>6)</sup>		100 g (6 ms)									
	to vibration <sup>7)</sup>		50 g (10 ... 2000 Hz)									
	<b>Protection class acc. IEC 60529</b> <sup>8)</sup>		IP 50									
<b>EMC</b> <sup>9)</sup>												
	<b>Operating voltage range</b>		5 V ± 10 %									
	<b>Max. operating current, no load</b>		60 mA									
<b>Interface signals:</b>												
	Incremental and commutation signals		to EIA 422									
	Parameterisation interface		IIC Bus									

<sup>1)</sup> „Binary“ number of lines  
2<sup>n</sup>, n is a whole number

<sup>2)</sup> „Non binary“ number of lines  
2<sup>n</sup>, n is not a whole number

<sup>3)</sup> In the case of a higher speed, the output signals may be incorrect.

<sup>3.1)</sup> Self warming 1,1K/1000 min<sup>-1</sup>  
when applying, note working temperature range.

<sup>4)</sup> Without packaging

<sup>5)</sup> Condensation not permissible

<sup>6)</sup> To DIN EN 60068-2-27

<sup>7)</sup> To DIN EN 60068-2-6

<sup>8)</sup> With mating connector inserted and closed cover

<sup>9)</sup> To DIN EN 61000-6-2 and DIN 61000-6-3

The EMC according to the standards quoted is achieved when the motor feedback system is mounted in an electrically conductive housing, which is connected to the central earthing point of the motor controller via a cable screen. This is also where the GND (0 V) connection of the supply voltage is linked to earth.

Users must perform their own tests when other screen designs are used.

## Incremental signals

At constant speed, looking at the input shaft, and clockwise rotation.

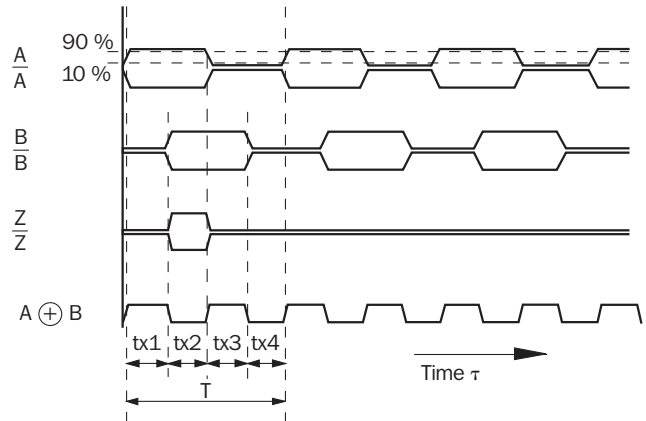

By linking the two signals A and B, an output signal is created whose cycle durations  $tx_1 \dots tx_4$  have different sizes.

1. by the mark/space ratio tolerance of the individual channels
2. by the tolerance in the  $90^\circ$  phase shift between A and B
3. by the frequency

The differences are determined:

1. by the mark/space ratio tolerance of the individual channels
  2. by the tolerance in the  $90^\circ$  phase shift between A and B
  3. by the frequency
- Ideally, the times  $tx_1 \dots tx_4$  should always be  $1/4$  of the cycle duration T.

## Pulse-time diagram

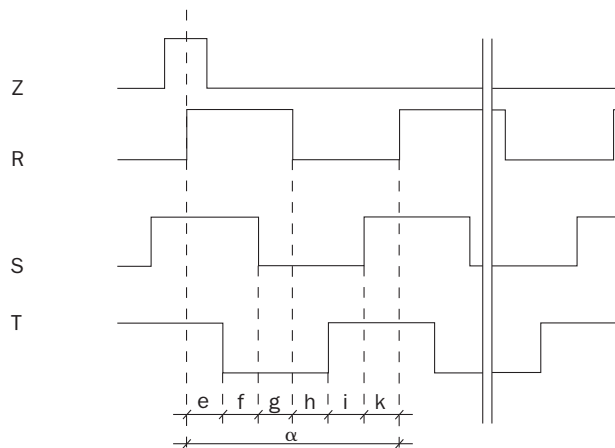

Pole pairs	Number of poles	e, f, g, h, i, k	$\alpha$
Example: 2	4	$30^\circ$	$180^\circ$
n	$n \cdot 2$	$360^\circ/6n$	$360^\circ/n$

$n = 1 \dots 32$

The angular data is related to a mechanical shaft rotation.

Precision of the signals R, S, T  $\pm 1^\circ$ .

## Programmable version of the CKS36 (type: CKS36-PFBPROGR; part no. 1035370)

This product option of the CKS36 can be freely programmed by the user. With the programming and adjustment tool (PGT-06-S), the following values can be individually programmed.

	Adjustable values	Default settings
Zero puls width	$90^\circ$ or $180^\circ$	$90^\circ$
Number of pole pairs	1 to 32	32
Number of lines	1 to 2,048	2,048

### Caution!

In the case of CKS36 ordered with fixed defined values (e. g.  $90^\circ$  zero pulse width,

1,024 lines, 4 pole pairs), these parameters can not be modified.

**Ordering information CKS36**

**Motor Feedback System CKS36 – freely programmable**

Type	Part no.	Description
CKS36-PFBPROGR	1035370	Motor Feedback System CKS36 – programmable

**Delivery settings:**

90° zero pulse width, 2,048 lines, 32 pole pairs

**Motor Feedback System CKS36 – fixed defined values (these values cannot be modified by the user)**

Position 1	Position 2	Position 3	Position 4	Position 5	Position 6	Position 7	Position 8	Position 9	Position 10	Position 11	Position 12	Position 13	Position 14
<b>C</b>	<b>K</b>	<b>S</b>	<b>3</b>	<b>6</b>	<b>-</b>		<b>F</b>	<b>B</b>					

Electrical interfaces	
5 V, RS 422, 90° zero pulse width	= <b>A</b>
5 V, RS 422, 180° zero pulse width	= <b>B</b>

Lines per revolution		Pole pairs	
128	= <b>080</b>	1 pole pair	= <b>01</b>
256	= <b>100</b>	2 pole pairs	= <b>02</b>
512	= <b>200</b>	3 pole pairs	= <b>03</b>
1024	= <b>400</b>	4 pole pairs	= <b>04</b>
2048	= <b>800</b>	6 pole pairs	= <b>06</b>
500	= <b>1F4</b>	8 pole pairs	= <b>08</b>
1000	= <b>3E8</b>	10 pole pairs	= <b>10</b>
2000	= <b>7D0</b>	12 pole pairs	= <b>12</b>
		16 pole pairs	= <b>16</b>

**Ordering example: Motor Feedback System CKS36**

90° zero pulse width, 2,048 number of lines, 4 pole pairs

Position 1	Position 2	Position 3	Position 4	Position 5	Position 6	Position 7	Position 8	Position 9	Position 10	Position 11	Position 12	Position 13	Position 14
<b>C</b>	<b>K</b>	<b>S</b>	<b>3</b>	<b>6</b>	<b>-</b>	<b>A</b>	<b>F</b>	<b>B</b>	<b>8</b>	<b>0</b>	<b>0</b>	<b>0</b>	<b>4</b>

**Please enter your individual encoder here**

Position 1	Position 2	Position 3	Position 4	Position 5	Position 6	Position 7	Position 8	Position 9	Position 10	Position 11	Position 12	Position 13	Position 14
<b>C</b>	<b>K</b>	<b>S</b>	<b>3</b>	<b>6</b>	<b>-</b>		<b>F</b>	<b>B</b>					

**Stranded cable, straight, 14 cores, 14 x 0,15 mm<sup>2</sup>**

Type	Part no.	Contacts	Wire length
DOL-1J14-GOM2XB7	6030948	14	0.2 m

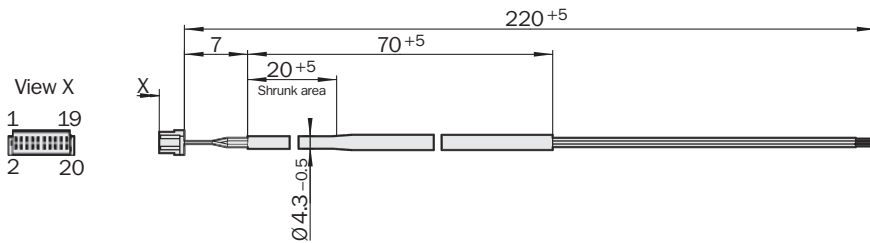

**Assembly tool**

Type	Part no.	Description
BEF-MW-SKX36	2031079	Assembly tool SKX36

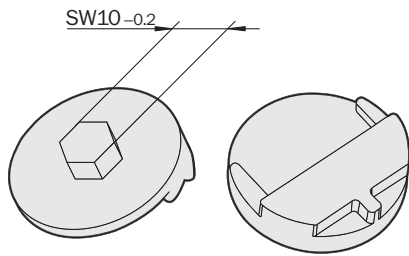

**Programming- and Adjustment Tool**

Type	Part no.	Description
PGT-06-S	1035236	Programming and Adjustment Tool
		• 110-230 V power supply unit
		• USB cable
		• Sub-D to encoder connector
		• CD with programming tool software



**Australia**

Phone +61 3 9497 4100  
1800 33 48 02 – tollfree  
E-Mail sales@sick.com.au

**Belgium/Luxembourg**

Phone +32 (0)2 466 55 66  
E-Mail info@sick.be

**Brasil**

Phone +55 11 5091-4900  
E-Mail sac@sick.com.br

**Ceská Republika**

Phone +420 2 57 91 18 50  
E-Mail sick@sick.cz

**China**

Phone +852-2763 6966  
E-Mail ghk@sick.com.hk

**Danmark**

Phone +45 45 82 64 00  
E-Mail sick@sick.dk

**Deutschland**

Phone +49 211 5301-250  
E-Mail info@sick.de

**España**

Phone +34 93 480 31 00  
E-Mail info@sick.es

**France**

Phone +33 1 64 62 35 00  
E-Mail info@sick.fr

**Great Britain**

Phone +44 (0)1727 831121  
E-Mail info@sick.co.uk

**India**

Phone +91-22-2822 7084  
E-Mail info@sick-india.com

**Italia**

Phone +39 011 79 79 65  
E-Mail info@sick.it

**Japan**

Phone +81 (0)3 3358 1341  
E-Mail support@sick.jp

**Nederlands**

Phone +31 (0)30 229 25 44  
E-Mail info@sick.nl

**Norge**

Phone +47 67 81 50 00  
E-Mail austefjord@sick.no

**Österreich**

Phone +43 (0)22 36 62 28 8-0  
E-Mail office@sick.at

**Polska**

Phone +48 22 837 40 50  
E-Mail info@sick.pl

**Republic of Korea**

Phone +82-2 786 6321/4  
E-Mail kang@sickkorea.net

**Republika Slovenija**

Phone +386 (0)1-47 69 990  
E-Mail office@sick.si

**Russia**

Phone +7 495 775 05 34  
E-Mail denis.kesaev@sickautomation.ru

**Schweiz**

Phone +41 41 619 29 39  
E-Mail contact@sick.ch

**Singapore**

Phone +65 6744 3732  
E-Mail admin@sicksgp.com.sg

**Suomi**

Phone +358-9-25 15 800  
E-Mail sick@sick.fi

**Sverige**

Phone +46 10 110 10 00  
E-Mail info@sick.se

**Taiwan**

Phone +886 2 2365-6292  
E-Mail sickgrc@ms6.hinet.net

**Türkiye**

Phone +90 216 587 74 00  
E-Mail info@sick.com.tr

**USA**

Phone +1 937-454-1956  
E-Mail sales@stegmann.com

More representatives and agencies  
in all major industrial nations at  
[www.sick.com](http://www.sick.com)

