

DL100 Pro PROFINET HighFeature

Distance sensor

SICK
Sensor Intelligence.



Described product

DL100 Pro PROFINET HighFeature

These operating instructions describe all DL100 Pro devices with a PROFINET IO interface (netload class III) with type designation DL100-2xxxx212 and firmware version V002.000.009 or higher

Manufacturer

SICK AG
Erwin-Sick-Str. 1
79183 Waldkirch
Germany

Legal information

This work is protected by copyright. Any rights derived from the copyright shall be reserved for SICK AG. Reproduction of this document or parts of this document is only permissible within the limits of the legal determination of Copyright Law. Any modification, abridgment or translation of this document is prohibited without the express written permission of SICK AG.

The trademarks stated in this document are the property of their respective owner.

© SICK AG. All rights reserved.

Original document

This document is an original document of SICK AG.



Contents

1	About this document.....	7
1.1	Information on the operating instructions.....	7
1.2	Explanation of symbols.....	7
1.3	Scope of delivery.....	8
1.4	Further information.....	8
2	Safety information.....	9
2.1	Intended use.....	9
2.2	Improper use.....	9
2.3	Cybersecurity.....	9
2.4	Limitation of liability.....	9
2.5	Modifications and conversions.....	10
2.6	Requirements for skilled persons and operating personnel.....	10
2.7	Operational safety and specific hazards.....	10
2.8	Warning signs on the device.....	11
2.9	UL conformity.....	12
3	Function and use.....	13
3.1	Configuration.....	13
3.2	Function.....	13
3.3	Type label.....	14
3.4	Display and control elements.....	14
3.4.1	LEDs.....	14
3.4.2	Display.....	15
3.4.3	Operating pushbuttons.....	16
4	Transport and storage.....	17
4.1	Transport.....	17
4.2	Transport inspection.....	17
4.3	Storage.....	17
5	Mounting.....	18
5.1	Mounting procedure.....	18
5.2	Mounting instructions.....	18
5.3	Select and mount the reflector	18
5.4	Placement of multiple distance sensors.....	21
5.5	Arranging the distance sensor to the adjacent optical data transmission system.....	23
5.5.1	Arrangement of ISD400-7xxx.....	23
5.5.2	Assignment to ISD300, ISD400-1xxx or ISD400-6xxx.....	24
5.6	Mounting the alignment bracket and distance sensor.....	25
5.7	Aligning the distance sensor and reflector with each other.....	27
5.8	Received signal level.....	28
6	Electrical installation.....	30

6.1	Safety.....	30
6.2	Wiring instructions.....	30
6.3	Connecting the device electrically.....	30
6.4	Connection diagrams.....	31
6.4.1	MF1, MF2 supply voltage connection diagram.....	31
6.4.2	Ethernet connection diagram.....	31
7	Operation.....	32
7.1	Parameter description.....	32
7.1.1	Main menu.....	32
7.1.2	SwVers menu.....	33
7.1.3	HwVers menu.....	33
7.1.4	Menu menu.....	33
7.1.5	Profin menu.....	33
7.1.6	More? menu.....	34
7.1.7	MFx On menu.....	35
7.1.8	MF1 menu.....	35
7.1.9	MF1 – Dist submenu.....	36
7.1.10	MF1 – Speed submenu.....	37
7.1.11	MF1 – Srvce submenu.....	38
7.1.12	MF1 – LsrOff submenu.....	39
7.1.13	MF1 – Preset submenu.....	40
7.1.14	MF2 menu.....	41
7.1.15	Offset menu.....	41
7.1.16	SpecFu menu.....	42
7.1.17	Performing a reset.....	43
8	Ethernet interface.....	45
8.1	Features.....	45
8.2	IP network configuration.....	45
9	SOPAS ET configuration software.....	46
9.1	Purpose.....	46
9.2	Connection of device to computer and establishment of connection..	46
9.3	Logging into the device.....	46
9.4	Firmware update.....	47
10	PROFINET IO interface.....	50
10.1	Device project planning.....	50
10.1.1	Generic station description (GSD) file.....	50
10.1.2	Reading in generic station description (GSD).....	51
10.1.3	Configuring and parameterizing nodes.....	51
10.2	GSD modules.....	52
10.2.1	Module types and module naming.....	52
10.2.2	Module overview.....	54
10.3	Module description.....	56

10.3.1	Module 1: Distance /i2w.....	56
10.3.2	Module 2: Distance/i1w.....	57
10.3.3	Module 3: Speed/i2w.....	58
10.3.4	Module 4: Distance/i2w, Speed/i2w.....	59
10.3.5	Module 5: Distance/i2w, Preset Dyn./o2w.....	60
10.3.6	Module 6: Time/i4w, Distance/i2w.....	62
10.3.7	Module 7: Time/i4w, Distance/i2w/Speed/i2w.....	63
10.3.8	Module 10: Status/i2b, Control/o2b.....	64
10.3.9	Module 13: Temp/i1b, Level/i2b, Hrs/i2b.....	66
10.3.10	Module 20: Setup MFx.....	67
10.3.11	Module 22: Setup Preset Static.....	71
10.3.12	Module 23: Setup Offset.....	71
10.3.13	Module 25: Setup Special Functions.....	72
10.3.14	Module 30: Serial No/i8b.....	74
10.3.15	Module 31: Product Code/i9w.....	74
10.3.16	Module 32: Version HW/i8b.....	74
10.3.17	Module 33: Version FPGA/i10w.....	75
10.3.18	Module 34: Version uC/i10w.....	75
10.3.19	Module 35: Version uC2/i10w.....	76
10.4	Preset – moving to initialization position.....	76
11	Maintenance.....	78
11.1	Cleaning.....	78
11.2	Maintenance plan.....	78
12	Troubleshooting.....	79
12.1	General faults, warnings, and errors.....	79
12.2	Device status (LED PWR).....	79
12.3	Warning messages.....	79
12.4	Error messages.....	80
12.5	Communication problems.....	81
12.5.1	Ethernet problems.....	81
12.5.2	PROFINET faults.....	81
12.6	Returns.....	82
12.7	Repairs.....	82
12.8	Disposal.....	82
13	Technical data.....	83
13.1	Optics.....	83
13.2	Performance data.....	83
13.3	Supply.....	84
13.4	Inputs.....	84
13.5	Outputs.....	84
13.6	Interfaces.....	84
13.7	Ambient data.....	84
13.8	Structural design.....	85

13.9	Dimensional drawing.....	86
14	Accessories.....	87
14.1	Mounting systems.....	87
14.2	Cooler housing.....	88
15	Annex.....	89
15.1	Menu structure.....	89
15.2	Declarations of conformity and certificates.....	92

1 About this document

1.1 Information on the operating instructions

These operating instructions provide important information on how to use devices from SICK AG.

Prerequisites for safe work are:

- Compliance with all safety notes and handling instructions supplied.
- Compliance with local work safety regulations and general safety regulations for device applications

The operating instructions are intended to be used by qualified personnel and electrical specialists.



NOTE

Read these operating instructions carefully to familiarize yourself with the device and its functions before commencing any work.

The operating instructions are an integral part of the product. Store the instructions in the immediate vicinity of the device so they remain accessible to staff at all times. Should the device be passed on to a third party, these operating instructions should be handed over with it.

These operating instructions do not provide information on the handling and safe operation of the machine or system in which the device is integrated. Information on this can be found in the operating instructions for the machine or system.

1.2 Explanation of symbols

Warnings and important information in this document are labeled with symbols. Signal words introduce the instructions and indicate the extent of the hazard. To avoid accidents, damage, and personal injury, always comply with the instructions and act carefully.



DANGER

... indicates a situation of imminent danger, which will lead to a fatality or serious injuries if not prevented.



WARNING

... indicates a potentially dangerous situation, which may lead to a fatality or serious injuries if not prevented.



CAUTION

... indicates a potentially dangerous situation, which may lead to minor/slight injuries if not prevented.



NOTICE

... indicates a potentially harmful situation, which may lead to material damage if not prevented.



NOTE

... highlights useful tips and recommendations as well as information for efficient and trouble-free operation.

1.3 Scope of delivery

Table 1: Scope of delivery

No. of units	Component	Note
1	Device in the version ordered	Depending on version
	Protective caps	For connections (on the device)
1	Printed safety notes, multilingual	Brief information and general safety notes

The actual scope of delivery may differ for special designs, additional orders or due to the latest technical changes.

1.4 Further information

More information can be found on the product page.

The page can be accessed via the **SICK Product ID: pid.sick.com/{P/N}/{S/N}**

{P/N} corresponds to the part number of the product, see type label.

{S/N} corresponds to the serial number of the product, see type label (if indicated).

The following information is available depending on the product:

- Data sheets
- This document in all available language versions
- CAD files and dimensional drawings
- Certificates (e.g., declaration of conformity)
- Other publications
- Software
- Accessories

2 Safety information

2.1 Intended use

The long range distance sensor is intended for non-contact measurement of distances to system components that are in linear motion. The distance measurement is performed on a reflector.

SICK AG assumes no liability for losses or damage arising from the use of the product, either directly or indirectly. This applies in particular to use of the product that does not conform to its intended purpose and is not described in this documentation.

2.2 Improper use

Any use outside of the stated areas, in particular use outside of the technical specifications and the requirements for intended use, will be deemed to be incorrect use.

- The device does not constitute a safety component in accordance with the respective applicable safety standards for machines.
- The device must not be used in explosion-hazardous areas, in corrosive environments or under extreme environmental conditions.
- Any use of accessories not specifically approved by SICK AG is at your own risk.



WARNING

Danger due to improper use!

Any improper use can result in dangerous situations.

Therefore, observe the following information:

- Product should be used only in accordance with its intended use.
- All information in the documentation must be strictly observed.
- Shut down the product immediately in case of damage.

2.3 Cybersecurity

Overview

To protect against cybersecurity threats, it is necessary to continuously monitor and maintain a comprehensive cybersecurity concept. A suitable concept consists of organizational, technical, procedural, electronic, and physical levels of defense and considers suitable measures for different types of risks. The measures implemented in this product can only support protection against cybersecurity threats if the product is used as part of such a concept.

You will find further information at www.sick.com/psirt, e.g.:

- General information on cybersecurity
- Contact option for reporting vulnerabilities
- Information on known vulnerabilities (security advisories)

2.4 Limitation of liability

Relevant standards and regulations, the latest technological developments, and our many years of knowledge and experience have all been taken into account when compiling the data and information contained in these operating instructions. The manufacturer accepts no liability for damage caused by:

- Non-adherence to the product documentation (e.g., operating instructions)
- Incorrect use
- Use of untrained staff

- Unauthorized conversions or repair
- Technical modifications
- Use of unauthorized spare parts, consumables, and accessories

2.5 Modifications and conversions



NOTICE

Modifications and conversions to the device may result in unforeseeable dangers.

Interrupting or modifying the device or SICK software will invalidate any warranty claims against SICK AG. This applies in particular to opening the housing, even as part of mounting and electrical installation.

2.6 Requirements for skilled persons and operating personnel



WARNING

Risk of injury due to insufficient training.

Improper handling of the device may result in considerable personal injury and material damage.

- All work must only ever be carried out by the stipulated persons.

The following qualifications are required for various activities:

Table 2: Activities and technical requirements

Activities	Qualification
Mounting, maintenance	<ul style="list-style-type: none"> ■ Basic practical technical training ■ Knowledge of the current safety regulations in the workplace
Electrical installation, device replacement	<ul style="list-style-type: none"> ■ Practical electrical training ■ Knowledge of current electrical safety regulations ■ Knowledge of the operation and control of the devices in their particular application
Commissioning, configuration	<ul style="list-style-type: none"> ■ Basic knowledge of the computer operating system used ■ Basic knowledge of the design and setup of the described connections and interfaces ■ Basic knowledge of data transmission
Operation of the device for the particular application	<ul style="list-style-type: none"> ■ Knowledge of the operation and control of the devices in their particular application ■ Knowledge of the software and hardware environment for the particular application

2.7 Operational safety and specific hazards

Please observe the safety notes and the warnings listed here and in other sections of this product documentation to reduce the possibility of risks to health and avoid dangerous situations.

**CAUTION****Optical radiation: Class 2 Laser Product**

The human eye is not at risk when briefly exposed to the radiation for up to 0.25 seconds. Exposure to the laser beam for longer periods of time may cause damage to the retina. The laser radiation is harmless to human skin.

- Do not look into the laser beam intentionally.
- Never point the laser beam at people's eyes.
- If it is not possible to avoid looking directly into the laser beam, e.g., during commissioning and maintenance work, suitable eye protection must be worn.
- Avoid laser beam reflections caused by reflective surfaces. Be particularly careful during mounting and alignment work.
- Do not open the housing. Opening the housing may increase the level of risk.
- Current national regulations regarding laser protection must be observed.

Caution – Use of controls or adjustments or performance of procedures other than those specified herein may result in hazardous radiation exposure.

It is not possible to entirely rule out temporary disorienting optical effects, particularly in conditions of dim lighting. Disorienting optical effects may come in the form of dazzle, flash blindness, afterimages, photosensitive epilepsy, or impairment of color vision, for example.

**WARNING****Electrical voltage!**

Electrical voltage can cause severe injury or death.

- Work on electrical systems must only be performed by qualified electricians.
- The power supply must be disconnected when attaching and detaching electrical connections.
- The product must only be connected to a voltage supply as set out in the requirements in the operating instructions.
- National and regional regulations must be complied with.
- Safety requirements relating to work on electrical systems must be complied with.

**WARNING****Risk of injury and damage caused by potential equalization currents!**

Improper grounding can lead to dangerous equipotential bonding currents, which may in turn lead to dangerous voltages on metallic surfaces, such as the housing. Electrical voltage can cause severe injury or death.

- Work on electrical systems must only be performed by qualified electricians.
- Follow the notes in the operating instructions.
- Install the grounding for the product and the system in accordance with national and regional regulations.

2.8 Warning signs on the device

A class 2 laser is installed in the device. The housing is labeled with a warning sign.

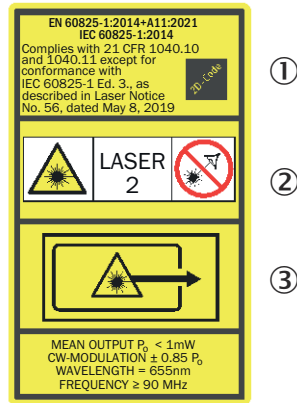

Figure 1: Warning symbol on the device: Laser class 2 (60825-1:2014+A11:2021/IEC 60825-1:2014), identical laser class for issue EN/IEC 60825-1:2007

- ① Complies with 21 CFR 1040.10 and 1040.11 except for conformance with IEC 60825-1 Ed. 3, as described in Laser Notice No. 56 dated 8 May 2019.
- ② Laser radiation – Never look into the light beam – Laser class 2 (EN 60825-1:2014+A11:2021; IEC 60825-1:2014)
- ③ Laser output aperture

2.9 UL conformity



NFPA79 applications only. Adapters including field wiring cables are available.

More information can be found on the product page:

The page can be accessed via the **SICK Product ID: pid.sick.com/{P/N}/{S/N}**

{P/N} corresponds to the part number of the product, see type label.

{S/N} corresponds to the serial number of the product, see type label (if indicated).

3 Function and use

3.1 Configuration

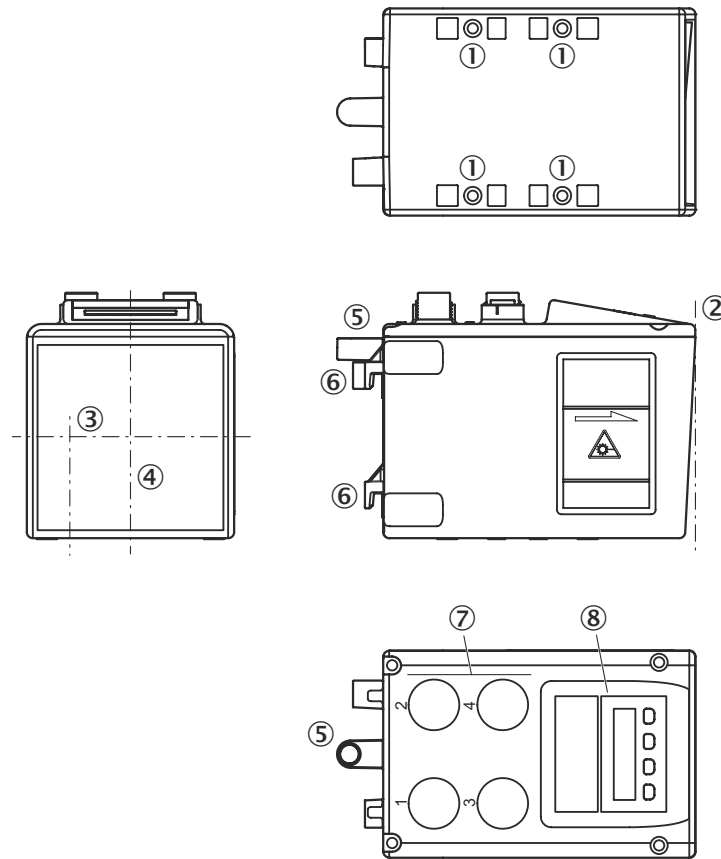

Figure 2: Distance sensor structure

- ① M5 threaded mounting hole
- ② Device zero point
- ③ Sender optical axis
- ④ Receiver optical axis
- ⑤ Hole for the star grip screw of the optional alignment bracket
- ⑥ Latch hook for alignment bracket
- ⑦ Electrical connection
- ⑧ Display and control elements

3.2 Function

The device consists of a laser, receiving optics and an integrated evaluation unit. The laser emits a light beam which is reflected back to the receiving optics by the reflector. The integrated evaluation unit determines the distance between the sensor and the reflector using phase-correlated time-of-flight measurement.

For the measurement, either the reflector or the device can move in a linear fashion along the laser beam.

The measured distance is transmitted via the data interface and can be used for control purposes or in a position control loop, for example.

3.3 Type label

The type label gives information for identification of the device.

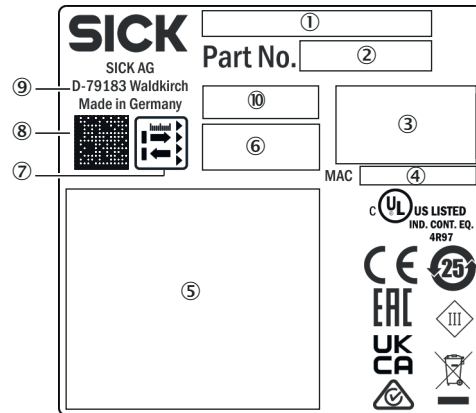

Figure 3: Type label

- ① Type code
- ② Part number
- ③ Electrical data and environmental data
- ④ MAC address
- ⑤ Pin assignment
- ⑥ Interface
- ⑦ Pictogram: Distance sensor reflector operation
- ⑧ 2D code with part number and serial number
- ⑨ Manufacturer, place of manufacture
- ⑩ Serial number, year and month of manufacture

3.4 Display and control elements

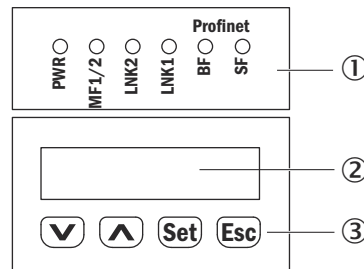

Figure 4: Display and control elements

- ① LEDs
- ② Display
- ③ Pushbuttons

3.4.1 LEDs

The status of the device and the status of all interfaces is displayed by LEDs in accordance with the following table.

Table 3: LEDs

LED	Description		
PWR	Device status display For measures, see "Troubleshooting" , page 79. <ul style="list-style-type: none"> ■ LED off: No operation ■ LED green: Interference-free operation ■ LED flashes orange: Warning ■ LED flashes red: Error 		
MF1/2	The status (output level) of the MF1 multifunctional input/output and MF2 multifunctional output		
		MF1	MF2
	LED off	LOW	LOW
	Blue LED	HIGH	LOW
	Yellow LED	LOW	HIGH
	LED, white	HIGH	HIGH
LNK1 / LNK2	Connection status (link) Ethernet port 1 and port 2 <ul style="list-style-type: none"> ■ LED flashes orange: Data exchange active ■ LED green: Connection (link) to the next participant available. ■ LED off: No physical connection to the next participant available. For measures, see "Ethernet problems", page 81. 		
BF/SF	The status of the PROFINET interface is indicated by two LEDs.		
	BF	SF	Description
	Off	Off	<ul style="list-style-type: none"> • Device is in the initialization phase (approx 1.5 s). • PROFINET connection OK
	Flashing red	Off	<ul style="list-style-type: none"> • Ethernet connection OK • PROFINET connection is being established. • Device not configured or incorrectly configured see "General faults, warnings, and errors", page 79.
	Red	Off	No Ethernet connection see "General faults, warnings, and errors" , page 79.
	Off or flashing red	Flashing red	PROFINET user flashing test active.



3.4.2 Display

The device has a display which provides a range of information. You can also call up and set parameters using the display.

Symbols for operating modes

The device has two different operating modes, "measured value display" and "menu display", which are indicated on the display by the symbols RUN and MEN.

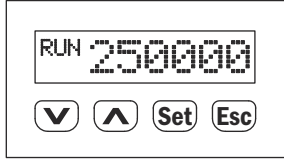
Table 4: Symbols for operating modes

Icon	Description
 <p>The image shows a digital display with the text 'RUN 250000'. Below the display are four buttons: a downward arrow, an upward arrow, a button labeled 'Set', and a button labeled 'Esc'.</p>	<p>The device is in “measured value display” operating mode when it is switched on. The RUN symbol and the current distance value are displayed. This operating mode enables you to display other process values.</p>
 <p>The image shows a digital display with the text 'MEN Menu'. Below the display are four buttons: a downward arrow, an upward arrow, a button labeled 'Set', and a button labeled 'Esc'.</p>	<p>The MEN symbol is displayed in “menu display” operating mode. In this operating mode, device parameters can be read out or set depending on the interface.</p>







NOTE

In the display, distance values always have the resolution “mm”, speed values the resolution “mm/s”. Positive numerical values do not have a sign, negative numerical values have the “-” sign. This limits the display range to 5 decimal places when numerical values are negative. In the “measured value display” operating mode, the sign and the highest decimal place are cut off and replaced by a “!” when the value -99,999 is undercut.

3.4.3 Operating pushbuttons

The device can be operated using the following 4 pushbuttons:

Table 5: Pushbuttons

Button	Description
	<ul style="list-style-type: none"> ■ Scroll through process values or (main) menu ■ Reduce value
	<ul style="list-style-type: none"> ■ Scroll through process values or (main) menu ■ Increase value.
	<ul style="list-style-type: none"> ■ Enter menu operation ■ Switches to the next lower menu level ■ Confirm selection
	<ul style="list-style-type: none"> ■ Leave value/option input of a parameter without saving. ■ Jump back to the next highest menu level or to the measured value display.

4 Transport and storage

4.1 Transport

**NOTICE****Damage due to improper transport!**

- The product must be packaged with protection against shock and damp.
- Recommendation: Use the original packaging.
- Note the symbols on the packaging.
- Do not remove packaging until immediately before you start mounting.

4.2 Transport inspection

Immediately upon receipt in Goods-in, check the delivery for completeness and for any damage that may have occurred in transit. In the case of transit damage that is visible externally, proceed as follows:

- Do not accept the delivery or only do so conditionally.
- Note the scope of damage on the transport documents or on the transport company's delivery note.
- File a complaint.

**NOTE**

Complaints regarding defects should be filed as soon as these are detected. Damage claims are only valid before the applicable complaint deadlines.

4.3 Storage

- Do not store outdoors.
- Store in a place protected from moisture and dust.
- Recommendation: Use the original packaging.
- Do not expose to any aggressive substances.
- Protect from sunlight.
- Avoid mechanical shocks.
- Storage temperature: see "Technical data", page 83.
- Relative humidity: see "Technical data", page 83.
- For storage periods of longer than 3 months, check the general condition of all components and packaging on a regular basis.

5 Mounting

5.1 Mounting procedure

1. Choose a mounting site bearing in mind the mounting instructions, see ["Mounting instructions"](#), page 18.
2. Selecting and mounting the reflector, see ["Select and mount the reflector"](#), page 18.
3. Mounting alignment bracket and distance sensor, see ["Mounting the alignment bracket and distance sensor"](#), page 25.
4. Establishing electrical connection, see ["Electrical installation"](#), page 30.
5. Aligning distance sensor and reflector to one another see ["Aligning the distance sensor and reflector with each other"](#), page 27.

5.2 Mounting instructions

- Observe the technical data.
- Protect the sensor from direct sunlight.
- To prevent condensation, avoid exposing the device to rapid changes in temperature.
- The mounting site has to be designed for the weight of the device.
- Use a sensor with optional heater at low ambient temperatures such as in cold storage.
- Use a sensor with an optional cooler housing at higher temperatures.
- Maintain a sufficient distance to other distance sensors, see ["Placement of multiple distance sensors"](#), page 21.
- Maintain a sufficient distance to the data transmission photoelectric sensors, see ["Arranging the distance sensor to the adjacent optical data transmission system"](#), page 23.

5.3 Select and mount the reflector



NOTE

Suitable reflectors and suitable reflective tape can be found on the product page . The page can be accessed via the **SICK Product ID: pid.sick.com/{P/N}/{S/N}** {P/N} corresponds to the part number of the product, see type label. {S/N} corresponds to the serial number of the product, see type label (if indicated).

Reflector size

- Select a reflector size that always allows the entire light spot to hit the reflector.
- If the reflector is mounted to a vehicle and the distance sensor is secured in place at a fixed location, you can calculate the minimum size of the reflector using the distance-based light spot size, see ["Optics"](#), page 83.
- If the distance sensor is installed onto a vehicle, a larger reflector is typically necessary for taking into account the rolling movements of the vehicle and therefore of the laser.



NOTE

The reflector must always be at least 100 mm x 100 mm in size, even if the light spot is smaller due to a shorter measuring distance.

Reflector tilt

- ▶ To avoid direct surface reflections, mount the reflector with a tilt of approx. $+1^\circ \dots +3^\circ$ in one of the 2 axes (horizontal or vertical).

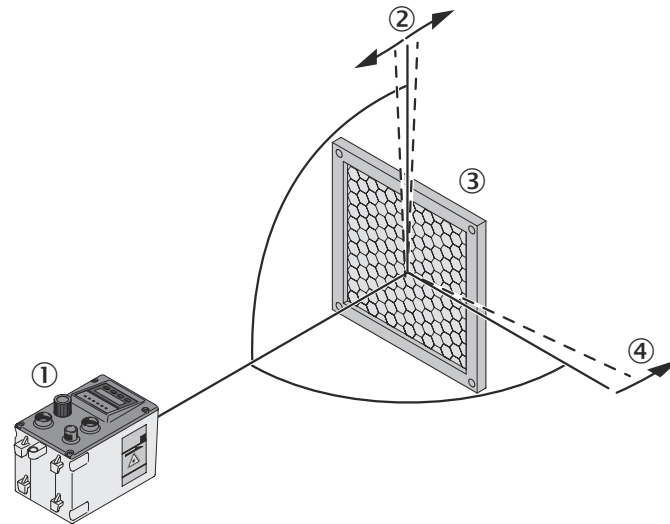

Figure 5: Reflector tilt

- ① Distance sensor
- ② Tilt of the vertical axis of the reflector approx. $+1^\circ \dots +3^\circ$
- ③ Reflector
- ④ Tilt of the horizontal axis of the reflector approx. $+1^\circ \dots +3^\circ$

- Shiny surfaces that are parallel to the laser beam axis may cause beam switching or light scatter and lead to incorrect measurements as a result. Therefore, align the reflector by giving it a $1 \dots 3^\circ$ tilt away from shiny surfaces into the free space. Shiny surfaces include, for example, storage profiles, pallets with stretch film, poles or rails.
- If the sensor is mounted in the driving axis of an automated storage and retrieval system, tilt the reflector toward the ceiling away from the rail .see figure 6, page 20.
- If the sensor is mounted in the stroke axis of an automated storage and retrieval system, tilt the reflector away from the mast system see figure 7, page 21.

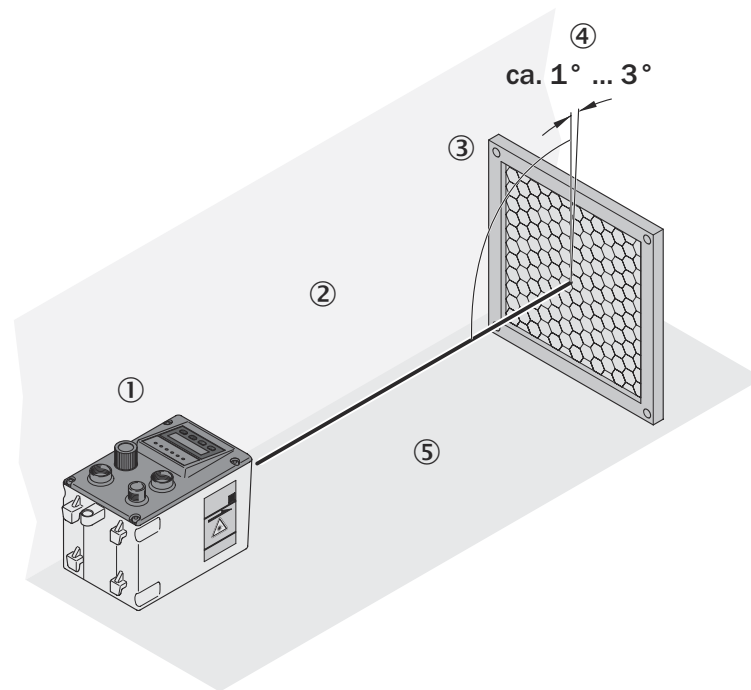

Figure 6: Reflector tilt for shiny surfaces and horizontal driving axis

- ① Device
- ② Shiny surface such as a shelving section, stretch wrap
- ③ Reflector
- ④ Tilt of approx. 1° to 3°
- ⑤ Shiny surface such as a rail

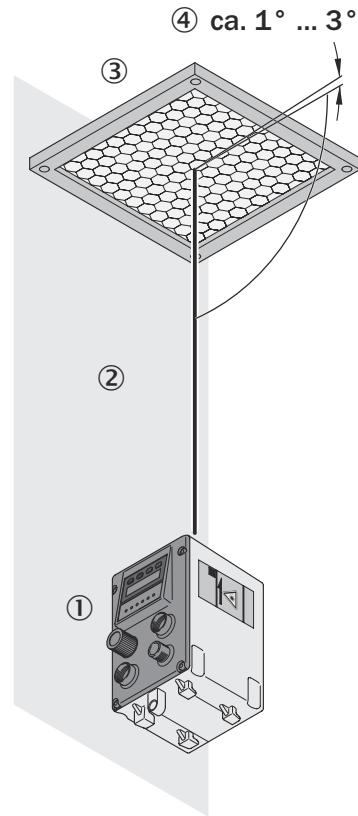

Figure 7: Reflector tilt for shiny surfaces and vertical stroke axis

- ① Sensor
- ② Shiny surface such as a mastfed automated storage and retrieval system
- ③ Reflector
- ④ Tilt of approx. 1° to 3°

5.4 Placement of multiple distance sensors

To mount several distance sensors side-by-side, you will need to maintain a minimum distance when mounting. The minimum distance a of the optical axis depends on the maximum travel distance s_{\max} . This applies to mounting with light beams in both the same and opposite directions.

Light beams in the same direction

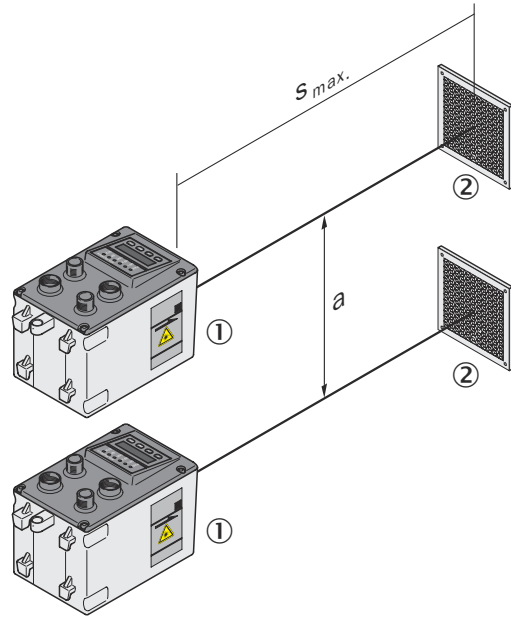

Figure 8: Placement of two distance sensors light beams in the same direction

- ① Distance sensor
- ② Reflector
- a Minimum distance
- s_{max} Maximum travel distance

Light beams in opposite directions

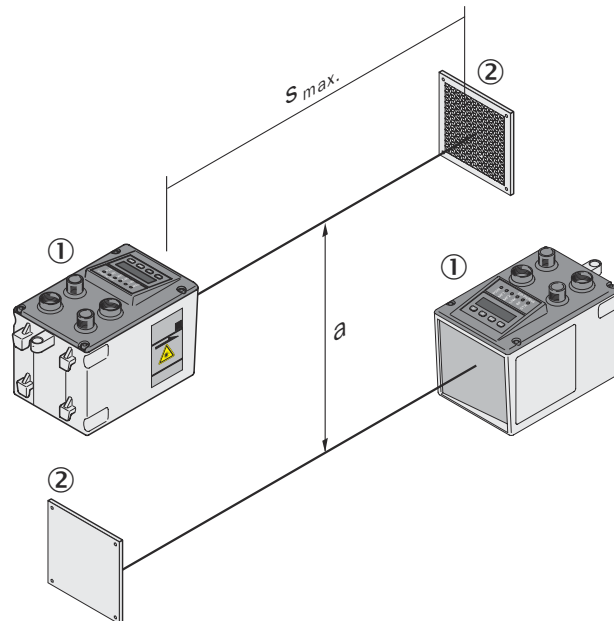

Figure 9: Placement of two distance sensors light beams in opposite directions

- ① Distance sensor
- ② Reflector
- a Minimum distance
- s_{max} Maximum travel distance

Formula

$$a \geq 0.1 \text{ m} + 0.01 \times s_{\text{max}} \text{ [m]}$$

Example

- Maximum travel distance s_{max} : 60 m
- Calculation of minimum distance: $a \geq 0.1 \text{ m} + 0.01 \times 60 \text{ m} = 0.1 \text{ m} + 0.6 \text{ m} = 0.7 \text{ m}$

Configurable modulation frequency

If the required minimum distance cannot be observed, then devices from the Dx100 series are available which are equipped with configurable modulation frequencies for avoiding mutual interference. These devices can be mounted without any minimum distance of separation from each other and are identified in the type code using the letter **B** (e.g. DL100-21AB2101). There are 3 modulation frequencies available [see "SpecFu menu", page 42.](#)

5.5 Arranging the distance sensor to the adjacent optical data transmission system

5.5.1 Arrangement of ISD400-7xxx

Dx100-2xxAxxxx

For arrangement and the travel distance from the DL100-2xxAxxxx distance sensor (or the DL100-2xxBxxxx up to serial number 1925xxxx) without integrated spectral to the ISD400-7xxx data transmission system, the following applies:

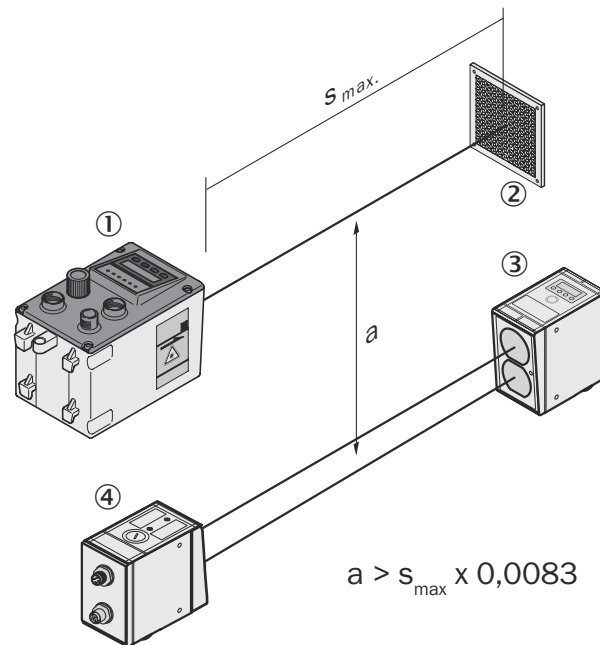

Figure 10: Arrangement of distance sensor DL100-2xxAxxxx to data transmission system ISD400-7xxx

- ① DL100-2xxAxxxx distance sensor
- ② Reflector
- ③ ISD400-7xx1, red
- ④ ISD400-7xx2, infrared
- a** Minimum distance
- s_{max}** Maximum travel distance

Formula: $a \geq 0.0083 \times s_{\text{max}}$

Example

- Maximum travel distance s_{\max} : 60 m
- Minimum distance calculation: $a \geq 0.0083 \times 60 \text{ m} = 0.5 \text{ m}$

Dx100-2xxBxxxx

No minimum distance is required for the arrangement of a distance sensor with integrated spectral filter (Dx100-2xxBxxxx from serial number 1926xxxx) to an ISD400-7xx optical data transmission system. The following arrangement is required when doing so:

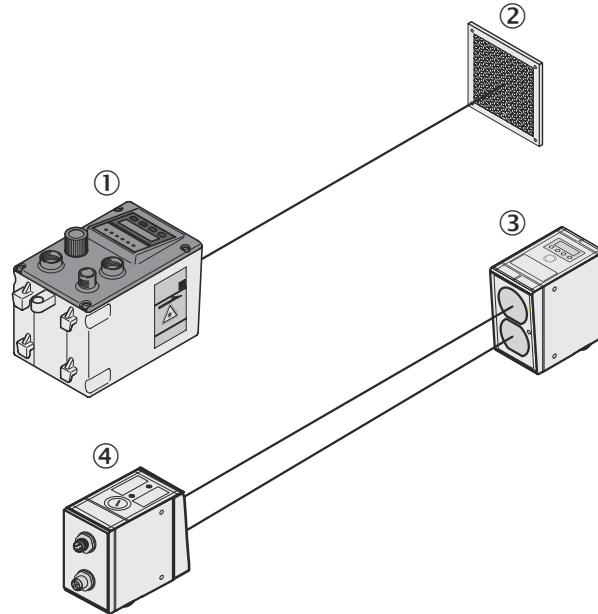

Figure 11: Arrangement of distance sensor Dx100-2xxBxxxx to data transmission system ISD400-7xx

- ① Dx100-2xxBxxxx distance sensor
- ② Reflector
- ③ ISD400-7xx2, infrared
- ④ ISD400-7xx1, red

5.5.2 Assignment to ISD300, ISD400-1xx or ISD400-6xx

A minimum distance of at least 100 mm must always be maintained when mounting a data transmission system of the ISD300, ISD400-1xx and ISD400-6xx product family. The maximum measurement distance and variant of the distance sensor does not have an impact on the minimum distance.

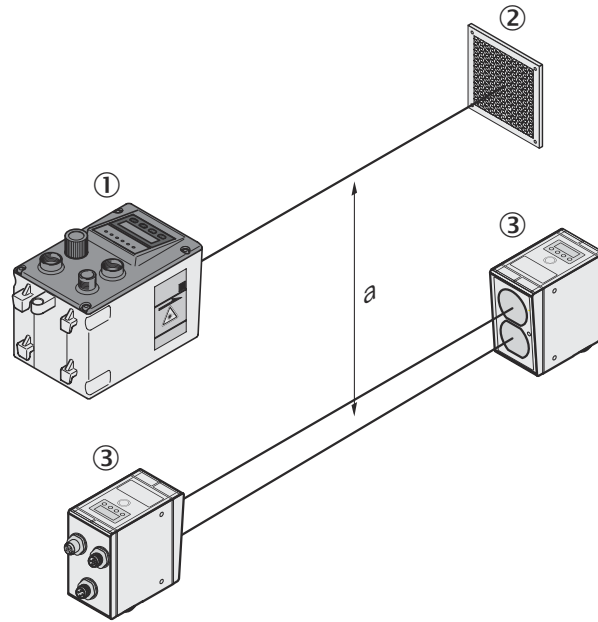

Figure 12: Arranging a distance sensor with the data transmission system

- ① Distance sensor
- ② Reflector
- ③ ISD300, ISD400-1xxx or ISD400-6xxx
- a Minimum distance, $a \geq 100$ mm

5.6 Mounting the alignment bracket and distance sensor

The distance sensor is installed using the optional alignment bracket [see "Mounting systems", page 87](#).

The alignment bracket is suitable for mounting on horizontal and vertical surfaces.

If the device is used for vertical measurements (e.g. in the stroke axis of an automated storage and retrieval system), you can mount the alignment bracket horizontally or use the optional deflector mirror.



NOTE

The operation must be accessible.

1. Mount the alignment bracket using the four slotted holes with the supplied screws.

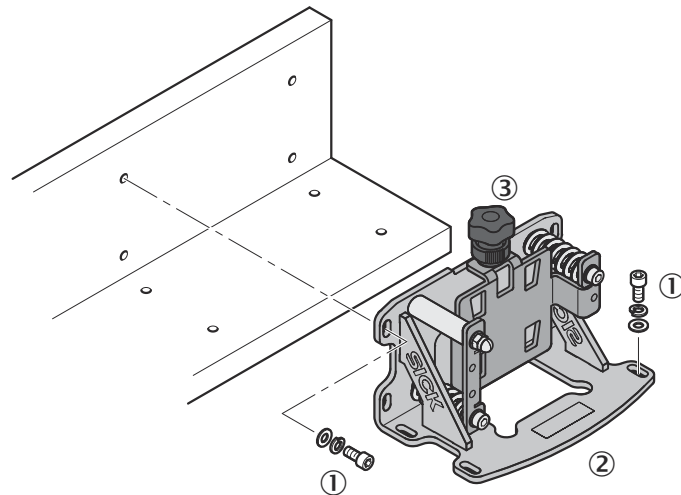

- ① Mounting screw, M5 hexagon socket screw
- ② Alignment bracket
- ③ Star grip screw

2. Unscrew the star grip screw.
3. Insert the distance sensor into the alignment bracket.

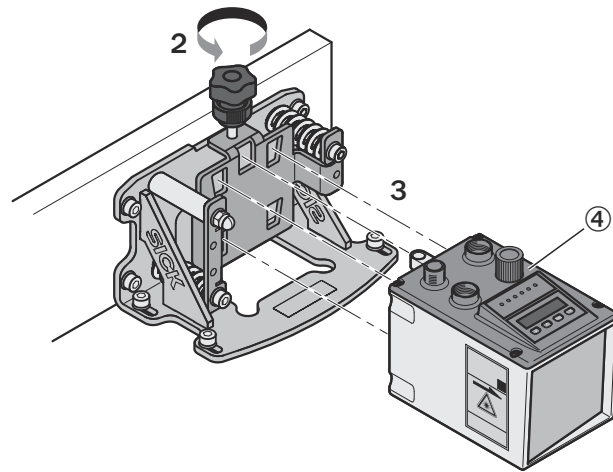

- ④ Distance sensor

4. Secure the distance sensor using the star grip screw.
5. Secure the star grip screw in place using a knurled nut.

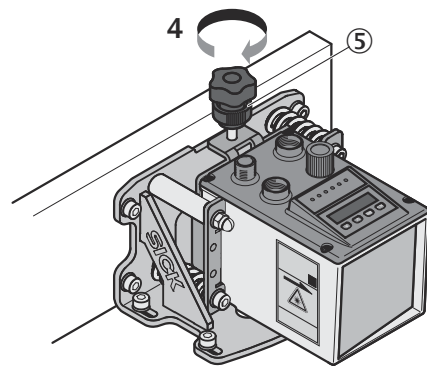

- ⑤ Knurled nut

5.7 Aligning the distance sensor and reflector with each other

Align the distance sensor using the alignment bracket according to the following figures and proceed as follows.

1. Bring the distance sensor and reflector close together.
2. Align the distance sensor so that the light spot hits the center of the reflector.
3. Increase the distance between the distance sensor and reflector. The light spot must continuously hit the center of the reflector. If necessary, adjust the alignment using the adjustment screws of the alignment bracket
4. Check the attenuation. The value for the attenuation must not exceed certain values, see "Received signal level", page 28.



NOTE

Do not change the factory setting of the adjustment screws by more than ± 3 mm. This results in a spring travel of 41.5 ± 3 mm. This results in a maximum adjustment angle of $\pm 2^\circ$ in the X- and $\pm 3.5^\circ$ in the Y-direction.

Alignment in the X-direction

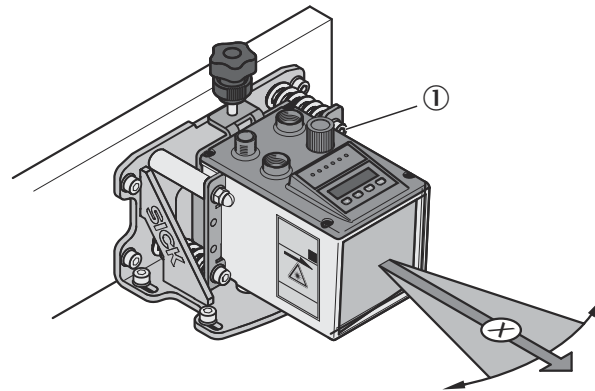

Figure 13: Align the distance sensor in the X-direction

- ① M5 hex socket adjustment screw for aligning the distance sensor in the X-direction

Alignment in the Y-direction

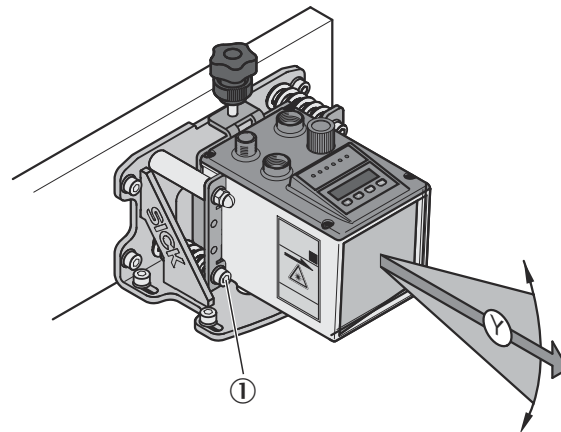

Figure 14: Align the distance sensor in the Y-direction

- ① M5 hex socket adjustment screw for aligning the distance sensor in the Y-direction

5.8 Received signal level

The highest possible received signal level is required for precise measurement. With increasing distance and/or contamination of the adjoining optical faces (sensor viewing window/reflector), the received signal level decreases. This means an increase in signal attenuation which you can read off as the dB value in the main menu.

The table below specifies the signal attenuation values in relation to the distance between the distance sensor and the reflector. The values in the “Typical signal attenuation” column represent the expected values when the measuring path and the distance sensor are in perfect working order. If the signal attenuation value exceeds the value in the “Maximum signal attenuation” column, check the condition of the measuring distance and the adjoining optical faces. The distance sensor issues a level warning if the signal attenuation value reaches the critical value of approximately -96 dB. If the signal attenuation value then continues to rise, a level and plausibility error is output, along with the measured value “0”.

Table 6: Attenuation values

Distance [m]	Typical signal attenuation [dB]	Maximum signal attenuation [dB]
10	-32	-37
20	-44	-49
35	-54	-59
60	-63	-68
100	-72	-77
130	-76	-81
200	-84	-89
220	-85	-90
300	-91	-96

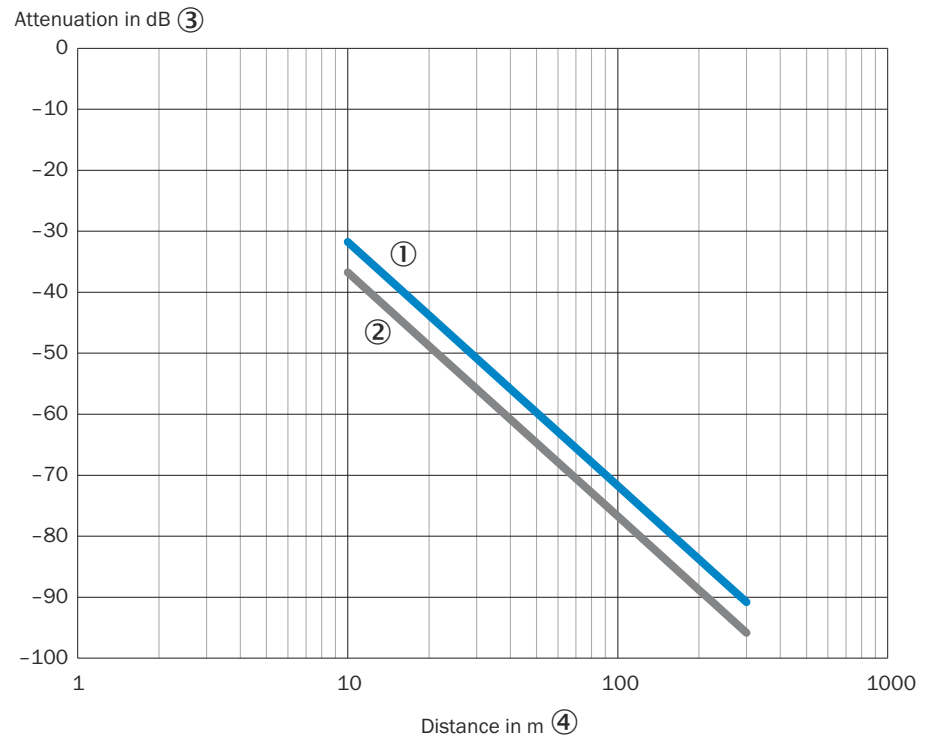

Figure 15: Signal attenuation depends on the distance between device and reflector

- ① Typical signal attenuation
- ② Maximum signal attenuation
- ③ Signal damping in dB
- ④ Distance in m

6 Electrical installation

6.1 Safety



WARNING

Personal injury due to improper supply voltage!

- Only operate the device using safety extra-low voltage and safe electrical insulation as per protection class III.
-



NOTICE

Equipment damage or unpredictable operation due to working with live parts.

Working with live parts may result in unpredictable operation.

- Only carry out wiring work when the power is off.
 - Only connect or disconnect electrical connections when the power is off.
-

6.2 Wiring instructions



NOTE

Pre-assembled cables can be found on the product page.

The page can be accessed via the **SICK Product ID: pid.sick.com/{P/N}/{S/N}**

{P/N} corresponds to the part number of the product, see type label.

{S/N} corresponds to the serial number of the product, see type label (if indicated).



NOTICE

Faults during operation and defects in the device or the system

Incorrect wiring may result in operational faults and defects.

- Follow the wiring notes precisely.
-

For data transmission, use only shielded cables with twisted-pair wires.

All electrical connections of the device are configured as M12 round connectors. The connection male connectors of the device are compatible with SpeedCon™ quick connectors and standard M12 screw connectors.

The enclosure rating stated in the technical data is achieved only with screwed plug connectors or protective caps.

In the case of open end cables, make sure that bare wire ends do not touch. Wires must be appropriately insulated from each other.

6.3 Connecting the device electrically



NOTE

The connection diagram, and information on inputs and outputs can be found on the type label on the device.

1. Ensure the voltage supply is not connected.
2. Connect the device according to the connection diagram.

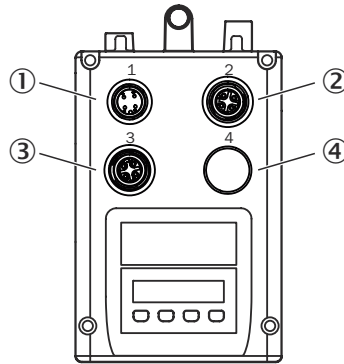

Figure 16: Position of the electrical connections

- ① Supply voltage (male connector, M12, 4-pin, A-coded)
- ② Ethernet port 1 (female connector, M12, 4-pin, D-coded)
- ③ Ethernet port 2 (female connector, M12, 4-pin, D-coded)
- ④ Not assigned (spare)

6.4 Connection diagrams

6.4.1 MF1, MF2 supply voltage connection diagram

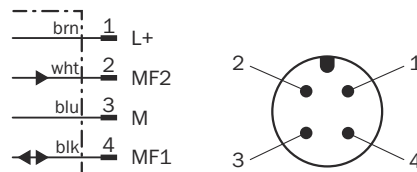

Figure 17: MF1, MF2 supply voltage connection diagram

Contact	Identifier	Wire color	Description
1	L+	Brown	Supply voltage: +18 ... +30 V DC
2	MF2	White	Multifunctional output MF2, B-type
3	M	Blue	Supply voltage: 0 V
4	MF1	Black	Multifunctional input and output MF1, B-type

6.4.2 Ethernet connection diagram

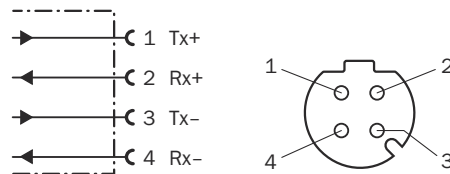

Table 7: Ethernet port connection diagram

Contact	Marking	Description
1	Tx+	Send data signal +
2	Rx+	Receive data signal +
3	Tx-	Send data signal -
4	Rx-	Receive data signal -

7 Operation



NOTICE

Device parameterization should not be carried out via the display, but exclusively via the fieldbus interface with the help of the controller-specific project planning tool, see ["Device project planning", page 50](#).



NOTICE

Pushbutton damage due to improper handling!

Improper handling of the pushbuttons can damage them. This will make operation difficult or impossible.

- Only operate the pushbuttons with your fingers or a suitable pointing device.
- Do not operate the pushbuttons using sharp or hard objects.



NOTE

For basic instructions for the display and control elements, see ["Display and control elements", page 14](#). Pressing the **Set** pushbutton for more than 2 seconds switches from **measured value display** to **menu display** operating mode.

For the overall menu structure, see ["Menu structure", page 89](#).



NOTE

Parameters set using the operating buttons are not permanently saved until the system jumps back to the measured value display. Depending on the menu level, it jumps back if the **Esc** is pushed several times or automatically if no button is pressed for longer than 90 seconds. Depending on the changed parameter, the device restarts when switching to the measured value display, which causes a brief interruption in fieldbus communication.

7.1 Parameter description

7.1.1 Main menu

The distance value is shown in the display by default. With the **Down** pushbutton, you can switch from the distance value display to the **bar graph level** display and other process values.

You can scroll through the process values in the main menu using the **Down** and **Up** pushbuttons.

Table 8: Process values

Process values	Description
Distance value	Display of distance value in mm
Bar graph level	Display of the received signal level as a bar graph
Numerical level	Display of the received signal attenuation as a numerical value see "Received signal level", page 28 .
Temperature	Display of the internal device temperature
Laser operating hours	Display of the operating hours of the laser diode
Warnings	Displays the pending warnings. If there is a warning pending, the PWR LED flashes orange. If there are no warnings pending, NoWarn is displayed, see "Warning messages", page 79 .

Process values	Description
Error	Display of the pending errors. If there is an error pending, the PWR LED flashes red. If there are no errors pending, NoErr is displayed, see "Error messages", page 80.

You get from measured value display to menu operation by pressing the **(Set)** pushbutton. You can use the **(V)** pushbutton to select between displaying the **Menu** device parameter, the **SwVers** software version and the **HwVers** hardware version in the main menu. Select the respective menu and confirm by pressing the **(Set)** pushbutton.

7.1.2 SwVers menu

The **SwVers** menu displays all information relating to the software.

Table 9: *SwVers menu*

Parameter	Description
App-uC	Displays the version of the application processor
FPGA	Displays the version of the FPGA (field programmable gate array)
Com-uC	Displays the version of the communication processor



NOTE

Since the display can only show a total of 6 characters, this information is automatically displayed as running text.

7.1.3 HwVers menu

The **HwVers** menu displays all information relating to the hardware.

Table 10: *HwVers menu*

Parameter	Description
HwVers	Display of the version number (=hardware update number). During initial delivery, this corresponds to the serial number and can change due to a hardware update during repair.

7.1.4 Menu menu

The **Menu** menu contains all device parameters.

Table 11: *Menu menu*

Options	Description
Profin	Display PROFINET interface see "Profin menu", page 33.
more?	Activation of advanced menu view see "More? menu", page 34.

7.1.5 Profin menu

You can access the PROFINET interface parameters via the **Profin** menu.

Table 12: *Profin menu*

Parameter	Description
StName	Station name display Factory setting <ul style="list-style-type: none"> • dl100hf

Parameter	Description
ResDst	<p>Select the resolution in mm for the distance output value via the digital data interface. The output value corresponds to the measured value [mm] divided by the selected resolution. The parameter does not have any influence on the measured value shown on the display.</p> <p>Prerequisite: The parameter is only displayed if the Yes option is selected for the more parameter.</p> <p>Options</p> <ul style="list-style-type: none"> • 0.1 [mm] • 0.125 [mm] • 1.0 [mm] • 10.0 [mm] • 100.0 [mm] • freRes <p>Factory setting</p> <ul style="list-style-type: none"> • 0.1 [mm]
freRes	<p>Select resolution in μm (micrometer) if the freRes value was selected in the ResDst parameter.</p> <p>Options</p> <ul style="list-style-type: none"> • 1 ... 100,000 [μm] <p>Factory setting</p> <ul style="list-style-type: none"> • 100 [μm]
ResSpd	<p>Select the resolution in mm/s for the speed output value via the digital data interface. The output value corresponds to the measured value [mm/s] divided by the selected resolution. The parameter does not have any influence on the measured value shown on the display.</p> <p>Prerequisite: The parameter is only displayed if the Yes option is selected for the more parameter.</p> <p>Options</p> <ul style="list-style-type: none"> • 0.1 [mm/s] • 1.0 [mm/s] • 10.0 [mm/s] • 100.0 [mm/s] • freRes <p>Factory setting</p> <ul style="list-style-type: none"> • 1.0 [mm/s]
freRes	<p>Select the resolution in $\mu\text{m/s}$ (micrometers per second) if the value freRes was selected in the ResSpd parameter.</p> <p>Options</p> <ul style="list-style-type: none"> • 1 ... 100,000 [$\mu\text{m/s}$] <p>Factory setting</p> <ul style="list-style-type: none"> • 1,000 [$\mu\text{m/s}$]

7.1.6 More? menu

In the **more?** menu, you can activate or deactivate the advanced menu view.

Table 13: *More?* menu

Options	Description
Yes / No	<p>Activate or deactivate advanced menu view The entire menu is displayed when activated. When deactivated, all parameters in Menu are hidden except for the PROFINET station name StName.</p> <p>Options</p> <ul style="list-style-type: none"> • Yes • No <p>Factory setting</p> <ul style="list-style-type: none"> • No

7.1.7 MFx On menu

In this menu, you can activate or deactivate multifunctional input/output MF1 and multifunctional output MF2.

Requirement for display

More? menu: **Yes** option.

Table 14: *MFx On* menu

Options	Description
Enable / Disable	<p>Activate or deactivate MF1 and MF2.</p> <p>Options</p> <ul style="list-style-type: none"> • Enable: MF1 and MF2 are activated in the hardware. • Disable: MF1 and MF2 are deactivated in the hardware and are therefore hidden in the menu. <p>Factory setting</p> <ul style="list-style-type: none"> • Enable

7.1.8 MF1 menu

You can parameterize multifunctional input/output MF1 using this menu.

Requirement for display:

- **more?** menu: **Yes** option
- Menu **MFx On:** **Enable** option

Table 15: *MF1* menu

Parameter	Description
ActSta	<p>Select the active level or signal edge of the MF1.</p> <p>Options</p> <ul style="list-style-type: none"> • ActLow: LOW level output with active output (safety criterion fulfilled) or activation of input at falling signal edge • ActHi: HIGH level output with active output (safety criterion fulfilled) or activation of input at rising signal edge <p>Factory setting</p> <ul style="list-style-type: none"> • ActLow

Parameter	Description
Functn	<p>Select MF1 function.</p> <p>Options</p> <ul style="list-style-type: none"> • Dist: MF1 is used as a distance switch output. • Speed: MF1 is used as a speed switch output. • Srvic: MF1 is used as a service output. • LsrOff: MF1 is used as an input for switching off the laser. • Preset: MF1 is used as an input for activating the static preset. <p>Factory setting</p> <ul style="list-style-type: none"> • Dist <p>The corresponding menu is displayed depending on the function selected for the Functn parameter. See the relevant table for the parameter description.</p>
Count	Counts the switching events of the MF1. You can reset the counter by switching the device off and on again.

7.1.9 MF1 – Dist submenu

In this submenu, you can configure the MF1 as a distance switch output.

Requirement for display:

- **more?** menu: **Yes** option
- Menu **MFx On:** **Enable** option
- **Functn** parameter: **Dist** option

Table 16: MF1 - Dist submenu

Parameter	Description
Limit	<p>Set switching threshold for the distance value. The digital output is activated when the current distance value exceeds the set switching threshold.</p> <p>Options</p> <ul style="list-style-type: none"> • -300,000 ... + 300,000 [mm] <p>Factory setting</p> <ul style="list-style-type: none"> • 1,990 [mm]
	<p>NOTE</p> <p>Because the display can only handle six digits, only negative values down to -99999 can be input via the operating buttons.</p> <p>Via SOPAS ET or an existing fieldbus interface, the entire value range is available as input. For values smaller than -99999, the highest decimal place is truncated in the display.</p>
	<p>The graph shows a digital output signal on the y-axis, with 'active' at the top and 'inactive' at the bottom. The x-axis is labeled 'Dist.'. A solid horizontal line is at the 'active' level until it reaches a point marked 'Limit'. At this point, the signal drops to the 'inactive' level. A dashed line shows the signal returning to the 'active' level at a point further to the right, labeled 'Hyst'. A bracket between the 'Limit' and 'Hyst' points is labeled 'Hyst', representing the hysteresis. Arrows indicate the transition from active to inactive and back to active.</p>
	<p><i>Figure 18: Representation of the Dist function</i></p> <p>Limit Distance-based switching threshold Hyst Hysteresis of switching threshold Dist Measured distance</p>
Hyst	<p>Sets hysteresis for the switching threshold.</p> <p>Options</p> <ul style="list-style-type: none"> • 1... +300,000 [mm] <p>Factory setting</p> <ul style="list-style-type: none"> • 10 [mm]

7.1.10 MF1 – Speed submenu

In this submenu, you can parameterize the MF1 as a speed switching output.

Requirement for display:

- **more?** menu: **Yes** option
- Menu **MFx On**: **Enable** option
- **Functn** parameter: **Speed** option

Table 17: MF1 – Speed submenu

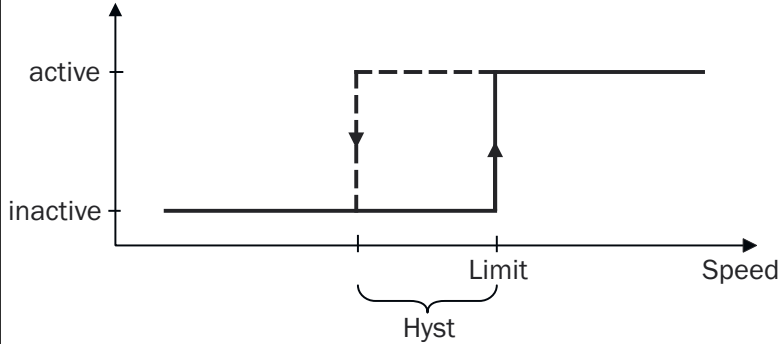
Parameter	Description
Limit	<p>Sets speed switching threshold. The digital output is activated when the current speed exceeds the set threshold. The switching hysteresis is fixed at 100 mm/s.</p> <p>Options</p> <ul style="list-style-type: none"> • 50 ... 15,000 [mm/s] <p>Factory setting</p> <ul style="list-style-type: none"> • 5,000 [mm/s]  <p><i>Figure 19: Representation of the Speed function</i></p> <p>Limit Speed-based switching threshold Hyst Hysteresis of switching threshold Speed Measured speed</p>
Sign	<p>Select the direction of travel to be monitored.</p> <p>Options</p> <ul style="list-style-type: none"> • + / -: Monitoring in both directions of movement • +: Monitoring in + direction of movement (increasing distance) • -: Monitoring in – direction of movement (decreasing distance) <p>Factory setting</p> <ul style="list-style-type: none"> • + / -

7.1.11 MF1 – Srvce submenu

In this submenu, you can parameterize the MF1 as a digital output for pending faults. The digital output is activated as soon as at least one of the selected parameters has reached the warning limit. The digital output remains active if the error limit is reached due to continued overshoot. For more information on faults, see "Troubleshooting", page 79.

For devices with integrated heating, the MF1 can also be parameterized as a digital output for the current status of the device heating, thereby monitoring the heating activity.

You can select several parameters. These are **OR** linked and assigned the MF1 as a shared output.

Requirement for display:

- **more?** menu: **Yes** option
- Menu **MFx On**: **Enable** option
- **Funcn** parameter: **Srvce** option

Table 18: MF1 – Srvce submenu

Parameter	Description
WrnLsr	<p>Activates MF1 when the aging of the laser diode means that the device is nearly due to be replaced.</p> <p>Options</p> <ul style="list-style-type: none"> • On • Off <p>Factory setting</p> <ul style="list-style-type: none"> • On
WrnLvl	<p>Activates MF1 when the signal attenuation value reaches the critical value, for example due to contamination.</p> <p>Options</p> <ul style="list-style-type: none"> • On • Off <p>Factory setting</p> <ul style="list-style-type: none"> • On
WrnTemp	<p>Activates MF1 if the interior device temperature reaches the critical value.</p> <p>Options</p> <ul style="list-style-type: none"> • On • Off <p>Factory setting</p> <ul style="list-style-type: none"> • On
WrnPib	<p>Activates MF1 if extrapolated measured values are output for implausible measured values see table 22, page 42, ErrRej. This may be caused by an internal error, hardware errors, obstruction of the light beam, optical interference or electrical interference.</p> <p>Options</p> <ul style="list-style-type: none"> • On • Off <p>Factory setting</p> <ul style="list-style-type: none"> • On
NotRdy	<p>Activates MF1 if the device is not ready for operation. Possible causes could be hardware errors, optical or electrical interference or a deactivated laser diode. This warning message is also issued during initialization.</p> <p>Options</p> <ul style="list-style-type: none"> • On • Off <p>Factory setting</p> <ul style="list-style-type: none"> • On
Heat	<p>Activates MF1 if the interior device heating is in operation. This parameter is only displayed on measuring devices with the “Heating” option.</p> <p>Options</p> <ul style="list-style-type: none"> • On • Off <p>Factory setting</p> <ul style="list-style-type: none"> • Off

7.1.12 MF1 – LsrOff submenu

You can parameterize the MF1 as a switching input to switch off the laser diode by selecting **LsrOff**. If MF1 is active, the laser diode is switched off.

Switching off the laser diodes during downtime can increase their service lives. The time span from deactivating the MF1 to renewed measured value output is max. 45 ms.

7.1.13 MF1 – Preset submenu

In this submenu, you can parameterize the MF1 as a switching input to activate the static preset. This makes it possible to automatically adjust the measured distance value to a reference value (preset) known to the system during commissioning, maintenance or device replacement.

For the static preset described here, the time for adopting the reference value in the device is determined by activating MF1. The distance value measured at this time is automatically provided with an offset and therefore adjusted to the reference value. The following applies: Offset = Preset – measured distance value.

As an alternative to MF1, presetting can be performed via the fieldbus interface see "Preset – moving to initialization position", page 76.



NOTE

When activating the preset, the output of measured values of the distance sensor will be temporarily unavailable. We recommend carrying out the preset while the machine is at a standstill or running at very low speeds. The maximum activation number is typically around 10,000 cycles. The offset value calculated when activating the preset is permanently saved in the device.

Requirement for display:

- **more?** menu: **Yes** option
- Menu **MFx On**: **Enable** option
- **Functn** parameter: **Preset** option

Table 19: MF1 – Preset submenu

Parameter	Description
sPreset	<p>Assign reference value. When activating the MF1, the reference value is adopted and the associated offset calculated.</p> <p>Options</p> <ul style="list-style-type: none"> • -300,000 ... + 300,000 [mm]. <p>Factory setting</p> <ul style="list-style-type: none"> • 0 [mm]
	<p> NOTE</p> <p>Because the display can only handle six digits, only negative values down to -99999 can be input.</p> <p>Via SOPAS ET or an existing fieldbus interface, the entire value range is available as input. For values smaller than -99999, the highest decimal place is truncated in the display.</p>

Setting the preset

1. Select the **Preset** function for multifunctional input MF1.
 2. Enter the desired initialization value for the **Preset** parameter.
 3. Drive the vehicle to the initialization position.
 4. To do so, activate multifunctional input In1 / MF1, for exemplifying using a proximity switch, a photoelectric sensor or a switch.
- ✓ The output value of the device corresponds to the set value for **Preset** at the initialization position.

7.1.14 MF2 menu

You can parameterize MF2 in this menu and its submenus.

Requirement for display:

- **more?** menu: **Yes** option
- Menu **MFx On**: **Enable** option

Table 20: MF2 menu

Parameter	Description
ActSta	Select active MF2 level. Options <ul style="list-style-type: none"> • ActLow: LOW level output with active output (safety criterion fulfilled) • ActHi: HIGH level output with active output (safety criterion fulfilled) Factory setting <ul style="list-style-type: none"> • ActLow
Functn	Select MF2 function. Options <ul style="list-style-type: none"> • Dist: MF2 is used as a distance switch output. • Speed: MF2 is used as a speed switch output. • Srvic: MF2 is used as a service output. Factory setting <ul style="list-style-type: none"> • Srvic
Count	Counts the switching events of the MF2. You can reset the counter by switching the device off and on again.

MF2 – Dist submenu

This submenu corresponds to the **Dist** submenu in the **MF1** menu see "[MF1 – Dist submenu](#)", page 36.

MF2 – Speed submenu

This submenu corresponds to the **Speed** submenu in the **MF1** menu see "[MF1 – Speed submenu](#)", page 37.

MF2 – Srvic submenu

This submenu corresponds to the **Srvic** submenu in the **MF1** menu see "[MF1 – Srvic submenu](#)", page 38.

7.1.15 Offset menu

You can set an offset in this menu.

Requirement for display:

- **more?** menu: **Yes** option

Table 21: Offset menu

Parameter	Description
Offset	<p>Specify the offset. The offset is added to the internally determined distance value. The offset is applied to all outputs and to what is shown on the distance display.</p> <p>Triggering a preset overwrites the offset. The following applies: Offset = Preset - measured distance value.</p> <p>Options</p> <ul style="list-style-type: none"> • -600,000 ... +300,000 [mm] <p>Factory setting</p> <ul style="list-style-type: none"> • 0 [mm]

7.1.16 SpecFu menu



In this menu you can set special functions.

Requirement for display:



- **more?** menu: Yes option

Table 22: SpecFu menu

Parameter	Description
AvgDst	<p>Select filter characteristic for the distance measured values.</p> <p>The distance and speed values are filtered based on a mathematical state model (Kalman filter). This model is optimized for use in continuously changing distance conditions and results in faster distance sensor response time while reducing the measured value noise at the same time.</p> <p>The set option affects both the measured value noise as well as the dynamic behavior of the distance measured value and the speed measured value derived from this. A slower filter setting reduces measured value noise but can lead to distance value overshoots if the distance changes rapidly.</p> <p>Options</p> <ul style="list-style-type: none"> • Medium • Slow • Fast <p>Factory setting</p> <ul style="list-style-type: none"> • Medium
AvgSpd	<p>Select filter depth for the speed measured values (moving average filter). The filter is downstream of the Kalman filter (see AvgDst parameter).</p> <p>Options</p> <ul style="list-style-type: none"> • Medium (8 values) • Slow (32 values) • Fast (1 value) <p>Factory setting</p> <ul style="list-style-type: none"> • Medium
MsrDir	<p>Defining measurement direction: If the measuring direction is positive +, the distance output value is equal to the internal distance value measured by the measuring module. If the measuring direction is negative -, the internal distance value is multiplied by the factor -1. The change in direction affects both the output value for the distance and the output value for the speed.</p> <p>Options</p> <ul style="list-style-type: none"> • + (positive direction) • - (negative direction) <p>Factory setting</p> <ul style="list-style-type: none"> • +

Parameter	Description
ErrRej	<p>Select time for maximum error suppression. If no measurement is possible due to an error (e.g. brief light beam interruption), measured value are extrapolated until no later than when the set error suppression time expires. During this time, a WmPlb plausibility warning is output. If no measurement is possible after expiration of the error suppression time, measured value 0, plausibility error ErrPlb and possibly other errors (e.g. level error ErrLvl) are output.</p> <p>Options</p> <ul style="list-style-type: none"> • 200 ms: Plausibility error is reported when the error is indicated for longer than 200 ms. • 50 ms: Plausibility error is reported when the error is indicated for longer than 50 ms. • Off: The plausibility error is reported when the error is indicated for longer than 5 ms. <p>Factory setting</p> <ul style="list-style-type: none"> • 200 [ms]
Heat	<p> NOTE Only for DL100-xxHxxxx variants with heating</p> <hr/> <p>In this menu, you can set the ambient temperature at which the heating turns on if undercut. The hysteresis is fixed at 3 K. Increasing the temperature set at the factory can reduce the formation of condensation in some cases.</p> <p>Options</p> <ul style="list-style-type: none"> • -10 ... +40 °C <p>Factory setting</p> <ul style="list-style-type: none"> • -10 °C
FrqSet	<p> NOTE Only for DL100-xxxBxxxx variants with frequency changeover</p> <hr/> <p>You can set laser transmission frequencies in this menu. If the minimum distance between the optical axes cannot be maintained when mounting several distance sensors, mutual interference is prevented by setting different frequencies (mode 0 ... mode 2). No minimum distance is required for this purpose see "Placement of multiple distance sensors", page 21. Mode 0 corresponds to the laser transmission frequency of the variant without switchable frequency (DL100-xxxAxxxx). Mode 3 is reserved for later use.</p> <p>Options</p> <ul style="list-style-type: none"> • Mode 0 • Mode 1 • Mode 2 • Mode 3 (reserved) <p>Factory setting</p> <ul style="list-style-type: none"> • Mode 0
Reset	Reset to factory settings see " Performing a reset ", page 43.

7.1.17 Performing a reset

1. Select the **Reset** parameter in the **SpecFu** menu see "[SpecFu menu](#)", page 42.
2. Press the  pushbutton.
- ✓ The **Sure?** confirmation prompt appears.
3. Press the  pushbutton to terminate the process.

- Press the **Set** pushbutton to reset the measuring device to factory settings.
- ✓ The **OK** reset confirmation appears.
 - 4. Press the **Esc** pushbutton several times to get back to the **measured value display** operating mode.

8 Ethernet interface

There are two equal Ethernet interfaces available on the device. They lead to an internal switch and are used for communication via PROFINET.

They can also be used for communication via SICK configuration software SOPAS ET see "SOPAS ET configuration software", page 46.

Each device has its own MAC address. The MAC address can be found on the type label see "Type label", page 14.



NOTE

You can download the SOPAS ET configuration program online at www.sick.com/SOPAS_ET.



NOTE

SOPAS ET should only be used for service purposes (e.g. diagnosis, firmware update) and not for parameterization.

8.1 Features

- Transmission rate 10 or 100 MBit, half or full duplex
- Auto-negotiation (automatic adjustment of transfer rate and duplex procedures)
- Auto-crossover (automatic adjustment in the case of Ethernet cables)
- DHCP (dynamic IP address assignment via DHCP server) or static IP address assignment

8.2 IP network configuration

During delivery or after a reset to factory settings, the following IP network configuration is set on the device:

- Dynamic IP address assignment via DHCP switched off
- Static IP address assignment switched on
- IP address: 192.168.100.236
- IP network mask: 255.255.255.0
- Default gateway: 0.0.0.0

You can change the IP network configuration via the SOPAS ET configuration software.



NOTE

If address assignment using the DHCP server is parameterized and it fails, the last selected static IP address is used for the device. The delivery configuration is used if this static IP address is invalid (IP address 0.0.0.0). This process may take up to approx. 1 minute. If the IP address is 0.0.0.0, the device cannot be found via SOPAS ET. It may be necessary to reset to factory settings and restart the device.

9 SOPAS ET configuration software

9.1 Purpose

The SOPAS ET configuration software offers uniform operation of all SICK devices and is used, among other things, for parameterization and service purposes (e.g. diagnosis, data logger, firmware update).

SOPAS ET can be downloaded from the Internet at www.sick.com/SOPAS_ET. Help with general operation of the SOPAS ET program user interface as well as for the different options can be found in the SOPAS ET online help. Parameterization of SOPAS ET is self-explanatory and is therefore not described in detail in this document.

Changes to parameters made in SOPAS ET are only saved in a non-volatile manner when the **Save** button is selected to perform a save function either via the menu bar or the respective device.



NOTE

SOPAS ET should only be used for assigning the PROFINET station name or for service purposes.

The complete device parameterization is performed via the controller-specific project planning tool (e.g., SIEMENS TIA Portal) see "[Device project planning](#)", page 50.

9.2 Connection of device to computer and establishment of connection



NOTE

The IP settings of the computer and the device must match to be able to communicate with the device via SOPAS ET. Adjustments can either be done via the IP network configuration on the device while the connection to SOPAS ET is being established, or via the network configuration in the system control of the computer (LAN connection). Administrator rights are needed to change the system control.:

1. Connect computer to the Ethernet interface of the device or a free port of a switch in-between.
- ✓ SOPAS ET automatically begins looking for connected devices after start-up.
2. Enter the found device to the project using drag & drop, double click, enter button or add icon.



NOTE

If you are requested to install a device driver in the device window during installation, the easiest thing to do is run an upload from the device and to switch to online mode by selecting the respective button in the device window.



NOTE

If SOPAS ET does not find a connected device, you can reset the IP network configuration to the factory setting 192.168.100.236 (see "[Performing a reset](#)", page 43) using the device menu then restart the device.

9.3 Logging into the device

Logging into the device is required for some functions (e.g. changing to the **Device name** or **User information** windows or a firmware update) .

Select the suggested **Maintenance technician** user level here. Depending on the set language, the name of the suggested user level changes. Regardless of which language is selected, the password is "esick".

9.4 Firmware update

The SOPAS configuration software makes it possible to update the device firmware. You can get the necessary firmware file (SICK Service Pack, *.ssp) on request from your responsible SICK sales organization (see overleaf).



NOTE

Depending on the SOPAS ET version used, the following figures can deviate slightly.

1. Copy the file onto the hard drive of the computer used for the update or onto a portable storage medium.
2. Log into the device.
3. Use the button (three dots) in the device window to start the update process.

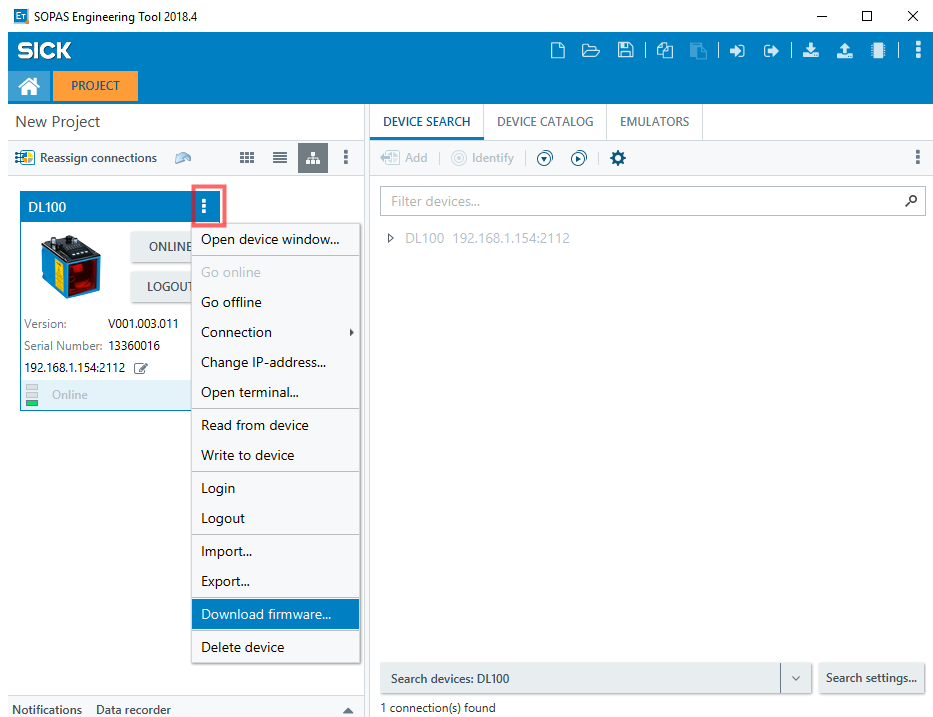

- ✓ SOPAS ET shows the firmware version of the individual components.
- 4. Select storage location of the service pack. Check whether the type code in the file name of the service pack (e.g. DL100-2xxxxx10) matches the type code on the type label of the device.
- 5. Open service pack file.
- ✓ SOPAS ET checks compatibility of the device and the service pack.
- 6. Confirm note when compatibility is given.
- ✓ Download process starts.
- ✓ Successful transmission of the new firmware is displayed.

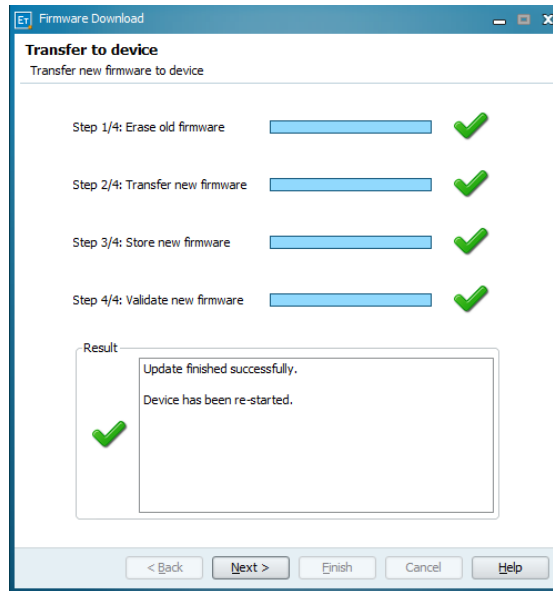

- 7. If desired: Transmit previous device parameters into the device and update the device in the current SOPAS project.

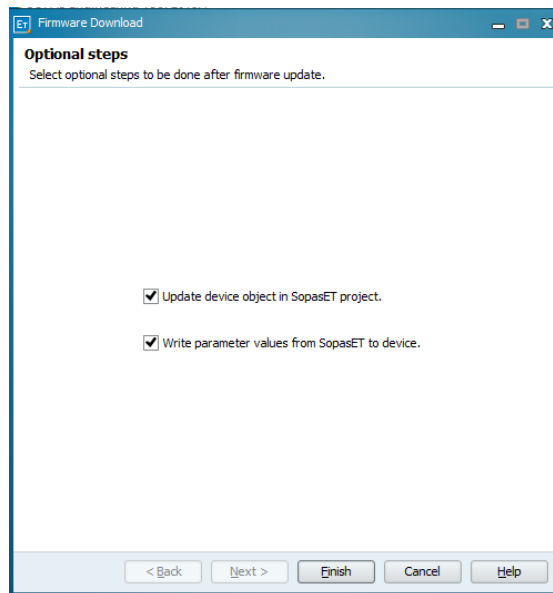

- 8. Update device driver via upload from the device.

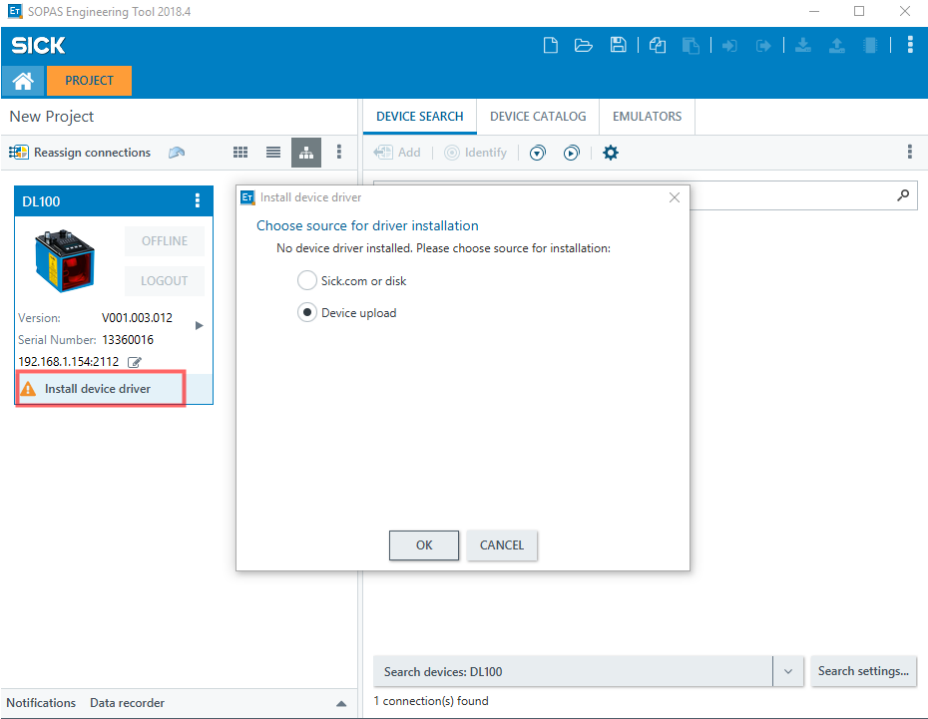

✓ Firmware update and update of the device in the SOPAS project are complete.

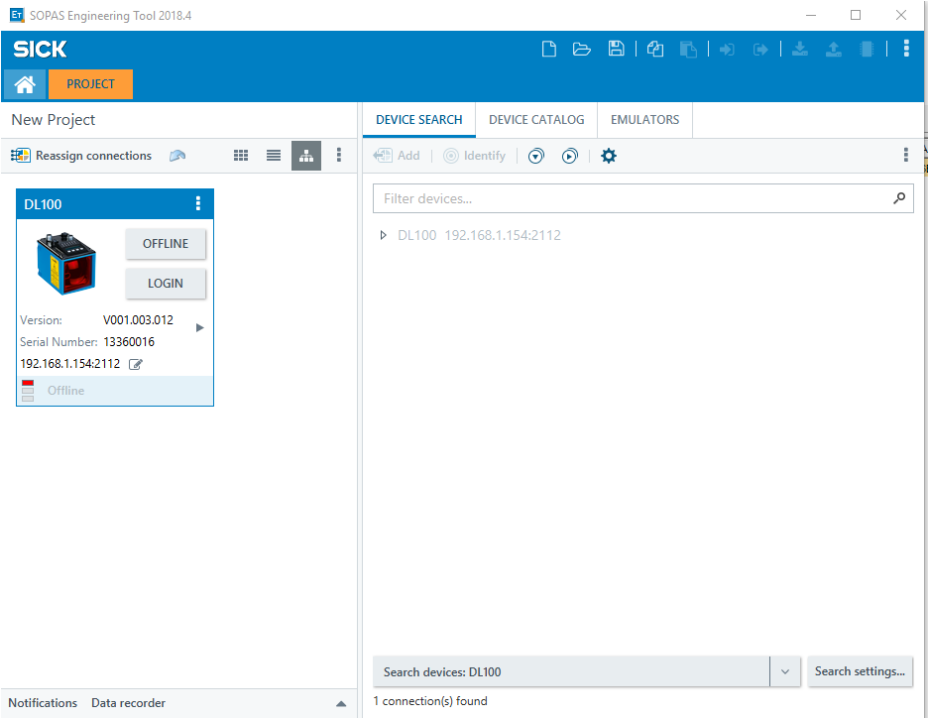

10 PROFINET IO interface

The device supports Ethernet networks with a transmission speed of 100 Mbit/s and PROFINET RT, Conformance Class B in accordance with V2.3.

It complies with PROFINET IO Security Level 1 (Netload Class III) according to specification V1.1.5.

The Auto negotiation, auto crossover and full duplex functions are also implemented. The device features an integrated dual port switch and can be used in a star or line topology. The following functions, among others, are supported by the device: Media Redundancy (MRP), Topology Detection (LLDP), Device Replacement without exchangeable medium/PG function and MIB/SNMP.

I&M functions (identification & maintenance functions)

The following I&M functions are supported:

- I&M0: Device identification
- I&M1: Users can enter system and location identification (AKZ and OKZ)
- I&M2: Installation date
- I&M3: Description of the function
- I&M4: Signature (config CRC)
- I&M5: Interface identification

The software revision of the IMO I&M function describes the version of the PROFINET interface and is not identical to the version number of the sensor firmware.

10.1 Device project planning

The device is integrated into the control project with the help of the controller-specific project planning tool (e.g., SIEMENS TIA Portal) using the generic station description file (GSD). Project planning includes configuring the device (e.g., selecting the device hardware and GSD modules for process and parameter data) as well as parameterizing the device (e.g., selecting the resolution of the distance value output, measuring direction...). After downloading the project planning details to the controller, all device parameters are stored there.

When the device is replaced, this makes it possible to transmit all device parameters from the controller to the new device (exception: PROFINET station name).

If the control and the project planning tool support the "Device replacement without exchangeable medium" PROFINET function and this has been considered during planning, the station name is automatically applied during device replacement.

Parameters set via the display or SOPAS ET are generally overwritten with the parameters defined in the project planning tool. They are also lost as soon as the device is integrated in a PROFINET network and cyclical data exchange is started.

10.1.1 Generic station description (GSD) file

A generic station description (GSD) file contains a description of the properties of a PROFINET IO device, e.g., the functions supported by the device or the digital information the controller receives from the device and the format of this information. It defines modules which can be used to flexibly adapt different control tasks [see "GSD modules", page 52](#) and [see "Module description", page 56](#).

Bitmap files are also GSD files. The status of the PROFINET IO device is visualized using these files.

The generic station description as well as the respective bitmaps are needed to plan a PROFINET IO network. Every device receives an ID number from the PROFIBUS and PROFINET user organization (PI).

Table 23: Generic station description file DL100-HF (DL100-xxxx212)

Name of the device	ID no.	GSD ¹⁾	Bitmaps
DL100-HF	5,800 (hex)	GSDML-V2.33- SICK-DL100-<date>.xml	GSDML-0101-5800-DL100_1.bmp

¹⁾ Example: For a file published on 2017-08-09, the file name is GSDML-V2.33-SICK-DL100HF-20170809.xml



NOTE

You can download the GSD file for the DL100 Pro distance sensor at www.sick.com/DX100.



NOTE

The DL100-HF GSD file only supports the DL100 Pro PROFINET High Feature (DL100-xxxx212) and DL100 Pro PROFINET/SSI (DL100-xxxx213) device variants. It is not compatible with the DL100-2xxxx112 device variants that are also available.

10.1.2 Reading in generic station description (GSD)

When configuring the device for the first time via PROFINET IO, you need to first load the generic station description file for the device into the hardware catalog of the project planning tool (e.g., SIEMENS TIA Portal).

1. Download GSD file from the website www.sick.com/DX100.
 2. Follow the instructions in the online help or in the user manual of the project planning tool in order to read in the generic station description file.
- ✓ The device is displayed in the hardware catalog in the project planning tool.

You can then use the project planning tool to integrate the device in the hardware catalog into the PROFINET IO network as well as configure and parameterize the device for your application.

10.1.3 Configuring and parameterizing nodes

Defining the station name and IP address

Every PROFINET IO field device requires a unique system-specific station name in the project plan. This must match the station name stored in the device.

The station name and IP address are defined as follows:

1. Configure a unique system-specific station name using the project planning tool.
 2. In the project planning tool, select the option to automatically assign the IP address or assign the IP address manually.
- ✓ During system startup, the PROFINET IO controller assigns the IP address based on the device name.

Selecting GSD modules

To receive measured values from the device, at least one input module from the GSD file must be added to the project from the hardware catalog of the project planning tool, e.g., the **1-Dist/i2w** module for transferring the distance value. For details on the GSD modules see "GSD modules", page 52.

If necessary, perform the parameterization in the input module, e.g., by selecting the desired resolution of the **Distance** measured value in the case of the **1-Dist/i2w** module. If required, add further GSD modules to the project plan and configure any optional parameters in the modules for the application.

Assigning a station name

The station name defined in the project plan must be assigned to the relevant device. This is done, for example, using the controller-specific project planning tool or a service tool (e.g., SIEMENS PRONETA). The nodes that can be reached via the tool are identified by means of their unique MAC address. This can be found on the type label (e.g., 00:06:77:02:00:A7) [see "Type label", page 14](#).

10.2 GSD modules

The device is a so-called modular PROFINET IO device. The composition of the sent and received data structure of a modular device is variable and consists of several individual modules.

The modules can be selected and defined by users taking into account the following conditions:

- Maximum number of modules: 16
- Maximum total length of the process data: 48 input bytes and 32 output bytes

The modules allow flexible adaptation of the device for the various control tasks. The individual modules with their respective properties are described in the GSD file.



NOTE

Device parameters that are not parameterized via the associated GSD module are set to factory settings during the transition to cyclic data exchange. This does not apply to the **Offset** parameter.

10.2.1 Module types and module naming

Module types

The device offers the following module types:

Table 24: Module types

Module type	Description
Input modules	Input modules transfer cyclic process data from the device to the PROFINET IO controller. Input modules can contain configuration data as an option.
Input and output modules	Input and output modules transfer cyclic process data both from the device to the PROFINET IO controller as well as from the PROFINET IO controller to the device. These modules can contain configuration data as an option.
Setup modules	Setup modules contain only configuration data. Setup modules cannot transfer cyclic process data to the PROFINET IO controller or receive process data from the PROFINET IO controller.

Module naming scheme

<Module number>- <Name>/<Signature>, <Name>/<Signature>, ...

Table 25: Description of the naming scheme

Component	Description
<Designation>	The module names are read from left to right, and specify the values without any gaps which are transported by the module. A value further to the left is transmitted before a value further to the right in this case. Input and output values count independently of each other.
<Signature>	<p>The signature specifies whether the value is an input or an output value, and how many words or bytes the value contains. The signature has the following structure: <direction><number><unit><direction></p> <ul style="list-style-type: none"> • i: for an input value to the controller • o: for an output value from the controller to the device <p><Unit></p> <ul style="list-style-type: none"> • b: Bytes • w: Word

Example 5-Distance/i2w, Preset Dyn/o2w

Module 5 consists of two values:

- Distance/i2w: Input value to the controller consisting of 2 words with the designation **Distance**
- Preset Dyn/o2w: Output value from controller to the device consisting of 2 words with the designation **Preset Dyn**

Example 13-Temp/i1b, Level/i2b, Hrs/i2b

Module 13 consists of three values:

- Temp/i1b: Input value to the controller consisting of 1 byte with the designation **Temp** (temperature)
- Level/i2b: Input value to the controller consisting of 2 bytes with the designation **Level**
- Hrs/i2b: Input values to the controller consisting of 2 bytes with the designation **Hrs** (operating hours counter)

Definitions

- A byte is an 8-bit value.
- A word is a 16-bit value.
- Consistency means that all values within a module are updated simultaneously.
- An input value is transferred cyclically from the device to the controller (PLC).
- An output value is transferred cyclically from the controller (PLC) to the device.
- A configuration value is transferred from the controller to the device every time the device is connected. For example, when switching on the PROFINET IO device or the controller or after the connection has been interrupted.

Relative address specification

For input and/or output modules, the relative addresses of the input or output values are specified in the module descriptions [see "Module description", page 56](#) in one of the following formats:

- <byte>, e.g., Rel. Addr. 0: byte 0
- <byte>.<bit position within the entry> e.g., Rel. Addr. 0.31: byte 0, bit 31
- <byte>.<start bit position ... end bit position within an entry>, e.g., Rel. Addr. 0.0...0.29: byte 0, bit 0...29

10.2.2 Module overview

“01_Measurements” module category,

Table 26: Module overview – “01_Measurements”,

Module number	Total size	Module type	Contents		
			Designation	Type	Size
1	2 words	Input module	Distance	Input	2 words
2	1 word	Input module	Distance	Input	1 word
3	2 words	Input module	Speed	Input	2 words
4	4 words	Input module	Distance	Input	2 words
			Speed	Input	2 words
5	2 words	Input and out-put module	Distance	Input	2 words
			Preset Dyn.	Output	Bit 0 ... 29
			Delete Preset	Output	Bit 30
			Activate Preset	Output	Bit 31
6	6 words	Input module	Time stamp	Input	4 words
			Distance	Input	2 words
7	8 words	Input module	Time stamp	Input	4 words
			Distance	Input	2 words
			Speed	Input	2 words

“02_Device Status” module category,

Table 27: Module overview – “02_Device Status”,

Module number	Total size	Module type	Contents		
			Designation	Type	Size
10	2 bytes	Input and out-put module	Status	Input	16 bit
			Control (Laser Off)	Output	16 bit
13	5 bytes	Input module	Temperature [°C]	Input	1 byte
			Signal level [dB]	Input	2 bytes
			Service hours [10 h]	Input	2 bytes

“03_Device Setup” module category,

Table 28: Module overview – “03_Device Setup”,

Module number	Total size	Module type	Contents		
			Designation	Type	Value range
20	Empty	Parameter module	MFx	Parameter	enable / disable
			Function MF1	Parameter	see "Module 20: Setup MFx", page 67
			[MF1] Active State	Parameter	high / low
			[MF1 Distance] Threshold [mm]	Parameter	-300,000 ... 300,000
			[MF1 Distance] Hysteresis [mm]	Parameter	1 ... 300,000
			[MF1 Speed] Threshold [mm/s]	Parameter	50 ... 15000
			[MF1 Speed] Mode	Parameter	[+], [-], [+/-]
			[MF1 Service] Laser Warning	Parameter	off/on
			[MF1 Service] Level Warning	Parameter	off/on
			[MF1 Service] Temp. Warning	Parameter	off/on
			[MF1 Service] Plausib. Warning	Parameter	off/on
			[MF1 Service] Not Ready	Parameter	off/on
			[MF1 Service] Heating Status	Parameter	off/on
			Function MF2	Parameter	see "Module 20: Setup MFx", page 67
			[MF2] Active State	Parameter	high / low
			[MF2 Distance] Threshold [mm]	Parameter	-300,000 ... 300,000
			[MF2 Distance] Hysteresis [mm]	Parameter	1 ... 300,000
			[MF2 Speed] Threshold [mm/s]	Parameter	50 ... 15000
			[MF2 Speed] Mode	Parameter	[+], [-], [+/-]
			[MF2 Service] Laser Warning	Parameter	off/on
			[MF2 Service] Level Warning	Parameter	off/on
			[MF2 Service] Temp. Warning	Parameter	off/on
			[MF2 Service] Plausib. Warning	Parameter	off/on
			[MF2 Service] Not Ready	Parameter	off/on
			[MF2 Service] Heating Status	Parameter	off/on

Module number	Total size	Module type	Contents		
			Designation	Type	Value range
22	Empty	Parameter module	Preset Static [mm]	Parameter	-300,000 ... 300,000
23	Empty	Parameter module	Offset [mm]	Parameter	-600000 ... 300000
25	Empty	Parameter module	Average Filter Distance	Parameter	fast, medium, slow
			Average Filter Speed	Parameter	fast, medium, slow
			Measurement Direction	Parameter	positive direction [+], negative direction [-]
			Error Rejection	Parameter	off, 50 ms, 200 ms
			Heating Threshold [degC]	Parameter	-10 ... 40
			Frequency Set	Parameter	Mode 0, mode 1 Mode 2, mode 3

“04_Device Information” module category,

Table 29: Module overview – “04_Device Information”,

Module number	Total size	Module type	Contents		
			Designation	Type	Size
30	8 bytes	Input module	Serial no	Input	8 characters
31	9 words	Input module	Product Code	Input	14 characters
			Reserved	Input	4 bytes
32	8 bytes	Input module	HW version	Input	8 characters
33	10 words	Input module	FPGA version	Input	12 characters
			Reserved	Input	8 byte
34	10 words	Input module	uC version	Input	12 characters
			Reserved	Input	8 bytes
35	10 words	Input module	Version uC2	Input	12 characters
			Reserved	Input	8 bytes

10.3 Module description

10.3.1 Module 1: Distance /i2w

Type

Input module, 2 words, consistent

Description

This module reads the current distance value.



NOTE

If there was no valid measured value due to a device fault, a missing reflector or contamination, then the value 0 is output for the distance and the corresponding bits are set in the status bytes.

Input values

Rel. Adr.	Description
0	Current distance in the selected resolution taking into account the offset and measuring direction. Type <ul style="list-style-type: none"> • Signed 32-bit number in two's complement

Module parameters

Name	Description
Distance Resolution	Select the resolution for the distance output value via the digital data interface. The output value corresponds to the measured value [mm] divided by the selected resolution. The parameter does not have any influence on the measured value shown on the display. Options <ul style="list-style-type: none"> • 0.1 mm • 0.125 mm • 1 mm • 10 mm • 100 mm • free Distance Resolution Factory setting <ul style="list-style-type: none"> • 0.1 mm
free Distance Resolution [µm]	Determines the resolution of the distance value if the free Distance Resolution value has been selected in the Distance Resolution parameter. Options <ul style="list-style-type: none"> • 1 ... 100,000 [µm] Factory setting <ul style="list-style-type: none"> • 100 [µm]

10.3.2 Module 2: Distance/i1w**Type**

Input module, 1 word, consistent

Description

This module reads the current distance value. Compared to module 1, this module consists only of a 16 bit number.

**NOTE**

If the permitted range of values of 16 bit is undercut, the following truncated values are output as error values:

- Value smaller than -32767: -32768 (Hex 0x8000) is output.
- Value is greater than 32766: 32767 (hex 0x7FFF) is output.

**NOTE**

If there was no valid measured value due to a device fault, a missing reflector or contamination, then the value 0 is output for the distance and the corresponding bits are set in the status bytes.

Input values

Rel. Adr.	Description
0	Current distance in the selected resolution taking into account the offset and measuring direction. Type <ul style="list-style-type: none"> • Signed 16-bit number in two's complement

Module parameters

Name	Description
Distance Resolution	Select the resolution for the distance output value via the digital data interface. The output value corresponds to the measured value [mm] divided by the selected resolution. The parameter does not have any influence on the measured value shown on the display. Options <ul style="list-style-type: none"> • 0.1 mm • 0.125 mm • 1 mm • 10 mm • 100 mm • free Distance Resolution Factory setting <ul style="list-style-type: none"> • 0.1 mm
free Distance Resolution [µm]	Determines the resolution of the distance value if the free Distance Resolution value has been selected in the Distance Resolution parameter. Options <ul style="list-style-type: none"> • 1 ... 100,000 [µm] Factory setting <ul style="list-style-type: none"> • 100 [µm]

10.3.3 Module 3: Speed/i2w

Type

Input module, 2 words, consistent

Description

This module reads the currently determined speed.



NOTE

If there was no valid measured value due to a device fault, a missing reflector or contamination, then the value 0 is output for the speed and the corresponding bits are set in the status bytes.

Input values

Rel. Adr.	Description
0	Current speed in the selected resolution taking into account the direction of measurement. Type <ul style="list-style-type: none"> • Signed 32-bit number in two's complement

Module parameters

Name	Description
Speed Resolution	<p>Select the resolution in mm/s for the speed output value via the digital data interface. The output value corresponds to the measured value [mm/s] divided by the selected resolution. The parameter does not have any influence on the measured value shown on the display.</p> <p>Options</p> <ul style="list-style-type: none"> • 0.1 mm/s • 1 mm/s • 10 mm/s • 100 mm/s • free Speed Resolution <p>Factory setting</p> <ul style="list-style-type: none"> • 1 mm/s
free Speed Resolution [µm/s]	<p>Determines the resolution of the speed value if the free Speed Resolution value has been selected in the Speed Resolution parameter.</p> <p>Options</p> <ul style="list-style-type: none"> • 1 ... 100,000 [µm/s] <p>Factory setting</p> <ul style="list-style-type: none"> • 1,000 [µm/s]

10.3.4 Module 4: Distance/i2w, Speed/i2w

Type

Input module, 4 words, consistent

Description

This module reads both the current distance value and the currently determined speed.

**NOTE**

If there was no valid measured value due to a device fault, a missing reflector or contamination, then the value 0 is output for the distance and the corresponding bits are set in the status bytes.

Input values

Rel. Adr.	Description
0	<p>Current distance in the selected resolution taking into account the offset and measuring direction.</p> <p>Type</p> <ul style="list-style-type: none"> • Signed 32-bit number in two's complement
4	<p>Current speed in the selected resolution taking into account the direction of measurement.</p> <p>Type</p> <ul style="list-style-type: none"> • Signed 32-bit number in two's complement

Module parameters

Name	Description
Distance Resolution	<p>Select the resolution for the distance output value via the digital data interface. The output value corresponds to the measured value [mm] divided by the selected resolution. The parameter does not have any influence on the measured value shown on the display.</p> <p>Options</p> <ul style="list-style-type: none"> • 0.1 mm • 0.125 mm • 1 mm • 10 mm • 100 mm • free Distance Resolution <p>Factory setting</p> <ul style="list-style-type: none"> • 0.1 mm
free Distance Resolution [µm]	<p>Determines the resolution of the distance value if the free Distance Resolution value has been selected in the Distance Resolution parameter.</p> <p>Options</p> <ul style="list-style-type: none"> • 1 ... 100,000 [µm] <p>Factory setting</p> <ul style="list-style-type: none"> • 100 [µm]
Speed Resolution	<p>Select the resolution in mm/s for the speed output value via the digital data interface. The output value corresponds to the measured value [mm/s] divided by the selected resolution. The parameter does not have any influence on the measured value shown on the display.</p> <p>Options</p> <ul style="list-style-type: none"> • 0.1 mm/s • 1 mm/s • 10 mm/s • 100 mm/s • free Speed Resolution <p>Factory setting</p> <ul style="list-style-type: none"> • 1 mm/s
free Speed Resolution [µm/s]	<p>Determines the resolution of the speed value if the free Speed Resolution value has been selected in the Speed Resolution parameter.</p> <p>Options</p> <ul style="list-style-type: none"> • 1 ... 100,000 [µm/s] <p>Factory setting</p> <ul style="list-style-type: none"> • 1,000 [µm/s]

10.3.5 Module 5: Distance/i2w, Preset Dyn./o2w

Type

Input and output module, 2 words, consistent

Description

This module reads the current distance value. When writing the module, the reference value (preset value) defined in it is transferred to the device. The time the reference value is applied in the device is determined by setting the most significant bit (0→1 edge change bit 31). The distance value measured at this time is automatically provided with an offset and therefore adjusted to the reference value. The following applies: Offset = Preset – measured distance value. Setting bit 30 (0→1 edge change) resets the reference value and offset to 0 mm.

As an alternative to module 5, a preset can be performed via the digital input MF1, see "Preset – moving to initialization position", page 76.

**NOTE**

A reference or offset value changed by this module is always stored in the device. Since all changed and unchanged parameters are written in the flash memory, the output of measured values is only available for a short time.

If bit 30 is set, the setting of bit 31 is ignored.

**NOTE**

If there was no valid measured value due to a device fault, a missing reflector or contamination, then the value 0 is output for the distance and the corresponding bits are set in the status bytes.

Input values

Rel. Adr.	Description
0	Current distance in the selected resolution taking into account the offset and measuring direction. Type <ul style="list-style-type: none"> Signed 32-bit number in two's complement

Output values

Rel. Adr.	Description
0.0 ... 0.29	Reference value (preset value) in the selected resolution according to module 5 Distance Resolution . Type <ul style="list-style-type: none"> Signed 32-bit number in two's complement
0.30	Resets the reference and offset value to the value 0 mm at edge change 0→1 Type <ul style="list-style-type: none"> Bit: 0 or 1
0.31	Accepts the reference value from bits 0...29 and activates the preset function at edge change 0→1. The distance value measured at this time is automatically provided with an offset and therefore adjusted to the reference value. The following applies: Offset = reference value (preset) - measured distance value. If bit 30 is set, bit 31 is ignored. Type <ul style="list-style-type: none"> Bit: 0 or 1

Module parameters

Name	Description
Distance Resolution	<p>Select the resolution for the distance output value via the digital data interface. The output value corresponds to the measured value [mm] divided by the selected resolution. The parameter does not have any influence on the measured value shown on the display.</p> <p>Options</p> <ul style="list-style-type: none"> • 0.1 mm • 0.125 mm • 1 mm • 10 mm • 100 mm • free Distance Resolution <p>Factory setting</p> <ul style="list-style-type: none"> • 0.1 mm
free Distance Resolution [µm]	<p>Determines the resolution of the distance value if the free Distance Resolution value has been selected in the Distance Resolution parameter.</p> <p>Options</p> <ul style="list-style-type: none"> • 1 ... 100,000 [µm] <p>Factory setting</p> <ul style="list-style-type: none"> • 100 [µm]

10.3.6 Module 6: Time/i4w, Distance/i2w

Type

Input module, 6 words, consistent

Description

This module reads the current distance. In addition, the module contains the time stamp for the time at which the measured value was recorded.



NOTE

If there was no valid measured value due to a device fault, a missing reflector or contamination, then the value 0 is output for the distance and the corresponding bits are set in the status bytes.

Input values

Rel. Adr.	Description
0	<p>Time stamp for the time of measured value recording.</p> <p>Type</p> <ul style="list-style-type: none"> • Time stamp, 32 bit seconds
4	<p>Time stamp for the time of measured value recording.</p> <p>Type</p> <ul style="list-style-type: none"> • Time stamp, 32 bit fractions of a second ($1/2^{32}$)
8	<p>Current distance in the selected resolution taking into account the offset and measuring direction.</p> <p>Type</p> <ul style="list-style-type: none"> • Signed 32-bit number in two's complement

Module parameters

Name	Description
Distance Resolution	<p>Select the resolution for the distance output value via the digital data interface. The output value corresponds to the measured value [mm] divided by the selected resolution. The parameter does not have any influence on the measured value shown on the display.</p> <p>Options</p> <ul style="list-style-type: none"> • 0.1 mm • 0.125 mm • 1 mm • 10 mm • 100 mm • free Distance Resolution <p>Factory setting</p> <ul style="list-style-type: none"> • 0.1 mm
free Distance Resolution [µm]	<p>Determines the resolution of the distance value if the free Distance Resolution value has been selected in the Distance Resolution parameter.</p> <p>Options</p> <ul style="list-style-type: none"> • 1 ... 100,000 [µm] <p>Factory setting</p> <ul style="list-style-type: none"> • 100 [µm]

10.3.7 Module 7: Time/i4w, Distance/i2w/Speed/i2w

Type

Input module, 8 words, consistent

Description

This module reads both the current distance value and the currently determined speed. In addition, the module contains the time stamp for the time at which the measured value was recorded.



NOTE

If there was no valid measured value due to a device fault, a missing reflector or contamination, then the value 0 is output for the distance and the corresponding bits are set in the status bytes.

Input values

Rel. Adr.	Description
0	<p>Time stamp for the time of measured value recording.</p> <p>Type</p> <ul style="list-style-type: none"> • Time stamp, 32 bit seconds
4	<p>Time stamp for the time of measured value recording.</p> <p>Type</p> <ul style="list-style-type: none"> • Time stamp, 32 bit fractions of a second ($1/2^{32}$)
8	<p>Current distance in the selected resolution taking into account the offset and measuring direction.</p> <p>Type</p> <ul style="list-style-type: none"> • Signed 32-bit number in two's complement

Rel. Adr.	Description
12	<p>Current speed in the selected resolution taking into account the direction of measurement.</p> <p>Type</p> <ul style="list-style-type: none"> Signed 32-bit number in two's complement

Module parameters

Name	Description
Distance Resolution	<p>Select the resolution for the distance output value via the digital data interface. The output value corresponds to the measured value [mm] divided by the selected resolution. The parameter does not have any influence on the measured value shown on the display.</p> <p>Options</p> <ul style="list-style-type: none"> 0.1 mm 0.125 mm 1 mm 10 mm 100 mm free Distance Resolution <p>Factory setting</p> <ul style="list-style-type: none"> 0.1 mm
free Distance Resolution [µm]	<p>Determines the resolution of the distance value if the free Distance Resolution value has been selected in the Distance Resolution parameter.</p> <p>Options</p> <ul style="list-style-type: none"> 1 ... 100,000 [µm] <p>Factory setting</p> <ul style="list-style-type: none"> 100 [µm]
Speed Resolution	<p>Select the resolution in mm/s for the speed output value via the digital data interface. The output value corresponds to the measured value [mm/s] divided by the selected resolution. The parameter does not have any influence on the measured value shown on the display.</p> <p>Options</p> <ul style="list-style-type: none"> 0.1 mm/s 1 mm/s 10 mm/s 100 mm/s free Speed Resolution <p>Factory setting</p> <ul style="list-style-type: none"> 1 mm/s
free Speed Resolution [µm/s]	<p>Determines the resolution of the speed value if the free Speed Resolution value has been selected in the Speed Resolution parameter.</p> <p>Options</p> <ul style="list-style-type: none"> 1 ... 100,000 [µm/s] <p>Factory setting</p> <ul style="list-style-type: none"> 1,000 [µm/s]

10.3.8 Module 10: Status/i2b, Control/o2b

Type

Input and output module, 2 bytes

Description

This module reads the device status bytes and writes the control bytes into the device. An active bit (bit = 1) in the status bytes means that the event listed in the associated description is present. For possible causes and how to troubleshoot warnings or errors see ["General faults, warnings, and errors", page 79](#).

Input values

Rel. Adr.	Description
0.0	<p>Bit = 1: Plausibility warning Measured values are faulty. Extrapolated measured values are output instead see table 22, page 42, ErrRej. This may be caused by an internal error, hardware errors, obstruction of the light beam, optical interference or electrical interference. The likelihood of an error occurring is high.</p> <p>Type</p> <ul style="list-style-type: none"> • 1 bit
0.1	<p>Bit = 1: Temperature warning Internal temperature of the device has reached the critical value. The likelihood of an error occurring is high.</p> <p>Type</p> <ul style="list-style-type: none"> • 1 bit
0.2	<p>Bit = 1: Signal level warning The signal attenuation has reached the critical value, e.g., due to contamination. The likelihood of an error occurring is high.</p> <p>Type</p> <ul style="list-style-type: none"> • 1 bit
0.3	<p>Bit = 1: Laser warning The device must be replaced soon due to aging of the laser diode. The likelihood of an error occurring is high.</p> <p>Type</p> <ul style="list-style-type: none"> • 1 bit
0.4	<p>Bit = 1: Plausibility error No valid measured value can be calculated.</p> <p>Type</p> <ul style="list-style-type: none"> • 1 bit
0.5	<p>Bit = 1: Temperature error The device is operating outside the specified temperature range.</p> <p>Type</p> <ul style="list-style-type: none"> • 1 bit
0.6	<p>Bit = 1: Signal level error The signal attenuation is too high.</p> <p>Type</p> <ul style="list-style-type: none"> • 1 bit
0.7	<p>Bit = 1: Laser error Laser error – the laser diode may have reached the end of its service life see "Module 13: Temp/i1b, Level/i2b, Hrs/i2b", page 66.</p> <p>Type</p> <ul style="list-style-type: none"> • 1 bit
1.0	<p>Bit = 1: Laser switched off</p> <p>Type</p> <ul style="list-style-type: none"> • 1 bit

Rel. Adr.	Description
1.1	Bit = 1: Device-internal heating in operation Type • 1 bit
1.2	Bit = 1: Either a input level is active at MF1 of the output is active. Type • 1 bit
1.3	Bit = 1: MF2 output is active. Type • 1 bit
1.4 ... 1.6	Reserved Type • 1 bit
1.7	<ul style="list-style-type: none"> • Bit = 0: Device ready for operation • Bit = 1: Device not ready for operation. Possible causes could be hardware errors, temperature errors, optical or electrical interference or a deactivated laser diode. Type • 1 bit

Output values

Rel. Adr.	Description
0.0 ... 0.7	Reserved Type • 1 bit
1.0	<ul style="list-style-type: none"> • Bit = 1: Switch off laser • Bit = 0: Switch on laser Type • 1 bit
1.1 ... 1.7	Reserved Type • 1 bit

10.3.9 Module 13: Temp/i1b, Level/i2b, Hrs/i2b

Type

Input module, 5 bytes, consistent

Description

The diagnostic data of the device can be read using this module.

Input values

Rel. Adr.	Description
0	Device temperature [°C] Type • Signed 8-bit number in two´s complement

Rel. Adr.	Description
1	Signal attenuation [dB] see "Received signal level", page 28. Type <ul style="list-style-type: none"> Signed 16-bit number in two's complement
3	Operating hours in units of 10 hours. Type <ul style="list-style-type: none"> Signed 16-bit number in two's complement

10.3.10 Module 20: Setup MFx

Type

Configuration module, no input and output data

Description

This module defines the behavior of the switchable MF1 input and output.

Table 30: Module parameters for Setup MFx

Name	Description
MFx	Activate or deactivate MF1 and MF2. Options <ul style="list-style-type: none"> enable Disable Factory setting <ul style="list-style-type: none"> enable

Table 31: MF1 module parameter

Name	Description
Function MF1	Select function for MF1 input and output. Options <ul style="list-style-type: none"> [Output] Distance Threshold: Output is switched when the distance has been overwritten from the module parameter [MF1 Distance] threshold. [Output] Speed Threshold: Output switches when the speed limit from the [MF1 Speed] Threshold module parameter has been exceeded. The direction is set in the [MF1 Speed] Mode module parameter. [Output] Service: The output switches if at least one of the service bits selected under [MF1 Service] Laser Warning...[MF1 Service] Heating has been set. [Input] Laser Off: Measurement laser is deactivated via the input. [Input] Preset Static: "Preset Static" function activated via the input. Factory setting <ul style="list-style-type: none"> [Output] Distance Threshold
[MF1] Active State	Select active level or signal edge of MF1 Options <ul style="list-style-type: none"> low High Factory setting <ul style="list-style-type: none"> low
[MF1 Distance] Threshold [mm]	Enter the distance threshold value. Options <ul style="list-style-type: none"> -300,000 ... 300,000 [mm] Factory setting <ul style="list-style-type: none"> 1,990 [mm]

Name	Description
[MF1 Distance] Hysteresis [mm]	Enter the distance threshold hysteresis see "MF1 – Dist submenu", page 36. Options <ul style="list-style-type: none"> • 1 ... 300,000 [mm] Factory setting <ul style="list-style-type: none"> • 10 [mm]
[MF1 Speed] Threshold [mm/s]	Enter speed threshold. The switching hysteresis is fixed at 100 mm/s. Options <ul style="list-style-type: none"> • 0 ... 15,000 [mm/s] Factory setting <ul style="list-style-type: none"> • 5,000 [mm/s]
[MF1 Speed] Mode	Select direction for detecting the speed overrun. Options <ul style="list-style-type: none"> • negative direction [-] • positive direction [+] • both directions [+/-] Factory setting <ul style="list-style-type: none"> • both directions [+/-]
[MF1 Service] Laser Warning	The output switches when the aging of the laser diode means that the device is nearly due to be replaced. Options <ul style="list-style-type: none"> • off • on Factory setting <ul style="list-style-type: none"> • on
[MF1 Service] Level Warning	The output switches when the signal attenuation value reaches the critical value, for example due to contamination. Options <ul style="list-style-type: none"> • off • on Factory setting <ul style="list-style-type: none"> • on
[MF1 Service] Temp. Warning	The output switches when the interior device temperature reaches the critical value. Options <ul style="list-style-type: none"> • off • on Factory setting <ul style="list-style-type: none"> • on
[MF1 Service] Plausib. Warning	The output switches if extrapolated measured values are to be output for implausible measured values see table 22, page 42, ErrRej. This may be caused by an internal error, hardware errors, obstruction of the light beam, optical interference or electrical interference. Options <ul style="list-style-type: none"> • off • on Factory setting <ul style="list-style-type: none"> • on

Name	Description
[MF1 Service] Not Ready	<p>The output switches when the device is not ready for operation. Possible causes could be hardware errors, optical or electrical interference or a deactivated laser diode. This warning message is also issued during initialization.</p> <p>Options</p> <ul style="list-style-type: none"> • off • on <p>Factory setting</p> <ul style="list-style-type: none"> • on
[MF1 Service] Heating Status	<p>The output switches if the internal device heater is in operation.</p> <p>Options</p> <ul style="list-style-type: none"> • off • on <p>Factory setting</p> <ul style="list-style-type: none"> • on

Table 32: MF2 module parameters

Name	Description
Function MF2	<p>Select function for MF2 output.</p> <p>Options</p> <ul style="list-style-type: none"> • [Output] Distance Threshold: Output is switched when the distance has been overwritten from the module parameter [MF2 Distance] threshold. • [Output] Speed Threshold: Output switches when the speed limit from the [MF2 Speed] Threshold module parameter has been exceeded. The direction is set in the [MF2 Speed] Mode module parameter. • [Output] Service: The output switches if at least one of the service bits selected under [MF2 Service] Laser Warning...[MF2 Service] Heating has been set. <p>Factory setting</p> <ul style="list-style-type: none"> • [Output] Distance Threshold
[MF2] Active State	<p>Select the active level or signal edge of the MF2.</p> <p>Options</p> <ul style="list-style-type: none"> • low • High <p>Factory setting</p> <ul style="list-style-type: none"> • low
[MF2 Distance] Threshold [mm]	<p>Enter the distance threshold value.</p> <p>Options</p> <ul style="list-style-type: none"> • -300,000 ... 300,000 [mm] <p>Factory setting</p> <ul style="list-style-type: none"> • 1,990 [mm]
[MF2 Distance] Hysteresis [mm]	<p>Enter the distance threshold hysteresis.</p> <p>Options</p> <ul style="list-style-type: none"> • 1 ... 300,000 [mm] <p>Factory setting</p> <ul style="list-style-type: none"> • 10 [mm]

Name	Description
[MF2 Speed] Threshold [mm/s]	Enter speed threshold. The switching hysteresis is fixed at 100 mm/s. Options <ul style="list-style-type: none"> • 0 ... 15,000 [mm/s] Factory setting <ul style="list-style-type: none"> • 5,000 [mm/s]
[MF2 Speed] Mode	Select direction for detecting the speed overrun. Options <ul style="list-style-type: none"> • negative direction [-] • positive direction [+] • both directions [+/-] Factory setting <ul style="list-style-type: none"> • both directions [+/-]
[MF2 Service] Laser Warning	The output switches when the aging of the laser diode means that the device is nearly due to be replaced. Options <ul style="list-style-type: none"> • off • on Factory setting <ul style="list-style-type: none"> • on
[MF2 Service] Level Warning	The output switches when the signal attenuation value reaches the critical value, for example due to contamination. Options <ul style="list-style-type: none"> • off • on Factory setting <ul style="list-style-type: none"> • on
[MF2 Service] Temp. Warning	The output switches when the interior device temperature reaches the critical value. Options <ul style="list-style-type: none"> • off • on Factory setting <ul style="list-style-type: none"> • on
[MF2 Service] Plausib. Warning	The output switches if extrapolated measured values are to be output for implausible measured values see table 22, page 42, ErrRej . This may be caused by an internal error, hardware errors, obstruction of the light beam, optical interference or electrical interference. Options <ul style="list-style-type: none"> • off • on Factory setting <ul style="list-style-type: none"> • on

Name	Description
[MF2 Service] Not Ready	The output switches when the device is not ready for operation. Possible causes could be hardware errors, optical or electrical interference or a deactivated laser diode. This warning message is also issued during initialization. Options <ul style="list-style-type: none"> • off • on Factory setting <ul style="list-style-type: none"> • on
[MF2 Service] Heating Status	The output switches if the internal device heater is in operation. Options <ul style="list-style-type: none"> • off • on Factory setting <ul style="list-style-type: none"> • on

10.3.11 Module 22: Setup Preset Static

Type

Configuration module, no input and output data

Description

This module is used to set the reference value for the static preset via digital input MF1 see "[MF1 – Preset submenu](#)", page 40.



NOTE

If module 5 **Distance/i2w, Preset Dyn./o2w** is also loaded, the static preset value is overwritten by the dynamic preset value from the input data of module 5.

Module parameters

Name	Description
Distance Preset Static [mm]	Define the distance preset value. Options <ul style="list-style-type: none"> • -300,000 ... 300,000 [mm] Factory setting <ul style="list-style-type: none"> • 0 [mm]

10.3.12 Module 23: Setup Offset

Type

Configuration module, no input and output data

Description

This module is used to set the offset.



NOTE

If a preset is triggered via module 5 **Distance/i2w, Preset Dyn./o2w** or digital input MF1, the offset value specified via module 23 is overwritten by the offset value calculated during the preset.

Module parameters

Name	Description
Distance Offset [mm]	<p>Specify the offset. The offset is added to the internally determined distance value. The offset is applied to all outputs and to what is shown on the distance display.</p> <p>Triggering a preset overwrites the offset. The following applies: Offset = Preset - measured distance value.</p> <p>Options</p> <ul style="list-style-type: none"> • -600,000 ... +300,000 [mm] <p>Factory setting</p> <ul style="list-style-type: none"> • 0 [mm]

10.3.13 Module 25: Setup Special Functions

Type



Configuration module, no input and output data

Description

This module can be used to set the filter characteristic for the measured distance values, the filter depth for the measured speed values, the measurement direction, the time for maximum error suppression, the temperature threshold for switching on the heater, and the laser transmission frequency.

Module parameters

Name	Description
Average Filter Distance	<p>Select filter characteristic for the distance measured values.</p> <p>The distance and speed values are filtered based on a mathematical state model (Kalman filter). This model is optimized for use in continuously changing distance conditions and results in faster distance sensor response time while reducing the measured value noise at the same time.</p> <p>The set option affects both the measured value noise as well as the dynamic behavior of the distance measured value and the speed measured value derived from this. A slower filter setting reduces measured value noise but can lead to distance value overshoots if the distance changes rapidly.</p> <p>Options</p> <ul style="list-style-type: none"> • Medium • Slow • Fast <p>Factory setting</p> <ul style="list-style-type: none"> • Medium
Average Filter Speed	<p>Select filter depth for the speed measured values (moving average filter). The filter is downstream of the Kalman filter (see <code>AvgDst</code> parameter).</p> <p>Options</p> <ul style="list-style-type: none"> • Medium (8 values) • Slow (32 values) • Fast (1 value) <p>Factory setting</p> <ul style="list-style-type: none"> • Medium

Name	Description
Measuring Direction	<p>Select measuring direction for the distance.</p> <p>Options</p> <ul style="list-style-type: none"> Negative direction [-] Positive direction [+] <p>Factory setting</p> <ul style="list-style-type: none"> Positive direction [+]
Error Rejection	<p>Select time for maximum error suppression. If no measurement is possible due to an error (e.g. brief light beam interruption), measured value are extrapolated until no later than when the set error suppression time expires. During this time, a WrmPIb plausibility warning is output. If no measurement is possible after expiration of the error suppression time, measured value 0, plausibility error ErrPIb and possibly other errors (e.g. level error ErrLvl) are output.</p> <p>Options</p> <ul style="list-style-type: none"> 200 ms: Plausibility error is reported when the error is indicated for longer than 200 ms. 50 ms: Plausibility error is reported when the error is indicated for longer than 50 ms. Off: The plausibility error is reported when the error is indicated for longer than 5 ms. <p>Factory setting</p> <ul style="list-style-type: none"> 200 [ms]
Heating threshold [degC]	<p> NOTE Only for DL100-xxHxxxx variants with heating</p> <hr/> <p>Select the ambient temperature below which the heater should switch on. The hysteresis is fixed at 3 K. Increasing the temperature set at the factory can reduce the formation of condensation in some cases.</p> <p>Options</p> <ul style="list-style-type: none"> -10 ... +40 °C <p>Factory setting</p> <ul style="list-style-type: none"> -10 °C
Frequency Mode	<p> NOTE Only for DL100-xxxBxxxx variants with frequency changeover</p> <hr/> <p>Set the laser transmission frequencies. If the minimum distance between the optical axes cannot be maintained when mounting several distance sensors, mutual interference is prevented by setting different frequencies (mode 0 ... mode 2). No minimum distance is required for this purpose see "Placement of multiple distance sensors", page 21.</p> <p>Mode 0 corresponds to the laser transmission frequency of the variant without switchable frequency (DL100-xxxAxxxx). Mode 3 is reserved for later use.</p> <p>Options</p> <ul style="list-style-type: none"> Mode 0 Mode 1 Mode 2 Mode 3 (reserved) <p>Factory setting</p> <ul style="list-style-type: none"> Mode 0

10.3.14 Module 30: Serial No/i8b

Type

Input module, 8 bytes

Description

The serial number of the device can be queried using this module.

Input values

Rel. Adr.	Description
0	<p>Displays the serial number as a string in the format YYWWnnnn.</p> <ul style="list-style-type: none"> • YY: Year of manufacture • WW: Week of manufacture • nnnn: Sequential number <p>Type</p> <ul style="list-style-type: none"> • 8 ASCII characters

10.3.15 Module 31: Product Code/i9w

Type

Input module, 18 bytes

Description

The product code of the device can be queried using this module.

Input values

Rel. Adr.	Description
0	<p>Displays the product code as a string in the format DL100-XXXXXXXX. Unused characters at the end of the string are filled with 0 bytes (0x00).</p> <p>Type</p> <ul style="list-style-type: none"> • 18 ASCII characters

10.3.16 Module 32: Version HW/i8b

Type

Input module, 8 bytes

Description

This module can be used to query the version number (=hardware update number). During initial delivery, this corresponds to the serial number and can change due to a hardware update during repair.



NOTE

If the value is not present in the device, a zero byte (0x00) is transmitted for each character.

Input values

Rel. Adr.	Description
0	<p>Displays the version number of the device hardware as a string in the format YYWWnnnn.</p> <ul style="list-style-type: none"> • YY: Year of manufacture • WW: Week of manufacture • nnnn: Sequential number <p>Type</p> <ul style="list-style-type: none"> • 8 ASCII characters

10.3.17 Module 33: Version FPGA/i10w**Type**

Input module, 10 words

Description

This module can be used for querying the FPGA firmware version number of the device.

**NOTE**

If the value is not present in the device, a zero byte (0x00) is transmitted for each character.

Input values

Rel. Adr.	Description
0	<p>Displays the version number of the FPGA firmware as a string in the format V000.000.000.</p> <p>Type</p> <ul style="list-style-type: none"> • 12 ASCII characters
12	<p>Reserved</p> <p>Type</p> <ul style="list-style-type: none"> • 8 byte

10.3.18 Module 34: Version uC/i10w**Type**

Input module, 10 words

Description

This module can be used to query the version number of the firmware of the application processor of the device.

**NOTE**

If the value is not present in the device, a zero byte (0x00) is transmitted for each character.

Input values

Rel. Adr.	Description
0	Displays the version number of the firmware of the application processor of the device as a string in the format $\forall 000.000.000$. Type <ul style="list-style-type: none"> • 12 ASCII characters
12	Reserved Type <ul style="list-style-type: none"> • 8 byte

10.3.19 Module 35: Version uC2/i10w

Type

Input module, 10 words

Description

This module can be used to query the version number of the firmware of the communication processor.



NOTE

If the value is not present in the device, a zero byte (0x00) is transmitted for each character.

Input values

Rel. Adr.	Description
0	Displays the version number of the firmware of the communication processor as a string in the format $\forall 000.000.000$. Type <ul style="list-style-type: none"> • 12 ASCII characters
12	Reserved Type <ul style="list-style-type: none"> • 8 byte

10.4 Preset – moving to initialization position

The **Preset** function enables the measured distance value to be automatically adjusted to a reference value (preset) known to the system during commissioning, maintenance or device replacement.



NOTE

When activating the preset, the output of measured values of the distance sensor will be temporarily unavailable. We recommend carrying out the preset while the machine is at a standstill or running at very low speeds. The maximum activation number is typically around 10,000 cycles. The offset value calculated when activating the preset is permanently saved in the device.

You can run a static or dynamic preset. The static preset is triggered by the MF1 multifunction input. The dynamic preset is triggered via the PROFINET IO interface.

Static preset

You need the **20 Setup MFx** and **22 Setup Preset Static** modules to execute a static preset.

1. In module 20, set the **[Function MF1]** parameter to **[Input] Preset Static**.
2. In module 22, enter the desired initialization value in the **Distance Preset Static** parameter. The unit of the preset value corresponds to millimeters.
3. Drive the vehicle to the initialization position.
4. To do so, activate multifunctional input In1 / MF1, for exempling using a proximity switch, a photoelectric sensor or a switch.
5. The output value of the device corresponds to the set value for **Preset** at the initialization position.

Dynamic preset

To perform a dynamic preset, you need the **5 Distance/i2w, Preset Dyn/o2w** module.

1. Send the desired initialization value to the device via bits 0 to 29 of the output values. The unit of the preset value corresponds to the setting of the **Distance Resolution** parameter.
2. Drive the vehicle to the initialization position.
3. Trigger the **Preset** function via bit 31 of the output values.
4. The output value of the device corresponds at the initialization position to the initialization value from bits 0 to 29.



NOTE

By setting bit 30 in the **5 Distance/i2w, Preset Dyn/o2w**, module, the preset value and offset value are reset to the factory setting 0 mm. This is independent of whether a static preset was previously triggered via MF1 or a dynamic preset via module 5.

11 Maintenance

11.1 Cleaning



NOTICE

Equipment damage due to improper cleaning.

Improper cleaning may result in equipment damage.

- Only use recommended cleaning agents and tools.
- Never use sharp objects for cleaning.

- ▶ Clean the viewing window at regular intervals and in the event of contamination. First, remove any solid deposits with oil-free compressed air or, if necessary, with a mixture of water and a few drops of a commercially available rinsing agent and a soft brush, and then rinse. If required, remove the drying residue with cleaning cloths that are suitable for optics and plastic cleaning agent.

11.2 Maintenance plan

During operation, the device works maintenance-free.

Depending on the assignment location, the following preventive maintenance tasks may be required for the device at regular intervals:

Table 33: Maintenance plan

Maintenance work	Interval	To be carried out by
Check device and connecting cables for damage at regular intervals.	Depends on ambient conditions and climate.	Specialist
Clean housing and viewing window.	Depends on ambient conditions and climate.	Specialist
Clean the reflector and check it for damage.	Depends on the ambient conditions and company requirements.	Specialist
Check that the laser beam is directed at the center of the reflector.	Depends on the ambient conditions and company requirements. Recommended: At least every 6 months.	Specialist
Check the screw connections and plug connectors.	Depends on the place of use, ambient conditions or operating requirements. Recommended: At least every 6 months.	Specialist

12 Troubleshooting

12.1 General faults, warnings, and errors

General faults are subdivided into warnings and errors. Current measured values as well as respective warning messages continue to be output when there are warnings. Measurement is no longer possible when there are faults and measured value **0** and the respective error value are therefore output. If there is an error, the device continues to extrapolate measured values no later than when the error suppression time set in **ErrRej** expires. During this time, the **WrnPlb** plausibility warning is output. If measurement is still not possible after the error suppression time expires, measured value **0** and the associated error message are output.

Warnings and errors are signaled via the **PWR** LED and can be read in the main menu as long they are active. Warnings and errors can also be output via the multi-functional outputs or the fieldbus interface via the SOPAS ET configuration software. They are not stored on the device. **NoWrn** or **NoErr** is displayed in the main menu during fault-free operation.

The **PWR** LED signals the device status.



NOTE

Possible faults and corrective actions are described in the tables below for troubleshooting. In the case of faults that cannot be rectified using the description below, please contact the manufacturer. See the back page for relevant contact details.

12.2 Device status (LED PWR)

Table 34: LED status indicator

Display	Fault	Measures
The PWR LED does not light up.	No operation. Device is defective.	Check the supply voltage. Return the device for repairs.
The PWR LED flashes orange.	A warning is present.	For possible causes and correcting them see "Warning messages" , page 79.
The PWR LED flashes red.	An error is present.	For possible causes and correcting them see "Error messages" , page 80.

12.3 Warning messages

An active warning is indicated by an orange flashing **PWR** LED. The warning can be read in the main menu see ["Main menu"](#), page 32.

Table 35: Warning messages

Display in the main menu (meaning)	Possible causes	Troubleshooting
NoWrn	No warning	-

Display in the main menu (meaning)	Possible causes	Troubleshooting
WrnPlb (plausibility warning)	Measured value briefly not plausible. Light path between the measuring device and the reflector briefly interrupted.	Observe the light spot on the reflector. The light spot must not drift from the reflector. If necessary, realign the measuring device and reflector or use a larger reflector. For alignment and mounting see "Mounting", page 18.
	Measured value briefly not plausible. Optical interference is present, e.g. as a result of parallel mounted optical sensors.	<ul style="list-style-type: none"> Remove any optical interference see "Mounting", page 18.
WrnLsr (laser warning)	The measurement laser is still ready for operation but is at the end of its service life.	Keep a replacement device ready for use. It is advisable to replace the device during the next maintenance session.
WrnLvl (level warning)	Current attenuation value is beyond the error limit. For recommended attenuation values, see "Received signal level", page 28.	<ul style="list-style-type: none"> Align the device and reflector with each other, see "Aligning the distance sensor and reflector with each other", page 27. Clean the optical interfaces like the reflector and viewing window. Check the reflective tape for damage.
WrnTmp (temperature warning)	The internal device temperature is outside the range of -10 °C ... +75 °C. For the permissible ambient temperature see "Ambient data", page 84.	<ul style="list-style-type: none"> Check the ambient temperature. Provide better ventilation, if necessary. Shield the device from radiated heat, e.g. shade the measuring device from direct sunlight. At low ambient temperatures, use a heating system for the device. At high ambient temperatures, use a cooling housing.

12.4 Error messages

An active error is indicated by a red flashing PWR LED. The error can be selected in the main menu see "Main menu", page 32.

Table 36: Error messages

Display in the main menu (meaning)	Possible causes	Troubleshooting
NoErr	No errors	-

Display in the main menu (meaning)	Possible causes	Troubleshooting
ErrPlb (Plausibility error)	Measured value not plausible. Light path between the measuring device and the reflector interrupted.	Observe the light spot on the reflector. The light spot must not drift from the reflector. If necessary, realign the measuring device and reflector or use a larger reflector. For alignment and mounting see "Mounting" , page 18.
	Measured value not plausible. Measured value outside the permissible measuring range.	Check measurement range. If necessary, use device variant with high measuring range.
	Measured value not plausible. Optical interference is present, e.g. as a result of parallel mounted optical sensors.	Remove any optical interference see "Mounting" , page 18.
ErrLsr (Laser error)	The service life of the measurement laser has been exceeded.	Replace the device. It is advisable to replace the device during the next maintenance session.
ErrLvl (Level error)	Current signal attenuation is beyond the error limit see "Received signal level" , page 28.	<ul style="list-style-type: none"> ■ Align the distance sensor and reflector with each other see "Aligning the distance sensor and reflector with each other", page 27. ■ Clean the optical interfaces like the reflector and viewing window. ■ Check the reflective tape for damage.
ErrTmp (Temperature error)	The internal device temperature is outside the range of $-15\text{ °C} \dots +80\text{ °C}$. For the permissible ambient temperature see "Ambient data" , page 84.	<ul style="list-style-type: none"> ■ Check the ambient temperature. Provide better ventilation if necessary. ■ Shield the device from radiated heat, e.g. shade the measuring device from direct sunlight. ■ At low ambient temperatures, use a heating system for the device. ■ At high ambient temperatures, use a cooling housing.

12.5 Communication problems

12.5.1 Ethernet problems

Display	Status	Measures
Off	No physical connection (link) to the next participant available.	Check Ethernet wiring.

12.5.2 PROFINET faults

The BF/SF LEDs indicate the PROFINET status:

Table 37: BF/SF LEDs

BF/SF LEDs	Status	Measures
BF flashing red/ SF off	<ul style="list-style-type: none"> ● Device not configured correctly (e.g., station name, IP address). 	<ul style="list-style-type: none"> ● Check configuration.
BF red/SF off	<ul style="list-style-type: none"> ● No Ethernet connection. 	<ul style="list-style-type: none"> ● Check the wiring.

BF/SF LEDs	Status	Measures
BF off or flashing red/SF flashing red	<ul style="list-style-type: none"> PROFINET node flash test active. 	<ul style="list-style-type: none"> End the PROFINET node flash test.

12.6 Returns

- ▶ Only send in devices after consulting with SICK Service.
- ▶ The device must be sent in the original packaging or an equivalent padded packaging.



NOTE

To enable efficient processing and allow us to determine the cause quickly, please include the following when making a return:

- Details of the contact person
- Description of the application
- Description of the fault that occurred

12.7 Repairs

Repair work on the device may only be performed by qualified and authorized personnel from SICK AG. Interruptions or modifications to the device by the customer will invalidate any warranty claims against SICK AG.

12.8 Disposal



CAUTION

Risk of injury due to hot device surface.

The surface of the device can become hot.

- Before performing work on the device (e.g. mounting, cleaning, disassembly), switch off the device and allow it to cool down.
- Ensure good dissipation of excess heat from the device to the surroundings.

If a device can no longer be used, dispose of it in an environmentally friendly manner in accordance with the applicable country-specific waste disposal regulations. Do not dispose of the product along with household waste.



NOTICE

Danger to the environment due to improper disposal of the device.

Disposing of devices improperly may cause damage to the environment.

Therefore, observe the following information:

- Always observe the national regulations on environmental protection.
- Separate the recyclable materials by type and place them in recycling containers.

13 Technical data



NOTE

The relevant online product page for your product, including technical data, dimensional drawing, and connection diagrams, can be downloaded, saved, and printed from the Internet.

The page can be accessed via the **SICK Product ID: pid.sick.com/{P/N}/{S/N}**

{P/N} corresponds to the part number of the product, see type label.

{S/N} corresponds to the serial number of the product, see type label (if indicated).

Please note: This documentation may contain further technical data.

13.1 Optics

Table 38: Laser/optics

Light sender	Laser diode, red light
Laser class	2 (EN 60825-1:2014+A11:2021, IEC 60825-1:2014)
CW modulation	$\pm 0.85 P_0$ sinusoidally modulated
Maximum peak output	≤ 1.9 mW
Pulse duration	6.8 ns
Average performance P_0	< 1 mW
Shaft Length	655 nm
Frequency	≥ 90 MHz
Light spot size	Typically 5 mm + (2 mm x distance [m])
Average service life	Typically 100,000 h at +25 °C ambient temperature

13.2 Performance data

Table 39: Performance data

Measuring ranges	<ul style="list-style-type: none"> DL100-21XXXXXX: 0.15 m ... 100 m DL100-22XXXXXX: 0.15 m ... 200 m DL100-23XXXXXX: 0.15 m ... 300 m
Measuring object	On Diamond Grade reflective tape DG983
Measurement accuracy	<ul style="list-style-type: none"> DL100-21XXXXXX: ± 2.0 mm DL100-22XXXXXX: ± 2.5 mm DL100-23XXXXXX: ± 3.0 mm
Repeatability ²⁾	<ul style="list-style-type: none"> DL100-21XXXXXX: ± 0.50 mm DL100-22XXXXXX: ± 1.00 mm DL100-23XXXXXX: ± 2.00 mm
Measurement cycle time	1 ms
Response time/Measured value age	2 ms
output rate	1 ms
Initialization time	<ul style="list-style-type: none"> Typically 1.5 s After reflector loss: < 40 ms

¹⁾ The measurement accuracy can be up to ± 4 mm in the 150 mm...180 mm measuring range.

²⁾ Statistical error 1σ , environmental conditions constant, minimum warm-up time 10 min.

13.3 Supply

Table 40: Supply

Supply voltage V_S	18 V DC ... 30 V DC, reverse polarity protected
Current consumption (without load)	<ul style="list-style-type: none"> ■ Without heating: < 250 mA at 24 V DC ■ With heating: < 1,000 mA at 24 V DC
Residual ripple	< 5 V_{SS} within the permissible supply voltage U_V

13.4 Inputs

Table 41: Inputs

Inputs	<p>Multifunctional input MF1, switching function adjustable</p> <p>Switching type: Sink for PNP output (open input corresponds to the LOW input signal)</p> <ul style="list-style-type: none"> ■ HIGH > 12 V ■ LOW < 3 V
Circuit protection	None, no reverse-polarity protection.

13.5 Outputs

Table 42: Outputs

Outputs	<p>Multifunctional outputs MF1 and MF2, type B (push/pull), adjustable switching function</p> <ul style="list-style-type: none"> ■ HIGH > $U_V - 3 V$ ■ LOW < 2 V
Circuit protection	<ul style="list-style-type: none"> ■ Short-circuit protected ■ Overload-proof
Maximum output current	Max. 100 mA
Output load	<ul style="list-style-type: none"> ■ Capacitive: 100 nF ■ Inductive: 20 mH

13.6 Interfaces

Table 43: Interfaces

2x Ethernet	<ul style="list-style-type: none"> • Process data interface PROFINET IO/RT Conformance Class B, PN specification V2.3, Netload Class III • Configuration/Service interface (SOPAS ET)
--------------------	---

13.7 Ambient data

Table 44: Ambient data

Protection class	 <p>Suitable for operation in PELV (Protective Extra Low Voltage) systems with safe separation.</p>
Electromagnetic compatibility	EN 61000-6-2, EN 61000-6-4, Class A
Ambient operating temperature range	<p>-20 ... +55 °C ²⁾</p> <p>-40 ... +55 °C (with integrated heating) ³⁾</p> <p>-20 ... +75 °C (with cooler housing TPCC)</p>

Warehouse ambient temperature range	-40 ... +75 °C
Relative humidity	Max 95% (non-condensing)
Enclosure rating	IP 65
Effect of air pressure	0.3 ppm/hPa
Effect of temperature	1 ppm/K
Temperature drift	Typically 0.1 mm/K
Maximum traversing speed	15 m/s
Maximum acceleration	15 m/s ²
Mechanical strength	EN 60068-2-27 (Ea): Continuous shock: 25 g / 6 ms, half sine, 6 axes, 500 shocks per axis EN 60068-2-27 (Ea): Shock: 30 g / 6 ms, half sine, 6 axes, 3 shocks per axis EN 60068-2-64 (Fh): Broadband noise vibrations: 10 g rms, 10... 500 Hz, 6 axes, 2 h per axis

- 1) The device may cause interference if used in a residential environment.
- 2) A warm-up phase until activation of the laser diode is required for temperatures under -10 °C; typical duration at -20 °C: 20 min at 24 V.
- 3) For operation below -20 °C, a supply voltage of at least 24 V is required. A warm-up phase up until activation of the laser diode is required for temperatures under -10 °C: typical duration at -40 °C: 35 min at 24 V.
- 4) Maximum 95% humidity, non condensing

13.8 Structural design

Table 45: Structural design

Dimensions	see "Dimensional drawing", page 86
Weight	<ul style="list-style-type: none"> ■ Device: approx. 800 g ■ Alignment bracket (optional): approx. 800 g
Materials	<ul style="list-style-type: none"> ■ Housing: Cast aluminum GD-AISi12Cu1 (3.2982.05) ■ Viewing window: PMMA
Connections	<ul style="list-style-type: none"> ● M12, SpeedCon™-compatible
Display	<ul style="list-style-type: none"> ■ 6-digit with a 5 x 7 dot matrix

13.9 Dimensional drawing

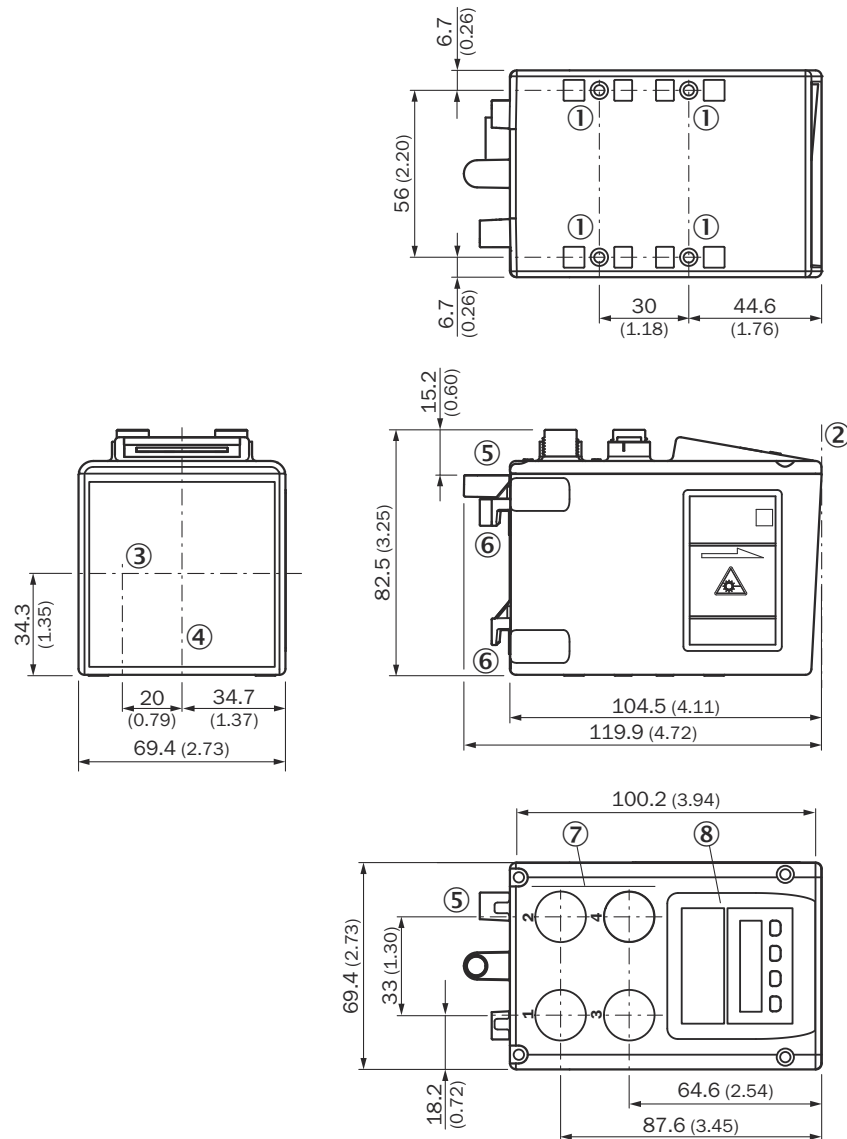

Figure 20: Device dimensions; unit: mm (inch), decimal separator: period

- ① Mounting thread M5, 10 mm depth
- ② Device zero point
- ③ Sender optical axis
- ④ Receiver optical axis
- ⑤ Hole for the star grip screw of the optional alignment bracket
- ⑥ Latch hook for alignment bracket
- ⑦ Electrical connection
- ⑧ Display and control elements

14 Accessories



NOTE

On the product page you will find accessories and, if applicable, related installation information for your product.

The page can be accessed via the SICK Product ID: pid.sick.com/{P/N}/{S/N}

{P/N} corresponds to the part number of the product, see type label.

{S/N} corresponds to the serial number of the product, see type label (if indicated).

14.1 Mounting systems

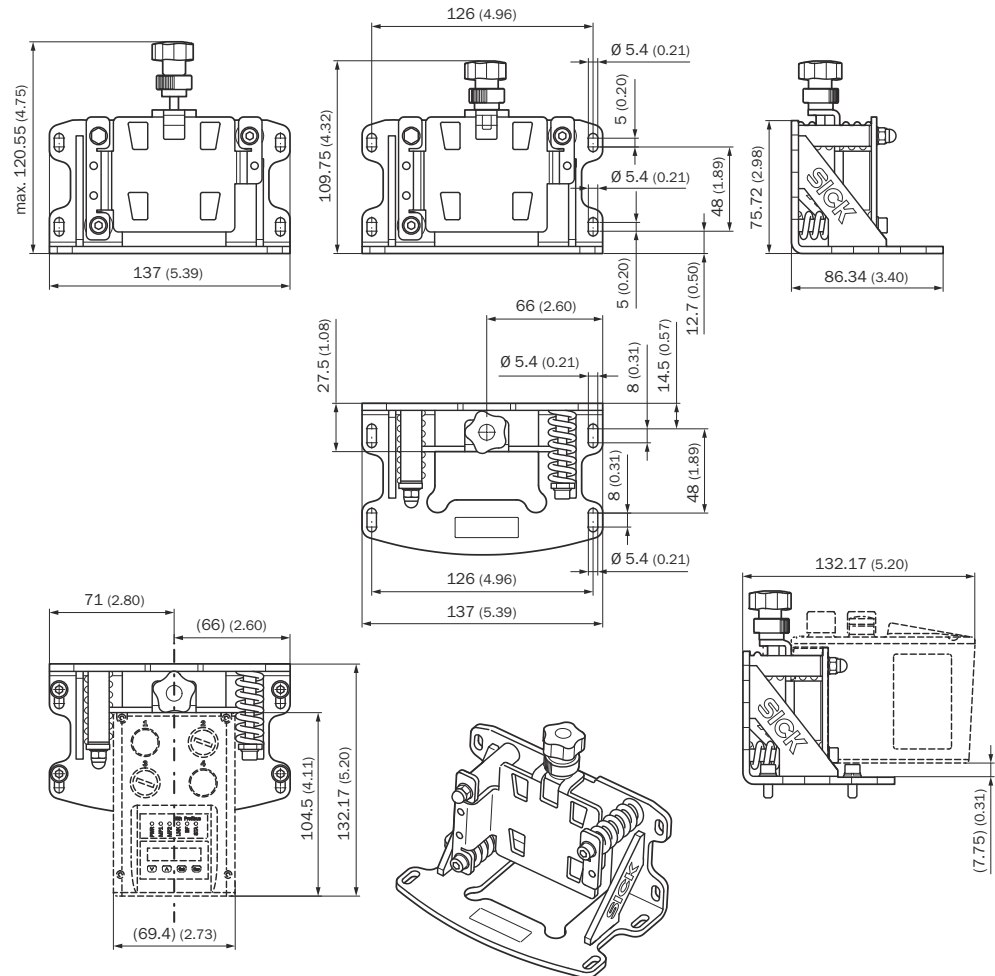

Figure 21: Alignment bracket; unit: mm (inch), decimal separator: period

Table 46: Alignment bracket

Description	Alignment bracket including fastening accessories
Type	BEF-AH-DX100
Part number	2058653
Material	Galvanized sheet steel

14.2 Cooler housing

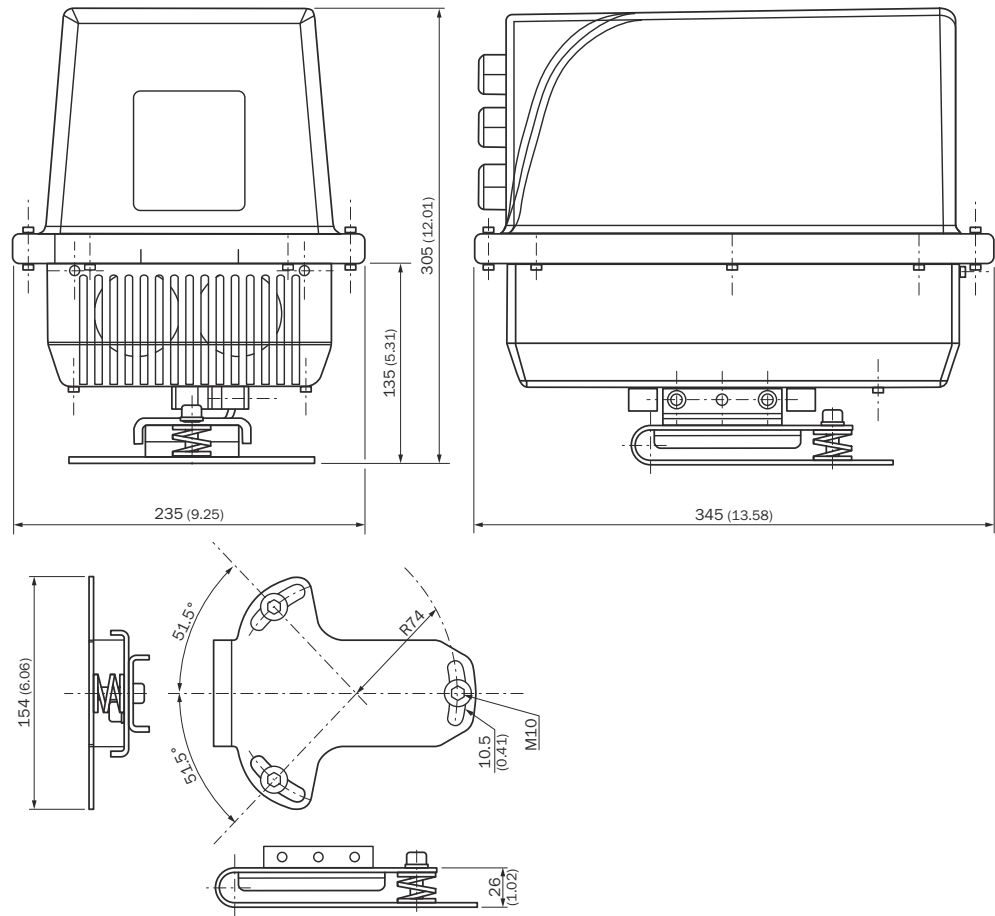

Figure 22: Cooler housing; unit: mm (inch), decimal separator: period

Table 47: Cooler housing

Description	Cooler housing including sensor-specific adapter plate and BEF-AH-DME alignment bracket (part number: 2027721)
Type	TPCC-Dx100
Part number	6048328
Material	Plastic (polyamide 6)
Weight	7.5 kg
Ambient temperature, operation	-40 ... +75 °C (+80 °C for max. 1 h)
Ambient temperature storage	-40 ... +50 °C
Supply voltage	24 ... 30 V DC
Current consumption	11 A at 24 V DC; start-up current max. 15 A at 24 V DC
Enclosure rating	IP55 (horizontal mounting) IP54 (vertical mounting)

15 Annex

15.1 Menu structure

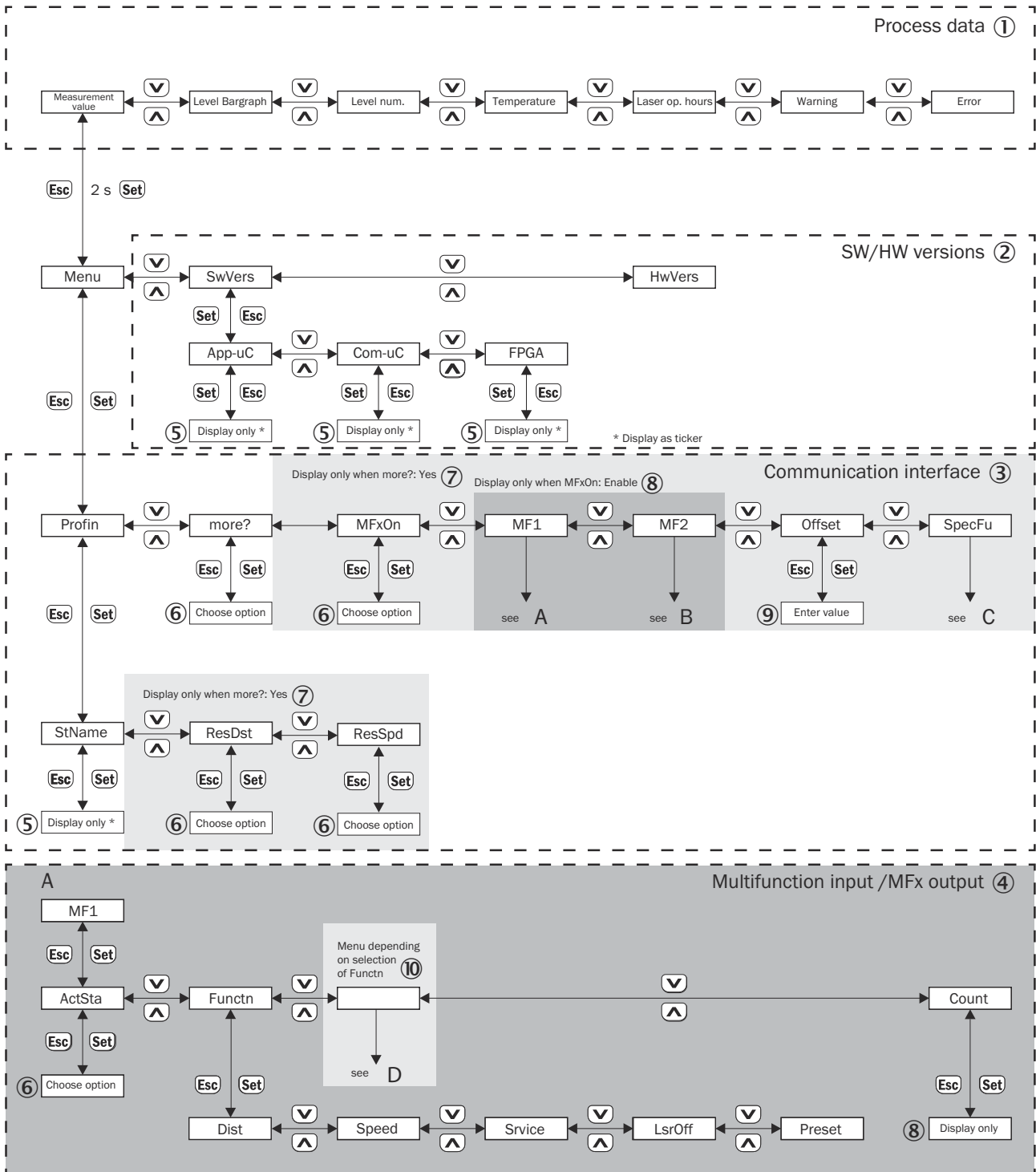

- ① Process data
- ② Software and hardware versions
- ③ Interface
- ④ Multifunctional input/multifunctional outputs
- ⑤ Indication only

- ⑥ Select option
- ⑦ Only displayed if **more?** = **Yes**
- ⑧ Only displayed if **MFxOn** = **Enable**
- ⑨ Adjust the value
- ⑩ The menu displayed depends on the selected function (**Func^{tn}**) see D

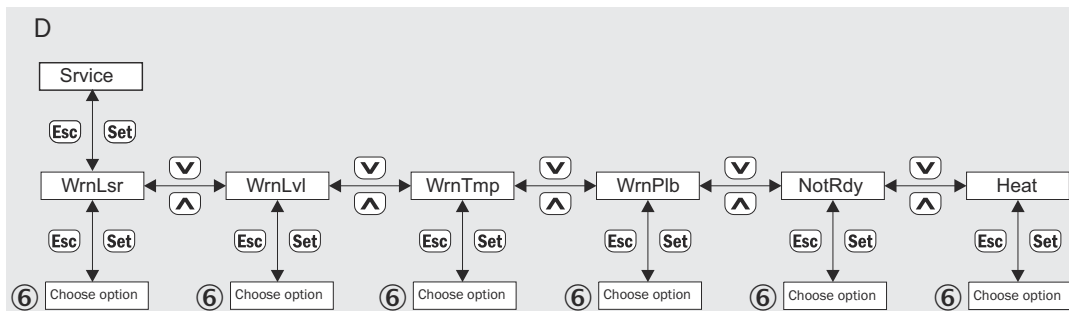
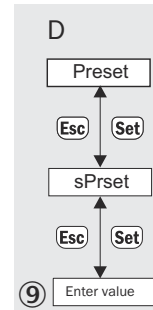
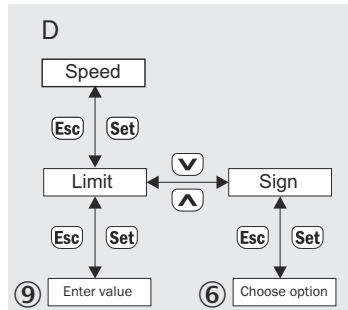
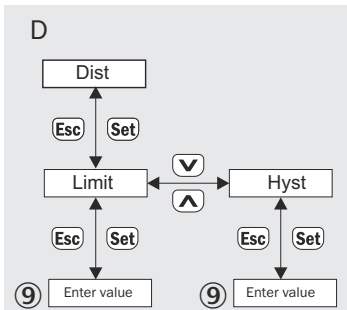
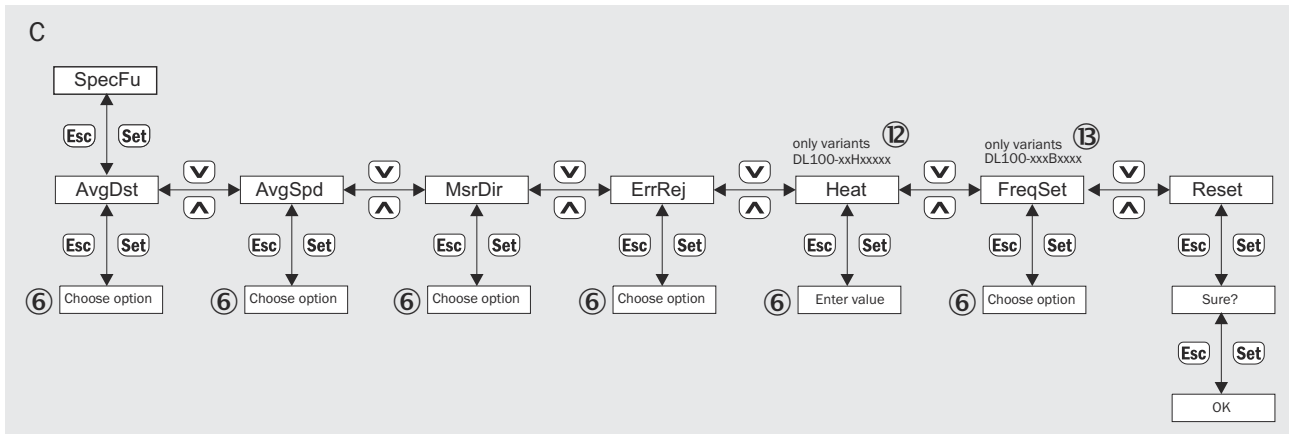
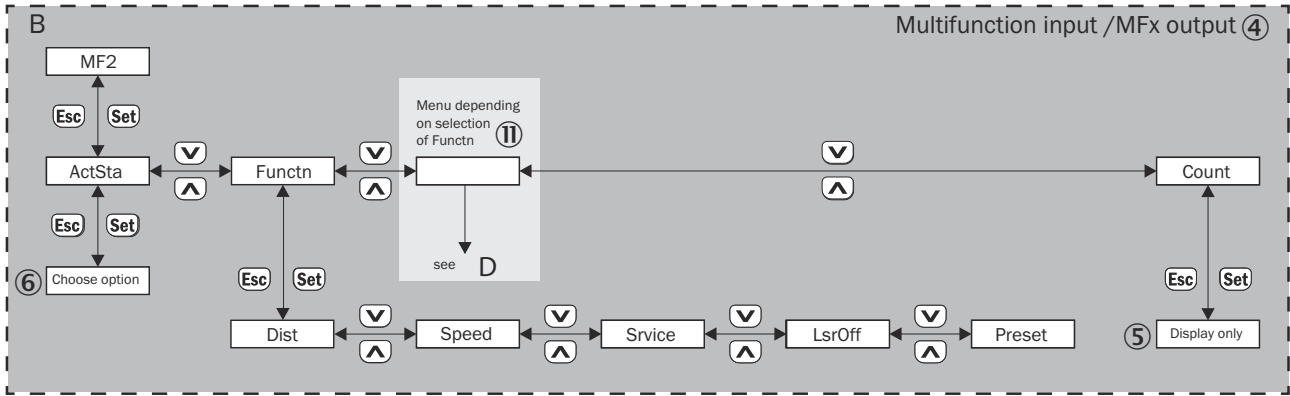

- ④ Multifunctional input/multifunctional output
- ⑤ Display the value
- ⑥ Selecting an option
- ⑨ Adjust the value
- ⑪ The menu displayed depends on the selected function (Functn) see D
- ⑫ For the variants DL100-xxHxxxx only

③ For the variants DL100-xxxBxxxx only

15.2 Declarations of conformity and certificates

You can download declarations of conformity and certificates via the product page.

The page can be accessed via the **SICK Product ID: pid.sick.com/{P/N}/{S/N}**

{P/N} corresponds to the part number of the product, see type label.

{S/N} corresponds to the serial number of the product, see type label (if indicated).

Australia

Phone +61 (3) 9457 0600
1800 33 48 02 – tollfree
E-Mail sales@sick.com.au

Austria

Phone +43 (0) 2236 62288-0
E-Mail office@sick.at

Belgium/Luxembourg

Phone +32 (0) 2 466 55 66
E-Mail info@sick.be

Brazil

Phone +55 11 3215-4900
E-Mail comercial@sick.com.br

Canada

Phone +1 905.771.1444
E-Mail cs.canada@sick.com

Czech Republic

Phone +420 234 719 500
E-Mail sick@sick.cz

Chile

Phone +56 (2) 2274 7430
E-Mail chile@sick.com

China

Phone +86 20 2882 3600
E-Mail info.china@sick.net.cn

Denmark

Phone +45 45 82 64 00
E-Mail sick@sick.dk

Finland

Phone +358-9-25 15 800
E-Mail sick@sick.fi

France

Phone +33 1 64 62 35 00
E-Mail info@sick.fr

Germany

Phone +49 (0) 2 11 53 010
E-Mail info@sick.de

Greece

Phone +30 210 6825100
E-Mail office@sick.com.gr

Hong Kong

Phone +852 2153 6300
E-Mail ghk@sick.com.hk

Hungary

Phone +36 1 371 2680
E-Mail erteakesites@sick.hu

India

Phone +91-22-6119 8900
E-Mail info@sick-india.com

Israel

Phone +972 97110 11
E-Mail info@sick-sensors.com

Italy

Phone +39 02 27 43 41
E-Mail info@sick.it

Japan

Phone +81 3 5309 2112
E-Mail support@sick.jp

Malaysia

Phone +603-8080 7425
E-Mail enquiry.my@sick.com

Mexico

Phone +52 (472) 748 9451
E-Mail mexico@sick.com

Netherlands

Phone +31 (0) 30 204 40 00
E-Mail info@sick.nl

New Zealand

Phone +64 9 415 0459
0800 222 278 – tollfree
E-Mail sales@sick.co.nz

Norway

Phone +47 67 81 50 00
E-Mail sick@sick.no

Poland

Phone +48 22 539 41 00
E-Mail info@sick.pl

Romania

Phone +40 356-17 11 20
E-Mail office@sick.ro

Singapore

Phone +65 6744 3732
E-Mail sales.gsg@sick.com

Slovakia

Phone +421 482 901 201
E-Mail mail@sick-sk.sk

Slovenia

Phone +386 591 78849
E-Mail office@sick.si

South Africa

Phone +27 10 060 0550
E-Mail info@sickautomation.co.za

South Korea

Phone +82 2 786 6321/4
E-Mail infokorea@sick.com

Spain

Phone +34 93 480 31 00
E-Mail info@sick.es

Sweden

Phone +46 10 110 10 00
E-Mail info@sick.se

Switzerland

Phone +41 41 619 29 39
E-Mail contact@sick.ch

Taiwan

Phone +886-2-2375-6288
E-Mail sales@sick.com.tw

Thailand

Phone +66 2 645 0009
E-Mail marcom.th@sick.com

Turkey

Phone +90 (216) 528 50 00
E-Mail info@sick.com.tr

United Arab Emirates

Phone +971 (0) 4 88 65 878
E-Mail contact@sick.ae

United Kingdom

Phone +44 (0)17278 31121
E-Mail info@sick.co.uk

USA

Phone +1 800.325.7425
E-Mail info@sick.com

Vietnam

Phone +65 6744 3732
E-Mail sales.gsg@sick.com

Detailed addresses and further locations at www.sick.com