

MKAS
Multi-component Analysis System



Installation
Operation
Maintenance



Document Information

Described Product

Product name: MKAS

Document ID

Title: Operating Instructions MKAS
Part No.: 8013230
Version: 1.1
Release: 2012-07

Manufacturer

SICK AG
Erwin-Sick-Str. 1 · 79183 Waldkirch · Germany
Phone: +49 7641 469-0
Fax: +49 7641 469-1149
E-mail: info.pa@sick.de

Original Documents

The English edition 8013230 of this document is an original document of SICK AG.

SICK AG assumes no liability for the correctness of an unauthorized translation.

Please contact the manufacturer or your local representative in case of doubt.

Legal information

Subject to change without notice.

© SICK AG. All rights reserved.

Glossary

Wiring diagram: Optionally comprising wiring plan, terminal diagram, gas flow diagram, parts list, view drawings, graphic wiring and function diagram for LOGO!/ PLC logic control.

LWL Module: Fiber optics module

DAU: Data acquisition unit (DAU), acquisition of measured data, editing and transmission to the emission PC. Alternatively, the use of field modules is possible for smaller applications.

EPC: Emissions PC with "Windows XP" operating system. Optional connection of up to 16 devices (DAU, field modules, Modbus, OPC etc.). Receiving/sending of data from/to a process control system possible.

MEAC 2000 software: Processing, storage and representation of all calculated values. Operation in Windows standard. Optional display of data in local network possible.

Control: A LOGO! small control system or a PLC control can be optionally used as analyzer cabinet control.

PLC: (Program Logic Controller)

LOGO!: Small control system from the Siemens AG.

Cabinet cooling unit: Referred to as cabinet climate control (air conditioner).

Sample gas probe: Gas sampling probe / probe

Sample gas line: Heating hose / analysis hose

LEL: Lower Explosion Limit (minimum concentration in a combustible gas or steam above which the gas mixture can be ignited)

UPS: Uninterrupted Power Supply

Raschig rings: Raschig rings are used as filling in gas washers.

CAN Bus: Control Area Network. A field bus.

NOx converter: Gas converter (referred to as NO₂ / NO converter.)

CompactFlash® disc: Memory card.

Ethernet: Computer networking technology. Basis for network protocols, such as TCP/IP.

ESD: Electrostatic Discharge

Fieldbus: An industrial communication system to connect a variety of field equipment such as analyzers, measuring sensors, actuators and drives with a control unit.

Firewall: Safety concept of software and hardware components to restrict access to computer networks.

Modbus®: Field bus communication protocol

PROFIBUS®: Field bus communication protocol

OLE: Object Linking and Embedding. Standardized data interface (Microsoft Corporation)

OPC: Openness, Productivity, Collaboration. Standardized data interface (OPC Foundation).

Span gas: Test gas with a concentration of approx. 75% of the upper measuring range limit.

SOPAS: (SICK Open Portal for Applications and Systems): SICK Parameter Setting and Data Calculation Software.

SOPAS ET: SOPAS PC Engineering Tool. Configuration protocol.

TCP/IP: Network protocol.

Warning Symbols



Hazard (general)



Hazard by voltage



Hazard by corrosive substances



Hazard by toxic substances



Hazard by explosive substances/mixtures



Hazard by high temperature or hot surface



Hazard for the environment/nature/organic life

Information Symbols



Important technical information for this product



Important information on electrical or electronic functions



Nice to know



Supplementary information



Link to information at another place

Warning levels / Signal words

DANGER

Risk or hazardous situation which *will* result in severe personal injury or death.

WARNING

Risk or hazardous situation which *could* result in severe personal injury or death.

CAUTION

Hazard or unsafe practice which *could* result in personal injury or property damage.

NOTICE

Hazard which *could* result in material damage.

1	Important Information	7
1.1	Intended use	8
1.1.1	Purpose of the device	8
1.1.2	Application limitations	8
1.2	Responsibility of user	8
1.3	Additional documentation/information	9
2	Product Description	11
2.1	Product identification	12
2.2	Characteristics	12
2.2.1	System overview	12
2.2.2	Method of operation	13
2.2.3	Internal functional units of the MKAS analysis system	13
2.2.4	External functional units	14
2.2.5	Measuring components	14
2.3	Interfaces	15
2.4	Description of subassemblies	16
2.4.1	Exterior view	16
2.4.2	Interior view (swivel frame)	17
2.4.3	Interior view (with swivel frame open)	18
2.4.4	Parts list	18
2.5	Gas flow plan	19
3	Preparation for Initial Start-up	21
3.1	Scope of delivery	22
3.2	Project planning and installation information	22
3.2.1	Preparation of installation location	22
3.3	Transport and installation	23
3.4	Removing transport safety devices	23
3.5	Checking attachments and connections	23
3.6	Inserting filter elements and bubbling frits (option)	23
3.7	Inserting the NOx converter cartridges (option)	24
3.8	Preparing for start-up of gas sampling probes	24
3.9	Gas lines	25
3.10	Preparing the electrical installation	27
3.10.1	View of cable ducts on the control cabinet (symbolic)	27
3.10.2	Preparation of mains supply	27
3.10.3	External components and signal generators	28
3.11	Connecting to the customer plant	28
3.11.1	Integration of the MKAS analysis system in the customer plant	28
3.11.2	Data evaluation (external interfaces)	28

4	Start-up	29
4.1	Persons authorized to carry out start-up	30
4.2	Start-up of washing bottles / humidifier containers (option).....	30
4.3	Adsorption pads (option)	30
4.4	Before switching on	31
4.5	Switching on the MKAS analysis system	31
4.6	Start-up for the sample gas cooler (option).....	31
4.7	Start-up for the analyzer (SIDOR; S710).....	32
4.8	Start-up for the NO _x converter (option).....	32
4.9	Start-up for the DAU (MEAC2000 connection) (option)	32
4.10	Start-up for the cabinet climate control (option)	33
4.11	Start-up for the gas warning system (option)	34
4.12	Start-up for the heated gas sampling probe	34
4.13	Restarting after longer shutdown	35
5	Operation	37
5.1	Operation of system components	38
5.2	Layout and functions of system components	38
5.3	System Parameters.....	38
6	Adjusting	39
6.1	When is adjustment necessary?	40
6.2	Basic variants of the adjustment procedure.....	40
6.3	Performing the adjustment procedure	40
6.4	Adjusting (or possible calibration) external components and signal generators	40
7	Shutdown	41
7.1	General information	42
7.2	Standby operation (Maintenance mode)	42
7.3	Switch-off procedure / switching off	42
7.3.1	Safety measure: Secure connected locations	42
7.3.2	Safety measure: Completely remove the sample gas	43
7.3.2.1	When measuring toxic, dangerous or wet gases.....	43
7.3.2.2	When measuring harmless gases.....	44
7.3.3	Switch off	44
7.4	Shutdown.....	45
7.5	Storage.....	45
7.6	Disposal.....	46

8	Maintenance	47
8.1	Important maintenance information	48
8.2	Maintenance signal (Maintenance mode).....	49
8.3	Visual inspection / function control	49
8.4	Description of maintenance work	50
8.4.1	Maintenance recommendations / maintenance intervals	50
8.5	Cleaning information	52
8.6	Recommended spare parts (SP) / wearing parts (WP).....	52
8.6.1	SP/WP for internal components	52
8.6.2	SP/WP for external components	57
8.7	Further and supplementary spare/wearing parts	58
9	Clearing Malfunctions	59
9.1	Fuses	60
9.2	Status indicators / group alarms	60
9.3	Implausible measuring results.....	60
9.4	Switch-on conditions / additions to clearing malfunctions.....	61
10	Specifications	63
10.1	Compliances.....	64
10.1.1	Electrical protection.....	64
10.2	Dimensions.....	64
10.3	Technical Data	65

MKAS

1 Important Information

Main operating information
Intended use
Own responsibility

1.1 Intended use

1.1.1 Purpose of the device

The MKAS is a multi-component analysis system designed for continuous flue gas and emission monitoring for industrial combustion plants and processes.

The sample gas is taken from a sampling point and feed through the gas analyzer (extractive measurement).

1.1.2 Application limitations



WARNING: Risk of explosions

!▶ Do not operate the device in potentially explosive atmospheres.



WARNING: Risk of explosions when explosive sample gas is used

Risk of explosions when the gas path is not gas-tight.

▶ Do not deactivate the detonation flame arrester function integrated in the system when using the MKAS analysis system to measure explosive gases (sample gas inlet and outlet).

1.2 Responsibility of user

Intended users

The MKAS may only be installed and put into operation by skilled persons who, based on their technical training and knowledge as well as knowledge of the relevant regulations, can assess the tasks given and recognize the dangers involved.

Correct use

- ▶ Use the device only as described in these Operating Instructions. The manufacturer bears no responsibility for any other use.
- ▶ Carry out the specified maintenance work.
- !▶ Do not remove, add or change any components in or on the device unless such changes are officially allowed and specified by the manufacturer. Otherwise
 - the manufacturer's guarantee becomes invalid
 - the device could become dangerous

Special local conditions

- ▶ Follow all local laws, regulations and company-internal operating directives applicable at the installation location of the equipment.

Responsibility for dangerous sample gases



WARNING: Mortal/health danger as a result of a gas path leakage

When the device measures toxic gases: A leak in the gas path can cause acute danger for persons.

- ▶ Take suitable safety measures.
- ▶ Make sure these safety precautions are followed.

Keeping documents

These Operating Instructions:

- ▶ Must be available for reference.
- ▶ Must be passed on to new owners.

1.3

Additional documentation/information

The following documents are applicable in addition to these Operating Instructions:

Instructions delivered with the system

- Operating Instructions, analyzer (s) (e.g.: SIDOR, S700)
- Electronic Device Passport, analyzer(s) (e.g.: SIDOR, S700)
- Wiring diagram, MKAS analysis system (control cabinet)

System component instructions accompanying the System Documentation

Supplementary instructions (optional):

- Operating Instructions, sampling probe (option)
- Operating Instructions / Data Sheets, sample gas line (option)
- Operating Instructions of the supply unit / components for temperature control of external (heated under control) sample gas line (option)
- Operating Instructions, NOx converter (option)
- Operating Instructions / Data Sheets for the components for sample gas conditioning and test gas feeding, such as:
 - Sample gas pump
 - Sample gas cooler (including condensate pump)
 - Test gas valves (solenoid valves)
 - Washing bottles (option)
 - Humidifier container (zero gas humidification) (option)
 - Sample gas monitoring (flow, moisture)
 - Water traps (humidity separator)
 - Cylinder pressure reducer
- Operating Instructions / Data Sheets for the system control, such as:
 - LOGO! / Logic module (option)
 - PLC control (option)
- Operating Instructions / Data Sheets for components of the control cabinet climate control and lighting, such as.:
 - Control cabinet cooler (option)
 - Antifreeze heater (option)
 - Cabinet fan (option)
 - Control cabinet light
- Operating Instructions / Data Sheets for components supplementing the system (option)
- Operating Instructions / Data Sheets for gas warning systems to monitor toxic gases and the LEL (option), such as:
 - Gas monitor / Gas measurement computer
 - Visual and acoustic signal reporting devices
- Data Sheets for additional components for power supply / mains supply and (electr.) protection devices, such as:
 - Transformers (option)
 - Lightning protection / overvoltage element (option)
- Operating Instructions for modules for measured value computer connection (option)
- Project-specific measured data recording and processing
 - Operating Instructions, MEAC2000 (option) (including data acquisition unit / DAU)
 - Data Sheet, computer hardware (emission PC / EPC) (option)

MKAS

2 Product Description

Product identification

Functional principle

Characteristics

2.1 Product identification

Product name	MKAS
Manufacturer	SICK AG Erwin-Sick-Str. 1 · 79183 Waldkirch · Germany

The type plate is normally located at the top on the right cabinet side.

The type plate can however be located somewhere else on special versions.



It is possible that your MKAS has a different configuration to that described in this manual.

- ▶ Refer to the System Documentation (→ page 9, § 1.3) delivered with your MKAS for the individual configuration of your system.

2.2 Characteristics

The multi-component analysis system MKAS is an analysis system to measure and monitor gaseous components.

The MKAS works extractive, i.e. the gas to be measured is taken from the gas duct using a gas extraction probe or probes and fed to the analysis system via (heated) sample gas line(s).

Refer to the wiring diagram, system overview and the delivered system records and documents for individual system-specific equipment or the project-specific version of the overall MKAS analysis system.

2.2.1 System overview

The system overview can be seen in, or derived from the System Documentation as well as the wiring diagram.

2.2.2 Method of operation

Fig. 1 MKAS functional principle (example)

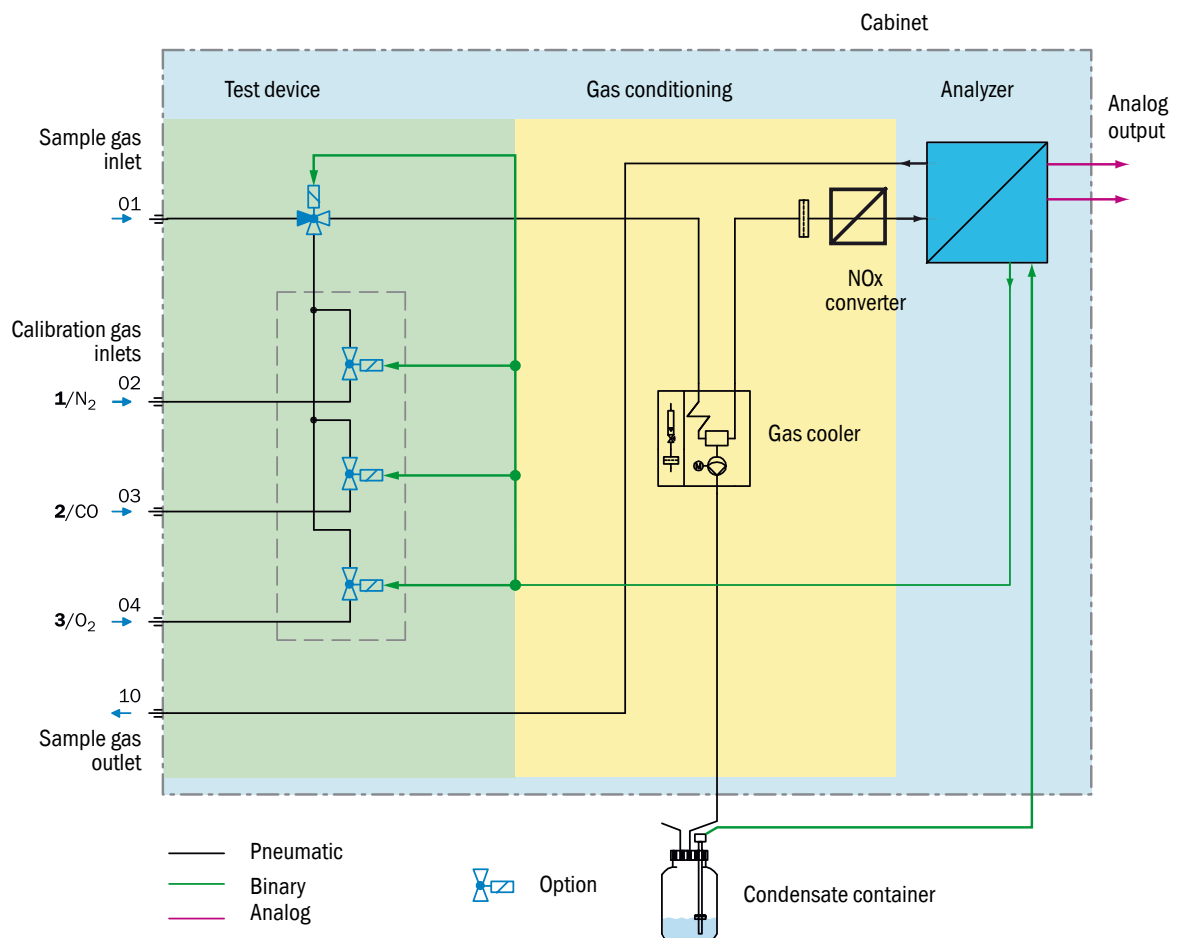

2.2.3 Internal functional units of the MKAS analysis system

- Components for supply / regulation of heated (external) sample gas lines and heated gas sampling probes (option)
- Sample gas delivery unit comprising:
 - Sample gas pump(s)
 - Control valve(s) / needle valve(s) (option)
 - Flowmeter (option)
- Sample gas conditioning comprising:
 - Sample gas cooler(s) (optional with: Flowmeter and needle valve, condensate pump, filter, moisture sensor)
 - Sample gas filter(s) (option)
 - Washing bottles / gas washer (option)
 - Absorption pad(s) (option)
 - Condensate pump(s) (option)
 - Condensate collection container with level monitor
 - Water trap(s)
 - Liquid alarm sensor(s) after the cooler (option)
 - Sample gas monitoring (flow, moisture)

- Span gas / test gas feed unit comprising:
 - Solenoid valves
 - Humidifier container (option)
 - Absorption pad(s) (option)
 - Drying pad(s) (option)
- Analyzer(s)
- (NO_x) Sample gas converter (option)
- Terminal strips for connection/interfaces by customer
- Interface modules (option)
- Data acquisition unit
 - “DAU” (option)
 - “Signal converter modules” (option)
- Connection for measured value computer (option) via field modules, such as:
 - Analog input modules (2 channels; 0...8)
 - Digital input modules (4 channels; 0...8)
 - Analog output modules (2 channels; 0...8)
 - Digital output modules (4 channels; 0...8)
 - Field module - EPC connection RS422 / RS485
- Gas warning device / systems (option)

2.2.4

External functional units

- Gas sampling probe(s) (option)
- Backflush unit(s) for gas sampling probe(s) (option)
- Sample gas line(s) (option)

External components supplementing the system

- Temperature sensors (option, for temperature measurement)
- Pressure sensors (option, for pressure measurement)
- Gas speed measuring devices (option)
- Dust measuring devices (option)
- Other project-specific peripherals (option)



The external functional units are project / system-specific. Refer to the wiring diagram as well as the System Documentation for details.

2.2.5

Measuring components

Possible measuring components ^[1]	CO, NO, SO ₂ , CO ₂ , H ₂ , CH ₄ , O ₂ and others
--	--

[1] Depending on built-in analyzer and equipment of the MKAS system

Refer to the Electronic Device Passport of the analyzer and the wiring diagram of the MKAS analysis system for system-specific details and information on the measuring components.

2.3

Interfaces

- Measured value, status and control outputs
 - Measured value outputs (analog), freely selectable (0 / 2 / 4 ... 20 mA linear)
 - Status and control outputs
- Measured value and control inputs
 - Measured value inputs (analog)
(0 / 2 / 4 ... 20 mA or 0 ... 10V)
- Digital interfaces (option)
 - RS232
 - RS422
 - RS485
- Bus interfaces / Fieldbus modules (option)
 - Modbus
 - Profibus
- LWL modules (option)
- Voltage supply (system-specific)
 - 400V, 50Hz
 - 400V, 60Hz
 - 230V, 50Hz
 - 230V, 60Hz
 - 115V, 50Hz
 - 115V, 60Hz
- UPS connection / supply (option)

2.4 Description of subassemblies

2.4.1 Exterior view

Refer to the wiring diagram of the MKAS analysis system for the specific exterior view.
A typical layout for an MKAS system is shown in the following. This layout can vary specific to the system.

Fig. 2 Exterior view (without air conditioner)

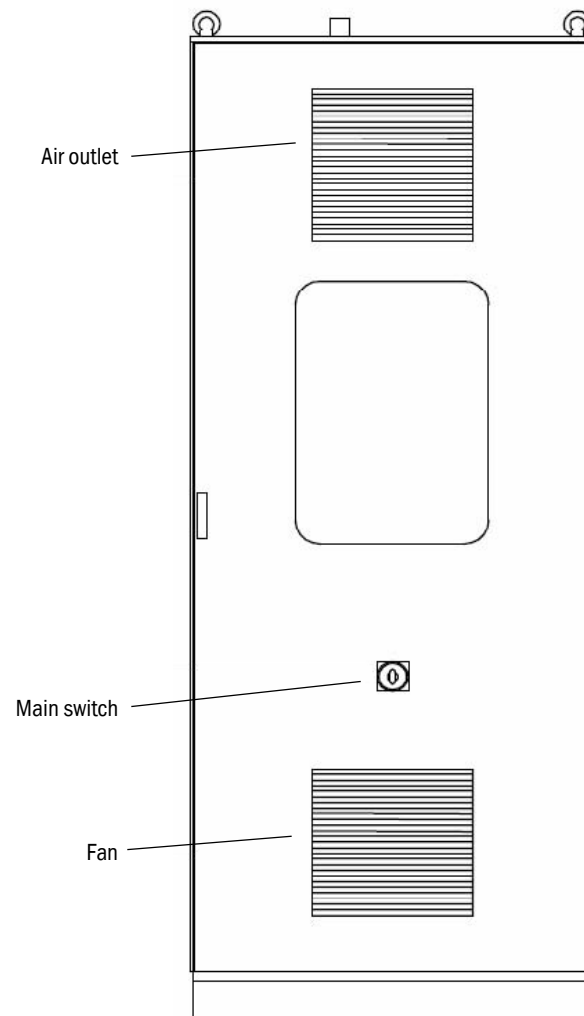

- The layout can vary specific to the system.

2.4.2 Interior view (swivel frame)

Refer to the wiring diagram of the MKAS analysis system for the specific interior view (swivel frame).

A typical layout for an MKAS system is shown in the following.

This layout can vary specific to the system.

Fig. 3

Swivel frame

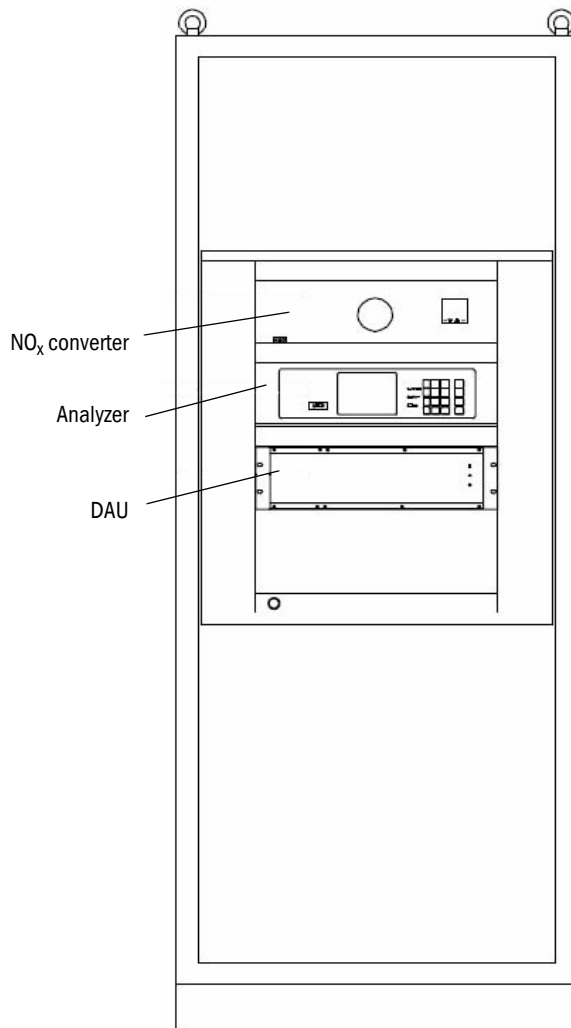

- The layout can vary specific to the system.

2.4.3 **Interior view (with swivel frame open)**

Refer to the wiring diagram of the MKAS analysis system for the specific interior view with open swivel frame or without swivel frame.

A typical layout for an MKAS system is shown in the following. This layout can vary specific to the system.

Fig. 4 Swivel frame open

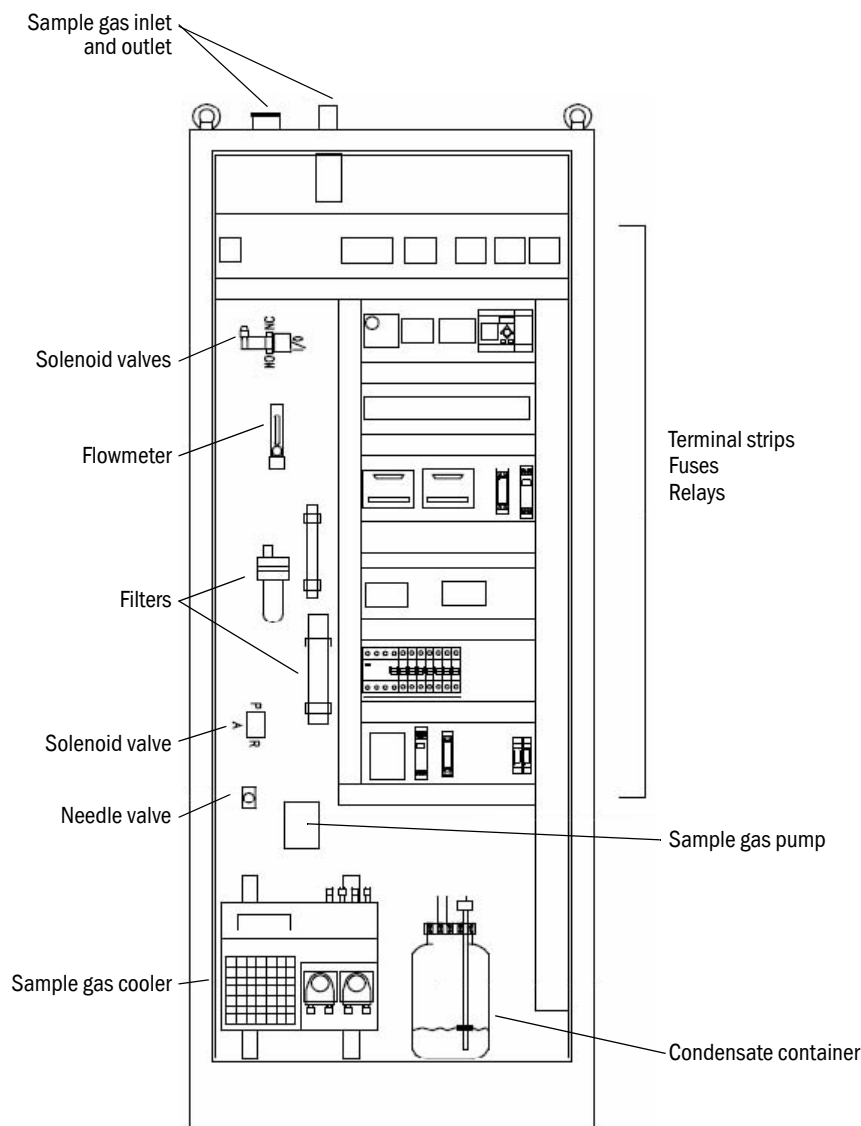

- The layout can vary specific to the system.

2.4.4 **Parts list**

Refer to the wiring diagram of the MKAS analysis system for the system-specific parts list of the system components.

2.5

Gas flow plan

- ▶ Refer to the wiring diagram of the MKAS analysis system for the system-specific gas flow plan.

A typical layout for an MKAS variant with sample gas line and span gas feed to the sample gas probe is shown in the following. This layout as well as the variants can vary specific to the system.

- The layout can vary specific to the system.
- The names of the system components can vary specific to the system.
- Refer to the system-specific wiring diagram or the parts list contained therein for the applicable names.

Fig. 5 Typical flow plan with sample gas line and span gas feed to the sample gas probe

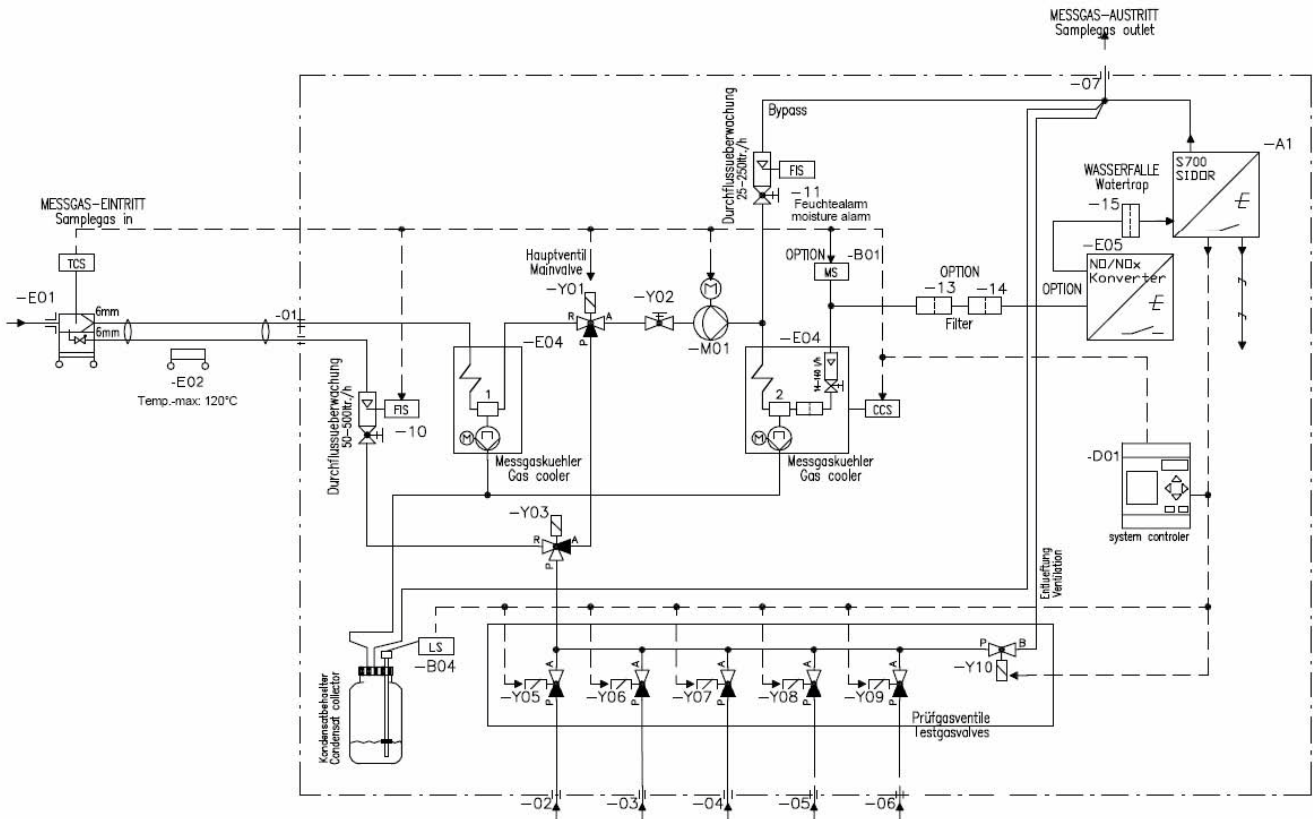

FIS = flow indicator system / Durchfluss Überwachung
 TCS = temp. control system / Temperaturregelung
 CCS = cooler control system / Kühlerüberwachung
 LS = level sensor / Füllstandüberwachung
 MS = moisture sensor / Feuchtesensor

NULLGAS 1 Zerogas 1	PRUEFGAS 1 Spangas 1	PRUEFGAS 2 Spangas 2	PRUEFGAS 3 Spangas 3	NULLGAS 2 Zerogas 2
------------------------	-------------------------	-------------------------	-------------------------	------------------------

System elements legend		
Name	Description	
A1	Analyzer	Use / Quantity / Type = optional
B04	Condensate collection container with level switch	
D01	System control	
E01	Gas sampling probe	Provision / Type = optional
E02	Sample gas line	Provision / Type = optional
E04	Sample gas cooler	Type = optional
E05	NO _x converter	Use / Quantity / Type = optional
M01	Sample gas pump	Type = optional
Y01	Main valve	Type = optional
Y02	Locking / variator valve	Use / Type = optional
Y03	Test gas feed valve (for test gas feeding to the probe)	Use / Type = optional
Y05..Y09	Test gas valves	Use / Quantity / Type = optional
Y10	(Test gas) vent valve	Type = optional
07	Sample gas outlet (collector)	
10	Flow monitoring (for test gas feeding to the probe)	Use / Quantity / Type = optional
11	Flow monitoring (bypass)	Use / Quantity / Type = optional
13/14	Filter	Use / Quantity / Type = optional
15	Water trap	

MKAS

3 Preparation for Initial Start-up

Installation
Assembly

3.1 **Scope of delivery**

Please see the delivery documents for the scope of delivery.

3.2 **Project planning and installation information**

3.2.1 **Preparation of installation location**



NOTICE:

- ▶ Connection to the gas supply may only be performed by skilled persons who, based on their technical training and knowledge as well as knowledge of the relevant regulations, can assess the tasks given and recognize the hazards involved.

The operator is responsible for preparing the installation location.

- Pay attention to the ambient conditions (→ „Technical Data“).
(Conditions: Under a roof or protected against direct heat radiation, heavy dust loads and corrosive atmospheres).
- Cabinet dimensions (refer to the view drawings / wiring diagram in the System Documentation).
- Ensure adequate load carrying capacity of the floor (minimum 550 kg/m²).
- Install the MKAS measuring system in an environment almost free from vibrations. Vibrations can influence measurement and therefore, in case of doubt, plan onsite vibration damping.
- Install the MKAS measuring system as close as possible to the measuring point.
 - Short sample gas lines mean short T-90 times.
Max. sample gas line length: 35 m
(longer sample gas line are possible under certain conditions. The components of the MKAS analysis system must be planned accordingly).
 - ▶ Observe the information in the assembly guidelines for fitting heating hoses.
- Installation location for the span gas cylinders. (Option! Only when span gas cylinders are used).
Provide a suitable installation location for the span gas cylinders.
Note:
 - Observe local provisions governing gas cylinder installation.
 - Provide a suitable installation location for the pressure regulator unit.
- Provide a suitable installation location for the instrument air conditioning system (option).
- Air outlet of the control cabinet ventilation / climate control
 - ▶ Do not block the air outlet of the control cabinet ventilation or the cabinet climate control of the MKAS analysis cabinet.
- Provide (individual) attachments for the system cabinet.
- For installation on gratings: Parts could drop or liquids (e.g. condensate) could drip and cause injuries. Provide a suitable base plate.

3.3 Transport and installation



NOTICE:

- ▶ The MKAS analysis system may only be transported and installed by skilled persons who, based on their training and knowledge as well as knowledge of the relevant regulations, can assess the tasks given and recognize the dangers involved.

- ▶ Only use suitable hoisting equipment (e.g. crane) to install the MKAS (weight approx. 250 to 350 kg).
- ▶ Observe the current applicable MKAS analysis cabinet transport and load information.
- ▶ Use the lugs / transport strapping points located on the cabinet roof.
- ▶ Secure the MKAS immediately against falling over.

3.4 Removing transport safety devices

- ▶ Check the system for transport safety devices and remove these.



NOTICE:

- ▶ Remove transport safety devices on control cabinet, filters, washing bottles and other parts before start-up.

3.5 Checking attachments and connections

- ▶ Check whether hose connections and screw connections have become loose during transport.

3.6 Inserting filter elements and bubbling frits (option)

- ▶ To prevent damage during transport, some components are disassembled and delivered in separate packing in the control cabinet (e.g. bubbling frits in washing bottles / humidifier containers or Raschig rings in special gas washers). Assemble or insert these before start-up.



NOTICE:

- Insert or fill filter elements, bubbling frits as well as Raschig rings before start-up.

3.7

Inserting the NOx converter cartridges (option)

- ▶ Check that the catalyzer cartridge is inserted in the NOx converter.
Converters built into MKAS analysis systems are normally delivered ready for operation with the catalyzer cartridge already fitted.

**NOTICE:**

- Observe the NOx converter Operating Instructions when inserting the catalyzer cartridge.
- Insert the catalyzer cartridge of the NOx converter before start-up.

**WARNING: Hot converter or hot catalyzer cartridge**

The surface of the converter or catalyzer cartridge can be hot.

- ▶ Take appropriate protective measures (e.g. wear gloves).
- ▶ Protect parts against unauthorized access.

3.8

Preparing for start-up of gas sampling probes

Observe the Operating Instructions / Assembly Instructions for the gas sampling probes when preparing for installation or start-up.

**WARNING: Overpressure in gas duct**

When opening the gas duct, gas flows out when overpressure exists.

- ▶ Take appropriate protective measures.

3.9

Gas lines

Gas connections for the standard MKAS analysis cabinet are located on the side or top of the control cabinet.

Refer to the view drawings or wiring diagram for the system-specific version of the MKAS analysis cabinet that can vary.

Fig. 6

Gas connections (example: Top view)

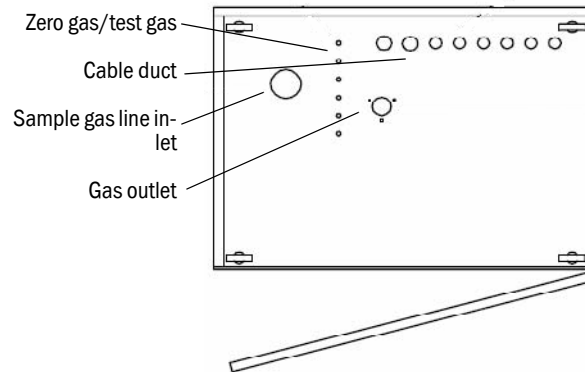

- The layout can vary specific to the system.

**WARNING: Noxious sample gas**

The gases can contain components harmful to health or irritating.

- ▶ Lead the measuring system gas outlets outdoors or into a suitable flue.
- ▶ Protect the sample gas outlet from frost.
- ▶ The sample gas must not penetrate the control cabinet.
- ▶ Observe information from the plant operator.

**WARNING: Caustic condensate**

Condensate created at the gas outlet and its deposits can be caustic.

- ▶ Channel condensate off safely.
- ▶ Observe suitable safety measures when disposing of condensate

**WARNING: Risk of explosion when explosive sample gas is used**

Risk of explosions when the gas path is not gas-tight.

- ▶ Do not deactivate the detonation flame arrester function integrated in the system when using the MKAS analysis system to measure explosive gases (sample gas supply line and outlet).

**NOTICE:**

- ▶ Make sure only the media for which the measuring system is designed are fed.
If necessary, have this checked by SICK Customer Service.
- ▶ The gas lines to the MKAS may only be laid by skilled persons who, based on their training and knowledge as well as knowledge of the relevant regulations, can assess the tasks given and recognize the dangers involved.
- ▶ Gas lines / sample gas lines may only be connected on the MKAS analysis system by SICK Customer Service or skilled personnel.
- ▶ Risk of damage to the MKAS and adjacent equipment if the sample gas is corrosive or could create corrosive liquids in combination with water (e.g. humidity).
- ▶ Measured values could possibly be erroneous when the gas path is leaky (dilution effect).
- ▶ Measured values could possibly be erroneous when a partial vacuum exists in the gas duct and when the gas path is leaky (dilution effect).
- ▶ No strong pressure fluctuations may occur at the sample gas outlet.
- ▶ Make sure sample gas can flow out »freely« (without pressure).
- ▶ No significant counterpressure may occur at the sample gas outlet.

3.10 Preparing the electrical installation



WARNING: Health risk by voltage

- ▶ Electrical connection of the MKAS may only be carried out by electricians who, based on their training and knowledge as well as knowledge of the relevant regulations, can assess the tasks given and recognize the dangers involved.
- ▶ For operation, the measuring system must always be grounded.
- ▶ Never disconnect or remove the protective conductors in the measuring system or in the supply line.

- ▶ Refer to the terminal diagram in the wiring diagram for a description of the terminal strips.

3.10.1 View of cable ducts on the control cabinet (symbolic)

The cable ducts on the MKAS analysis cabinet are located on the side or top of the control cabinet.

Refer to in the view drawings or wiring diagram for the system-specific version of the MKAS analysis cabinet that can vary.

Fig. 7 Cable ducts (example: Top view)

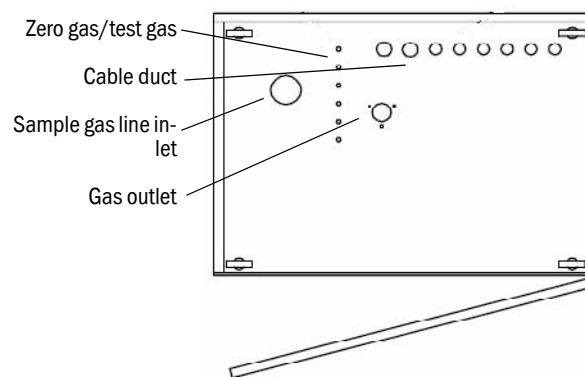

- The layout can vary specific to the system.

3.10.2 Preparation of mains supply

- Lead the mains supply to the analysis cabinet
- The wiring system to the mains supply voltage of the system must be installed and fused according to the relevant regulations.
- Provision of UPS (option)
- Before start-up, check the mains properties for nominal power/voltage/rating for system supply (auxiliary power) match the system-specific specifications of the MKAS analysis system.
- ▶ Refer to the system-specific wiring diagram or the System Documentation for details on the mains supply connection as well as specifications on nominal power/voltage/rating.

3.10.3 **External components and signal generators**

Carry out electrical and mechanical connection of project-related external components and signal generators and other project-specific peripherals to be integrated and then put these into operation.

- ▶ Refer to the system-specific wiring diagram and the corresponding Data Sheets or Operating Instructions of the respective components for details on the mains supply connection or connection to the MKAS analysis system as well as specifications on auxiliary power required (nominal power/voltage/rating).

3.11 **Connecting to the customer plant**

3.11.1 **Integration of the MKAS analysis system in the customer plant.**

- Lay all necessary connections according to the System Documentation:
 - Voltage supply
 - Signal lines
 - Integration of all external components

3.11.2 **Data evaluation (external interfaces)**

- Connection for data transfer / evaluation

MKAS

4 Start-up

Switching on
Start-up of system components

4.1 Persons authorized to carry out start-up



NOTICE:

- ▶ The MKAS may only be put into operation by skilled persons who, based on their device-specific training and knowledge, can assess the tasks given and recognize the dangers involved.

4.2 Start-up of washing bottles / humidifier containers (option)

- Insert the bubbling frits in the washing bottles / humidifier containers (option) (remove any transport safety devices still fitted (option))
- Fill the washing bottles / humidifier containers with solution or distilled water. Recommended filling level approx. 50%. The bubbling frit must be constantly immersed.
- Fill the gas washer with Raschig rings (option). (Remove any transport safety devices still fitted (option).)
- Due to application conditions (option), washing bottles / gas washers with the option of automatic media exchange are used. Refer to the wiring diagram of the MKAS analysis system for the corresponding specifications.

4.3 Adsorption pads (option)



WARNING: Noxious adsorbent

Depending on the sample gas or application, the adsorbent can be contaminated with noxious and / or highly flammable substances.

- ▶ Observe the relevant health and safety regulations.



NOTICE:

- ▶ Regeneration of the adsorbent is not allowed when it is contaminated with dangerous substances.
- ▶ Dispose of used adsorbent as hazardous waste according to the applicable disposal regulations.

- ▶ Fill the empty cartridge of the "FT-AP" filter fitting with the adsorbent planned for the application (e.g. silica gel / M&C "90F5110"). Observe the corresponding product information or the Data Sheet of the universal filter (FP / FP-AP) when filling or replacing adsorbent. The adsorption pad is used to adsorb water vapor in certain applications. The adsorbent becomes colorless with increasing absorption of moisture (silica gel "90F5110" with color indicator orange). Replace the adsorbent when it is completely colorless.

4.4 Before switching on ...



NOTICE:

Before start-up, the system must have been installed for at least 24 hours in its intended operating position at the installation location to achieve optimum operating conditions and prevent damage to system components.

- ▶ Check: Have all transport safety devices been removed (option)?
- ▶ Observe the ambient temperature for MKAS sample gas system or system components operation (→ „Technical Data“).
- ▶ Check: Is the inside of the MKAS analysis system dry and clean?
- ▶ Check: Are all filters and filter elements and inserts fitted and ready for operation?
- ▶ Check: Did hose connections become loose during transport?
- ▶ Check: Are all project-specific external components and signal generators to be integrated, e.g. sample gas probes and lines, temperature and pressure sensors or other external signal and measured value sensors, connected and ready for operation?
- ▶ Check that the catalyzer cartridge is inserted in the NOx converter.

4.5 Switching on the MKAS analysis system

- ▶ Switch the MKAS analysis system on using the main switch (“ON” position). Refer to the wiring diagram for the applicable name.
- ▶ Switch on the residual-current device (RCD). Refer to the system-specific wiring diagram for the relevant names (see System Documentation).
- ▶ Switch on all circuit breakers (MCB). Refer to the system-specific wiring diagram for the relevant names (see System Documentation).
- ▶ The MKAS analysis system is in the warming-up phase. Depending on the components to be measured and the measuring ranges, and the drift, the warming-up phase takes up to 24 hours. However, the typical case is that certain system components can cause a measurement at an earlier timepoint after, for example, reaching the required operating temperature even under consideration of possible drift and compliance with switch-on conditions (→ page 61, §9.4).
- ▶ Check external AC-operated components as well as components (optional) supplied by the MKAS measuring system, for example purge air units, fans, compressors, for the correct direction of rotation / rotating fields.

4.6 Start-up for the sample gas cooler (option)

- ▶ For start-up, observe the sample gas cooler Operating Instructions.
- ▶ Wait for the cooler warm-up phase to end (duration: approx. 30 minutes). A green LED indicates when the operating temperature has been reached.
- ▶ Switch on the sample gas cooler at the front of the device.

4.7

Start-up for the analyzer (SIDOR; S710)

- ▶ For start-up, observe the analyzer Operating Instructions.
- ▶ Wait for the analyzer start-up phase to end (duration: approx. 15 minutes).
- ▶ Switch on the analyzer using the mains switch at the rear of the device.
- ▶ Query the device status via the analyzer main menu.
Proceed according to the Operating Instructions.
- ▶ Set or control the required gas throughput according to the analyzer Operating Instructions.



This is, at the same time, start-up monitoring of the complete analysis system to determine any possible malfunctions.

Refer to the details on clearing malfunctions in this System description as well as in the analyzer Operating Instructions.

4.8

Start-up for the NO_x converter (option)

- ▶ For start-up, observe the NO_x converter Operating Instructions.
- ▶ Check that the cartridge has been inserted.
- ▶ Wait for the converter start-up phase to end (duration: approx. 15 to 30 minutes).
- ▶ The converter is ready for operation after the preset operating temperature is reached.

**WARNING: Hot converter or hot catalyzer cartridge**

The surface of the converter or catalyzer cartridge can be hot.

- ▶ Take appropriate protective measures (e.g. wear gloves).
- ▶ Protect parts against unauthorized access.

4.9

Start-up for the DAU (MEAC2000 connection) (option)

- ▶ Switch on the DAU using the mains switch at the rear of the device.

Refer to the "MEAC2000" Operating Instructions and the specific project documents as well as the wiring diagram for technical details.

Start-up for the cabinet climate control (option)



NOTICE:

- ▶ Avoid frequent, short starts of the control cabinet cooling unit or opening the control cabinet door frequently for short periods.
- ▶ Observe the minimum switch-off times when switching the control cabinet cooling unit or the complete MKAS analysis system on or off.
Non-observance can damage the control cabinet cooling unit.
- ▶ Refer to the specific Operating Instructions of the control cabinet climate control for the recommended minimum switch-off time.

- ▶ Observe the respective Operating Instructions and Data Sheets in the System Documentation when starting-up the climate control components.
- ▶ Adapt the settings for operating parameters / temperatures to local conditions. Otherwise components of the MKAS analysis system could fail or be damaged.
- ▶ Wait for a certain time after installation or initial start-up to ensure optimum lubrication and cooling of the control cabinet cooling unit. Refer to the specific Operating Instructions of the control cabinet cooling unit for details on this waiting time.

The corresponding cabinet climate control components are fitted on the MKAS analysis system depending on the planned usage location (local conditions). The following will be used, for example:

- Control cabinet fan (option)
- Control cabinet cooling unit (option)
- Control cabinet heating (option)
- ▶ Refer to the relevant Operating Instructions for details on start-up and operation of the individual components or the wait time for the control cabinet cooling unit.
- ▶ The climate control components are set at the factory to the following operating parameters / temperatures:
 - Control cabinet fan / cabinet thermostat: 25 °C
 - Control cabinet cooling unit: 25 °C
 - Heating: Approx. 15 °C to 20 °C
- ▶ These settings must be adapted to local conditions. Internal system components of the MKAS analysis system can be damaged when operating / ambient temperatures are too low or high.

Information on operation / function of the control cabinet cooling unit

An additional door limit switch is normally fitted to avoid higher condensate levels when the control cabinet door is open.

Switching the cooling function off and on is delayed automatically to avoid a possible cyclic operation when the door is opened and closed. Refer to the Operating instructions of the control cabinet cooling unit for duration and further details on the switching delay.

Whenever possible, avoid frequent, short starts of the control cabinet cooling unit or opening the control cabinet door frequently for short periods.

4.11

Start-up for the gas warning system (option)

System-specific gas warning systems are used (gas monitor, gas measurement computer) as well as the associated visual and acoustic signal reporting devices depending on the measuring medium and the type of application.

Limit and threshold values (alarm thresholds) are preset at the factory. These must be adapted onsite by the operator to local conditions and safety regulations during start-up.

- ▶ Observe the relevant information in the Operating Instructions and the Data Sheets in the System Documentation.
- ▶ The operator must check the limit values or threshold values (alarm thresholds) set at the factory and adapt these onsite to local conditions.

**WARNING: Hazards through erroneous settings**

The settings must meet the relevant regulations and safety regulations as well as laws on monitoring toxic gases and / or LEL monitoring.

4.12

Start-up for the heated gas sampling probe

- ▶ The sample gas probe is a system / project-specific external functional unit (option). Observe the Operating Instructions / Assembly Instructions for the gas sampling probe during start-up.
- ▶ Wait for the heating up time for the gas sampling probe to end (duration: Approx. 2 hours).
- ▶ Check the nominal value setting on the built-in thermostat or on the external controller (option regulated heating) (refer to the wiring diagram for the nominal values).
- ▶ Make sure the built-in ball valve is closed on gas sampling probes with ball valve (option).

**WARNING: Hot probe and hot filter**

The surfaces of the probe or filter can be hot.

- ▶ Take appropriate protective measures (e.g. wear gloves).
- ▶ Protect parts against unauthorized access.

**WARNING: Hazard through overpressure in the gas duct**

When opening the gas duct, gas flows out when overpressure exists.

- ▶ When necessary: Take suitable protective measures.

**WARNING: Risk of explosions when explosive sample gas is used**

Risk of explosions when the gas path is not gas-tight.

**WARNING: Hazard through noxious sample gases**

The sample gases can contain components harmful to health or irritating.

- ▶ When necessary: Take suitable protective measures.

4.13

Restarting after longer shutdown

Restarting after a longer shutdown (several weeks) requires cooperation between Service technicians and the planning engineers responsible for the plant environment.

- ▶ Please contact SICK Customer Service to clarify the individual precautionary measures required for a restart after a longer shutdown (several weeks).
- ▶ Ensure the following as preparatory work for clarification:
Check that the system and system components are in a ready for operation state according to the instructions on start-up (→ page 29, §4) as well as maintenance (→ page 47, §8) as described in these MKAS Operating Instructions and the Operating Instructions for the system components.

System component(s) (What to check)	Technical Checks
Lines / hoses	Free of condensate, blocked, soiled, cracks, porous, brittle, tight and correct seat.
Filter	Free of condensate, not soiled, ready for operation. Note: Replace the filter elements / inserts / wool when discolored.
Washing bottles, gas washers, humidifier containers	Ready for operation (fill when necessary).
Adsorption pads	Ready for operation (fill / replace when necessary).
Sample gas pump	Ready for operation.
Water trap	Free from condensate (replace the water trap when necessary). Note: If condensate is present, the water traps block and must be replaced.
Analyzer	Ready for operation.
NOx converter (option)	Ready for operation (including cartridge).
Gas cooler	Ready for operation.
Span gases	Use-by date, remaining reserves, pressures.
Cabinet climate control	Ready for operation.
Gas monitor / Gas measurement computer	Ready for operation.
Detonation flame arrester	Ready for operation (check for contamination).
Condensate collection container (with level switch)	Ready for operation (empty when necessary).
Sample gas outlet, sample gas recirculation	Free from blockages.
Sampling probe	Ready for operation.
External components and signal generators	Ready for operation.

- ▶ In addition to this list, also observe the information and conditions for particular system components in Sections “Start-up” (→ page 29, §4) and “Maintenance” (→ page 47, §8) in these MKAS Operating Instructions.
- ▶ Refer to the Operating Instructions for the individual system components for further details and information.

MKAS

5 Operation

Operation of the system components

5.1 **Operation of system components**

The MKAS analysis system is a user-friendly and low-maintenance measuring system that functions with self-monitoring. Refer to the Operating Instructions of the individual system components as described in these Operating Instructions for operating details. (→ page 9, §1.3)

5.2 **Layout and functions of system components**

Refer to the wiring diagram for the layout and function of the individual system components in the MKAS analysis system.

5.3 **System Parameters**

Refer to the System Documentation as well as the wiring diagram for details concerning setting the system parameters of the MKAS analysis system.

MKAS

6 Adjusting

Adjustment

6.1 When is adjustment necessary?

The MKAS measuring system or the analyzer should be adjusted:

- After start-up
- In regular intervals during operation (about weekly to monthly is recommended).
- For emission measurement required by law according to the Certification or legal specifications.
- The specific adjustment cycles depend on the application and are not the responsibility of SICK AG.

6.2 Basic variants of the adjustment procedure

Two principle span gas feeding options exist:

- External test gas feed directly to the gas sampling probe (option)
- Internal test gas feed to the sample gas cooler in the MKAS analysis system
- ▶ Refer to the wiring diagram in the project documentation of the MKAS analysis system for the system-specific variants.

Adjustment can be performed either with automatic or manual control:

- Automatic calibration
- Manual calibration with automatic feeding of test gases
- Manual calibration with manual feeding of test gases
- ▶ Depending on the analyzer, adjustment can be performed with external span gases, with internal calibration cuvette and / or ambient air.
- ▶ Refer to the Operating Instructions of the corresponding analyzer for further details describing the adjustment variants.

6.3 Performing the adjustment procedure

- ▶ Refer to the Operating Instructions of the corresponding analyzer and the wiring diagram of the MKAS analysis system for further details on performing adjustment resp. the description of the respective analyzer adjustment.

General information on adjustment

- Span gases must be connected or fed in the specified concentrations as well as with the specified maximum pressures.
- Consider the test gas delay time as well as the adjustment measuring interval specific to the application (e.g. consider the line length).

Information on automatic adjustment:

- ▶ Adapt the factory settings made for the start time and the time interval for automatic adjustment starts to the system/project-specific conditions.
- ▶ Adapt the factory settings for test gas delay time and adjustment measuring interval to the application-specific conditions.

6.4 Adjusting (or possible calibration) external components and signal generators

External components and signal generators connected to the MKAS measuring system or fed by the MKAS measuring system must be adjusted or calibrated according to the individual component characteristics and applications, independent from the MKAS measuring system.

MKAS

7 Shutdown

Standby operation
Switch-off procedure / switching off
Shutdown
Storage
Disposal

7.1 General information

**NOTICE:**

- ▶ Comply with the safety information, applicable health and safety measures and the instruction sequence during shutdown.

7.2 Standby operation (Maintenance mode)

The MKAS analysis system can be set to Standby operation (Maintenance mode) for a short time to allow, for example, maintenance work and / or to avoid long restart times after a targeted measurement operation interruption.

This Standby state is achieved by putting the sample gas pump out of operation to stop sample gas feed. To do this, the »Maintenance« status output must be activated per menu function on the analyzer.

Refer to the Operating Instructions of the analyzer for details on operation and the relevant menu functions.

Activating the »Maintenance« menu function with the analyzer automatically switches off the sample gas pump and a maintenance signal informs a possible external location that the MKAS analysis system is not in regular operation and pending measurement signals are therefore implausible.



An optional maintenance switch is fitted on the MKAS analysis system depending on the system. If operating mode »Maintenance« is activated using this maintenance switch, the sample gas pump function is not put out of operation and only the maintenance signal is sent to a possible external location.

7.3 Switch-off procedure / switching off

7.3.1 Safety measure: Secure connected locations

- 1 Shutting down the MKAS analysis system / gas analyzer can affect external locations. Inform external locations as required.
- 2 Make sure automatic contingency measures are not triggered when shutting down. It may be necessary to take into consideration with which switching logic the switching outputs of the MKAS analysis system / gas analyzer function.
 - ▶ Observe the Operating Instructions for the gas analyzer.
- 3 If a data processing system is connected, it may be required to manually indicate a planned shutdown, so that the system will not interpret the shutdown as an MKAS analysis system malfunction.

7.3.2

Safety measure: Completely remove the sample gas**WARNING: Hazard through noxious sample gases**

If the MKAS analysis system was used to measure toxic or dangerous gases:

- ▶ When necessary: Take suitable protective measures.
- ▶ Purge the measuring system sufficiently long with a neutral gas (e.g. with nitrogen)

**NOTICE:**

- ▶ Consider the maximum allowable (sample) gas pressure of the analyzer when purging with a neutral gas.
- ▶ Refer to the Operating Instructions or the Data Sheet of the analyzer for the applicable maximum sample gas pressure.

7.3.2.1

When measuring toxic, dangerous or wet gases

If the MKAS analysis system was used to measure toxic, dangerous or wet gases, gas paths as well as components carrying sample gas must be purged thoroughly with a neutral gas before shutting down.

- 1 Purge all the gas paths of the MKAS analysis system, including external sample gas lines, for several minutes with a »dry« neutral gas - e.g. with nitrogen (techn.).
 - ▶ Consider the maximum allowable sample gas pressure of the analyzer when purging with a neutral gas. Refer to the Operating Instructions or the Data Sheet of the analyzer for the applicable maximum sample gas pressure.
 - Purging with ambient air could also be considered depending on the application and ambient conditions.
In this case, it suffices when the system suctions in ambient air for several minutes on the sample gas probe side.
(It may be necessary to pull the sample gas probe out of the duct here.--> Attention! Application conditions and safety information must be observed.)
- 2 Now stop sample gas feed, close off all gas connections of the MKAS analysis system, or close the relevant valves in the purged gas path.
Sample gas feed (resp. sample gas suctioning in) can be interrupted by switching the sample gas pumps / analyzers off or via a corresponding manual analyzer menu function. Refer to the Operating Instructions of the relevant analyzer for details on operation and menu functions.



It is recommended to activate the »Maintenance« status output per menu function on the analyzer. This switches the sample gas pump off and sends a maintenance signal to a possible external location to signal that the MKAS analysis system is no longer in regular operation.

7.3.2.2

When measuring harmless gases**WARNING:**

In case of doubt please contact the plant operator or SICK Customer Service to clarify or classify the sample gas as a harmless medium.

- 1 Stop sample gas feed to the MKAS analysis system by switching off the sample gas pumps / analyzers or via a corresponding manual analyzer menu function as well as by closing off any shutoff fittings installed.
 - ▶ Refer to the Operating Instructions of the relevant analyzer for details on operation.



It is recommended to activate the »Maintenance« status output per menu function on the analyzer. This switches the sample gas pump off and sends a maintenance signal to a possible external location to signal that the MKAS analysis system is no longer in regular operation and pending measurement signals are therefore implausible.

- 2 Separate the MKAS analysis system from the external sample gas paths so that no sample gas and test gas can flow into the MKAS analysis system. (E.g. with overpressure in the measuring channel.)
- 3 Now close off all gas connections, lines and valves on the MKAS analysis system.

7.3.3

Switch off

- ▶ Switch the MKAS analysis system off using the main switch ("OFF" position). Refer to the wiring diagram for the corresponding name and location / position of the main switch.

**NOTICE:**

With control cabinet climate control devices (option):

- ▶ Observe the minimum switch-off times for the control cabinet cooling unit when switching the MKAS analysis system on or off. Non-observance can damage the control cabinet cooling unit.
- ▶ Refer to the specific Operating Instructions of the control cabinet cooling unit for the recommended minimum switch-off time.

7.4

Shutdown

- ▶ Disconnect the MKAS measuring system completely from the mains.
- ▶ Separate the sample gas line from the probe and cabinet.



WARNING: Hazard through noxious sample gases

If the MKAS analysis system was used to measure toxic or dangerous gases:

- ▶ When necessary: Take suitable protective measures.
- ▶ Purge the measuring system sufficiently long with a neutral gas (e.g. with nitrogen)

- ▶ Dispose of the condensate.



WARNING: Caustic condensate

- ▶ Observe suitable safety measures when disposing of condensate.
- ▶ Dispose of condensate according to local regulations.

- ▶ Empty and dispose of adsorbent.



WARNING: Noxious adsorbent

Depending on the sample gas or application, the adsorbent can be contaminated with noxious and / or highly flammable substances.

- ▶ Observe the relevant health and safety regulations.
- ▶ Regeneration of the adsorbent is not allowed when it is contaminated with dangerous substances.
- ▶ Dispose of used adsorbent as hazardous waste according to the applicable disposal regulations.

- ▶ Empty washing bottles / humidifier containers (option).
- ▶ Close off the gas inlet / outlet on the analyzer.
- ▶ Close off the end of the sample gas line on the probe side.
- ▶ Dismantle the sample gas probes and close off the connections with blind flanges.
- ▶ Disconnect or close off any other optional connections (e.g. instrument air, water connections, connections for condensate outlet).

7.5

Storage

Storage conditions:

- Indoors.
- Ambient temperature: -20 - + 55 °C.
- Relative humidity max. 80%, without condensation.
- Recommendation: Store the MKAS as dry as possible.



To prevent condensate occurring, purge the internal sample gas path thoroughly with a »dry« neutral gas before shutting down.

7.6

Disposal

Observe the relevant local conditions for the disposal of industrial waste.



The liquid in the dismantled storage container is acidic and contains inorganic or organic substances that are toxic or harmful to the environment. This waste must be disposed off according to the legal regulations and as hazardous waste when necessary.

The following subassemblies could contain substances that have to be disposed of separately:

- *Electronics*: Condensers, rechargeable batteries, batteries.
- *Display*: Liquid of LC display.
- *Sample gas filters*: Sample gas filters could be contaminated by pollutants.
- *Adsorption pads*: Adsorption pads can be contaminated with pollutants.
- *Sample gas paths*: Toxic materials in the sample gas could have been absorbed or trapped in »soft« gas path materials (e.g. hoses, sealing rings). Please check whether such effects have to be considered during disposal.
- *Analyzer Modules*
 - Observe the information on disposal in the Operating Instructions of the relevant analyzer.
- *Cabinet cooling unit (option)*:
 - Correct disposal of refrigerants of the cabinet climate unit.
 - Observe the information on disposal in the Operating Instructions of the relevant cabinet cooling unit.

MKAS

8 Maintenance

Maintenance, information
Maintenance signal
Maintenance recommendation
Spare and wearing parts

Important maintenance information



WARNING:

- Whenever possible, only replace components with the equipment switched off.
(Maintenance work could also be carried out conditionally in “Maintenance mode” under consideration of all safety regulations and information).
- If you have to open the device for adjustment or maintenance work, repair or replacement of parts, disconnect it first from all voltage sources.
- If the open device must be live for adjustment or maintenance, this work has to be performed by skilled persons who are familiar with potential hazards.
- Never interrupt the protective conductor connections inside or outside the device. The interruption can cause the device to become dangerous.
- If you have reason to suspect that safe operation of the device is no longer possible, put the device out of operation and secure it against unauthorized start-up.
- No components may be removed, added or changed on the device unless described and specified in the official manufacturer information. Otherwise:
 - Any warranty by the manufacturer becomes void
 - The approval could become void
- If you feed combustible or explosive sample gas through the analyzer: There is risk of explosions when the gas path is leaky or when the closed gas paths or lines are opened.
- Do not put the detonation flame arrester function integrated in the system in the sample gas supply line as well as the sample gas outlet out of operation when using the MKAS analysis system to measure explosive gases.
- Depending on the measuring medium, toxic deposits could be contained in the feeders with media contact.
- Acidic solutions (condensate) can occur.
- Attention: Depending on the sample gas or application, the adsorbent can be contaminated with noxious and / or highly flammable substances.
- Surfaces of system components can be hot.
(E.g.: converter enclosure, converter cartridge, gas sampling probe, sample gas line, and others.)



- The liquid in the dismantled storage container is acidic and contains inorganic or organic substances that are toxic or harmful to the environment.
- Used adsorbent is hazardous waste.
- ▶ This waste must be disposed off according the legal regulations and as hazardous waste when necessary.



Refer to the Operating Instructions of the respective system components for further details on maintenance and warning / safety information.

8.2 **Maintenance signal (Maintenance mode)**

The »Maintenance« status output can be activated manually to signal to external locations that the MKAS analysis system is not longer in regular operation, for example because maintenance work is being carried out.

Activation is done per analyzer menu function or separate maintenance switch depending on the project planning and version of the MKAS analysis system.

- ▶ Refer to the Operating Instructions of the relevant analyzer or the wiring diagram for version and details.

Activating »Maintenance« mode per analyzer menu function automatically switches off the sample gas pump and a maintenance signal informs a possible external location that pending measurement signals are therefore implausible.

If operating mode »Maintenance« is activated per optional maintenance switch (system-specific equipment), the sample gas pump function is not put out of operation and only the maintenance signal is sent to a possible external location.

- ▶ Remember to switch the maintenance signal off again when it is no longer needed.

8.3 **Visual inspection / function control**

Check the operating state of the devices by visual inspection.

- ▶ It is recommended to carry out this visual check once a week.
- ▶ For the complete analysis system
Regular checks of screw connections, hose connections, gas lines and other connections to the MKAS, the probe and further system components.
- ▶ Check enclosure and condensate pump for possible damage by acids.

8.4 Description of maintenance work

8.4.1 Maintenance recommendations / maintenance intervals

- Maintenance intervals depend on the application.
- In principle, the maintenance recommendations in the respective Operating Instructions of the system components are applicable. All the recommendations depend on the process and are not within SICK's area of responsibility.
 - Refer also to the Operating Instructions of the respective system components.
- SICK recommends the following checks. (Based on average operation.)

System component	Recommended inspection / Description of maintenance	Recommended maintenance intervals		
		Weekly	Monthly	Yearly
Gas sampling probe (option)	Check filters and seals. Replace filters regularly depending on wear. Remark: Observe the Operating Instructions of the gas sampling probe.		X	
Sample gas line (option)	Check heating function. Clean regularly. Remark: Observe respective Operating Instructions or Assembly Guidelines on fitting heating hoses.		X	
Filter (option)	Check filter condition / degree of contamination. (Filter wear can vary depending on the application.) Check for condensate in filter housing bottom. Drain off condensate when necessary. Remark: Observe relevant Operating Instructions / Data Sheets.	X		
Corrosion inhibitor filter (option) (Brass wool filter)	Check filter condition. (Filter wear can vary depending on the application.) (Replacement criterion depending on the application: 2/3 colored dark / or strong wool degradation) Attention: When replacing brass or glass wool, make sure no particles can penetrate the control cabinet.	X		
Glass wool filter (option)				
Gas washer (option) Washing bottles (option) Humidifier container (option) (Water pads)	Check function. Check liquid reserves (solution resp. distilled water) in washing bottles / humidifier containers and top up as necessary. (Recommend filling quantity approx. 50% of container volume.) Check function of gas washer with automatic media replacement (ensure feed/drainage). Check for contamination / blockage. Clean bottles and bubbling frits resp. Raschig rings regularly. Note: Bubbling frits / Raschig rings - Rings are fragile.	X		
Sample gas pump (option)	Check pump function. Remark: Observe relevant Operating Instructions.		X	
Water trap	Replace water trap at least once a year. Note: Water trap blocks when condensate occurs and must be replaced. In this case, the system reports "System error" because the gas flow is interrupted.			X
Filter fan of cabinet vent (option)	Check filter fan function. Clean heavily soiled filter pads and replace as necessary. Set filter pad replacement interval individually depending on dust volume and operating time. Attention: Replace filters in good time. Dirty filter pads lead to temperature increases in control cabinets. Filter pads can be cleaned by flushing or blowing out. Remark: Observe Operating Instructions of filter fan.		X	
Cabinet thermostat (option)	Check function in connection with the filter fan.		X	
Condensate container (with level switch)	Check container condition. Empty when necessary. (Warning message) Note: Sample gas condensate is hazardous waste. Observe regulations on condensate disposal according to the Water Resources Law (WHG). Attention: The liquid contains acid. Observe relevant health and safety regulations.		X	
System components	Recommended inspection / Description of maintenance			

Adsorption pads (universal filter) (option)	<p>The adsorption pad is used to adsorb water vapor in certain applications. The adsorbent becomes colorless as it absorbs more and more moisture (e.g. silica gel / M&C "90F5110" with color indicator orange). Replace the adsorbent when it is completely colorless. The state of the adsorbent can be seen from the outside without having to unscrew the filter.</p> <p>Remark: Observe the relevant product information resp. the Data Sheet of the universal filter ("FT-AP" Filter fitting) when filling the filter cartridge with the adsorbent planned for the application.</p> <p>Attention: Depending on the sample gas resp. application, the adsorbent can be contaminated with noxious and / or highly flammable substances.</p> <p>Dispose of used adsorbent as hazardous waste according to the applicable disposal regulations.</p> <p>Attention: Observe the applicable health and safety regulations.</p> <p>Note: Regeneration of the adsorbent is not allowed when it is contaminated with dangerous substances.</p>
Sample gas cooler (including condensate pump)	<p>Check enclosure and condensate pump for any possible damage.</p> <p>Replace the Teflon filter cartridge, when fitted as an option, regularly depending on wear and contamination.</p> <p>Regulate refrigerant condensers regularly depending on contamination.</p> <p>Replace condensate pump hoses regularly depending on wear but at least once a year. It is recommended to replace hoses every 3 months as precautionary measure.</p> <p>Attention: The condensate can be acidic.</p> <p>Check screw connections / connections.</p> <p>Remark: Observe Operating Instructions of sample gas cooler</p>
Condensate pump (option)	<p>Check enclosure and condensate pump for any possible damage.</p> <p>Replace condensate pump hoses regularly depending on wear but at least once a year. It is recommended to replace hoses every 3 months as precautionary measure.</p> <p>Attention: The condensate can be acidic.</p> <p>Check screw connections / connections.</p> <p>(Remark: Observe Operating Instructions for condensate pump.)</p>
Analyzer	Refer to Operating Instructions of relevant analyzer.
NOx converter (option)	<p>Note: Make sure the correct cartridge type is used when replacing / exchanging catalyzer cartridges (differing temperature ranges).</p> <p>Refer to Operating Instructions of converter for details on exchanging catalyzer cartridges.</p> <p>Warning: Very hot catalyzer cartridge. Risk of burns when exchanging.</p>
Gas monitor / Gas measurement computer (Option) (Gas warning system)	<p>Have it tested in appropriate intervals with test gas by skilled Service personnel.</p> <p>Remark: Observe Operating Instructions of gas monitor.</p> <p>Attention: The operator must check the limit values resp. threshold values (alarm thresholds) set at the factory and adapt onsite to local conditions. The settings must observe the relevant regulations and safety regulations as well as laws on monitoring toxic gases and / or LEL monitoring.</p> <p>Recommendation: Conclude a maintenance contract with the Service department of the device manufacturer.</p> <p>Note: In case of an alarm, sample and test gas feed are interrupted and a visual as well as acoustic warning message triggered.</p>
Detonation flame arrester (option)	<p>Inspect detonation flame arresters regularly for contamination and clean as necessary.</p> <p>Note: Intervals depend on media flowing through. A minimum inspection interval of one year is generally recommended. The operator must determine maintenance intervals. If the no operating experience is available, the operator must initially check the equipment with regularly inspections during the start-up phase to determine when contamination occurs and then define the maintenance intervals.</p> <p>Attention: Observe laws and protective regulations applicable at the installation location. Operator and responsible supervisors are responsible for compliance with these regulations. Maintenance work must be carried out by qualified skilled persons.</p> <p>Remark: Observe maintenance information in Operating Instructions.</p>
Lines / hoses	<p>Check for possible blockages, spoiling, cracks.</p> <p>Check for possible porous or brittle condition. Check for tight, correct seat.</p> <p>Clean or replace lines / hoses as necessary.</p>
Control cabinet cooler (option)	Refer to Operating Instructions of respective system components.
Span gases (option)	<p>Check condition and availability of span gases regularly (e.g.: Feed pressure from central gas supply, remaining reserves in pressure cylinders, use-by date).</p> <p>(Option: Monitor cylinder pressure with contact pressure gauge.)</p>

8.5 **Cleaning information**

- ▶ Use a soft cloth to clean the cabinet on the outside and inside.
- ▶ Do not use any mechanically or chemically aggressive cleaning agents.
- ▶ Do not allow any liquids to penetrate the control cabinet or enclosures of system components.

8.6 **Recommended spare parts (SP) / wearing parts (WP)**8.6.1 **SP/WP for internal components**

- Wearing and spare parts depend on the analyzer and application.
- Service life of wearing parts depends on the application.
- ▶ Store parts in a dry, ventilated area protected against dust.
- ▶ Avoid long storage times.

Sample gas filter / Filter SICK					
Description	Part No.	Fitted in	WP	SP	Requirement per x year(s)
Filter-diaphragm made of glass fiber 55 mm diameter Sales unit=25 pcs.	5 312 005	Front fitted filter FI56NK3(2028590) Ext. filter	X		1 pc./ 1 y.
Safety filter FI64 glass, 2 µm, for hose diameter=4 mm	2 027 973	S700 / SIDOR		X	1 pc./ 2 y.
Brass wool, approx. 12 g	2 028 844	Corrosion inhibitor filter (2028305)	X		2 pcs./ 1 y.
Coupling GL18 - DN4/6 - PVDF	5 312 119	Corrosion inhibitor filter (2028305)		X	2 pcs./ 2 y.
Filter tube DURAN L=200 mm D=18 mm 2xGL18	4 039 113	Corrosion inhibitor filter (2028305)		X	1 pc./ 2 y.
Corrosion inhibitor filter, complete - incl. filling (brass wool) - incl. 2 connections DN4/6 PVDF (l=230 mm, D =16, glass)	2 028 305			X	1 pc./ 2 y.
Filterwool, glass No. 703 11 µm Sales unit=500 g	5 311 940	Glass wool filter	X		1 pc./ 1 y.
Coupling GL32 - DN4/6 - PVDF	5 312 284	Glass wool filter		X	2 pcs./ 2 y.
Filter tube DURAN L=250 mm D=40 mm 2xGL32	4 039 232	Glass wool filter		X	1 pc./ 2 y.
Water trap WT20.5K	5 313 317	Water trap		X	1 pc./ 2 y.
Filter element (front panel)	5 317 730	(2 028 590) FI56NK3 Front fitted filter Diaphragm fine filter (view filter)	X		1 pc./ 1 y.

Sample gas filter / Filter M&C					
Description	Part No.	Fitted in	WP	SP	Requirement per x year(s)
Filter element F-0,1GF50 (glass fiber) 0.1 µm	2 038 474	Front fitted filter FPF-0,1GF (5311705)	X		1 pc./ 1 y.
Filter element F-2T (PTFE) 2 µm	5 312 341	Universal filter FP, FT, FS	X		1 pc./ 1 y.
Filter glass F-120G	5 312 766	Universal filter FP, FT, FS		X	1 pc./ 2 y.
Filter glass F-240G	5 312 707	Universal filter FP, FT, FS		X	1 pc./ 2 y.
Spare Viton ring 26	5 312 775	Universal filter FP, FT, FS	X		1 pc./ 1 y.
Filter element for filter CLF-5	5312349/ 5 311 437	Aerosolfilter CLF-5 (5311101)	X		1 pc./ 1 y.
Spare parts set I for filter CLF-5/W (filter frit, diaphragm filter, flat ring disc, O-ring)	5 312 359	Aerosolfilter CLF-5/W (5311436)	X		1 pc./ 1 y.
Spare parts set II for filter CLF-5/w (diaphragm filter, flat ring disc)	5 312 360	Aerosolfilter CLF-5/W (5311436)	X		1 pc./ 1 y.
Adsorption pad / Filter FT-AP 03F5200 (M&C)	5 322 648	----		X	1 pc./ 2 y.
Adsorption material For adsorption pad Dry beads with moisture indicator. (silica gel) Color: orange, quantity: 1000 ml	5 603 168	Adsorption pad FT-AP 03F5200 (M&C)	X		As required

Sample gas filter / Filter Bühler					
Description	Part No.	Fitted in	WP	SP	Requirement per x year(s)
Filterelement S2(glassfiber)2µm Sales unit=5 pcs.	5 312 243	Fine filter AGF-PV-30-S2 (5312425)	X		1 pc./ 1 y.
Filterelement F2L(PTFE)2µm Sales unit=1 pc.	5 317 771	Fein filter AGF-PV-30-F2L (0730459)	X		1 pc./ 1 y.
Filterelement F25(PTFE)25µm Sales unit=5 pcs.	5 311 943	Fine filter AGF-PV-30-F25 (5312424)	X		1 pc./ 1 y.
Filterelement F25L(PTFE)25µm Sales unit=1 pc.	0 026 797	Fine filter AGF-PV-30-F25L (0026796)	X		1 pc./ 1 y.
Filterelement F2(PTFE)2µm Sales unit=5 pcs.	5 322 649	Fine filter AGF-T-30-F2 (5312703)	X		1 pc./ 1 y.
Filterelement DRG25VA-V(1.4301)25µm Sales unit=1 pc.	5 312 687	Fine filter AGF-VA-23V (5312686)	X		1 pc./ 1 y.
Filterelement 12-57-C(borsilicatefiber) Sales unit=1 pc.	5 312 319	Coalescence filter K-AGF-PV-30-A (5317088)	X		1 pc./ 1 y.

Filter pad for cabinet fan					
Description	Part No.	Fitted in	WP	SP	Requirement per x year(s)
Spare filter pad for outlet filter and filter fan W 173 x H 173 x D 17	5 306 678	Outlet filter SK3323.xxx (5 315 501)	X		As required
Spare filter pad for outlet filter and filter fan W 289 x H 289 x D 17	5 308 584	Outlet filter SK3326.xxx (5 314 520)	X		As required

Washing bottles / humidifier containers					
Description	Part No.	Fitted in	WP	SP	Requirement per x year(s)
Humidifier container, complete	5 320 642			X	As required
FP-BF (G1/4) (03F5700)					
Washing bottle, complete	5 311 644			X	As required
FP-W (G1/4) (03F5300)					
Washing bottle, complete	5 314 373			X	As required
FP-W (GL18) (03F5500)					
Gas washer, complete	2 038 449			X	As required
Gas washer bottle DURAN D=50,L=280.3xGL14 incl. Raschig rings approx. 5 x 5 mm, approx. 120 ml incl. screw cap and O-ring ID=48, S=4					

Sample gas pump, Bühler					
Description	Part No.	Fitted in	WP	SP	Requirement per x year(s)
Bellow, complete with threaded pin, for sample gas pump P2.3SP, PTFE (4200059)	5 312 043	Sample gas pump P2.3SP / -V (6032166 / 6026333)		X	1 pc./ 2 y.
Set of inlet/outlet valves for sample gas pump P2.x, max. 80°C (4201002)	5 311 455	Sample gas pump P2.3SP / -V (6032166 / 6026333)		X	1 pc./ 2 y.
Set of inlet/outlet valves for sample gas pump P2.x, max. 140°C (4202002) 0 743 493 ET	5 312 793	Sample gas pump P2.3SP / -V (6032166 / 6026333)		X	1 pc./ 2 y.
Spare parts set: Tappet; excenter, screw and ball bearing (4200075)	2 027 980	Sample gas pump P2.3SP (6032166)		X	1 pc./ 2 y.
Sample gas pump, complete, Bühler P2.3SP	6 032 166			X	1 pc./ 3 y.
Sample gas pump, complete, Bühler P2.3SP-V	6 026 333			X	1 pc./ 3 y.

Sample gas pump KNF					
Description	Part No.	Fitted in	WP	SP	Requirement per x year(s)
Spare parts set for pump N86KT.18 comprising: 1 pc. structured diaphragm 2 pcs. valve plate, 2 pcs. seal	5 312 317	Sample gas pump	X		1 pc./ 1 y.
Sample gas pump, complete, N86 KT.19 231 VAC, in enclosure, flow rate approx. 250 l/h	7 027 252	Sample gas pump		X	1 pc./ 3 y.

NOx converter M&C					
Description	Part No.	Fitted in	WP	SP	Requirement per x year(s)
Heater CG-2 (95A9057), 230V/50/60Hz	6 027 894	NOx converter CG2		X	1 pc./ 2 y.
Converter cartridge CG-2-C (95A9003) carbon filling, T=350°C with spare O-ring-set	5 320 289	NOx converter CG	X		1 pc./ 1 y.
Converter cartridge CG-2-SS (95A9004) stainless steel wool filling, T=660°C, with spare O-ring-set	5 315 396	NOx converter CG	X		1 pc./ 1 y.

Analyzer S700 / SIDOR					
Description	Part No.	Fitted in	WP	SP	Requirement per x year(s)
Spare parts set, mains plug combination 1 device plug element 1 protective cover, 1 drawer 2 G fuses 5x20, M 4.0A 2 G fuses 5x20, M 2.0A	2 028 437	S700 / SIDOR		X	1 pc./ 2 y.
Safety filter Fl64 glass, 2 µm, for hose diameter=4 mm	2 027 973	S700 / SIDOR		X	1 pc./ 2 y.

Spare parts set, pump parts TYP123 diaphragm set EPDM/ozone resistant with 4 rings to hang up	2 028 438	S700 / SIDOR		X	1 pc./ 2 y.
---	-----------	--------------	--	----------	-------------

Sample gas cooler AGT (MAK10)

Description	Part No.	Fitted in	WP	SP	Requirement per x year(s)
Spare filter cartridge, Teflon	5 320 090	Sample gas cooler MAK10	X		1 pc./ 2 y.
Hose pump SR25, complete 115/230V 50/60Hz IP00, 5 rpm, incl. hose Novoprene and 2 pcs. hose sockets	6 039473	Sample gas cooler MAK10		X	1 pc./ 2 y.
Spare parts set, hose pump SR25 comprising: 5 pcs. pump hose 4.8x1.6 Novoprene, 1 pc. bearing surface	2 050 587	Sample gas cooler MAK10	X		3 pcs./ 2 y.

Condensate pump SR25

Description	Part No.	Fitted in	WP	SP	Requirement per x year(s)
Hose pump SR25, complete 115/230V, 50/60Hz, IP00, 5 rpm. 1 duct, 2 rollers on assembly bracket Hose 4.8 x 1.6 Novoprene - 0.4 l/h with 2 hose sockets 5 mm	6027 131			X	1 pc./ 2 y.
Spare parts set, hose pump SR25 comprising: 5 pcs. pump hose 4.8 x 1.6 Novoprene 1 pc. bearing surface	2 027 976	Hose/condensate pump SR25	X		3 pcs./ 2 y.
Hose pump, type SR25 5 RPM 5 RPM / N4.8x1.6 239/115 V, 50-60 Hz	6 026 412			X	1 pc./ 2 y.
Hose pump, type SR25.1 230 V / 50 Hz; 115 V / 60 Hz (01P1000)	6 021 783			X	1 pc./ 2 y.

8.6.2 SP/WP for external components

Sample gas probe SP10, SP10-H					
Description	Part No.	Fitted in	WP	SP	Requirement per x year(s)
Stainless steel filter frit, type V10	5 313 358	Gas sampling probe SP10		X	1 pc./ 2 y.
Stainless steel filter frit, type V10-1 with volume displacer	6 012 394	Gas sampling probe SP10		X	1 pc./ 2 y.
Seal 1" for SP10 V10	5 306 553	Gas sampling probe SP10		X	1 pc./ 2 y.
Flange seal DN65 PN6B [67]	5 313 427	Gas sampling probe SP10		X	1 pc./ 1 y.
Heating cartridge HLP for SP10H, filter H/H0, L=130 mm, 230 VAC / 315W	6 012 395	Gas sampling probe SP10-H		X	2 pcs./ 1 y.
Heat-conductive paste for heating cartridge insertion	5 602 693	Gas sampling probe SP10-H		X	1 pc./ 1 y.
Excess temperature limiter	6 012 401	Gas sampling probe SP10-H		X	1 pc./ 1 y.

Sample gas probe SP210-H; SP210-H/W					
Description	Part No.	Fitted in	WP	SP	Requirement per x year(s)
Parts set SP210, comprising: 4 pcs. Viton flat seal [30] (5306634) 2 pcs. filter element SP-2K (5308926) 2 pcs. O-ring set (5308928) 2 pcs. O-ring set [94], Viton (5312366) 2 pcs. lid seal (5312367)	2 031 994	Gas sampling probe SP210-H	X		1 pc./ 1 y.
Flange seal DN65 PN6B [67]	5 313 427			X	1 pc./ 1 y.
Thermostatic switch	6 027 810			X	1 pc./ 1 y.
Heating cartridge HLPSR	6 027 809			X	2 pcs./ 1 y.
Heat-conductive paste for heating cartridge insertion	5 602 693			X	1 pc./ 1 y.

Sample gas probe SP2000; SP2000-H					
Description	Part No.	Fitted in	WP	SP	Requirement per x year(s)
Parts set SP2000, comprising: 4 pcs. Viton flat seal [30] (5306634) 2 pcs. filter element S-2K150 (6012411) 2 pcs. O-ring [55], Viton (5306625) 2 pcs. O-ring [39], Viton (5306624)	2 030 462	Gas sampling probe SP2X00	X		1 pc./ 1 y.
Flange seal DN65 PN6B [67]	5 313 427	Gas sampling probe SP2000		X	1 pc./ 1 y.
Heating cartridge HLP	6 012 408	Gas sampling probe SP2000-H		X	2 pcs./ 1 y.
Heat-conductive paste for heating cartridge insertion	5 602 693	Gas sampling probe SP2000-H		X	1 pc./ 1 y.

8.7

Further and supplementary spare/wearing parts

Refer to Data Sheets / Operating Instructions of the respective system components for further information on spare/wearing parts as required.

MKAS

9 Clearing Malfunctions

Fuses

Status messages / group alarms

Implausible measuring results

9.1 **Fuses**

- ▶ Check correct condition of fuses according to the wiring diagrams
- ▶ Refer to the Operating Instructions / Data Sheets of the system components for details

9.2 **Status indicators / group alarms**

The following messages are displayed resp. output:

- Creation of a group alarm on the analysis system
(refer to wiring diagram MKAS analysis system for details)
- Status indicators on the analyzer display (display messages, significance, cause / information and service information, refer to Operating Instructions of analyzer)
- Status indicators / clear text messages on the LOGO control display

9.3 **Implausible measuring results**

First check the following for implausible measuring results:

- ▶ Whether the specified and elementary process conditions are complied with
- ▶ Whether the sample gas path shows signs of leaks

Refer to the Operating Instructions of the analyzer for further possible causes and information on implausible measuring results resp. on measured values that are obviously incorrect or fluctuate for no apparent reason.

Switch-on conditions / additions to clearing malfunctions

Note:

Switch-on conditions are set for the MKAS analysis system at the factory. These serve the safety resp. function monitoring of particular analysis system components and are realized using signal status queries for these components.

Depending on the version of the MKAS analysis system, status signal queries run either via:

- A signal series connection
- The analyzer
- The LOGO! (small control system)
- A PLC control
- ▶ Refer to the wiring diagram of the MKAS analysis system for the specific parameter settings and version resp. determination of switch-on conditions.



NOTICE:

- The switch-on conditions configured at the factory must not be deactivated.
- Non-observance resp. deactivation of the switch-on conditions can cause severe damage.

The following status parameters are queried, for example, to fulfill the switch-on conditions:

- Gas sampling probe (option)
 - Nominal temperature monitoring for heated gas sampling probes (option)
 - Monitoring runs via a low temperature alarm contact integrated in the sample gas probe.
 - A status signal is released confirming fulfillment of the switch-on conditions when the nominal value setting is maintained.
 - Refer to the wiring diagram of the MKAS analysis system resp. the Operating Instructions of the sample gas probe for the nominal value set or to be set depending on the probe type and system version.
- Sample gas line (option)
 - Heating function monitoring for regulated, heated sample gas lines (option)
 - A status signal is released by the temperature controller confirming fulfillment of the switch-on conditions when the nominal value setting is maintained. Refer to the wiring diagram of the MKAS analysis system for the Operating Instructions for the nominal values set depending on the system.
- NOx converter (option)
 - Function monitoring of converter
 - When no operating malfunction of the converter is present, a status signal to confirm fulfillment of the switch-on condition is released when the operating temperature (nominal temperature) is reached.
- Sample gas cooler
 - Function monitoring of cooler (status query)
 - When no operating malfunction of the cooler is present, a status signal to confirm fulfillment of the switch-on condition is released when the operating temperature (cooling temperature) is reached.
- Level sensor
 - Monitoring of filling level in condensate collection container.
 - A status signal to confirm fulfillment of the switch-on condition is released as long as the specified maximum filling level of the condensate collection container has not been reached.

- Analyzer
To monitor analyzer failure resp. to monitor / query its self-diagnosis function (for internal monitoring parameters such as e.g. temperature, flow, moisture), a status signal is either passed to a potential-free reporting terminal or evaluated by a LOGO! / PLC control (optional) when used.
- Pump function
The pump function of the sample gas pump is controlled by the analyzer. A status signal confirming fulfillment of the switch-on condition is released when the sample gas pump is activated (operation). When using a LOGO! / PLC control (optional), this can also monitor the pump function (gas flow).

MKAS

10 Specifications

Declaration of conformity

Approvals

Parameter lists

Technical data

10.1

Compliances

The technical version of this device complies with the following EU directives and EN standards:

- EU Directive: LVD (Low Voltage Directive)
- EU Directive: EMC (Electromagnetic Compatibility)

Applied EN standards:

- EN 61010-1, Safety requirements for electrical equipment for measurement, control and laboratory use
- EN 61326, Electrical equipment for measurement technology, control technology and laboratory use - EMC requirements



10.1.1

Electrical protection

- Insulation: Class of protection 1 according to EN 61010-1.
- Insulation coordination: Measuring category II according to EN61010-1.
- Contamination: The device operates safely in an environment up to contamination level 2 according to EN 61010-1 (usual, non-conductive contamination and temporary conductivity by occasional moisture condensation).
- Electrical power: The wiring system to the mains supply voltage of the system must be installed and fused according to the relevant regulations.

10.2

Dimensions

Refer to the view drawings resp. wiring diagram in the System Documentation for dimensions.

10.3 **Technical Data**

Technical Data	MKAS
Versions	<ul style="list-style-type: none"> • Standard version • Version with NO/ NOx converter (option) • Cabinet climate control and/or heating (option) • DAU (option)
Analyzer	<ul style="list-style-type: none"> • Modular gas analyzer(s) S710 (see product information) • Gas analyzer(s) SIDOR (see product information)
Measuring components (possible)	CO, NO, SO ₂ , CO ₂ , H ₂ , CH ₄ , O ₂ and others (according to the analyzer, see System Documentation)
Output and status signals	Typically 4 ... 20 mA (according to the analyzer, see System Documentation)
Sample Requirements	
Sample gas throughput	Approx. 30 ... 100 l/h (larger sample throughput possible depending on the system)
Sample gas temperature	Max. 200 °C at cabinet inlet
Dew point H ₂ O	65 °C maximum.
General Data	
Conditions at installation location	<ul style="list-style-type: none"> • Under a roof with protection against direct heat radiation, heavy dust load and corrosive atmosphere. • Not suitable for potentially explosive atmospheres
Auxiliary power supply	Refer to the system-specific wiring diagram resp. System Documentation for specifications on nominal power/voltage/rating. Possible variants are e.g.: <ul style="list-style-type: none"> • 400V, 50Hz (optional) • 400V, 60Hz (optional) • 230V, 50Hz (optional) • 230V, 60Hz (optional) • 115V, 50Hz (optional) • 115V, 60Hz (optional) • UPS (optional)
Frost protection (optional)	Nominal capacity 500 VA
Ambient temperature in operation	+5 ... +35 °C ^[1] , +5 ... 50 °C with built-in cooling unit
Transport and storage temperature	-20 ... +55 °C
Relative humidity	Class F (DIN 40040), 75 % yearly average, 95 % short-term, non-condensing
Sample gas pump	<ul style="list-style-type: none"> • Pump (internal) in analyzer conditionally adequate up to 15 m sample gas line • Pump (external) in MKAS analysis system cabinet (option) conditionally adequate for up to 35 m sample gas line (optional, longer lengths with more powerful pumps).
Dimensions (W x H x D)	(See view drawings resp. wiring diagram in the System Documentation)
Protection class	• IP 54 • IP 34 with cooling unit
Weight	Approx. 250 kg to 350 kg
Material	<ul style="list-style-type: none"> • Steel sheet enclosure (see System Documentation) • GRP (see System Documentation)
Color	• RAL 7035 (standard) • (other colors optional)
Calibration	<ul style="list-style-type: none"> • Manual, test gas feed manual or automatic • Automatic (according to the analyzer, see System Documentation)
Signals	1 analog output / component
Interfaces	• RS232 (optional) • RS422 (optional) • RS485 (optional)
Bus interfaces	<ul style="list-style-type: none"> • Modbus (optional) • Profibus (optional)

[1]No direct sunlight

A	
Additional documentation (information)	9
Adjustment	40
Adjustment procedure	40
Adsorbent	30
Air outlet	16
Analyzer	17, 32
B	
Bubbling frits, inserting	23
C	
Cabinet climate control	33
CAN bus	2
CompactFlash disc	2
Compliance	64
Condensate container (location)	18
Control	2
D	
DAU	2, 9, 17, 32
Disposal	46
E	
EPC	2
Error messages	60
ESD	2
Ethernet	2
F	
Fan	16
Fieldbus	2
Filter (location)	18
Filter elements, inserting	23
Firewall	2
Flowmeter	18
Functional principle	13
Fuses	60
- Location	18
G	
Gas flow plan	19
Gas sampling probe	34
Gas warning system	34
Glossary	2
Group alarms	60
H	
Humidifier containers	30
I	
Information Symbols	3
Intended use	8
Interfaces	15
L	
LEL	2
LOGO!	2, 9
LWL Module	2
M	
Main switch	16
Maintenance	47
Maintenance intervals	50
Maintenance signal	49
MEAC 2000 software	2
MEAC2000	9, 32
Measuring components	14
Modbus	2
N	
Needle valve (location)	18
NOx converter	2, 17, 32
NOx converter cartridge	24
O	
OLE	2
OPC	2
P	
PLC	2
Product description	11
Product identification	12
Profibus	2
Project planning	22
R	
Raschig rings	2
S	
Sample gas cooler	31
- Location	18
Sample gas inlet and outlet	18
Sample gas pump (location)	18
Shutdown	41
Signal words	3
Solenoid	18
Solenoid valves	18
SOPAS	2
SOPAS-ET	2
Span gas	2
Spare parts	52
Specifications	63
Status indicators	60
Storage	45
Switching on	31
Symbols (explanation)	3

T

TCP/IP 2
Technical data 65
Terminal strips (location) 18
Transport safety devices 23
Type plate 12

U

UPS 2

W

Warning symbols, warning levels 3
Washing bottles 30
Wearing parts 52
Wiring diagram 2

MKAS

8013230/V 1.1./2012-07 | Subject to change without notice

SICK worldwide

You will find our local subsidiary
or agency at:

www.sick.com

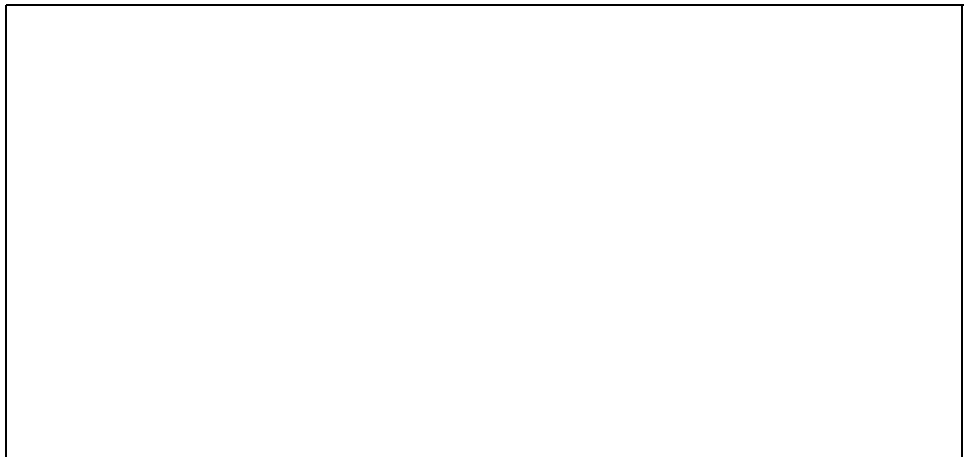

Your local sales and service partner