

CFS50 plug-in shaft

Motor feedback systems



Described product

CFS50 plug-in shaft

Manufacturer

SICK AG
Erwin-Sick-Str. 1
79183 Waldkirch
Germany

Legal information

This work is protected by copyright. Any rights derived from the copyright shall be reserved for SICK AG. Reproduction of this document or parts of this document is only permissible within the limits of the legal determination of Copyright Law. Any modification, abridgment or translation of this document is prohibited without the express written permission of SICK AG.

The trademarks stated in this document are the property of their respective owner.

© SICK AG. All rights reserved.

Original document

This document is an original document of SICK AG.



Motor feedback systems are measuring instruments produced in Accordance with recognized industrial regulations.

- ▶ The installation of the motor feedback system is to be carried out by trained personal with knowledge of electrical engineering and precision engineering.
- ▶ A motor feedback system must be used only for the purpose appropriate to its design.

1 Safety notes

**WARNING**

- ▶ Observe the professional safety regulations and accident prevention regulations applicable to your country.
 - ▶ Switch off the voltage for all devices/machines and systems affected by the assembly.
 - ▶ Impacts and shocks to the shaft **MUST** be avoided, as this may lead to damage to the ball bearings.
 - ▶ Use suitable flexible shaft couplings. The suitability of the coupling depends on the occurring angle and shaft offset, acceleration, temperature, speed and bearing load permitted for the motor feedback system, as stipulated by the motor feedback system datasheet.
 - ▶ Never make or undo electrical connections to the motor feedback system when voltage is applied, otherwise this may result in damage to the devices.
 - ▶ Never pull or press the motor feedback system housing.
 - ▶ Do not bring rubber housings into contact with adhesive (e. g. Loctite 241, 243) since the dimethyl acrylate ester, which it contains, dissolves the surface.
 - ▶ When using this type of encoder, a suitable method of strain relief must be used to secure the stranded cable assembly.
-

2 Tools/ parts required

Mounting using the threaded flange holes requires M4 screws. The length as well as the screw head type will depend on the fitting conditions. Fixing via the servo groove requires servo clamps and M4 screws; select the screw length according to the fitting conditions.

3 Preparation for attachment

Remove protective foil (versions for integration), if present, on the back of the motor feedback system.

Degrease the drive shaft and the shaft of the motor feedback system.



WARNING
Beware of damage!

4 Generally applicable notes

Using the stator coupling for the motor feedback systems, the housing must be correctly seated in the customers flange arrangement. The more precise the centring for the motor feedback system, the less the angle and shaft offset during assembly and the less load on the coupling and the bearing of the motor feedback system. EMC considerations make it mandatory to connect the device housing and the cable screen, resp., to earth. This may be effected via the housing of the mating connector and by connecting the braided screen of the cable, resp. The braided screen should be connected over a large area.



CAUTION

To ensure trouble-free operation, it is imperative to ensure a clean screen connection on both sides.

5 CFS50 with plug-in shaft and resolver style support

5.1 Assembly

- ▶ Block customer's drive shaft to prevent rotation.
- ▶ Screw pressing tool onto the B-side encoder shaft end (2). Spray activator onto the encoder shaft (7) and into the hole of the drive shaft. Thinly apply adhesive onto the encoder shaft (7). Plug encoder shaft (7) in drive shaft and continuously press, with the pressing tool, up to the stop. Do not hit with a hammer or similar tool!

5.2 Pressing force required Pressing force required = 250 N–500 N.

- ▶ Ensure that the stator coupling (3) is squarely placed in the centering of the motor. Tighten the screw.
- ▶ Remove pressing tool.
- ▶ Fix the torque support (3) to the motor, in at least 3 places. The fixing can, for instance, be effected via servo clamps (4) and screws (5) or with clamping claws and clamping ring.
- ▶ Connect the set of strands volt-free (6).
- ▶ Only test encoders function after the adhesive is fully cured (8 hours approx.) and, at this time, do not make any mechanical adjustments such as commutation.

5.3 Disassembly

- ▶ Block customer's drive shaft to prevent rotation.
- ▶ Undo electrical connection volt-free. Undo and remove fixing screws of the stator coupling.

6 PIN and wire allocation CFS50



WARNING

PIN allocation only valid for standard motor feedback encoders. For customer specific versions please see the relevant data sheet.

PIN	Colour	Signal
1	blue	Ground (GND)
2	red	Supply voltage 5 V \pm 10% (U_s)
3	yellow	Reference signal inverted (\bar{Z})
4	purple	Reference signal (Z)
5	brown	Incremental signal inverted (\bar{A})
6	white	Incremental signal (A)
7	black	Incremental signal inverted (\bar{B})
8	pink	Incremental signal (B)
9	white/red	Commutation signal inverted (\bar{T})
10	white/grey	Commutation signal (T)
11	white/blue	Commutation signal inverted (\bar{S})
12	white/yellow	Commutation signal (S)
13	white/pink	Commutation signal inverted (\bar{R})
14	white/green	Commutation signal (R)
15	grey	Setting reference signal for commutation tracks (SET0)

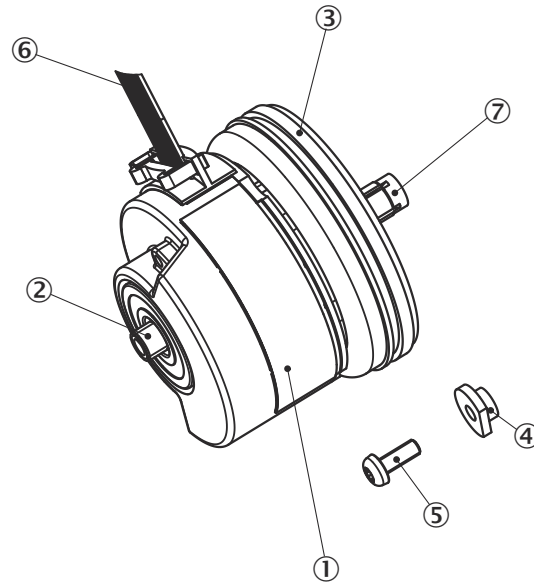

Figure 1: Motor feedback system with plug-in shaft and resolver style support

7 Annex

7.1 Conformities and certificates

You can obtain declarations of conformity, certificates, and the current operating instructions for the product at www.sick.com. To do so, enter the product part number in the search field (part number: see the entry in the “P/N” or “Ident. no.” field on the type label).