



DWS520 Static System solutions

Measuring size and weight for all shapes

Measuring size and weight for all shapes



Product description

For the complete data capture of volume, weight and bar code information of freight for the courier, express, postal and cargo industry as well as for retail and warehousing, SICK developed the new DWS520 Static dimensioning weighing scanning system.

By simply pushing the scan button of the hand-held scanner, the DWS520 Static measures dimensions and weight of the parcel lying on the integrated roller conveyor. This data can be used for invoicing freight charges or it can be used in ERP systems to create freight documents automatically.

The DWS520 Static is the big brother of the DWS510 Static, using the double-headed VMS520 volume measurement system. Therefore it can dimension also non-cuboidal objects legal for trade, which is unique on the market for static DWS systems.

The system consists of the well-known VMS520 volume measurement system, a robust static scale and a hand-held bar code scanner, which are all integrated into a rugged steel frame.

At a glance

- Dimensioning, weighing and identification data with the push of a button
- Complete solution with integrated frame and roller conveyor
- Commissioning within a few minutes
- Legal-for-trade approved (according to OIML, MID and NAWI)
- Special versions for irregular and oversized objects available

Your benefits

- 20 % higher dimensioning rates in average by also measuring irregular shaped objects (e. g. damaged parcels) providing faster return on investment
- Economic alternative to expensive fully-automatic DWS systems
- “Ready to measure out of the box”: completely pre-installed system reduces commissioning costs to almost zero
- Several freely programmable host interfaces can be used to generate additional data for sorting parcels

A cooperation with
AKL-tec
BIZERBA
 ... closer to your business



Additional information

Detailed technical data.....3
 Ordering information.....3
 Dimensional drawings3

→ www.mysick.com/en/DWS520_Static
 For more information, just enter the link or scan the QR code and get direct access to technical data, CAD design models, operating instructions, software, application examples and much more.



Detailed technical data

Performance

	DWS520-ST22100	DWS520-ST32100 Extended
Authorizations	Legal-for-trade approvals (OIML, MID and NAWI)	
Minimum object size	50 mm x 50 mm x 50 mm	
Maximum object size	1,200 mm x 800 mm x 800 mm	1,800 mm x 900 mm x 900 mm
Accuracy of object coverage	± 5 mm x ± 5 mm x ± 5 mm	
Allowed weight for legal-for-trade weighing	0.1 kg ... 60 kg	
Accuracy of scale	e = 20 g	
Throughput	Approx. 500 pph (measuring time approx. 1.5 sec per object), depending on operator	Approx. 300 pph (measuring time approx. 2 sec per object), depending on operator
Identification of parcels	Robust IDM160 hand-held bar code scanner fitted with a cable for all standard 1D bar codes, reading distance of up to 800 mm, minimum module width 0.076 mm (other hand-held scanner types available upon request)	

Interfaces

Serial (RS-232, RS-422)	✓
Ethernet	✓
PROFIBUS	✓

Mechanics/electronics

	DWS520-ST22100	DWS520-ST32100 Extended
Dimensions of the roller conveyor	L = 1,400 mm x B = 800 mm, Height above floor: adjustable from 700 mm to 950 mm (in 50 mm-steps)	L = 2,000 mm x B = 900 mm, Height above floor: adjustable from 700 mm to 950 mm (in 50 mm-steps)

Ordering information

- Sub product family: DWS520 Static

Model name	Part no.
DWS520-ST22100	On request
DWS520-ST32100 Extended	On request

Dimensional drawings

Dimensions in mm (inch)

DWS520-ST22100

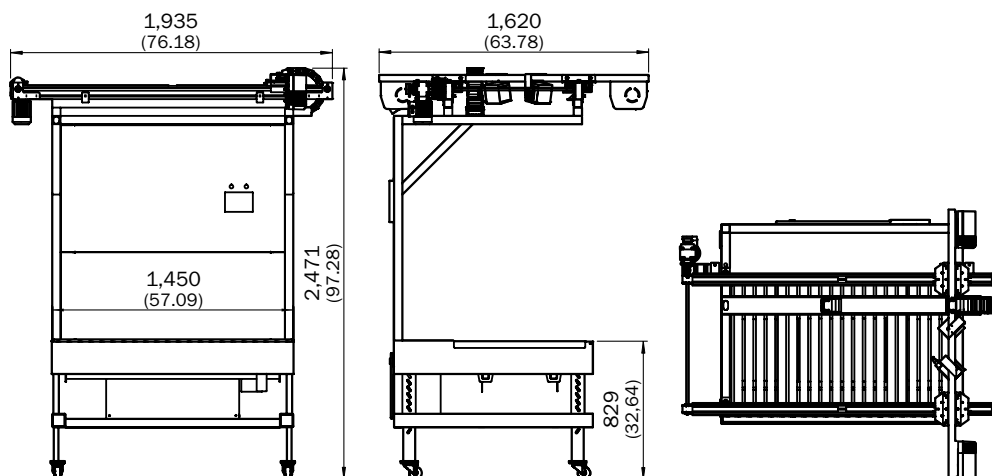

Note: Dimensional drawings for the DWS520-ST32100 Extended on request

SICK at a glance

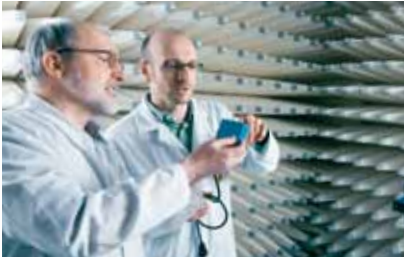

Leading technologies

With a staff of more than 5,000 and over 50 subsidiaries and representations worldwide, SICK is one of the leading and most successful manufacturers of sensor technology. The power of innovation and solution competency have made SICK the global market leader. No matter what the project and industry may be, talking with an expert from SICK will provide you with an ideal basis for your plans – there is no need to settle for anything less than the best.



Unique product range

- Non-contact detecting, counting, classifying, positioning and measuring of any type of object or media
- Accident and operator protection with sensors, safety software and services
- Automatic identification with bar code and RFID readers
- Laser measurement technology for detecting the volume, position and contour of people and objects
- Complete system solutions for analysis and flow measurement of gases and liquids



Comprehensive services

- SICK LifeTime Services – for safety and productivity
- Application centers in Europe, Asia and North America for the development of system solutions under real-world conditions
- E-Business Partner Portal www.mysick.com – price and availability of products, requests for quotation and online orders

Worldwide presence with subsidiaries in the following countries:

Australia
Belgium/Luxembourg
Brasil
Česká Republika
Canada
China
Danmark
Deutschland
España
France
Great Britain
India
Israel
Italia
Japan

México
Nederland
Norge
Österreich
Polska
România
Russia
Schweiz
Singapore
Slovenija
South Africa
South Korea
Suomi
Sverige
Taiwan
Türkiye
United Arab Emirates
USA

Please find detailed addresses and additional representatives and agencies in all major industrial nations at www.sick.com