

deTem4 Core A/P

Safety multibeam sensor

SICK
Sensor Intelligence.



Described product

deTem4 Core A/P

Manufacturer

SICK AG
Erwin-Sick-Str. 1
79183 Waldkirch
Germany

Legal information

This work is protected by copyright. Any rights derived from the copyright shall be reserved for SICK AG. Reproduction of this document or parts of this document is only permissible within the limits of the legal determination of Copyright Law. Any modification, abridgment or translation of this document is prohibited without the express written permission of SICK AG.

The trademarks stated in this document are the property of their respective owner.

© SICK AG. All rights reserved.

Original document

This document is an original document of SICK AG.



Contents

1	About this document.....	6
1.1	Function of this document.....	6
1.2	Scope.....	6
1.3	Target groups of these operating instructions.....	6
1.4	Additional information.....	6
1.5	Symbols and document conventions.....	7
2	Safety information.....	8
2.1	General safety notes.....	8
2.2	Intended use.....	8
2.3	Improper use.....	8
2.4	Requirements for the qualification of personnel.....	9
3	Product description.....	10
3.1	Setup and function.....	10
3.2	Product characteristics.....	11
3.2.1	Device overview.....	11
3.2.2	Alignment aid.....	12
3.2.3	Near Field Communication (NFC).....	13
3.2.4	Status indicators.....	13
3.3	Example applications.....	15
4	Project planning.....	16
4.1	Manufacturer of the machine.....	16
4.2	Operating entity of the machine.....	16
4.3	Design.....	16
4.3.1	Scanning range and beam separation.....	17
4.3.2	Minimum distance from the hazardous point.....	17
4.3.3	Minimum distance from reflective surfaces.....	19
4.3.4	Protection against interference from systems in close proximity to each other.....	21
4.4	Integration in the electrical control system.....	22
4.4.1	Restart interlock.....	24
4.4.2	External device monitoring (EDM).....	24
4.4.3	Connection diagrams.....	25
4.5	Testing plan.....	26
4.5.1	Test rod check.....	27
4.5.2	Visual check of the machine and the protective device.....	28
5	Mounting.....	30
5.1	Unpacking.....	30
5.2	Mounting.....	30
5.2.1	Mounting the QuickFix bracket.....	33
5.2.2	Mounting the FlexFix bracket.....	35

5.2.3	Mounting optional Compact FlexFix bracket.....	37
5.2.4	Mounting flat mount bracket.....	39
5.2.5	Mounting swivel mount bracket.....	41
5.2.6	Mounting the replacement bracket.....	43
6	Electrical installation.....	44
6.1	Connecting.....	44
6.1.1	System connection (M12, 5-pin).....	44
7	Commissioning.....	45
7.1	Overview.....	45
7.2	Switching on.....	45
7.3	Alignment of the active and passive units.....	45
7.3.1	Aligning the active and passive units.....	46
7.3.2	Alignment with the QuickFix bracket.....	46
7.3.3	Alignment with the FlexFix bracket or with the replacement bracket.....	47
7.3.4	Alignment with the Compact FlexFix bracket.....	48
7.3.5	Alignment with the swivel mount bracket.....	49
7.3.6	Indication of the alignment quality.....	50
7.4	Check during commissioning and modifications.....	51
8	Operation.....	52
8.1	Overview.....	52
8.2	Regular thorough check.....	52
8.3	LEDs.....	53
9	Maintenance.....	54
9.1	Regular cleaning.....	54
9.2	Regular thorough check.....	55
10	Troubleshooting.....	56
10.1	Overview.....	56
10.2	Safety.....	56
10.3	Diagnostic LEDs.....	56
10.3.1	Status indicator.....	57
10.3.2	Fault indicators.....	58
11	Decommissioning.....	59
11.1	Disposal.....	59
12	Technical data.....	60
12.1	Data sheet.....	60
12.2	Length of cable.....	62
12.3	Table of weights.....	62
12.4	Dimensional drawings.....	63
13	Ordering information.....	66

13.1	Scope of delivery.....	66
13.2	Ordering information.....	66
14	Accessories.....	67
14.1	Brackets.....	67
14.2	Mounting accessories.....	69
14.3	Weld spark guard.....	70
14.4	Connectivity.....	70
14.5	Alignment aid.....	71
14.6	Device columns.....	72
14.7	Cleaning agent.....	72
14.8	Test rods.....	72
15	Annex.....	73
15.1	Conformities and certificates.....	73
15.1.1	EU declaration of conformity.....	73
15.1.2	UK declaration of conformity.....	73
15.2	Note on standards.....	73
15.3	Checklist for initial commissioning and commissioning.....	75
16	List of figures.....	76
17	List of tables.....	77

1 About this document

1.1 Function of this document

These operating instructions contain the information needed during the life cycle of the safety multibeam sensor.

Operating instructions of the safety multibeam sensor must be made available to all people who work with the device.

Please read these operating instructions carefully and make sure that you understand the content fully before working with the safety multibeam sensor.

1.2 Scope

Product

This document applies to the following products:

- Product code: deTem4 Core A/P
- "Operating instructions" type label entry: 8024639

Document identification

Document part number:

- This document: 8024740
- Available language versions of this document: 8024639

You can find the current version of all documents at www.sick.com.

1.3 Target groups of these operating instructions

Some sections of these operating instructions are intended for certain target groups. However, the entire operating instructions are relevant for intended use of the product.

Table 1: Target groups and selected sections of these operating instructions

Target group	Sections of these operating instructions
Project developers (planners, developers, designers)	"Project planning", page 16 "Technical data", page 60 "Accessories", page 67
Installers	"Mounting", page 30
Electricians	"Electrical installation", page 44
Safety experts (such as CE authorized representatives, compliance officers, people who test and approve the application)	"Project planning", page 16 "Commissioning", page 45 "Technical data", page 60 "Checklist for initial commissioning and commissioning", page 75
Operators	"Operation", page 52 "Troubleshooting", page 56
Maintenance personnel	"Maintenance", page 54 "Troubleshooting", page 56

1.4 Additional information

www.sick.com

The following information is available on the Internet:

- Data sheets and application examples
- CAD data and dimensional drawings

- Certificates (e.g. EU declaration of conformity)
- Guide for Safe Machinery Six steps to a safe machine

1.5 Symbols and document conventions

The following symbols and conventions are used in this document:

Safety notes and other notes



DANGER

Indicates a situation presenting imminent danger, which will lead to death or serious injuries if not prevented.



WARNING

Indicates a situation presenting possible danger, which may lead to death or serious injuries if not prevented.



CAUTION

Indicates a situation presenting possible danger, which may lead to moderate or minor injuries if not prevented.



NOTICE

Indicates a situation presenting possible danger, which may lead to property damage if not prevented.



NOTE

Indicates useful tips and recommendations.

Instructions to action

- ▶ The arrow denotes instructions to action.
- 1. The sequence of instructions for action is numbered.
- 2. Follow the order in which the numbered instructions are given.
- ✓ The check mark denotes the result of an instruction.

LED symbols

These symbols indicate the status of an LED:

- The LED is off.
- ◐ The LED is flashing.
- The LED is illuminated continuously.

Active and passive units

These symbols indicate the active and passive unit of the device:



This symbol indicates the active unit.



This symbol indicates the passive unit.

2 Safety information

2.1 General safety notes

Product integration



DANGER

The product can not offer the expected protection if it is integrated incorrectly.

- ▶ Plan the integration of the product in accordance with the machine requirements (project planning).
 - ▶ Implement the integration of the product in accordance with the project planning.
-

Mounting and electrical installation



DANGER

Death or severe injury due to electrical voltage and/or an unexpected startup of the machine

- ▶ Make sure that the machine is (and remains) disconnected from the voltage supply during mounting and electrical installation.
 - ▶ Make sure that the dangerous state of the machine is and remains switched off.
-

Repairs and modifications



DANGER

Improper work on the product

A modified product may not offer the expected protection if it is integrated incorrectly.

- ▶ Apart from the procedures described in this document, do not repair, open, manipulate or otherwise modify the product.
-

2.2 Intended use

The deTem4 Core A/P safety multibeam sensor is an electro-sensitive protective device (ESPE) and is suitable for the following applications:

- Single-sided access protection

The product may be used in safety functions.

The deTem4 Core A/P safety multibeam sensor must only be used within the limits of the prescribed and specified technical data and operating conditions at all times.

Any instance of improper use, incorrect modification, or manipulation of the deTem4 Core A/P safety multibeam sensor shall void any warranty provided by SICK AG; furthermore, SICK AG shall not accept any responsibility or liability for any resulting damage and consequential damage.

2.3 Improper use

The safety multibeam sensor works as an indirect protective measure and cannot provide protection from pieces thrown from the application nor from emitted radiation. Transparent objects are not detected.

Among others, the safety multibeam scanner is not suitable for the following applications:

- Outdoors
- Underwater
- In explosion-hazardous areas
- At altitudes over 3,000 m above sea level
- In environments with increased levels of ionizing radiation

2.4 Requirements for the qualification of personnel

The product must be configured, installed, connected, commissioned, and serviced by qualified safety personnel only.

Project planning

You need safety expertise to implement safety functions and select suitable products for that purpose. You need expert knowledge of the applicable standards and regulations.

Mounting, electrical installation and commissioning

You need suitable expertise and experience. You must be able to assess if the machine is operating safely.

Operation and maintenance

You need suitable expertise and experience. You must be instructed in machine operation by the machine operator. For maintenance, you must be able to assess if the machine is operating safely.

3 Product description

3.1 Setup and function

Overview

The deTem4 Core A/P safety multibeam scanner is an electro-sensitive protective device (ESPE) consisting of a sender and receiver unit (hereinafter referred to as the active unit) and a deflection unit (hereinafter referred to as the passive unit). The sender and receiver unit is located in the same housing.

The hazardous area is protected by the infrared light beams between the active unit and the passive unit on the opposite side. The infrared beams of the active unit hit the passive unit and are sent back to the active unit with a parallel offset.

When one or more light beams are completely interrupted, the protective device reports the interruption in the light path to the secure output signal switching devices (OSSDs) by a signal change. The machine or its control must safely analyze the signals (for example using a safe control or safety relays) and stop the dangerous state.

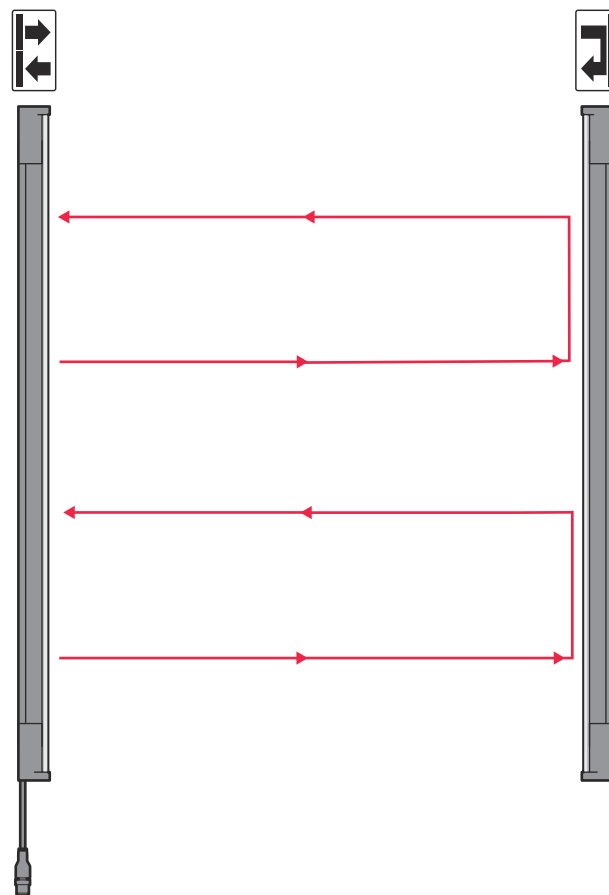

Figure 1: Active and passive units

Beam separation and number of beams

The beam separation is the distance between two adjacent light beams, measured from the center of one beam to the center of the next.

The beam separation and number of beams depend on the device variant.

Scanning range

The scanning range is the maximum dimension of the light path between active and passive units.

Depending on the passive unit used, a small or large scanning range can be achieved.

The scanning range is reduced by using a weld spark guard.

Further topics

- ["Data sheet", page 60](#)
- ["Weld spark guard", page 70](#)

3.2 Product characteristics

3.2.1 Device overview

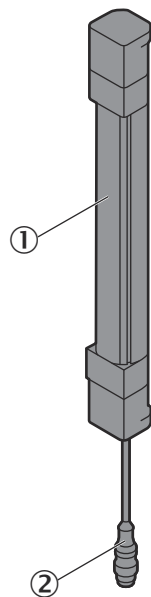

Figure 2: Overview of the active unit

- ① Active unit
- ② System connection

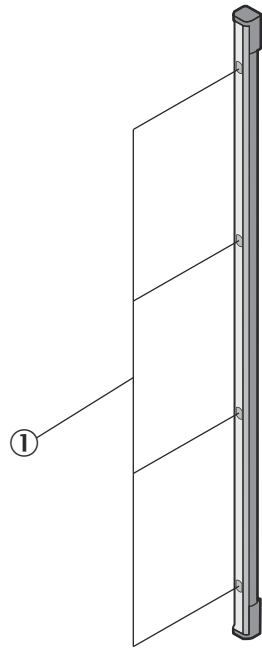

Figure 3: Overview of the passive unit for small scanning ranges

- ① Light guide deflection

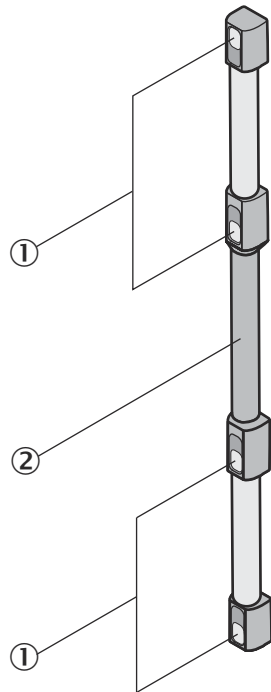

Figure 4: Overview of the passive unit for large scanning ranges

- ① Prismatic deflection
- ② Connection piece

3.2.2 Alignment aid

Diagnostic LEDs are installed in the active unit of the safety multibeam scanner. For a simple alignment of the passive unit, diagnostic LEDs 1 ... 8 indicate the alignment quality once the device has been switched on.

- In a system with 2 beams, the alignment quality is indicated via the diagnostic LEDs 1 ... 4.
- In a system with 4 beams, the alignment quality of the beams close to the system connection is indicated via the diagnostic LEDs 1 ... 4 and the alignment quality of the beams far from the system connection via the diagnostic LEDs 5 ... 8.

3.2.3 Near Field Communication (NFC)

Overview

The active unit of the safety multibeam scanner has an integrated NFC interface for transmitting diagnostic data of the protective device to an NFC-capable device.

The integrated NFC interface is intended for temporary use.

Diagnostic data

The following diagnostic data can be displayed in an NFC-capable device:

- Device information and device status, e.g. name, serial number, type code, status of OSSDs, or quality of alignment
- Fault diagnosis with specification of the error code, error description, diagnostic LED and troubleshooting

An NFC-capable antenna is integrated behind the front screen of the safety multibeam scanner for transmitting the data. The area is marked with the NFC symbol.



Figure 5: NFC symbol ¹⁾

Calling up diagnostic data

To be able to call up information, you need an NFC-capable device, e.g. a smartphone and the SICK Safety Assistant app provided by SICK.

- ▶ Hold the NFC-capable mobile device near the marked NFC-area on the lower end of the active unit to call up the diagnostic data.

Complementary information

The diagnostic data can also be read out in the voltage-free state of the protective device. However, you will receive more information if the protective device is supplied with voltage.

3.2.4 Status indicators

Overview

The LEDs of the active unit signal the operational status of the safety multibeam scanner.

¹⁾ The N-Mark is a trademark or registered trademark of NFC Forum, Inc. in the United States and in other countries.

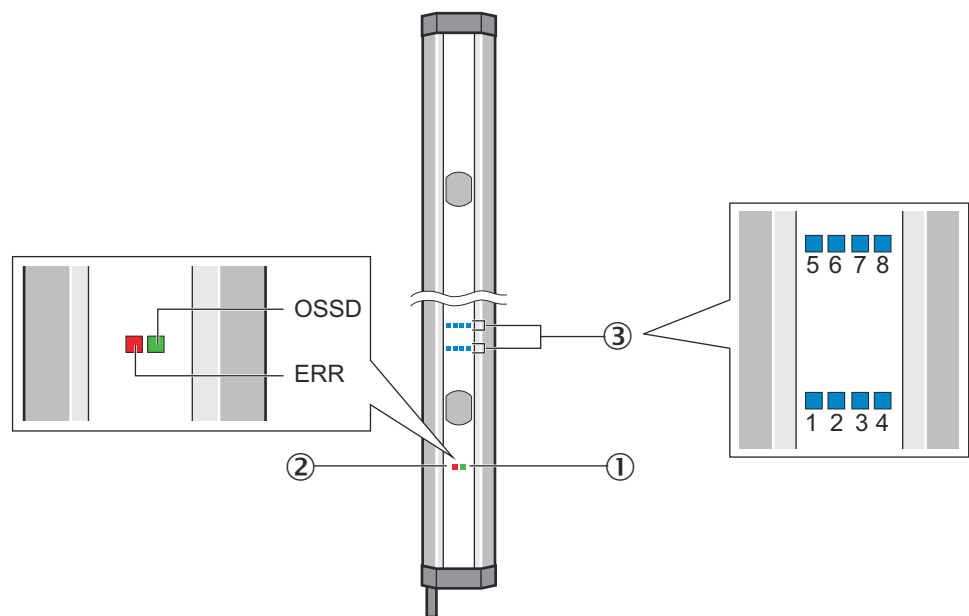

Figure 6: Status indicators of the active unit

Position	LED color	Display	Labeling
①	Red/green	OSSD status	OSSD
②	Red	Fault indication	ERR
③	Blue	Diagnostics	1, 2, 3, 4, 5, 6, 7, 8

The blue diagnostic LEDs in combination with the red flashing ERR LED also denote faults.

Further topics

- ["Diagnostic LEDs", page 56](#)

3.2.4.1 Indication of diagnostic LEDs

Table 2: Colors and their meaning

Color	Color	Meaning
●	Blue	Alignment quality
⦿	Blue	Fault indication

○ LED off. ⦿ LED flashes. ● LED illuminates.

Table 3: Indication of the alignment quality

Diagnostics LEDs	Color	Meaning
1 ... 4	● Blue	Display of the alignment quality for a system with 2 beams. If only one diagnostic LED lights up, the alignment is insufficient. If all 4 diagnostic LEDs light up, the alignment is excellent. OR Display of the alignment quality of the beams close to the system connection for a system with 4 beams. If only one diagnostic LED lights up, the alignment is insufficient. If all 4 diagnostic LEDs light up, the alignment is excellent.

Diagnostics LEDs	Color	Meaning
5 ... 8	● Blue	Display of the alignment quality of the beams far from the system connection for a system with 4 beams. If only one diagnostic LED lights up, the alignment is insufficient. If all 4 diagnostic LEDs light up, the alignment is excellent.

○ LED off. ● LED flashes. ● LED illuminates.

Table 4: Fault indication

Diagnostics LEDs	Color	Meaning
1 ... 8	● Blue	A blue flashing diagnostic LED signals the reason for the error.

○ LED off. ● LED flashes. ● LED illuminates.

Further topics

- ["Diagnostic LEDs", page 56](#)

3.3 Example applications

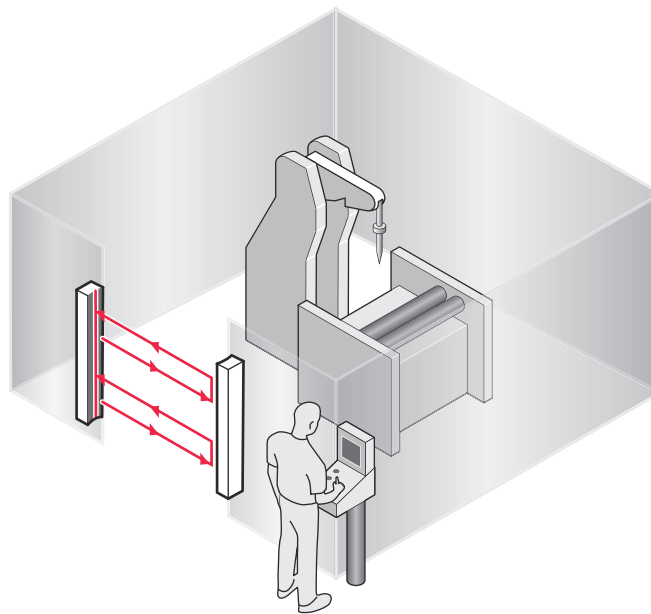

Figure 7: Access protection

4 Project planning

4.1 Manufacturer of the machine

The manufacturer of the machinery must carry out a risk assessment and apply appropriate protective measures. Further protective measures may be required in addition to the product.

The product must not be tampered with or changed, except for the procedures described in this document.

The product must only be repaired by the manufacturer of the product or by someone authorized by the manufacturer. Improper repair can result in the product not providing the expected protection.

4.2 Operating entity of the machine

Changes to the electrical integration of the product in the machine controller and changes to the mechanical mounting of the product necessitate a new risk assessment. The results of this risk assessment may require the entity operating the machine to meet the obligations of a manufacturer.

The product must not be tampered with or changed, except for the procedures described in this document.

The product must only be repaired by the manufacturer of the product or by someone authorized by the manufacturer. Improper repair can result in the product not providing the expected protection.

4.3 Design

Important information



DANGER

Hazard due to lack of effectiveness of the protective device

Persons and parts of the body to be protected may not be recognized in case of non-observance.

- ▶ Make sure that the following design requirements are met so that the safety multibeam scanner can fulfill its protective function.
 - The active and passive units must be arranged such that persons or parts of the body are safely detected when they enter the hazardous area.
 - Reaching under, over, and around as well as moving the safety multibeam scanner must be prevented.
 - Check whether additional safety measures (e.g. restart interlock) are necessary when it is possible for people to be located between the protective device and the hazardous point without being detected.
-

**DANGER**

Hazard due to lack of effectiveness of the protective device

Persons and parts of the body to be protected may not be recognized in case of non-observance.

- ▶ Make sure that the optical properties of the front screens of the active and passive units for small scanning ranges are not changed, e.g. by:
 - beading water, mist, frost, or ice formation. If applicable, remove films or other types of contamination, disconnect the voltage supply of the active unit and then switch it back on.
 - Scratches or damage. Replace the device if the front screen is scratched or damaged.
- ▶ Make sure that all reflective surfaces and objects maintain a minimum distance from the light beams.
- ▶ Make sure that no dispersive media (e.g., dust, fog, or smoke) are within the calculated minimum distance from the light beams.

**DANGER**

Hazard due to lack of effectiveness of the protective device

Certain types of light radiation can influence the protective device, e.g., light radiation from fluorescent lamps with electronic ballast installed in the path of the beam, or beams from laser pointers directed at the active unit.

- ▶ If this type of light radiation is present in the environment of the protective device, take additional measures to ensure that the protective device does not become dangerous.

Further topics

- ["Mounting", page 30](#)

4.3.1 Scanning range and beam separation**Beam separation and number of beams**

The beam separation is the distance between two adjacent light beams, measured from the center of one beam to the center of the next.

The beam separation and number of beams depend on the device variant.

Scanning range

The scanning range is the maximum dimension of the light path between active and passive units.

Depending on the passive unit used, a small or large scanning range can be achieved.

Further topics

- ["Minimum distance from reflective surfaces", page 19](#)
- ["Technical data", page 60](#)

4.3.2 Minimum distance from the hazardous point

A minimum distance must be maintained between the safety multibeam sensor and the hazardous point. This distance is required to prevent a person or part of the body from reaching the hazardous area before the dangerous state of the machine state has completed.

Calculating the minimum distance according to ISO 13855

The calculation of the minimum distance is based on international or national standards and statutory requirements applicable at the place of installation of the machine.

If the minimum distance is calculated according to ISO 13855, then it depends on the following points:

- Machine stopping time (time interval between triggering the sensor function and the end of the machine's dangerous state)
- Response time of the protective device
- Approach speed of personnel
- Type of approach: orthogonal (at right angles)
- Parameters specified based on the application

For the USA (scope of OSHA and ANSI), different regulations may apply, e.g.:

a) Laws: Code of Federal Regulations, Title 29 (CFR29) Part 1910.217

b) Standards: ANSI B11.19

Complementary information

Additional information is available in the ISO 13855 standard and in the Guidelines Safe Machinery.

SICK offers a stopping/run-down time measurement service in many countries.

Further topics

- ["Technical data", page 60](#)

4.3.2.1 Calculating minimum distance from the hazardous point

Important information



DANGER

Minimum distance from the hazardous point is too small

The dangerous state of the machine may not be stopped or not be stopped in a timely manner due to a minimum distance that is too small.

- ▶ Calculate the minimum distances for the machine in which the safety multibeam sensor is integrated.
 - ▶ When mounting the safety multibeam sensor, observe the minimum distance.
-

Approach

The example shows the calculation of the minimum distance for an orthogonal (at right angles) approach to the safety multibeam sensor. Depending on the application and the ambient conditions, a different calculation may be required (e.g., at a different angle to the direction of approach or an indirect approach).

1. Calculate S using the following formula:
$$S = 1,600 \text{ mm/s} \times T + C$$
where:
 - S = minimum distance in millimeters (mm)
 - T = machine stopping time + response time of the protective device after interruption in the light path in seconds (s)
 - C = supplement in accordance with ISO 13855:
 - If it is not possible to reach over the protective device: C = 850 mm
 - If it is possible to reach over the protective device, the value C_{RO} must be used for C in accordance with ISO 13855, provided that this is greater than 850 mm: $C \geq 850 \text{ mm}$ and $C \geq C_{RO}$

The reach/approach speed is already included in the formula.

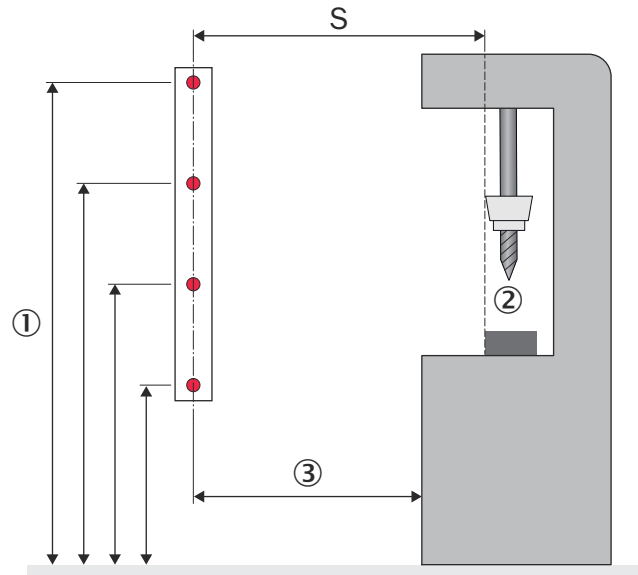

Figure 8: Minimum distance from the hazardous point

- ① Height of the light beams above ground
- ② Hazardous point
- ③ Depending on the application and distance, persons must be prevented from standing behind the protective device.

Example calculation

Machine stopping time = 290 ms

Response time after interruption of the light path = 20 ms

$$T = 290 \text{ ms} + 20 \text{ ms} = 310 \text{ ms} = 0.31 \text{ s}$$

$$S = 1,600 \text{ mm/s} \times 0.31 \text{ s} + 850 \text{ mm} = 1,346 \text{ mm}$$

4.3.3 Minimum distance from reflective surfaces

Overview

The light beams from the active unit may be deflected by reflective surfaces and dispersive media. This can prevent an object from being detected.

Therefore, all reflective surfaces and objects (e.g., material bins, machine table, etc.) must maintain a minimum distance (a) from the light beams. This minimum distance (a) must be maintained on all sides of the light beams. This applies in horizontal, vertical and diagonal directions as well as at the end of the protective device. The same area must be free of dispersive media (e.g., dust, fog, or smoke).

The minimum distance (a) depends on the distance (D) between active and passive unit.

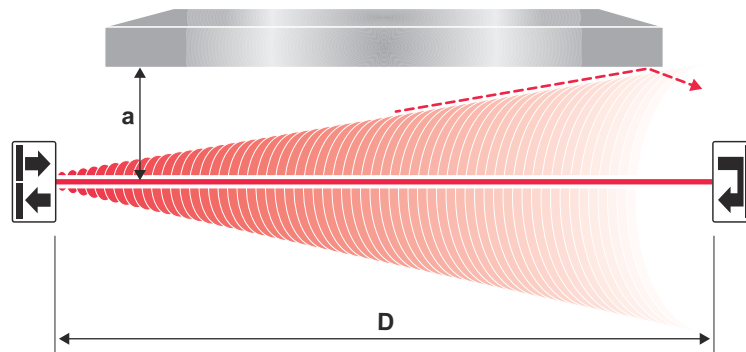

Figure 9: Minimum distance from reflective surfaces

Important information



DANGER

Hazard due to lack of effectiveness of the protective device

Reflective surfaces and dispersive media can prevent persons or parts of the body to be protected from being properly reflected and therefore, they remain undetected.

- ▶ Make sure that all reflective surfaces and objects maintain a minimum distance from the light beams.
- ▶ Make sure that no dispersive media (e.g., dust, fog, or smoke) are within the calculated minimum distance from the light beams.
- ▶ Make sure that there are no reflective surfaces behind the passive unit outside the maximum scanning range of 8 m (system with 2 beams) or 7 m (system with 4 beams) that could cause beam deflection.

Determining minimum distance to reflective surfaces

1. Determine the distance between active and passive units (D) in meters (m)
2. Read the minimum distance (a) in millimeters (mm) in the graph or calculate it based on the respective formula from [table 5](#):

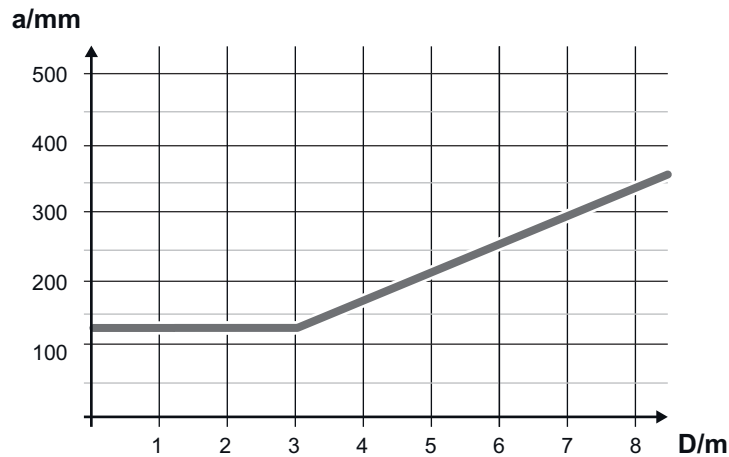

Figure 10: Graph of minimum distance from reflective surfaces

Table 5: Formula for calculating the minimum distance from reflective surfaces

Distance between active and passive units (D) in m	Calculating the minimum distance from reflective surfaces a in mm
$D \leq 3$ m	$a = 131$ mm

Distance between active and passive units (D) in m	Calculating the minimum distance from reflective surfaces a in mm
$D > 3$ m	$a = \tan(2.5^\circ) \times 1,000 \text{ mm/m} \times D = 43.66 \times 1 \text{ mm/m} \times D$

4.3.4 Protection against interference from systems in close proximity to each other

Overview

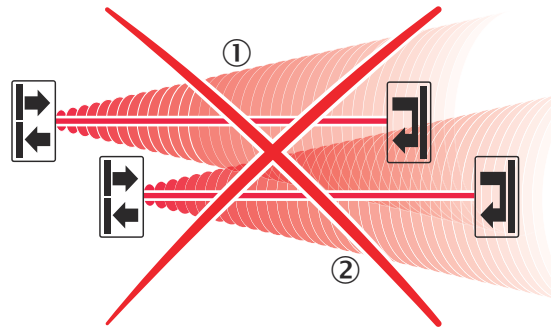

Figure 11: Upset condition 1: Preventing mutual interference from system ① and system ②

Upset condition 1: The infrared light beams of the active unit of system ① can be reflected by the passive unit of system ② and received by the active unit of system ②. This can disrupt the protective function of the systems. This would mean that the operator is at risk.

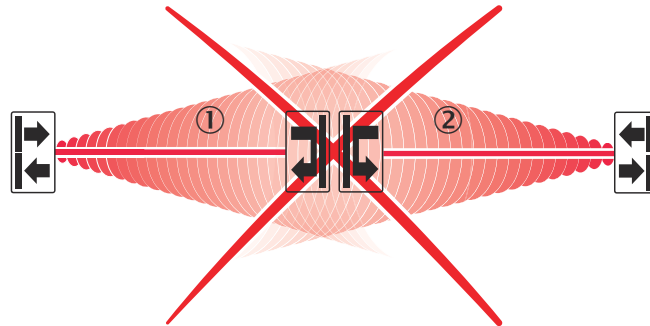

Figure 12: Upset condition 2: Preventing mutual interference from system ① and system ②

Upset condition 2: The infrared light beams of the active units of systems ① and ② can cause mutual interference. This can disrupt the protective function of the systems. This would mean that the operator is at risk.

Important information



DANGER

Hazard due to lack of effectiveness of the protective device

Systems of safety multibeam sensor in close proximity to each other can mutually interfere with each other.

- Use suitable measures to prevent interference between systems in close proximity to each other.

Measures

The following measures prevent interference from systems in close proximity

- Reversed direction of transmission for neighboring systems
- Optically opaque partitions

Complementary information

The active unit works with Uncoded beam coding.

4.3.4.1 Using reversed direction of transmission

An opposite transmission direction prevents mutual interference between adjacent systems.

- ▶ Align the active units of both systems back to back.

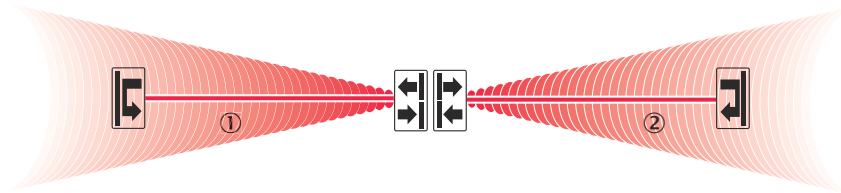

Figure 13: Interference-free operation due to an opposite transmission direction of adjacent systems

In the figure, the transmission direction of systems in close proximity to each other is different. This means system ② is not affected by the beams of system ①.

4.4 Integration in the electrical control system

Requirements for use

The output signals of the protective device must be analyzed by downstream controllers in such a way that the dangerous state of the machine is ended safely. Depending on the safety concept, signal evaluation is carried out e.g. with safety relays or with a safety controller.

- It must be possible to electrically influence the control of the machine.
- The electrical control of the machine must meet the requirements of IEC 60204-1.
- A restart interlock must be implemented depending on applicable national regulations or required reliability of the safety function. Because the protective device does not have an integrated restart interlock, this must be implemented in the external control, if required.
- When using a safety controller, different signal levels of both OSSDs must be detected depending on applicable national regulations or required reliability of the safety function. The maximum discrepancy time tolerated by the controller must be selected according to the application
- The OSSD1 and OSSD2 output signals must not be connected to each other.
- In the machine controller, the signals of both OSSDs must be processed separately.

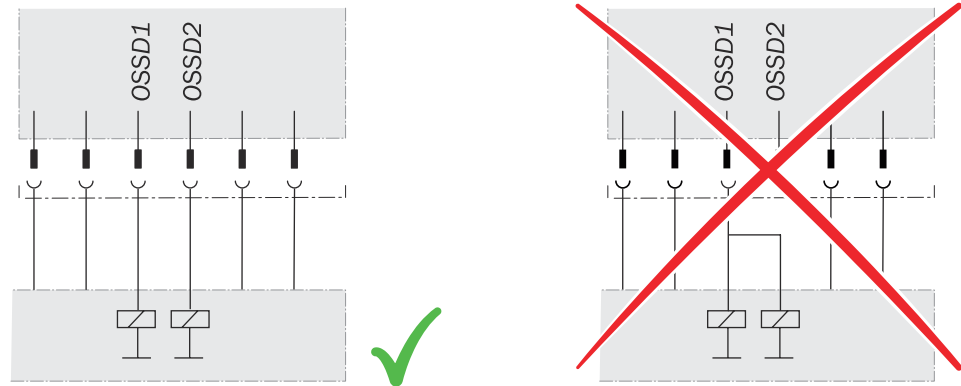

Figure 14: Dual-channel and isolated connection of OSSD1 and OSSD2

- The machine must switch to the safe state at any time if at least one of the two OSSDs switches to the OFF state
- Prevent the formation of a potential difference between the load and the protective device. If you connect loads to the OSSDs (switch outputs) that then also switch if controlled with negative voltage (e.g., electro-mechanical contactor without reverse polarity protection diode), you must connect the 0 V connections of these loads and those of the corresponding protective device individually and directly to the same 0 V terminal strip. In the event of a fault, this is the only way to ensure that there can be no potential difference between the 0 V connections of the loads and those of the corresponding protective device.

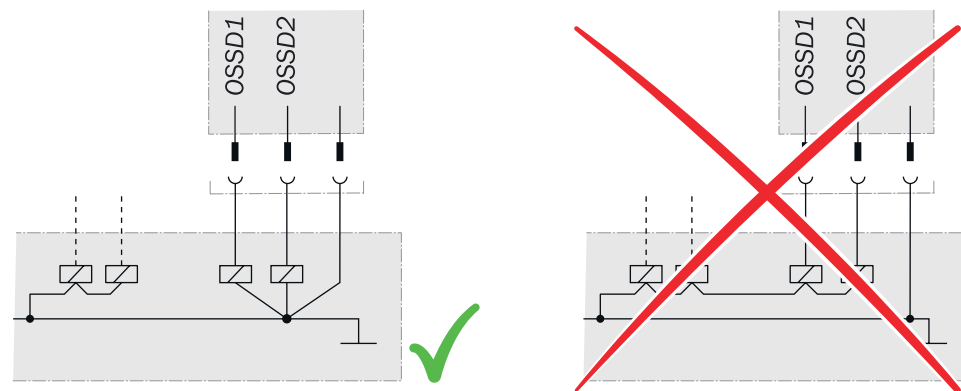

Figure 15: No potential difference between load and protective device



DANGER

Hazard due to lack of effectiveness of the protective device

In the case of non-compliance, it is possible that the dangerous state of the machine may not be stopped or not stopped in a timely manner.

Downstream contactors must be positively guided and monitored depending on applicable national regulations or required reliability of the safety function.

- Make sure that downstream contactors are monitored (external device monitoring, EDM).

Requirements for the electrical control of the machine

Both outputs are short-circuit protected to 24 V DC and 0 V. When the light path is clear, the OSSDs are in the ON state. When a switch-off condition is present (e.g., interruption in the light path), the OSSDs are in the OFF state. In the event of a device fault, at least one OSSD is in the OFF state.

The protective device complies with the rules for electromagnetic compatibility (EMC) for the industrial sector (Radio Safety Class A).



NOTE

Using the device in residential areas may cause radio interference. The operating entity is responsible for taking appropriate measures (e.g., shielding).

The following requirements are met:

- The external voltage supply of the protective device must be capable of buffering brief power failures of 20 ms as specified in IEC 60204-1.
- The power supply unit must ensure safe isolation according to IEC 61140 (SELV/PELV). Suitable power supply units are available as accessories from SICK.

4.4.1 Restart interlock

Overview

The restart interlock prevents the machine from automatically starting up, for example after a protective device has responded while the machine is operating or after changing the machine's operating mode.

Depending on the regulations which apply at the place of installation, a restart interlock may be required.

The protective device does not have an internal restart interlock. You must therefore implement a restart interlock externally via the circuitry or the control if needed, e.g. in connection with the SICK RLY3-OSSD2 / RLY3-OSSD3 safety relay.

Functionality

Before the machine can be restarted, the operator must reset the restart interlock.

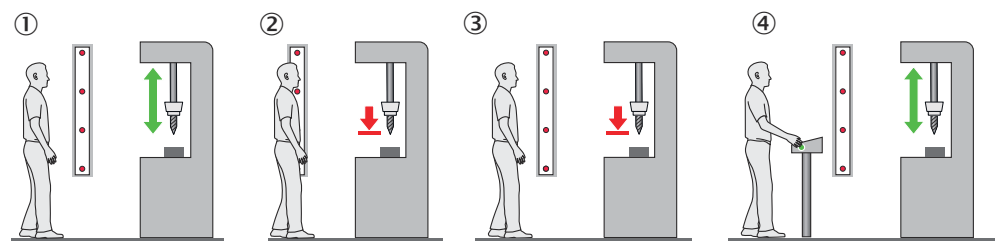

Figure 16: Schematic representation of operation with restart interlock

The dangerous state of the machine (①) is brought to an end if the light path is interrupted (②) and is not re-enabled (③) until the operator presses the reset pushbutton located outside the hazardous area (④). The machine can then be restarted.

Depending on applicable national regulations, a restart interlock must be available if it is possible to stand behind the protective device. Observe IEC 60204-1.

4.4.2 External device monitoring (EDM)

Overview

The external device monitoring (EDM) monitors the status of downstream contactors.

The safety multibeam scanner has no internal external device monitoring.

The external switching elements (external device monitoring, EDM) must be inspected in line with the regulations which apply at the place of installation or the required reliability of the safety function.

Important information



NOTE

Because the protective device does not have integrated external device monitoring, this must be implemented in the external control, if required.

Prerequisites

- Positively guided contactors are used for shutting down the machine. If the auxiliary contacts of the positively guided contactors are connected to the external device monitoring, the external device monitoring checks whether the contactors drop off when the OSSDs are switched off.

4.4.3 Connection diagrams

5-pin, RLY3-OSSD2 safety relay

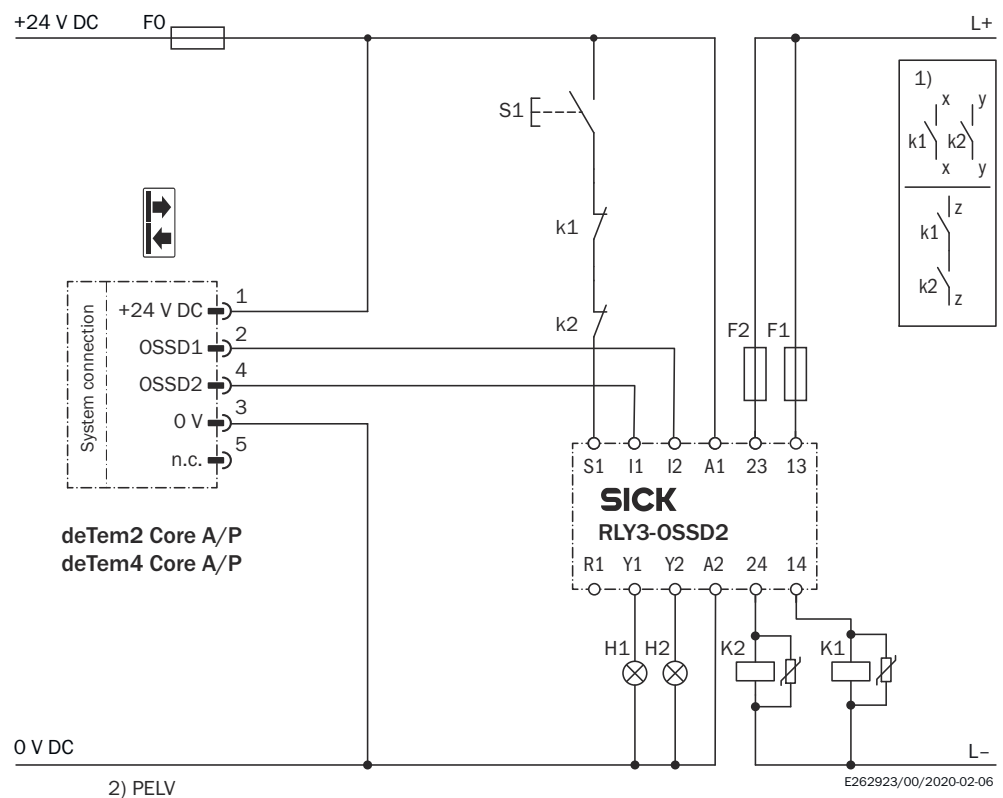

Figure 17: Connection diagram for RLY3-OSSD2 with restart interlock and external device monitoring

- Output circuits: These contacts must be incorporated into the control such that the dangerous state is brought to an end if the output circuit is open. For categories 4 and 3, they must be incorporated on dual-channels (x, y paths). Type 2 devices are suitable for use up to PL c. Single-channel incorporation into the control (z path) is only possible with a single-channel control and taking the risk analysis into account.
- SELV/PELV safety extra-low voltage.

Task

Connection of a deTem4 Core A/P safety multibeam sensor to a RLY3-OSSD2 safety relay. Operating mode: With restart interlock and external device monitoring.

- **Mode of operation**

When the light path is clear, the OSSD1 and OSSD2 outputs carry voltage. The system can be switched on when K1 and K2 are in a fault-free de-energized position. Lamp H2 flashes. The RLY3-OSSD2 is switched on by pressing S1 (pushbutton is pressed and released). The outputs (contacts 13-14 and 23-24) switch the K1 and K2 contactors on. When the light path is interrupted, the OSSD1 and OSSD2 outputs switch the RLY3-OSSD2 off. Lamp H1 lights up. Contactors K1 and K2 are switched off. As soon as the light path is clear again, lamp H2 flashes.

- **Fault analysis**

Cross-circuits and short-circuits of the OSSDs are recognized and lead to the locking status (lock-out). A malfunction with one of the K1 or K2 contactors is detected. The switch-off function is retained. In the event of manipulation (e.g., jamming) of the S1 pushbutton, the RLY3-OSSD2 will not re-enable the output current circuits.

4.5 Testing plan

The manufacturer of the machine and the operating entity must define all required thorough checks. The definition must be based on the application conditions and the risk assessment and must be documented in a traceable manner.

- ▶ When defining the thorough check, please note the following:
 - Define the type and execution of the thorough check.
 - Define the frequency of the thorough check.
 - Notify the machine operators of the thorough check and instruct them accordingly.

The following thorough checks are often defined in connection with a protective device:

- Thorough check during commissioning and modifications
- Regular thorough check

Thorough check during commissioning and modifications

Before commissioning the machine and after making changes, you must check whether the safety functions are fulfilling their planned purpose and whether persons are being adequately protected.

The following points are often helpful for the definition of the thorough check:

- Does the thorough check have to be completed by qualified safety personnel?
 - Can the thorough check be completed by personnel specially qualified and authorized to do so?
 - Does the thorough check have to be documented in a traceable manner?
 - Can the check be carried out according to a check list? (see ["Checklist for initial commissioning and commissioning"](#), page 75)
 - Do the machine operators know the function of the protective device?
 - Have the machine operators been trained to work on the machine?
 - Have the machine operators been notified about modifications to the machine?
 - Does the hazardous area being secured have to be checked with a test rod? (see ["Test rod check"](#), page 27)
- ▶ Define all guidelines for the thorough check.

Regular thorough check

The thorough check is intended to ensure that the safety functions are fulfilling their planned purpose and whether persons are being adequately protected.

The following points are often helpful for the definition of the thorough check:

- Which thorough check must be carried out and how is it carried out?
 - "Test rod check", page 27
 - "Visual check of the machine and the protective device", page 28
 - How often does the thorough check have to be carried out?
 - Do the machine operators have to be notified of the thorough check and do they need to be instructed accordingly?
- ▶ Define all guidelines for the thorough check.

4.5.1 Test rod check

Overview

The light beam is covered with an opaque test rod (diameter of 30 mm).

When the light beam is covered, the OSSD LED on the active unit must light up red.

The test rod check is carried out with an outstretched arm for each light beam and at multiple positions between the active and passive units.

Important information



DANGER

Hazard due to unexpected starting of the machine

- ▶ Make sure that the dangerous state of the machine is and remains switched off during the check.
- ▶ Make sure that the outputs of the safety multibeam sensor do not affect the machine during the thorough check.



DANGER

Hazard due to lack of effectiveness of the protective device

Persons and parts of the body to be protected may not be recognized in case of non-observance.

Do not operate the machine if the OSSD LED lights up green during the test!

- ▶ If the OSSD LED lights up green during the test, even if only briefly, work must stop at the machine.
- ▶ In this case, the mounting and electrical installation of the safety multibeam sensor must be checked by appropriately qualified safety personnel.

Prerequisites

- The OSSD LED lights up green.

Approach

1. Cover a light beam completely.
Hold the test rod with an outstretched arm.

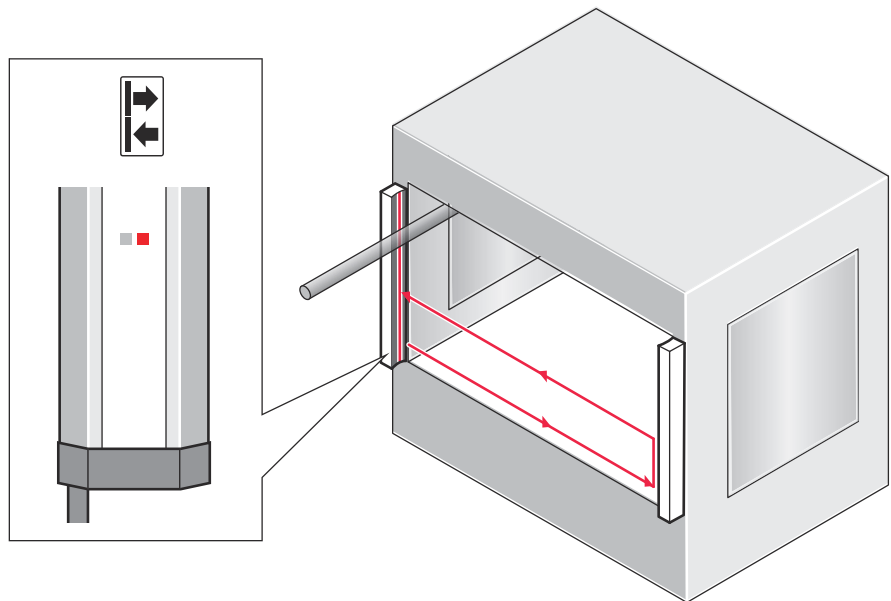

- ✓ The OSSD LED on the active unit lights up red.
- 2. Enable the light beam.

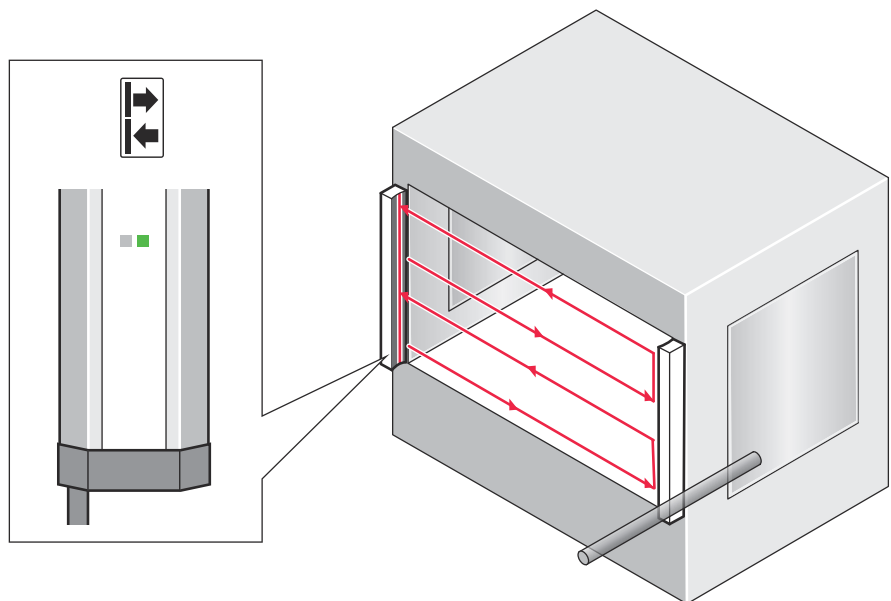

- ✓ The OSSD LED on the active unit lights up green.
- 3. Carry out the test rod check for each light beam.
- 4. Carry out the test rod check at the following positions:
 - Directly in front of the active unit
 - In the middle between active unit and passive unit
 - Immediately in front of the passive unit

4.5.2 Visual check of the machine and the protective device

The following points are often helpful for the definition of the check:

- Has the machine been retrofitted?
- Have machine parts been removed?
- Have modifications been made to the surroundings of the machine?
- Have the protective device or its parts been dismantled?
- Is it possible to enter the hazardous area without being detected?
- Is the protective device damaged?

- Is the protective device severely contaminated?
- Is the front screen contaminated, scratched or destroyed?
- Are there any damaged cables or open cable ends?

If one of the points applies, the machine should be shut down immediately. In this case, the machine and the protective device must be checked by appropriately qualified safety personnel.

5 Mounting

5.1 Unpacking

Approach

1. Check the components for completeness and the integrity of all parts.
2. In the event of complaints, contact the responsible SICK subsidiary.

Further topics

- ["Scope of delivery", page 66](#)

5.2 Mounting

Important information



DANGER

Hazard due to lack of effectiveness of the protective device

Persons or parts of the body to be protected may not be recognized or not recognized in time in case of non-observance.

- ▶ Take account of the minimum distances calculated for the machine: see ["Minimum distance from the hazardous point", page 17](#), see ["Minimum distance from reflective surfaces", page 19](#).
- ▶ Mount the protective device such that nobody can pass under the lowest light beam, pass over the highest light beam, get between two light beams, or pass by the side of the protective device.

Prerequisites

- Project planning is completed.
- Assembly is carried out according to the project planning.
- Dangerous condition of the machine is and remains switched off during mounting.
- The outputs of the device do not affect the machine during mounting.
- Only use SICK-approved brackets for mounting.
- Take appropriate measures for vibration damping if vibration and shock specifications exceed the values and test conditions specified in the data sheet.

Notes on mounting

- ▶ Mount the active and passive units on a level surface (①).

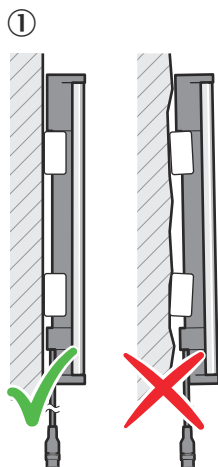

- ▶ Align the active and passive units at right angles to one another. The optics systems must be opposite one another (②).
 - With passive unit for small scanning ranges: Mount the active and passive units at the same height.

②

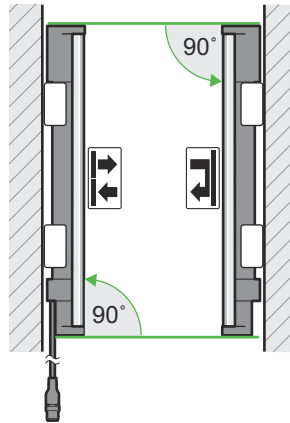

- With passive unit for large scanning ranges: Mount the passive unit offset from the active unit. Consider the distance $A = 71.8 \text{ mm}$, see "Dimensional drawings", page 63.

②

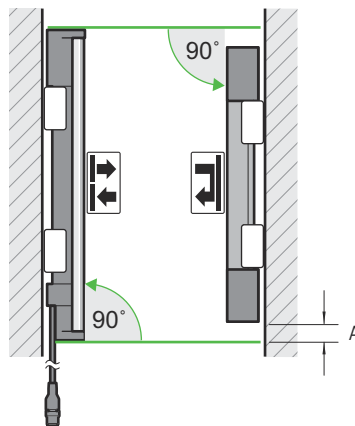

- ▶ When using a QuickFix, FlexFix or Compact FlexFix bracket:
 - For minor adjustments when aligning, the active and passive units can be adjusted longitudinally in the brackets.
 - Position the brackets near the ends of the housing. If the device is exposed to strong vibrations during operation, mount the top bracket at a height where the offset in the safety multibeam scanner housing rests on the bracket (③).

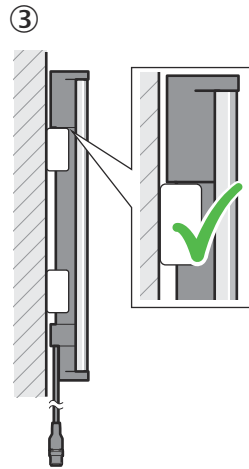

- ▶ Observe the tightening torque details. Higher torques can damage the bracket, while lower torques do not offer sufficient protection against slipping of the active and passive units. (4)

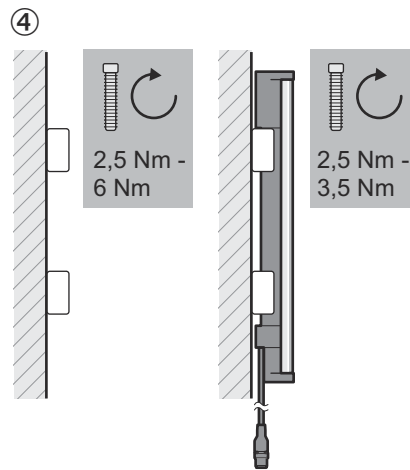
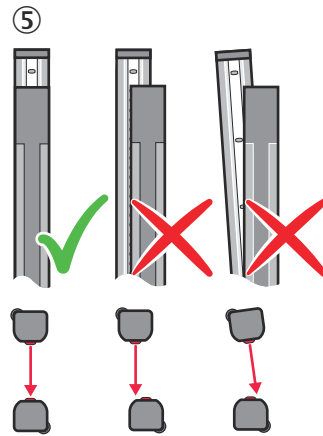

Table 6: Tightening torques depending on the bracket used

	QuickFix / (Compact) FlexFix bracket	Flat mount bracket ¹⁾	Swivel mount bracket ¹⁾
Bracket on the machine or profile frame	5 Nm ... 6 Nm	2.5 Nm ... 3 Nm	4.5 Nm ... 5 Nm
Active and passive units in the bracket	2.5 Nm ... 3 Nm	-	3 Nm ... 3.5 Nm

¹⁾ Can only be used on the active unit and passive unit for short scanning ranges.

- ▶ Make sure that the active and passive units are aligned correctly. The optics systems of the active and passive units must be opposite one another (5).



- If necessary, use a spirit level to check that the components are parallel (⑥).

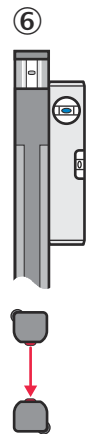

5.2.1 Mounting the QuickFix bracket

Overview

The active and passive units are each mounted using 2 QuickFix brackets.

The QuickFix bracket consists of 2 individual parts that are pushed into each other. The two individual parts are connected using an M5 screw, and the housings of the active and passive units are clamped with form-fit clamping.

The two mounting surfaces for the brackets of the active and passive units must be parallel and lie on the same plane.

Important information



NOTE

The following should be considered when mounting the QuickFix bracket:

- Select the appropriate length of the M5 screw to prevent any risk of injury from an overrun
- When selecting the screw length, observe the wall thickness and the depth of the countersunk screw of the QuickFix bracket, [see figure 33, page 68](#)



NOTE

The QuickFix bracket has a cable guide. Depending on the installation, the cable guide can make mounting easier.

Mounting the QuickFix bracket on a machine or profile frame

Table 7: Side and rear mounting with the QuickFix bracket

Mounting method	Description
On the side	Fasten the M5 screw to the machine or profile frame through the QuickFix bracket. A screw nut or threaded hole is required on the machine or profile frame (①).
	Fasten the M5 screw to the QuickFix bracket through the machine or profile frame. A screw nut is required for each QuickFix bracket (②).
	Fasten the M5 screw to the profile frame through the QuickFix bracket. A sliding nut is required on the profile frame (③).
On the back	Fasten the M5 screw to the machine or profile frame through the QuickFix bracket. A screw nut or threaded hole is required on the machine or profile frame (④).

Tightening torque: 5 Nm ... 6 Nm

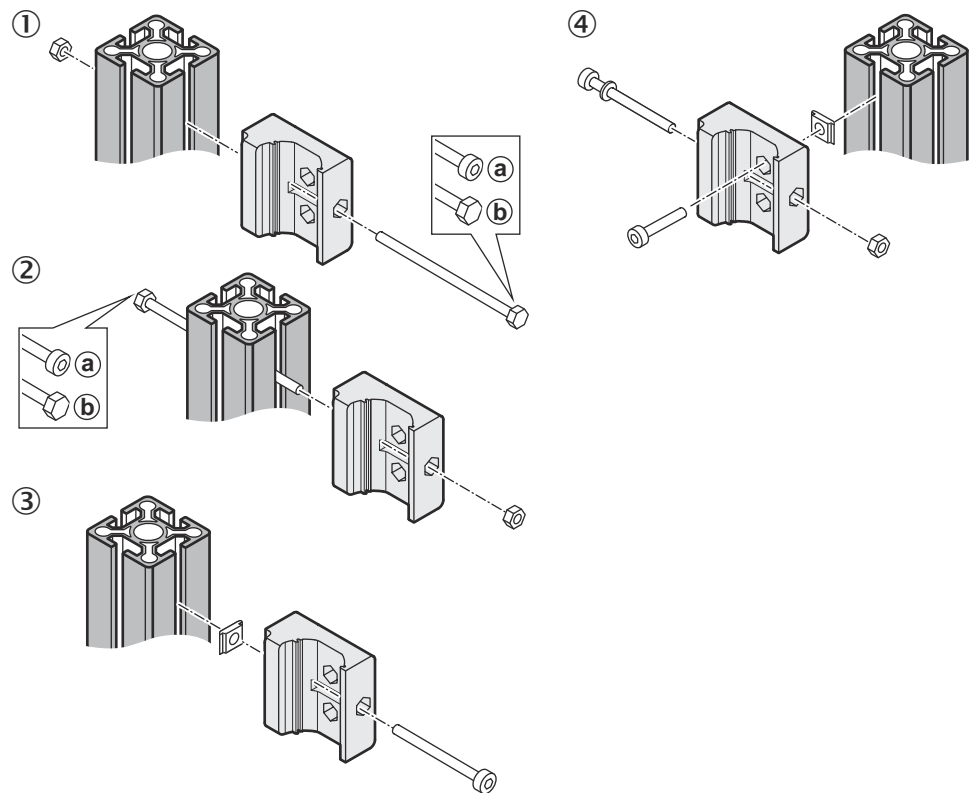

Figure 18: Mounting the QuickFix bracket on a profile

Secure the active and passive unit in the bracket

1. Insert the housing of the active and passive unit into the bracket so that it fits snugly.
2. Secure the position of the active and passive unit in the bracket using the M5 screw.
Torque: 2.5 Nm to 3 Nm

5.2.2 Mounting the FlexFix bracket

Overview

In the FlexFix bracket, the active and passive units can be rotated $\pm 15^\circ$ around their longitudinal axis.

The active and passive units are each mounted using 2 FlexFix brackets.

As a rule, each FlexFix bracket is mounted to the mounting surface with 2 screws. In exceptional cases (e.g. reduced vibration and shock requirements), a FlexFix bracket can be mounted with only one screw if this does not impair the function.

Important information



NOTICE

The housing of the safety multibeam sensor can become scratched if the screw heads protrude when the FlexFix brackets are mounted on the back.

Avoid this by taking one of the following measures:

- ▶ Use flat head screws.
- ▶ If using cylinder head screws, use two screws per bracket and no washers.



NOTE

The FlexFix mounting kit (part number 2073543) contains 2 FlexFix brackets, one alignment tool, and the required screws, sliding nuts, and washers.

Further topics

- ["Brackets", page 67](#)

5.2.2.1 Mounting the FlexFix bracket on a machine or profile frame

Mounting the FlexFix bracket on a machine or profile frame

Table 8: Lateral and rear mounting with the FlexFix bracket

Mounting method	Description
On the side	With the M5 screw through the FlexFix bracket on the machine or profile frame. A screw nut or threaded hole is required on the machine or profile frame (①).
	With the M5 screw through the FlexFix bracket on the profile frame. 2 sliding nuts are required on the profile frame (②).
On the back	With the M5 screw through the FlexFix bracket on the machine or profile frame. A screw nut or threaded hole is required on the machine or profile frame (③).

Tightening torque: 5 Nm ... 6 Nm

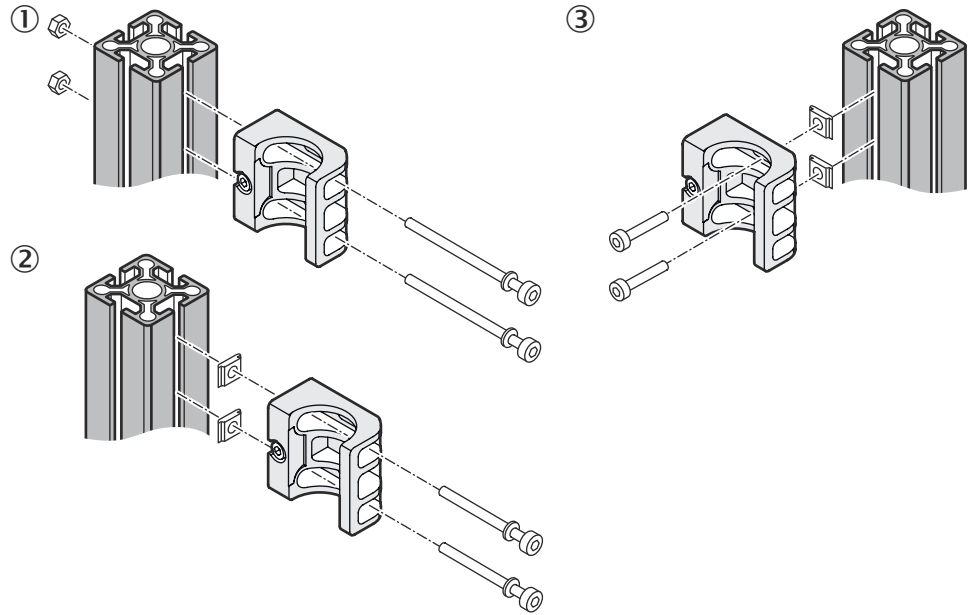

Figure 19: Mount FlexFix bracket to a profile frame

Secure the active and passive unit in the bracket

1. After mounting the brackets, screw the active and passive units into the brackets from the front. (①)
 2. Align the active and passive units.(②)
 3. Use an M5 screw to secure the position of the active and passive unit in the bracket.(③)
- Torque: 2.5 Nm to 3 Nm

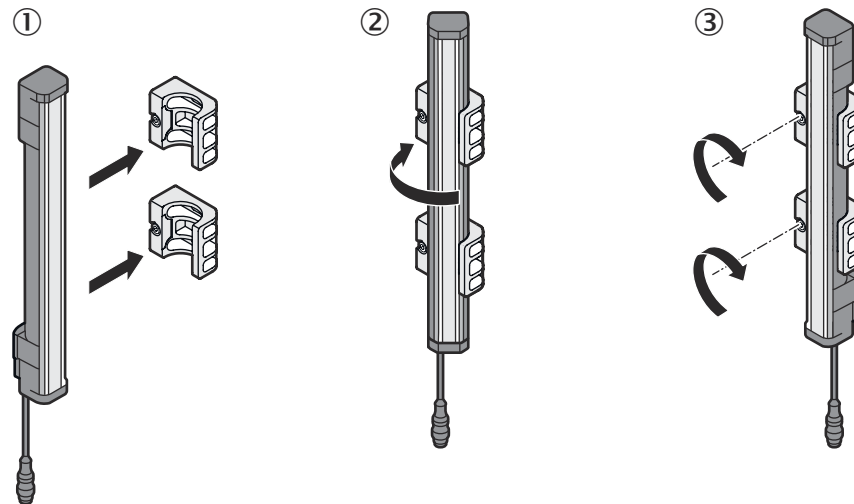

Figure 20: Inserting the protective device in the FlexFix brackets



NOTE

The protective device can only be screwed in when both brackets are in alignment.

Recommendation:

1. Only hand-tighten the screws on the brackets at first.
2. Align the two brackets. To do this, place a straightedge or spirit level, for example, on the screw mounting surfaces of the brackets that are not being used.
3. Tighten the screws.

Further topics

- ["Alignment of the active and passive units", page 45](#)

5.2.2.2 Mounting the FlexFix bracket on the back of a device column**Overview**

The FlexFix bracket can be mounted in the device column using sliding nuts.

If you wish to mount the active and passive units each in the center of the device column, use alignment plates between the FlexFix brackets and the device column.

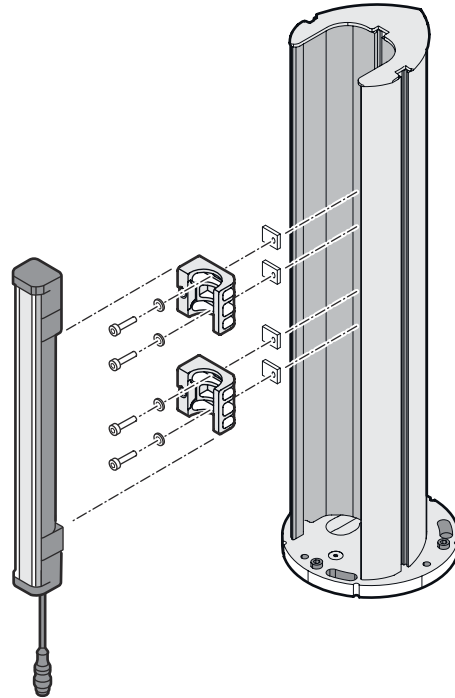

Figure 21: Mounting the FlexFix bracket on a device column (accessory)

Secure the active and passive unit in the bracket

1. After mounting the brackets, screw the active and passive units into the brackets from the front.
2. Align the active and passive units.
3. Use an M5 screw to secure the position of the active and passive unit in the bracket.
Torque: 2.5 Nm to 3 Nm

Further topics

- ["Alignment of the active and passive units", page 45](#)

5.2.3 Mounting optional Compact FlexFix bracket**Overview**

With a Compact FlexFix bracket, you can mount the active and passive units closer to the machine or profile frame.

The active and passive units are each mounted using 2 Compact FlexFix brackets.

In the Compact FlexFix bracket, the active and passive units can be rotated $\pm 15^\circ$ around their longitudinal axis.

Important information**NOTICE**

The housing of the active and passive unit can become scratched if the screw heads protrude when the Compact FlexFix brackets are mounted on the back.

This can be avoided by taking the following measure:

- ▶ Use countersunk screws without washer.

Mounting the Compact FlexFix bracket on a machine or profile frame

Table 9: Side and rear mounting of the Compact FlexFix bracket on a machine or profile frame

Mounting method	Description
On the side	With the M5 screw through the Compact FlexFix bracket on the machine or profile frame. A screw nut or threaded hole is required on the machine or profile frame (①).
	With the M5 screw through the Compact FlexFix bracket on the profile frame. 2 sliding nuts are required on the profile frame (②).
On the back	With the M5 countersunk screw through the Compact FlexFix bracket on the machine or profile frame. A screw nut or threaded hole is required on the machine or profile frame (③).

Tightening torque: 5 Nm ... 6 Nm

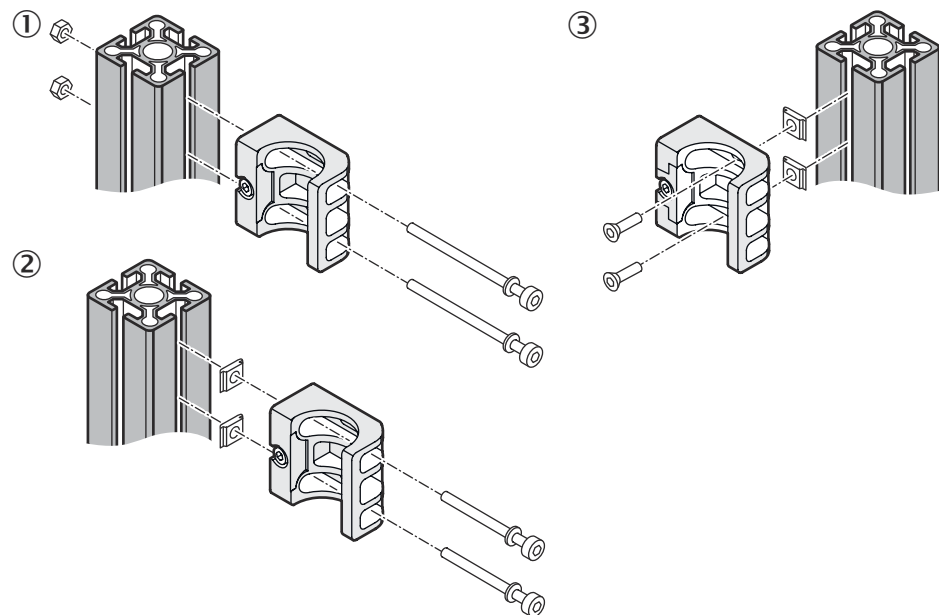

Figure 22: Mount the Compact FlexFix bracket on a profile frame

Secure the active and passive unit in the bracket

1. After mounting the brackets, screw the active and passive units into the brackets from the front. (①)
2. Align the active and passive units. (②)

**NOTE**

The protective device can only be screwed in when both brackets are in alignment.

Recommendation:

1. Only hand-tighten the screws on the brackets at first.
 2. Align the two brackets. To do this, place a straightedge or spirit level, for example, on the screw mounting surfaces of the brackets that are not being used.
 3. Tighten the screws.
-
3. Use an M5 screw to secure the position of the active and passive unit in the bracket. (③)
Torque: 2.5 Nm to 3 Nm

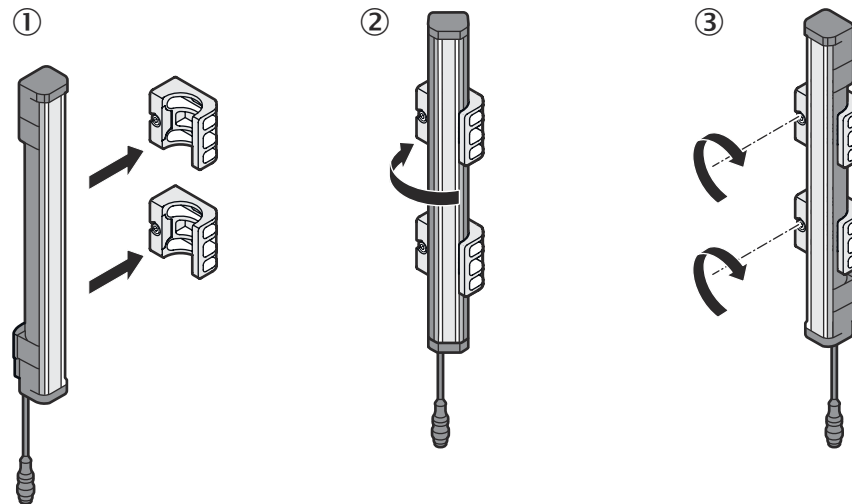

Figure 23: Inserting the protective device in the Compact FlexFix brackets

5.2.4 Mounting flat mount bracket

Overview

You can use the flat mount bracket on the active unit and passive unit for short scanning ranges.

The active unit and passive unit for short scanning ranges are each mounted using 2 flat mount brackets.

Approach

1. Slide the bracket onto the end cap of the device. (①)

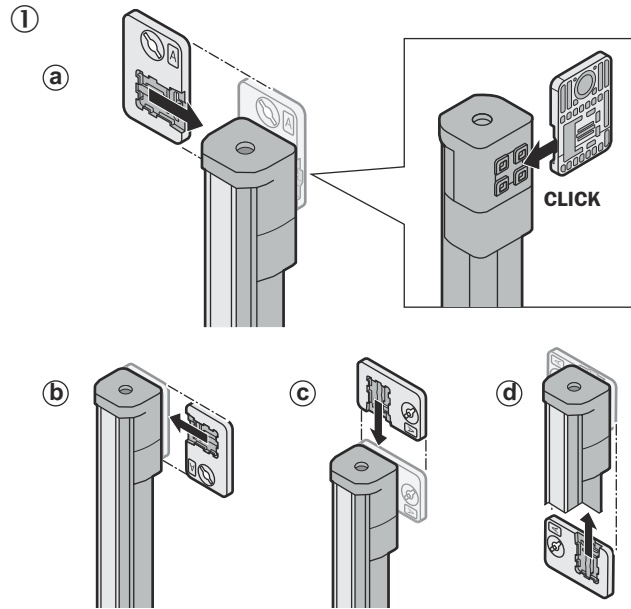

The bracket can be aligned horizontally or vertically. (options a - d)
 A clicking sound can be heard when the bracket is firmly seated on the end cap of the device.



NOTE

If the bracket is mounted concealed on the device (option b), observe the following:

- Use a suitable tool (e.g. slotted screwdriver) to turn the insert out of the fixing hole of the bracket.
- Mount the bracket to the machine or profile frame using an M6 countersunk screw. Then slide the device onto the bracket.

2. Mount the bracket with an M5 screw to a machine or profile frame. (2)

(2)

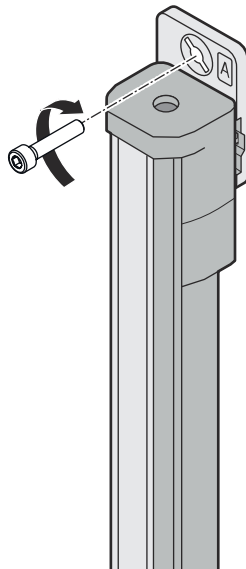

Torque: 2.5 Nm to 3 Nm

- ✓ The device is firmly mounted in the bracket.

Complementary information

Information on disassembly, see ["Mounting swivel mount bracket"](#), page 41.

5.2.5 Mounting swivel mount bracket

Overview

You can use the swivel mount bracket on the active unit and passive unit for short scanning ranges.

The active unit and passive unit for short scanning ranges are each mounted using 2 swivel mount brackets.

The swivel mount bracket consists of 2 individual parts, a swivel mount adapter and a swivel mount port.

Approach

1. Slide the swivel mount adapter onto the end cap of the device. (①)

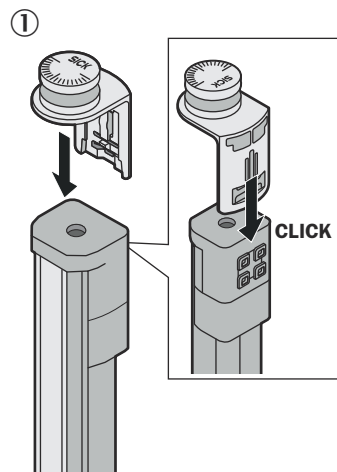

2. Attach the swivel mount port to the adapter. (②)

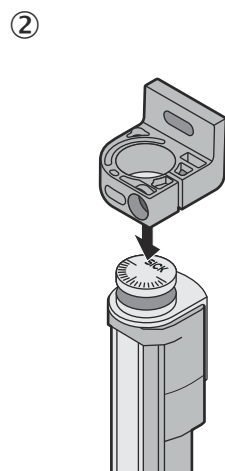

3. Loosely screw in the M5 screw to mount the two individual parts. (③)

③

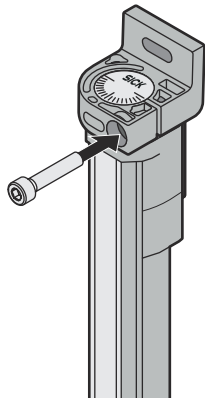

4. Using an M5 screw, mount the swivel mount bracket to a machine or profile frame through the mounting hole. (④)

④

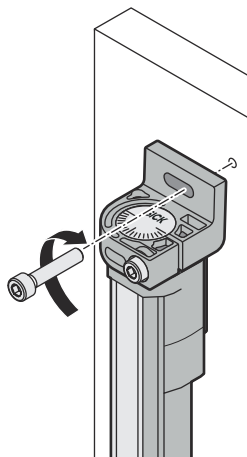

Torque: 4.5 Nm to 5 Nm

5. Align the device in the bracket. (⑤)

⑤

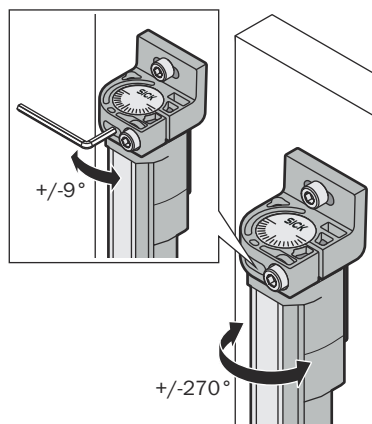

The device can be rotated up to $\pm 270^\circ$ in the bracket. Fine adjustment is possible as an option via the slot on the front of the bracket. To do so, insert a hexagon key into the slot and align the device by up to $\pm 9^\circ$.

6. When the device is correctly aligned, tighten the M5 screw to mount the two individual parts. (⑥)

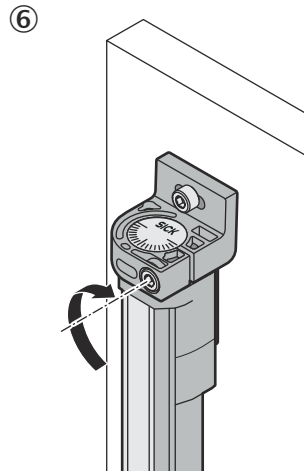

Torque: 3 Nm to 3.5 Nm

- ✓ The device is firmly mounted in the bracket.

Removal

Using a suitable tool (e.g., slotted screwdriver), press on the circlip of the bracket (①) and pull the bracket off the device using a rotating movement (②).

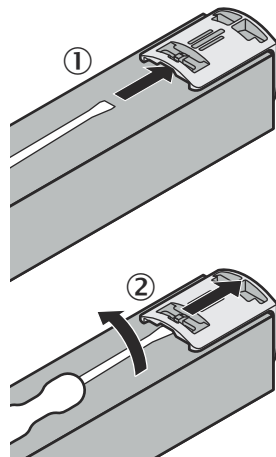

5.2.6 Mounting the replacement bracket

Overview

If an existing safety multibeam scanner is mounted with a swivel mount bracket or a side bracket, it can be replaced by a deTem4 Core A/P safety multibeam scanner using a replacement bracket. There is no need to drill new holes, since the existing ones can be used for the replacement bracket.

Complementary information

Detailed information for mounting a safety multibeam scanner with a replacement bracket can be found in the mounting instructions for the replacement bracket.

6 Electrical installation

6.1 Connecting

Prerequisites

- Mounting is completed.
- Electrical installation is carried out according to the project planning.
- Dangerous condition of the machine is and remains off during the electrical installation.
- Outputs of the device have no effect on the machine during electrical installation.
- Connect the two OSSDs separately.
- Connect the OSSDs such that the machine controller can process both signals separately.
- Avoiding any potential difference between load and device.

Further topics

- ["Project planning", Seite 16](#)
- ["Mounting", Seite 30](#)

6.1.1 System connection (M12, 5-pin)

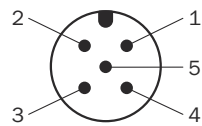

Figure 24: System connection (male connector, M12, 5-pin)

Table 10: System connection pin assignment (male connector, M12, 5-pin)

Pin	Wire color ¹⁾	Active unit
1	Brown	+24 V DC (voltage supply input)
2	White	OSSD1 (switching output 1)
3	Blue	0 V DC (voltage supply input)
4	Black	OSSD2 (switching output 2)
5	Gray	Not assigned

¹⁾ Applies to the connecting cables recommended as accessories.

7 Commissioning

7.1 Overview

Prerequisites

- Project planning is completed.
- Mounting is completed.
- Electrical installation is completed.
- Dangerous state of the machine is and remains off during commissioning.
- The outputs of the device do not affect the machine during commissioning.
- The machine has been inspected and released by qualified safety personnel.
- Protective device works properly.
- The protection function is checked after each change to the machine or to the integration or the operating and boundary conditions of the device.

Further topics

- ["Design", page 16](#)
- ["Integration in the electrical control system", page 22](#)
- ["Mounting", page 30](#)
- ["Electrical installation", page 44](#)

7.2 Switching on

After the protective device is switched on, the OSSD LED, the ERR LED and the diagnostic LEDs light up briefly.

After initialization, the blue diagnostic LEDs indicate the alignment quality.

- In a system with 2 beams, the alignment quality is indicated via the diagnostic LEDs 1 ... 4.
- In a system with 4 beams, the alignment quality of the beams close to the system connection is indicated via the diagnostic LEDs 1 ... 4 and the alignment quality of the beams far from the system connection via the diagnostic LEDs 5 ... 8.

If front screen contamination increases in ongoing operation or the alignment is poor for longer than 3 seconds, the active unit shows the alignment quality again.

Once the protective device is aligned (OSSD LED: green), the alignment display switches off after a certain period of time, and only the OSSD LED continues to light up.

In the event of a fault, the red ERR LED flashes. In combination with the diagnostic LEDs, the ERR LED indicates the cause of the error, [see "Troubleshooting", page 56](#).

7.3 Alignment of the active and passive units

Overview

Once mounting and electrical installation are complete, the active and passive units must be aligned with each other.

Important information



DANGER

Dangerous state of the machine

- ▶ Make sure that the dangerous state of the machine is (and remains) switched off during the alignment process.
- ▶ Make sure that the outputs of the safety multibeam sensor do not affect the machine during the alignment process.

Further topics

- ["Alignment with the QuickFix bracket", page 46](#)
- ["Alignment with the FlexFix bracket or with the replacement bracket", page 47](#)
- ["Indication of the alignment quality", page 50](#)

7.3.1 Aligning the active and passive units

Prerequisites

- Active and passive units have been mounted correctly
- The light path is free of objects. Neither objects nor body parts (e.g. hand, tool, optional AR60 laser alignment aid) are in the light path.

Approach

1. Ensure that the active and passive units can rotate in the brackets. If necessary, loosen the fixing screws slightly.
2. Switch on the voltage supply to the active unit.
3. Roughly align the active unit with the passive unit: Turn the active unit so that it is pointing toward the passive unit.
4. Align the passive unit with the active unit: Turn the passive unit so that as many blue diagnostic LEDs as possible light up on the active unit.
5. If necessary, align the active unit more precisely with the passive unit so that as many diagnostic LEDs as possible light up on the active unit.
6. If necessary, align the passive unit more precisely with the active unit so that as many diagnostic LEDs as possible light up on the active unit.
7. In a system with 2 light beams: If at least 3 (better: 4) of diagnostic LEDs 1 ... 4 light up on the active unit, fix the components in the brackets. Torque: 2.5 Nm ... 3 Nm.
8. In a system with 4 light beams: If at least 3 (better: 4) of the diagnostic LEDs 1 ... 4 and at least 3 (better: 4) of diagnostic LEDs 5 ... 8 light up on the active unit, fix the components in the brackets. Torque: 2.5 Nm ... 3 Nm.
9. Switch the voltage supply off and back on again.
10. Check the diagnostic LEDs for the alignment quality to make sure that the components are still correctly aligned with each other.

Complementary information

The optional AR60 laser alignment aid can make alignment even easier. It can be mounted on the active unit and on the passive unit for small scanning ranges. To ensure that the display of the alignment quality cannot be impaired, place the AR60 optional laser alignment aid with the adapter between the light beams of the safety multibeam sensor.

7.3.2 Alignment with the QuickFix bracket

Prerequisites

- The active and passive units are each mounted using a QuickFix bracket

Alignment with the QuickFix bracket

The QuickFix bracket offers you the following options for aligning the active and passive units with each other:

- Vertical adjustment (H)

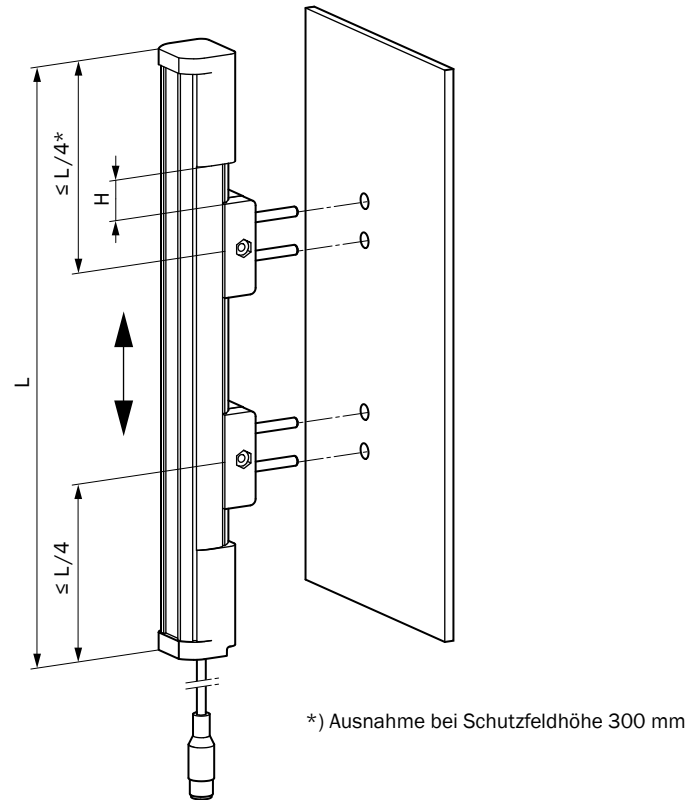

Figure 25: QuickFix bracket: Vertical adjustment

7.3.3 Alignment with the FlexFix bracket or with the replacement bracket

Prerequisites

- A FlexFix bracket or replacement bracket has been used to mount each active and passive unit

Alignment with the FlexFix bracket or with the replacement bracket

The FlexFix bracket or replacement bracket offer you the following adjustment options for aligning the active and passive units with each other:

- Vertical adjustment (H)

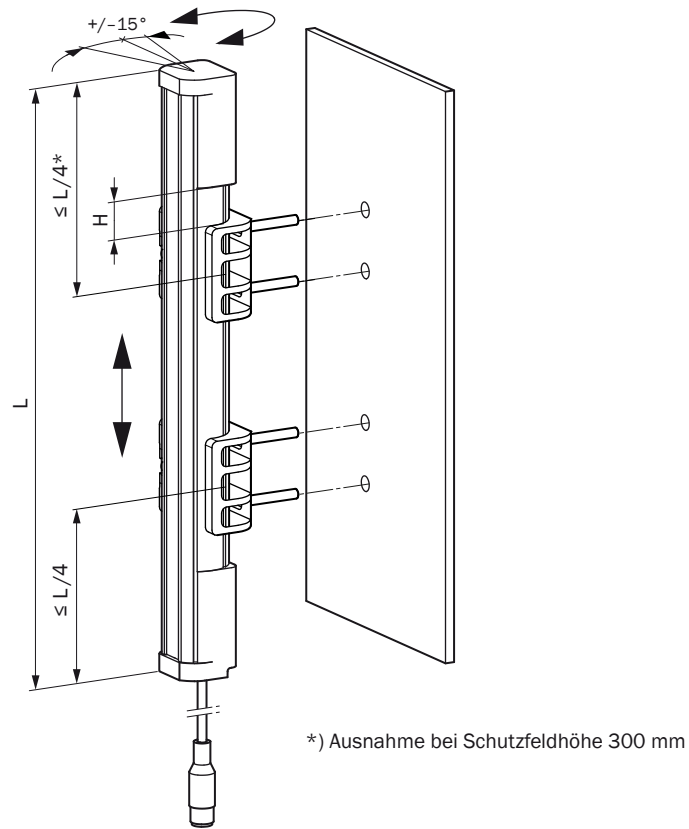

Figure 26: FlexFix bracket: Vertical adjustment / rotation

7.3.4 Alignment with the Compact FlexFix bracket

Prerequisites

- The active unit and passive unit for short scanning ranges are mounted using a Compact FlexFix bracket

Alignment with the Compact FlexFix bracket

The Compact FlexFix bracket offers you the following adjustment options for aligning the active unit and passive unit for short scanning ranges with each other:

- Shift vertically
- Rotation ($\pm 15^\circ$)

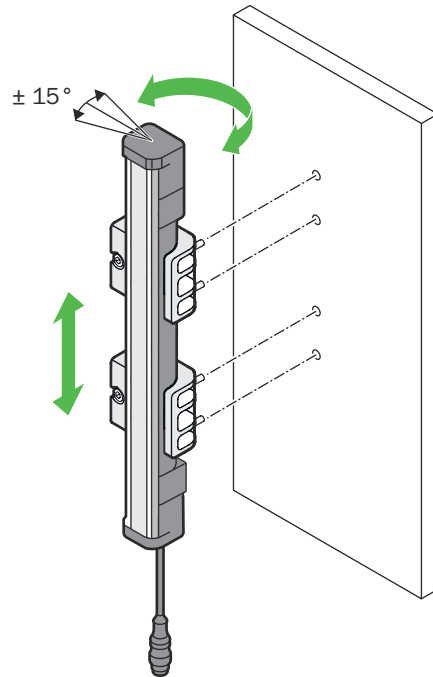

Figure 27: Compact FlexFix bracket: Rotate

7.3.5 Alignment with the swivel mount bracket

Prerequisites

- The active unit and passive unit for short scanning ranges are mounted using a swivel mount bracket

Alignment with the swivel mount bracket

The swivel mount bracket offers you the following options for aligning the active unit and passive unit for short scanning ranges with each other:

- Turning ($\pm 270^\circ$ or $\pm 9^\circ$)

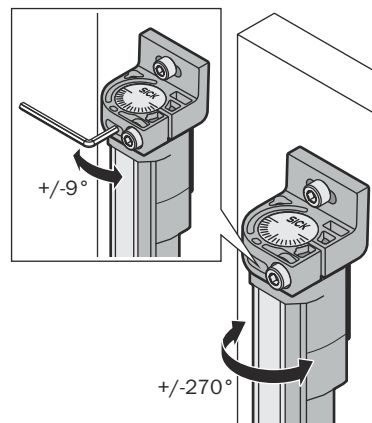

Figure 28: Swivel mount bracket: Rotate

7.3.6 Indication of the alignment quality

Important information



NOTE

As soon as at least 3 (better: 4) of the diagnostic LEDs 1 ... 4 or 5 ... 8 (depending on the number of beams) light up blue, the alignment is good and the availability stable.

Indication of the alignment quality

Table 11: Display of alignment quality (system with 2 beams)

LEDs								Meaning
Diagnostics LEDs								
1	2	3	4	5	6	7	8	
○	○	○	○	○	○	○	○	Alignment is inadequate, or a light beam is at least partially interrupted.
● Blue	● Blue	○	○	○	○	○	○	The alignment or signal strength is still insufficient for stable availability.
● Blue	● Blue	● Blue	○	○	○	○	○	Alignment is good, stable availability. ¹⁾
● Blue	● Blue	● Blue	● Blue	○	○	○	○	Alignment is very good.

○ LED off. ● LED flashes. ● LED illuminates.

¹⁾ If the light path is very long, there is a possibility that diagnostic LED 4 does not light up, even with optimal alignment.

Table 12: Display of alignment quality (system with 4 beams)

LEDs								Meaning
Diagnostics LEDs								
1	2	3	4	5	6	7	8	
○	○	○	○					Alignment of the two light beams close to the system connection is inadequate, or a light beam is at least partially interrupted.
● Blue	● Blue	○	○					The alignment or signal strength of the two light beams close to the system connection is still insufficient for stable availability.
● Blue	● Blue	● Blue	○					The alignment of the two light beams close to the system connection is good, stable availability. ¹⁾
● Blue	● Blue	● Blue	● Blue					The alignment of the two light beams close to the system connection is very good.
				○	○	○	○	Alignment of the two light beams far from the system connection is inadequate, or a light beam is at least partially interrupted.
				● Blue	● Blue	○	○	The alignment or signal strength of the two light beams far from the system connection is still insufficient for stable availability.
				● Blue	● Blue	● Blue	○	The alignment of the two light beams far from the system connection is good, stable availability. ¹⁾
				● Blue	● Blue	● Blue	● Blue	The alignment of the two light beams far from the system connection is very good.

○ LED off. ● LED flashes. ● LED illuminates. Empty cells mean that the LED lights up, flashes, or is off.

¹⁾ If the light path is very long, there is a possibility that diagnostic LED 4 or diagnostic LED 8 does not light up, even with optimal alignment.

Further topics

- "Diagnostic LEDs", page 56

7.4 Check during commissioning and modifications

The thorough check is intended to ensure that the safety functions are fulfilling their planned purpose and whether persons are being adequately protected.

- ▶ Carry out the checks specified in the test plan of the manufacturer of the machine and the operating entity.

8 Operation

8.1 Overview

Information on the status as well as diagnostics and troubleshooting of the protective device can be displayed as follows:

- **Diagnostics LEDs**
Status and fault information, as well as diagnostics data, are displayed directly on the active unit by means of the diagnostics LEDs.
- **NFC**
Status and fault information, as well as diagnostics data, can be read out to an NFC-capable device by means of an integrated NFC interface.

Complementary information

You can find additional information on NFC in the SICK Safety Assistant app.

Further topics

- ["Diagnostic LEDs", page 56](#)

8.2 Regular thorough check

The thorough check is intended to ensure that the safety functions are fulfilling their planned purpose and whether persons are being adequately protected.

- ▶ Carry out the checks specified in the test plan of the manufacturer of the machine and the operating entity.

8.3 LEDs

Active unit

Position of LEDs: [see figure 6, page 14](#)

Table 13: LEDs on the active unit during normal operation

LEDs										Meaning	
ERR	OSSD	Diagnostics LEDs									
		1	2	3	4	5	6	7	8		
○	● Green										The light path is clear.
○	● Red										The light path is interrupted.

○ LED off. ● LED flashes. ● LED illuminates. Empty cells mean that the LED lights up, flashes, or is off.

If front screen contamination increases in ongoing operation or the alignment is poor for longer than 3 seconds, the active unit shows the alignment quality again.

Further topics

- ["Indication of the alignment quality", page 50](#)
- ["Diagnostic LEDs", page 56](#)

9 Maintenance

9.1 Regular cleaning

Overview

Depending on the ambient conditions of the protective device, the front screens must be cleaned regularly and in the event of contamination. Static charges can cause dust particles to be attracted to the front screen.

The weld spark guard must also be cleaned regularly and in the event of contamination.

With increasing contamination, the 2 illuminated diagnostic LEDs 1 and 2 indicate that the active unit is receiving a weak signal from the passive unit. If the device is not cleaned and contamination increases, the protective device switches to the OFF state when contamination is high.

Important information



DANGER

Hazard due to lack of effectiveness of the protective device

Persons and parts of the body to be protected may not be recognized in case of non-observance.

- ▶ Regularly check the degree of contamination on all components based on the application conditions.
 - ▶ Observe the information on the regular rod test check.
-



DANGER

Hazard due to lack of effectiveness of the protective device

Persons and parts of the body to be protected may not be recognized in case of non-observance.

- ▶ Make sure that the optical properties of the front screens of the active and passive units for small scanning ranges are not changed, e.g. by:
 - beading water, mist, frost, or ice formation. If applicable, remove films or other types of contamination, disconnect the voltage supply of the active unit and then switch it back on.
 - Scratches or damage. Replace the device if the front screen is scratched or damaged.
 - ▶ Make sure that all reflective surfaces and objects maintain a minimum distance from the light beams.
 - ▶ Make sure that no dispersive media (e.g., dust, fog, or smoke) are within the calculated minimum distance from the light beams.
-



DANGER

Hazard due to unexpected starting of the machine

- ▶ Make sure that the dangerous state of the machine is and remains switched off during the cleaning.
 - ▶ Make sure that the outputs of the safety multibeam sensor do not affect the machine during cleaning.
-

**NOTICE**

- ▶ Do not use any aggressive cleaning agents.
- ▶ Do not use any abrasive cleaning agents.
- ▶ We recommend anti-static cleaning agents.
- ▶ We recommend the use of anti-static plastic cleaner (SICK part number 5600006) and the SICK lens cloth (SICK part number 4003353).

Approach

1. Remove dust from the front screen using a soft, clean brush.
2. Then wipe the front screen with a clean, damp cloth.
3. Check the alignment of the active and passive units.
4. Check the effectiveness of the protective device.

Further topics

- ["Test rod check", page 27](#)

9.2 Regular thorough check

The thorough check is intended to ensure that the safety functions are fulfilling their planned purpose and whether persons are being adequately protected.

- ▶ Carry out the checks specified in the test plan of the manufacturer of the machine and the operating entity.

10 Troubleshooting

10.1 Overview

Information on the status as well as diagnostics and troubleshooting of the protective device can be displayed as follows:

- **Diagnostics LEDs**
Status and fault information, as well as diagnostics data, are displayed directly on the active unit by means of the diagnostics LEDs.
- **NFC**
Status and fault information, as well as diagnostics data, can be read out to an NFC-capable device by means of an integrated NFC interface.

Complementary information

You can find additional information on NFC in the SICK Safety Assistant app.

Further topics

- ["Diagnostic LEDs", page 56](#)

10.2 Safety



DANGER

Hazard due to lack of effectiveness of the protective device

Persons and parts of the body to be protected may not be recognized in case of non-observance.

- ▶ Immediately shut the machine down if the behavior of the machine cannot be clearly identified.
- ▶ Immediately put the machine out of operation if you cannot clearly identify or allocate the fault and if you cannot safely remedy the fault.
- ▶ Secure the machine so that it cannot switch on unintentionally.



NOTE

Additional information on troubleshooting can be found at the responsible SICK subsidiary.

10.3 Diagnostic LEDs

10.3.1 Status indicator

Overview

During operation, the status of the protective device is indicated with LEDs.

Active unit

Position of LEDs: [see figure 6, page 14](#)

Table 14: LEDs on the active unit during normal operation

LEDs										Meaning	
ERR	OSSD	Diagnostics LEDs									
		1	2	3	4	5	6	7	8		
○	● Green										The light path is clear.
○	● Red										The light path is interrupted.

○ LED off. ● LED flashes. ● LED illuminates. Empty cells mean that the LED lights up, flashes, or is off.

If front screen contamination increases in ongoing operation or the alignment is poor for longer than 3 seconds, the active unit shows the alignment quality again.

Further topics

- ["Indication of the alignment quality", page 50](#)

10.3.2 Fault indicators

Overview

In the event of a fault, the type of fault is indicated by the LED display on the active unit.

Active unit

Position of LEDs: [see figure 6, page 14](#)

Table 15: Fault display on the active unit

LEDs										Possible cause	Troubleshooting
ERR	OSSD	Diagnostics LEDs									
		1	2	3	4	5	6	7	8		
Red	Red	Blue								An internal fault has occurred.	<ul style="list-style-type: none"> ▶ Switch the voltage supply off and back on again. ▶ If the fault continues to persist, replace the active unit, see "Ordering information", page 66.
Red	Red		Blue							Fault in the voltage supply.	<ul style="list-style-type: none"> ▶ Check the voltage supply and the power supply unit, see "Technical data", page 60. ▶ Switch the voltage supply off and back on again. ▶ If the fault continues to persist, replace the active unit, see "Ordering information", page 66.
Red	Red		Blue		Blue					Permanent error in the voltage supply.	<ul style="list-style-type: none"> ▶ Replace device, see "Ordering information", page 66.
Red	Red				Blue					A wiring fault has been identified at the OSSDs. E.g. overvoltage, short-circuit, cross-circuit, permissible load capacity exceeded.	<ul style="list-style-type: none"> ▶ Check the system wiring for a fault. Make sure that the OSSDs have been wired correctly, see "Integration in the electrical control system", page 22. ▶ Switch the voltage supply off and back on again. ▶ If the fault continues to persist, replace the defective components, see "Ordering information", page 66.

LED off. LED flashes. LED illuminates. Empty cells mean that the LED lights up, flashes, or is off.

11 Decommissioning

11.1 Disposal

Approach

- ▶ Always dispose of unusable devices in accordance with national waste disposal regulations.



Complementary information

SICK will be glad to help you dispose of these devices on request.

12 Technical data

12.1 Data sheet

General system data

Table 16: General system data

	Minimum	Typical	Maximum
Beam separation, depending on type	500 mm or 300 mm		
Number of beams, depending on type	2 or 4		
Resolution/test rod diameter	30 mm		
Dimension of the light path, depending on type ^{1) 2) 3) 4) 5)}			
Passive unit for short scanning ranges			
System with 2 beams	0.5 m ... 3 m	0.5 m ... 3.2 m	
System with 4 beams	0.5 m ... 3 m	0.5 m ... 3.2 m	
Passive unit for long scanning ranges			
System with 2 beams	0.5 m ... 8 m		
System with 4 beams	0.5 m ... 7 m		
Protection class ⁶⁾	III (IEC 61140)		
Enclosure rating	IP 65 (IEC 60529) IP 67 (IEC 60529)		
Supply voltage ^{7) 8)}	24 V DC (19.2 V DC ... 28.8 V DC)		
Residual ripple ⁹⁾			± 10%
Power consumption		2.4 W	
Type	Type 4 (IEC 61496-1)		
Category	Category 4 (ISO 13849-1)		
Performance level ¹⁰⁾	PL e (ISO 13849-1)		
Safety integrity level ¹⁰⁾	SIL3 (IEC 61508)		
SIL claim limit ¹⁰⁾	SILCL3 (IEC 62061)		
PFHd (mean probability of one dangerous failure per hour) ¹¹⁾	5.3×10^{-9}		
T _M (mission time)	20 years (ISO 13849-1)		
Safe status when an error occurs	At least one OSSD is in the OFF state.		
Power-up delay after supply voltage applied		2 s	

- 1) If the light path is very long, there is a possibility that all diagnostic LEDs 1...4 or 5...8 will not light up even when alignment is optimal.
- 2) The scanning range depends on which passive unit is used.
- 3) The minimum scanning range specifies a range in which a function is guaranteed to operate correctly and safely under industrial conditions. A sufficient level of signal reserve to ensure very high availability is included in the calculation.
- 4) The typical scanning range specifies a range in which the protective device operates correctly and safely under industrial conditions. The level of signal reserve is enough to ensure high availability.
- 5) The light path between the active and passive unit must not exceed the maximum scanning range.
- 6) SELV/PELV safety extra-low voltage.
- 7) The external voltage supply must be capable of bridging a brief power failure of 20 ms as specified in IEC 60204-1. Suitable power supply units are available as accessories from SICK.
- 8) A fuse rated maximum 4 A must be installed in the isolated 24 V DC power supply circuit to the device in order to limit the available current.
- 9) Within the limits of UV.
- 10) For more detailed information on the exact configuration of your machine, please contact your relevant SICK subsidiary.

11) The values apply for an installation height of up to 2,000 m above sea level. Additional information can be found at your SICK subsidiary.

Operating data

Table 17: Operating data

	Minimum	Typical	Maximum
System connection	Male connector, M12, 5-pin		
Length of cable	150 mm		
Cable diameter	4.3 mm		
Cable material	PVC		
Length of cable for connecting cables ¹⁾	see "Length of cable", page 62		
Ambient operating temperature ²⁾	-30 °C ... +55 °C		
Air humidity (non-condensing)	15% ... 95%		
Storage temperature	-30 °C ... +70 °C		
Housing cross-section of the active unit and the passive unit for short scanning ranges	31 mm × 34 mm, plus bracket, see "Dimensional drawings", page 63		
Housing cross-section of the passive unit for long scanning ranges	Dependent on the number of beams, see "Dimensional drawings", page 63		
Weight	Dependent on the number of beams, see "Table of weights", page 62		
Vibration resistance ³⁾	5 ... 150 Hz, 3,5 mm / 1 g (EN 60068-2-6)		
Shock resistance ⁴⁾	15 g / 6 ms (EN 60068-2-27)		
Class	3M4 (IEC TR 60721-4-3)		

- 1) Maximum permissible conductor resistance must be observed.
- 2) The cable belonging to the device incl. the associated connection plug must not be flexibly mounted under -25 °C.
- 3) Test conditions per axis: 1 octave/minute, 20 sweeps.
- 4) Test conditions per axis: 200 shocks.

Technical data of active unit

Table 18: Technical data of active unit

	Minimum	Typical	Maximum
Wavelength of sender		Near-infrared (NIR), invisible	
Output signal switching devices (OSSDs)	2 PNP semiconductors, short-circuit protected ¹⁾ , cross-circuit monitored		
Response time			20 ms
Duration of OFF state	100 ms		
Switch-on delay		2 x response time	
ON state, switching voltage HIGH (U_{eff}) ²⁾	$U_V - 2.25 V$	24 V	U_V
OFF state, switching voltage LOW ^{2) 3)}	0 V	0 V	2.0 V
Current-carrying capacity of the OSSDs			500 mA each
Leakage current			2 mA each
Load capacity			2.2 µF
Load inductance			2.2 H
Test pulse data ⁴⁾			

	Minimum	Typical	Maximum
Test pulse width		150 μ s	300 μ s
Test pulse rate	3 s ⁻¹	5 s ⁻¹	10 s ⁻¹
Discrepancy time (time offset between switching of OSSD2 and OSSD1)			1 ms
Permissible cable resistance ⁵⁾			
Supply cable			2 Ω
Cable between OSSD and load			2.5 Ω

- 1) Applies to the voltage range between -30 V and +30 V.
- 2) According to IEC 61131-2.
- 3) The specified values are the switching voltage supplied by the device. If higher voltages are implanted externally, the maximum value of 2.0 V can be exceeded.
- 4) When active, the outputs are tested cyclically (brief LOW). When selecting the downstream controllers, make sure that the test pulses do not result in deactivation when using the above parameters.
- 5) Limit the cable length to the specified values to ensure that the protective device functions correctly, particularly that a cross-circuit between the outputs is safely detected. (Also observe IEC 60204-1.) The specified values apply to the total resistance of each wire including contact and connector resistances.

12.2 Length of cable

Table 19: Connection cables for active unit

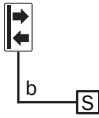
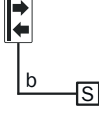
	Single system
Maximum lengths of cable for wire cross-section 0.34 mm ² , copper wire	 <p>b = 40 m</p>
Maximum lengths of cable for wire cross-section 0.25 mm ² , copper wire	 <p>b = 25 m</p>

S Control cabinet with safety relay or safety controller

12.3 Table of weights

Table 20: Weight of the active unit

Number of beams	Weight in g ¹⁾
2	555
4	890

1) Tolerance: \pm 50 g

Table 21: Weight of passive unit for small scanning range

Number of beams	Weight in g ¹⁾
2	520
4	845

1) Tolerance: \pm 50 g

Table 22: Weight of passive unit for large scanning range

Number of beams	Weight in g ¹⁾
2	575
4	950

¹⁾ Tolerance: ± 50 g

12.4 Dimensional drawings

Active unit

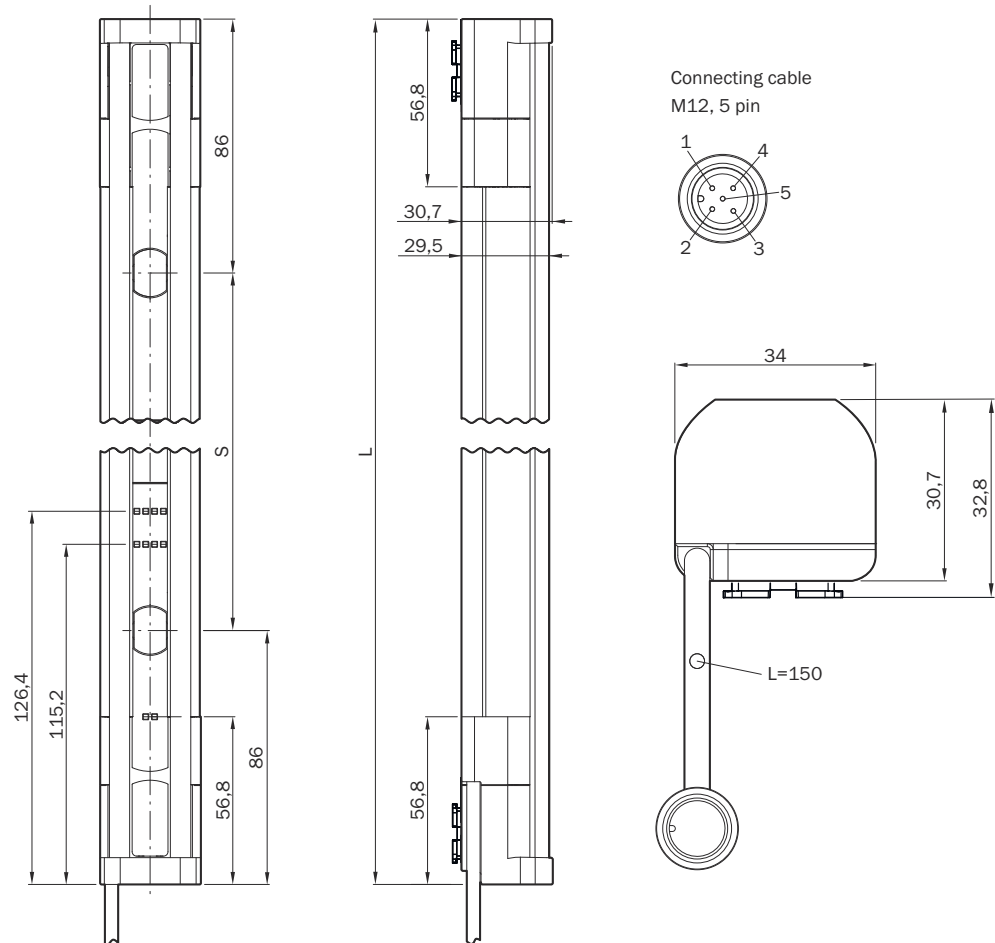

Figure 29: Dimensional drawing of active unit

Table 23: Dimensions based on the number of beams, active unit

Number of beams	Beam separation, dimension S in mm	Length, dimension L in mm
2	500	672
4	300	1072

Passive unit for small scanning range

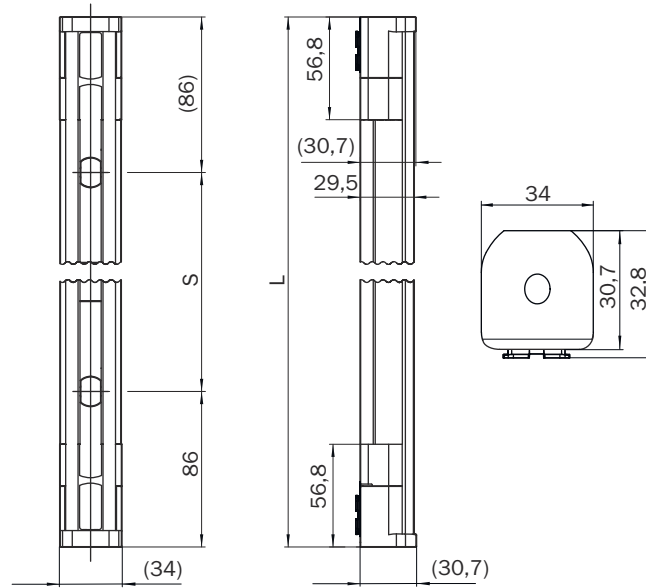

Figure 30: Dimensional drawing of passive unit for short scanning range

Table 24: Dimensions based on the number of beams, passive unit for small scanning range

Number of beams	Beam separation, dimension S in mm	Length, dimension L in mm
2	500	672
4	300	1072

Passive unit for large scanning range

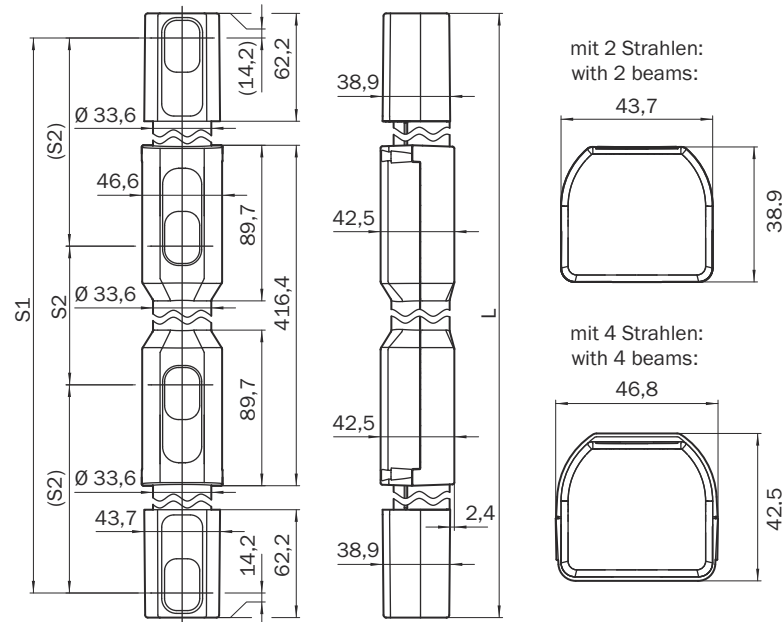

Figure 31: Dimensional drawing of passive unit for large scanning range

Table 25: Dimensions based on the number of beams, passive unit for large scanning ranges

Number of beams	Beam separation		Length, dimension L in mm
	Dimension S1 in mm	Dimension S2 in mm	
2	500	-	528.4
4	-	300	928.4

13 Ordering information

13.1 Scope of delivery

Scope of delivery of active unit

- Active unit
- Safety note
- Mounting instructions
- Operating instructions for download: www.sick.com

Scope of delivery of passive unit

- Passive unit

13.2 Ordering information

Table 26: Active unit order data

Number of beams	Active unit	
	Type code	Part number
2	M4C-ZA02500C10	1102644
4	M4C-ZA04300C10	1102645

Table 27: Ordering data of passive unit for small scanning range

Number of beams	Passive unit	
	Type code	Part number
2	PSN01-2501	1101921
4	PSN02-2301	1102144

Table 28: Ordering data of passive unit for large scanning range

Number of beams	Passive unit	
	Type code	Part number
2	PSN01-3501	1103066
4	PSN02-3301	1103067

14 Accessories

14.1 Brackets

Table 29: Brackets ordering information

Part	Type code	Part number
FlexFix bracket (2x)	BEF-1SHABPKU2	2098709
FlexFix bracket (4x)	BEF-1SHABPKU4	2066614
QuickFix bracket (2x)	BEF-3SHABPKU2	2066048
QuickFix bracket (4x)	BEF-3SHABPKU4	2098710
Compact FlexFix bracket (2x)	BEF-1SHTBPKU2	2117730
Compact FlexFix bracket (4x)	BEF-1SHTBPKU4	2117731
Flat mount bracket (2x)	BEF-3SHAHPKU2	2121705
Flat mount bracket (4x)	BEF-3SHAHPKU4	2118327
Swivel mount bracket (2x)	BEF-2SMJEPKU2	2121685
Swivel mount bracket (4x)	BEF-2SMJEPKU4	2118584
FlexFix mounting kit (2x FlexFix brackets, alignment tool, and assembly materials for installation in device columns)	BEF-1SHABBKU2	2073543
Replacement bracket (kit with 4 brackets, mounting kit for replacement of swivel mount brackets 2030510 or side bracket 2019506 with the FlexFix bracket when using the wells provided)	BEF-1SHABU004	2099282

FlexFix bracket

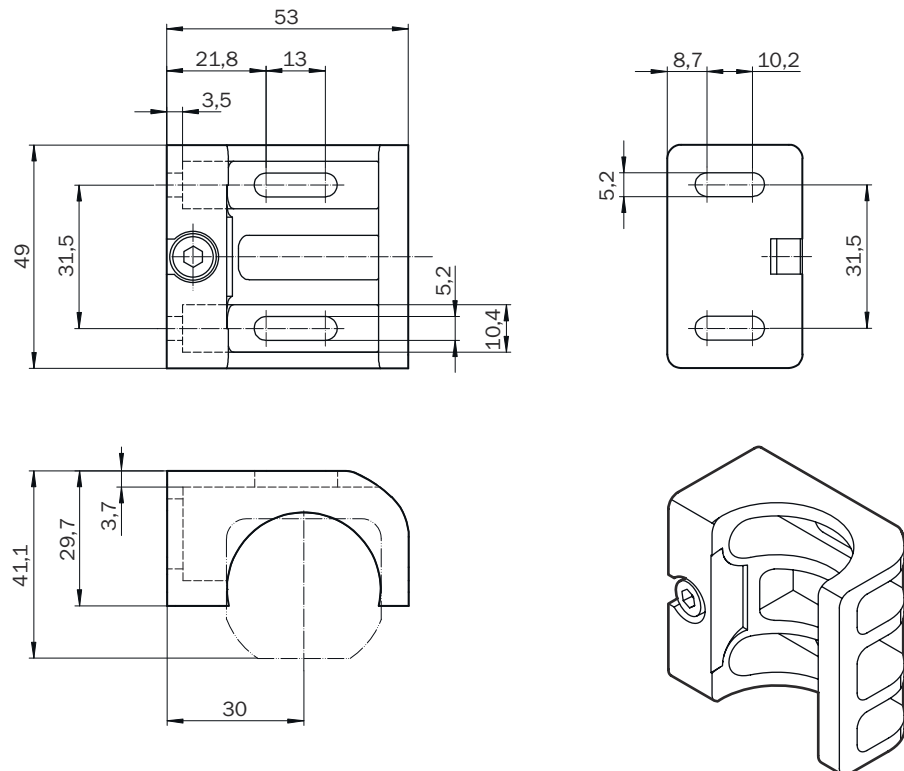

Figure 32: Dimensional drawing of the FlexFix bracket

QuickFix bracket

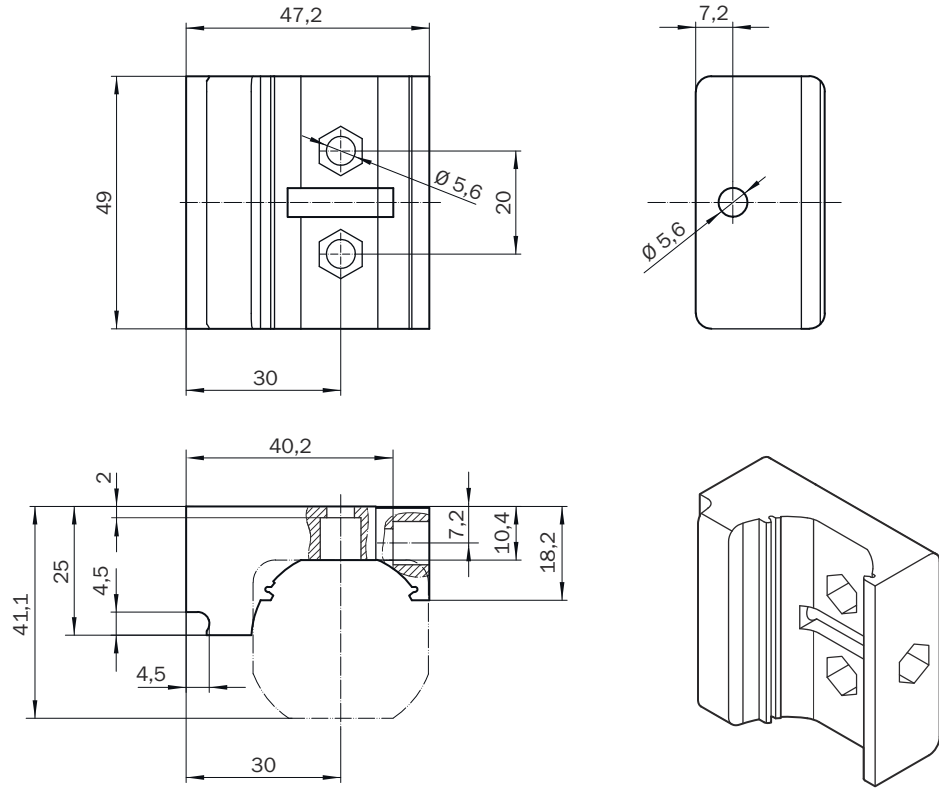

Figure 33: Dimensional drawing of the QuickFix bracket

Compact FlexFix bracket

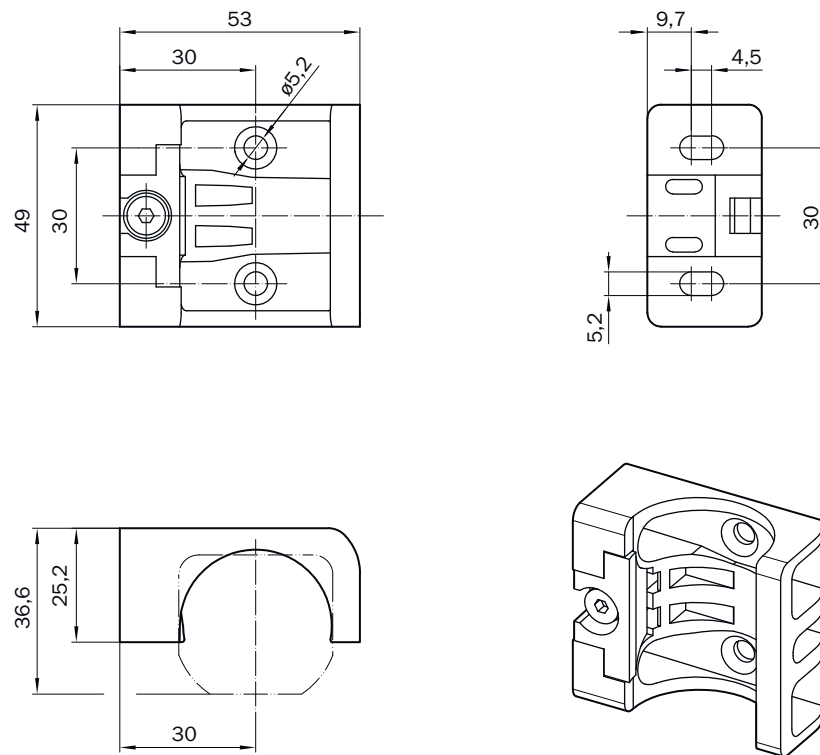

Figure 34: Dimensional drawing of the Compact FlexFix bracket

Flat mount bracket

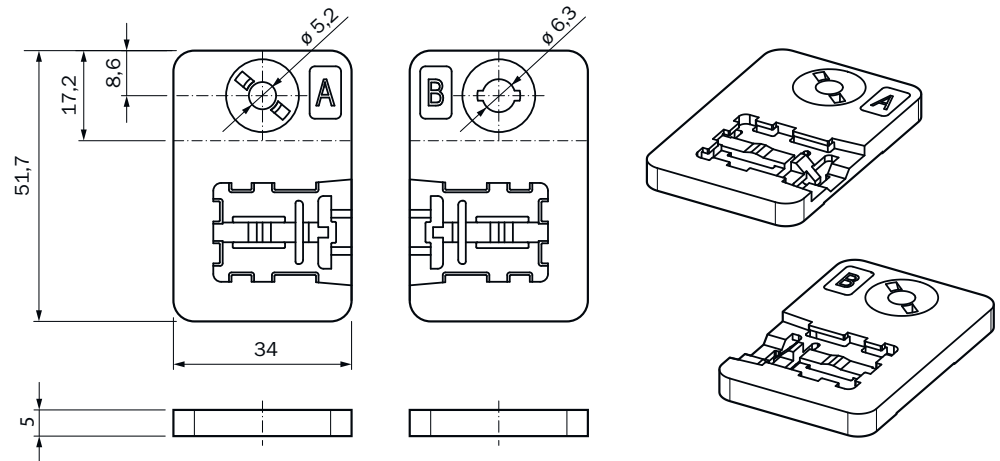

Figure 35: Dimensional drawing of the flat mount bracket

Swivel mount bracket

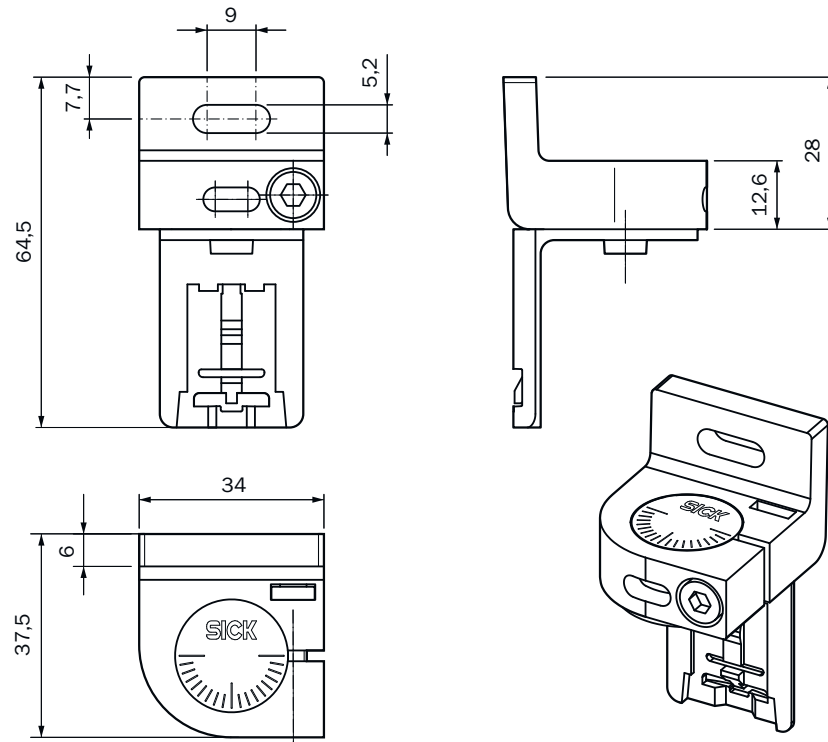

Figure 36: Dimensional drawing of the swivel mount bracket

14.2 Mounting accessories

Table 30: Mounting accessories ordering information

Part	Part number
Alignment tool	4084133

14.3 Weld spark guard

Function and use

The front screen of the active unit and the passive unit can also be protected with the weld spark guard for small scanning ranges.



NOTE

The weld spark guard cannot be used on the passive unit for small scanning ranges.

The weld spark guard reduces the scanning range of the system as follows:

- Weld spark guard on the active unit and the passive unit for small scanning ranges:
The system scanning range is reduced by 30%.
- Weld spark guard of the active unit and the passive unit for small scanning ranges:
The system scanning range is reduced by 15%.
- Weld spark guard of the active unit and use of a passive unit for large scanning ranges:
The system scanning range is reduced by 15%.

Table 31: Weld spark guard ordering information

Part	Part number
Weld spark guard	2069268

Mounting

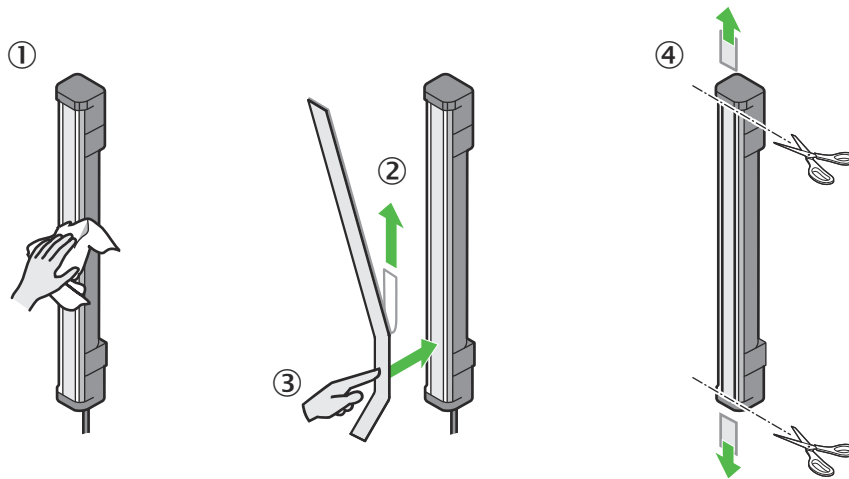

Figure 37: Mount the weld spark guard

- ① Clean the front screen
- ② Remove backing film
- ③ Press against the weld spark guard
- ④ Cut off excess ends

14.4 Connectivity

Table 32: Ordering information for M12 connecting cable, 5-pin (0.34 mm²) ²⁾

Part	Type code	Part number
Female connector, straight, 2 m cable, flying leads	YF2A15-020UB5XLEAX	2095617

²⁾ Ambient operating temperature: Down to -30° C with fixed installation.

Part	Type code	Part number
Female connector, straight, 5 m cable, flying leads	YF2A15-050UB5XLEAX	2095618
Female connector, straight, 10 m cable, flying leads	YF2A15-100UB5XLEAX	2095619
Female connector, straight, 15 m cable, flying leads	YF2A15-150UB5XLEAX	2095620
Female connector, straight, 20 m cable, flying leads	YF2A15-200UB5XLEAX	2095614
Female connector, straight, 30 m cable, flying leads	YF2A15-300UB5XLEAX	2095621
Female connector, angled, 2 m cable, flying leads	YG2A15-020UB5XLEAX	2095772
Female connector, angled, 5 m cable, flying leads	YG2A15-050UB5XLEAX	2095773
Female connector, angled, 10 m cable, flying leads	YG2A15-100UB5XLEAX	2095774

Table 33: Ordering information for M12 connection cable, 5-pin (0.34 mm²)³⁾

Part	Type code	Part number
Female connector, straight, 0.6 m cable, male connector, straight	YF2A15-C60UB5M2A15	2096006
Female connector, straight, 1 m cable, male connector, straight	YF2A15-010UB5M2A15	2096007
Female connector, straight, 2 m cable, male connector, straight	YF2A15-020UB5M2A15	2096009
Female connector, straight, 5 m cable, male connector, straight	YF2A15-050UB5M2A15	2096010
Female connector, straight, 10 m cable, male connector, straight	YF2A15-100UB5M2A15	2096011
Female connector, straight, 15 m cable, male connector, straight	YF2A15-150UB5M2A15	2096171

Table 34: Ordering information for power supply

Part	Type code	Part number
Output 24 V DC, 50 W (2.1 A), voltage supply NEC Class 2, SELV, PELV, input 120 V AC ... 240 V AC	PS50WE24V	7028789
Output 24 V DC, 95 W (3.9 A), voltage supply NEC Class 2, SELV, PELV, input 100 V AC ... 120 V / 220 V AC ... 240 V AC	PS95WE24V	7028790

14.5 Alignment aid

Table 35: Alignment aid ordering information

Part	Part number
Laser alignment aid AR60	1015741
Adapter ¹⁾	4070854

¹⁾ The adapter is mandatory for mounting the laser alignment aid on the protective device.

³⁾ Ambient operating temperature: Down to -30° C with fixed installation.

14.6 Device columns

Table 36: Ordering information for device columns

Column height	Max. installation length	Type code	Part number
985 mm	965 mm	PU3H96-00000000	2045490
1185 mm	1165 mm	PU3H11-00000000	2045641
1285 mm	1265 mm	PU3H13-00000000	2045642
1570 mm	1550 mm	PU3H15-00000000	2068813
1740 mm	1720 mm	PU3H17-00000000	2045643
2040 mm	2020 mm	PU3H21-00000000	2045644
2270 mm	2250 mm	PU3H22-00000000	2045645
2420 mm	2400 mm	PU3H24-00000000	2045646

14.7 Cleaning agent

Table 37: Cleaning agent ordering information

Part	Part number
Anti-static plastic cleaner	5600006
Lens cloth	4003353

14.8 Test rods

Table 38: Ordering information, test rods

Part	Part number
Test rod 30 mm	2022602
Test rod holder	2052249

15 Annex

15.1 Conformities and certificates

You can obtain declarations of conformity, certificates, and the current operating instructions for the product at www.sick.com. To do so, enter the product part number in the search field (part number: see the entry in the “P/N” or “Ident. no.” field on the type label).

15.1.1 EU declaration of conformity

Excerpt

The undersigned, representing the manufacturer, herewith declares that the product is in conformity with the provisions of the following EU directive(s) (including all applicable amendments), and that the standards and/or technical specifications stated in the EU declaration of conformity have been used as a basis for this.

- ROHS DIRECTIVE 2011/65/EU
- MACHINERY DIRECTIVE 2006/42/EC
- RE DIRECTIVE 2014/53/EU

15.1.2 UK declaration of conformity

Excerpt

The undersigned, representing the following manufacturer herewith declares that this declaration of conformity is issued under the sole responsibility of the manufacturer. The product of this declaration is in conformity with the provisions of the following relevant UK Statutory Instruments (including all applicable amendments), and the respective standards and/or technical specifications have been used as a basis.

- Restriction of the Use of Certain Hazardous Substances in Electrical and Electronic Equipment Regulations 2012
- Supply of Machinery (Safety) Regulations 2008
- Radio Equipment Regulations 2017

15.2 Note on standards

Standards are specified in the information provided by SICK. The table shows regional standards with similar or identical contents. Not every standard applies to all products.

Table 39: Note on standards

Standard	Standard (regional)
	China
IEC 60068-2-6	GB/T 2423.10
IEC 60068-2-27	GB/T 2423.5
IEC 60204-1	GB/T 5226.1
IEC 60529	GB/T 4208
IEC 60825-1	GB 7247.1
IEC 61131-2	GB/T 15969.2
IEC 61140	GB/T 17045
IEC 61496-1	GB/T 19436.1
IEC 61496-2	GB/T 19436.2
IEC 61496-3	GB 19436.3
IEC 61508	GB/T 20438

Standard	Standard (regional)
	China
IEC 62061	GB 28526
ISO 13849-1	GB/T 16855.1
ISO 13855	GB/T 19876

15.3 Checklist for initial commissioning and commissioning

Checklist for manufacturers or installers for installing electro-sensitive protective device (ESPE)

The details relating to the items listed below must be available no later than when the system is commissioned for the first time. However, these depend on the specific application (the requirements of which must be reviewed by the manufacturer or installer).

This checklist should be retained and kept with the machine documentation to serve as reference during recurring tests.

This checklist does not replace the initial commissioning, nor the regular inspection by qualified safety personnel.

Have the safety rules and regulations been observed in compliance with the directives and standards applicable to the machine?	Yes <input type="checkbox"/> No <input type="checkbox"/>
Are the applied directives and standards listed in the declaration of conformity?	Yes <input type="checkbox"/> No <input type="checkbox"/>
Does the protective device correspond to the required PL/SIL and PFHd in accordance with ISO 13849-1 / IEC 62061 and the required type in accordance with IEC 61496-1?	Yes <input type="checkbox"/> No <input type="checkbox"/>
Is access to the hazardous area or hazardous point only possible through the protective field of the ESPE?	Yes <input type="checkbox"/> No <input type="checkbox"/>
Have appropriate measures been taken to protect (mechanical protection) or monitor (protective devices) any persons or objects in the hazardous area when protecting a hazardous area or hazardous point, and have these devices been secured or locked to prevent their removal?	Yes <input type="checkbox"/> No <input type="checkbox"/>
Are additional mechanical protective measures fitted and secured against manipulation which prevent reaching below, above or around the ESPE?	Yes <input type="checkbox"/> No <input type="checkbox"/>
Has the maximum shutdown and/or stopping time of the machine been measured, specified and documented (at the machine and/or in the machine documentation)?	Yes <input type="checkbox"/> No <input type="checkbox"/>
Has the ESPE been mounted such that the required minimum distance from the nearest hazardous point has been achieved?	Yes <input type="checkbox"/> No <input type="checkbox"/>
Are the ESPE devices properly mounted and secured against manipulation after adjustment?	Yes <input type="checkbox"/> No <input type="checkbox"/>
Are the required protective measures against electric shock in effect (protection class)?	Yes <input type="checkbox"/> No <input type="checkbox"/>
Is the control switch for resetting the protective devices (ESPE) or restarting the machine present and correctly installed?	Yes <input type="checkbox"/> No <input type="checkbox"/>
Are the outputs of the ESPE (OSSDs or safety outputs via the network) integrated according to the required PL/SIL in accordance with ISO 13849-1 / IEC 62061 and does the integration correspond to the circuit diagrams?	Yes <input type="checkbox"/> No <input type="checkbox"/>
Has the protective function been checked in compliance with the test notes of this documentation?	Yes <input type="checkbox"/> No <input type="checkbox"/>
Are the specified protective functions effective at every operating mode that can be set?	Yes <input type="checkbox"/> No <input type="checkbox"/>
Are the switching elements activated by the ESPE, e.g. contactors, valves, monitored?	Yes <input type="checkbox"/> No <input type="checkbox"/>
Is the ESPE effective over the entire period of the dangerous state?	Yes <input type="checkbox"/> No <input type="checkbox"/>
Once initiated, will a dangerous state be stopped when switching the ESPE on or off and when changing the operating mode, or when switching to another protective device?	Yes <input type="checkbox"/> No <input type="checkbox"/>

16 List of figures

1.	Active and passive units.....	10
2.	Overview of the active unit.....	11
3.	Overview of the passive unit for small scanning ranges.....	12
4.	Overview of the passive unit for large scanning ranges.....	12
5.	NFC symbol	13
6.	Status indicators of the active unit.....	14
7.	Access protection.....	15
8.	Minimum distance from the hazardous point.....	19
9.	Minimum distance from reflective surfaces.....	20
10.	Graph of minimum distance from reflective surfaces.....	20
11.	Upset condition 1: Preventing mutual interference from system ① and system ②	21
12.	Upset condition 2: Preventing mutual interference from system ① and system ②	21
13.	Interference-free operation due to an opposite transmission direction of adjacent systems.....	22
14.	Dual-channel and isolated connection of OSSD1 and OSSD2.....	23
15.	No potential difference between load and protective device.....	23
16.	Schematic representation of operation with restart interlock.....	24
17.	Connection diagram for RLY3-OSSD2 with restart interlock and external device monitoring.....	25
18.	Mounting the QuickFix bracket on a profile.....	34
19.	Mount FlexFix bracket to a profile frame.....	36
20.	Inserting the protective device in the FlexFix brackets.....	36
21.	Mounting the FlexFix bracket on a device column (accessory).....	37
22.	Mount the Compact FlexFix bracket on a profile frame.....	38
23.	Inserting the protective device in the Compact FlexFix brackets.....	39
24.	System connection (male connector, M12, 5-pin).....	44
25.	QuickFix bracket: Vertical adjustment.....	47
26.	FlexFix bracket: Vertical adjustment / rotation.....	48
27.	Compact FlexFix bracket: Rotate.....	49
28.	Swivel mount bracket: Rotate.....	49
29.	Dimensional drawing of active unit.....	63
30.	Dimensional drawing of passive unit for short scanning range.....	64
31.	Dimensional drawing of passive unit for large scanning range.....	64
32.	Dimensional drawing of the FlexFix bracket.....	67
33.	Dimensional drawing of the QuickFix bracket.....	68
34.	Dimensional drawing of the Compact FlexFix bracket.....	68
35.	Dimensional drawing of the flat mount bracket.....	69
36.	Dimensional drawing of the swivel mount bracket.....	69
37.	Mount the weld spark guard.....	70

17 List of tables

1.	Target groups and selected sections of these operating instructions.....	6
2.	Colors and their meaning.....	14
3.	Indication of the alignment quality.....	14
4.	Fault indication.....	15
5.	Formula for calculating the minimum distance from reflective surfaces.....	20
6.	Tightening torques depending on the bracket used.....	32
7.	Side and rear mounting with the QuickFix bracket.....	34
8.	Lateral and rear mounting with the FlexFix bracket.....	35
9.	Side and rear mounting of the Compact FlexFix bracket on a machine or profile frame.....	38
10.	System connection pin assignment (male connector, M12, 5-pin).....	44
11.	Display of alignment quality (system with 2 beams).....	50
12.	Display of alignment quality (system with 4 beams).....	50
13.	LEDs on the active unit during normal operation.....	53
14.	LEDs on the active unit during normal operation.....	57
15.	Fault display on the active unit.....	58
16.	General system data.....	60
17.	Operating data.....	61
18.	Technical data of active unit.....	61
19.	Connection cables for active unit.....	62
20.	Weight of the active unit.....	62
21.	Weight of passive unit for small scanning range.....	62
22.	Weight of passive unit for large scanning range.....	63
23.	Dimensions based on the number of beams, active unit.....	63
24.	Dimensions based on the number of beams, passive unit for small scanning range.....	64
25.	Dimensions based on the number of beams, passive unit for large scanning ranges.....	65
26.	Active unit order data.....	66
27.	Ordering data of passive unit for small scanning range.....	66
28.	Ordering data of passive unit for large scanning range.....	66
29.	Brackets ordering information.....	67
30.	Mounting accessories ordering information.....	69
31.	Weld spark guard ordering information.....	70
32.	Ordering information for M12 connecting cable, 5-pin (0.34 mm ²)	70
33.	Ordering information for M12 connection cable, 5-pin (0.34 mm ²)	71
34.	Ordering information for power supply.....	71
35.	Alignment aid ordering information.....	71
36.	Ordering information for device columns.....	72
37.	Cleaning agent ordering information.....	72
38.	Ordering information, test rods.....	72
39.	Note on standards.....	73

Australia

Phone +61 (3) 9457 0600
1800 33 48 02 – tollfree
E-Mail sales@sick.com.au

Austria

Phone +43 (0) 2236 62288-0
E-Mail office@sick.at

Belgium/Luxembourg

Phone +32 (0) 2 466 55 66
E-Mail info@sick.be

Brazil

Phone +55 11 3215-4900
E-Mail comercial@sick.com.br

Canada

Phone +1 905.771.1444
E-Mail cs.canada@sick.com

Czech Republic

Phone +420 234 719 500
E-Mail sick@sick.cz

Chile

Phone +56 (2) 2274 7430
E-Mail chile@sick.com

China

Phone +86 20 2882 3600
E-Mail info.china@sick.net.cn

Denmark

Phone +45 45 82 64 00
E-Mail sick@sick.dk

Finland

Phone +358-9-25 15 800
E-Mail sick@sick.fi

France

Phone +33 1 64 62 35 00
E-Mail info@sick.fr

Germany

Phone +49 (0) 2 11 53 010
E-Mail info@sick.de

Greece

Phone +30 210 6825100
E-Mail office@sick.com.gr

Hong Kong

Phone +852 2153 6300
E-Mail ghk@sick.com.hk

Hungary

Phone +36 1 371 2680
E-Mail ertekesites@sick.hu

India

Phone +91-22-6119 8900
E-Mail info@sick-india.com

Israel

Phone +972 97110 11
E-Mail info@sick-sensors.com

Italy

Phone +39 02 27 43 41
E-Mail info@sick.it

Japan

Phone +81 3 5309 2112
E-Mail support@sick.jp

Malaysia

Phone +603-8080 7425
E-Mail enquiry.my@sick.com

Mexico

Phone +52 (472) 748 9451
E-Mail mexico@sick.com

Netherlands

Phone +31 (0) 30 229 25 44
E-Mail info@sick.nl

New Zealand

Phone +64 9 415 0459
0800 222 278 – tollfree
E-Mail sales@sick.co.nz

Norway

Phone +47 67 81 50 00
E-Mail sick@sick.no

Poland

Phone +48 22 539 41 00
E-Mail info@sick.pl

Romania

Phone +40 356-17 11 20
E-Mail office@sick.ro

Russia

Phone +7 495 283 09 90
E-Mail info@sick.ru

Singapore

Phone +65 6744 3732
E-Mail sales.gsg@sick.com

Slovakia

Phone +421 482 901 201
E-Mail mail@sick-sk.sk

Slovenia

Phone +386 591 78849
E-Mail office@sick.si

South Africa

Phone +27 10 060 0550
E-Mail info@sickautomation.co.za

South Korea

Phone +82 2 786 6321/4
E-Mail infokorea@sick.com

Spain

Phone +34 93 480 31 00
E-Mail info@sick.es

Sweden

Phone +46 10 110 10 00
E-Mail info@sick.se

Switzerland

Phone +41 41 619 29 39
E-Mail contact@sick.ch

Taiwan

Phone +886-2-2375-6288
E-Mail sales@sick.com.tw

Thailand

Phone +66 2 645 0009
E-Mail marcom.th@sick.com

Turkey

Phone +90 (216) 528 50 00
E-Mail info@sick.com.tr

United Arab Emirates

Phone +971 (0) 4 88 65 878
E-Mail contact@sick.ae

United Kingdom

Phone +44 (0)17278 31121
E-Mail info@sick.co.uk

USA

Phone +1 800.325.7425
E-Mail info@sick.com

Vietnam

Phone +65 6744 3732
E-Mail sales.gsg@sick.com

Detailed addresses and further locations at www.sick.com

