

OPERATING INSTRUCTIONS

S200

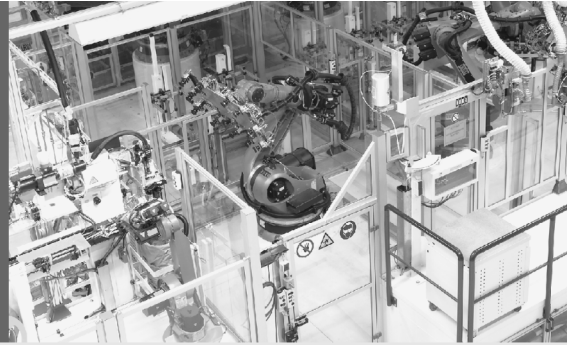

Safety Laser Scanner

GB



**SICK**  
Sensor Intelligence.

This document is protected by the law of copyright, whereby all rights established therein remain with the company SICK AG. Reproduction of this document or parts of this document is only permissible within the limits of the legal determination of Copyright Law. Alteration or abridgement of the document is not permitted without the explicit written approval of the company SICK AG.



certified by DQS according to  
DIN EN ISO 9001 Reg. No. 462-03

**Contents**

<b>1</b>	<b>About this document.....</b>	<b>6</b>
1.1	Function of this document.....	6
1.2	Target group .....	6
1.3	Scope .....	6
1.4	Depth of information.....	7
1.5	Abbreviations.....	7
1.6	Symbols used .....	8
<b>2</b>	<b>On safety.....</b>	<b>9</b>
2.1	Correct use .....	9
2.2	Specialist personnel.....	9
2.3	Applications of the device.....	10
2.4	General safety notes and protective measures .....	10
2.5	Environmental protection .....	12
2.5.1	Disposal .....	12
2.5.2	Separation of materials .....	12
2.6	Applicable directives and standards.....	13
<b>3</b>	<b>Product description .....</b>	<b>14</b>
3.1	Device components .....	14
3.2	Special features .....	15
3.3	Function.....	15
3.3.1	Principles of operation .....	16
3.3.2	Field set comprising of protective field and warning field .....	17
3.4	Applications .....	18
3.4.1	Stationary applications .....	18
3.4.2	Mobile applications.....	20
3.5	Configurable functions.....	21
3.5.1	Field set .....	21
3.5.2	Application and resolution.....	23
3.5.3	Using the contour as a reference.....	23
3.5.4	External device monitoring (EDM).....	25
3.5.5	Application diagnostic output “Error/contamination”.....	25
3.5.6	Restart .....	25
3.5.7	Multiple sampling.....	27
3.5.8	Stand-by mode .....	28
3.5.9	Naming applications and laser scanners .....	28
3.6	Indicators and outputs.....	28
3.6.1	LEDs and 7-segment display .....	28
3.6.2	Outputs .....	29

<b>4</b>	<b>Mounting</b> .....	<b>30</b>
4.1	Stationary application in horizontal operation.....	31
4.1.1	Protective field size.....	31
4.2	Stationary vertical operation for access protection.....	35
4.2.1	Safety distance.....	35
4.3	Stationary vertical operation for hazardous point protection.....	37
4.3.1	Safety distance.....	37
4.4	Mobile applications.....	38
4.5	Methods of preventing unprotected areas.....	39
4.5.1	Near range.....	39
4.6	Mounting steps.....	40
4.6.1	Direct mounting.....	41
4.6.2	Mounting with mounting kit 1a or 1b.....	41
4.6.3	Mounting with mounting kit 2 and 3.....	43
4.6.4	Information label Important information.....	43
4.6.5	Using multiple S200 safety laser scanners.....	44
<b>5</b>	<b>Electrical installation</b> .....	<b>46</b>
5.1	System connection.....	47
5.1.1	Pin assignment on the system plug.....	47
5.1.2	OSSDs.....	47
5.1.3	Functional earth.....	47
5.2	System plug assembly.....	48
5.3	Pre-assembled system plugs.....	49
<b>6</b>	<b>Application examples and connection diagrams</b> .....	<b>50</b>
6.1	Stationary applications.....	50
6.1.1	Applications with one monitored area.....	50
6.2	Connection diagrams.....	51
6.2.1	Restart interlock and external device monitoring.....	51
<b>7</b>	<b>Configuration</b> .....	<b>52</b>
7.1	Default delivery status.....	52
7.2	Preparation of the configuration.....	52
<b>8</b>	<b>Commissioning</b> .....	<b>53</b>
8.1	Initial commissioning.....	53
8.1.1	Power up sequence.....	53
8.2	Re-commissioning.....	54
8.2.1	Power up sequence.....	54
8.3	Test notes.....	55
8.3.1	Pre-commissioning tests.....	55
8.3.2	Regular inspection of the protective device by qualified personnel.....	56
8.3.3	Daily testing of the protective device by a specialist or authorised personnel.....	56
<b>9</b>	<b>Care and maintenance</b> .....	<b>57</b>
9.1	Cleaning optics cover.....	57
9.2	Replacing optics cover.....	57

<b>10</b>	<b>Diagnostics</b> .....	<b>59</b>
10.1	In the event of faults or errors.....	59
10.2	SICK support.....	59
10.3	Error and status indications on the LEDs .....	59
10.4	Error and status indications on the 7-segment display .....	61
10.5	Extended diagnostics.....	63
<b>11</b>	<b>Technical specifications</b> .....	<b>64</b>
11.1	Characteristics .....	64
11.2	OSSD response times .....	64
11.3	Timing behaviour of the OSSDs.....	66
11.4	Data sheet .....	68
11.5	Dimensional drawings .....	74
11.5.1	S200 .....	74
11.5.2	Mounting kits.....	74
11.5.3	Scan plane origin .....	76
<b>12</b>	<b>Ordering information</b> .....	<b>77</b>
12.1	Delivery S200.....	77
12.2	Available systems.....	77
12.3	Accessories/spare parts.....	77
12.3.1	Mounting kits.....	77
12.3.2	System plug S200.....	77
12.3.3	Service cable .....	78
12.3.4	Self assembly connecting cables .....	78
12.3.5	On the documentation .....	78
12.3.6	Safety relays .....	78
12.3.7	Safety controllers .....	78
12.3.8	Miscellaneous .....	78
<b>13</b>	<b>Annex</b> .....	<b>79</b>
13.1	Declaration of conformity .....	79
13.2	Manufacturer's checklist.....	80
13.3	Glossary .....	81
13.4	List of tables .....	82
13.5	List of illustrations.....	82

# 1 About this document

Please read this chapter carefully before working with this documentation and the S200.

## 1.1 Function of this document

These operating instructions are designed to address *the technical personnel of the machine manufacturer or the machine operator* in regards to correct mounting, electrical installation, commissioning, operation and maintenance of the S200 safety laser scanner.

These operating instructions do *not* provide instructions for operating the machine, the system or the vehicle on which the safety laser scanner is, or will be, integrated.

Information on this is to be found in the appropriate operating instructions for the machine, the system or the vehicle.

## 1.2 Target group

These operating instructions are addressed to *planning engineers, machine designers and the operators* of machines and systems which are to be protected by one or several S200 safety laser scanners. They also address people who integrate the S200 into a machine, a system or a vehicle, initialise its use, or who are in charge of servicing and maintaining the device.

## 1.3 Scope

This document is an original document.

These operating instructions are applicable to the S200 safety laser scanner with one of the following entries on the type label in the field *Operating Instructions*:

- 8011690
- 8011690/TL61

This document is part of SICK part number 8011690 (operating instructions “S200 – Safety Laser Scanner” in all available languages).

For the configuration and diagnostics of these devices you require CDS (Configuration & Diagnostic Software) version 3.3 or higher. To determine the version of your software version, select the **Module-Info...** option in the **?** menu.

## 1.4 Depth of information

These operating instructions contain information on the S200 safety laser scanner. They have the following parts:

- mounting
- electrical installation
- commissioning and configuration
- care and maintenance
- fault, error diagnosis and troubleshooting
- part numbers
- accessories
- conformity and approval

Planning and using protective devices such as the S200 also require specific technical skills which are not detailed in this documentation.

General information on accident prevention using opto-electronic protective devices can be found in the brochure “Safe Machines with opto-electronic protective devices”.

When operating the S200, the national, local and statutory rules and regulations must be observed.

**Note** We also refer you to the SICK AG homepage on the Internet at: [www.sick.com](http://www.sick.com)

Here you will find information on:

- application examples
- a list of frequently asked questions regarding the S200
- these operating instructions in different languages for viewing and printing

## 1.5 Abbreviations

<b>AGV</b>	Automated Guided Vehicle
<b>ANSI</b>	American National Standards Institute
<b>AWG</b>	American Wire Gauge = standardisation and classification of wires and cables by type, diameter etc.
<b>CDS</b>	SICK Configuration & Diagnostic Software = software for the configuration and diagnostics of the S200
<b>EDM</b>	External device monitoring = e.g. external device monitoring
<b>EMC</b>	Electromagnetic compatibility
<b>ESD</b>	Electrostatic discharge = electrostatic discharge
<b>ESPE</b>	Electro-sensitive protective equipment
<b>FPLC</b>	Fail-safe programmable logic controller
<b>OSSD</b>	Output signal switching device = signal output of the protective device that is used to stop the dangerous movement
<b>RIA</b>	Robotic Industries Association

## 1.6 Symbols used

**Recommendation** Recommendations are designed to give you some assistance in your decision-making process with respect to a certain function or a technical measure.

**Note** Refer to notes for special features of the device.

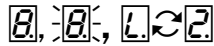

Display indicators show the status of the 7-segment display on the S200:

Constant indication of characters, e.g. 8

Flashing indication of characters, e.g. 8

Alternating indication of characters, e.g. L and 2



LED symbols describe the status of an LED:

The "OSSDs in the OFF state" LED is illuminated continuously.

The "Error/contamination" LED is flashing.

The LED is deactivated.

➤ Take action ... Instructions for taking action are shown by an arrow. Read carefully and follow the instructions for action.



WARNING

### Warning!

A warning indicates an actual or potential risk or health hazard. Observation and implementation of the warning will protect you from accidents.

Read carefully and follow the warning notices!



Information is displayed in the software indicating to you which settings you can make in the CDS (Configuration & Diagnostic Software).



## 2 On safety

This chapter deals with your own safety and the safety of the equipment operators.

➤ Please read this chapter carefully before working with the S200 or with the machine protected by the S200.

### 2.1 Correct use

The S200 safety laser scanner must be used only as defined in chapter 2.3 “Applications of the device” on page 10. It must be used only by qualified personnel on the machine where it has been installed and initialised by specialist personnel in accordance with these operating instructions. It is only permitted to be used on machines on which the dangerous state can be stopped immediately by the S200 and/or it is possible to prevent the machine being placed in operation.

**Note** If the device is used for any other purposes or modified in any way – also during mounting and installation – any warranty claim against SICK AG shall become void.

### 2.2 Specialist personnel

The S200 safety laser scanner must be installed, connected, commissioned and serviced only by specialist personnel. Specialist personnel are defined as persons who

- due to their specialist training and experience have adequate knowledge of the power-driven equipment to be checked

**and**

- who have been instructed by the responsible machine operator in the operation of the machine and the current valid safety guidelines

**and**

- are sufficiently familiar with the applicable official health and safety regulations, directives and generally recognized engineering practice (e.g. DIN standards, VDE stipulations, engineering regulations from other EC member states) that they can assess the work safety aspects of the power-driven equipment

**and**

- who have access to these operating instructions and who have read them.

As a rule these are specialist personnel from the ESPE manufacturer or also those persons who have been appropriately trained at the ESPE manufacturer, are primarily involved in checking ESPE and are allocated the task by the organisation operating the ESPE.

## 2.3 Applications of the device

The S200 safety laser scanner is used to protect persons and plant. It is intended to be used to monitor hazardous areas indoors.

It is not allowed to use the S200 outdoors.

The S200 cannot provide protection from parts thrown out of the machine or radiation emitted.

The S200 complies with the requirements in the standard on the radiated emissions as defined for class A (industrial application); the S200 is therefore only suitable for use in an industrial environment.

The safety level of the S200 corresponds to category 2 in accordance with EN ISO 13849-1, type 2 in accordance with EN 61496-1 and SIL1 in accordance with IEC 61508. The S200 is suitable for:

- hazardous area protection
- hazardous point protection
- access protection
- vehicle protection (electrically powered industrial trucks)

**Note** Depending on the application, other protective devices and measures may be required in addition to the safety laser scanner.

## 2.4 General safety notes and protective measures



WARNING

### Pay attention to the safety notes!

Please observe the following items in order to ensure the correct use of the S200 safety laser scanner.

**CLASS 1  
LASER PRODUCT**

IEC 60825-1:2001. Complies with 21 CFR 1040.10 and 1040.11 except for deviations pursuant to Laser Notice No.50, July 2001.

DESCRIPTION OF THE LASER WARNING LABEL:  
IEC 60825-1:2001. Complies with 21 CFR 1040.10 and 1040.11 except for deviations pursuant to Laser Notice No. 50, July 2001.

- This device meets the norms: CDRH 21 CFR 1040.10 and 1040.11 as well as IEC 60825-1 edition 1.2:2001-08. There the following note is required: “Caution – if devices for operation or adjustment different to those given here are used or other procedures are employed, hazardous exposure to radiation may occur!”
- During the mounting, installation and usage of the S200, observe the standards and directives applicable in your country. You will find an overview of the most important regulations in section 2.6 “Applicable directives and standards” on page 13.
- The national/international rules and regulations apply to the installation, commissioning, use and periodic technical inspections of the S200 safety laser scanner, in particular ...
  - Machinery Directive 2006/42/EC
  - Work Equipment Directive 89/655/EEC.
  - the work safety regulations/safety rules.
  - other relevant health and safety regulations.

**S200**

- Manufacturers and operators of the machine on which the S200 is used are responsible for obtaining and observing all applicable safety regulations and rules.
  - The notes, in particular the test notes (see chapter 8 “Commissioning” on page 53) in these operating instructions (e.g. on use, mounting, installation or integration into the machine controller) must be observed.
  - Changes to the configuration of the devices can degrade the protective function. After every change to the configuration you must therefore check the effectiveness of the protective device. The person who makes the change is also responsible for the correct protective function of the device. When making configuration changes, please always use the password hierarchy provided by SICK to ensure that only authorised persons make changes to the configuration. The SICK service team is available to provide assistance if required.
  - The tests must be carried out by specialist personnel or specially qualified and authorised personnel and must be recorded and documented to ensure that the tests can be reconstructed and retraced at any time.
  - The operating instructions must be made available to the operator of the machine where the S200 is used. The machine operator is to be instructed in the use of the device by specialist personnel and must be instructed to read the operating instructions.
  - The external voltage supply of the devices must be capable of buffering brief mains voltage failures of 20 ms as specified in EN 60 204-1. Suitable power supplies are available as accessories from SICK (see section 12.3 “Accessories/spare parts” on page 78).
- Enclosed with these operating instructions is a checklist for checking by the manufacturer and OEM (see section 13.2 “Manufacturer’s checklist” on page 80). Use this checklist when checking the plant that is protected with the S200.

**The term “dangerous state”**

The *dangerous state* (standard term) of the machine is always shown in the drawings and diagrams of this document as a movement of a machine part. In practical operation, there may be other dangerous states:

- machine movements
- vehicle movements
- electrical conductors
- visible or invisible radiation
- a combination of several risks and hazards

## 2.5 Environmental protection

The S200 safety laser scanner is constructed in such a way that it adversely affects the environment as little as possible and uses only a minimum of power and natural resources.

➤ At work, always act in an environmentally responsible manner.

### 2.5.1 Disposal

Unusable or irreparable devices should always be disposed as per the applicable national regulations on waste disposal (e.g. European waste code 16 02 14).

- Notes**
- We would be pleased to be of assistance on the disposal of this device. Contact your local SICK representative.
  - Information on the individual materials in the S200 is given in chapter 11 “Technical specifications” on page 68.

### 2.5.2 Separation of materials



WARNING

**Only appropriately trained personnel are allowed to separate materials!**

Caution is required when dismantling devices. There is a risk of injuries.

Before you send the devices for appropriate recycling, it is necessary to separate the different materials in the S200.

- Separate the housing from the rest of the parts (in particular the circuit boards).
- Send the separated parts for recycling as appropriate (see Tab. 1).

Tab. 1: Overview on disposal by components

Components	Disposal
Product	
Housing	Metal recycling (aluminium)
Motor bracket	Metal recycling (zinc die-cast housing)
Optics cover	Plastic recycling
Circuit boards, cables, connectors and electrical connecting pieces	Electronic recycling
Packaging	
Cardboard, paper	Paper/cardboard recycling
Polyethylene packaging	Plastic recycling

## 2.6 Applicable directives and standards

The most important directives and standards, valid for the use of opto-electronic protective devices in Europe, are listed below. Further regulations may be of importance to you, depending on the application. You can obtain further information of machine-specific standards from national institutions (e.g. DIN, BSI, AFNOR etc.), the authorities or your trade association.

If you operate the machine or vehicle in a country outside the European Union, please contact the manufacturer of the plant and the local authorities and obtain information on the regulations and standards applicable there.

### Application and installation of protective devices

Machinery Directive 2006/42/EC, e.g.:

- Safety of machinery – Basic concepts, general principles for design (EN ISO 12 100)
- Industrial automation systems – Safety of integrated manufacturing systems – Basic requirements (ISO 11 161)
- Safety of machinery – Electrical equipment of machines – Part 1: General requirements (IEC 60 204/EN 60 204)
- Safety of machinery – safety distances to prevent hazard zones being reached by the upper and lower limbs (EN ISO 13 857)
- Safety requirements for robots (EN ISO 10 218-1)
- Safety of industrial trucks. Driverless trucks and their systems (EN 1525)
- Safety of machinery – The positioning of protective equipment in respect of approach speeds of parts of the human body (EN ISO 13 855)
- Safety of machinery – Principles for risk assessment (EN ISO 14 121-1)
- Safety of machinery – Safety-related parts of control systems – Part 1: General principles for design (EN ISO 13 849-1) as well as Part 2: Validation (EN ISO 13 849-2)
- Safety of machines – electro-sensitive protective equipment – part 1: General requirements (EN 61 496-1) as well as part 3: Special requirements for AOPDDR (CLC/TS 61 496-3)
- Safety of machinery – Application of protective equipment to detect the presence of persons (IEC/TS 62 046)

Foreign standards, for example:

- Performance Criteria for Safeguarding (ANSI B11.19)
- Machine tools for manufacturing systems/cells (ANSI B11.20)
- Safety requirements for Industrial Robots and Robot Systems (ANSI/RIA R15.06)
- Safety Standard for guided industrial vehicles and automated functions of named industrial vehicles (ANSI B56.5)

**Recommendation** Please request our brochure on this subject “Safe Machines with opto-electronic protective devices”.

## 3 Product description

This chapter provides information on the special features and properties of the S200 safety laser scanner. It describes the construction and the operating principle of the device.

Please read this chapter before mounting, installing and commissioning the device.

### 3.1 Device components

The S200 safety laser scanner comprises three components:

- the sensor with the opto-electronic acquisition system, the LEDs and the 7-segment display
- the optics cover with the window for the light output
- the system plug with the configuration memory (the system plug contains all electrical connections)
- the system plug with all electrical connections

Fig. 1: Device components

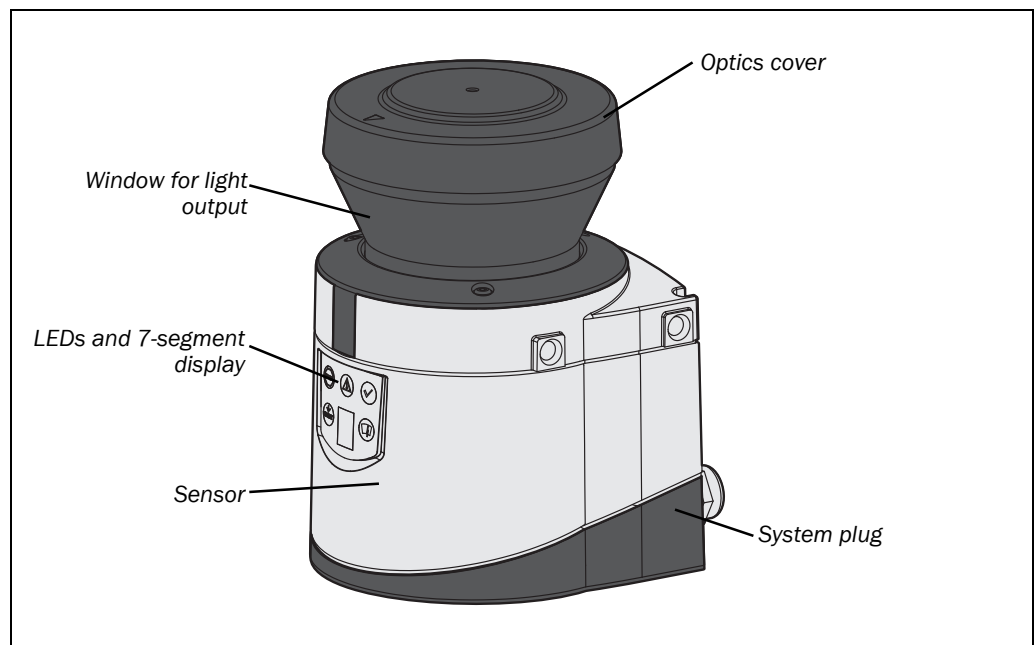

### 3.2 Special features

- 270° scanning angle
- the surrounding contour can be monitored (contour change can e.g. be the opening of a door to the outside)
- integrated external device monitoring (EDM)
- integrated restart interlock/restart interlock delay for which the parameters can be set
- status display with LEDs and 7-segment display
- minimum response time 80 ms
- configuration using PC or notebook with SICK Configuration & Diagnostic Software
- increased resilience to external light and dust due to highly effective dazzle and particle algorithms

#### S200 functions

Tab. 2: Functions of the S200

Functions	
Protective field range (radius)	1.5 m
Warning field width <sup>1)</sup>	8 m
Object resolution	30/40/50/70 mm
Field sets	1
Programmable monitoring cases	1
Pairs of output signal switching devices (OSSDs)	1
Source switching current of the OSSDs	250 mA
Application diagnostic output "Warning field interrupted"	■
Application diagnostic output "Error/contamination"	■
Application diagnostic output "Reset required"	■
External device monitoring (EDM)	■
Restart interlock/delay	■
Stand-by mode	■

### 3.3 Function

The S200 safety laser scanner operates correctly as a protective device only if the following conditions are met:

- The control of the machine, system or vehicle must be electrical.
- After integration in the control it must be possible to transfer the dangerous machine, system or vehicle state to a safe state using the OSSDs on the S200 at any time, i.e. before a person has reached the hazardous point or hazardous area.
- The S200 must be mounted and configured such that it detects objects as they enter the hazardous area (see chapter 4 "Mounting" on page 30 and chapter 8 "Commissioning" on page 53).

<sup>1)</sup> Warning field range with a reflectivity of 30% (see Fig. 41 "Diagram of scanning ranges for various reflectances" on page 64).

### 3.3.1 Principles of operation

The S200 is an optical sensor that scans its surroundings in two dimensions using infrared laser beams. It is used to monitor hazardous areas on machines or vehicles.

Fig. 2: Principle of operation, time of flight measurement by the S200

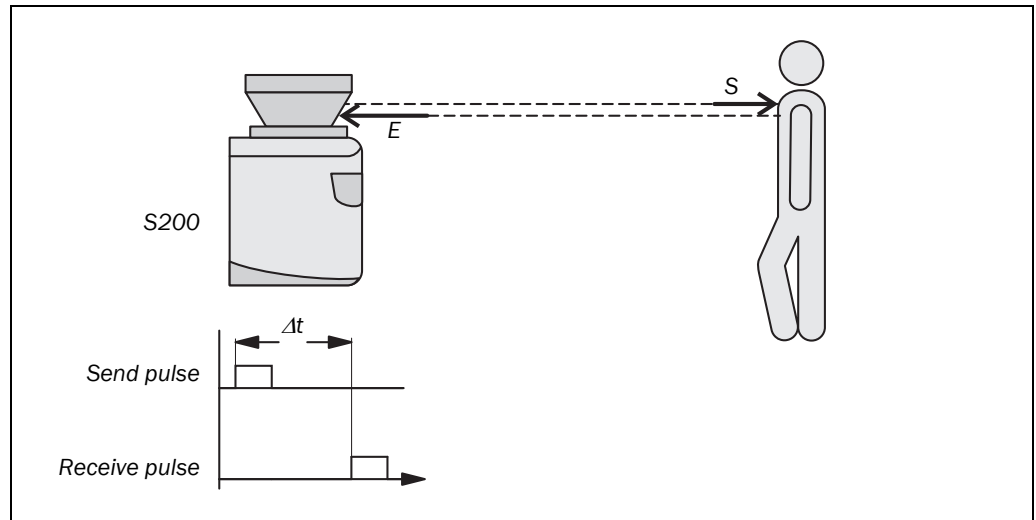

The S200 works on the principle of time of flight measurement. It sends out very short pulses of light (S). At the same time an “electronic stopwatch” is started. When the light is incident on an object, it is reflected and received by the safety laser scanner (E). From the time between sending and reception ( $\Delta t$ ) the S200 calculates the distance to the object.

Fig. 3: Principle of operation, rotation of the S200

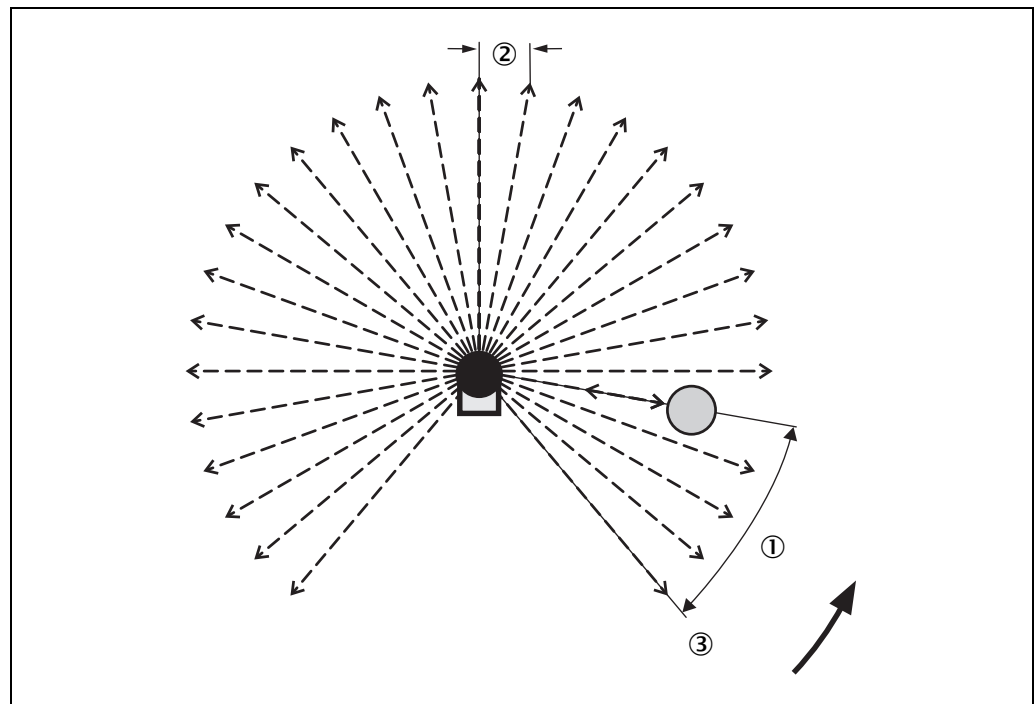

In the S200 there is also a mirror rotating at constant speed that deflects the light pulses such that they cover an arc of  $270^\circ$  ①. In this way an object can be detected in the protective field within  $270^\circ$ . The first beam ③ of a scan starts at  $-45^\circ$  relative to the back of the scanner.

The S200 sends a pulse of light with an angular resolution of  $0.5^\circ$ . In this way resolutions from 30 to 70 mm can be achieved independent of the length of the protective field ②!



Due to its active scanning principle, the S200 does not require receivers or reflectors. This has the following advantages:

- Your installation effort is lower.
- You can easily adapt the monitored area to the hazardous area on a machine.
- In comparison with contact sensors, electro-sensitive scanning is nearly wear-free.

### 3.3.2 Field set comprising of protective field and warning field

Fig. 4: Protective field, warning field and distance measuring range

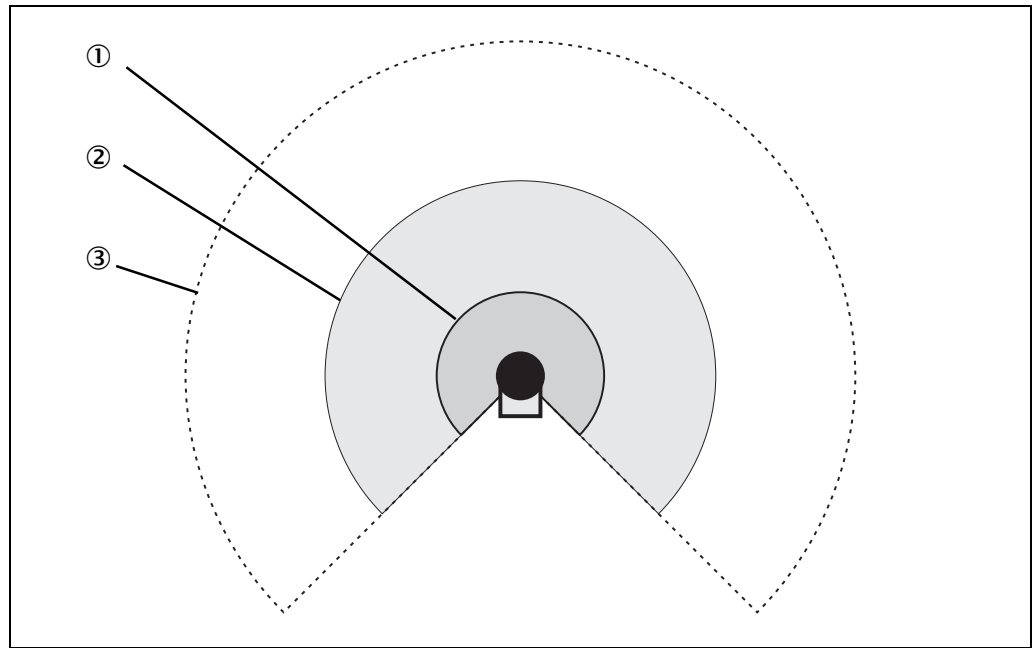

The S200 protects the hazardous area on a machine or a vehicle using the protective field ①. As soon as the safety laser scanner detects an object in the protective field, it switches the OSSDs to the OFF state and thus initiates the shutdown of the machine or stop of the vehicle.

You can define the warning field ② such that the safety laser scanner detects an object before the actual hazardous area and e.g. triggers a warning signal.

The maximum distance at which the safety laser scanner can detect an object is defined by the distance measuring range ③.

Protective field and warning field form a pair, the so-called field set.

With the aid of the CDS you can configure the field set and transfer it to the S200. If the hazardous area to be monitored changes, then you can re-configure the S200 in software without additional mounting effort.

## 3.4 Applications

### 3.4.1 Stationary applications

#### Hazardous area protection

Fig. 5: Hazardous area protection with one monitored area

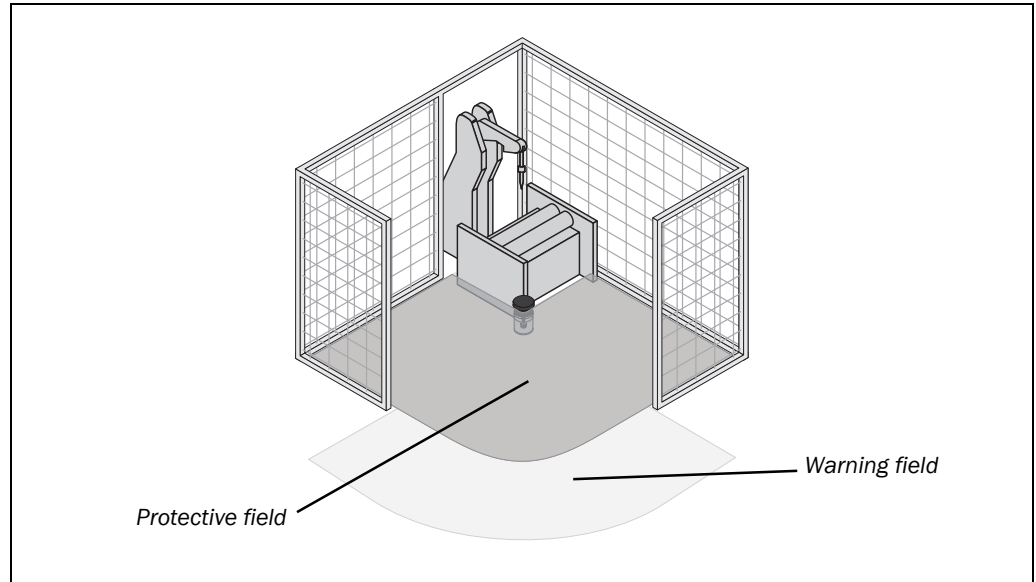

On stationary machines, the S200 switches the output signal switching devices (OSSDs) to the OFF state if the protective field is interrupted. The S200 initiates the shutdown of the machine or the shutdown of the dangerous state.

**Point-of-operation guarding**

The S200 safety laser scanner can be used to prevent starting or restarting as long as there are persons in the hazardous area. The machine can only be started or restarted if the S200 does not detect any object in the protective field. This is particularly important for system interiors that can only be seen with difficulty from the outside, or cannot be seen at all.

Fig. 6: Point-of-operation guarding

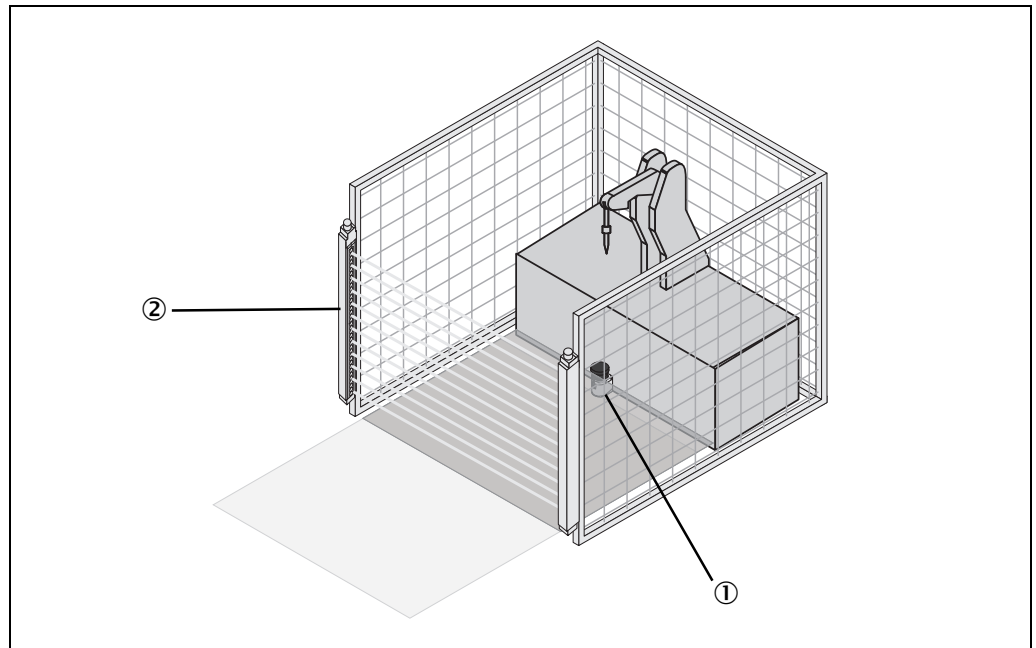

In this application the S200 ① does not have a stop function. The primary protective function that stops the dangerous movement is provided in the example by a light curtain ②, while the S200 monitors the restarting of the machine.

**Hazardous point protection (vertical operation)**

The S200 can be used vertically to trigger stopping of the dangerous movement. Compared to horizontal protection, the area to be protected in front of the machine or system can be reduced. Hazardous point protection is necessary if the operator is near the dangerous state of the machine. Hand protection is required to protect the hazardous point.

Fig. 7: Hazardous point protection

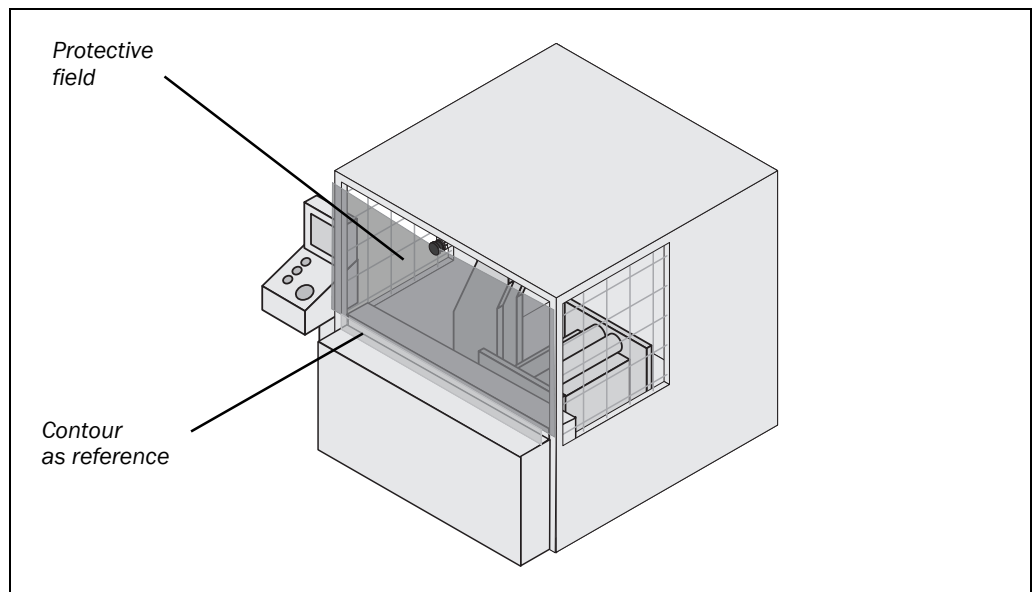

**Access protection (vertical operation)**

Fig. 8: Access protection

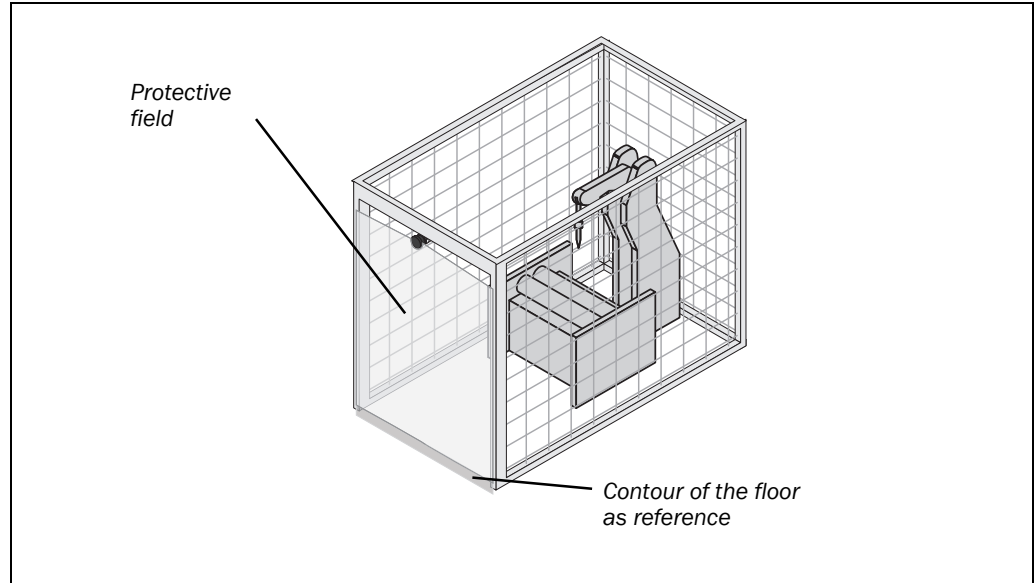

You can also use the S200 vertically for access protection. Access protection can be used when the access to the machine can be defined by physical means. In the case of access protection, the S200 detects the entry of a person, but not presence in the hazardous area (no point-of-operation protection).

**3.4.2 Mobile applications**

The S200 can be used both on manually controlled vehicles, e.g. fork lift trucks, and also on automated guided vehicles (AGV) or trolleys.

You can use the S200 on vehicles, e.g. to protect the route of a vehicle through a factory building. If there is a person or an obstacle in the hazardous area, the S200 ensures that the vehicle reduces the velocity and stops if necessary.

**Note** The safety level of the S200 corresponds to category 2 according to EN ISO 13849-1. It is only allowed to be used in corresponding applications.

## 3.5 Configurable functions

### 3.5.1 Field set

#### Configuration of the protective field and warning field



With the aid of the CDS you can configure the field set, which comprises a protective field and a warning field. During this process you configure the shape and size of the protective field and the warning field. You can realise any field shape required.

**Note** The area to be monitored is scanned radially by the S200. The S200 cannot see through objects during this process. The area behind objects that are in the area to be monitored (pillars, grilles, etc.) can thus not be monitored.

Protective field and warning field can cover up an angle of up to 270° and have different radial scanning ranges depending on the resolution configured (see Tab. 3 on page 23).



WARNING

#### Check the configured protective field!

Prior to commissioning the machine or vehicle, check the configuration of the protective field using the instructions in chapter 8 “Commissioning” on page 53 and using the checklist on page 80.

### Protective field or warning field suggested by the safety laser scanner

The CDS can suggest the protective field or warning field. The safety laser scanner scans the visible room contour several times. From the data obtained the CDS suggests the contour and size of the field.

Fig. 9: Reading protective field or warning field

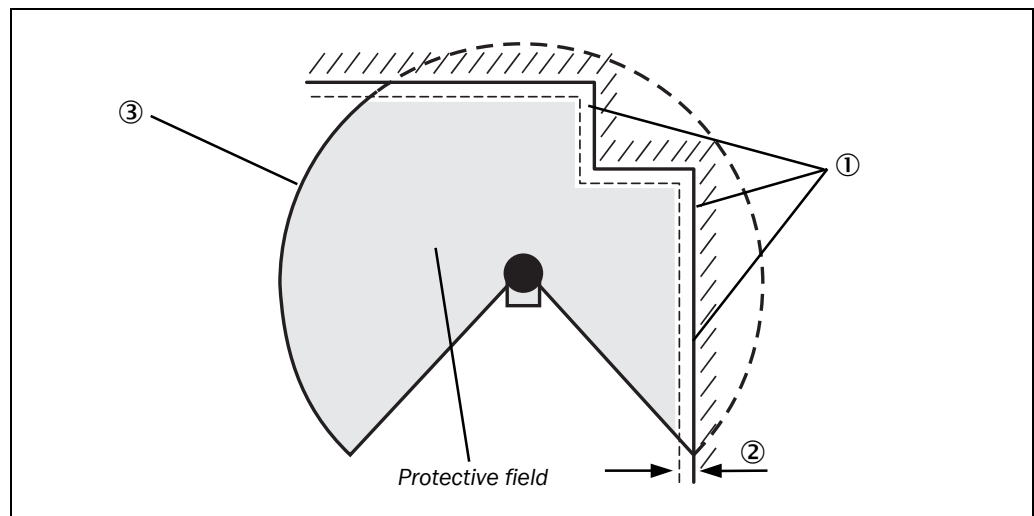

In those places at which the room contour is smaller than the maximum protective field range (e.g. at ①), the protective field corresponds to the room contour.

**Note** The measuring error tolerances for the S200 are automatically subtracted from the protective field size. As a result the protective field is slightly smaller than the surface covered ②.

In those places where the room contour is larger than the protective field range ③, the protective field corresponds to the possible scanning range (see Tab. 3 on page 23).



WARNING

#### Check the protective field suggested!

The protective field suggested by the CDS is not a replacement for the calculation of the safety distance. Calculate the safety distance based on the description in chapter 4 “Mounting” on page 30. Prior to commissioning the application, check the configuration of the protective field using the instructions in chapter 8 “Commissioning” on page 53 and using the checklist on page 80.



In the CDS field set editor, you can also request a suggestion for the protective field.

**S200**

**3.5.2 Application and resolution**



With the aid of the CDS you can configure the S200 for use on a stationary or mobile application. Also set the resolution of the S200.

The maximum protective field range depends on the resolution set. The following table shows the related maximum protective field range at the resolutions that can be set:

Tab. 3: Maximum protective field ranges at different resolutions

Resolution	Maximum protective field range
30 mm	1.25 m
40, 50, 70 mm	1.5 m

**Notes**

- The maximum protective field range of the S200 must be sufficient to cover the calculated protective field size including the necessary supplements (see section 4.1.1 “Protective field size” on page 31).
- The warning field can be configured to up to 8 m for all resolutions. The detection capability of the warning field is dependent on the remission of the objects to be detected (see Fig. 41 “Diagram of scanning ranges for various reflectances” on page 64).

**3.5.3 Using the contour as a reference**

In addition to the protective field, the S200 can also monitor a contour (e.g. the floor in vertical applications or the walls in horizontal applications).

Fig. 10: Schematic diagram of contour as reference

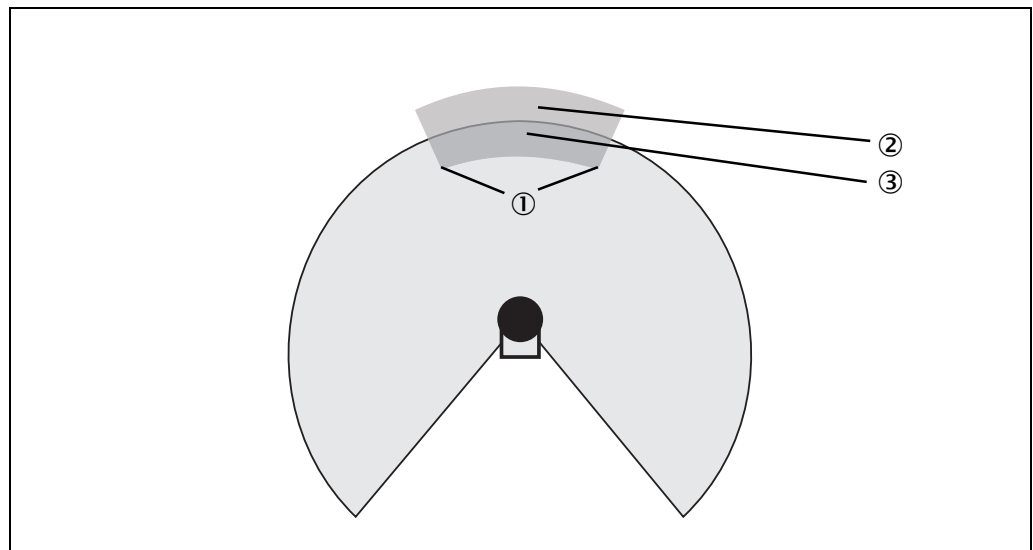

For contour monitoring you define a contour segment ①. The contour segment comprises a positive ② and a negative ③ tolerance band.

The OSSDs on the S200 change to the OFF state if ...

- there is an object in the protective field.
- the monitored surrounding contour is no longer in the tolerance band (e.g. if a door is opened or if the position of the S200 is changed).

**Note**

You can define any number of contour segments. The contour segments must not be narrower than the configured resolution. At the points where a contour has been configured as a reference you cannot define a warning field.



You define the contour as a reference in the CDS field set editor.

### Vertical operation

In vertical operation (for access protection and hazardous point protection) according to CLC/TS 61496-3 you must always configure the protective field with the contour as reference function.

Fig. 11: Contour as reference for vertical operation

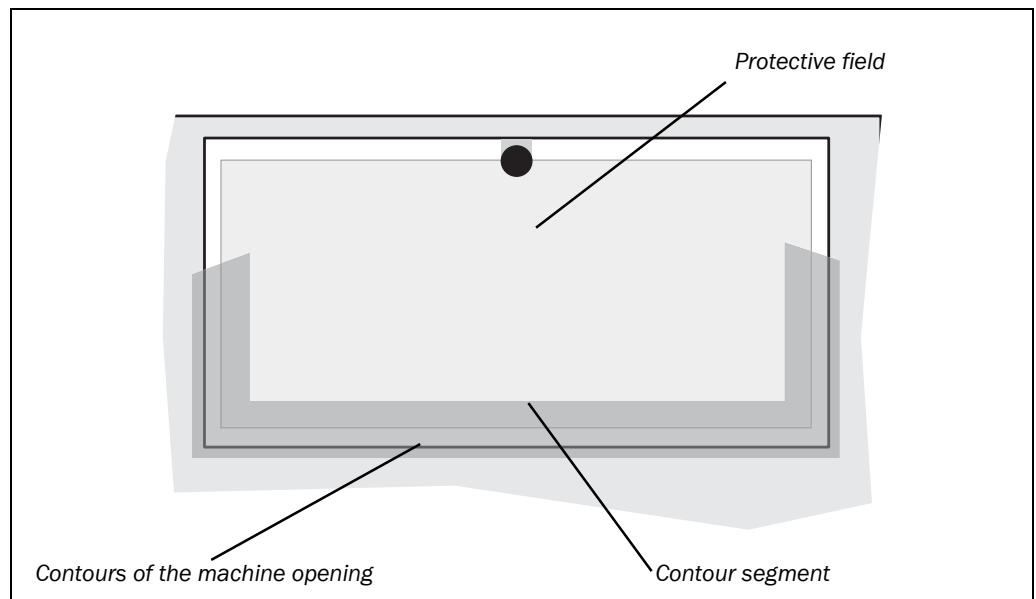

**Recommendation** Use lateral, vertical boundaries of the opening (e.g. door frame) and the floor as reference. If in this case the position of the S200 is changed in one or more planes, the distance to the reference changes and the S200 switches its OSSDs to the OFF state.

### Horizontal operation

On horizontal operation, you can also use the contour as reference function, e.g. so that if a door is opened (change to the room contour) the OSSDs on the S200 are placed in the OFF state.

Fig. 12: Contour as reference for horizontal operation

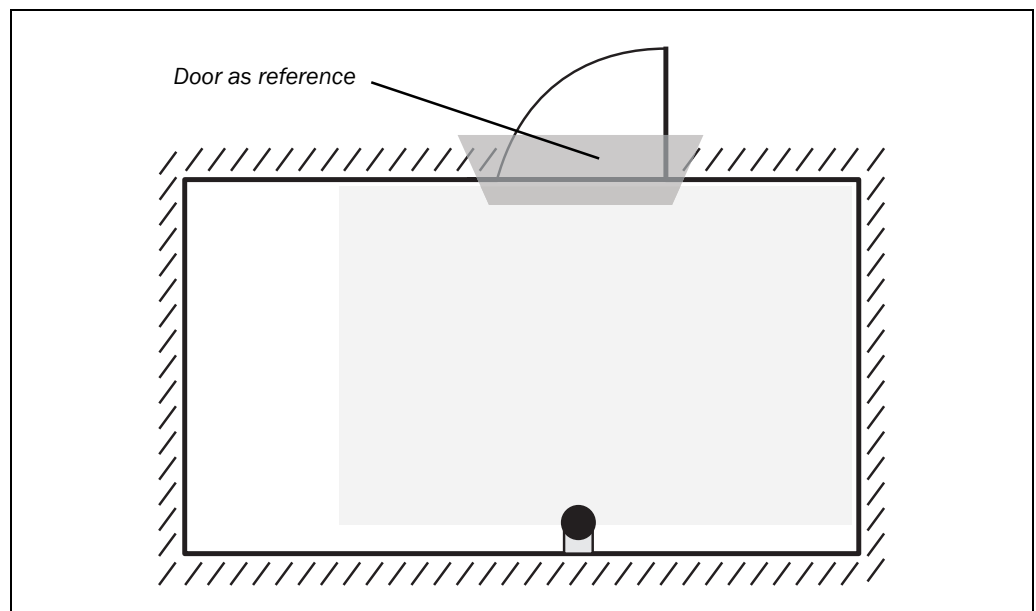





**3.5.4 External device monitoring (EDM)**

After every interruption to the protective field and prior to restarting the machine, the external device monitoring monitors the switching devices operated by the OSSDs (e.g. contactors). In this way the external device monitoring detects whether, e.g. the (positively guided) contacts on the contactors connected are in the OFF position.

The machine is only allowed to start if both contactors were in the OFF position before, that is they were deactivated.

The table shows how the S200 reacts if the external device monitoring detects a contactor malfunction:

Tab. 4: Behaviour of the S200 on a contactor malfunction

<b>Without</b> internal restart interlock	<ul style="list-style-type: none"> <li>• The system locks completely (lock-out).</li> <li>• The error message  appears in the 7-segment display.</li> </ul>
With restart interlock	<ul style="list-style-type: none"> <li>• The S200 switches its OSSDs to the OFF state.</li> <li>• The LED  is illuminated.</li> <li>• The error message  appears in the 7-segment display.</li> </ul>



**Notes**

You can configure the external device monitoring in the CDS.

- You will find examples on the connection of the external device monitoring in section 6.2 “Connection diagrams” on page 51.
- If you do not use the external device monitoring function, leave the inputs disconnected (see section 5.1.1 “Pin assignment on the system plug” on page 47).

**3.5.5 Application diagnostic output “Error/contamination”**



The S200 has a configurable application diagnostic output. The following configuration features are available in the CDS:

- window for light output contaminated
- error
- window for light output contaminated or error
- inactive

**3.5.6 Restart**

You can configure the restart behaviour of the S200 as follows:

- without restart interlock
- with restart delay
- with restart interlock



**WARNING**

**It is imperative that you configure the S200 with restart interlock if the protective field can be left to approach the hazardous point or if a person cannot be detected at every point in the hazard area for the S200!**

During the assessment, pay attention to whether the protective field can be left in the direction of the hazardous point, to areas that are unprotected due to the mounting and the unprotected near range of the S200 (see section 4.5 “Methods of preventing unprotected areas” on page 39).

### Configuration of the S200 without restart interlock

After the OSSDs on the S200 have been switched to the OFF state due to an object in the protective field, the OSSDs are re-enabled again immediately when there is no longer an object in the active protective field.

This configuration is only allowed ...

- if an external restart interlock is realised on the machine controller  
or
- if the protective field **cannot** be left in the direction of the hazardous point and if people can be detected by the S200 **at every point in the hazardous area!**

### Restart delay for mobile applications

In mobile applications you can configure a restart delay from 2 to 60 seconds on the S200. The OSSDs on the S200 change to the ON state if there is no object in the protective field for the duration given.

This configuration is only allowed if the protective field **cannot** be left in the direction of the hazardous point and if a person can be detected by the S200 **at every point in the hazardous area!**

### Configuration of the S200 with restart interlock

Fig. 13: Schematic outline of the operation with restart interlock

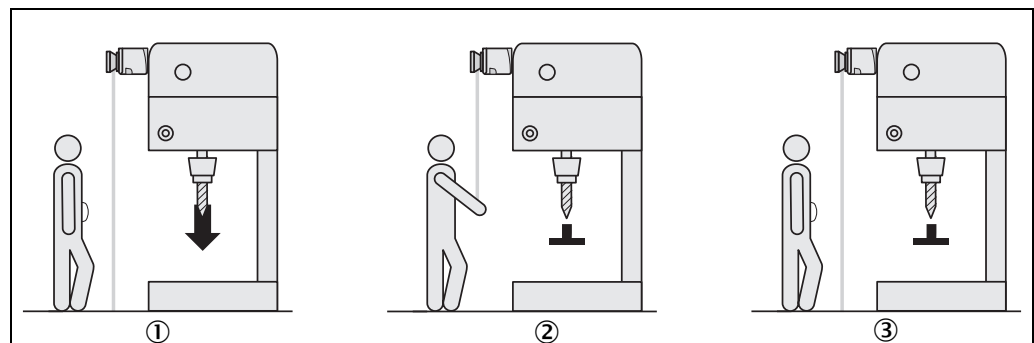

The OSSDs on the S200 change to the OFF state to trigger a machine ① or vehicle stop as soon as there is an object in the protective field ②. They do not change to the ON state ③, even if there is no longer an object in the protective field. The OSSDs only change to the ON state if the operator operates the control switch for restart or reset.



WARNING

### Place the control switch for restart or reset in a suitable place!

Place the control switch for restart or reset outside the hazardous area such that it cannot be operated by a person in the hazardous area. Ensure that the person who operates the control switch has a full view of the hazardous area.

**S200**

**Reset**

**Note** The reset function is often also called “preparation for restart”. In these operating instructions the term **reset** is used.

If you want to activate the restart interlock on the S200 (internal) and also a restart interlock on the machine (external), then each restart interlock has its own control switch. After operating the control switch for the internal restart interlock (with protective field unoccupied) ...

- the S200 switches its OSSDs to the ON state.
- the LED  on the safety laser scanner illuminates green.

The external restart interlock prevents the machine from restarting. After resetting the S200 the operator must press the control switch to restart the machine controller.



WARNING

**Ensure that the correct sequence is followed!**

The controller must be realised such that the machine only restarts if the S200 is first reset and then the control switch for restarting the machine controller is operated.

**Notes**

- You will find examples on the connection of the internal restart interlock in chapter 6.2 “Connection diagrams” on page 51.
- If you do not use the internal restart interlock, leave the inputs disconnected (see section 5.1.1 “Pin assignment on the system plug” on page 47).



You can configure the type of restart in the CDS.

**3.5.7 Multiple sampling**

If multiple sampling is set, an object must be scanned several times before the S200 switches its OSSDs to the OFF state. In this way you can reduce the probability that welding sparks, insects or other particles, result in the shutdown of the plant.

If a multiple sampling of 3 is configured, for instance, an object must be detected three times in succession before the S200 switches the OSSDs to the OFF state.



WARNING

**The total response time is increased by the multiple sampling!**

With a multiple sampling greater than 2, note that you must add a supplement to the basic response time (see section 11.2 “OSSD response times” on page 64)!

On the S200, a multiple sampling of 2 is the minimum setting. You can set the multiple sampling to up to 16 with the aid of the CDS.

Tab. 5: Recommended multiple sampling

Recommended multiple sampling	Application
2 times	Stationary under clean ambient conditions
2 ... 4 times	Mobile
4 ... 8 times	Stationary under dusty ambient conditions

**Recommendation**



Using multiple sampling you can increase the availability of a plant.

You can configure multiple sampling in the CDS.

### 3.5.8 Stand-by mode

If, in mobile applications, vehicles are not moved for a time, the OSSDs and the laser on the S200 can be switched off. In this way the power consumption of the device is reduced.

#### Recommendation

Use this function if, e.g. you use several vehicles and do not move them for a time.

A dedicated *STBY* single-channel input is provided for switching to the stand-by mode (see section 5.1.1 “Pin assignment on the system plug” on page 47).

### 3.5.9 Naming applications and laser scanners

A name can be assigned to the application configured and to the laser scanner(s). The names are saved in the devices after the configuration is transferred. The name chosen may be, for example, the identifier for the vehicle, system or the machine.



You enter the application name and the name of the laser scanner used in the CDS.

## 3.6 Indicators and outputs



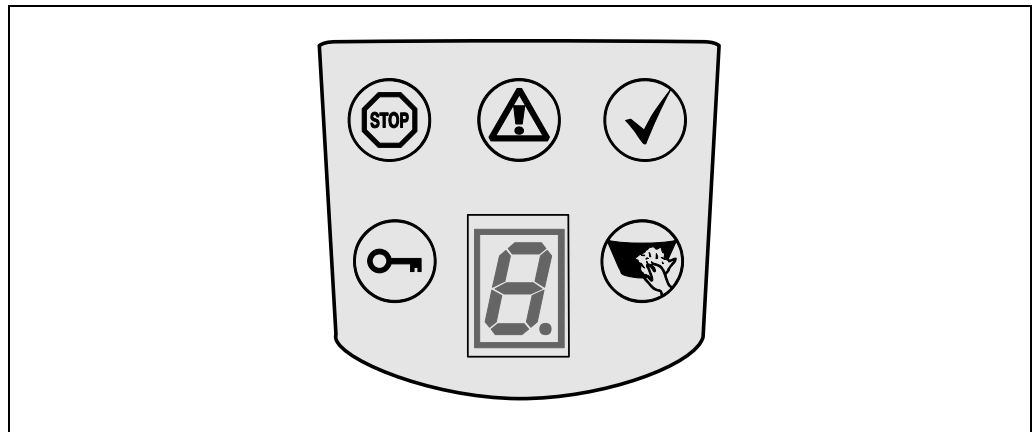

### 3.6.1 LEDs and 7-segment display

The LEDs and the 7-segment display indicate the operational status of the S200. They are on the front face of the safety laser scanner.

Fig. 14: Status indicators on the S200



The symbols have the following meaning:

-  OSSDs in the OFF state (e.g. in case of object in the protective field, monitored contour changed, reset required, lock-out)
-  Warning field interrupted (object in warning field)
-  OSSDs in the ON state (no object in protective field)
-  Reset required
-  Optics cover contaminated

**3.6.2 Outputs**

Using the outputs on the S200 you shutdown the dangerous state on a machine, a plant or a vehicle and evaluate the operational status of the S200. The S200 has the following outputs:

- OSSDs
- application diagnostic output “Warning field interrupted”
- application diagnostic output “error/contamination”
- application diagnostic output “Reset required”

The outputs are fed out at the system plug (see section 5.1 “System connection” on page 47).

**Note** All outputs are only allowed to be used for the purpose specified. Note that the signals at the application diagnostics outputs for “warning field”, “contamination of the optics cover/error” and “reset required” are single-channel and therefore are not allowed to be used for tasks related to safety. For this reason the warning field is not allowed to be used for tasks related to personnel protection.

## 4 Mounting

This chapter describes the preparation and completion of the mounting of the S200 safety laser scanner. Mounting requires three steps:

- definition of the application and the necessary mounting location for the laser scanner
- calculation of the protective field size
- mounting the safety laser scanner with or without mounting kits



WARNING

### No protective function without sufficient safety distance!

Only if you configure the protective field such that there is an adequate safety distance to the hazardous area, is protection by the S200 ensured.

#### Notes

- Mount the S200 in a dry place and protect the device from dirt and damage.
- Avoid the installation of the S200 in the vicinity of strong electric fields. These can, e.g., be produced by welding cables, induction cables in the immediate vicinity and also by mobile telephones operated nearby.
- Ensure that there are no obstacles in the area to be monitored in the field of view of the S200 that could cause interference or shadowing. Such shadowed areas cannot be monitored by the S200. If there are unavoidable shadowed areas, check whether there is a risk. Take additional safety precautions as necessary.
- Keep the area to be monitored free of smoke, fog, steam or other forms of air impurities. There must not be any condensation on the light output window. Otherwise the function of the S200 may be impaired and incorrect switching may occur.
- Avoid placing highly reflective objects in the scan plane of the S200. Examples: Retroreflectors can affect the measurement results of the S200. Strongly reflective objects within the protective field can blank part of the area to be monitored in certain circumstances.
- Mount the S200 such that it is not dazzled by incident sunlight. Do not position stroboscopic and fluorescent lights or other strong light sources directly in the scan plane as these may affect the S200 in specific circumstances.
- Mark the protective field on the floor, if appropriate for the application (see EN 61496-1, chapter 7).
- Add the general protective field supplement of 100 mm to each protective field size calculated. The maximum protective field range of the S200 must be sufficient to cover the calculated protective field size and the necessary supplements.

The following steps are necessary after mounting and installation:

- completing the electrical connections (chapter 5 “Electrical installation”)
- configuration of the protective field (chapter 7 “Configuration”)
- commissioning and checking of the installation (chapter 8 “Commissioning”)
- checking the function and safe shutdown (section 8.3 “Test notes”)

## 4.1 Stationary application in horizontal operation

This type of protective device is suitable for machines and systems on which, e.g. a hazardous area is not completely enclosed by a guard.

Fig. 15: Horizontal stationary application

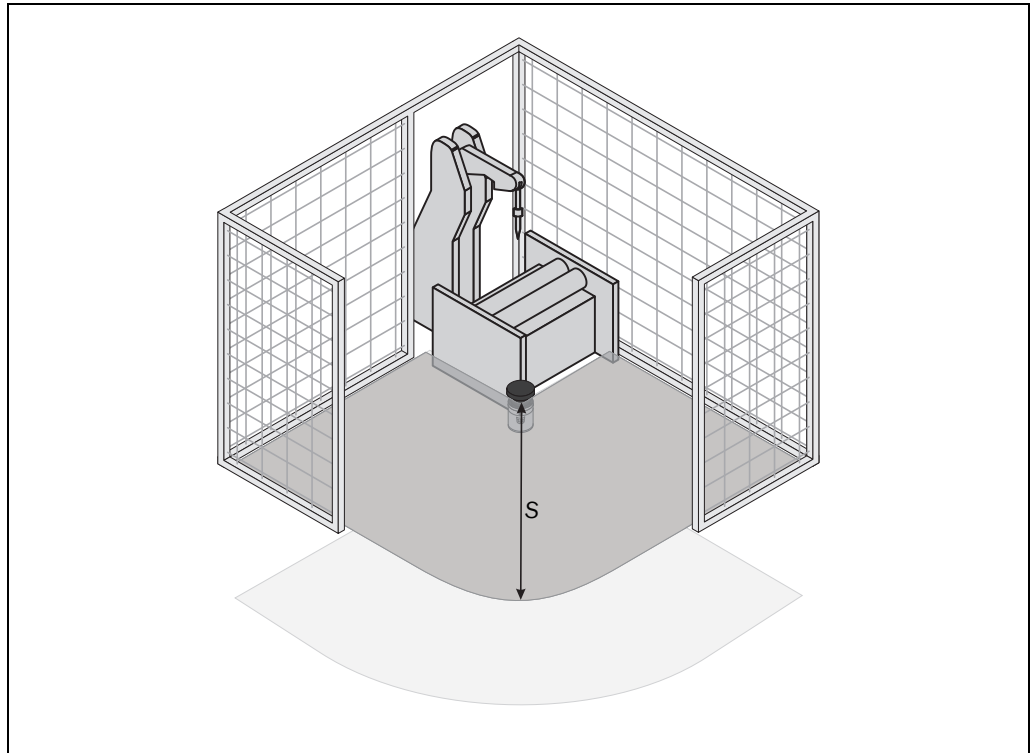

For a horizontal stationary application determine ...

- the protective field size to observe the necessary safety distance.
- the height of the scan plane.
- the restart behaviour.
- measures to protect any areas not covered by the S200.

**Note** Once you have defined the protective field size, mark the boundaries of the protective field on the floor. In this way you will make the protective field boundaries visible for the operator and ease subsequent testing of the shape of the protective field.

### 4.1.1 Protective field size

The protective field must be so configured that a safety distance (S) to the hazardous area is maintained. This safety distance ensures that the hazardous point can only be reached after the dangerous state of the machine has been completely stopped.

You can operate the S200 in stationary horizontal operation with 30, 40, 50 or 70 mm resolution. The maximum protective field range for the S200 is given by the resolution.



WARNING

#### Ensure that a human leg can be detected with 70 mm resolution!

As per EN ISO 13855, mount the scan planes for horizontal stationary applications with 70 mm resolution at least 300 mm above the floor (see “Height of the scan plane at 70 mm resolution” on page 34).

Fig. 16: Safety distance S

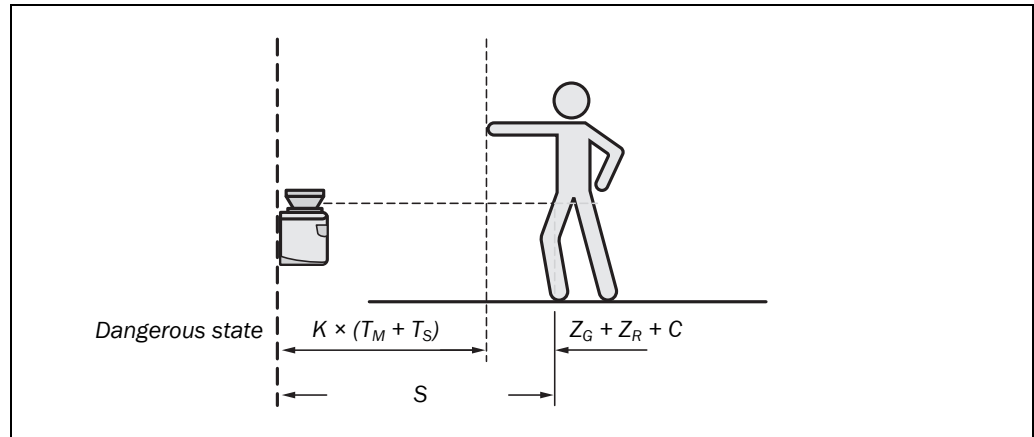
**The safety distance S depends on:**

- approach speed of the body or parts of the body
- stopping/run-down time of the machine or system  
(The stopping/run-down time is shown in the machine documentation or must be determined by taking a measurement.)
- response time of the S200
- supplements for general measurement errors and any measurement errors related to reflection
- supplement for prevention of reaching over
- height of the scan plane

**How to calculate the safety distance S:**

➤ First, calculate S using the following formula:

$$S = (K \times (T_M + T_S)) + Z_G + Z_R + C$$

Where ...

K = Approach speed (1600 mm/s, defined in EN ISO 13855)

$T_M$  = Stopping/run-down time of the machine or system

$T_S$  = Response time of the S200 and the downstream controller

$Z_G$  = General safety supplement of the S200 = 100 mm

$Z_R$  = Supplement for measurement error related to reflection

C = Supplement for prevention of reaching over

**Response time  $T_S$  of the S200**

The response time  $T_S$  of the S200 depends on ...

- the basic response time of the S200.
- the multiple sampling set.

See section 11.2 “OSSD response times” on page 64.

**Supplement  $Z_R$  for measurement error related to reflection**

WARNING

**Avoid mounting retroreflectors at a distance of less than one meter from the boundary of the protective field!**

With retroreflectors positioned at a distance of less than 1 m from the boundary of the protective field a supplement,  $Z_{Rv}$ , of 200 mm must be added to the protective field.



### Supplement C for protection against reaching over

With a protective field installed horizontally, there is a risk that people may reach over the protective field and in this way reach the hazardous area before the S200 shuts down the dangerous state. For this reason the calculation of the safety distance must take into account a supplement to prevent persons from finding themselves in a hazardous situation by reaching over (see EN ISO 13 857) before the S200 triggers.

The necessary supplement for the safety distance is dependent on the height of the scan plane for the protective field. At low heights ① the supplement is larger than at greater heights ② and ③.

Fig. 17: Mounting variations for the scan plane

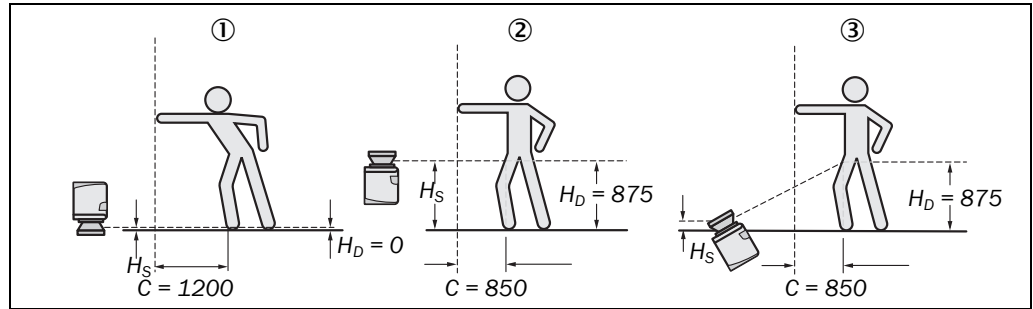

In summary there are three usual variations of mounting the scan plane for the S200. The optimal variation depends on the related application. Tab. 6 provides assistance making the selection.

Tab. 6: Advantages and disadvantages of mounting variations

Mounting orientation	Benefit	Disadvantage
Laser scanner low ( $H_S < 300$ mm) Inclination of the scanning plane low ( $H_D \approx H_S$ )	Low external effects due to dazzle, crawling beneath not possible	Higher supplement C
Laser scanner high ( $H_S > 300$ mm) Inclination of the scanning plane low ( $H_D \approx H_S$ )	Lower protective field supplement C	Danger of crawling beneath (at the front and side)
Laser scanner low ( $H_S < 300$ mm) Inclination of the scanner plane high ( $H_D > H_S$ )	Lower protective field supplement C	Danger of crawling beneath (at the front), external effect due to dazzle possible

$H_D$  = Detection height  
 $H_S$  = Scanner mounting height



WARNING

**In case of scan planes at a height of more than 300 mm ensure that people cannot reach the hazardous area by crawling underneath the scan plane!**

If you mount the protective device higher than 300 mm, you must prevent crawling beneath by means of additional measures. For applications that are accessible to the public, the mounting height may need to be reduced to 200 mm (on this subject see the appropriate regulations).

**How to calculate the supplement C:**

➤ If there is enough empty space in front of your machine or plant, use 1200 mm for the supplement C.

➤ If the safety distance is to be kept as small as possible, calculate C using the following formula:

$$C = 1200 \text{ mm} - (0.4 \times H_D)$$

Here  $H_D$  is the height at which the protective field is mounted.

**Note** The minimum supplement C to prevent reaching over is 850 mm (arm length).

**Height of the scan plane at 70 mm resolution**

Due to the radial sampling of the protective field, the optical resolution will be lower the further away you get from the safety laser scanner.

Fig. 18: Relationship between resolution and protective field mounting height

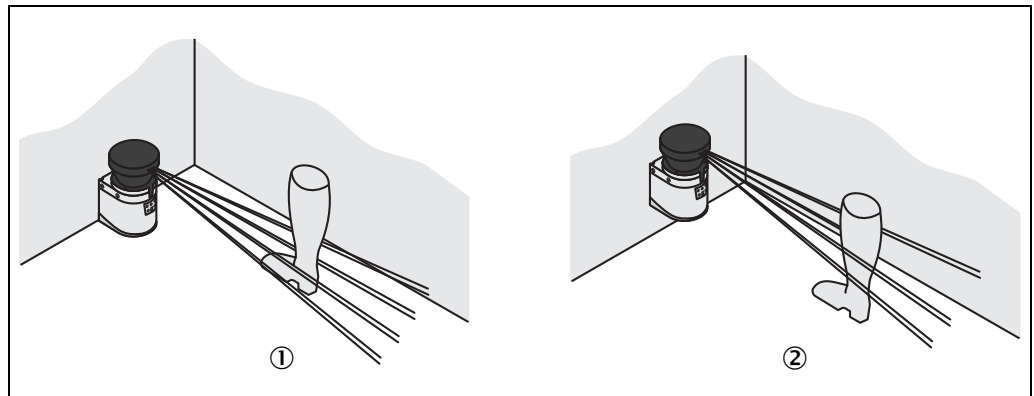

If you choose a resolution of 70 mm in the CDS for hazardous area protection, a human leg may, in certain circumstances, not be detected (e.g. scan to left and right of the bone ①).

If you mount the S200 higher, the scan plane is at fibula height and the leg is also detected with an object resolution of 70 mm ②.

## 4.2 Stationary vertical operation for access protection

Access protection can be used when the access to the machine can be defined by physical means. For access protection the S200 detects the entry of an entire body.

- Notes**
- To ensure adequate access protection, a response time of  $\leq 90$  ms and a resolution of 70 mm or finer are required.
  - To protect the protective device against unadvertent adjustment or manipulation, you must use the contour of the surroundings as a reference for the S200 (see section 3.5.3 “Using the contour as a reference” on page 23).

### 4.2.1 Safety distance

For access protection, a safety distance (S) must be maintained between protective field and hazardous area. This safety distance ensures that the hazardous point can only be reached after the dangerous state of the machine has been completely stopped.

Fig. 19: Access protection

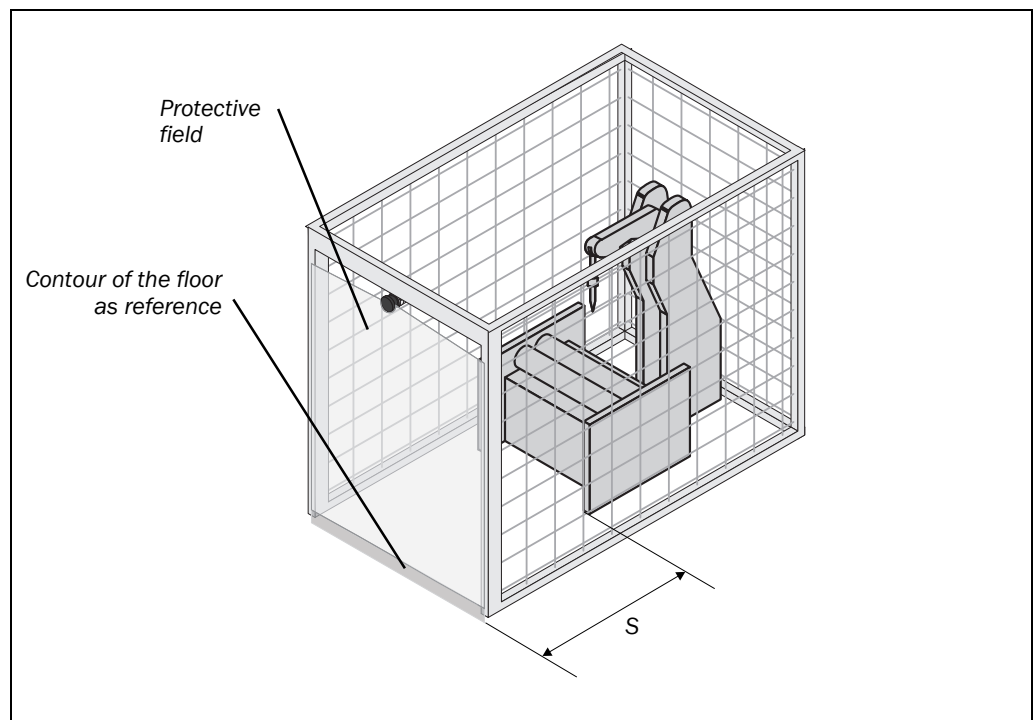

**The safety distance S as defined in EN ISO 13855 and EN ISO 13857 depends on:**

- reach or approach speed
- stopping/run-down time of the machine or system  
(The stopping/run-down time is shown in the machine documentation or must be determined by taking a measurement. On request SICK service can perform a detailed stopping/run-down measurement on your plant.)
- response time of the S200
- supplement C against reaching through

**How to calculate the safety distance S:**

➤ First, calculate S using the following formula:

$$S = (K \times (T_M + T_S)) + C$$

Where ...

K = Approach speed (1600 mm/s, defined in EN ISO 13855)

T<sub>M</sub> = Stopping/run-down time of the machine or system

T<sub>S</sub> = Response time of the S200

C = Supplement against reaching through (850 mm)

**Response time T<sub>S</sub> of the S200****WARNING****The total response time of the S200 must not be more than 80 ms for access protection!**

If a critical response time is exceeded (for an object diameter of 70 mm and a speed of 1.6 m/s that is 90 ms) a person may no longer be detected under certain circumstances.

In specific cases agreed with the responsible authorities higher response times may be allowed (for example by increasing the detection time available by positioning the scanner at an angle). In this case ensure that the areas the laser scanner cannot see are protected by additional measures.

The response time T<sub>S</sub> of the S200 depends on ...

- the basic response time of the S200.
- the multiple sampling set.

See section 11.2 “OSSD response times” on page 64.

### 4.3 Stationary vertical operation for hazardous point protection

Hazardous point protection is necessary if the operator must remain near the dangerous state of the machine. Hand protection is required for hazardous point protection.

**Note** The S200 must therefore be configured with a resolution of at least 40 mm.



WARNING

**Never use the S200 for safety applications in which finger protection is required!**

Due to the finest possible resolution of 30 mm, the S200 is not suitable for finger protection.

To protect the protective device against inadvertent adjustment or manipulation, you must use the contour of the surroundings as a reference for the S200 (see section 3.5.3 “Using the contour as a reference” on page 23).

#### 4.3.1 Safety distance

For hazardous point protection, a safety distance must be observed between protective field and hazardous point. This safety distance ensures that the hazardous point can only be reached after the dangerous state of the machine has been completely stopped.



WARNING

**Prevent reaching around or reaching behind the protective field!**

Always mount the laser scanner such that reaching around and behind is impossible. Provide suitable additional precautions as necessary.

Fig. 20: Safety distance to the hazardous area

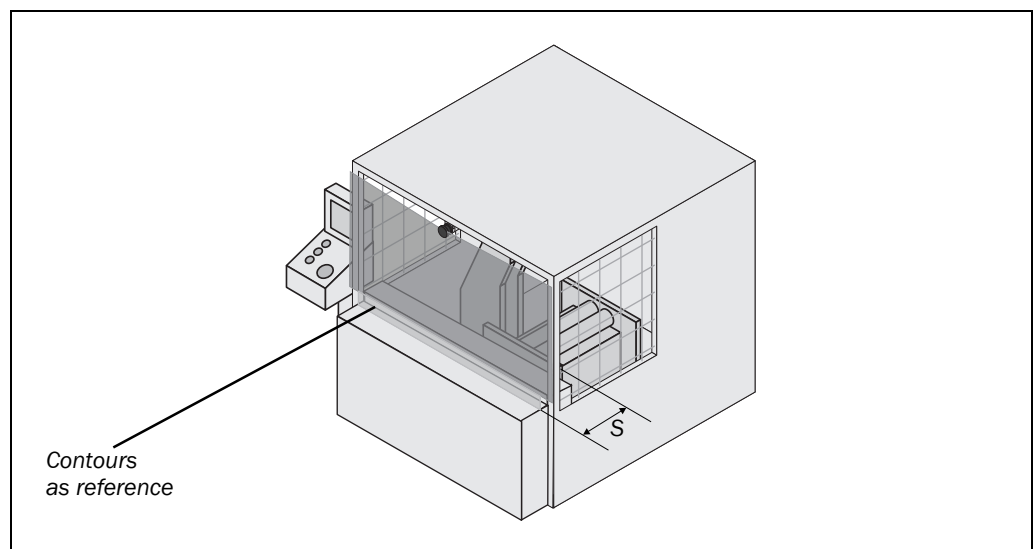

**The safety distance  $S$  as defined in EN ISO 13855 and EN ISO 13857 depends on:**

- stopping/run-down time of the machine or system  
(The stopping/run-down time is shown in the machine documentation or must be determined by taking a measurement.)
- response time of the S200
- reach or approach speed
- resolution of the S200

**How to calculate the safety distance S:**

➤ First, calculate S using the following formula:

$$S = 2000 \times (T_M + T_S) + 8 \times (d - 14 \text{ mm}) \text{ [mm]}$$

Where ...

S = Safety distance [mm]

$T_M$  = Stopping/run-down time of the machine or system

$T_S$  = Response time of the S200

d = Resolution of the S200 [mm]

**Note** The reach/approach speed is already included in the formula.

➤ If the result S is  $\leq 500$  mm, then use the determined value as the safety distance.

➤ If the result S is  $> 500$  mm, you may be able to reduce the safety distance using the following calculation:

$$S = 1600 \times (T_M + T_S) + 8 \times (d - 14 \text{ mm}) \text{ [mm]}$$

➤ If the new value S is  $> 500$  mm, then use the newly calculated value as the minimum safety distance.

➤ If the new value S is  $\leq 500$  mm, then use 500 mm as the minimum safety distance.

**Response time  $T_S$  of the S200**

The response time  $T_S$  of the S200 depends on ...

- the basic response time of the S200.
- the multiple sampling set.

See section 11.2 “OSSD response times” on page 64.

**4.4 Mobile applications**

If the dangerous state is produced by a vehicle (e.g. AGV or fork lift), the hazardous area that is produced by the movement of the vehicle is protected by the S200.

- Notes**
- The safety level of the S200 corresponds to category 2 according to EN ISO 13849-1. It is only allowed to be used in corresponding applications.
  - The S200 may only be used to protect vehicles powered by electric motor.
  - On automated guided systems the S200 is not allowed to be used to protect the main direction of travel.
  - For vehicle protection, observe EN 1525 “Safety of industrial trucks. Driverless trucks and their systems”.
  - If the application is to protect vehicles from collisions, then you may need to use different assumptions.

**4.5 Methods of preventing unprotected areas**

During mounting the S200, areas may be found that are not covered by the safety laser scanner (①).

Fig. 21: Unprotected areas

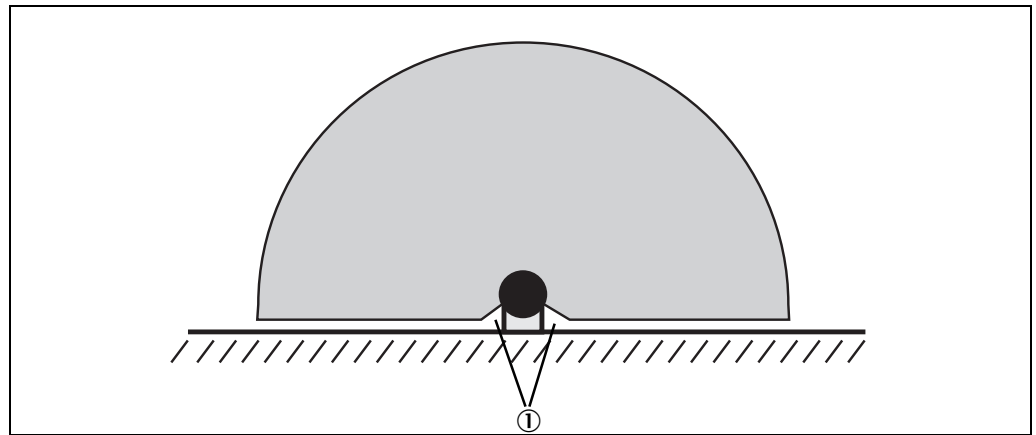

WARNING

**Prevent or secure unprotected areas!**

- Mount the S200 such that there are no unprotected areas.
- For mobile applications, if the vehicle is accelerated to a maximum velocity of 0.3 m/s in less than three seconds when in operation, you must prevent personnel from entering the unprotected areas by means of mechanical trim panels, switch strips or fitting the S200 in the vehicle trim panels.

Fig. 22: Preventing unprotected areas

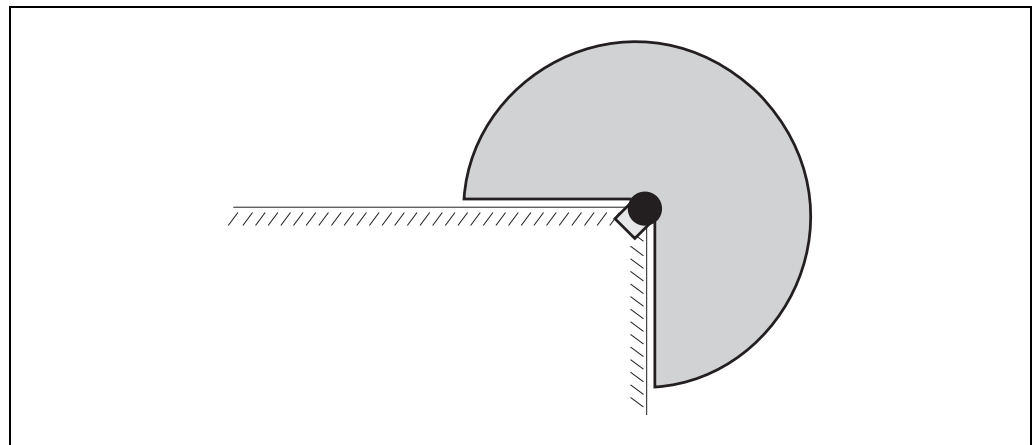

Mount the S200 for example on a corner to prevent unprotected areas.

**4.5.1 Near range**

Make the near range impassible using a bar or a recess, or additionally protect the near range (5 cm wide area in front of the optics cover) using a proximity switch with 5 cm acquisition range. The vehicle may then be accelerated as required.

## 4.6 Mounting steps



WARNING

### Special features to note during mounting:

- Mount the S200 such that it is protected from moisture, dirt and damage.
- Ensure that the entire field of view of the S200 is not restricted.
- Mount the laser scanner such that the indicators are easy to see.
- Always mount the S200 so that there is still enough space for mounting and removing the system plug.
- Avoid excessive shock and vibration loading on the safety laser scanner.
- On applications that suffer from heavy vibration, prevent the fixing screws from coming loose using screw locking devices.
- Regularly check the tightness of the fixing screws.
- Prevent personnel from being able to crawl beneath, stand behind or climb over the protective field by means of appropriate mounting of the S200.

Fig. 23: Prevent crawling beneath, standing behind, climbing over

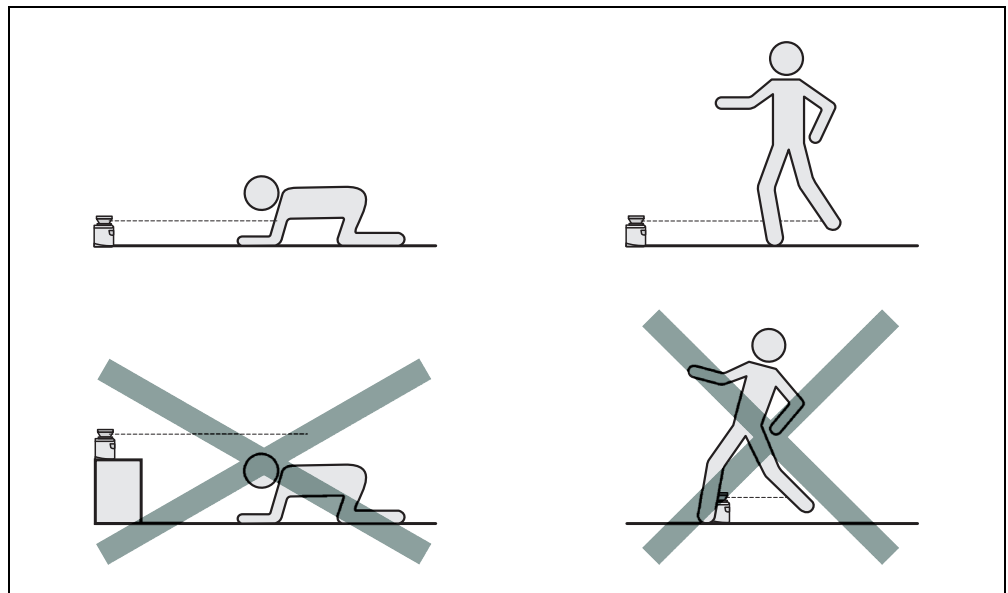

The origin of the scan plane is 116 mm above the bottom edge of the S200 (see section 11.5.3 “Scan plane origin” on page 76).

There are three possible ways of fixing the S200:

- direct mounting without mounting kit
- mounting with mounting kit 1a or 1b
- mounting with mounting kit 2 (only in conjunction with mounting kit 1a or 1b)

You will find the part numbers for the mounting kits in section 12.3.1 “Mounting kits” on page 77.

**Note** Pay attention to the maximum torque of the M5 fixing screws on the S200 of max. 5.9 Nm.



### 4.6.1 Direct mounting

The S200 has two threaded holes M5 × 8 on the rear. Using them you can mount the S200 directly on the intended mounting surface. To avoid a possible tendency to vibrate, if necessary the reference surface on the rear can be used as the third mounting point ①.

Fig. 24: Direct mounting

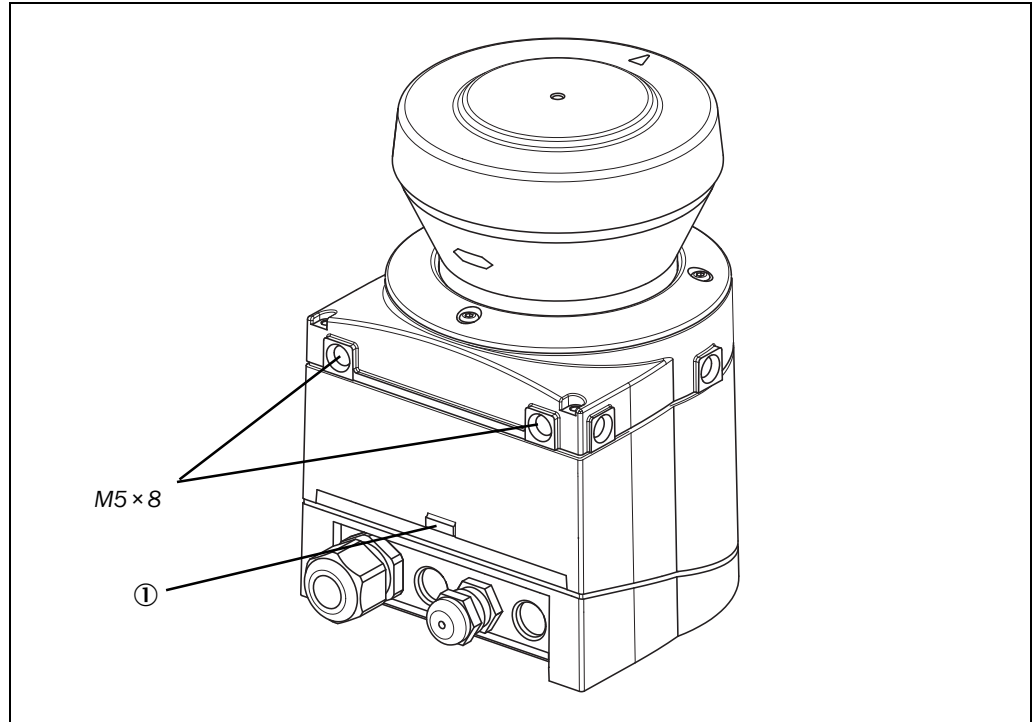

**Notes** During mounting, please observe the dimensional drawings in chapter “Technical specifications” (see section 11.5 “Dimensional drawings” on page 74).

### 4.6.2 Mounting with mounting kit 1a or 1b

With the aid of mounting kit 1 you can mount the S200 indirectly on the mounting surface. The mounting kit is available as mounting kit 1a without protection device for the optics cover and as mounting kit 1b with protection device for the optics cover.

Fig. 25: Mounting with mounting kit 1a

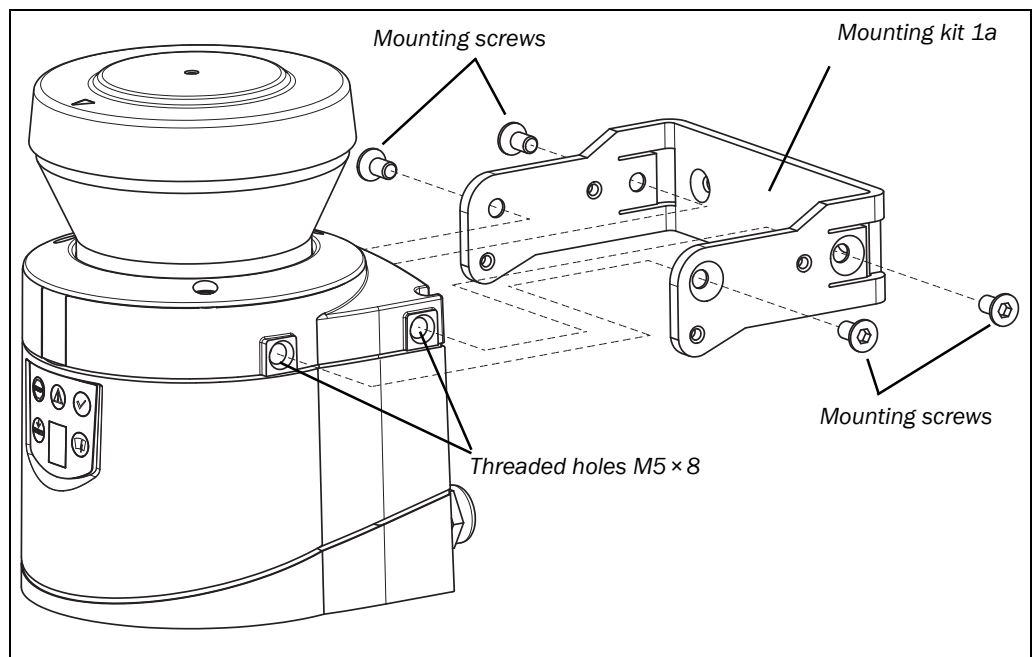
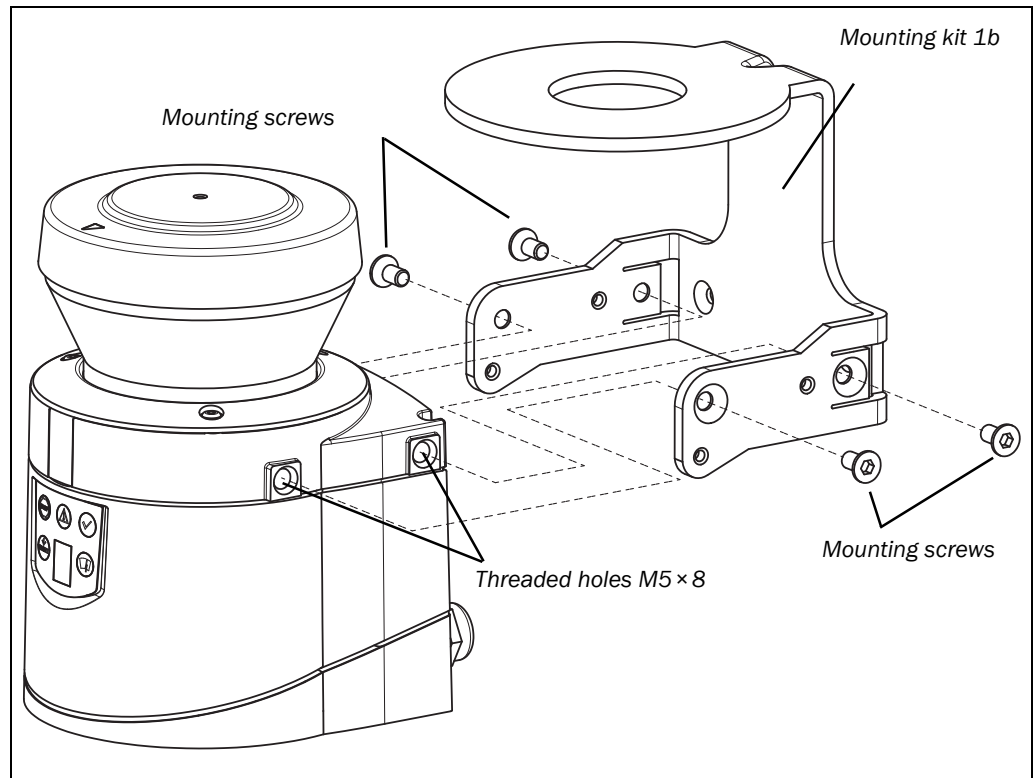

Fig. 26: Mounting with mounting kit 1b incl. protection for the optics cover



- Mount mounting kit 1a or 1b on the mounting surface.
- Then mount the S200 on the mounting kit 1a or 1b.

**Note** During mounting, please observe the dimensional drawings in chapter “Technical specifications” (see section 11.5 “Dimensional drawings” on page 74).

## S200

## 4.6.3 Mounting with mounting kit 2 and 3

With the aid of mounting kits 2 and 3 (only in conjunction with mounting kit 1a or 1b) you can align the S200 in two planes. The maximum adjustment angle is  $\pm 11^\circ$  in both planes.

Fig. 27: Mounting with mounting kit 2

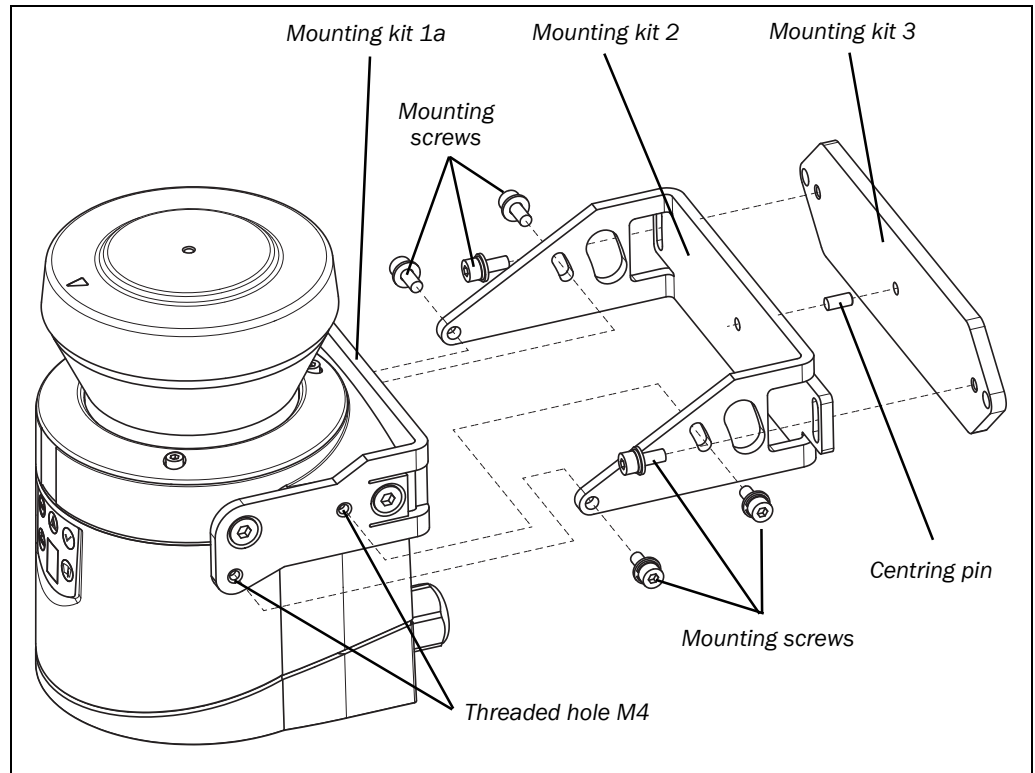

- Mount mounting kit 1a or 1b to the S200.
- Mount the mounting kit 3 on the mounting surface.
- Fit the centring pin (4 mm) in the central hole on mounting bracket 3.
- Fit mounting kit 2 to mounting kit 3 and mount it using two fixing screws M4 × 10.
- Then mount the S200 on mounting kit 2 with the aid of the threaded holes in mounting kit 1a.
- Adjust the S200 longitudinally and transversely and then tighten the six fixing screws on the mounting kits.

**Note** During mounting, please observe the dimensional drawings in chapter “Technical specifications” (see section 11.5 “Dimensional drawings” on page 74).

## 4.6.4 Information label Important information

- On completion of mounting, you must affix the self-adhesive information label **Important information** supplied:
  - Use only the information label in the language which the operators of the machine can read and understand.
  - Place the information label such that it is clearly visible for the operators during operation. The information label must not be covered even after additional items have been mounted.

#### 4.6.5 Using multiple S200 safety laser scanners

The S200 is so designed that mutual interference between several laser scanners is unlikely. To completely exclude erroneous switching, you must mount the laser scanners as shown in the following examples.

**Note** In any circumstance observe EN ISO 13855 when calculating the safety distance. Use mounting kits 1 and 2 to adjust the laser scanners to different angles (see section 12.3.1 “Mounting kits” on page 77).

Fig. 28: Opposite mounting

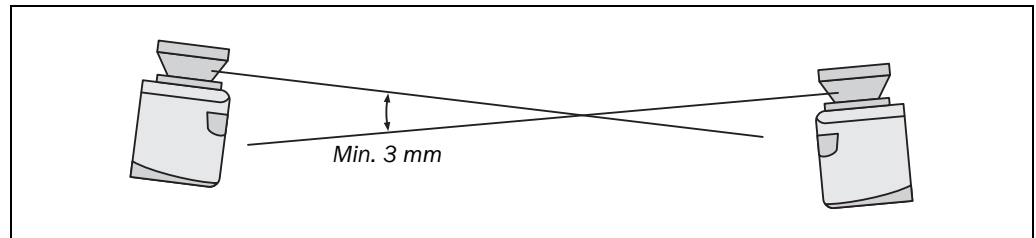

Fig. 29: Offset parallel mounting

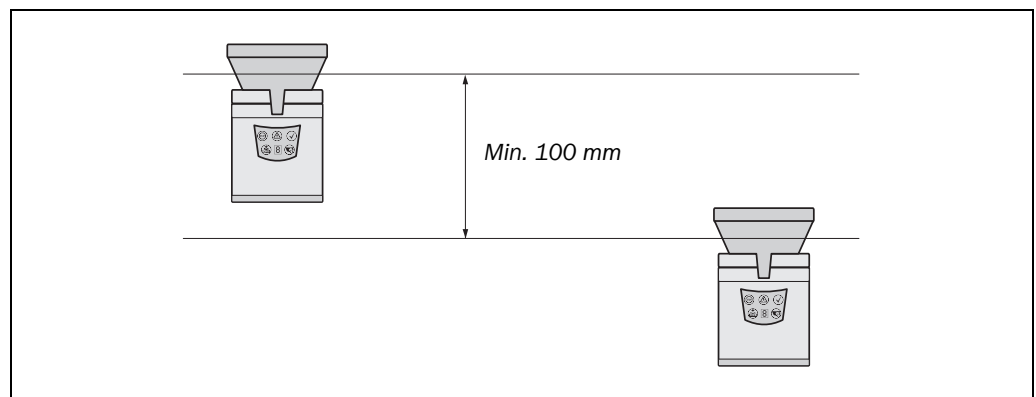

Fig. 30: Mounting on a cross

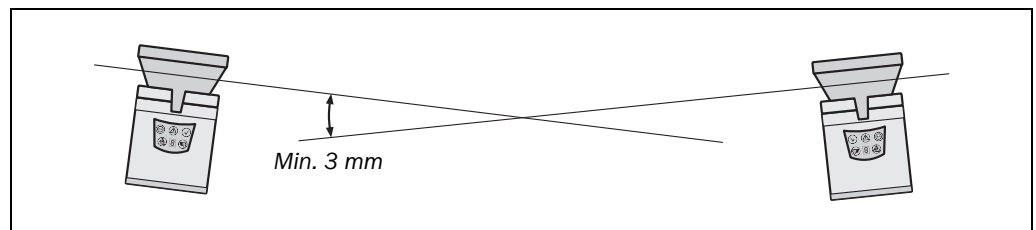
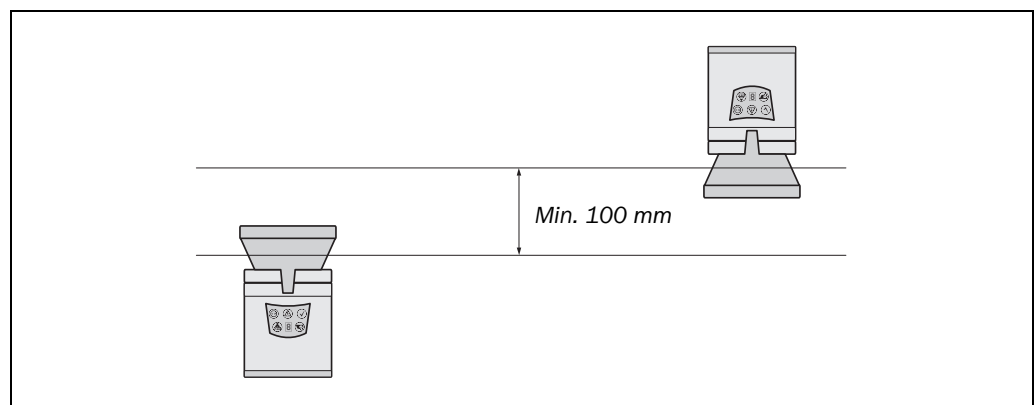

Fig. 31: Reverse mounting, parallel offset



## S200

Fig. 32: Reverse mounting of two S200, with parallel offset

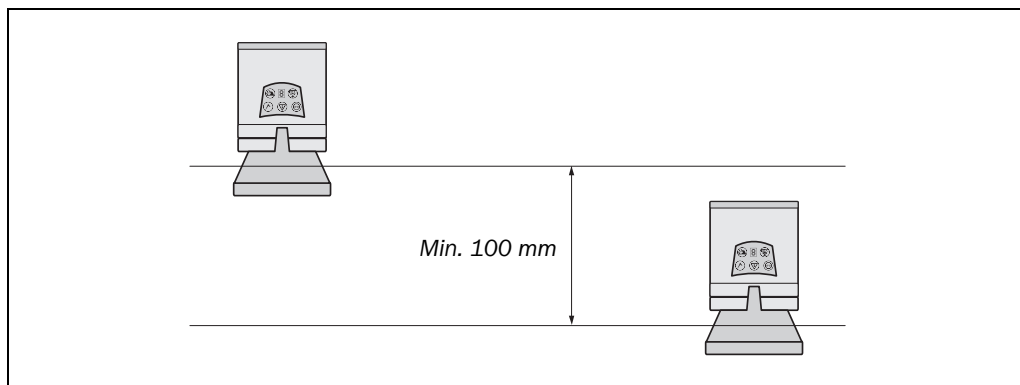
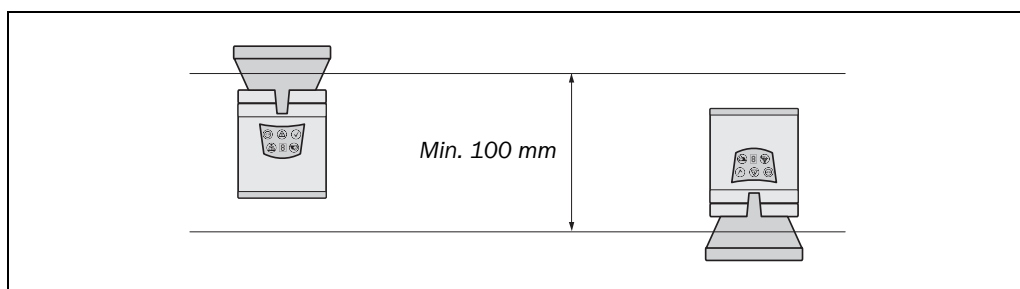

Fig. 33: Reverse mounting of one S200, with parallel offset



## 5 Electrical installation



WARNING

### Switch the entire machine/system off line!

The machine/system could inadvertently start up while you are connecting the devices.

- To prevent an unintentional start, ensure that the entire machine/system is disconnected during the electrical installation.

### Prevent the formation of a potential difference between the load and the protective device!

- If you connect loads that are not reverse-polarity protected to the OSSDs or the safety outputs, you must connect the 0 V connections of these loads and those of the corresponding protective device individually and directly to the same 0 V terminal strip. This is the only way to ensure that, in the event of a defect, there can be no potential difference between the 0 V connections of the loads and those of the corresponding protective device.

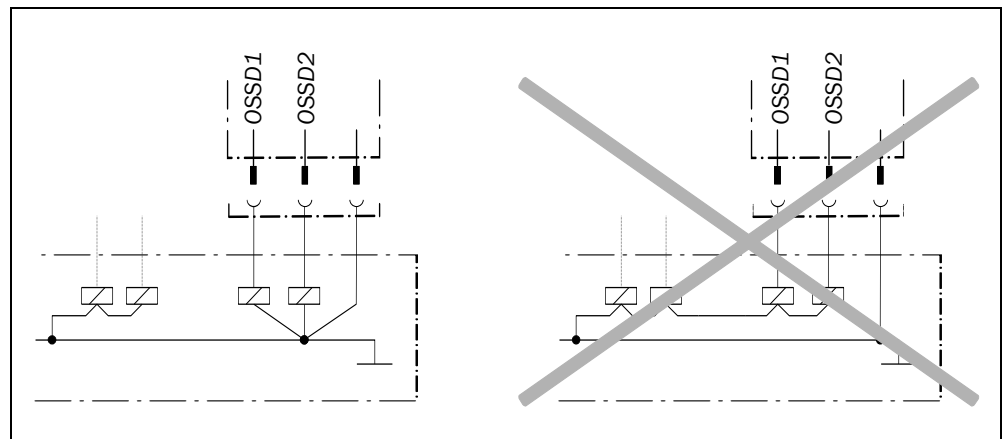

- Notes**
- Route all cables and connection cables such that they are protected from damage.
  - Ensure that any control systems or other devices forming part of the safety installation meet the stipulated category according to EN ISO 13849-1!
  - If you use screened cable, lay the screen evenly around the cable gland.
  - Ensure that the S200 is adequately protected electrically. You will find the electrical data necessary for determining the correct fuse in section 11.4 “Data sheet” on page 68.
- The electrical connections for the S200 are made at the system plug. A pre-assembled connector variant and an un-assembled connector variant are available (see page 49).

**5.1 System connection**

You will find all inputs and outputs of the S200 on the 24-pin screw terminal connection + FE in the system plug.

Fig. 34: Screw terminal strip on the system plug

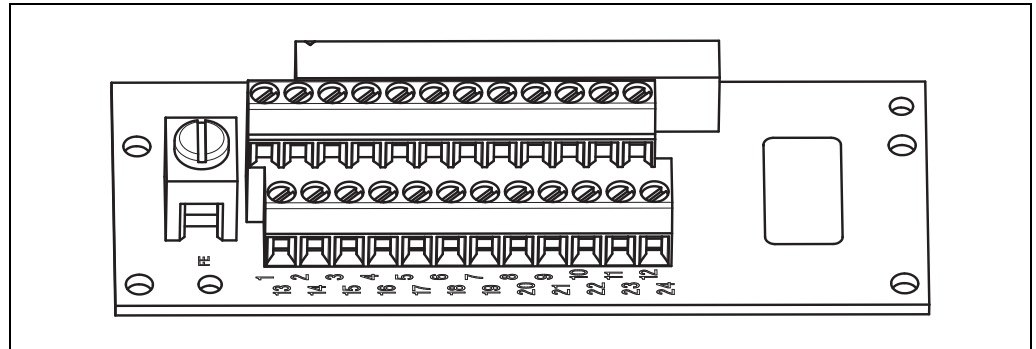

- Notes**
- If the cable gland/blanking plug is missing or not tightened, or if fixing screws are missing or not tightened on the system plug, the IP 65 enclosure rating is not met.
  - All inputs and outputs on the S200 are to be used only in the context specified.

**5.1.1 Pin assignment on the system plug**

Tab. 7: Terminal assignment at the system plug

Pin	Signal	Function
FE	Functional earth	
1	+24V DC	Supply voltage S200
2	0V DC	Supply voltage S200
3	OSSD1	Output signal switching device
4	OSSD2	Output signal switching device
5	RESET	Input, reset
6	EDM	Input, external device monitoring
13	ERR	Application diagnostic output – error/contamination
14	WF	Application diagnostic output, object in warning field
15	RES_REQ	Application diagnostic output, reset required
16	STBY	Control input for the activation of the stand-by mode

**5.1.2 OSSDs**



**WARNING**

**Only ever connect one downstream switching element to an OSSD!**

Each output signal switching device (OSSD) is only allowed to be connected to one switching element (e.g. relay or contactor). If several switching elements are required, you must choose a suitable form of contact duplication.

**5.1.3 Functional earth**

To achieve the specified EMC safety, the functional earth FE must be connected (e.g. to the central earth star point on the vehicle or the system).

## 5.2 System plug assembly

The system plug has holes for cable glands on the underside and on the rear.

system plug SX0B-A0000G

- 1 cable gland with M16 cable gland
- 1 cable gland without M16 cable gland (blanking plug)
- 2 cable glands without M12 cable gland (blanking plugs)

**Note** You can also procure the S200 with pre-assembled system plug with varying cable lengths (see section 5.3 “Pre-assembled system plugs” on page 49 and section 12.3.2 “System plug” on page 77).

Fig. 35: System plug SX0B-A0000G

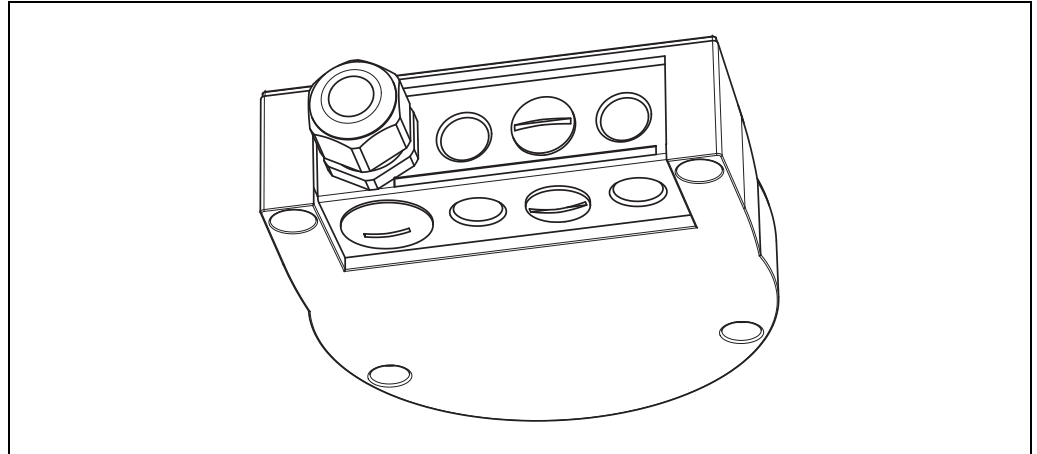

**Recommendation** If you do not want to assemble the system plug yourself, you will find suitable cables in the ordering information (see section 12.3.4 “Self assembly connecting cables” on page 78).



### 5.3 Pre-assembled system plugs

To connect the S200, the following pre-assembled system plugs are available (see also section 12.3.2 “System plug” on page 77):

- SX0B-B1105G
  - with 11 cores, unscreened (M16 cable gland)
  - 5 m long
- SX0B-B1110G
  - with 11 cores, unscreened (M16 cable gland)
  - 10 m long
- SX0B-B1120G
  - with 11 cores, unscreened (M16 cable gland)
  - 20 m long

Tab. 8: Pin assignment: pre-assembled system plug

Pin	Signal	Wire colour	SX0B-B1105G SX0B-B1110G SX0B-B1120G
FE	Functional earth	Green	■
1	+24V DC	Brown	■
2	0V DC	Blue	■
3	OSSD1	Grey	■
4	OSSD2	Pink	■
5	RESET	Red	■
6	EDM	Yellow	■
13	ERR	White/black	■
14	WF	White/brown	■
15	RES_REQ	Red/blue	■
16	STBY	White/green	■

## 6 Application examples and connection diagrams

The examples shown are only provided as an aid for your planning. You may need to consider additional protection measures for your application.

### 6.1 Stationary applications

#### 6.1.1 Applications with one monitored area

Fig. 36: Hazardous area protection

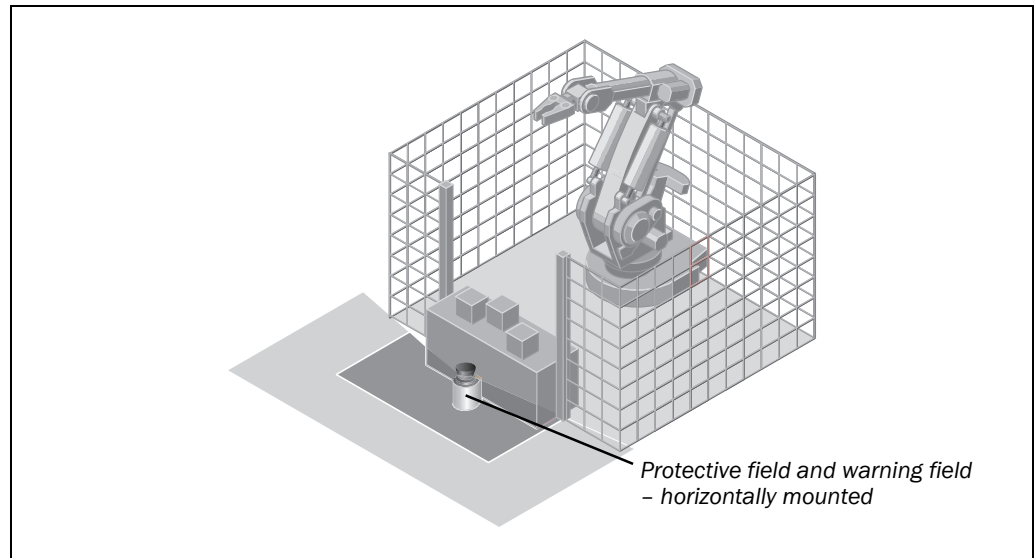

The area is permanently monitored by the S200.

Fig. 37: Access protection

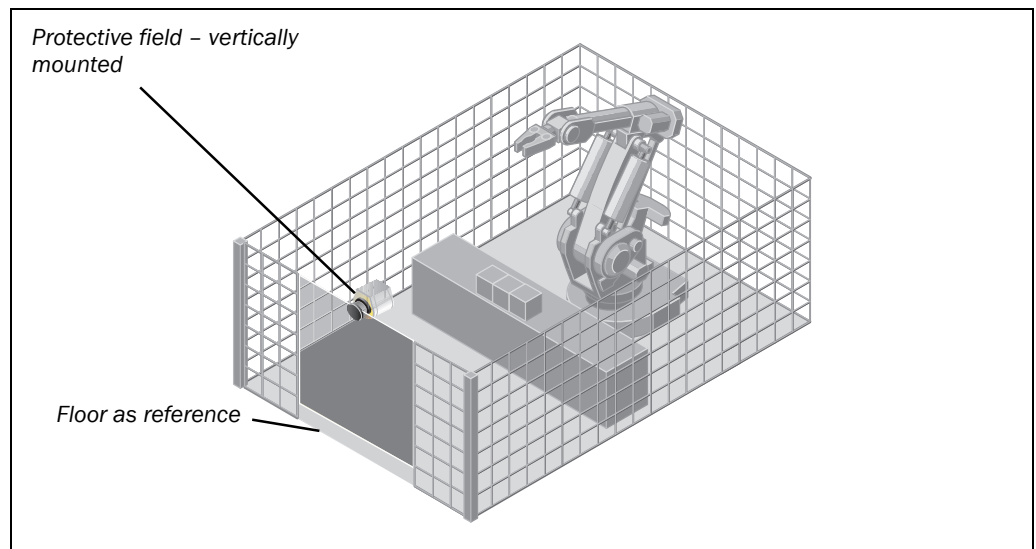

The access is monitored permanently. For safety against manipulation on the S200, e.g. the floor is used as a reference. If the alignment of the S200 changes (e.g. due to changes to the bracket), the S200 switches its OSSDs to the OFF state.

## 6.2 Connection diagrams

- Notes**
- Only use relays/contacts with positively guided contacts. The protection elements connected in parallel with the relays/contactors are used for arc-suppression.
  - Ensure that there is adequate arc-suppression at the relays/contactors. Take into account that arc-suppressors may lengthen the response time.
  - The arc-suppressors must be in parallel with the relays/contactors (not across the contacts).

**Sketch key**

- 1) = output circuits  
These contacts are to be connected to the controller such that, with the output circuit open, the dangerous state is disabled. Observe the maximum values for the loading of the outputs (see section 11.4 “Data sheet” on page 68).
- 2) = functional earth (FE)  
To achieve the specified EMC safety, the functional earth (FE) must be connected (e.g. to the central earth star point on the vehicle or the system).
- H2 = sensor for error/contamination
- H3 = sensor for Reset required
- H8 = sensor for warning field interruption

### 6.2.1 Restart interlock and external device monitoring

Fig. 38: Connection diagrams for restart interlock and external device monitoring

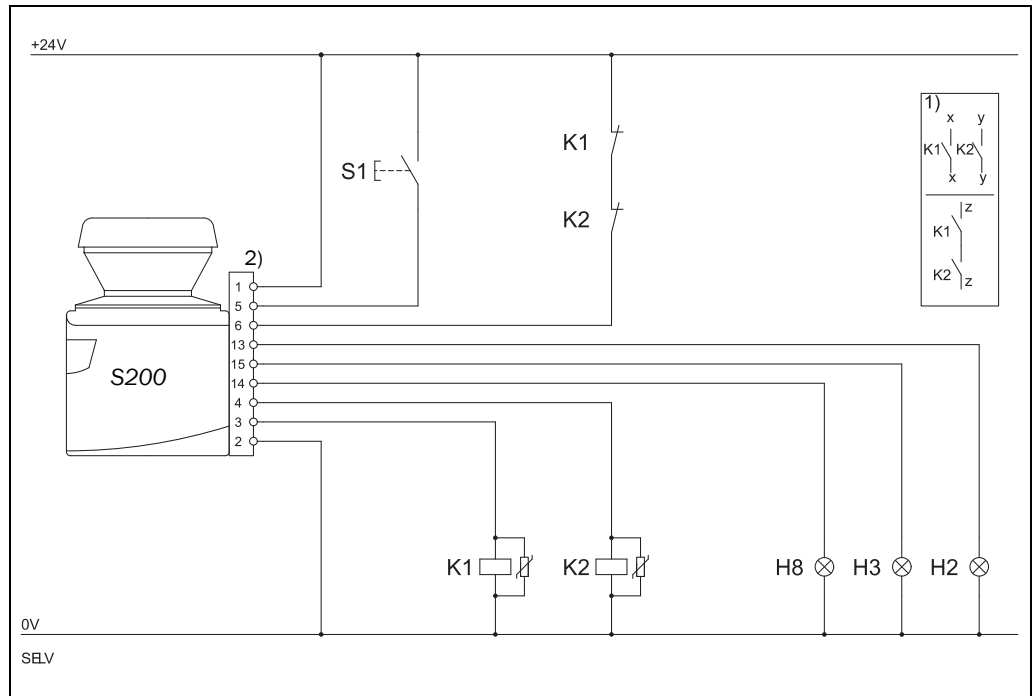



S200 in conjunction with relays/contactors; operating mode: with restart interlock and external device monitoring.

# 7 Configuration

## 7.1 Default delivery status

The S200 is delivered in a non-configured default status.

- The operational status is **Waiting for configuration**.
- The output signal switching devices (OSSDs) are in the OFF state, the red LED illuminates: .
- The 7-segment display indicates .

## 7.2 Preparation of the configuration

### How to prepare the configuration:

- Make sure that the safety laser scanner has been correctly mounted and that the electrical connections are correct and in place.
- Have the necessary tools at hand.

To configure the safety laser scanner you need:

- CDS (Configuration & Diagnostic Software) on CD-ROM, version 3.3 or higher
- user manual for CDS on CD-ROM
- PC/notebook with Windows 98/NT 4/2000 Professional/ME/XP and a serial RS-232 interface (PC/Notebook not included)
- service cable between PC and S200 (not in the delivery)

### How to configure the S200 with the aid of the CDS:

For configuration and diagnostics using the CDS, connect the PC to the configuration connection.

Fig. 39: Configuration connection

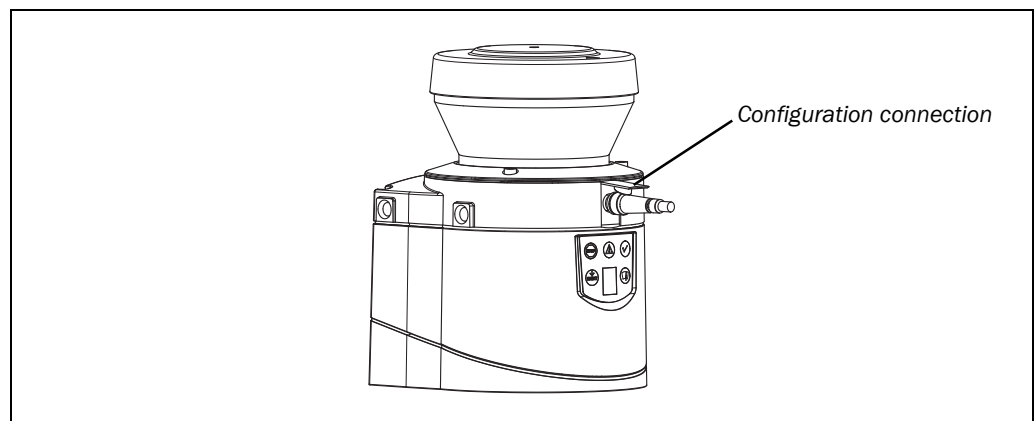

Two service cables of different length are available for the connection of the PC/notebook to the S200 (see 12.3 on page 77).

- Notes**
- Ensure that the service cable is not laid in close proximity to high power electrical drives or cables carrying high power. In this way you will avoid EMC effects on the service cable.
  - The service cable is only allowed to be connected for configuration and diagnostics. The service cable must be disconnected and the protective cap fitted in operation.

To configure the device, please read the user manual for the CDS (Configuration & Diagnostic Software) and use the online help function of the programme.

# 8 Commissioning

## 8.1 Initial commissioning



WARNING

### Commissioning requires a thorough check by qualified personnel!

Before you operate a system protected by the S200 safety laser scanner for the first time, make sure that the system is first checked and released by qualified personnel. The result of the test must be documented. Please read the notes in chapter 2 “On safety” on page 9.

- Prior to releasing the machine, check whether the access to the hazardous area or the hazardous point is completely monitored by the protective devices. Following approval of the machine also check at regular intervals (e.g. in the morning at the start of work) whether the S200 correctly switches the OSSDs to the OFF state as soon as there is an object in the protective field. This test should be performed along all protective field boundaries as per the specific regulations for the application (see section 8.3 “Test notes” on page 55).

### 8.1.1 Power up sequence

After power up the S200 runs through a power up cycle. During the power up cycle, the 7-segment display indicates the device status.

During the initial commissioning of an S200 the following indications are possible:

Tab. 9: 7-segment display during and after the power up sequence on initial commissioning

Step	Display	Meaning
1		Power-up cycle, testing the 7-segment display. All segments are activated sequentially.
2		Power up cycle, during initial commissioning: device in configuration mode
	Other display	Safety lock activated. Malfunction in external conditions or in the device itself. See section 10.4 “Error and status indications on the 7-segment display” on page 61.

Tab. 10: LED indication after the power up sequence

Step	Display					Meaning
1						Device self-test
2						Device self-test
3						Device status waiting for configuration or object in the protective field, OSSDs in the OFF state
	Other display					Safety lock activated. Malfunction (see section 10.3 "Error and status indications on the LEDs" on page 59)

**Note** The duration of power up depends on the volume of the configuration data and can take up to 25 seconds.

## 8.2 Re-commissioning

### Commissioning requires a thorough check by qualified personnel!

Before you re-commission a system protected by the S200 safety laser scanner for the first time, make sure that the system is first checked and released by qualified personnel. The result of the test must be documented. Please read the notes in chapter 2 "On safety" on page 9.

- Prior to releasing the machine, check whether the access to the hazardous area or the hazardous point is completely monitored by the protective devices. Following approval of the machine also check at regular intervals (e.g. in the morning at the start of work) whether the S200 correctly switches the OSSDs to the OFF state as soon as there is an object in the protective field. This test should be performed along all protective field boundaries as per the specific regulations for the application (see section 8.3 "Test notes" on page 55).

### 8.2.1 Power up sequence

After power up the S200 runs through a power up cycle. During the power up cycle, the 7-segment display indicates the device status.

During the re-commissioning of an S200 the following indications are possible:

Tab. 11: 7-segment display during and after the power up sequence on re-commissioning

Step	Display	Meaning
1		Power up cycle, testing the 7-segment display. All segments are activated sequentially.
2	No display or 	Device ready for operation or Device ready for operation but object in the protective field
	Other display	Safety lock activated. Malfunction (see section 10.3 "Error and status indications on the LEDs" on page 59).

**S200**

Tab. 12: LED indication after the power up sequence

Display					Meaning
					Power up cycle, step 1
					Power up cycle, step 2
					The device is operational, object in protective field and warning field.
					Or: The device is operational, object in warning field.
					Or: The device is operational, no object in protective field and warning field.
					Or: The device is operational, no object in protective field and warning field. Reset required
Other display					Safety lock activated. Malfunction (see section 10.3 "Error and status indications on the LEDs" on page 59)

## 8.3 Test notes

### 8.3.1 Pre-commissioning tests

The purpose of the pre-commissioning tests is to confirm the safety requirements specified in the national/international rules and regulations (EC Conformity). This applies particularly to the safety requirements in the machine directive or work equipment directive.



WARNING

**Ensure that you do not place anybody at risk during initial commissioning of the machine!**

Always expect that the machine, plant or the protective device does not yet behave as you have planned.

- Ensure that there are no persons in the hazardous area during initial commissioning.
- Check the effectiveness of the protective device mounted to the machine, using all selectable operating modes as specified in the checklist in the annex (see section 13.2 "Manufacturer's checklist" on page 80).
- Make sure that the operating personnel of the machine protected by the safety laser scanner are properly instructed by specialist personnel before being allowed to operate the machine. Instructing the operating personnel is the responsibility of the machine owner.
- Ensure that the information label **Important information**, which is included with the laser scanner on delivery, is affixed to the machine in a place where it is clearly visible for the operators. Ensure that the operators have the possibility to perform this daily check correctly.
- The annex to this document includes a checklist for review by the manufacturer and OEM. Use this checklist as a reference before commissioning the system for the first time (see section 13.2 "Manufacturer's checklist" on page 80).
- Document the adjustment of the scanner and the results of the testing during initial commissioning in a traceable manner. For this purpose also print out the complete configuration of the scanner (including protective field shapes) and include these with the documentation.

**Note** Your SICK subsidiary will be pleased to provide you with advice on initial commissioning.

### 8.3.2 Regular inspection of the protective device by qualified personnel

- Check the system following the inspection intervals specified in the national rules and regulations. This procedure ensures that any changes on the machine or manipulations of the protective device after the first commissioning are detected.
- If major changes have been made to the machine or the protective device, or if the safety laser scanner has been modified or repaired, check the plant again as per the checklist in the annex (see section 13.2 “Manufacturer’s checklist” on page 80).

### 8.3.3 Daily testing of the protective device by a specialist or authorised personnel

The effectiveness of the protective device must be checked daily by a specialist or by authorised personnel. The test must also be performed if the operating mode is changed.



WARNING

#### No further operation if errors occur during the test!

If any one of the following points is not met, it is not permitted to continue to work on the machine or operate the vehicle. In this case the installation of the S200 must be checked by specialised personnel (see section 8.3.2 “Regular inspection of the protective device by qualified personnel” on page 56).

- Check the mechanical installation to ensure that all mounting screws are secure and that the is properly aligned S200.
- Check each S200 device for visible changes such as damage, manipulation etc.
- Switch on the machine/plant.
- Watch the LEDs on each S200.
- If not at least one LED of each S200 is permanently lit when the machine/plant is switched on, it is to be assumed that there is a fault in the machine or plant. In this case the machine must be shut down immediately and checked by a specialist.
- Deliberately obstruct the protective field without risk to any personnel while the machine is running in order to test the effectiveness of the entire system. The LEDs of the S200 device must change from green to red and the dangerous movement must stop immediately.

Repeat this test at different points in the danger area and on all S200 devices . If you discover any non-conformance of this function, the machine/plant must be shut down immediately and checked by a specialist.

- For stationary applications, check that the danger area marked out on the floor matches the shape of the protective field stored in the S200 and that any gaps are protected by additional safety measures. In the case of mobile applications, check that the moving vehicle actually stops in a timely manner at the protective field boundaries which are set in the S200 and listed on the information label on the vehicle or in the configuration protocol. If you discover any non-conformance of this function, the machine/plant/vehicle must be stopped immediately and checked by a specialist.



## 9 Care and maintenance



WARNING

### Do not make any repairs to the device!

The S200 does not contain any repairable components. For this reason do not open the S200 components and only replace the parts that are described in the following chapters as replaceable.

### Switch the entire machine/system off line!

The system could inadvertently start up while you are replacing the optics cover. As a matter of principle, always isolate the machine from the power supply during all work on the machine and safety laser scanner.

## 9.1 Cleaning optics cover

The S200 safety laser scanner is largely maintenance-free. The optics cover on the safety laser scanner should however be cleaned regularly and if it is contaminated.

- Do not use aggressive detergents.
- Do not use abrasive cleaning agents.

**Note** Static charges cause dust particles to be attracted to the optics cover. You can diminish this effect by using the anti-static plastic cleaner (SICK Part No. 5600006) and the SICK lens cloth (Part No 4003353) (see section 12.3 “Accessories/spare parts” on page 77).

### How to clean the optics cover:

- Use a clean and soft brush to remove dust from the optics cover.
- Now wipe the window for light output on the optics cover with a clean and damp cloth.

## 9.2 Replacing optics cover



WARNING

### Perform an optics cover calibration with the aid of the CDS after the replacement of the optics cover!

The level of contamination is measured continuously during the operation of the S200. For this purpose the optics cover calibration must first be performed; this then serves as a reference for the contamination measurement (status = not contaminated).

The optics cover calibration is only allowed to be performed with a new optics cover! The new optics cover must be free of contamination at the time of the optics cover calibration. The optics cover calibration should be performed at room temperature (10-30 °C)!

If the optics cover is scratched or damaged, you must replace the optics cover. Order the replacement optics cover from SICK (see section 12.3 “Accessories/spare parts” on page 77).

- Notes**
- The optics cover on the S200 is an optical part that must not be soiled or scratched on replacement.
  - The optics cover is only allowed to be replaced by specialist personnel in a dust and dirt-free environment.
  - Never replace the optics cover during ongoing operation, as internal parts may be irreparably damaged in certain circumstances and dust particles may enter the device.
  - It is imperative that you avoid contamination of the inside, e.g. with fingerprints.

- Do not use any additional sealant for sealing the optics cover, e.g. silicon, as these substances may affect the optics.
- Mount the optics cover as per the following instructions to ensure that the housing is sealed to IP 65.

**This is how you replace the optics cover:**

**Notes**

- Only use a **new** optics cover (see 12.3.8 on page 78).
- When replacing the optics cover, take ESD protection measures.
- Set a torque wrench to 1.2 Nm (hand-tight) and have this at hand.
- Disconnect the system plug and remove the S200.
- Take the S200 to a clean place (office, repair shop or similar).
- First clean the outside of the S200. This prevents foreign bodies entering the device when it is opened.
- Undo the fixing screws ① to ③ for the optics cover.

Fig. 40: Undo the fixing screws for the front screen

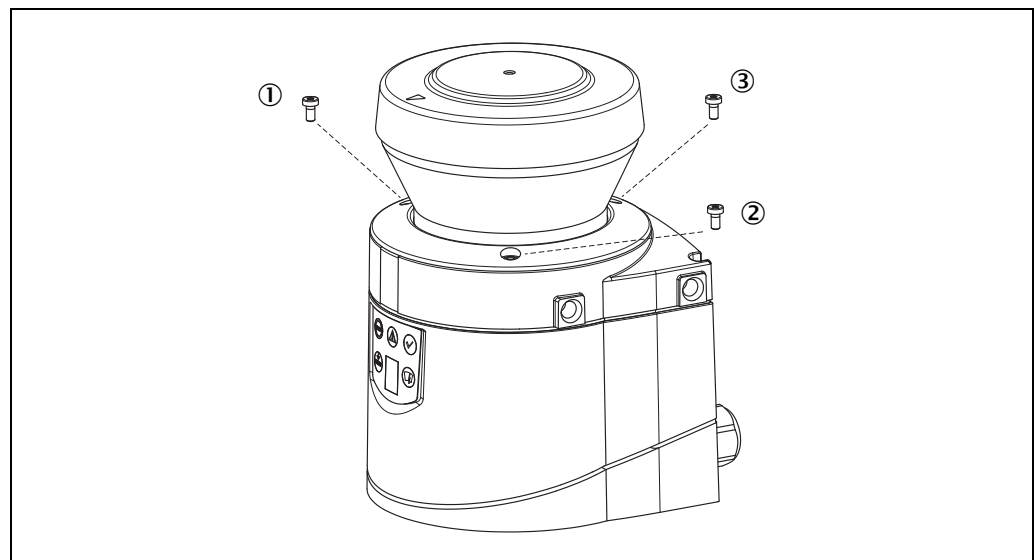

- Then remove the optics cover.
- Check whether the mirror on the motor is clean and remove any contamination with an optic brush.
- Take the new optics cover out of the packaging and remove the protection for the seal.
- Remove any remnants of packaging.
- Place the optics cover on the laser scanner and fit the new fixing screws ① to ③.
- When fitting the new cover, ensure the arrow on the top of the cover points to the front and that the optics cover **is fully in contact without a gap**.
- Then tighten the front screws with the torque set.
- Make sure the optics cover is free of dirt and that it is not damaged.

**Re-commissioning the S200:**

- Correctly re-mount the S200 (see chapter 4 “Mounting” on page 30).
- Connect the S200 system plug.
- Then perform an optics cover calibration with the aid of the CDS.



# 10 Diagnostics

This chapter describes how to identify and remedy errors and malfunctions during the operation of the safety laser scanner.

## 10.1 In the event of faults or errors



WARNING

### Do not operate if behaviour is unclear!

Stop the machine, the system or the vehicle if you cannot clearly identify or allocate an error and if you cannot safely remedy the malfunction.

## 10.2 SICK support

If you cannot remedy an error with the help of the information provided in this chapter, please contact your local SICK representative.

Make a note of the telephone number of your SICK subsidiary so that you or other users have this number easily at hand. You will find the telephone number on the rear of these operating instructions.

Telephone number of your SICK subsidiary











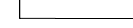

## 10.3 Error and status indications on the LEDs

This section describes the meaning of the indications and LED error messages and how you can respond. You will find a description of the indicators in section 3.6 “Indicators and outputs” on page 28, the connections for the outputs in section 5.1 “System connection” on page 47.

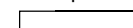
Tab. 13: Status indicators during operation







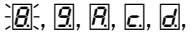

Display	Output level	Possible cause
	At the OSSDs 	Object in the protective field, OSSDs in the OFF state
	At the OSSDs 	Protective field unoccupied, OSSDs in ON state
	At the warning field output 	Object in warning field

Tab. 14: LED error messages

Display	Output level	Possible cause	Remedying the error
	At the OSSDs  On the application diagnostic output 	No operating voltage, or voltage too low	➤ Check the voltage supply and activate, if necessary.
	At the Res_Req output  1 Hz	Reset required	➤ Operate the control switch for restarting or resetting.
	On the error/contamination output 	No error	
	On the application diagnostic output 	Optics cover contaminated, no operation	➤ Clean the optics cover.
	On the application diagnostic output  1 Hz	Optics cover contaminated, still in operation	➤ Clean the optics cover.
	On the application diagnostic output  4 Hz	System error	➤ Pay attention to the error display of the 7-segment display or carry out a diagnostics with the aid of the CDS. ➤ If necessary, switch the device off and back on again.

## 10.4 Error and status indications on the 7-segment display

### The lock-out operational status

In case of certain faults or an erroneous configuration, the system can go into the lock-out status. The 7-segment display on the safety laser scanner then indicates , , , , , ,  or . To place the device back in operation, proceed as follows:













- Rectify the cause of the fault as per Tab. 15.
- Switch the power supply for the S200 off and back on again.











**Or**









Restart the laser scanner with the aid of the CDS.

This section explains the meaning of the error displays on the 7-segment display and how to respond to the messages. You will find a description of the positions and symbols on the S200 in section 3.6 “Indicators and outputs” on page 28.

Tab. 15: Error and status indications on the 7-segment display

Display	Possible cause	Remedying the error
	Power-up cycle – all segments are activated sequentially.	No error
	Object in protective field	No error
	Initialising the device	<ul style="list-style-type: none"> <li>➤ The display goes out automatically when the S200 has been initialised.</li> <li>If the display  does not go off:                             <ul style="list-style-type: none"> <li>➤ Check the system configuration with the aid of the CDS. Transfer the corrected configuration to the S200 again.</li> </ul> </li> </ul>
	Waiting for configuration or configuration not completed	<ul style="list-style-type: none"> <li>➤ Prepare a configuration with the aid of the CDS (Configuration &amp; Diagnostic Software) or transfer an existing configuration to the S200.</li> </ul>
 or 	EDM error	<ul style="list-style-type: none"> <li>➤ Check whether the contactors are working correctly or if they are wired incorrectly and rectify any error.</li> <li>➤ If  is displayed: Switch the device off and back on again.</li> </ul>
	Error in control switch for restarting or resetting	<ul style="list-style-type: none"> <li>➤ Check the functionality of the control switch. The button may be defective or operated.</li> <li>➤ Check the wiring of the control switch for short-circuit to 24 V.</li> </ul>
	S200 faulty	➤ Send the S200 to the manufacturer for repair.
	Overcurrent on OSSD connection 1	<ul style="list-style-type: none"> <li>➤ Check the switching element connected (contactor, relay). Replace, if necessary.</li> <li>➤ Check the wiring for short-circuit to 0 V.</li> </ul>
	Short-circuit to 24 V at OSSD connection 1	➤ Check the wiring for short-circuit to 24 V.

Display	Possible cause	Remedying the error
	Short-circuit to 0 V at OSSD connection 1	➤ Check the wiring for short-circuit to 0 V.
	Overcurrent on OSSD connection 2	➤ Check the switching element connected (contactor, relay). Replace, if necessary. ➤ Check the wiring for short-circuit to 0 V.
	Short-circuit to 24 V at OSSD connection 2	➤ Check the wiring for short-circuit to 24 V.
	Short-circuit to 0 V at OSSD connection 2	➤ Check the wiring for short-circuit to 0 V.
	Short-circuit between OSSD connection 1 and 2	➤ Check the wiring and rectify the error.
	General OSSD wiring error	➤ Check the complete wiring of the OSSDs.
	Maximum measuring range exceeded	➤ For the correct function of the safety laser scanner, always ensure that measured values are received within a sector of 90°. In this sector the laser scanner must detect, e.g., building walls within its maximum measuring range of 30 m.
	Device is dazzled	➤ Check whether the S200 is being dazzled by an external light source, e.g. headlight, infrared light sources, stroboscopic light, sun etc. If necessary, re-mount the device.
	Temperature error. The operating temperature of the S200 has exceeded the permissible range.	➤ Check whether the S200 is operated as per the permissible ambient conditions.
	Invalid configuration of the EDM	➤ Verify that the EDM on the machine controller is connected.
	There is a short-circuit between the input for the control switch for restarting or resetting and another input or output.	➤ Check the cabling for cross-circuits.

Display	Possible cause	Remedying the error
	Stand-by mode, the OSSDs are in the OFF state, the laser is switched off.	No error. If the criteria for the stand-by mode are withdrawn, readiness for operation is re-established. If the display  does not go off: ➤ Check the level on the STBY input.
  	Window for light output on the optics cover contaminated	➤ Clean the window for the light output on the optics cover.
  	Dazzling of the contamination measurement (there may not be an optics cover fitted)	➤ Check whether the S200 is being dazzled by an external light source, e.g. headlight, infrared light source, stroboscopic light, sun etc. or ➤ Fit the new optics cover (then perform optics cover calibration).

**Note** If you have problems during troubleshooting, contact SICK support. Keep a copy of the print out of the results of the diagnostics at hand.

## 10.5 Extended diagnostics

The CDS software supplied with the device (Configuration & Diagnostic Software) includes extended diagnostic options. It allows you to narrow down the problem if the error is non-specific or if you experience usage downtime problems. Detailed information to be found ...

- in the online help for the CDS (Configuration & Diagnostic Software).
- in the user manual for the CDS.

# 11 Technical specifications

## 11.1 Characteristics

Fig. 41: Diagram of scanning ranges for various reflectances

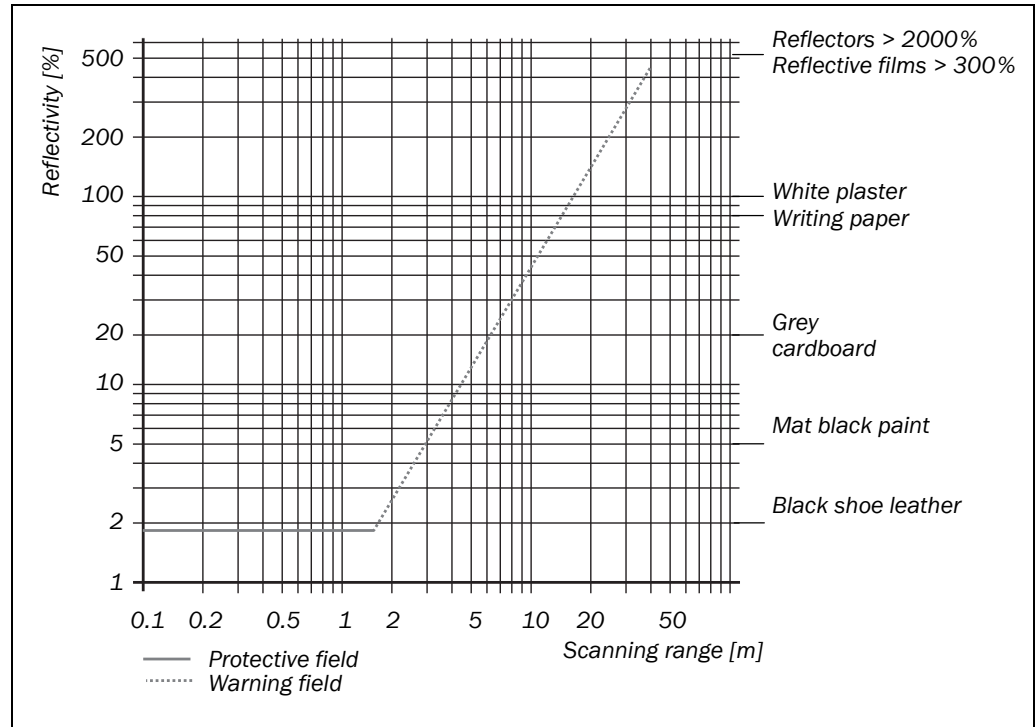

## 11.2 OSSD response times

The total response time of your application is dependent on ...

- the basic response time of the S200.
- the multiple sampling set.
- the OSSDs used.

How to calculate the total response time  $T_S$ :

$$T_S = t_B + T_{MFA}$$

Where ...

$$t_B = \text{Basic response time} = 80 \text{ ms}$$

$$T_{MFA} = \text{Supplement due to multiple sampling} > 2$$



**S200****Multiple sampling**

On the S200 at least double multiple sampling is always set. For a multiple sampling of 3 or higher you must add a supplement of 80 ms to the basic response time.

Tab. 16: Supplements for multiple sampling

<b>Multiple sampling</b>	<b>Supplement</b>	<b>Basic response time + supplement</b>
2 times (basic setting)	0 ms	80 ms
3 times	40 ms	120 ms
4 times	80 ms	160 ms
5 times	120 ms	200 ms
6 times	160 ms	240 ms
7 times	200 ms	280 ms
8 times	240 ms	320 ms
9 times	280 ms	360 ms
10 times	320 ms	400 ms
11 times	360 ms	440 ms
12 times	400 ms	480 ms
13 times	440 ms	520 ms
14 times	480 ms	560 ms
15 times	520 ms	600 ms
16 times	560 ms	640 ms

### 11.3 Timing behaviour of the OSSDs

The S200 tests the OSSDs immediately after switch on and then at regular intervals. For this purpose the S200 briefly switches off both OSSDs (for 300  $\mu$ s) and checks whether the OSSDs switch to the OFF state during this time.

**Note** Ensure that the safety inputs on the controller used do not respond to these test pulses and as a result cause the machine or system to unintentionally shutdown!

Fig. 42: Diagram of the test pulses at the OSSDs

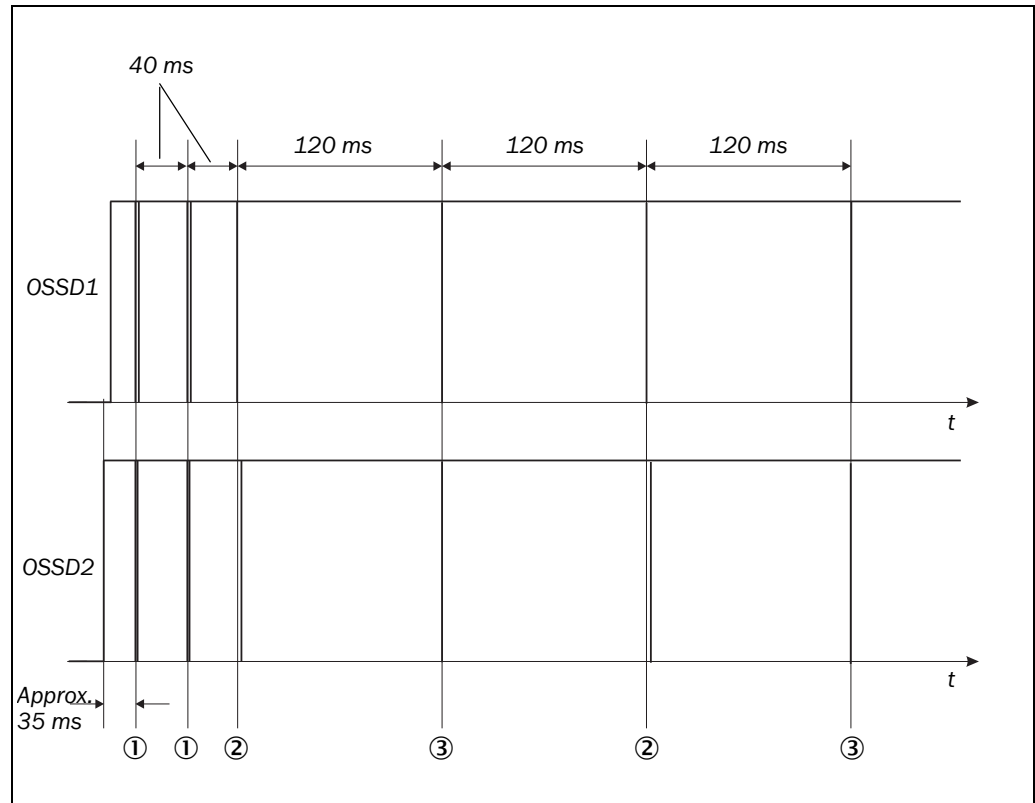

Approx. 35 ms after the switch on of the OSSDs, the S200 performs the first voltage test ① and then after a half basic response time (40 ms) performs a second voltage test ①.

After a further half basic response time of the S200 there is a shut-down test ②, 120 ms later a further voltage test ③. Then the S200 performs a shut-down test and a voltage test alternately at an interval of 120 ms. Fig. 43, Fig. 44 and Fig. 45 show the pulse durations for the individual tests.

**S200**

Fig. 43: Voltage test after switching on the OSSDs

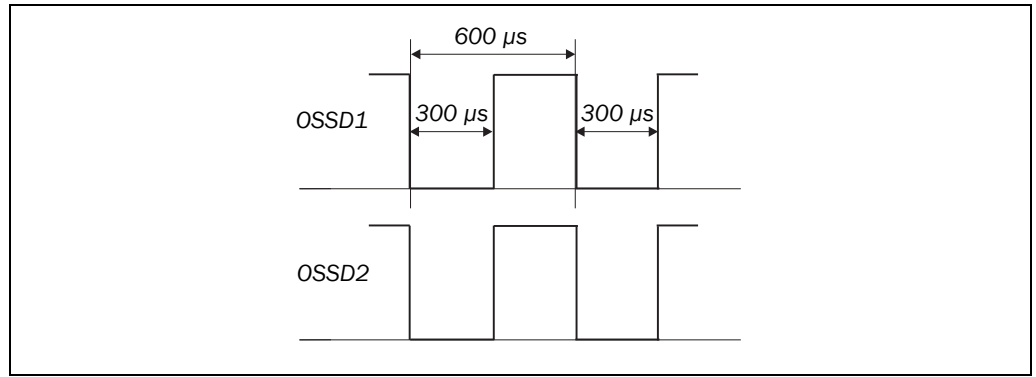

Fig. 44: Shut-down test

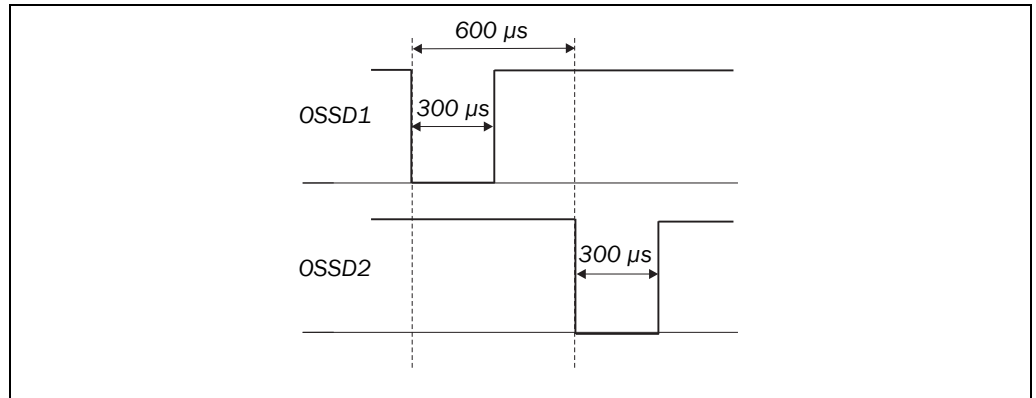
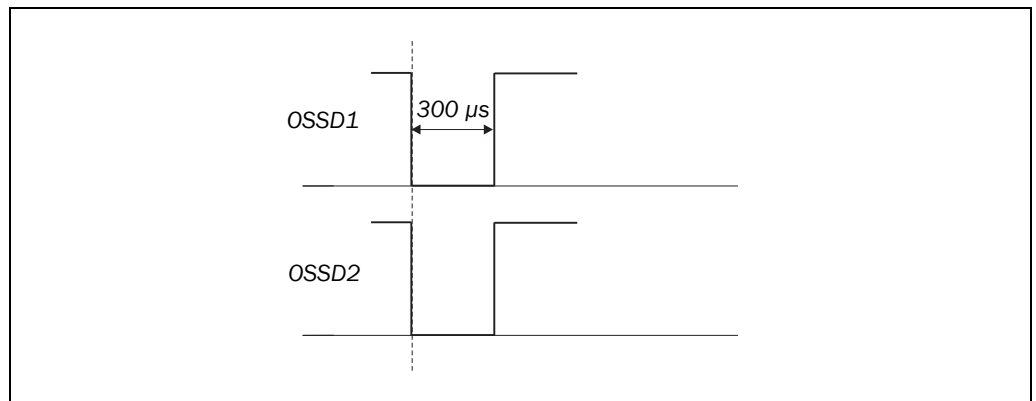

Fig. 45: Voltage test



## 11.4 Data sheet

Tab. 17: Data sheet S200

	Minimum	Typical	Maximum
<b>General data</b>			
Type	Type 2 (EN 61496-1)		
Safety Integrity Level <sup>2)</sup>	SIL1 (IEC 61508)		
SIL claim limit <sup>2)</sup>	SILCL1 (EN 62061)		
Category	Category 2 (EN ISO 13849-1)		
Performance Level <sup>2)</sup>	PL c (EN ISO 13849)		
PFHd (mean probability of a dangerous failure per hour)	52,9 × 10 <sup>-9</sup>		
T <sub>M</sub> (mission time)	20 years (EN ISO 13849)		
Laser protection class	Laser class 1 (IEC 60825-1. Complies with 21 CFR 1040.10 and 1040.11)		
Enclosure rating	IP 65 (EN 60529)		
Protection class	II (EN 50178)		
Operating temperature range	-10 °C		+50 °C
Storage temperature range	-25 °C		+70 °C (≤24 h)
Humidity (taking into account the operating temperature range)	EN 61496-1, section 5.1.2 and 5.4.2, as well as CLC/TS 61496-3, section 5.4.2		
Vibration	EN 61496-1, section 5.1.2 and 5.4.4.1, as well as CLC/TS 61496-3, section 5.4.4.1		
Frequency range	10 Hz		150 Hz
Amplitude	0.35 mm or 5 g		
Shock resistance	EN 61496-1, section 5.1 and 5.4.4.2, as well as CLC/TS 61496-3, section 5.4.4.2		
Single shock	15 g, 11 ms		
Continuous shock	10 g, 16 ms		
Sender	Pulsed laser diode		
Wavelength	895 nm	905 nm	915 nm
Divergence of the collimated beam (solid angle)		14 mrad	
Pulse duration			4.5 ns
Average output power			1.76 μW
Light spot size at optics cover		8 mm	
Size of light spot at 1.5 m scanning range		28 mm	

<sup>2)</sup> For detailed information on the exact design of your machine/system, please contact your local SICK representative.

	Minimum	Typical	Maximum
Housing			
Material	Aluminium die-cast		
Colour	RAL 1021 (rape yellow)		
Optics cover			
Material	Polycarbonate		
Surface finish	Outside with scratch-resistant coating		
System plug	ESD protected		
Material	Aluminium die-cast		
Colour	RAL 9005 (black)		
Dimensions S200 <sup>3)</sup>			
Height			152 mm
Width			102 mm
Depth			105 mm
Total weight (without connecting cables)		1.2 kg	
Basic response time	80 ms		

**Functional data**

Resolution	30, 40, 50, 70 mm		
Protective field of the S200			
At 30 mm resolution			1.25 m
At 40, 50, 70 mm resolution			1.50 m
Scan angle			270°
Reflectivity	1.8 %		Several 1000 % (reflectors <sup>4)</sup> )
Angular resolution		0.5°	
Protective field supplement generally necessary			100 mm
Supplement for retroreflectors in scan plane at a distance of less than 1 m to the protective field boundary			200 mm
Evenness of the scan field at 1.5 m			±50 mm
Distance from mirror axis of rotation (zero point on the X- and Y axis) to the rear of the device		55 mm	
Distance between centre of the scan plane and the bottom edge of the housing		116 mm	
Warning field <sup>5)</sup>		8 m	
Distance measuring range			30 m

<sup>3)</sup> Without fixing screws and projection of cable glands with system plug mounted.

<sup>4)</sup> Complies with Diamond Grade 3000X™ (approx. 1250 cd/lx × m²).

<sup>5)</sup> The detection capability of the warning field is dependent on the remission of the objects to be detected (see section 11.1 on page 64).

	Minimum	Typical	Maximum
Number of multiple samplings (configurable via CDS)	2		16
Power-up delay Of a configured device		15 s	25 s
Restart after (configurable)	2 s		60 s

**Electrical data**

Supply voltage (SELV) <sup>6)</sup>	16.8 V	24 V	30 V
Permissible residual ripple <sup>7)</sup>			±5 %
Switch on current <sup>8)</sup>			2 A
Operating current at 24 V without output load		0.25 A	0.33 A
Operating current with max. output load			1.65 A
Power consumption without output load		6 W	8 W
Power consumption with maximum output load			40 W
Electrical connection	System plug with screw terminal connections		
Technical specifications, screw type terminal FE			
Cross-section of rigid cores	0.3 mm <sup>2</sup>		1.6 mm <sup>2</sup>
Cross-section of flexible cores <sup>9)</sup>	0.3 mm <sup>2</sup>		1.6 mm <sup>2</sup>
American Wire Gauge (AWG)	22		14
Insulation stripping length for the cores		5 mm	
Screw tightening torque			0.5 Nm
Technical specifications, screw terminals			
Cross-section of rigid cores	0.14 mm <sup>2</sup>		1.5 mm <sup>2</sup>
Cross-section of flexible cores <sup>10)</sup>	0.14 mm <sup>2</sup>		1.0 mm <sup>2</sup>
American Wire Gauge (AWG)	26		16
Insulation stripping length for the cores		5 mm	
Screw tightening torque	0.22 Nm		0.3 Nm
Cable length for power supply tolerance ±10 %			
For wire cross-section 1 mm <sup>2</sup>			50 m
For wire cross-section 0.5 mm <sup>2</sup>			25 m
For wire cross-section 0.25 mm <sup>2</sup>			12 m

<sup>6)</sup> The voltage supply must be capable of buffering brief mains voltage failures of 20 ms as specified in EN 60204. Suitable power supplies are available as accessories from SICK (Siemens series 6 EP 1 – as per DIN 40839-1, test pulse 5 (Load Dump) limited to 58 V, tested!)

<sup>7)</sup> The absolute voltage level must not drop below the specified minimum voltage.

<sup>8)</sup> The load currents for the input capacitors are not taken into account.

<sup>9)</sup> Core terminating sleeves are not required.

<sup>10)</sup> Core terminating sleeves are not required.

	Minimum	Typical	Maximum
Cable length for power supply tolerance $\pm 5\%$ For wire cross-section 1 mm <sup>2</sup> For wire cross-section 0.5 mm <sup>2</sup> For wire cross-section 0.25 mm <sup>2</sup>			60 m 30 m 15 m
Cable length for power supply tolerance $\pm 1\%$ For wire cross-section 1 mm <sup>2</sup> For wire cross-section 0.5 mm <sup>2</sup> For wire cross-section 0.25 mm <sup>2</sup>			70 m 35 m 17 m
Input for control switch for restarting or resetting Input resistance when HIGH Voltage for HIGH Voltage for LOW Input capacitance Static input current	11 V -3 V 6 mA	2 k $\Omega$ 24 V 0 V 15 nF	30 V 5 V 15 mA
Input EDM Input resistance when HIGH Voltage for HIGH Voltage for LOW Input capacitance Static input current	11 V -3 V 6 mA	2 k $\Omega$ 24 V 0 V 15 nF	30 V 5 V 15 mA
Stand-by mode input Input resistance when HIGH Voltage for HIGH Voltage for LOW Input capacitance Static input current	11 V -3 V 6 mA	2 k $\Omega$ 24 V 0 V 15 nF	30 V 5 V 15 mA

	Minimum	Typical	Maximum
OSSDs	2 PNP semiconductors, short-circuit protected <sup>11)</sup> , cross-circuit monitored		
Output signal switching device pair			
HIGH switching voltage at 250 mA	$U_V - 2.7 \text{ V}$		$U_V$
Switching voltage LOW	0 V	0 V	3.5 V
Source switching current <sup>12)</sup>	6 mA		0.25 A
Leakage current <sup>13)</sup>			250 $\mu\text{A}$
Load inductance			2.2 H
Load capacity			2.2 $\mu\text{F}$ at 50 $\Omega$
Switching sequence (without switching)			5 $\frac{1}{\text{s}}$
Permissible cable resistance <sup>14)</sup>			2.5 $\Omega$
Test pulse width <sup>15)</sup>		230 $\mu\text{s}$	300 $\mu\text{s}$
Test frequency		120 ms	
Switching time of the OSSDs from red to green		120 ms	
Time offset on switching the OSSDs between OSSD2 and OSSD1			2 ms
Application diagnostics outputs warning field, contamination of the optics cover/error, reset required			
HIGH switching voltage at 200 mA	$U_V - 3.3 \text{ V}$		$U_V$
Source switching current		100 mA	200 mA
Current limiting (after 5 ms at 25° C)	600 mA		920 mA
Power up delay		1.4 ms	2 ms
Switch off delay		0.7 ms	2 ms

<sup>11)</sup> Applies to the voltage range between  $V_s$  and 0 V.

<sup>12)</sup> Switching currents up to 500 mA are allowed briefly ( $\leq 100$  ms).

<sup>13)</sup> In the case of a fault (0-V cable open circuit) maximally the leakage current flows in the OSSD cable. The downstream controller must detect this status as LOW. A FPLC (fail-safe programmable logic controller) must be able to identify this status.

<sup>14)</sup> Make sure to limit the individual line core resistance to the downstream controller to this value to ensure that a cross-circuit between the outputs is safely detected. (Also note EN 60204-1.)

<sup>15)</sup> When active, the outputs are tested cyclically (brief LOW). When selecting the downstream controllers, make sure that the test pulses do not result in deactivation.



	Minimum	Typical	Maximum
<b>Configuration and diagnostics interface</b>			
Communication protocol	RS-232 (proprietary)		
Transmission speed	38400 Baud		
Cable length at 38400 Baud and 0.25-mm <sup>2</sup> cables			15 m
Galvanic de-coupling	No		
Output TxD HIGH	5 V		15 V
Output TxD LOW	-15 V		-5 V
Voltage range RxD	-15 V		15 V
Switching threshold RxD LOW	-15 V		0.4 V
Switching threshold RxD HIGH	2.4 V		15 V
Short-circuit current at TxD	-60 mA		60 mA
Max. voltage level at RxD	-15 V		15 V
Max. voltage level at TxD	-11 V		11 V

11.5 Dimensional drawings

11.5.1 S200

Fig. 46: S200 dimensional drawing (mm)

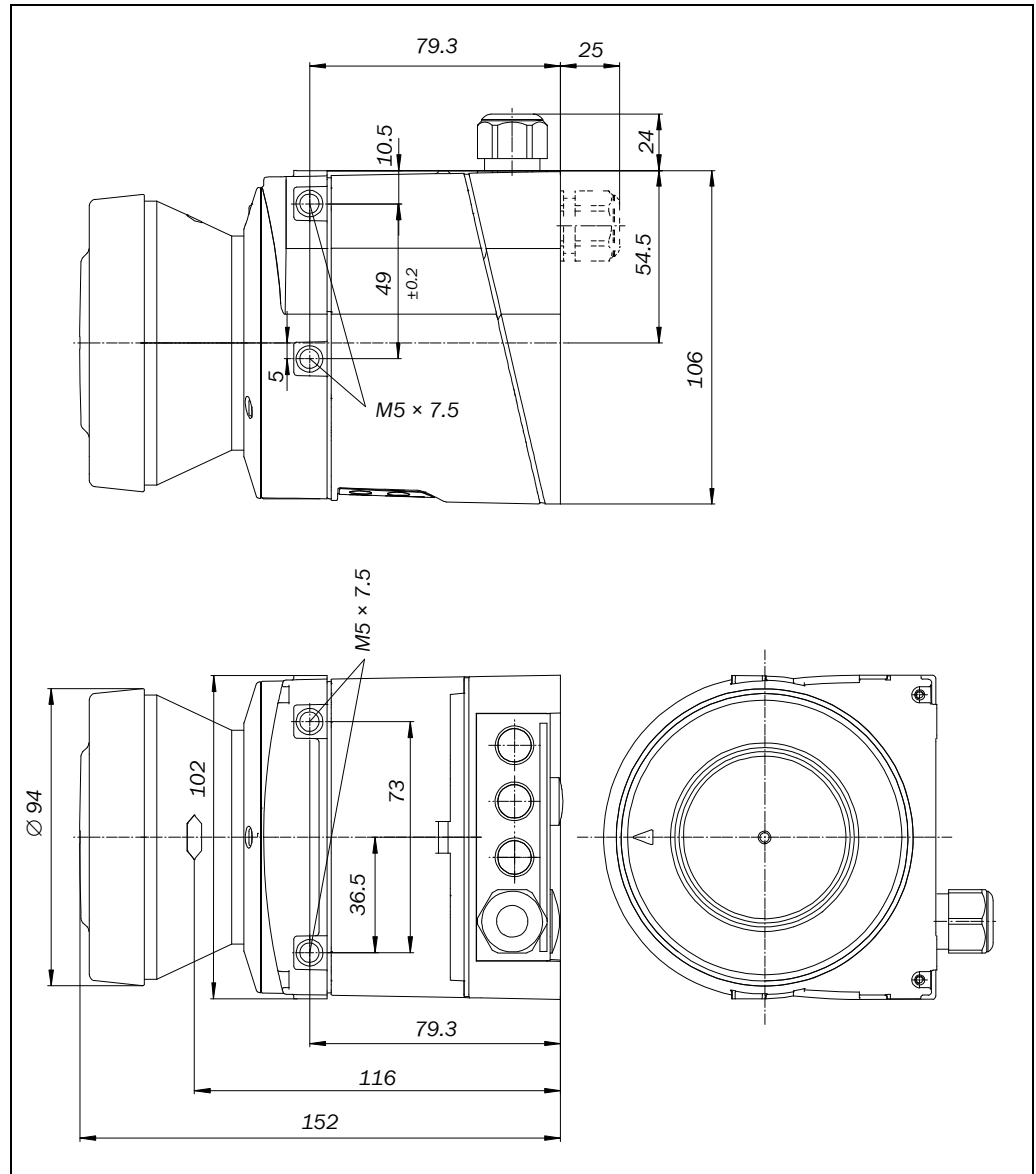

11.5.2 Mounting kits

Fig. 47: Dimensional drawing, mounting kit 1a

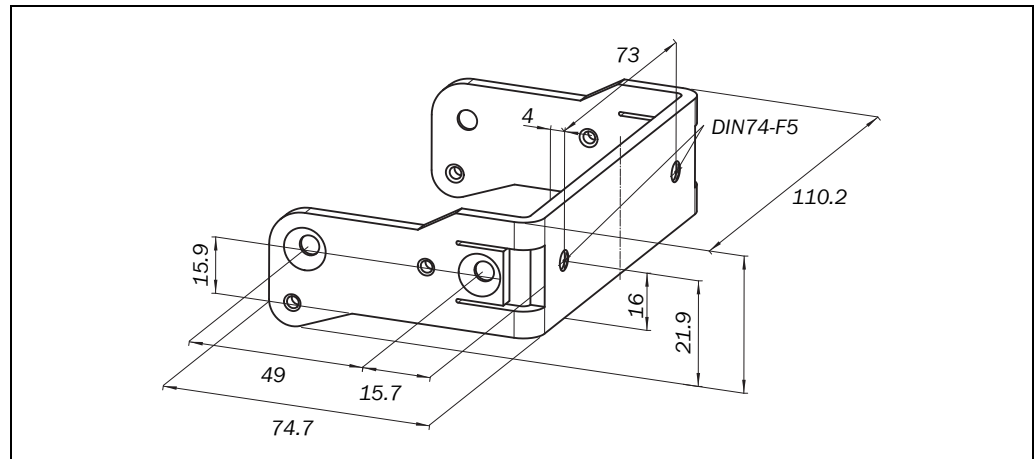

**S200**

Fig. 48: Dimensional drawing, mounting kit 1b

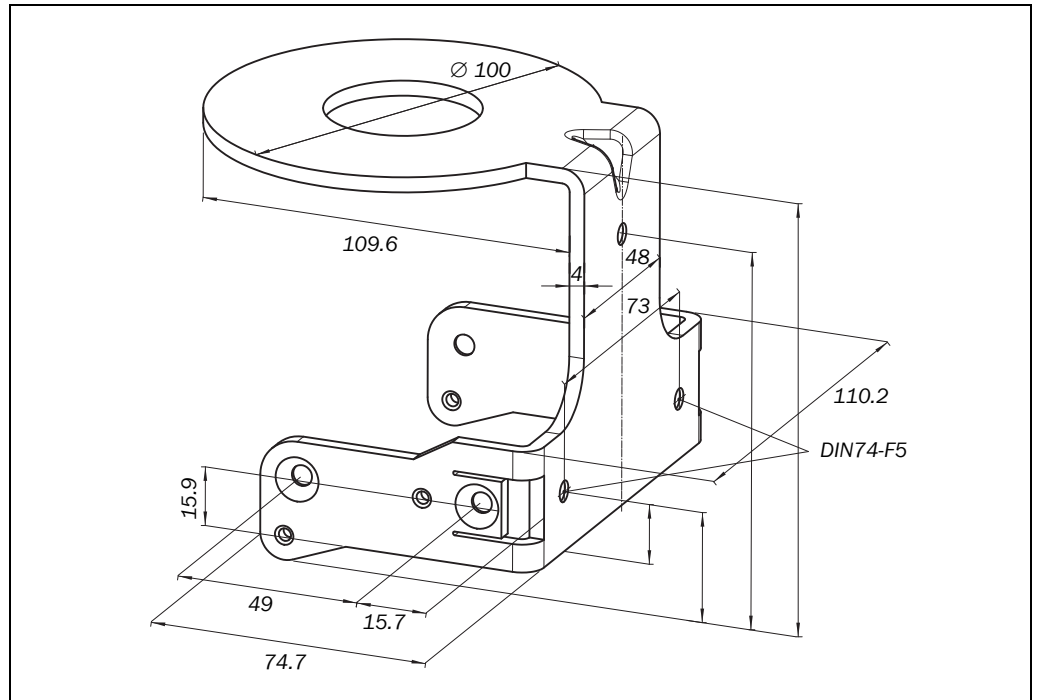

Fig. 49: Dimensional drawing, mounting kit 2

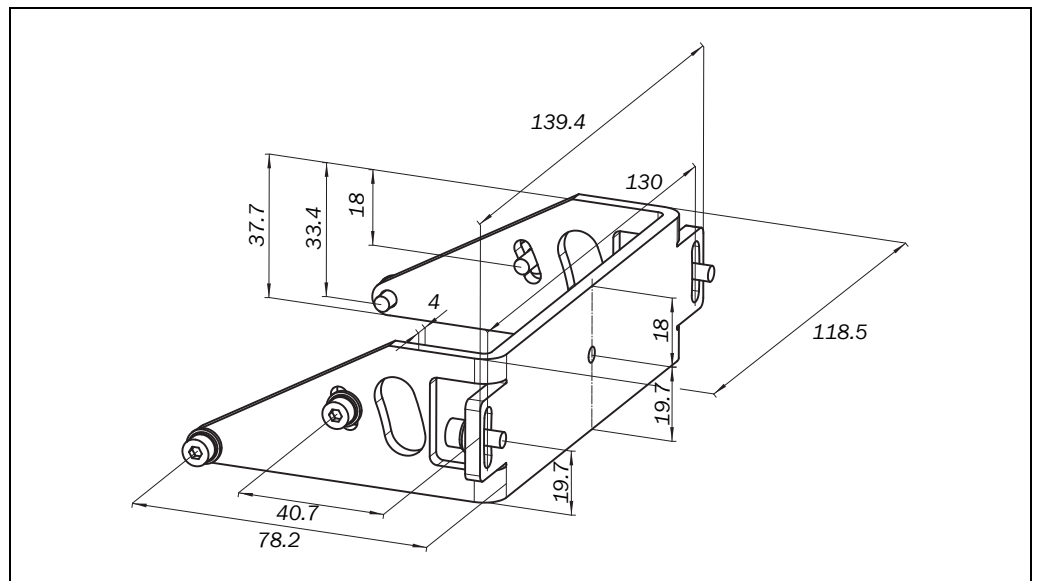
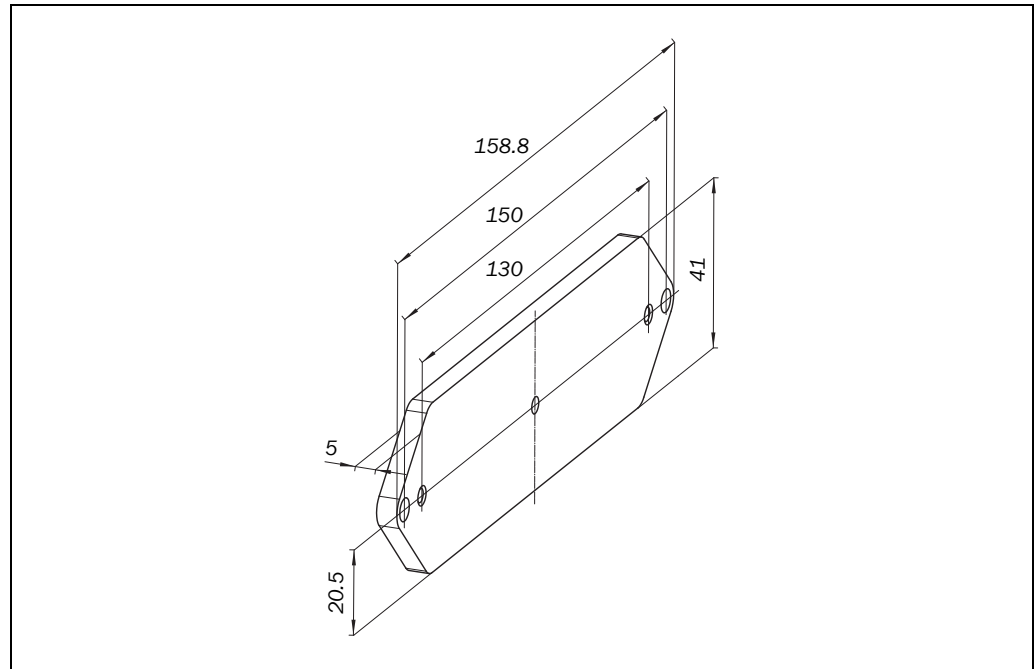
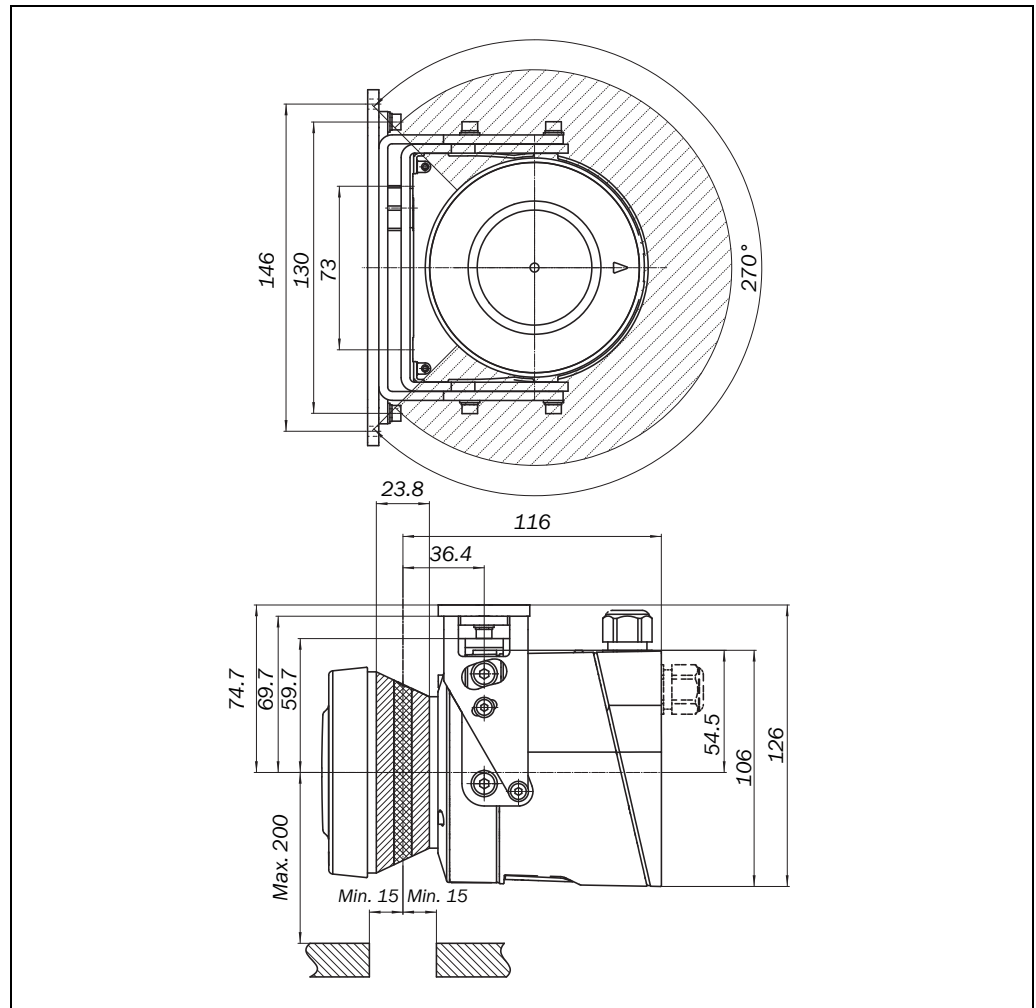

Fig. 50: Dimensional drawing, mounting kit 3



11.5.3 Scan plane origin

Fig. 51: Dimensional drawing of the scan plane with mounting kit 1a (mm)



# 12 Ordering information

## 12.1 Delivery S200

- safety laser scanner
- operating instructions and CDS (Configuration & Diagnostic Software) on CD-ROM
- information label Important information

**Note** System plugs not included.

System plugs without cable and pre-assembled system plugs are available from SICK AG (see section 12.3.2 “System plug” on page 77). For further information see section 5.2 “System plug assembly” on page 48 and section 5.3 “Pre-assembled system plugs” on page 49.

## 12.2 Available systems

Tab. 18: Part number of the system

Device type	Part	Part number
S20B-1011BA	S200	1026823

## 12.3 Accessories/spare parts

### 12.3.1 Mounting kits

Tab. 19: Part numbers mounting kit

Mounting kit	Description	Part number
1a	Mounting bracket for direct mounting at the rear on wall or machine.	2034324
1b	Mounting bracket for direct mounting at the rear on wall or machine, with protection for the optics cover.	2034325
2	Mounting bracket only in conjunction with mounting bracket 1a or 1b. Cross-wise adjustment possible.	2039302
3	Mounting plate only in conjunction with mounting bracket 2. Length-wise adjustment possible	2039303

### 12.3.2 System plug S200

Tab. 20: Part numbers system plugs S200

System plug	Features	Description	Part number
SX0B-A0000G	One M16 cable gland and one M12 blanking plug, on the rear	Without cable	2032807
SX0B-B1105G		Pre-assembled, 5 m long cable, 11 cores	2032859
SX0B-B1110G		Pre-assembled, 10 m long cable, 11 cores	2032860
SX0B-B1120G		Pre-assembled, 20 m long cable, 11 cores	2032861

**12.3.3 Service cable**

Tab. 21: Part numbers service cables

Part	Description	Part number
Service cable 2 m	For connecting the configuration connection to the serial interface on the PC M8, 4 pin/D-Sub 9 pin approx. 2 m	6021195
Service cable 8 m	For connecting the configuration connection to the serial interface on the PC M8, 4 pin/D-Sub 9 pin approx. 8 m	2027649

**12.3.4 Self assembly connecting cables**

Tab. 22: Part numbers connecting cables

Part	Part number
15-core, cross-section 0.56 mm <sup>2</sup> ( AWG 20) in 100-m reel	6030795

**12.3.5 On the documentation**

Tab. 23: Part numbers documentation

Part	Part number
CDS (Configuration & Diagnostic Software) for S200 on CD-ROM including online documentation and operating instructions in all available languages	2032314

**12.3.6 Safety relays**

Tab. 24: Part numbers safety relays

Part	Description	Part number
UE10-30S2	Safety relay UE10-30S with two screw type terminals	6024917
UE10-30S3	Safety relay UE10-30S with three plug-in terminals	6024918

**12.3.7 Safety controllers**

Tab. 25: Part numbers safety controllers

Part	Description	Part number
UE440-A0410	Safety controller for multifunctional applications	1023859
UE470-A0410	Safety controller for press applications	1023862

**12.3.8 Miscellaneous**

Tab. 26: Part numbers miscellaneous

Part	Description	Part number
Optics cover	Spare parts set for optics cover with replacement seal and screws	2039248
Plastic cleaner	Plastic cleaner and care product, anti-static, 1 litre	5600006
Lens cloth	Cloth for cleaning the optics cover	4003353
Power supply, 2.1 A	Power supply, 24 V DC, 2.1 A	7028789
Power supply, 3.9 A	Power supply, 24 V DC, 3.9 A	7028790

S200

# 13 Annex

## 13.1 Declaration of conformity

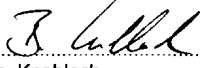
<h1>SICK</h1>		
<b>EC Declaration of conformity</b>		
en	Ident-No. : 9108160	
The undersigned, representing the following manufacturer		
<b>SICK AG</b> Industrial Safety Systems Sebastian-Kneipp-Straße 1 79183 Waldkirch Germany		
herewith declares that the product		
<table border="1"><tr><td style="text-align: center;"><b>S200</b></td></tr></table>		<b>S200</b>
<b>S200</b>		
is in conformity with the provisions of the following EC directive(s) (including all applicable amendments), and that the standards and/or technical specifications referenced overleaf have been applied.		
Waldkirch, <u>31.5.06</u>		
 ppa. Dr. Plasberg (Industrial Safety Systems) (Manager Research and Development)	 ppa. Knobloch (Industrial Safety Systems) (Manager Production)	

**Note** You can obtain the complete EC declaration of conformity via the SICK homepage on the Internet at: [www.sick.com](http://www.sick.com)

## 13.2 Manufacturer's checklist

# SICK

### Checklist for the manufacturer/installer for the installation of electro-sensitive protective equipment (ESPE)

Details about the points listed below must be present at least during initial commissioning – they are, however, dependent on the respective application, the specifications of which are to be controlled by the manufacturer/installer.

This checklist should be retained and kept with the machine documentation to serve as reference during recurring tests.

1. Have the safety rules and regulations been observed in compliance with the directives/standards applicable to the machine? Yes  No
2. Are the applied directives and standards listed in the declaration of conformity? Yes  No
3. Does the protective device fulfil the required PL/SILCL and PFHd according to EN ISO 13 849-1/EN 62 061 and the type according to EN 61 496-1? Yes  No
4. Is the access to the hazardous area/hazardous point only possible through the protective field of the ESPE? Yes  No
5. Have measures been taken to prevent and monitor unauthorised presence in the hazardous area when hazardous area/hazardous point protection (mechanical point-of-operation guarding), and have these been secured against removal? Yes  No
6. Are additional mechanical protective measures fitted and secured against manipulation which prevent reaching under, over or around the ESPE? Yes  No
7. Has the maximum stopping and/or stopping/run-down time of the machine been measured, specified and documented (at the machine and/or in the machine documentation)? Yes  No
8. Has the ESPE been mounted such that the required safety distance from the nearest hazardous point has been achieved? Yes  No
9. Are the ESPE devices correctly mounted and secured against manipulation after adjustment? Yes  No
10. Are the required protective measures against electric shock in effect (protection class)? Yes  No
11. Is the control switch for resetting the protective device (ESPE) or restarting the machine present and correctly installed? Yes  No
12. Are the outputs of the ESPE (OSSDs, AS-Interface Safety at Work) integrated in compliance with the required PL/SILCL according to EN ISO 13 849-1/EN 62 061 and does the integration comply with the circuit diagrams? Yes  No
13. Has the protective function been checked in compliance with the test notes of this documentation? Yes  No
14. Are the given protective functions effective at every setting of the operating mode selector switch? Yes  No
15. Are the switching elements activated by the ESPE, e.g. contactors, valves, monitored? Yes  No
16. Is the ESPE effective over the entire period of the dangerous state? Yes  No
17. Once initiated, will a dangerous state be stopped when switching the ESPE on or off and when changing the operating mode, or when switching to another protective device? Yes  No
18. Has the information label "Important Information" for the daily check been attached so that it is easily visible for the operator? Yes  No

**This checklist does not replace the initial commissioning, nor the regular inspection by qualified safety personnel.**



### 13.3 Glossary

<b>AOPDDR</b>	Active opto-electronic protective device responsive to diffuse reflection = active opto-electronic protective device responsive to diffuse reflection (e.g. S200, see also CLC/TS 61 496-3)
<b>External device monitoring (EDM)</b>	(External device monitoring) A device that electronically monitors the relay or contactor operated by the protective device prior to each new start.
<b>Field set</b>	Protective field and warning field form a pair, the so-called field set.
<b>Optics cover</b>	Plastic part with window for light output. The optics cover is available as a spare part.
<b>OSSD</b>	(Output signal switching device) The OSSD output is the switching output on the S200. This is a semiconductor output and is periodically tested for correct function. The S200 has two OSSD outputs that operate in parallel; for safety reasons these must be evaluated using two channels.
<b>Protective field</b>	The protective field secures the hazardous area on a machine or vehicle. As soon as the safety laser scanner detects an object in the protective field, it switches the OSSDs to the OFF state and thus initiates the shutdown of the machine or stop of the vehicle.
<b>Reflectivity</b>	Reflection of luminance. A measure of the reflectivity is the reflectance defined as the ratio of the luminance reflected from a surface in the measuring direction and the luminance of a completely matt white surface (white standard).
<b>Resolution/object resolution</b>	The minimum size of an object that is acquired by the protective device and is guaranteed by the manufacturer.
<b>Restart interlock</b>	The restart interlock is a protective device. In certain situations it prevents the machine from automatically restarting. This applies, e.g., after the scanner function has triggered during a dangerous machine state, after a change to the operating mode or the method of activation of the machine, or after the change to the start control device on the machine.
<b>Warning field</b>	The warning field is a field with a radius of up to 8 m (see section 11.1 "Characteristics" on page 64). Using this field larger areas can be controlled and simple switching functions (e.g. warning functions) triggered. The warning field is not allowed to be used for tasks related to personnel protection.

### 13.4 List of tables

Tab. 1:	Overview on disposal by components.....	12
Tab. 2:	Functions of the S200 .....	15
Tab. 3:	Maximum protective field ranges at different resolutions.....	23
Tab. 4:	Behaviour of the S200 on a contactor malfunction.....	25
Tab. 5:	Recommended multiple sampling .....	27
Tab. 6:	Advantages and disadvantages of mounting variations.....	33
Tab. 7:	Terminal assignment at the system plug.....	47
Tab. 8:	Pin assignment: pre-assembled system plug.....	49
Tab. 9:	7-segment display during and after the power up sequence on initial commissioning .....	53
Tab. 10:	LED indication after the power up sequence .....	54
Tab. 11:	7-segment display during and after the power up sequence on re-commissioning .....	54
Tab. 12:	LED indication after the power up sequence .....	55
Tab. 13:	Status indicators during operation.....	59
Tab. 14:	LED error messages.....	60
Tab. 15:	Error and status indications on the 7-segment display .....	61
Tab. 16:	Supplements for multiple sampling.....	65
Tab. 17:	Data sheet S200.....	68
Tab. 18:	Part number of the system.....	77
Tab. 19:	Part numbers mounting kit.....	77
Tab. 20:	Part numbers system plugs S200.....	77
Tab. 21:	Part numbers service cables .....	78
Tab. 22:	Part numbers connecting cables .....	78
Tab. 23:	Part numbers documentation .....	78
Tab. 24:	Part numbers safety relays.....	78
Tab. 25:	Part numbers safety controllers.....	78
Tab. 26:	Part numbers miscellaneous.....	78

### 13.5 List of illustrations

Fig. 1:	Device components .....	14
Fig. 2:	Principle of operation, time of flight measurement by the S200.....	16
Fig. 3:	Principle of operation, rotation of the S200.....	16
Fig. 4:	Protective field, warning field and distance measuring range .....	17
Fig. 5:	Hazardous area protection with one monitored area .....	18
Fig. 6:	Point-of-operation guarding.....	19
Fig. 7:	Hazardous point protection .....	19
Fig. 8:	Access protection.....	20
Fig. 9:	Reading protective field or warning field .....	22
Fig. 10:	Schematic diagram of contour as reference .....	23
Fig. 11:	Contour as reference for vertical operation.....	24

Fig. 12: Contour as reference for horizontal operation.....	24
Fig. 13: Schematic outline of the operation with restart interlock.....	26
Fig. 14: Status indicators on the S200.....	28
Fig. 15: Horizontal stationary application.....	31
Fig. 16: Safety distance S.....	32
Fig. 17: Mounting variations for the scan plane.....	33
Fig. 18: Relationship between resolution and protective field mounting height.....	34
Fig. 19: Access protection.....	35
Fig. 20: Safety distance to the hazardous area.....	37
Fig. 21: Unprotected areas.....	39
Fig. 22: Preventing unprotected areas.....	39
Fig. 23: Prevent crawling beneath, standing behind, climbing over.....	40
Fig. 24: Direct mounting.....	41
Fig. 25: Mounting with mounting kit 1a.....	41
Fig. 26: Mounting with mounting kit 1b incl. protection for the optics cover.....	42
Fig. 27: Mounting with mounting kit 2.....	43
Fig. 28: Opposite mounting.....	44
Fig. 29: Offset parallel mounting.....	44
Fig. 30: Mounting on a cross.....	44
Fig. 31: Reverse mounting, parallel offset.....	44
Fig. 32: Reverse mounting of two S200, with parallel offset.....	45
Fig. 33: Reverse mounting of one S200, with parallel offset.....	45
Fig. 34: Screw terminal strip on the system plug.....	47
Fig. 35: System plug SXOB-A0000G.....	48
Fig. 36: Hazardous area protection.....	50
Fig. 37: Access protection.....	50
Fig. 38: Connection diagrams for restart interlock and external device monitoring.....	51
Fig. 39: Configuration connection.....	52
Fig. 40: Undo the fixing screws for the front screen.....	58
Fig. 41: Diagram of scanning ranges for various reflectances.....	64
Fig. 42: Diagram of the test pulses at the OSSDs.....	66
Fig. 43: Voltage test after switching on the OSSDs.....	67
Fig. 44: Shut-down test.....	67
Fig. 45: Voltage test.....	67
Fig. 46: S200 dimensional drawing (mm).....	74
Fig. 47: Dimensional drawing, mounting kit 1a.....	74
Fig. 48: Dimensional drawing, mounting kit 1b.....	75
Fig. 49: Dimensional drawing, mounting kit 2.....	75
Fig. 50: Dimensional drawing, mounting kit 3.....	76
Fig. 51: Dimensional drawing of the scan plane with mounting kit 1a (mm).....	76

**Australia**

Phone +61 3 9497 4100  
1800 33 48 02 – tollfree  
E-Mail sales@sick.com.au

**Belgium/Luxembourg**

Phone +32 (0)2 466 55 66  
E-Mail info@sick.be

**Brasil**

Phone +55 11 3215-4900  
E-Mail sac@sick.com.br

**Ceská Republika**

Phone +420 2 57 91 18 50  
E-Mail sick@sick.cz

**China**

Phone +852-2763 6966  
E-Mail ghk@sick.com.hk

**Danmark**

Phone +45 45 82 64 00  
E-Mail sick@sick.dk

**Deutschland**

Phone +49 211 5301-301  
E-Mail kundenservice@sick.de

**España**

Phone +34 93 480 31 00  
E-Mail info@sick.es

**France**

Phone +33 1 64 62 35 00  
E-Mail info@sick.fr

**Great Britain**

Phone +44 (0)1727 831121  
E-Mail info@sick.co.uk

**India**

Phone +91-22-4033 8333  
E-Mail info@sick-india.com

**Israel**

Phone +972-4-999-0590  
E-Mail info@sick-sensors.com

**Italia**

Phone +39 02 27 43 41  
E-Mail info@sick.it

**Japan**

Phone +81 (0)3 3358 1341  
E-Mail support@sick.jp

**Nederlands**

Phone +31 (0)30 229 25 44  
E-Mail info@sick.nl

**Norge**

Phone +47 67 81 50 00  
E-Mail austefjord@sick.no

**Österreich**

Phone +43 (0)22 36 62 28 8-0  
E-Mail office@sick.at

**Polska**

Phone +48 22 837 40 50  
E-Mail info@sick.pl

**Republic of Korea**

Phone +82-2 786 6321/4  
E-Mail kang@sickkorea.net

**Republika Slovenija**

Phone +386 (0)1-47 69 990  
E-Mail office@sick.si

**România**

Phone +40 356 171 120  
E-Mail office@sick.ro

**Russia**

Phone +7 495 775 05 34  
E-Mail info@sick-automation.ru

**Schweiz**

Phone +41 41 619 29 39  
E-Mail contact@sick.ch

**Singapore**

Phone +65 6744 3732  
E-Mail admin@sicksgp.com.sg

**Suomi**

Phone +358-9-25 15 800  
E-Mail sick@sick.fi

**Sverige**

Phone +46 10 110 10 00  
E-Mail info@sick.se

**Taiwan**

Phone +886 2 2375-6288  
E-Mail sales@sick.com.tw

**Türkiye**

Phone +90 216 587 74 00  
E-Mail info@sick.com.tr

**United Arab Emirates**

Phone +971 4 8865 878  
E-Mail info@sick.ae

**USA/Canada/México**

Phone +1(952) 941-6780  
1 800-325-7425 – tollfree  
E-Mail info@sickusa.com

More representatives and agencies  
in all major industrial nations at  
[www.sick.com](http://www.sick.com)