



## GM700

### Laser Gas Analyzer

EFFICIENT PROCESS ANALYSIS –  
EVEN UNDER DIFFICULT CONDITIONS

In-situ gas analyzers

**SICK**  
Sensor Intelligence.



Measuring difficult, selective gas components such as ammonia ( $\text{NH}_3$ ), hydrogen fluoride (HF), and hydrogen chloride (HCl) is a major challenge for process analysis and emission monitoring. The GM700 in-situ gas analyzer opens up new options here. With unparalleled flexibility – without the need for test gases.

### Technology and principle of operation

The GM700 gas analyzer operates reliably and efficiently. Thanks to its innovative in-situ measuring technology, the analyzer can be mounted at the measurement location directly in the duct through which the gas flows. The benefits: time and cost savings thanks to simple installation and commissioning, low maintenance requirements, and very short response

times. The GM700 delivers a high-resolution measurement using direct laser spectroscopy (see below) with a precisely adjusted spectral line. The result: fast and undistorted recording of measuring gas concentrations without time-consuming gas extraction, conditioning, and cost-intensive transportation. Gas components that can be measured by the GM700 include:

#### Laser spectroscopy (tunable diode laser spectroscopy, TDLS)

In laser spectroscopy, the laser beam from the sender is sent through the gas to be measured to the reflector. From there, it is reflected back to a sensitive detector (photo diode) in the sender/receiver unit. The wavelength of the laser diode is adjusted to a spectral line of the measuring gas component. This is scanned by modulating the wavelength and recorded by the photo diode of the detector. A signal evaluation then provides the gas concentration based on the wavelength-specific absorption of the measurement signal. The TDLS principle therefore allows gas components in a gas mixture to be measured selectively.

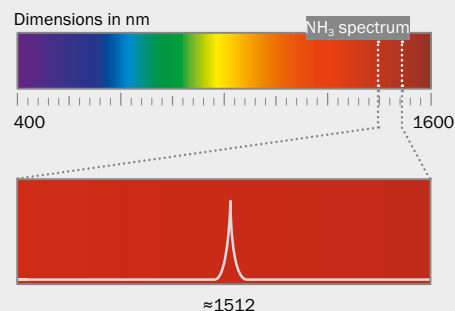

## Product versions

### GM700 – version with measuring probe



#### System components

- Sender/receiver unit with optical and electronic modules
- Measuring probe with purge air attachment as version with an open measuring path (GMP) or as a gas diffusion probe (GPP)
- Evaluation unit for outputting measured values and performing the control and monitoring function

#### Optional components

- Purge air unit
- Weather protection covers
- Flange with tube for mounting

#### Benefits

- Access to the duct from one side and easy installation
- Integrated zero-point path
- Application adjustment irrespective of duct dimensions and plant conditions
- Drift and calibration-free

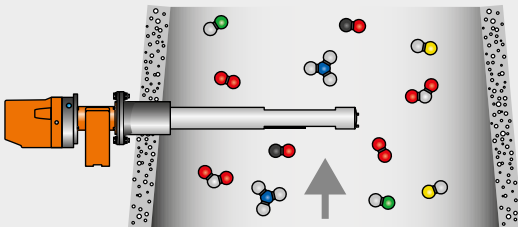

### GM700 – cross duct version



#### System components

- Sender/receiver unit with optical and electronic modules
- Reflector unit with triple reflector and purge air attachment
- Evaluation unit for outputting measured values and performing the control and monitoring function

#### Optional components

- Purge air unit
- Weather protection covers
- Flange with tube for mounting
- Zero-point comparison path

#### Benefits

- Representative measurement results due to measurement across the entire duct cross section
- Drift and calibration-free
- Particularly low maintenance

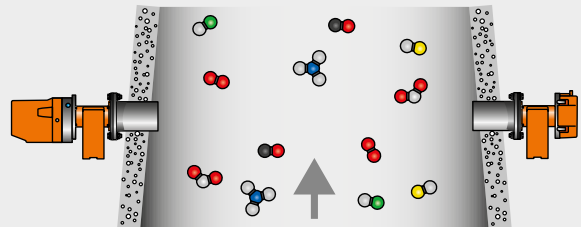

# EFFICIENT PROCESS ANALYSIS – EVEN UNDER DIFFICULT CONDITIONS

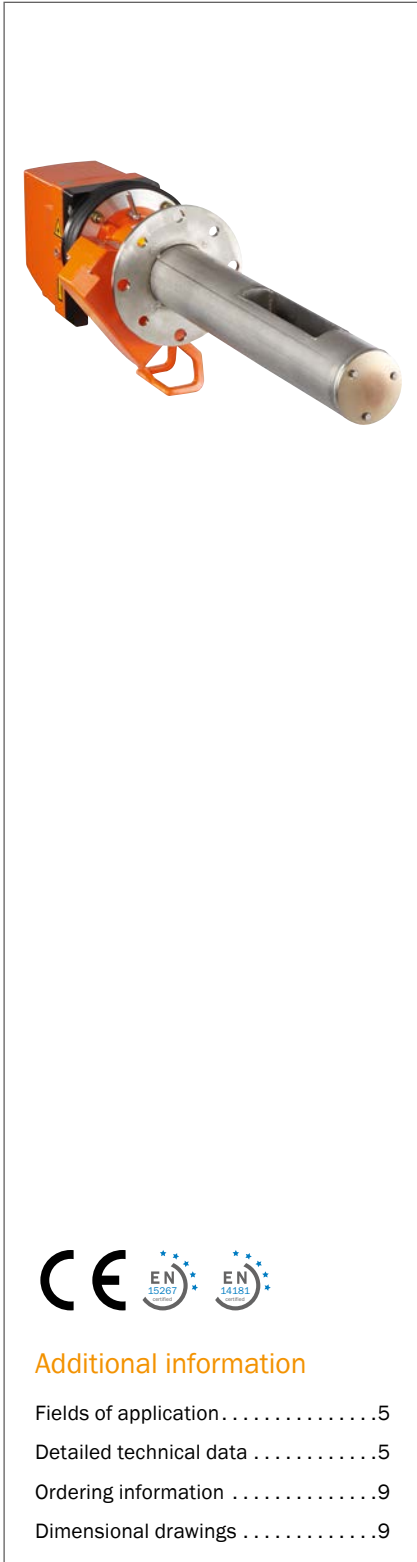

## Product description

High reliability and precision as well as minimal response times are the distinguishing features of the GM700 laser gas analyzer. Based on the principle of TDLS (Tunable Diode Laser Spectroscopy) and by using specific light absorp-

tion, the GM700 is able to measure several gas components, such as NH<sub>3</sub>, HF, HCl or H<sub>2</sub>O. The in-situ measurement is ideal for the fast determination of gas concentrations in process control and emission monitoring.

## At a glance

- High selectivity due to high spectral resolution
- Short response times
- No calibration required
- No moving parts: minimal wear and tear
- No gas sampling and conditioning required

## Your benefits

- Unbiased measuring values due to in-situ measurement directly in the process
- Best application solution using probe or cross-duct type
- High reliability during operation
- Also applicable for harsh environment conditions
- Detection of fast and short-term process fluctuations



## Additional information

Fields of application . . . . .5  
 Detailed technical data . . . . .5  
 Ordering information . . . . .9  
 Dimensional drawings . . . . .9

→ [www.mysick.com/en/GM700](http://www.mysick.com/en/GM700)

For more information, just enter the link and get direct access to technical data, CAD design models, operating instructions, software, application examples and much more.

## Fields of application

- Ammonia slip measurement in DeNOx plants
- Emission monitoring of hydrogen fluoride in aluminum smelters
- Ammonia measurement in exhaust gas of combustion engines
- Ammonia measurement in urea production or composting plants
- HCl measurement in combustion plants
- HF measurement in ceramic industry

## Detailed technical data

The exact device specifications and performance data of the product may deviate from the information provided here, and depend on the application in which the product is being used and the relevant customer specifications.

### System

<b>Measured values</b>		NH <sub>3</sub> , HF, HCl, H <sub>2</sub> O
<b>Performance-tested measurands</b>		HF
<b>Measurement principles</b>		Diode laser spectroscopy (TDLS)
<b>Length of measuring path</b>		Cross-duct version: 0.5 m ... 6 m Depending on application Open measuring probe (GMP): 0.25 mm ... 1.5 m Depending on application Gas-testable measuring probe (GPP): 0.227 m ... 0.977 m Depending on application
<b>Measuring ranges</b>		NH <sub>3</sub> 0 ... 25 ppm / 0 ... 4,000 ppm HF 0 ... 5 ppm / 0 ... 2,000 ppm HCl 0 ... 10 ppm / 0 ... 3,000 ppm Measuring ranges refer to 1 m measuring path Measuring ranges depend on application and device version
<b>Dual measuring ranges</b>		HCl / H <sub>2</sub> O 0 ... 10 ppm / 0 ... 3,000 ppm (HCl) 0 ... 50 Vol.-% / 0 ... 100 Vol.-% (H <sub>2</sub> O) NH <sub>3</sub> / H <sub>2</sub> O 0 ... 25 ppm / 0 ... 4,000 ppm (NH <sub>3</sub> ) 0 ... 20 Vol.-% / 0 ... 20 Vol.-% (H <sub>2</sub> O) NH <sub>3</sub> / H <sub>2</sub> O high humidity 0 ... 25 ppm / 0 ... 100 ppm (NH <sub>3</sub> ) 0 ... 40 Vol.-% / 0 ... 40 Vol.-% (H <sub>2</sub> O high humidity) Measuring ranges refer to 1 m measuring path Measuring ranges depend on application and device version
<b>Certified measuring ranges</b>		HF 0 ... 5 mg/m <sup>3</sup> / 0 ... 25 mg/m <sup>3</sup> Only the cross-duct version is type approved
<b>Response time</b>		1 s ... 360 s Adjustable
<b>Accuracy</b>		Zero point: ≤ ± 2 % Relative to measuring range end value Sensitivity: ≤ ± 2 % Within the maintenance interval (6 months), relative to measuring range full scale
<b>Process temperature</b>		-40 °C ... +200 °C Depending on device version
<b>Ambient temperature</b>		-40 °C ... +50 °C Depends on parameterization; temperature change max. ±10 °C/h
<b>Storage temperature</b>		-40 °C ... +55 °C
<b>Ambient humidity</b>		≤ 85 % Relative humidity; non-condensing

<b>Conformities</b>	Approved for plants requiring approval 2001/80/EC (13. BImSchV) 2000/76/EC (17. BImSchV) 27. BImSchV German Clean Air Regulations EN 15267 EN 14181 Only for HF
<b>Electrical safety</b>	CE
<b>Test functions</b>	Automatic check cycle for zero and span point (only for NH <sub>3</sub> and HCl)

### Sender/receiver unit

<b>Description</b>	Analyzer unit of the measuring system
<b>Enclosure rating</b>	IP 65
<b>Dimensions (W x H x D)</b>	239 mm x 272 mm x 330 mm
<b>Weight</b>	13 kg
<b>Power supply</b>	
Voltage	Supply via evaluation unit: 24 V DC
<b>Auxiliary gas connections</b>	Test gas: Swagelok 1/4" Purge gas: Swagelok 1/4"

### Open measuring probe (GMP)

<b>Description</b>	Measuring probe in open design with integrated purge air control system
<b>Process temperature</b>	-40 °C ... +250 °C
<b>Process pressure</b>	Depending on purge air supply
<b>Process gas humidity</b>	Non-condensing
<b>Enclosure rating</b>	IP 65
<b>Dimensions (W x H x D)</b>	See dimensional drawings
<b>Weight</b>	25 kg
<b>Power supply</b>	
Voltage	Supply via evaluation unit: 24 V DC
<b>Integrated components</b>	Flow monitor (monitoring of purge air feed) PT1000 temperature sensor (measurement of gas temperature) Pressure sensor

### Gas-testable measuring probe (GPP)

<b>Description</b>	Measuring probe with gas permeable filter element for adjustment with test gas
<b>Process temperature</b>	HCl: +130 °C ... +430 °C NH <sub>3</sub> : +300 °C ... +430 °C
<b>Process pressure</b>	120 hPa
<b>Enclosure rating</b>	IP 65
<b>Dimensions (W x H x D)</b>	See dimensional drawings
<b>Weight</b>	45 kg
<b>Power supply</b>	
Voltage	150 V / 230 V
Frequency	50 Hz / 60 Hz
Power consumption	≤ 150 W
<b>Integrated components</b>	PT1000 temperature sensor (measurement of gas temperature) Pressure sensor Heating of optical interfaces

## Reflector unit (cross-duct version)

<b>Description</b>	Reflector unit with hollow triple reflector
<b>Process temperature</b>	≤ +200 °C
<b>Process gas humidity</b>	Non-condensing
<b>Enclosure rating</b>	IP 65
<b>Dimensions (W x H x D)</b>	291 mm x 280 mm x 161 mm
<b>Weight</b>	7 kg

## GM700 evaluation unit; steel sheet enclosure

<b>Description</b>	The evaluation unit serves as user interface and is responsible for data processing and output as well as control and monitoring functions	
<b>Enclosure rating</b>	IP 65 / NEMA 4x	
<b>Analog outputs</b>	3 outputs: 0/4 ... 20 mA, 500 Ω Electrically isolated	
<b>Analog inputs</b>	2 inputs: 0 ... 20 mA, 100 Ω For gas temperature and gas pressure	
<b>Digital outputs</b>	3 relay contacts: 48 V AC, 1 A, 60 W / 48 V DC, 1 A, 30 W	
<b>Digital inputs</b>	3 inputs: 24 V	
<b>Interfaces and bus protocols</b>	RS-232	Proprietary service interface
<b>Indication</b>	LC display Status LEDs: "Operation", "Service", "Warning" and "Malfunction"	
<b>Input</b>	Arrow keys Functional keys	
<b>Model</b>	Steel sheet enclosure	
<b>Dimensions (W x H x D)</b>	200 mm x 346 mm x 97.5 mm	
<b>Weight</b>	≤ 4.7 kg	
<b>Power supply</b>	Voltage	115 V / 230 V
	Frequency	50 Hz / 60 Hz
	Power consumption	≤ 50 W

## GM700 evaluation unit; cast metal enclosure

<b>Description</b>	The evaluation unit serves as user interface and is responsible for data processing and output as well as control and monitoring functions	
<b>Enclosure rating</b>	IP 67/NEMA 6	
<b>Analog outputs</b>	3 outputs: 0/4 ... 20 mA, 500 Ω Electrically isolated	
<b>Analog inputs</b>	2 inputs: 0 ... 20 mA, 100 Ω For gas temperature and gas pressure	
<b>Digital outputs</b>	3 relay contacts: 48 V AC, 1 A, 60 W / 48 V DC, 1 A, 30 W	
<b>Digital inputs</b>	3 inputs: 24 V	
<b>Interfaces and bus protocols</b>	RS-232	Proprietary service interface
<b>Indication</b>	LC display Status LEDs: "Operation", "Service", "Warning" and "Malfunction"	

<b>Input</b>	Arrow keys Functional keys
<b>Model</b>	Cast metal enclosure
<b>Dimensions (W x H x D)</b>	289 mm x 370 mm x 138 mm
<b>Weight</b>	≤ 8.6 kg
<b>Power supply</b>	
	Voltage 115 V / 230 V
	Frequency 50 Hz / 60 Hz
	Power consumption ≤ 50 W

### Connection unit

<b>Description</b>	To lengthen the internal CAN-Bus connection with cable provided by the customer
<b>Dimensions (W x H x D)</b>	175 mm x 110.5 mm x 175 mm
<b>Weight</b>	3 kg
<b>Power supply</b>	
	Voltage 115 V / 230 V
	Frequency 50 Hz / 60 Hz
<b>Integrated components</b>	Integrated 24 V power supply for sender/receiver unit

### Purge air fixture

<b>Description</b>	Fixture to flanges with connections for purge air hose and temperature sensor
<b>Dimensions (W x H x D)</b>	420 mm x 429 mm x 220 mm
<b>Weight</b>	7 kg
<b>Auxiliary gas connections</b>	Purge air: Hose nozzle 40 mm
<b>Electrical connections</b>	Flow monitor PT1000 temperature sensor

### SLV4-2 purge air unit, 2BH1300, 3-ph

<b>Description</b>	Unit to provide dust-free air for flushing of optical surfaces
<b>Gas flow rate</b>	38 m <sup>3</sup> /h ... 63 m <sup>3</sup> /h At 30 hPa counter pressure, depending on low pressure inside the filter
<b>Ambient temperature</b>	-20 °C ... +40 °C
<b>Enclosure rating</b>	IP 54
<b>Dimensions (W x H x D)</b>	550 mm x 550 mm x 258 mm (for details see dimensional drawings)
<b>Weight</b>	18 kg
<b>Power supply</b>	
	Three-phase current
	3-phase, Δ: 200 ... 240 V, 50 Hz, 2.6 A, 350 W
	3-phase, Δ: 220 ... 275 V, 60 Hz, 2.3 A, 450 W
	3-phase, Y: 345 ... 415 V, 50 Hz, 1.5 A, 350 W
	3-phase, Y: 380 ... 480 V, 60 Hz, 1.3 A, 450 W
<b>Auxiliary gas connections</b>	Purge air: 40 mm
<b>Test functions</b>	Low pressure controller (switch point -35 hPa)
<b>Integrated components</b>	2-step air filter, type Europiclön, dust capacity 200 g



### Ordering information

Our regional sales organization will help you to select the optimum device configuration.

### Dimensional drawings (Dimensions in mm (inch))

GM700 sender/receiver unit

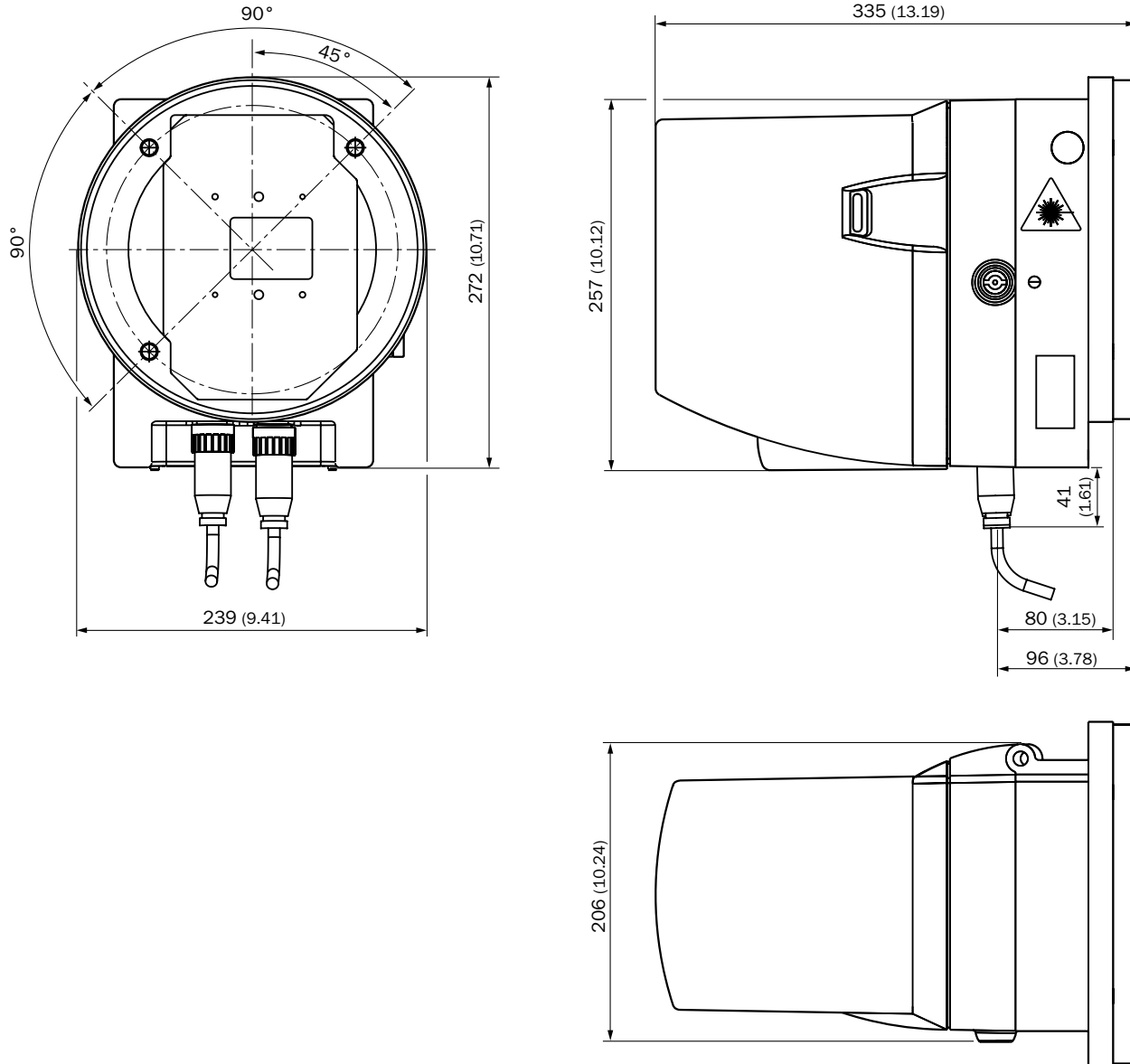

Open measuring probe (GMP)

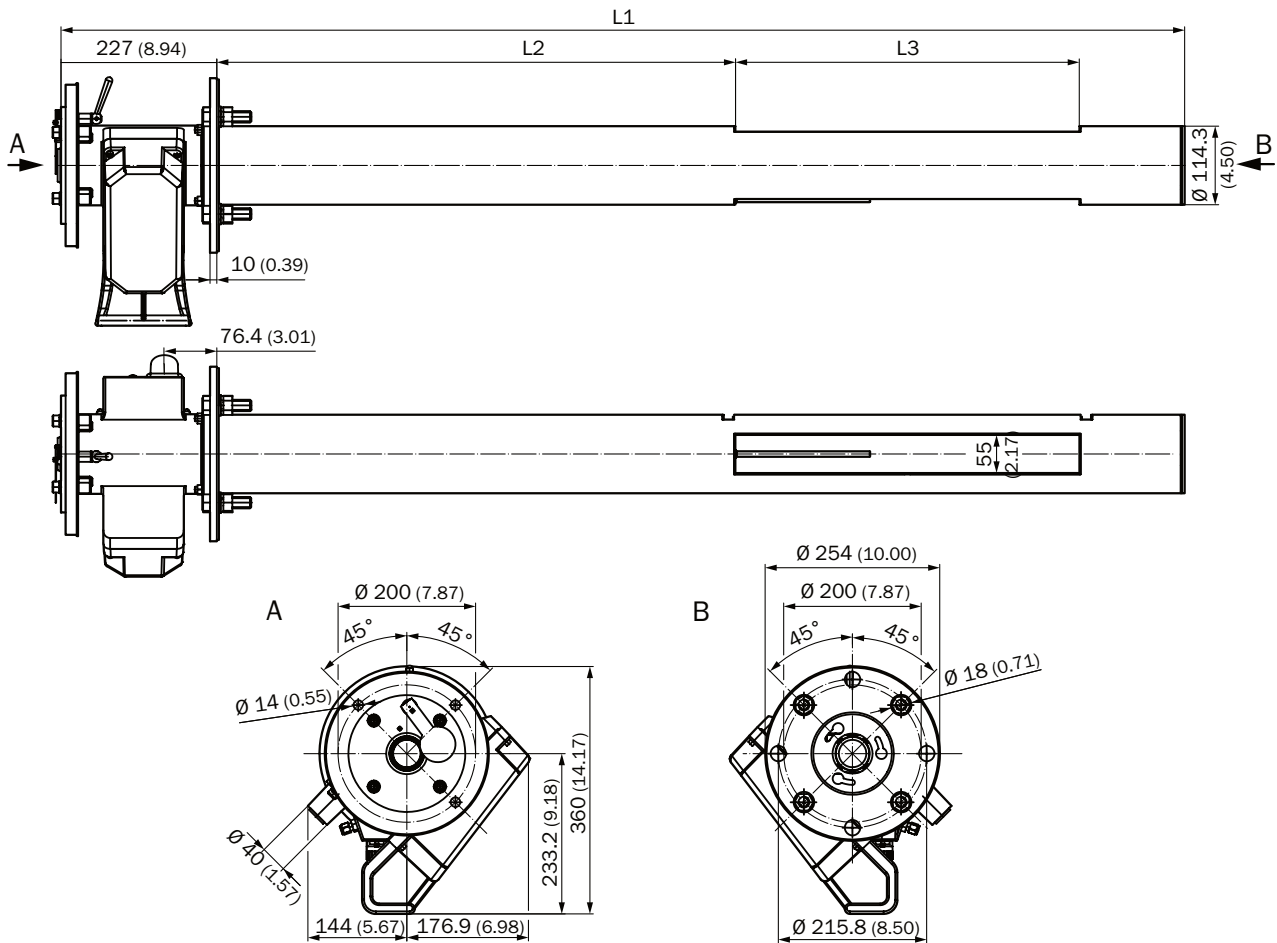

GMP measuring probes		Measuring gap L3 (active measuring path)					
Probe length, nominal	L1	250 (9.84)	500 (19.69)	750 (29.53)	1,000 (39.37)	1,250 (49.21)	1,500 (59.06)
		L2					
900 (35.43)	935 (36.81)	296 (11.65)	46 (1.81)	---	---	---	---
1,500 (59.06)	1,644 (64.72)	1,004.5 (39.55)	754.5 (29.70)	504.5 (19.86)	254.5 (10.02)	---	---
2,000 (78.74)	2,128 (83.78)	1,489 (58.62)	1,239 (48.78)	989 (38.94)	739 (29.09)	489 (19.25)	239 (9.41)

**All dimensions in mm (inch)**  
Application specific lengths on request

Gas-testable measuring probe (GPP)

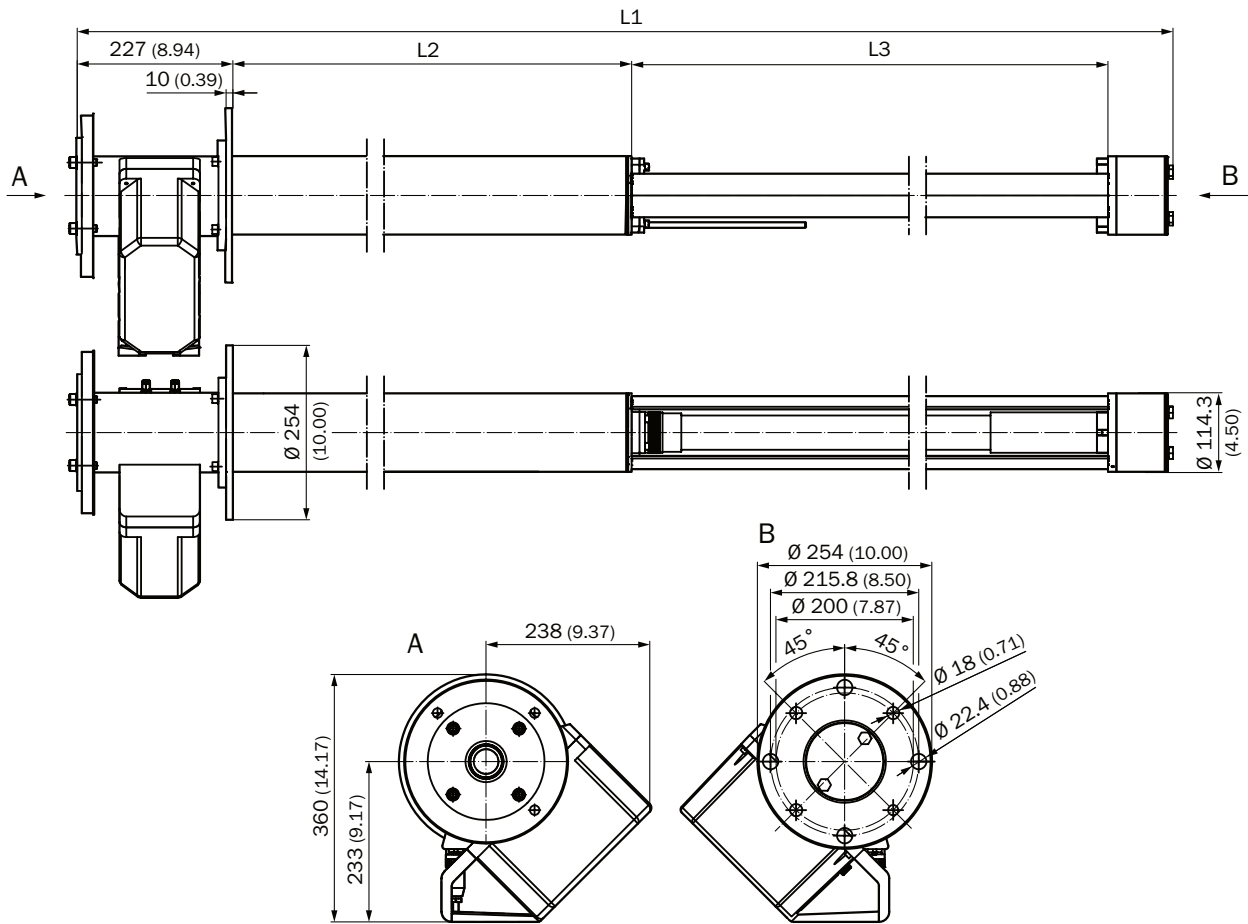

GPP measuring probes		Measuring gap L3 (active measuring path)			
		227 (8.94)	477 (18.78)	727 (28.62)	977 (38.46)
Probe length, nominal	L1	L2			
<b>1,000 (39.37)</b>	904 (35.59)	353 (13.90)	103 (4.06)	---	---
<b>1,500 (59.06)</b>	1,614 (63.54)	1,063 (41.85)	813 (32.01)	563 (22.17)	313 (12.32)
<b>2,000 (78.74)</b>	2,098 (82.60)	1,547 (60.91)	1,297 (51.06)	1,047 (41.22)	797 (31.38)
<b>All dimensions in mm (inch)</b>					
Application specific lengths on request					

GM700 reflector unit

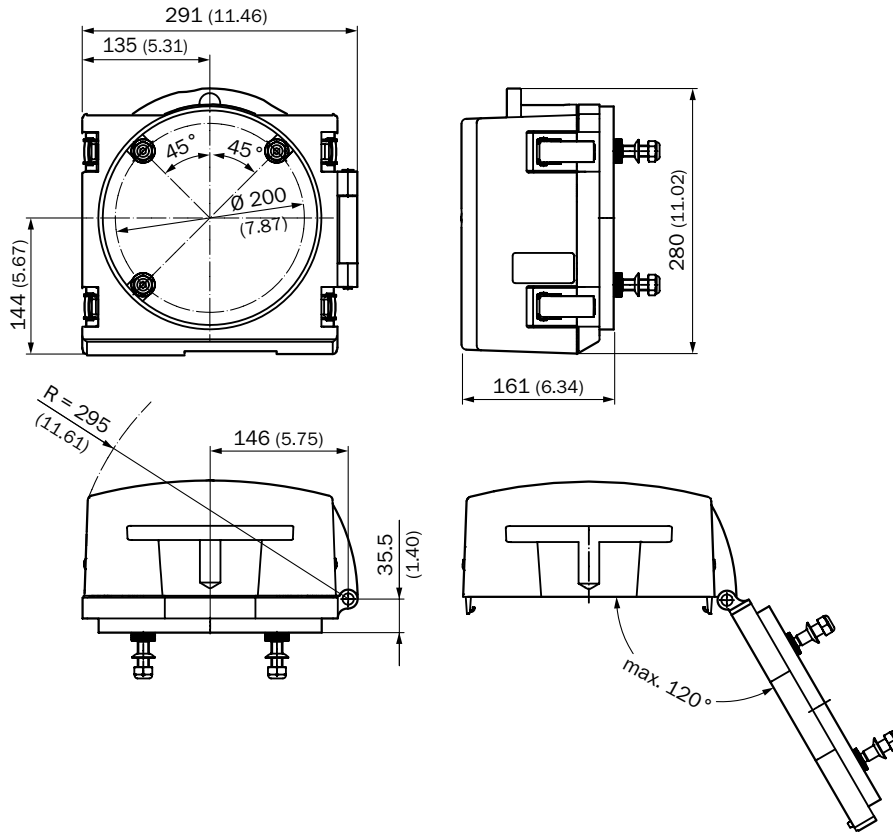

Evaluation unit; steel sheet enclosure

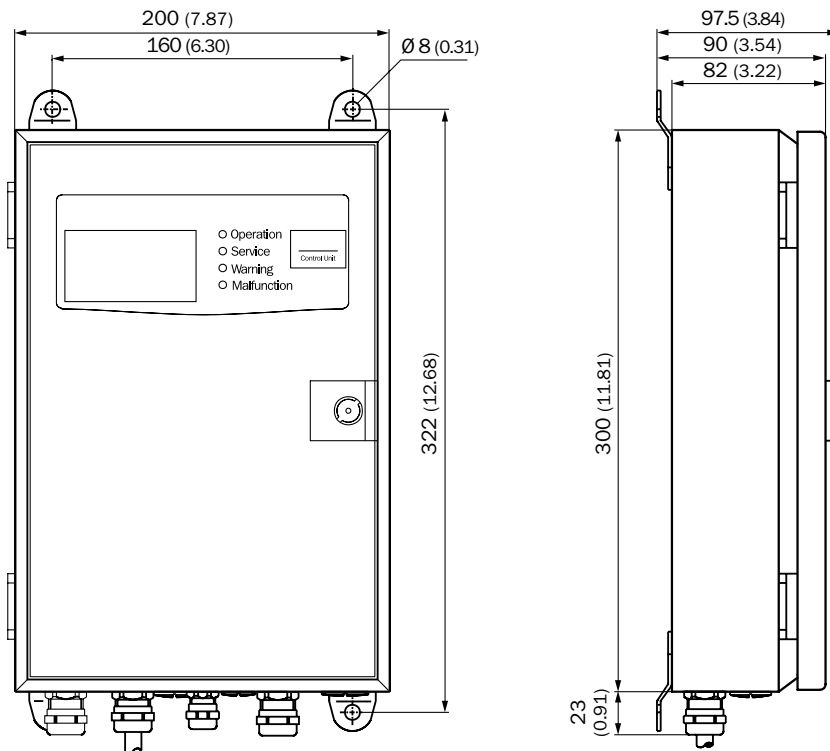

GM700 evaluation unit cast metal enclosure

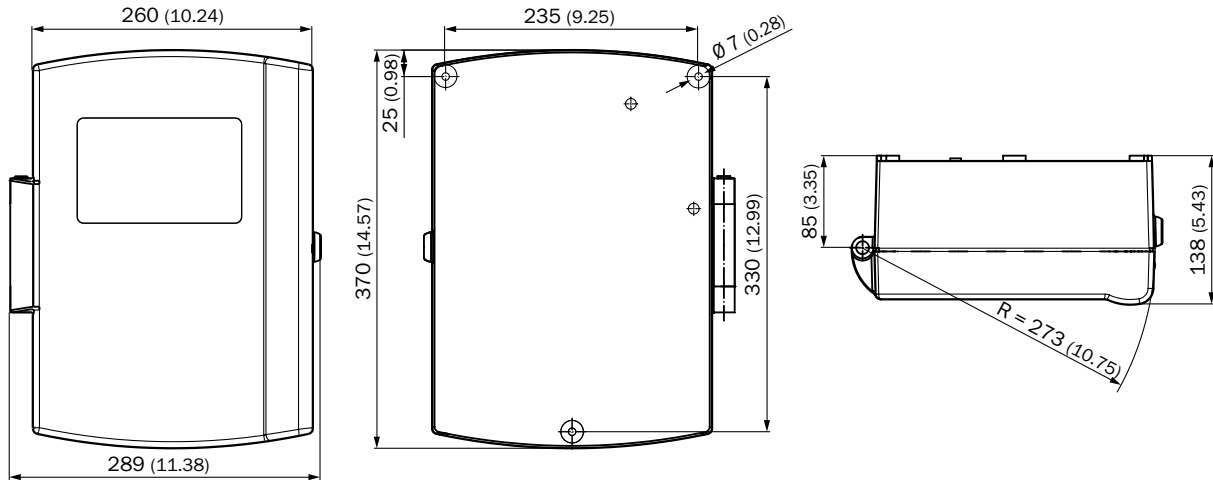

GM700 connection unit

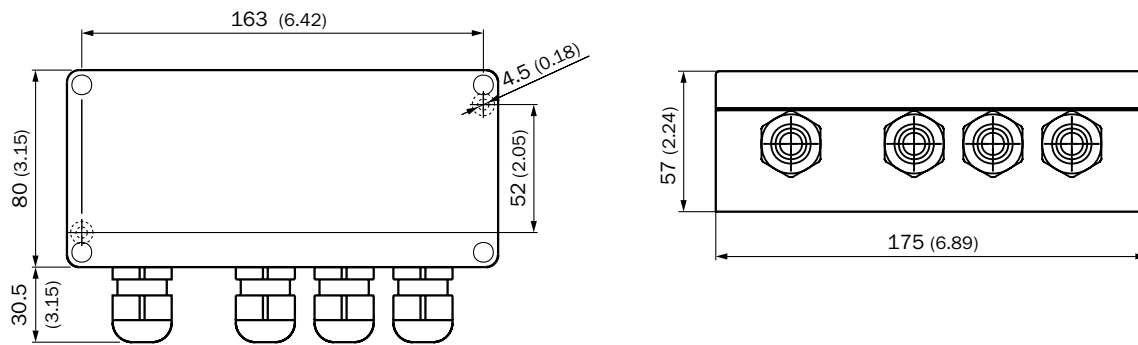

SLV4-2 purge air unit, 2BH1300

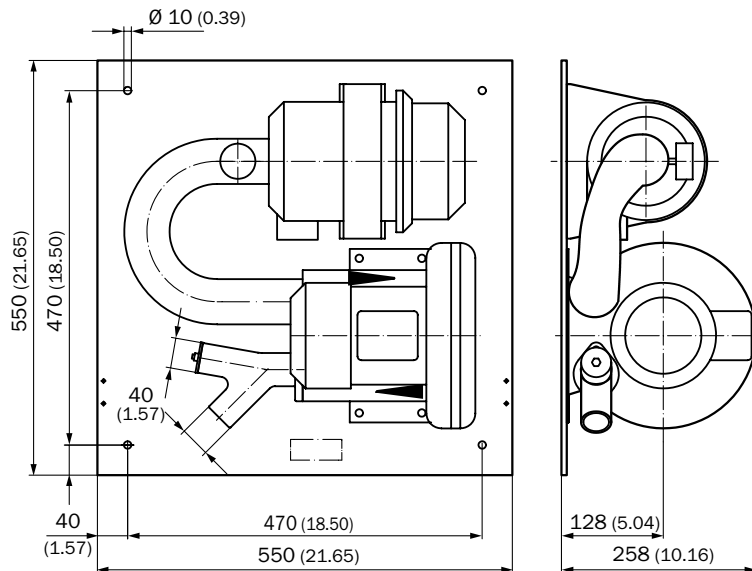

Mounting flange,  $D_i=125$  mm

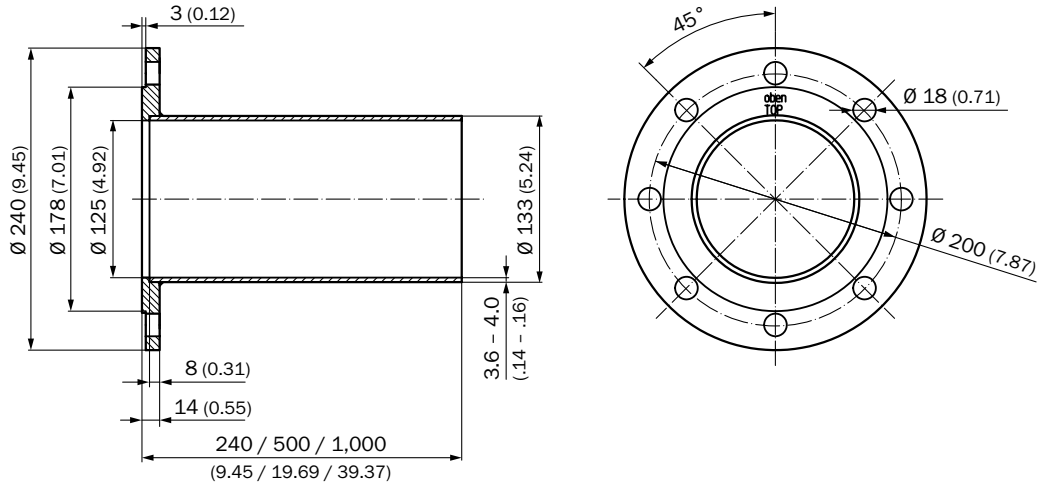

Mounting flange,  $D_i=125$  mm only for cross-duct version

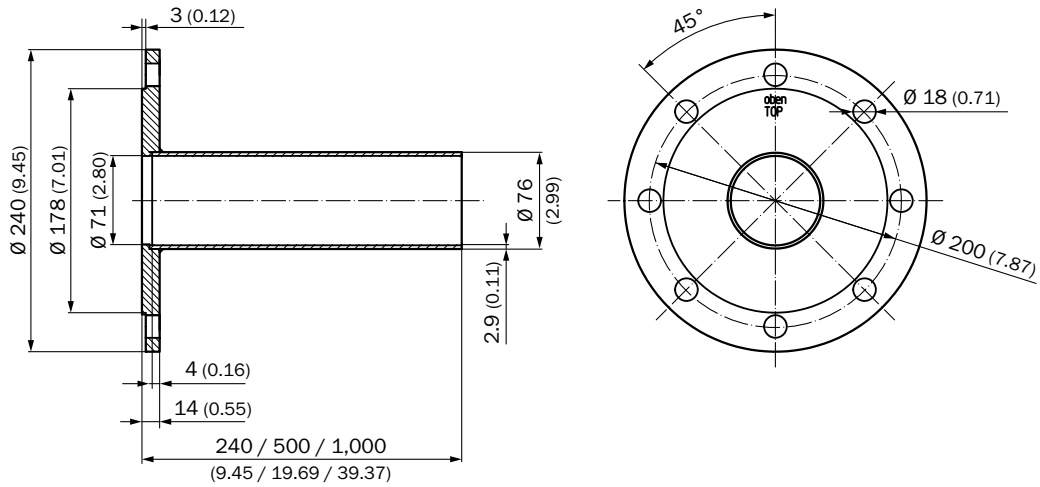

## REGISTER AT WWW.SICK.COM TODAY AND ENJOY ALL THE BENEFITS



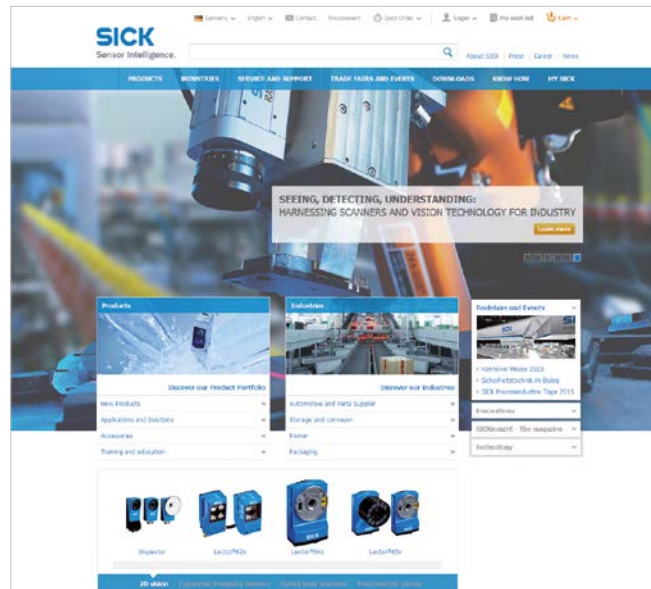

- ✔ Select products, accessories, documentation and software quickly and easily.
- ✔ Create, save and share personalized wish lists.
- ✔ View the net price and date of delivery for every product.
- ✔ Requests for quotation, ordering and delivery tracking made easy.
- ✔ Overview of all quotations and orders.
- ✔ Direct ordering: submit even very complex orders in moments.
- ✔ View the status of quotations and orders at any time. Receive e-mail notifications of status changes.



## SERVICES FOR MACHINES AND SYSTEMS: SICK LifeTime Services

Our comprehensive and versatile LifeTime Services are the perfect addition to the comprehensive range of products from SICK. The services range from product-independent consulting to traditional product services.



- 
**Consulting and design**  
 Safe and professional
- 
**Product and system support**  
 Reliable, fast and on-site
- 
**Verification and optimization**  
 Safe and regularly inspected
- 
**Upgrade and retrofits**  
 Easy, safe and economical
- 
**Training and education**  
 Practical, focused and professional

## SICK AT A GLANCE

SICK is a leading manufacturer of intelligent sensors and sensor solutions for industrial applications. With almost 7,000 employees and over 50 subsidiaries and equity investments as well as numerous representative offices worldwide, we are always close to our customers. A unique range of products and services creates the perfect basis for controlling processes securely and efficiently, protecting individuals from accidents and preventing damage to the environment.

We have extensive experience in various industries and understand their processes and requirements. With intelligent sensors, we can deliver exactly what our customers need. In application centers in Europe, Asia and North America, system solutions are tested and optimized in accordance with customer specifications. All this makes us a reliable supplier and development partner.

Comprehensive services round out our offering: SICK LifeTime Services provide support throughout the machine life cycle and ensure safety and productivity.

**For us, that is “Sensor Intelligence.”**

### **Worldwide presence:**

Australia, Austria, Belgium, Brazil, Canada, Chile, China, Czech Republic, Denmark, Finland, France, Germany, Great Britain, Hungary, India, Israel, Italy, Japan, Malaysia, Mexico, Netherlands, New Zealand, Norway, Poland, Romania, Russia, Singapore, Slovakia, Slovenia, South Africa, South Korea, Spain, Sweden, Switzerland, Taiwan, Thailand, Turkey, United Arab Emirates, USA, Vietnam.

Detailed addresses and additional representatives → [www.sick.com](http://www.sick.com)