

USER INSTRUCTIONS

en

All rights reserved. Subject to change without notice.

Instrument Air Adapter for in-situ gas analyzers



1 About this document

This document describes the installation, commissioning and maintenance of the instrument air adapter. This document is only valid for the accessory described in the Product Identification. This document is intended for persons who commission, operate and maintain the device.

2 Basic safety information

- This document is only valid in combination with the Operating Instructions of the corresponding analyzer. Read and observe the safety instructions and warnings contained therein.
- Do not put the device into operation until this document and the Operating Instructions have been read and understood. Contact SICK Customer Service if you have any questions.
- The standards and directives of the Declaration of Conformity used are specified with the respective device.
- Keep this document together with the Operating Instructions for reference and pass it on to a new owner.

Correct use

- Use the device only as described in "Intended use". The manufacturer assumes no responsibility for any other use.
- Carry out the specified maintenance work.
- Do not carry out any work or repairs on the device that are not described in this Manual. Do not remove, add or modify any components to or on the device unless described and specified in the official manufacturer information.
- Use only original spare parts and wear and tear parts from SICK.
- The device is suitable for use in potentially explosive atmospheres. This is determined by the respective analyzer used and must be adhered to.

If not observed:

- The manufacturer's warranty becomes void.
- The device could become dangerous.
- The approval for use in potentially explosive atmospheres is no longer valid.

Special local conditions

In addition to the information in this Manual, follow all local laws, technical rules and company-internal Operating and Installation Instructions applicable wherever the device is installed.

2.1 Notes on measuring operation of the gas analyzer

NOTE

- For reliable operation, the gas analyzer must be permanently supplied with instrument air.
ATTENTION: If the instrument air fails, the analyzer must be taken out of operation immediately.
- When commissioning and recommissioning the analyzer, for example after servicing, an instrument air supply in accordance with the applicable standard with $p=0.1 \dots 10$ bar and a media temperature of max. 50 °C must be available.
- Before switching on the analyzer, the instrument air supply must be available for at least one minute with a flow rate of min. 100 l/min.
- No adjustment or maintenance work may be carried out while the analyzer is in measuring mode.
- Maintenance including a flow test must be carried out once a year.

2.2 Work on the device

Risk of explosion

Risk of explosion when working on the device.

- ▶ Ensure no explosive atmosphere is present when working on the device.
- ▶ The compressed air must not contain explosive atmosphere.

Incorrectly connected potential equalization can lead to potential differences which can create sparks due to transient phenomena (discharges) and lead to explosions in Ex atmospheres.

- ▶ Include all metal parts in the equipotential bonding of the plant.
- ▶ Carry out regular checks that grounding connections are intact.

Escaping exhaust air and leakage can stir up deposited dust and cause an explosive dust atmosphere.

- ▶ The analyzers used with the instrument air adapter do not have a corresponding dust Ex qualification.
- ▶ Ensure clean ambient conditions.
- ▶ Check for leaks regularly.

In the event of leaks, an explosive atmosphere may be present in the instrument air adapter.

- ▶ Check for leaks regularly.

2.3 Intended use

The instrument air adapter is used to set the required air flow for the named analyzers in order to purge their optical surfaces and ensure long-term measurement reliability.

Operation in an Ex environment is possible (see Ex approval of the corresponding analyzer).

2.4 User qualification

The device may only be operated by authorized persons who, based on their training on, and knowledge of the specific device, as well as knowledge of the relevant regulations can assess the tasks given and recognize the hazards involved.

3 Purge gas supply

The sender/receiver unit must be permanently supplied with purge gas during operation in order to keep the optical surfaces clean and to cool the measuring probe (at high gas temperatures). The purge gas (e.g. air, nitrogen) must be available on-site with an overpressure of 1...6 bar (rel.).

3.1 Purge gas requirement

The adapter on the standard device has a G1/2" internal thread, to which the purge gas line is connected using an appropriate adapter. The purge gas line should be made of antistatic material to avoid electronic discharge.

3.2 Compressed air requirement

The following Table can serve the user as a planning and orientation aid for the design of the compressed air network. It shows the required supplied compressed air volume (m³/h) at different pressure ratios to achieve the desired purge gas demand. The values in the Table have been calculated without taking duct pressure and purge gas temperature into account.

The values given are recommendations. Fluctuations may occur depending on the parameters present at the measuring point.

NOTICE:

Failure to comply with the quality requirements for the instrument air can lead to clogging of the lines and contamination of the optical surfaces.

- Use compressed air according to ISO 8573-1:2010 [2:3:2].

	Pressure of the supplied compressed air [bar (rel.)]					
	1 bar _(rel.)	2 bar _(rel.)	3 bar _(rel.)	4 bar _(rel.)	5 bar _(rel.)	6 bar _(rel.)
Purge gas requirement	Required compressed air volume [m³/h]					
l/min	97	168	230	290	360	415
m ³ /h	5.8	10.1	13.8	17.4	21.6	24.9

The pressure range of approx. 3 bar applies to the GMP probe version.

For the cross-duct version with purge air attachments with DN100 flanges, the range of approx. 5 bar per duct side applies.

For the cross-duct version with purge air attachments with DN125 flanges, the range of approx. 6 bar per duct side applies.

3.3 Purge gas quality

In addition to cooling the measuring probe, the supplied purge gas is mainly used to keep the optical surfaces clean. The purge gas should be dry and free of dust and oil. The cleaner the purge gas, the less the optical surfaces become soiled. The maintenance cycle can thus be extended.

4 Mounting

4.1 Retrofitting the instrument air adapter

Procedure:

- Remove the plug in the purge air attachment.
- Fit the instrument air adapter with the three O-rings.
- When connecting the purge gas line to the instrument air adapter, ensure that this connection is sealed.
- Carry out a leak test.
- Carry out a flow test.

4.2 Cross-duct version

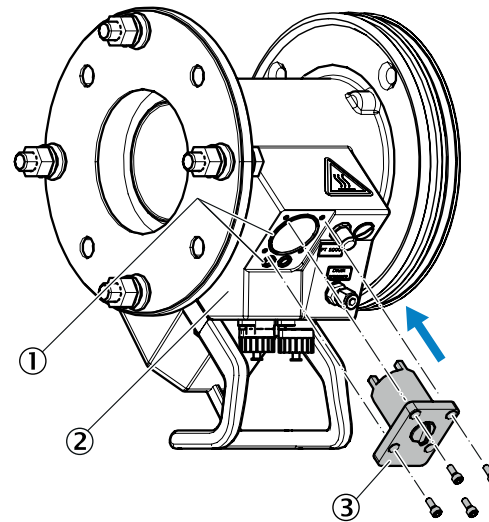

- ① O-rings
- ① Purge air attachment
- ② Instrument air adapter

Fig. 1: Fitting the instrument air adapter (cross-duct version)

4.3 Probe version

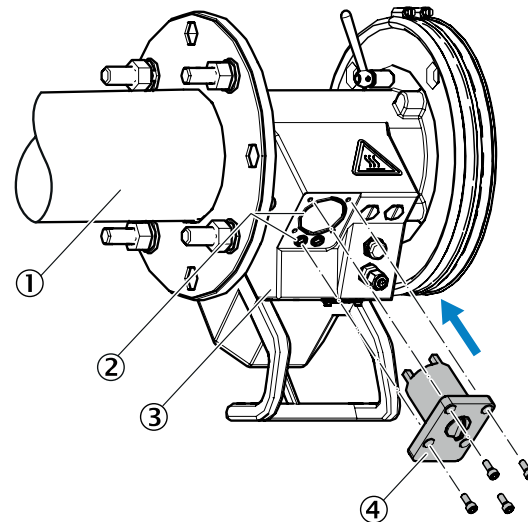

- ① Measuring probe
- ② O-rings
- ③ Purge air attachment
- ④ Instrument air adapter

Fig. 2: Fitting the instrument air adapter (probe version)

5 Maintenance

The following regular checks are necessary:

- Visual inspection (corrosion, damage, etc.)
- Qualitative leak test (e.g. leakage spray)
- Flow test