

MLG-2 ProNet

Measuring automation light grid with CANopen[®]
fieldbus

SICK
Sensor Intelligence.



Described product

MLG-2 ProNet

Manufacturer

SICK AG
Erwin-Sick-Str. 1
79183 Waldkirch
Germany

Legal information

This work is protected by copyright. Any rights derived from the copyright shall be reserved for SICK AG. Reproduction of this document or parts of this document is only permissible within the limits of the legal determination of Copyright Law. Any modification, abridgment or translation of this document is prohibited without the express written permission of SICK AG.

The trademarks stated in this document are the property of their respective owner.

© SICK AG. All rights reserved.

Original document

This document is an original document of SICK AG.



Contents

1	About this document.....	8
1.1	Further information.....	8
1.2	Symbols used.....	8
1.3	Abbreviations used.....	8
2	Safety information.....	10
2.1	Requirements for the qualification of personnel.....	10
2.2	Correct use.....	10
2.3	General safety notes.....	11
3	Product description.....	12
3.1	Type code.....	12
3.1.1	Monitoring height.....	13
3.1.2	Optical properties.....	13
3.1.3	Preconfigurations.....	14
3.2	MLG-2 product properties.....	14
3.3	Setup and function.....	14
3.3.1	MLG-2 ProNet device components.....	14
3.3.2	Measurement principle.....	15
3.3.3	Beam separations and monitoring height.....	16
3.3.4	Sensing ranges.....	17
3.3.5	Synchronizing the MLG-2.....	17
3.3.6	Teach-in.....	17
3.3.7	Beam blanking.....	18
3.4	Scan time.....	18
3.4.1	Response time, minimum presence time and reproducibility of the MLG-2.....	19
3.4.2	Scan time with cross-beam function.....	19
3.4.3	Scan time with high-speed scan on the MLG-2.....	20
3.5	Beam separation and minimum detectable object.....	21
3.5.1	Minimum detectable object with parallel-beam function.....	21
3.5.2	Minimum detectable object length.....	22
3.5.3	Minimum detectable object with cross-beam function	23
3.5.4	Minimum detectable object with high measurement accuracy from the MLG-2.....	24
3.6	Operating reserve.....	25
3.6.1	Operating reserves on the MLG-2.....	25
3.7	MLG-2 operating modes.....	25
3.7.1	Standard operating mode.....	25
3.7.2	Transparent operating mode.....	25
3.7.3	Dust- and sunlight-resistant operating mode.....	26
3.8	Interfaces, functions and process data.....	26
3.8.1	Interfaces.....	27
3.8.2	Configurable functions.....	27

3.8.3	Available process data.....	30
3.9	Display and operating elements.....	32
3.9.1	Sender.....	32
3.9.2	Receiver.....	32
3.9.3	Fieldbus module.....	34
3.10	Application examples.....	34
3.10.1	Application examples for the MLG2.....	34
4	Mounting.....	36
4.1	Scope of delivery.....	36
4.2	Recommended mounting arrangements.....	36
4.2.1	Mounting with light in opposite directions.....	36
4.2.2	Mounting with light in the same direction.....	37
4.2.3	Placement of two light grids at right angles.....	39
4.2.4	Minimum distance from reflective surfaces.....	40
4.3	Mounting procedure.....	41
4.3.1	Mounting the QuickFix bracket.....	41
4.3.2	Mounting the FlexFix bracket.....	43
4.3.3	Turning the fieldbus module on the MLG-2.....	45
4.3.4	Mounting the fieldbus module offset from the MLG-2.....	47
5	Electrical installation.....	48
5.1	Fieldbus module connections.....	48
5.2	Sender connections.....	51
5.3	T-distributor for MLG-2 ProNet connection.....	52
6	Commissioning.....	55
6.1	Mechanical alignment of sender and receiver.....	55
6.2	Alignment and teach-in.....	56
7	The MLG-2 on the CANopen network.....	58
7.1	Overview.....	58
7.1.1	Node ID and baud rate.....	60
7.1.2	Setting of node ID and baud rate.....	60
7.1.3	Configuration using an EDS file.....	62
7.2	Acyclic data (service data).....	62
7.3	Cyclic data (process data).....	63
7.4	Object library.....	64
7.5	1xxxh – Standard objects.....	68
7.5.1	Device type.....	68
7.5.2	Error register.....	68
7.5.3	SYNC message.....	69
7.5.4	Type code.....	69
7.5.5	Hardware version.....	69
7.5.6	Firmware version.....	69
7.5.7	Node guarding.....	70

7.5.8	COB-ID of the emergency message.....	70
7.5.9	Inhibition time for emergency message.....	71
7.5.10	Heartbeat.....	71
7.5.11	MLG-2 identification values.....	72
7.6	Standard object for defining process data.....	72
7.6.1	Communication parameter of the Receive PDOs.....	74
7.6.2	Mapping parameter of the Receive PDOs.....	74
7.6.3	Communication parameter of the Transmit PDOs.....	75
7.6.4	Mapping parameter of the Transmit PDOs.....	76
7.7	2xxxh – Manufacturer-specific objects.....	77
7.7.1	Objects with process data.....	77
7.7.2	Objects for the teach-in function.....	89
7.7.3	Objects for definition of operating mode and performance options.....	93
7.7.4	Objects with auxiliary resources and diagnostic options.....	97
7.7.5	Objects with system information.....	100
7.7.6	Objects with beam evaluation.....	102
7.7.7	Objects for initiating operating functions.....	104
7.7.8	Compatibility objects.....	104
8	Configuration with SOPAS ET.....	108
8.1	Preparation.....	108
8.1.1	Installing the software.....	108
8.1.2	Device selection.....	108
8.2	SOPAS ET interface.....	109
8.2.1	System boundaries and status.....	110
8.2.2	Basic functions and status of the output.....	111
8.2.3	Representation of the detection area.....	112
8.2.4	Expandable menus.....	116
8.3	System settings.....	118
8.3.1	System settings for the user levels EASY and EXPERT.....	118
8.3.2	System settings for the EXPERT user level.....	118
8.3.3	System settings for CANopen.....	120
8.4	Measuring and diagnostic functions for switching outputs.....	120
8.4.1	Height classification.....	121
8.4.2	Object recognition.....	123
8.4.3	Object detection/object width.....	125
8.4.4	Hole detection/hole size.....	127
8.4.5	Outside/inside dimension.....	129
8.4.6	Classification of an object position.....	131
8.4.7	Classification of a hole position.....	132
8.4.8	Diagnostics.....	134
8.4.9	Advanced settings for the outputs.....	134
8.5	Zones.....	135
8.5.1	“Zone measuring” function.....	135
8.6	Teach-in.....	138

8.7	Performance options.....	140
8.7.1	“Cross beam” function.....	143
8.7.2	Energy option (only at the EXPERT user level).....	146
8.8	Beam evaluation.....	146
8.8.1	“Blocked Beams Hold (BBH)” evaluation mode.....	146
8.8.2	“Lost Beams Hold (LBH)” evaluation mode.....	147
8.9	Simulation.....	148
8.10	Beam monitor (only in the EXPERT user level).....	150
8.11	Function programming (in the EXPERT user level).....	151
8.11.1	Beam functions.....	153
9	Configuration of MLG-2 with the internal web server.....	155
10	Servicing.....	156
11	Troubleshooting.....	157
11.1	Response to faults.....	157
11.2	SICK support.....	157
11.3	LED indicators and error indicators	157
11.4	Advanced diagnostics on the MLG-2.....	158
12	Decommissioning.....	159
12.1	Disposal.....	159
12.2	Returns.....	159
13	Technical data.....	160
13.1	Data sheet.....	160
13.2	Data sheet - fieldbus module.....	162
13.3	Diagrams.....	163
13.3.1	Response time and minimum presence time without high-speed scan.....	163
13.3.2	Response time and minimum presence time during high-speed scan with 2,5 mm resolution.....	164
13.3.3	Response time and minimum presence time during high-speed scan with up to 3.5 m sensing range.....	164
13.3.4	Response time and minimum presence time during high-speed scan with up to 8.5 m sensing range.....	165
13.3.5	Minimum detectable absorption.....	165
13.4	Dimensional drawings.....	166
13.4.1	Dimensional drawing MLG-2 ProNet.....	166
13.4.2	Measurement tables.....	167
13.4.3	Dimensional drawings for the MLG-2 fieldbus module.....	169
14	Ordering information.....	171
15	Accessories.....	172
15.1	Auxiliary equipment.....	172
15.2	Mounting materials.....	172

15.3	Connection materials.....	172
16	Annex.....	175
16.1	Conformities and certificates.....	175
16.2	Licenses.....	175
17	List of figures.....	176
18	List of tables.....	179

1 About this document

1.1 Further information

You can find the product page under the **Product ID**: pid.sick.com/{P/N}.

P/N corresponds to the part number of the product.

The following information is available depending on the product:

- Data sheets
- These operating instructions in all available languages
- CAD files and dimensional drawings
- Certificates (e.g., declaration of conformity)
- Other publications
- Software
- Accessories

1.2 Symbols used

Recommendation

Recommendations are designed to assist you in the decision-making process with respect to the use of a certain function or a technical measure.



NOTE

Notes inform you about special aspects of the device.



LED symbols describe the status of a diagnostics LED. Examples:

- | | |
|--|--------------------------------------|
| | The LED is illuminated continuously. |
| | The LED flashes evenly. |
| | The LED flashes briefly. |
| | The LED is off. |

- Take action ...

Instructions for taking action are indicated by an arrow. Carefully read and follow the instructions for action.



CAUTION Warning!

A warning indicates a specific or potential hazard. This is intended to protect you against accidents.

Read carefully and follow the warnings!

Sender and receiver

In figures and connection diagrams, the symbol indicates the sender and indicates the receiver.

1.3 Abbreviations used

BNB	Beam Number Blocked
BNM	Beam Number Made
CBB	Central Beam Blocked
CBM	Central Beam Made
EDS	Electronic Data Sheet
FBB	First Beam Blocked

FBM	First Beam Made
IDI	Inside Dimension
LBB	Last Beam Blocked
LBM	Last Beam Made
MDA	Minimum Detectable Absorption
MDO	Minimum Detectable Object
MLG-2	Measuring automation light grid 2
MOL	Minimum Detectable Object Length
MSB	Most Significant Bit
NBB	Number of Beams Blocked
NBM	Number of Beams Made
NCBB	Number of Consecutive Beams Blocked
NCBM	Number of Consecutive Beams Made
ODI	Outside Dimension
RLC	Run-length code
SDD	SOPAS Device Description
PLC	Programmable logic controller

2 Safety information

2.1 Requirements for the qualification of personnel

The MLG-2 measuring automation light grid must only be mounted, commissioned, and maintained by authorized personnel.



NOTE

Repair work on the MLG-2 may only be performed by qualified and authorized service personnel from SICK AG.

The following qualifications are necessary for the various tasks:

Table 1: Authorized personnel

Task	Qualification
Mounting	<ul style="list-style-type: none"> • Basic practical technical training • Knowledge of the current safety regulations in the work-place
Electrical installation and device replacement	<ul style="list-style-type: none"> • Practical electrical training • Knowledge of current electrical safety regulations • Knowledge of the operation and control of the devices in their particular application (e. g., industrial robots, storage and conveyor systems)
Commissioning, operation, and configuration	<ul style="list-style-type: none"> • Knowledge of the current safety regulations and of the operation and control of the devices in their particular application • Knowledge of automation systems • Knowledge of how to use automation software

2.2 Correct use

The MLG-2 measuring automation light grid is a measuring device which is manufactured according to the recognized industrial regulations and which meets the quality requirements stipulated in ISO 9001:2008 as well as those relating to environmental management systems as defined in ISO 14001:2009.

The measuring automation light grids are solely intended for the optical and non-contact detection of objects, animals, and persons.

A measuring automation light grid is designed for mounting and may only be operated according to its intended function. For this reason, it is not equipped with direct safety devices.

The system designer must provide measures to ensure the safety of persons and systems in accordance with the legal guidelines.

In the event of any other usage or modification to the MLG-2 measuring automation light grid (e.g., due to opening the housing during mounting and electrical installation) or in the event of changes made to the SICK software, any claims against SICK AG under the warranty will be rendered void.

Foreseeable misuse

The MLG-2 is **not** suitable for the following applications, among others:

- As a safety device to protect persons, their hands, or other body parts
- Under water
- In explosive environments
- Outdoors, without additional protection

2.3 General safety notes



CAUTION

Observe the following to ensure the safe use of the MLG-2 as intended.

The measuring automation light grid must be installed and maintained by trained, qualified personnel with knowledge of electronics, precision engineering, and control programming. The relevant technical safety standards must be observed.

All persons entrusted with the installation, operation, or maintenance of the devices must follow the safety guidelines:

- The operating instructions must always be available and must be followed.
 - Unqualified personnel must stay away from the system during installation and maintenance.
 - The system must be installed in accordance with the applicable safety regulations and mounting instructions.
 - The work safety regulations of the employers' liability insurance associations and trade associations in the respective country must be observed during installation.
 - Failure to observe the relevant work safety regulations may lead to physical injury or cause damage to the system.
-

3 Product description

3.1 Type code

Example

MLG-2 with 5 mm beam separation, type ProNet, monitoring height 145 mm, CANopen interface and 1 switching output, no options, 5 m sensing range

Table 2: Example of an MLG-2 ProNet type code

1	2	3	4	5	6	7	8	9	10	11	12	13	14	15	16	17
M	L	G	0	5	N	-	0	1	4	5	C	1	0	5	0	1

Table 3: Meaning of the positions in the type code

Position	Meaning	
1 ... 3	Product family	MLG
4 and 5	Beam separation	02 = 2.5 mm 05 = 5 mm 10 = 10 mm 20 = 20 mm 25 = 25 mm 30 = 30 mm 50 = 50 mm
6	Type	0 = Special type N = ProNet
7	Hyphen	-
8 ... 11	Detection height	0000 = Special detection height see table 4, page 13
12	Interfaces, I/O	C = CANopen + 1 switching output
13	Options	1 = none
14 and 15	Optical properties	see table 5, page 13
16 and 17	Preconfiguration of the I/O connections and the software	see table 6, page 14

3.1.1 Monitoring height

Table 4: Monitoring height [mm]

	Type						
	MLG02...	MLG05...	MLG10...	MLG20...	MLG25...	MLG30...	MLG50...
Monitoring height [mm]	145	145	140	140	-	-	-
	295	295	290	280	275	270	250
	445	445	440	440	425	420	400
	595	595	590	580	575	570	550
	745	745	740	740	725	720	700
	895	895	890	880	875	870	850
	1045	1045	1040	1040	1025	1020	1000
	1195	1195	1190	1180	1175	1170	1150
	-	1345	1340	1340	1325	1320	1300
	-	1495	1490	1480	1475	1470	1450
	-	1645	1640	1640	1625	1620	1600
	-	1795	1790	1780	1775	1770	1750
	-	1945	1940	1940	1925	1920	1900
	-	2095	2090	2080	2075	2070	2050
	-	2245	2240	2240	2225	2220	2200
	-	2395	2390	2380	2375	2370	2350
	-	2545	2540	2540	2525	2520	2500
	-	-	2690	2680	2675	2670	2650
	-	-	2840	2840	2825	2820	2800
-	-	2990	2980	2975	2970	2950	
-	-	3140	3140	3125	3120	3100	

3.1.2 Optical properties

Table 5: Sensing range and minimum detectable object length

Position 14 and 15	Sensing range	Minimum detectable object length
00	Special	Special
32	2 m	2.5 mm
05	5 m	5 mm
08	8.5 m	5 mm

3.1.3 Preconfigurations

Table 6: Preconfiguration of MLG-2 ProNet with fieldbus version C

Position 16, 17	Output	Address	Data transmission rate
01	System status Status of the switching output NBB LBB FBB ODI IDI	6 LSS	125 kBit/s

3.2 MLG-2 product properties

- Different beam separations from 2.5 mm to 50 mm
- Monitoring heights from 130 to 3,140 mm
- Operating range up to 2 m, 5 m or 8.5 m
- Quick response time
- Convenient configuration using the SOPAS ET software interface
- Detection of transparent objects
- Dust- and sunlight-resistant
- Integrated applications including object detection, height classification, etc.

3.3 Setup and function

The MLG-2 is an optical light grid. It comprises a sender and a receiver.

The sender consists of sender optics, several sender elements (LEDs), and actuation electronics. The receiver consists of receiver optics, several receiver elements (photodiodes) and evaluation electronics.

3.3.1 MLG-2 ProNet device components

The MLG-2 ProNet consists of:

- Sender = MLG-2 Pro
- Receiver = MLG-2 ProNet
- Fieldbus module



Figure 1: MLG-2 ProNet device components

- ① MLG-2 Pro sender
- ② MLG-2 ProNet receiver
- ③ Fieldbus module

The sender has a connection for the power supply and the synchronization.

The receiver has a connection for the fieldbus module.

The fieldbus module has a fieldbus interface, an Ethernet connection for configuring via PC/notebook, a connection for the power supply, and a connection for the receiver.

3.3.2 Measurement principle

Provided no object is located between the sender and receiver elements, the light beams from the sender elements will hit the receiver elements.

If an object is located between the sender and receiver elements, the light beams will be blocked, depending on the size of the object.

Detection area

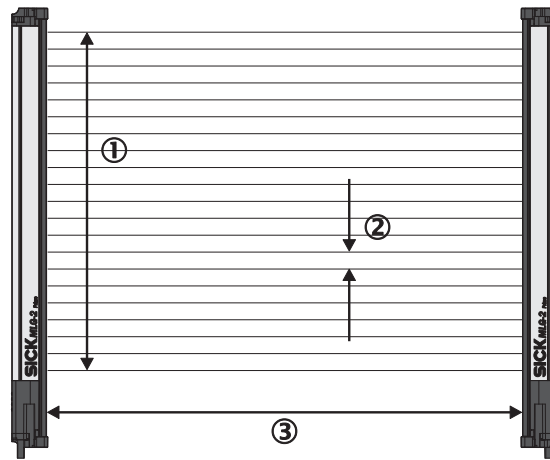

Figure 2: Detection area of the MLG-2

- ① Monitoring height
- ② Beam separation
- ③ Sensing range

The detection area is determined by the monitoring height and the sensing range of the light grid. The monitoring height is determined by the beam separation and the number of beams. The sensing range of the light grid is the distance between sender and receiver.

3.3.3 Beam separations and monitoring height

Beam separations

In order to achieve different levels of measurement accuracy, the MLG-2 is available with different beam separations.

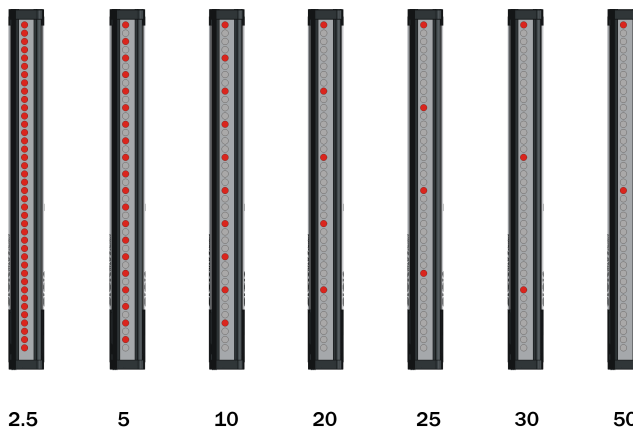

Figure 3: Schematic depiction of available beam separations (mm)

Maximum and minimum monitoring height

The number of LEDs is limited to 510. This results in different maximum monitoring heights depending on the beam separation. The minimum monitoring height is determined by the beam separation and the smallest module size for this beam separation.

Table 7: Maximum monitoring heights

Beam separation	Maximum monitoring height	Minimum monitoring height
2.5 mm	1195 mm	145 mm
5 mm	2,545 mm	145 mm
10 mm	3,140 mm	140 mm
20 mm	3,130 mm	130 mm
25 mm	3,125 mm	275 mm
30 mm	3,1320 mm	270 mm
50 mm	3,100 mm	250 mm

3.3.4 Sensing ranges

Operating range

Light grids are generally available with a 2 m range, 5 m range or 8.5 m sensing range. This is referred to as the operating range, which includes an operating reserve.

Limiting range

It is also possible to operate the MLG-2 up to its limiting range, which goes beyond the operating range.

Table 8: Limiting range

Operating range	Limiting range
2 m	2.8 m
5 m	7 m
8.5 m	12 m

Operation within the limiting range requires the following conditions:

- Clean ambient conditions
- Front screens are cleaned regularly
- Regular teach-in

The following functions cannot be provided when operating within the limiting range:

- High level of operating reserves
- High measurement accuracy
- Transparent operating mode
- Dust- and sunlight-resistant operating mode

3.3.5 Synchronizing the MLG-2

The sender and receiver synchronize with each other electronically, thus **one** electrical connection between the sender and receiver is necessary.

3.3.6 Teach-in

During the teach-in process, the switching thresholds for all beams are individually adjusted for the sensing range and the ambient conditions.

After teach-in has been completed, it must be ensured that the setup is no longer changed otherwise another teach-in will have to be carried out.

Teach-in quality

The teach-in quality indicates how successful the teach-in process has been. The MLG-2 calculates this value based on the quality of the light level received.

The value remains constant until another teach-in process is carried out.

Process quality

The process quality indicates the quality of the light level currently being received. The MLG-2 analyzes the light level received when the light path is unblocked and compares this to the values after the last teach-in process.

If the received values are getting worse, the process quality drops.

Possible causes of a drop in process quality include:

- Contamination or fogging of the front screen of the sender and/or receiver
- Misalignment
- Continuous partial blocking of a light beam or several light beams

3.3.7 Beam blanking

Individual beams can be blanked.

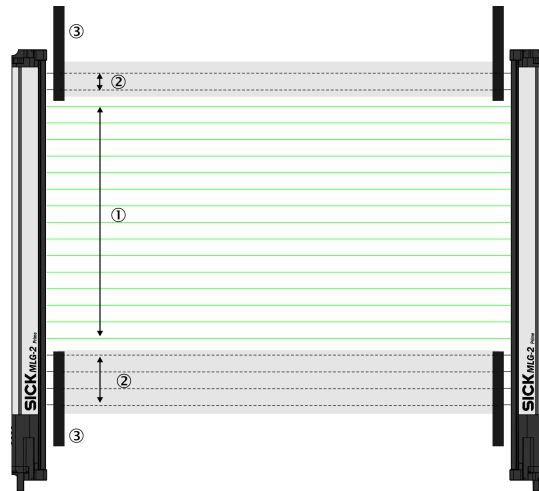

Figure 4: Detection area with beams blanked

- ① Included beams
- ② Blanked beams
- ③ Structural restrictions on the detection area

The MLG-2 offers a variety of options for masking beams.

3.4 Scan time

In the MLG-2, not all light beams are active at the same time, instead one light beam is activated after the other starting from the bottom.



Figure 5: Standard scan method

The scan time increases according to the number of beams of an MLG-2.

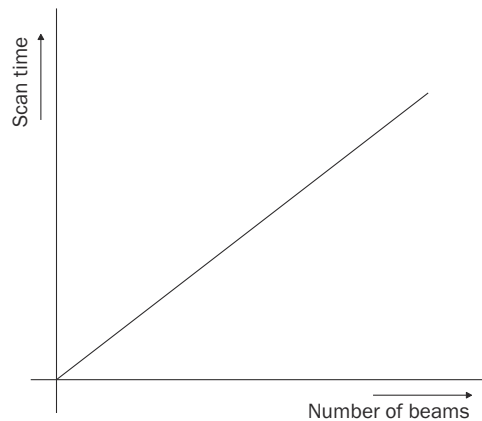

Figure 6: Scan time in relation to the number of beams

The scan time is used to determine the **response times** of the outputs, the **minimum presence time** of an object and the **repeat accuracy of a measurement result (reproducibility)**.

- The **response time** is the time it takes for an output to react following the detection of an object/gap. The maximum response time is $3 \times$ the scan time plus the transmission time to the outputs.
- The **minimum presence time** is the time an object or a gap has to be in the detection area for it to be detected. The minimum presence time is $\max. 2 \times$ the scan time.
- The repeat accuracy of a measurement result (**reproducibility**) is the amount of time by which an object detection can differ from a previous or subsequent detection. The reproducibility time is $1 \times$ the scan time.

3.4.1 Response time, minimum presence time and reproducibility of the MLG-2

On the MLG-2, the response time, minimum presence time, and reproducibility are displayed via SOPAS ET. Response time and minimum dwell time can be read off in the diagram see [figure 143, page 163](#).

3.4.2 Scan time with cross-beam function

When the cross-beam function is enabled, the light beam from a sender LED is received by three receiver diodes in two scans. This doubles the scan time.

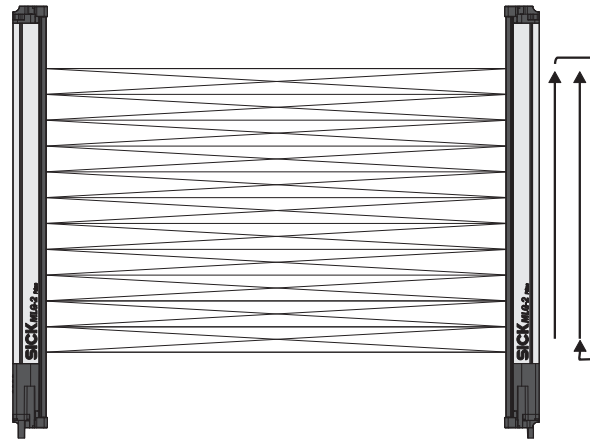

Figure 7: Cross-beam function

3.4.3 Scan time with high-speed scan on the MLG-2

With high-speed scan, several beams are active in each cycle. This reduces the scan time by a variable factor.

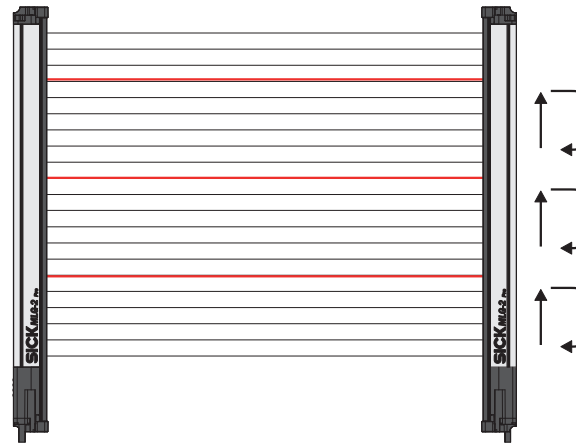

Figure 8: High-speed scan

The scan time is also dependent on the number of beams. Beyond a certain number of beams, the scan time is reduced because it is possible to use the high-speed scan.

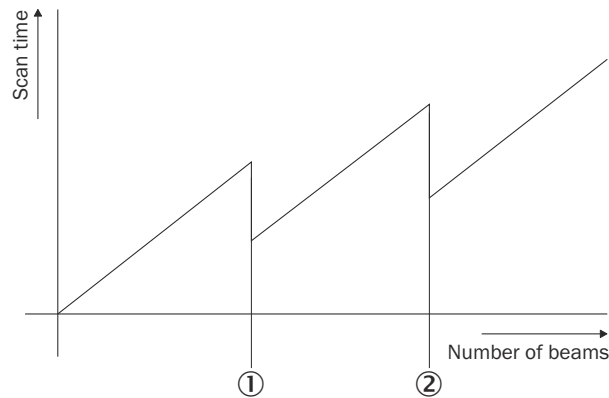

Figure 9: Scan time in relation to the number of beams when using the high-speed scan

- ① High-speed scan with 2 beams active simultaneously

② High-speed scan with 3 beams active simultaneously

The number of beams that can be activated at the same time depends on the size of the detection area (sensing range, beam separation, and number of beams). On the MLG-2, the response time, minimum presence time, and reproducibility are displayed via SOPAS ET. You can also find the response time and minimum presence time when using the high-speed scan in the diagrams in these operating instructions (see "Diagrams", page 163).



NOTE

With a beam separation of 2.5 mm, the high-speed scan can only be adjusted in combination with the high measurement accuracy function.

3.5 Beam separation and minimum detectable object

The measurement accuracy achieved by the MLG-2 depends on the beam separation.

3.5.1 Minimum detectable object with parallel-beam function

In order for an object to be detected continuously, it must completely cover at least one beam. This is referred to as the minimum detectable object, or MDO.

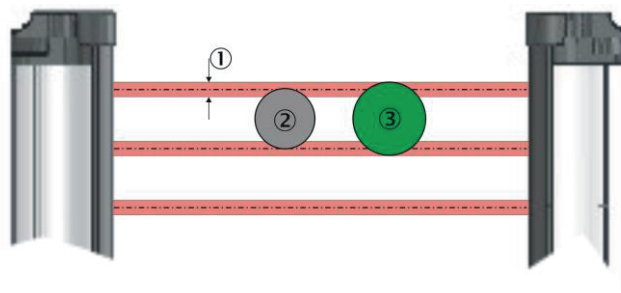

Figure 10: Minimum detectable object

- ① Beam diameter
- ② Object is not completely reliably detected
- ③ Object is reliably detected (meets requirements of minimum detectable object size)



NOTE

For moving objects, the minimum detectable object depends on the speed of the object.

Table 9: Minimum detectable object in relation to the beam separation of the MLG-2

Beam separation	Minimum detectable object (stationary object) ¹²
2.5 mm	3.5 mm
5 mm	9 mm
10 mm	14 mm
20 mm	24 mm
25 mm	29 mm
30 mm	34 mm

Beam separation	Minimum detectable object (stationary object) ¹²
50 mm	54 mm

¹ Only if the object also meets the minimum detectable object length requirements.

² All the values are typical values and can be found in the respective setting modes.



NOTE

The minimum detectable object size is also dependent on the other performance options, such as the configured response time and operating reserve. The precise minimum detectable object size is displayed in SOPAS ET on the MLG-2 (see "SOPAS ET interface", page 109).

3.5.2 Minimum detectable object length

When an object moves through the detection area, it must have a certain length.

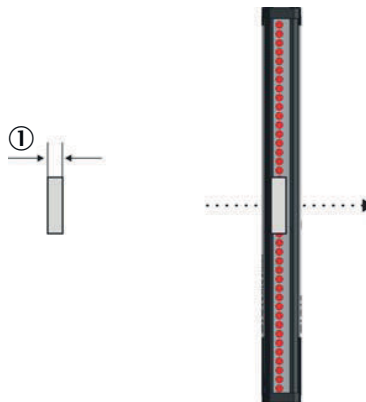

Figure 11: Minimum detectable object length

① Minimum detectable object



NOTE

For moving objects, the minimum detectable object length also depends on the speed of the object.

Table 10: Minimum detectable object length with the MLG-2

Beam separation	Minimum detectable object length (stationary object) ¹
2.5 mm	2.5 mm
5 ... 50 mm	5 mm

¹ Only if the object also meets the minimum detectable object requirements.



NOTE

The minimum detectable object length is also dependent on the other performance options, such as the configured response time and operating reserve. The precise minimum detectable object length is displayed in SOPAS ET on the MLG-2 (see "SOPAS ET interface", page 109).

3.5.3 Minimum detectable object with cross-beam function

The parallel-beam function is used for measuring by default. With the parallel-beam function, each light beam is received only by the receiver element situated directly opposite.

With the cross-beam function, a sender LED projects beams to several receiver diodes. The cross-beam function increases the measurement accuracy and enables the detection of smaller objects.

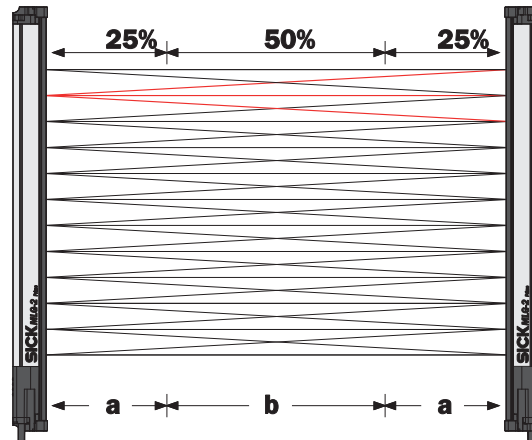

Figure 12: Cross-beam function

A minimum distance between the sender and the receiver is required for the cross-beam function. The minimum detectable object size depends on the position of the object within the detection area. Detection of the smaller minimum detectable object size is therefore only possible in the central area (b) of the detection area.

- The cross-beam function is only useful for object detection ($NBB \leq 1$). For other applications (height classification, object recognition, etc.), the results of the parallel-beam function are used.
- Use of the cross-beam function increases the response time.
- With the cross-beam function, a minimum distance needs to be maintained between sender and receiver. The minimum distance depends on the aperture angle of the light grid.
- For moving objects for the cross-beam function, the minimum detectable object depends on the speed of the object.

Table 11: Minimum detectable object with cross-beam function on the MLG-2

Beam separation	Minimum distance 2 m variant	Minimum distance 5 m variant	Minimum distance 8.5 m variant	Minimum detectable object (stationary object)	
				In area B	In area A
2.5 mm	200 mm	-	-	2.5 mm	4 mm
5 mm	-	110 mm	120 mm	6.5 mm	9 mm
10 mm	-	220 mm	240 mm	9 mm	14 mm
20 mm	-	440 mm	480 mm	14 mm	24 mm
25 mm	-	550 mm	600 mm	16.5 mm	29 mm
30 mm	-	660 mm	720 mm	19 mm	34 mm
50 mm	-	1110 mm	1200 mm	29 mm	54 mm

- High-speed scan is not possible.
- The minimum detectable object size with cross-beam function is also dependent on the other performance options, such as the configured response time and operating reserve. The precise minimum detectable object size is displayed in SOPAS ET on the MLG-2 (see "SOPAS ET interface", page 109).

3.5.4 Minimum detectable object with high measurement accuracy from the MLG-2

On the MLG-2, the measurement accuracy can be increased in SOPAS ET (see "Performance options", page 140). This means that an object can be detected even if it only covers half of a beam.

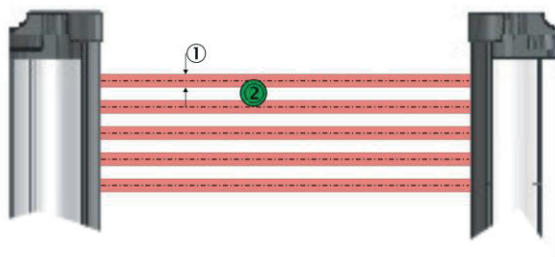

Figure 13: Minimum detectable object size with high measurement accuracy

- ① Beam diameter
- ② Object is reliably detected (meets requirements of minimum detectable object size)

Table 12: Minimum detectable object size with high measurement accuracy

Beam separation	Minimum detectable object (stationary object) ¹
2.5 mm	2.5 mm
5 mm	5 mm
10 mm	10 mm
20 mm	20 mm
25 mm	25 mm
30 mm	30 mm
50 mm	50 mm

¹ Only if the object also meets the minimum detectable length requirements (see table 10, page 22).

Minimum detectable object length

Table 13: Minimum detectable object length with high measurement accuracy

Beam separation	Minimum detectable object length (stationary object) ¹
2.5 mm	1 mm
5 ... 50 mm	2 mm

¹ Only if the object also meets the minimum detectable length requirements (see table 9, page 21).

- When using high measurement accuracy to detect moving objects, the minimum detectable object length also depends on the speed of the object and the other performance options, such as the configured response time and operating reserve. The precise minimum detectable object length is displayed in SOPAS ET on the MLG-2 (see "SOPAS ET interface", page 109).
- Sensing ranges larger than the operating range are not possible when using high measurement accuracy.
- High measurement accuracy can cause the operating reserve to decrease in the event of large sensing ranges and imperfect alignment.

3.6 Operating reserve

The operating reserve defines the operational safety before contamination, vibrations, misalignment, temperature fluctuations, etc. cause the MLG-2 to produce incorrect measurements.

The MLG-2 is subject to a certain level of contamination depending on its environment and application. In principle, the MLG-2 must be cleaned regularly and a teach-in should be carried out after cleaning.

3.6.1 Operating reserves on the MLG-2

On the MLG-2, the operating reserve can be adjusted according to the operating mode.

Standard operating reserve

The standard setting for the operating reserve is the best setting for most applications.

High level of operating reserves

Setting the operating reserve high makes the MLG-2 very resistant to contamination. However, it is not possible to activate high measurement accuracy in this case.



NOTE

In order to achieve a high operating reserve, the input sensitivity must be increased. This increases the risk of reflection. If there are reflective surfaces near the detection area, the light beams from the LEDs may reflect off these surfaces and reach the receiver, even though there is an object in the detection area.

The high input sensitivity means that only opaque objects can be detected. Transparent or semi-transparent objects are not detected.

Low operating reserve

Setting the measurement accuracy high reduces the operating reserve. When the operating reserve is low, the MLG-2 must be cleaned more frequently and a teach-in process must be carried out.

3.7 MLG-2 operating modes

The MLG-2 has the operating modes **Standard**, **Transparent** and **Dust and Sunlight-Resistant**.

Within the operating modes, the performance options can be used to modify the response time, minimum detectable object size, minimum detectable absorption (in Transparent operating mode), and operating reserve.

- The configurable performance options depend on the operating mode selected.
- When the operating mode is changed, a new teach-in process must be performed.

3.7.1 Standard operating mode

Standard operating mode is the mode in which most measuring applications can be carried out.

- Only opaque objects can be detected.
- There must not be a high level of constant light irradiation.

3.7.2 Transparent operating mode

Transparent operating mode enables the detection of transparent objects, such as those made of glass, PET, etc.

Transparent objects do not completely cover the light beam. In order to detect these objects, they must have what is known as a minimum detectable absorption (MDA).



NOTE

It is not possible to use the cross-beam function, high operating reserve or high-speed scan in the Transparent operating mode.

Minimum detectable absorption

In order to detect a transparent object, it must absorb a certain percentage of the energy from the light beam. Depending on the objects being measured, an object can be detected with 30% absorption, 15% absorption, or 10% absorption.



NOTE

The minimum detectable absorption that an object needs in order to be detected increases with the sensing range (see "[Minimum detectable absorption](#)", page 165).

Examples of the signal attenuation of transparent objects¹⁾:

- Approx. 10% signal attenuation:
Clean PET bottles, clear glass, thin and clear films (e.g., cellophane), household plastic film, plastic wrapping
- Approx. 15% signal attenuation:
Clean clear glass bottles, thick films, film and wrapping folded multiple times
- Approx. 30% signal attenuation:
Green and brown glass, colored glass bottles

The following prerequisites must be met:

- The sender and receiver must be aligned precisely with one another.
- The sender and receiver elements must be kept clean at all times.

AutoAdapt

The AutoAdapt function is active in the Transparent operating mode. AutoAdapt adjusts the switching threshold at which objects are detected in accordance with the level of contamination on the MLG-2. As a result, the MLG-2 thus becomes less sensitive as the level of contamination increases.

3.7.3 Dust- and sunlight-resistant operating mode

Dust and sunlight-resistant operating mode is intended for applications when there is a large amount of dust in the environment or a high level of solar radiation.

- Dust and sunlight-resistant operating mode reduces the maximum sensing range
 - To 1.2 m for devices with a 2 m operating range
 - To 3 m for devices with a 5 m operating range
 - To 5 m for devices with an 8.5 m operating range
- This operating mode can only be configured on an MLG-2 with fewer than 240 beams.

3.8 Interfaces, functions and process data

The MLG-2 has a number of different interfaces that can be used to output a measurement result or configure the MLG-2.

¹⁾ Examples are for illustrative purposes only. The signal attenuation and the minimum detectable absorption to be configured must be determined for each individual application.

3.8.1 Interfaces

- An interface for integration into a CANopen fieldbus (see "The MLG-2 on the CANopen network", page 58)
- One Ethernet interface for configuration with SOPAS ET (see "Configuration with SOPAS ET", page 108) or with the integrated web server (see "Configuration of MLG-2 with the internal web server", page 155).
- One switching output (push-pull)
The functions of this switching output can be configured in SOPAS ET (see "Measuring and diagnostic functions for switching outputs", page 120). These functions can also be configured using CANopen (see "The MLG-2 on the CANopen network", page 58).

3.8.2 Configurable functions

The MLG-2's functions can be configured using SOPAS ET, the integrated web server, or via the respective fieldbus. The tables below show which application is used to configure each function.

Table 14: Functions available for or during teach-in

Name	Function	Available for		
		SOPAS ET	Web server	Fieldbus
Teach-in	Starts a teach-in	■	■	■
Teach-in result	Result of the teach-in	■	■	■
Teach-in required	Teach-in required for further operation	■	-	■
Teach-in with blanking	Activate beam blanking for each teach-in	■	-	■
Auto teach-in	Starts a teach-in every time when switching on	■	-	-
Blanks blocked beams	Excludes all blanking beams during the teach-in	■	■	■
Blanks beams made	Excludes all beams made during the teach-in	■	■	■
Beam mask	Any defined beams will be excluded from the measurement. In SOPAS ET by clicking the mouse In the fieldbus via a bit-coded beam mask	■	-	■



NOTE

The information in the MLG-1 operating instructions (8014134) available at www.sick.com applies for the FBM-P22 fieldbus module.

Table 15: Functions available for operating modes and performance options

Name	Description	Available for		
		SOPAS ET	Web server	Fieldbus
Operating mode	Selection of the operating mode	■	■	■
Performance options	Defines the performance options	■	■	■

Name	Description	Available for		
		SOPAS ET	Web server	Fieldbus
Minimum detectable absorption	Sets the minimum detectable absorption for Transparent operating mode	■	■	■
Energy saving mode	Puts the MLG-2 on standby	■	-	■
Scanning method	Defines the parallel beam function, cross beam function or high-speed scan.	■ ¹⁾	-	■ ¹⁾
Configuration Q1	Function programming for switching output Q1	■	■	■
Alarm Q1	Defines various diagnostic settings for Q1	■	-	-
I/O configuration	Defines the function of Q1	■	-	-
Switch-off delay Q1, Q2, Q3 or Q4	Delays the corresponding output	■	-	■
Switch-off delay Q5 through Q16	Delays outputs Q5 through Q16	■	-	■

¹⁾ Available via the performance options.

Table 16: Configurable measuring and diagnostic functions for switching output Q1

Name	Available for		
	SOPAS ET	Web server	Fieldbus
Function programming for switching output Q1	■	■	■
Alarm Q1 Defines various diagnostic settings for Q1	■	-	-
I/O configuration Defines the function of Q1	■	-	-
Height classification	■	-	■
Object recognition	■	-	■
Object detection/object width	■	-	■
Hole detection/hole size	■	-	■
Outside/inside dimension	■	-	■
Classification of the object position	■	-	■
Classification of the hole position	■	-	■
Height classification within a zone	■	-	■
Object detection/object width within a zone	■	-	■
Classification of the object position within a zone	■	-	■
Measuring within zones	■	-	■
Diagnostics (display of warnings/errors)	■	-	■

Table 17: Auxiliary resources and diagnostic options

Name	Description	Available for		
		SOPAS ET	Web server	Fieldbus
Alignment aid	Activates the alignment aid	■	■	■
Values for alignment aid	Returns the values from three beams	■	-	■
“Find Me” function	Activates the “Find Me” function	■	-	■
Pushbutton lock	Activates/deactivates the pushbutton lock	■	-	■
Beam numbering	Reverses the beam numbering	■	-	■
Factory settings	Resets the MLG-2 to its factory settings	■	■	■
Cloning upload	The device parameter set is saved to the fieldbus module.	■	■	■
Cloning download	The device parameter set is loaded from the fieldbus module.	■	■	■
Cloning status	The cloning status shows the status of the stored parameters in the fieldbus module.	■	■	■

Table 18: System information

Name	Description	Available for		
		SOPAS ET	Web server	Fieldbus
Device name	“MLG-2 ProNet” device name	■	■	■
Manufacturer name	“SICK AG” manufacturer name	■	■	■
Part number	Part number for the MLG-2 ProNet	■	-	■
Serial number	MLG-2 ProNet serial number	■	■	■
Product text	Description of MLG-2 ProNet	■	■	■
Mounting location	Option to enter the mounting location	■	■	■
Device characteristics	Display of the device characteristics and system boundaries	■	■	■
Hardware revision	Status of the hardware	■	■	■
Firmware version	The version of firmware	■	■	■

Table 19: Beam evaluation

Name	Description	Available for		
		SOPAS ET	Web server	Fieldbus
Zone measuring	Combines beams into zones and assigns them to a beam function and an output	■	-	■
Cross beam measuring	Activates the “Cross beam measuring” function	■	-	■
Blocked Beams Hold	Evaluation mode for all selected beam functions	■	-	■

Name	Description	Available for		
		SOPAS ET	Web server	Fieldbus
Lost Beams Hold	Evaluation mode for all process data	■	-	■

Table 20: Settings for the interfaces

Name	Description	Available for		
		SOPAS ET	Web server	Fieldbus
IP address	Defines the IP address for the configuration interface	■	-	-
MAC address	Displays the MAC address for the configuration interface	■	-	-
Subnet mask	Defines the subnet mask for the configuration interface	■	-	-
Gateway address	Defines the gateway address for the configuration interface	■	-	-
DHCP	Activates DHCP for the configuration interface	■	-	-

Table 21: Settings for SOPAS ET

Name	Description	Available for		
		SOPAS ET	Web server	Fieldbus
Rotate the MLG-2 display	Rotates the display of the MLG-2 on the SOPAS interface	■	-	-
User level	Sets the user level in SOPAS ET	■	-	-

3.8.3 Available process data

The MLG-2 provides a series of process data. The following table shows which process data is available for the individual applications.

Table 22: Available process data

Name	Function	Available for		
		SOPAS ET	Web server	Fieldbus
NBB	Number of beams blocked Total number of beams blocked (e.g., for object detection)	■	■	■
NBM	Number of beams made Total number of beams made (e.g., for hole detection)	■	-	■
NCBB	Number of consecutive beams blocked (e.g., for object detection). If there are multiple objects in the detection area, the greatest number of consecutive beams blocked is displayed.	■	-	■
NCBM	Number of consecutive beams made (e.g., for hole detection). If there are multiple gaps in the detection area, the greatest number of consecutive beams made is displayed.	■	-	■

Name	Function	Available for		
		SOPAS ET	Web server	Fieldbus
LBB	Last beam blocked Beam number of the last beam blocked (e.g., for object height measurement)	■	■	■
LBM	Last beam made Beam number of the last beam made	■	-	■
FBB	First beam blocked Beam number of the first beam blocked (e.g., for height classification of a hanging object)	■	■	■
FBM	First beam made Beam number of the first beam made	■	■	■
ODI	Outside dimension Total number of beams between the first and last beams blocked (e.g., for measuring the outside dimension)	■	-	■
IDI	Inside dimension Total number of beams made between the first and last beams blocked (e.g., for measuring the inside dimension)	■	-	■
CBB	Central beam blocked Beam number of the central beam blocked (e.g., for measuring an object position)	■	-	■
CBM	Central beam made Beam number of the central beam made (e.g., for measuring a hole position)	■	-	■
NBB Zone X (X = 1, 2, 3 or 4)	Number of beams blocked in the indicated zone Total number of beams blocked (e.g., for object detection)	■	-	■
NCBB Zone X (X = 1, 2, 3 or 4)	Number of consecutive beams blocked (e.g., for object detection) in the indicated zone. If there are multiple objects in the detection area, the greatest number of consecutive beams blocked is displayed.	■	-	■
FBB Zone X (X = 1, 2, 3 or 4)	First beam blocked in the indicated zone Beam number of the first beam blocked (e.g., for height classification of a hanging object)	■	-	■
LBB Zone X (X = 1, 2, 3 or 4)	Last beam blocked in the indicated zone Beam number of the last beam blocked (e.g., for object height measurement)	■	-	■
CBB Zone X (X = 1, 2, 3 or 4)	Central beam blocked in the indicated zone Beam number of the central beam blocked (e.g., for measuring an object position)	■	-	■
RLC1 ... 16	Run-length code Outputs the value of the relevant change	■	■	■

Name	Function	Available for		
		SOPAS ET	Web server	Fieldbus
Beam status	Beam status Outputs the value of each individual beam	■	–	■
QS	Status of the switching output	■	–	■
SYS	System status Consists of several status messages	■	■	■
QoR	Process quality Shows the quality of the light level currently being received	■	■	■
QoT	Teach-in quality Shows the quality after the teach-in	■	–	■
Control	Used for control	–	–	■

3.9 Display and operating elements

3.9.1 Sender

The sender has three LEDs on its front. The LEDs are located on the connection side. The section [LED indicators and error indicators](#) on [page 157](#) explains the meaning of the LED indicators.

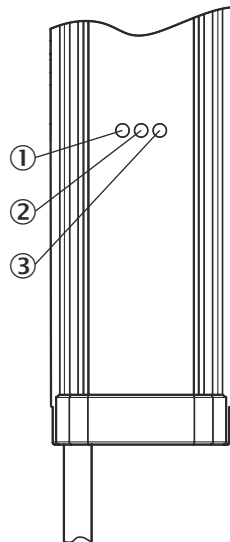

Figure 14: LEDs on the sender

- ① Yellow
- ② Red
- ③ Green

3.9.2 Receiver

The receiver has three LEDs on the front and a control panel with LED and membrane keys on the rear. The LEDs and the control panel are located on the connection side.

The section [LED indicators and error indicators](#) on [page 157](#) explains the meaning of the LED indicators.

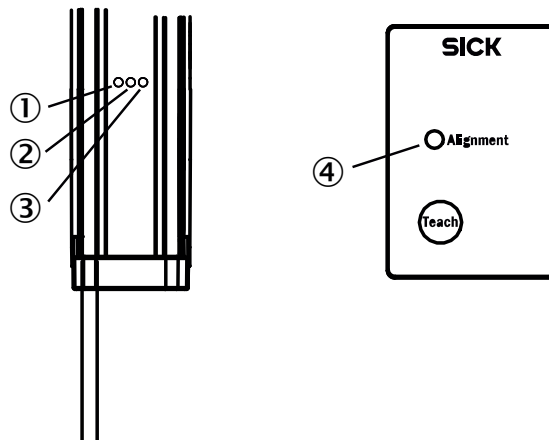

Figure 15: LEDs on the front and on the control panel

- ① Yellow
- ② Red
- ③ Green
- ④ Alignment LED

Control panel

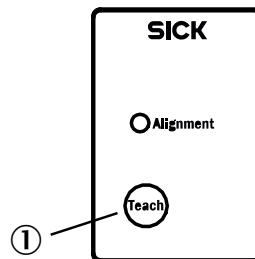

Figure 16: Control panel on the rear side

- ① Teach-in button

The teach-in process for the MLG-2 can be started by pressing the **Teach** pushbutton.

The button can be locked to prevent incorrect operation. The lock can be activated and deactivated via SOPAS ET, the fieldbus function and by pressing the pushbutton.

Locking the control panel

- ▶ Press the **Teach** pushbutton for 15 s.
- ✓ The control panel is locked; the configuration cannot be changed.
- ✓ If a pushbutton is pressed on the control panel, the **Alignment** LED lights up briefly.

Disabling the lock

- ▶ Press the **Teach** pushbutton for 15 s.
- ✓ The lock is disabled again.

3.9.3 Fieldbus module

Status indicators

The fieldbus module has three LEDs.

The section [Troubleshooting](#) on [page 157](#) explains the meaning of the LED indicators.

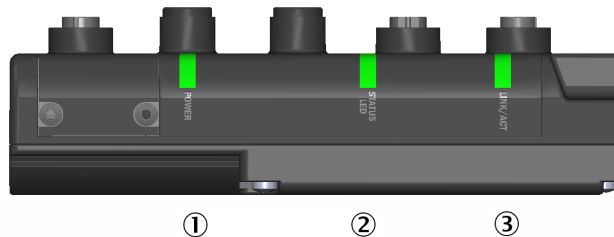

Figure 17: LEDs on the fieldbus module

- ① POWER
- ② STATUS
- ③ LINK/ACT

DIP switches

Eight DIP switches are located under a cover in the fieldbus module. With these switches, you can make settings for the respective fieldbus.

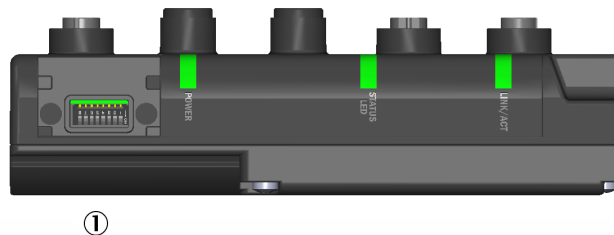

Figure 18: DIP switch on the fieldbus module

- ① DIP switches

3.10 Application examples

3.10.1 Application examples for the MLG2

The MLG-2 is suitable for complex applications including e. g. start and end detection, detection of small or transparent objects, traffic applications, volume measurement, or contour measurement.

Table 23: Application examples for the MLG-2

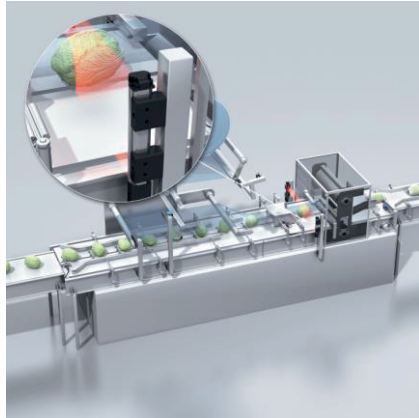

Figure 19: Start and end detection



Figure 20: Detection of transparent objects

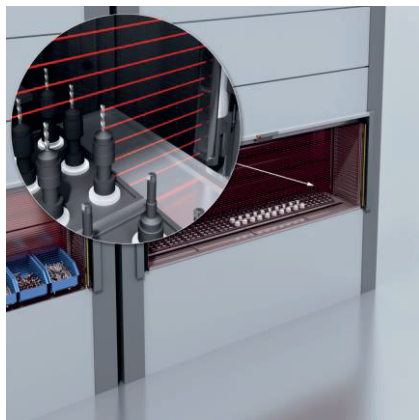

Figure 21: Detection of small objects

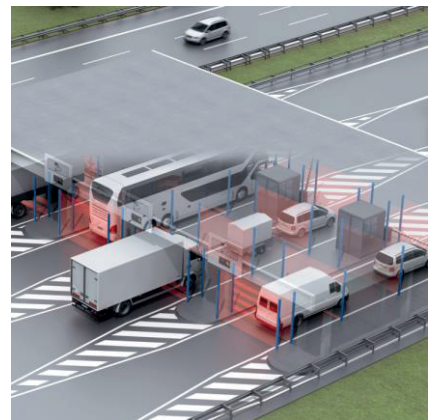

Figure 22: Traffic applications

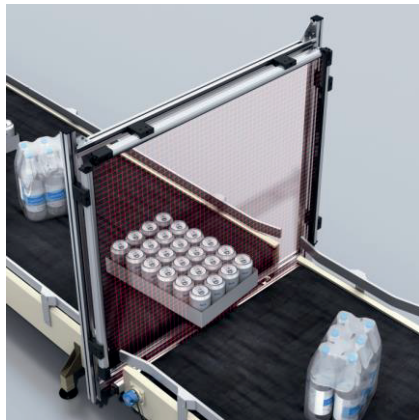

Figure 23: Volume measurement

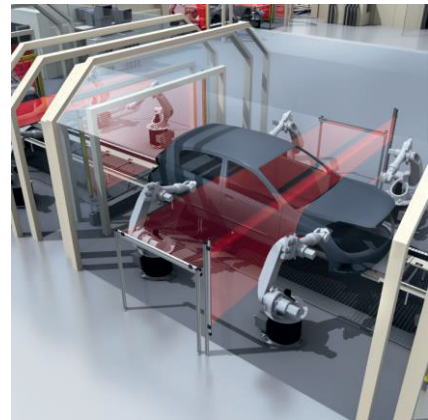

Figure 24: Contour measurement

4 Mounting

4.1 Scope of delivery

- 1 × sender
- 1 × receiver
- 4/6 x QuickFix brackets²⁾
- 1 x mounting bracket for the fieldbus module
- 1 × Quick Start Guide

4.2 Recommended mounting arrangements

When several MLG-2s are mounted close to one another, there is a risk of mutual interference. This is particularly likely if there are shiny surfaces nearby or if the objects being detected are shiny.

Therefore, when mounting two MLG-2s close to one another, their light beams should be oriented in opposite directions.

4.2.1 Mounting with light in opposite directions

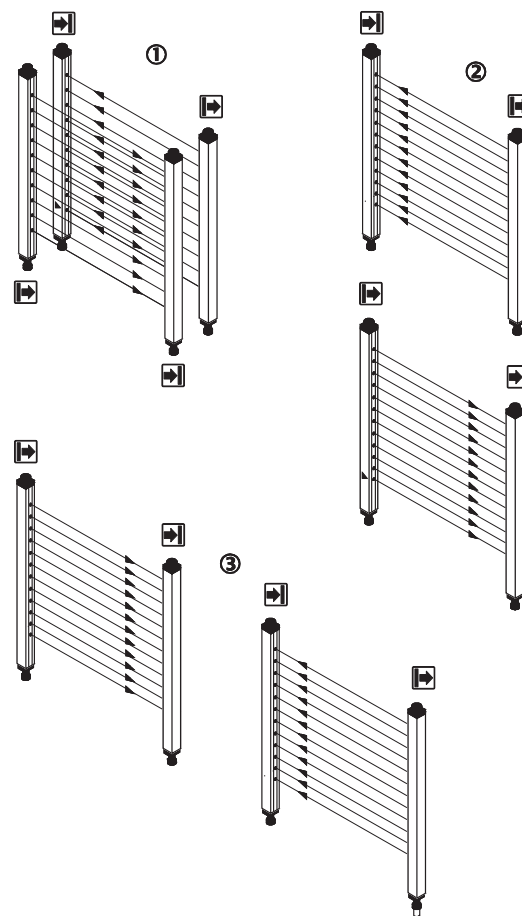

Figure 25: Placement with light in opposite directions

- ① Two MLG-2s, one behind the other
- ② Two MLG-2s, one above the other

²⁾ 6 x FlexFix brackets for monitoring heights above 2 m.

- ③ Two MLG-2s, one next to the other



NOTE

When two MLG-2s are placed opposite one another and their light beams are in opposite directions, ① reflections may occur from sender 1 to receiver 2 in the case of shiny objects.

4.2.2 Mounting with light in the same direction

When several MLG-2s are mounted with their light beams oriented in the same direction, a minimum distance must be maintained between the MLG-2s. The minimum distance increases as the distance between the sender and receiver increases and is dependent on the operating range.

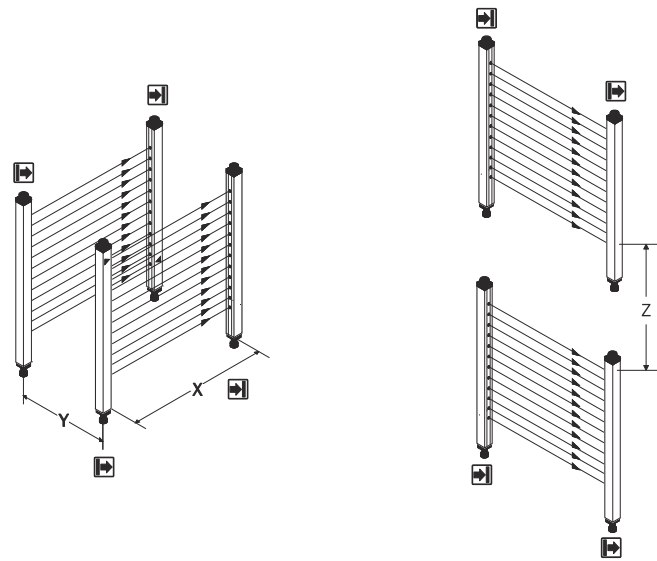

Figure 26: Distances when light is in the same direction

- X Operating range
- Y Minimum distance of the MLG-2
- Z Minimum distance of the MLG-2

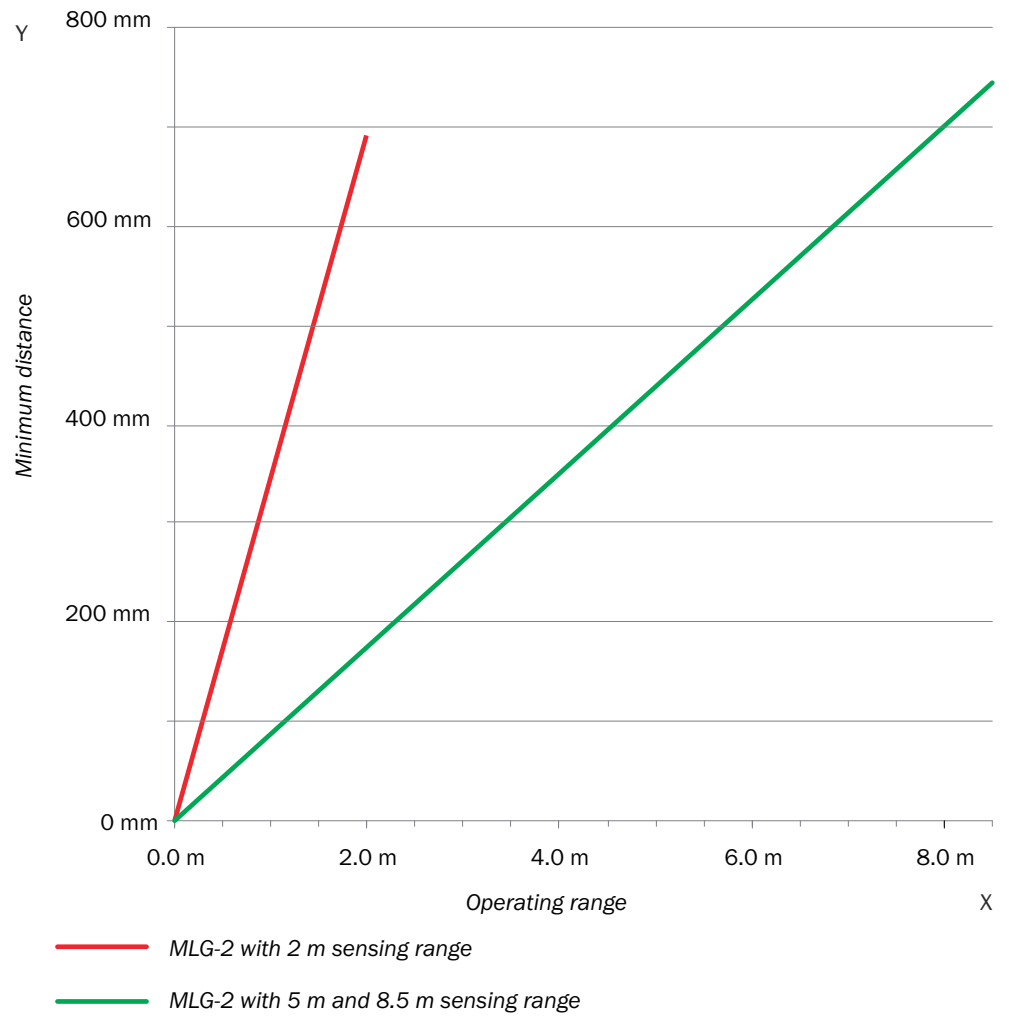

Figure 27: Graph, distances when light is in the same direction

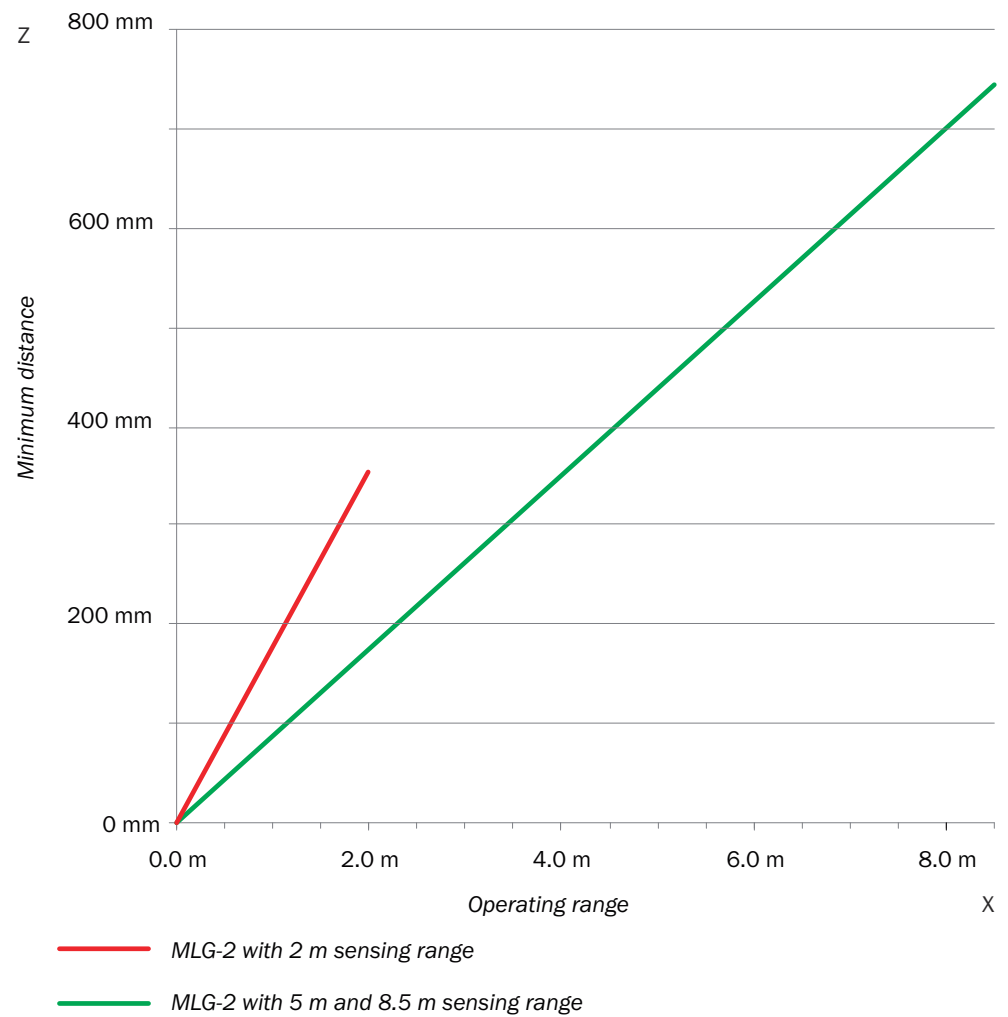

Figure 28: Graph, distances when light is in the same direction (XZ)

4.2.3 Placement of two light grids at right angles

Light grids are placed at right angles for volume detection or operator guidance, for example.

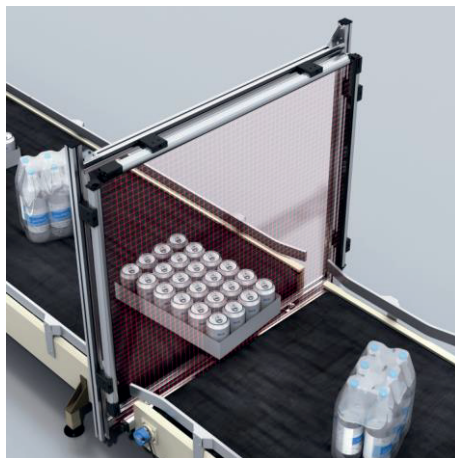

Figure 29: Placement of two light grids at right angles

Test inputs solution

Activate the test inputs of both senders alternately. The beams will be switched off in each case for as long as the test input is active.

Mounting solution

Mount the two MLG-2 as far apart as possible.

4.2.4 Minimum distance from reflective surfaces

Reflective surfaces between the sender and receiver may result in disruptive reflections and beams being deflected and, hence, result in a failure to detect objects.

In the case of reflective surfaces, a minimum distance must be maintained between the reflective surface and the light beams to ensure reliable operation.

This minimum distance depends on the distance between sender and receiver and on the operating range.

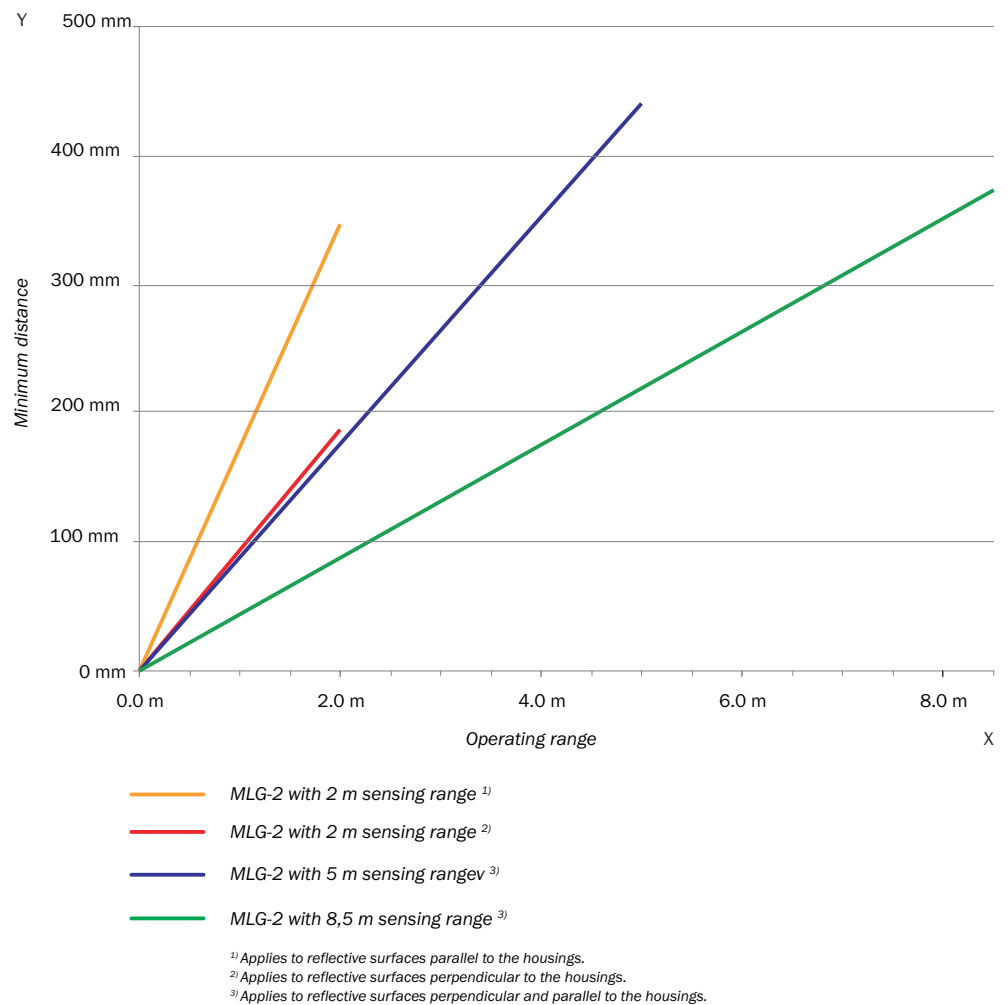

Figure 30: Graph, minimum distance from reflective surfaces

This distance also applies to reflective surfaces located next to the light grid (parallel to the sending/receiving axis).

4.3 Mounting procedure

- ▶ Mount the sender and receiver at the same height. For minor adjustments when aligning, the sender and receiver can be adjusted in the brackets.
- ▶ If possible, mount the top bracket at a height such that the offset in the housing of the MLG-2 sits on the bracket. This prevents the MLG-2 from sliding down.

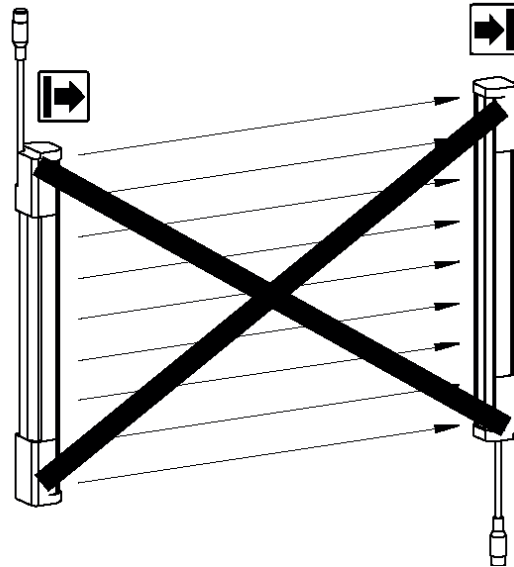

Figure 31: The sender and receiver are aligned incorrectly

The end with the cable connection must point in the same direction for both devices. Sender and receiver must **not be installed at 180° rotated relative to each other**.

Tighten the screws used to mount the bracket to a torque of 5 to 6 Nm. Tighten the screws used to secure the MLG-2 in the bracket to a torque of 2.5 to 3 Nm. Higher torques can damage the bracket while lower torques do not provide adequate fixation to prevent the MLG-2 from moving in the event of vibrations.

When mounting, make sure that sender and receiver are aligned correctly. The optical lens systems of sender and receiver must be located opposite one another. If necessary, use a water level to check the components are parallel.

4.3.1 Mounting the QuickFix bracket

QuickFix brackets can be mounted in two ways:

- On the side
- On the back

The two mounting surfaces for the brackets of the sender or receiver must not be angled more than $\pm 2^\circ$ to each other. If this is not possible, use the optional FlexFix bracket.

Mounting the QuickFix bracket on the side of a machine or profile frame

Up to a monitoring height of 2 m, the sender and receiver are mounted with two QuickFix brackets each.

For a monitoring height of more than 2 m, the sender and receiver are mounted with three QuickFix brackets each.

The QuickFix bracket consists of two parts, which are pushed into each other. An M5 screw is used to join both parts and to clamp the housing (sender or receiver).

Mounting can be carried out in two ways:

- With the M5 screw through the QuickFix bracket to the machine or profile frame. A screw nut or threaded hole is required on the machine or profile frame.
- With the M5 screw through the machine or profile frame to the QuickFix bracket. A screw nut is required for each QuickFix bracket.

When choosing the length of the M5 screw (hexagon head or cylinder head screw), consider the QuickFix bracket and the machine or profile frame.



CAUTION

Risk of injury from protruding screw thread!

When mounting through the machine or profile frame to the QuickFix bracket, the M5 screw can present an injury risk if too long.

- ▶ Select an appropriate screw length to prevent any risk of injury from an overrun.

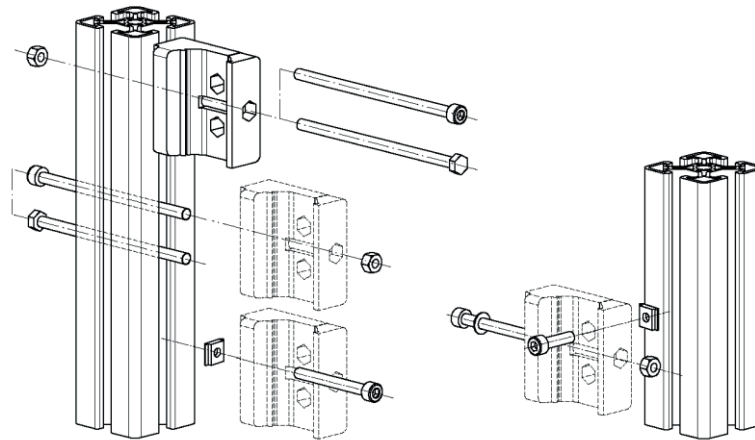

Figure 32: Mount QuickFix bracket to a profile frame

Mount QuickFix bracket to the back of a device column



NOTE

The QuickFix bracket has cable routing. Depending on the installation, the cable routing can make mounting easier.

The sender and receiver are each mounted with two QuickFix brackets.

The QuickFix bracket consists of two parts, which are pushed into each other. An M5 screw is used to join both parts and to clamp the housing (sender or receiver).

You need two M5 screws per bracket if mounting them on the back.

- ▶ Choose the length of the M5 screw such that it is possible to clamp the housing (sender or receiver) in the QuickFix bracket.

QuickFix bracket for the fieldbus module

If you are using the QuickFix bracket, you will need one more QuickFix bracket for the fieldbus module.

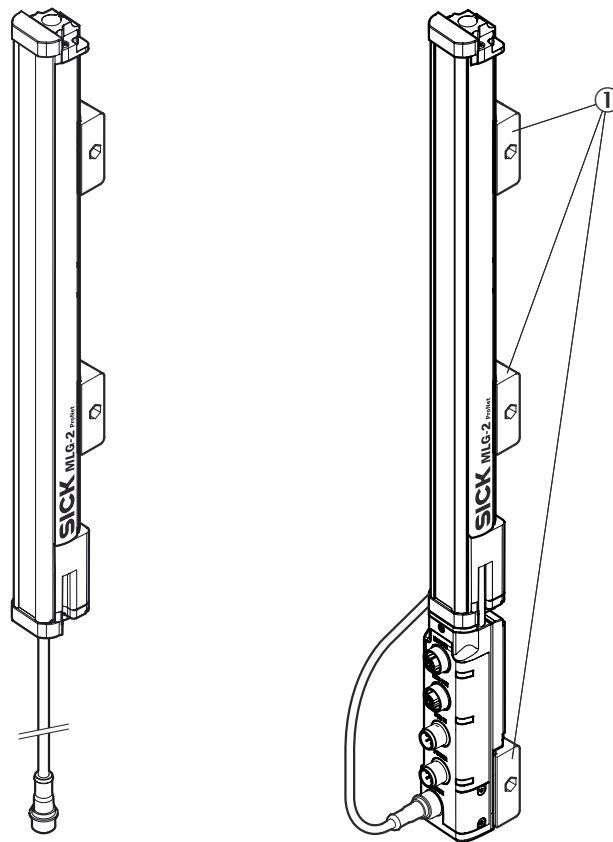

Figure 33: QuickFix bracket for the fieldbus module

① QuickFix brackets

4.3.2 Mounting the FlexFix bracket

In the FlexFix bracket, sender and receiver can be flexibly rotated by $\pm 15^\circ$.

FlexFix brackets can be mounted in two ways:

- On the side
- On the back

Mounting the FlexFix bracket on a profile frame

The sender and receiver are mounted at the designated points using two FlexFix brackets in each case.

M5 screws are inserted through the FlexFix bracket and into the machine or profile frame for mounting. A screw nut or threaded hole is required on the machine or profile frame.

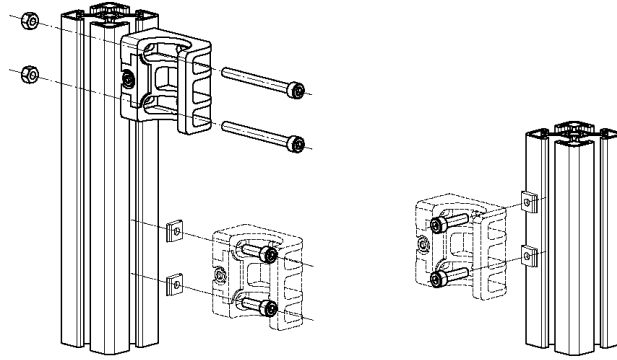

Figure 34: Mounting the FlexFix bracket on a profile frame

Screwing the sender or receiver into the FlexFix brackets

After mounting the FlexFix brackets, screw the sender or receiver into the FlexFix brackets from the front. Then align the sender and receiver.



NOTE

The MLG-2 can only be screwed in when both FlexFix brackets are in alignment. If necessary, use a water level to check the components are parallel.

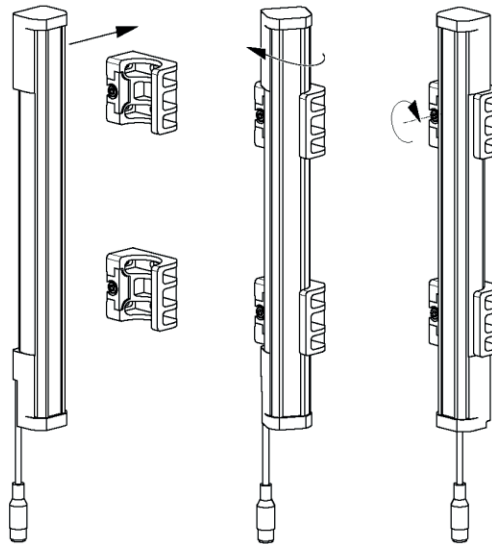

Figure 35: Inserting the MLG-2 in the FlexFix brackets

- ▶ Use an M5 screw to fix the position of the sender and receiver in the FlexFix bracket.

Mounting bracket for the fieldbus module

If you are using the FlexFix bracket, you will need a mounting bracket for the fieldbus module.

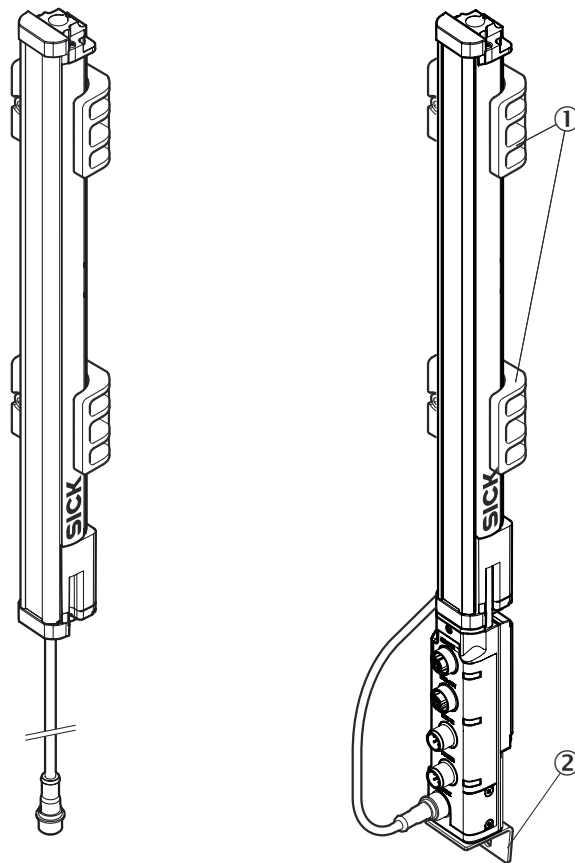

Figure 36: Mounting bracket for the fieldbus module

- ① FlexFix bracket
- ② Mounting bracket

1. Use the M5 x 6 screw provided to fasten the mounting bracket on the fieldbus module.
2. Use an M5 screw with a sliding nut, for example, to mount the mounting bracket on an industrial profile.

4.3.3 Turning the fieldbus module on the MLG-2

All connections of the fieldbus module are provided on one side. You can mount the fieldbus module rotated by 180° so you can feed the cables in from the front or the back.

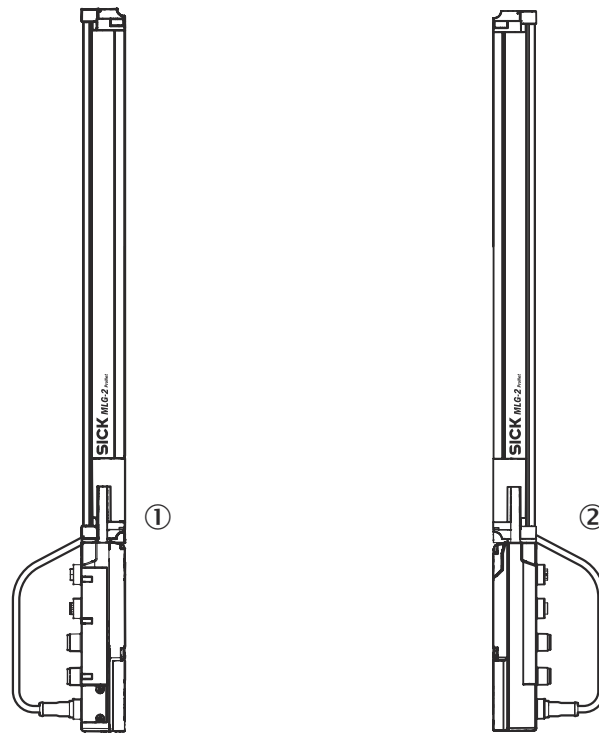

Figure 37: Mounting directions of the fieldbus module

- ① Mounting with the connections to the front side
- ② Mounting with the connections to the rear side

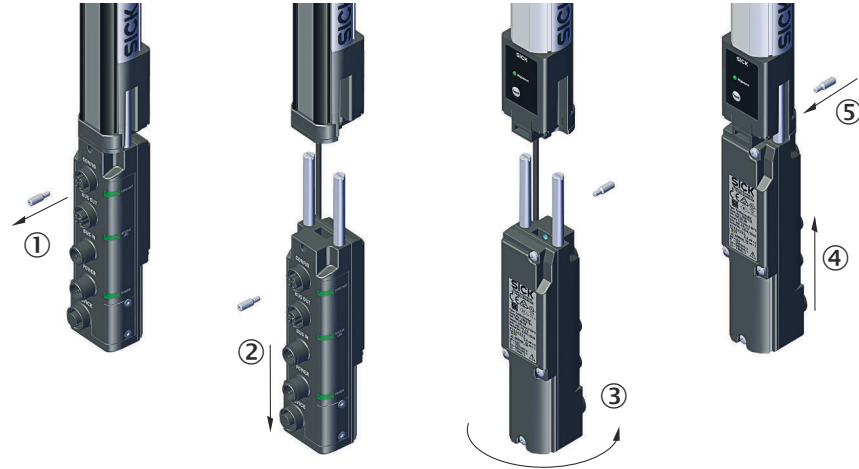

Figure 38: Turn the fieldbus module by 180°

- ① Unscrew the Torx T20 mounting screw
- ② Pull the fieldbus module downwards and away
- ③ Turn the fieldbus module by 180°
- ④ Insert the fieldbus module again
- ⑤ Tighten the mounting screw

4.3.4 Mounting the fieldbus module offset from the MLG-2

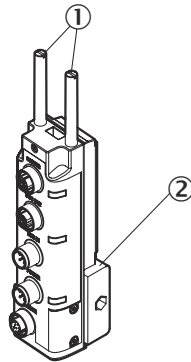

Figure 39: Mount the fieldbus module offset using the QuickFix bracket

- ① Mounting pins
- ② QuickFix bracket

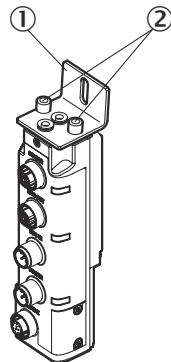

Figure 40: Mount the fieldbus module offset using the mounting bracket

- ① Mounting bracket
- ② M4 × 16

You can mount the fieldbus module offset.

- ▶ Remove the fieldbus module as described (see figure 38, page 46).
 - ▶ Unscrew the mounting pins.
 - ▶ Mount the fieldbus module using a QuickFix bracket.
- Or:
- ▶ Alternatively, mount the fieldbus module using a mounting bracket. Mount the mounting bracket on the fieldbus module using two M4 screws with a maximum length of 16 mm.
 - ▶ Use an M5 screw with a sliding nut, for example, to mount the mounting bracket on an industrial profile.



NOTE

The maximum length of cable between the MLG-2 receiver and the FBM fieldbus module/AFB connection box must not exceed 2.7 m.

5 Electrical installation



CAUTION

De-energize the system!

The system could inadvertently start while you are connecting the devices.

- ▶ Make sure that the entire system is disconnected from the power supply during the electrical installation work.



NOTE

- The MLG-2 complies with the EMC regulations for the industrial sector (Radio Safety Class A). It may cause radio interference if used in a residential area.
- Do not lay cables parallel to other cables, especially not to devices with a high level of radiated emission, such as a frequency converter.
- When using cables over 15 m in length, or in locations with a high level of interference, we recommend using a T-distributor in order to connect the sender and receiver via a short synchronization cable wherever possible.



CAUTION

If you use the connecting cables with AWG 26 for the connection of the MLG-2, secure the MLG-2 with a 1 A / 30 V DC fuse. Use the following table for other wire cross-section fuses.

Table 24: Overcurrent protection

Wire cross-section		Maximum amperage for over-current protection
AWG	mm ²	
20	0.52	5
22	0.32	3
24	0.20	2
26	0.13	1
28	0.08	0.8
30	0.05	0.5

5.1 Fieldbus module connections

All cables for the MLG-2 are connected to the fieldbus module.

Pre-assembled cables are available for the MLG-2 (see ["Accessories"](#), page 172).

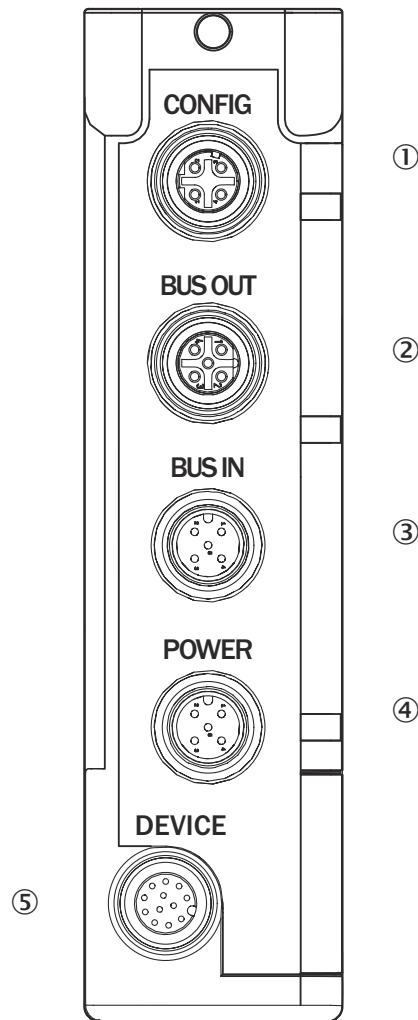

Figure 41: Fieldbus module connections

- ① CONFIG – Ethernet connection for configuring via PC/notebook
- ② BUS OUT - Serial connection of the fieldbus
- ③ BUS IN - Serial connection of the fieldbus
- ④ POWER – Power supply connection
- ⑤ DEVICE – Connection for the MLG-2 ProNet



NOTE

Protect all unused connections with a plastic cap!

CONFIG connection

The CONFIG connection is used to connect a notebook or a PC. You can connect the MLG-2 via this connection using SOPAS ET or using the integrated web server.

Table 25: Pin assignment, CONFIG connection of the fieldbus module

Female connector	Pin	Signal	Meaning
	1	TX+	Ethernet
	2	RX+	Ethernet
	3	TX-	Ethernet
	4	RX-	Ethernet

Connection BUS OUT

Connect the respective fieldbus to the BUS OUT connection.

Table 26: Pin assignment, BUS OUT connection of the fieldbus module

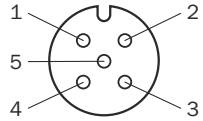
Female connector	Pin	Signal	Meaning
	1	Shield	Shielding
	2	Not connected	Not assigned
	3	GND	Weight
	4	CAN_H	CAN high
	5	CAN_L	CAN low

Connection BUS IN

Connect the respective fieldbus to the BUS IN connection.

Table 27: Pin assignment, BUS IN connection of the fieldbus module

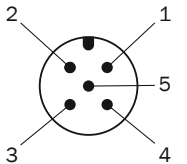
Male connector	Pin	Signal	Description
	1	Shield	Shielding
	2	Not connected	Not assigned
	3	GND	Weight
	4	CAN_H	CAN high
	5	CAN_L	CAN low

POWER connection

Connect the power supply and the sender of the MLG-2 to the POWER connection. If you are using the switching output, then connect this, e.g., to the I/O connection of a programmable logic controller. A T-distributor is available for the connection ([see "T-distributor for MLG-2 ProNet connection", page 52](#)).

Table 28: Pin assignment, POWER connection of the fieldbus module

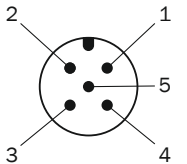
Male connector	Pin	Signal	Meaning	Color
	1	L+	24 V supply voltage	Brown
	2	Sync_A	Synchronization	White
	3	M	GND supply voltage	Blue
	4	Q1	Output signal switching device	Black
	5	Sync_B	Synchronization	Gray

Device connection for the MLG-2 PRONET

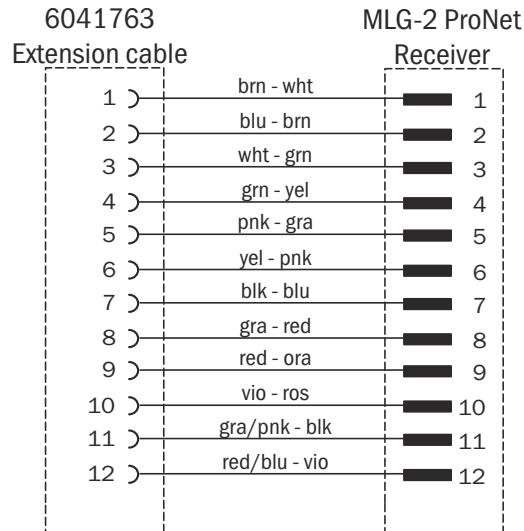

5.2 Sender connections

In the case of the MLG-2, the sender and receiver synchronize with each other electronically. This means that **cabling is required** between the sender and fieldbus module.

You must connect the Sync_A signal on the sender to Sync_A on the fieldbus module, and Sync_B on the sender to Sync_B on the fieldbus module. You will find the Sync_A and Sync_D signals at the POWER connection of the fieldbus module.

Sender connection: M12/5-pin, A-coded

Table 29: Pin assignment, sender connection

Male connector	Pin	Signal	Meaning	Color
	1	L+	24 V supply voltage	Brown
	2	Sync_A	Synchronization	White
	3	M	GND supply voltage	Blue
	4	Test_In	Test input	Black
	5	Sync_B	Synchronization	Gray

5.3 T-distributor for MLG-2 ProNet connection

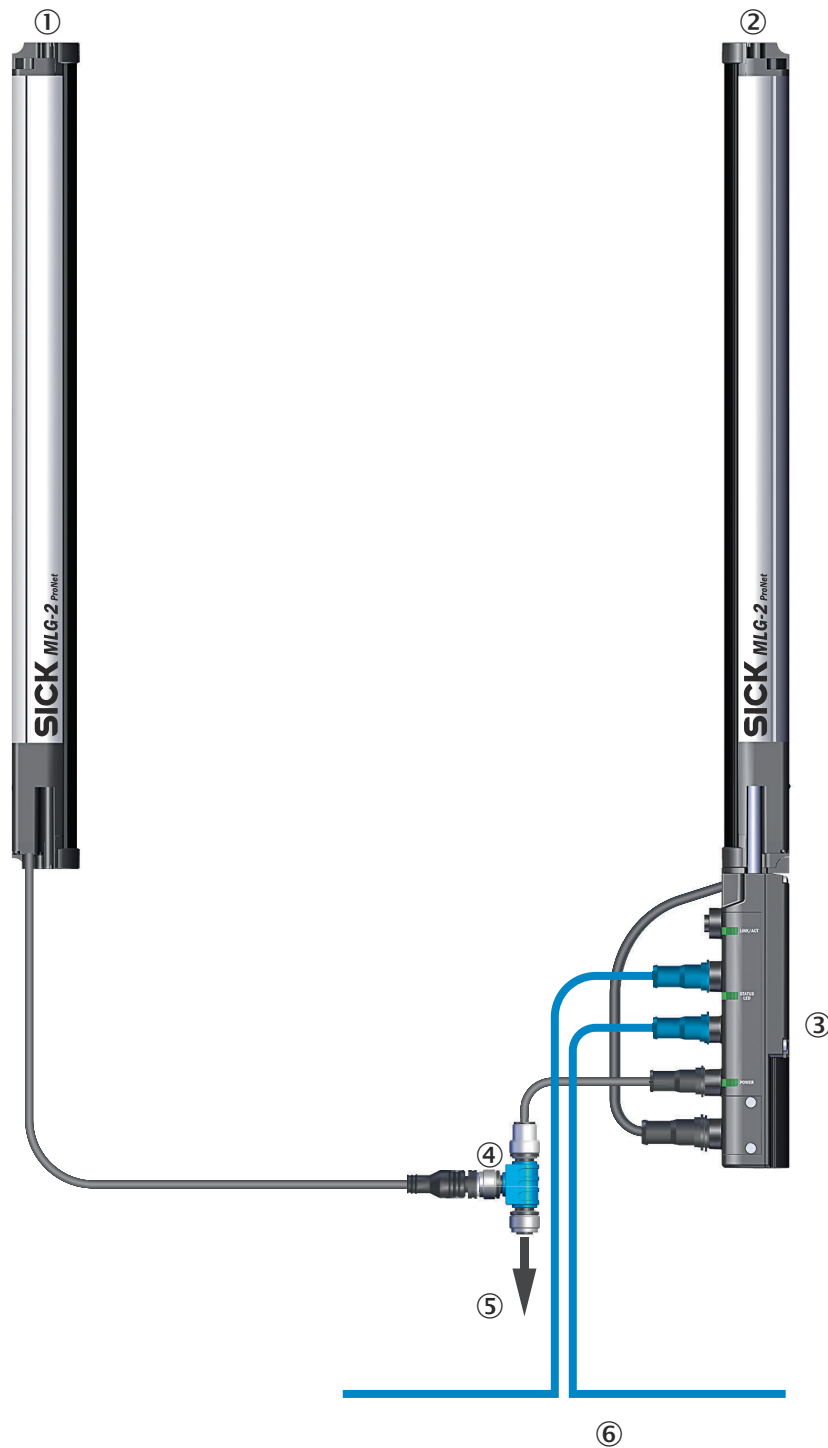

Figure 42: Connection with T-distributor

- ① Sender
- ② Receiver
- ③ Fieldbus module
- ④ T-distributor
- ⑤ Voltage supply
- ⑥ Fieldbus

Connection to the CANopen fieldbus

CANopen is an asynchronous, serial fieldbus. All subscribers are connected in a line as a rule (line topology). The MLG-2 is connected to the fieldbus with a stub cable.

The cables must have the following characteristic values as per ISO 11898-2: ³⁾

- 2-wire, drilled and shielded
- Impedance: 120 Ω
- Specific delay: 5 ns/m
- Resistance per unit length: < 110 Ω /km
- Wire cross-section: 0.25 to 0.8 mm² (depends on baud rate and length of cable)



NOTE

- Do not mix up the two wires A and B in a segment.
- Connect a large area of the shielding to protective ground at both ends of the cable.

We recommend using preassembled connection cables for the wiring (see "Accessories", page 172).

T-distributor for the connection of sender and fieldbus module

A T-distributor is available for the MLG-2 ProNet, which is used to connect the sender and fieldbus module to one another, as well as providing facilities for connecting the power supply, the switching output 1, and the test input.

³⁾ For further details, see ISO 11898-2 and the CANopen specification CiA 303-1.

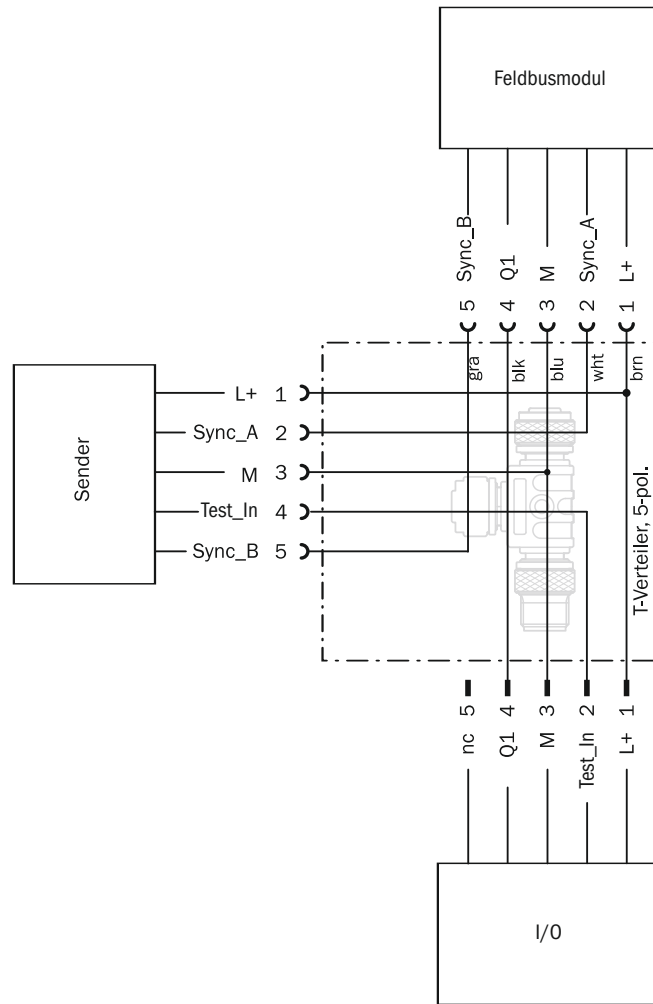

Figure 43: T-distributor of sender and fieldbus module

Table 30: Pin assignment, I/O connection of the T-distributor

Male connector	Pin	Signal	Meaning
	1	L+	24 V supply voltage
	2	Test_In	Test input
	3	M	GND supply voltage
	4	Q1	Switching output 1
	5	Not connected	Not assigned

6 Commissioning

6.1 Mechanical alignment of sender and receiver

After mounting and electrical installation, the sender and receiver must be aligned with each other. No objects should be located between the sender and the receiver. The light path must be clear.

Alignment with the QuickFix bracket

You have the following adjustment options with the QuickFix bracket:

- Adjust vertically (H)

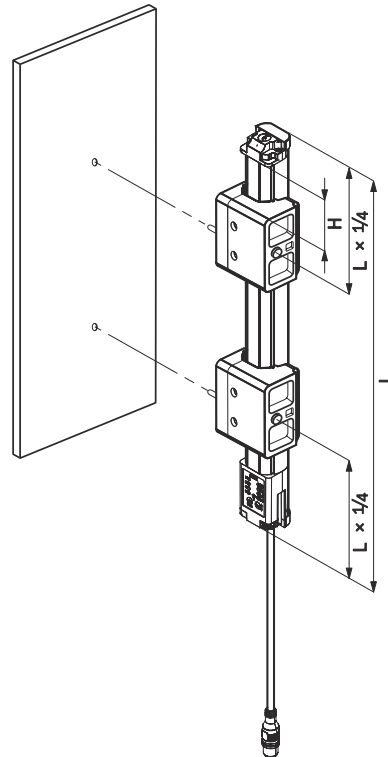

Figure 44: Alignment with the QuickFix bracket

Alignment with the FlexFix bracket

You have the following adjustment options with the FlexFix bracket:

- Adjust vertically (H)
- Rotate ($\pm 15^\circ$)

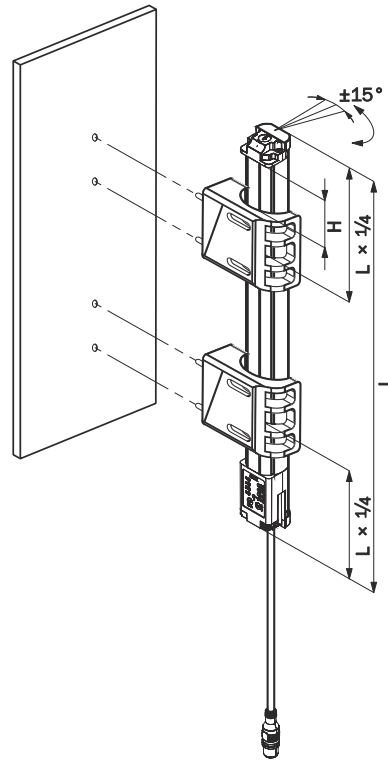

Figure 45: Alignment with the FlexFix bracket

6.2 Alignment and teach-in

To ensure the alignment aid works perfectly, the device should be rotated once from the left bracket stop to the right stop. This makes the best possible settings for the input sensitivity and ensures that the alignment aid shows the most helpful values.

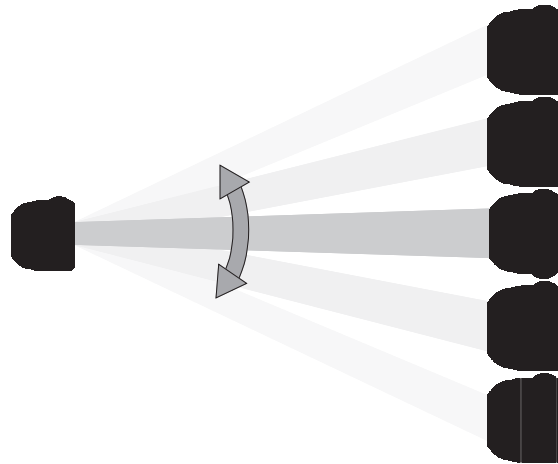

Figure 46: Rotate the receiver once

The yellow LED on the front of the receiver and the **Alignment LED** show the rough alignment.

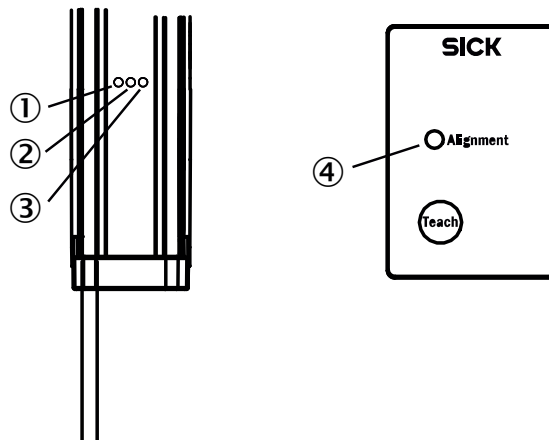

Figure 47: Control panel

- ① Yellow
- ② Red
- ③ Green
- ④ Alignment LED

☀ 3 Hz yellow

The yellow LED on the front and the **Alignment** LED on the control panel flash quickly.

- ▶ Improve the alignment of the MLG-2.
- ✓ When the yellow LED and the **Alignment** LED go out, the MLG-2 is optimally aligned.
- ▶ Now fix the position of the sender and receiver.⁴⁾

Teach-in

- ▶ Press the **Teach** pushbutton (< 1 s).⁵⁾
- ✓ ☀ 1 Hz yellow
- ✓ The yellow LED on the front and the **Alignment** LED flash slowly.

If the teach-in process is successful, the yellow LED on the front and the **Alignment** LED go out. The MLG-2 is operational.

If the teach-in process is unsuccessful, the **Alignment** LED flashes rapidly, as does the red LED on the front of the device.

- ▶ Check that the MLG-2 is correctly aligned, that the front screens are clean, and that there are no objects located in the light path.
- ▶ Then carry out the teach-in process again.

⁴⁾ You can also use the installation wizards in SOPAS ET to perform the alignment work (see "System boundaries and status", page 110).

⁵⁾ The teach-in process can also be initiated via SOPAS ET, the integrated web server, or the PLC.

7 The MLG-2 on the CANopen network

7.1 Overview

Communication profile

The CANopen communication profile (documented in CiA DS-301) regulates how the devices in a CANopen network exchange data.

CANopen in the OSI model

The CANopen protocol is a standardized Layer 7 protocol for the CAN bus. This layer is based on the CAN Application Layer (CAL).

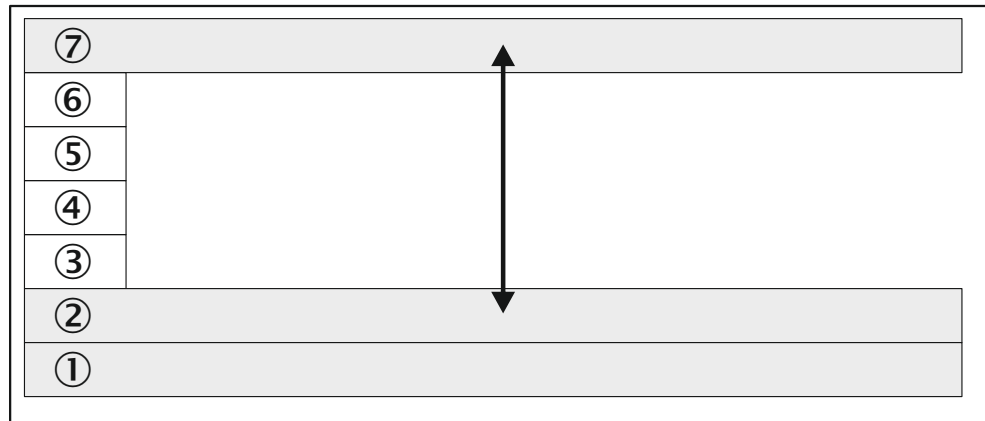

Figure 48: CANopen in the OSI model

- ⑦ CAN application layer
- ② Data link layer
- ① Physical layer



NOTE

Layers 3 to 6 are not used in CANopen.

Architecture

CANopen is an asynchronous, serial fieldbus. All subscribers are connected in a line as a rule (line topology). Stub cables and star-shaped placement are permissible, but this is not always possible.

The fieldbus needs to A passive 120 Ω bus terminating resistor is sufficient for this. The simplest type of bus termination are male cable connectors with terminators (SICK part no. 6021167).

The fieldbus can be expanded with bridges and repeaters.

The optional voltage supply to pin 2 is not supported.

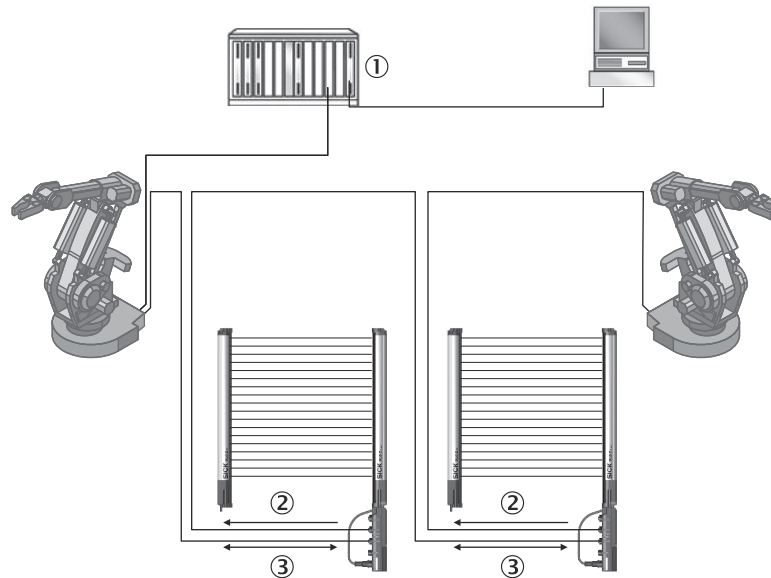

Figure 49: Example of a CANopen network in a line structure

- ① PLC
- ② Cyclic data (process data)
- ③ Acyclic data (service data)

Communication channels and status

CANopen features various communication channels (SDO, PDO, Emergency Messages). These channels are formed with the help of the communication object identifier (COB ID). The COB IDs are based on the node IDs of the individual devices on the CANopen bus.

As soon as the MLG-2 possesses a node ID, it can be addressed via the network management services (NMT) and its CANopen state machine can be switched to the necessary status (Pre-Operational, Operational, or Stopped) by the master.

Network management

Network management (NMT) initializes the nodes in a CANopen network. It also adds the nodes to the network, as well as stopping and monitoring them.

The following statuses can be identified:

Table 31: Status of the CANopen state machine

Status	Description
Initializing	Initialization commences. Both the device application and device communication are initialized. After this, the node automatically switches to Pre-Operational status.
Pre-Operational	The MLG-2 is ready for configuration; acyclic communication can take place via SDO. However, the MLG-2 is not yet able to commence PDO communication and is not sending out any emergency messages.
Operational	In this state, the MLG-2 is fully ready for operation and can transmit messages autonomously (PDOs, emergency messages).
Stopped	In this state, the MLG-2 is not actively communicating (although communication is still being actively monitored via node guarding).

7.1.1 Node ID and baud rate

Node ID

There can be a maximum of 128 devices on a CANopen network: one master and up to 127 slaves. Every device has a unique node ID (node address). The COB IDs (communication object identifiers) of the communication channels are derived from this ID.

A correct node ID must be set for the MLG-2 for communication with the master. The following is correct:

- A node ID which is free in the CANopen network
- A node ID which the master expects

Node ID 6 is set in the MLG-2 at the factory.

Node IDs 1 to 127 can be set (0 is typically allocated to the master).

Baud rate

The same baud rate must be set in the MLG-2 as in the master.

The higher the baud rate used in the CANopen network is, the lower the bus load. The longer the lengths of cable used are, the lower the possible baud rate.

Baud rate 125 kbit/s is set at the factory.

The following baud rates can be assigned to the MLG-2: 10 kbit/s, 20 kbit/s, 50 kbit/s, 125 kbit/s, 250 kbit/s, 500 kbit/s, 800 kbit/s, 1,000 kbit/s.

Maximum length of cable

The max. length of the cable within a segment depends on the baud rate. The table below shows the range per segment without the use of repeaters.

Table 32: Maximum length of cable

Baud rate	125 kbit/s	250 kbit/s	500 kbit/s	1,000 kbit/s
Length of cable	500 m	250 m	100 m	30 m

7.1.2 Setting of node ID and baud rate

Set the node ID and the baud rate as follows:

- Via DIP switch on the fieldbus module
- Via SOPAS ET
- Via layer setting services (LSS)



NOTE

The voltage supply of the MLG must be switched off then back on to activate the baud rate.

A device reset (command 81) is sufficient to activate a changed node ID.

DIP switches

Eight DIP switches are located under a cover in the fieldbus module (see "Fieldbus module", page 34). You can set the node ID and the baud rate of the MLG-2 with these DIP switches.

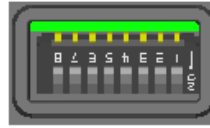

Figure 50: DIP switches 1 to 8 (illustrated as assembled)

The node ID can be set from 1 to 63 with DIP switches 1 to 6. If all six DIP switches are OFF, the node ID set using SOPAS ET or LSS is used.

Table 33: Node ID with DIP switches

DIP switches	6	5	4	3	2	1
Value in ON position	32	16	8	4	2	1
Value in OFF position	0	0	0	0	0	0

1. Set node ID in range 1 to 63 using DIP switches 1 to 6.
 2. Perform a device reset (command 81).
- ✓ The set node ID is now active.

The baud rate can be set with DIP switches 7 and 8. If DIP switches 7 and 8 are OFF, the baud rate set using SOPAS ET or LSS is used.

Table 34: Baud rate with DIP switches

DIP switches	8	7
SOPAS ET or LSS	OFF	OFF
250 kbit/s	ON	OFF
500 kbit/s	OFF	ON
1,000 kbit/s	ON	ON

1. Set the baud rate using DIP switches 7 and 8.
 2. Switch the supply voltage off and then on again.
- ✓ The set baud rate is now active.

SOPAS ET

The node ID and the baud rate of the MLG-2 can also be set via SOPAS ET (see "[System settings for CANopen](#)", page 120).

In the **address configuration** area, you can enter the **address** in CAN and select the **baud rate**. You can enter address 1 to 127 for the MLG-2.

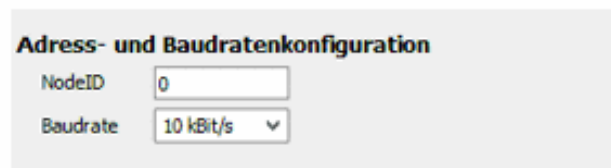

Figure 51: Node ID and baud rate in SOPAS ET

Access via layer setting services

Layer setting services are supported in order to set the node ID and the baud rate of the MLG-2. All DIP switches from 1 to 8 must be OFF to do so.

The LSS slave is accessed via its LSS address (identity object), which is stored in object 1018h. The LSS address comprises:

- Manufacturer ID
- Product code
- Revision number
- Serial number

The master uses the LSS services to request the individual services which are then executed by the MLG-2. The LSS telegrams facilitate communication between LSS master and LSS slave. An LSS telegram is always 8 bytes long. Byte 0 contains the command specifier (CS), followed by 7 bytes for the data. All bytes that are not in use must be set to zero.

The following COB IDs are used:

- 07E4h = LSS slave to LSS master
- 07E5h = LSS master to LSS slave

7.1.3 Configuration using an EDS file

An EDS file is available for easy connection of the MLG-2 to a CANopen master. Among other things, this file contains the default parameters of the MLG-2 and the default configuration for the process data.

You can download the EDS file at www.sick.com:

1. Enter the seven-digit part number of your MLG-2 directly into the **Search** field on the homepage.
2. Click on the relevant search result.
- ✓ This will take you to all the information and files for your device.
3. Download the EDS file.
4. Integrate the EDS file into the engineering tool of your control.

When the MLG-2 is integrated into the CANopen development environment, the object values can be read out and set using the engineering tool.

7.2 Acyclic data (service data)

The service data forms the communication channel through which device parameters (e.g. configuration of the beam numbering) are transmitted. It is used for status queries.

Service data is always transmitted with confirmation, i.e. the receipt of every message is acknowledged by the receiver.

The MLG-2 has a Transmit service data channel and a Receive service data channel, to which two CAN identifiers are assigned.

The service data communication corresponds to the client-server model. The MLG-2 functions as an SDO server. In its request, the SDO client (e.g., the PLC) specifies the parameter, the access method (read/write), and the value, if applicable. The MLG-2 executes read/write access and responds to the request.

The maximum data length of a CAN telegram of 8 bytes is assigned as follows:

Table 35: Service data format

COB-ID	CCD	Index		Subindex	Data			
600h + node ID	Byte 0	Byte 1	Byte 2	Byte 3	Byte 4	Byte 5	Byte 6	Byte 7

The command code (CCD) identifies whether read or write access is required. In the event of an error, the data range will contain a 4-byte error code which provides information about the cause of the error.

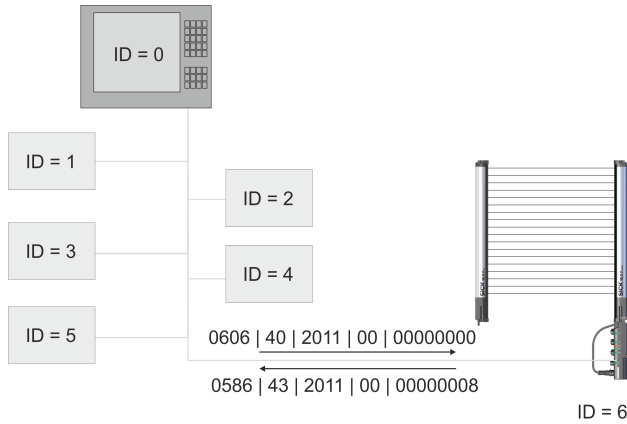

Figure 52: Example of a Receive SDO and a Transmit SDO

In the example, the MLG-2 (ID = 6) receives the read request (CCD = 40h) for object 2211h from the PLC via ID 0606h (Receive SDO 0600h + ID).

The MLG-2 responds by sending ID 0586h (Transmit SDO 0580h + ID) with feedback (CCD = 43h) 00000008h = Teach-in active.



NOTE

All parameters are automatically saved immediately after writing. Only the mapping of the PDOs is not saved and must be reinitialized after every device restart.

7.3 Cyclic data (process data)

Process data is used for rapid and efficient exchange of real-time data (e.g., I/O data, setpoint values or actual values).

8 databytes are available for the transmission of process data. Process data is transmitted without confirmation.

Table 36: Process data format

COB-ID	Data							
0180h + node ID	Byte 0	Byte 1	Byte 2	Byte 3	Byte 4	Byte 5	Byte 6	Byte 7

The MLG-2 supports 10 Transmit PDOs and 2 Receive PDOs.

Data from the MLG-2 is sent to the master with the Transmit PDOs.

The Transmit PDOs are defined by the following objects:

- Objects 1800h to 1809h contain the communication parameters.
- Objects 1A00h to 1A09h contain the object mapping.

The format of the Transmit PDO between the master and the MLG-2 must be agreed through PDO mapping.

Example:

Object 1A00h is set at the factory to contain the following objects:

- 2200.01h – NBB
- 2200.03h – FBB

- 2200.05h – LBB
- 2200.0Bh – ODI

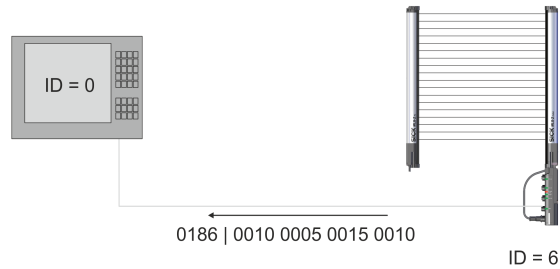

Figure 53: Example for process data

Table 37: Example for process data

COB-ID	Data							
0180h + node ID	00	10	00	05	00	15	00	10
	NBB = 16		FBB = 5		LBB = 21		ODI = 16	

The process data can be arranged at will. The address (i.e. index and subindex) and the size (number of bits) from the entry in the object directory are entered in the mapping object for this purpose.

Bus load

- The more process data and the more frequently it is sent, the higher the bus load in the CANopen network.
- The higher the baud rate used in the CANopen network is, the lower the bus load.
- The longer the lengths of cable used are, the lower the possible baud rate.

A compromise must therefore be found between all three named factors for optimal communication.



NOTE

If a Transmit PDO is not used, it should be deactivated. To do so, set bit 31 to 1 in subindex 01h of the respective object 180xh.

7.4 Object library

Table 38: Access and data type nomenclature

Abbreviation	Meaning
R	Read only access
R/W	Read/write access
STRG	String = a chain of characters of varying length
BOOL	Boolean = logical value 0 or 1
ENUM	Freely selectable values within a limited value range (e.g., BLACK, RED, BLUE, YELLOW)
UINT	Unsigned integer value (e. g., UINT-32 = 0 ... 4,294,967,295)
ARRAY	Sequence of data of the same data type (e.g., array UINT-8 = character string of data type UINT-8)

Abbreviation	Meaning
RECORD	Sequence of data containing different data types (e.g., UINT-8, UINT-32, UINT-32, UINT-16)
STRUCT	Sequence of data containing different data types (e. g., UINT-8, UINT-32, UINT-32, UINT-16)

Table 39: Standard objects

Object	Access	Data type	Name
1000h	R	UINT-32	Device type
1001h	R	UINT-8	Error register
1005h	R/W	UINT-32	COB-ID SYNC message
1008h	R	STRG	Device name
1009h	R	STRG	Hardware version number
100Ah	R	STRG	Software version number
100Ch	R/W	UINT-16	Node guarding – Guard time
100Dh	R/W	UINT-8	Node guarding – Life time factor
1014h	R/W	UINT-32	COB-ID emergency message
1015h	R/W	UINT-16	Emcy inhibition time
1016h	R/W	UINT-32	Consumer heartbeat time
1017h	R/W	UINT-16	Producer heartbeat time
1018h	R	RECORD	Identity object
1400h ... 1401h	R/W	RECORD	Receive PDO – Communication
1600h ... 1601h	R/W	RECORD	Receive PDO– Mapping
1800h ... 1809h	R/W	RECORD	Transmit PDOs – Communication
1A00h ... 1A09h	R	RECORD	Transmit PDOs – Mapping

Table 40: Objects with process data

Object	Access	Data type	Name
2200h, subindex 01h	R	UINT-16	NBB – Number of Beams Blocked
2200h, subindex 02h	R	UINT-16	NBM – Number of Beams Made
2200h, subindex 03h	R	UINT-16	FBB – First Beam Blocked
2200h, subindex 04h	R	UINT-16	FBM – First Beam Made
2200h, subindex 05h	R	UINT-16	LBB – Last Beam Blocked
2200h, subindex 06h	R	UINT-16	LBM – Last Beam Made
2200h, subindex 07h	R	UINT-16	NCBB – Number of Consecutive Beams Blocked
2200h, subindex 08h	R	UINT-16	NCBM – Number of Consecutive Beams Made
2200h, subindex 09h	R	UINT-16	CBB – Central Beam Blocked
2200h, subindex 0Ah	R	UINT-16	CBM – Central Beam Made
2200h, subindex 0Bh	R	UINT-16	ODI – Outside Dimension
2200h, subindex 0Ch	R	UINT-16	IDI – Inside Dimension
2210h	R	UINT-16	Status of the switching output
2211h	R	UINT-16	System status
2212h	R	UINT-16	Process quality
2213h	R	UINT-16	Teach-in quality
2214h	R/W	UINT-8	Control

Object	Access	Data type	Name
2220h, subindex 01h ... 10h	R	UINT-16	Run-length code
2230h, subindex 01h ... 10h	R	UINT-32	Beam status
22C0h, subindex 01h	R	UINT-32	NBB Zone 1 – Number of beams blocked in Zone 1
22C0h, subindex 02h	R	UINT-32	FBB Zone 1 – First beam blocked in Zone 1
22C0h, subindex 03h	R	UINT-32	LBB Zone 1 – Last beam blocked in Zone 1
22C0h, subindex 04h	R	UINT-32	NCBB Zone 1 – Number of consecutive beams blocked in Zone 1
22C0h, subindex 05h	R	UINT-32	CBB Zone 1 – Central beam blocked in Zone 1
22C5h, subindex 01h	R	UINT-32	NBB Zone 2 – Number of beams blocked in Zone 2
22C5h, subindex 02h	R	UINT-32	FBB Zone 2 – First beam blocked in Zone 2
22C5h, subindex 03h	R	UINT-32	LBB Zone 2 – Last beam blocked in Zone 2
22C5h, subindex 04h	R	UINT-32	NCBB Zone 2 – Number of consecutive beams blocked in Zone 2
22C5h, subindex 05h	R	UINT-32	CBB Zone 2 – Central beam blocked in Zone 2
22CAh, subindex 01h	R	UINT-32	NBB Zone 3 – Number of beams blocked in Zone 3
22CAh, subindex 02h	R	UINT-32	FBB Zone 3 – First beam blocked in Zone 3
22CAh, subindex 03h	R	UINT-32	LBB Zone 3 – Last beam blocked in Zone 3
22CAh, subindex 04h	R	UINT-32	NCBB Zone 3 – Number of consecutive beams blocked in Zone 3
22CAh, subindex 05h	R	UINT-32	CBB Zone 3 – Central beam blocked in Zone 3
22CFh, subindex 01h	R	UINT-32	NBB Zone 4 – Number of beams blocked in Zone 4
22CFh, subindex 02h	R	UINT-32	FBB Zone 4 – First beam blocked in Zone 4
22CFh, subindex 03h	R	UINT-32	LBB Zone 4 – Last beam blocked in Zone 4
22CFh, subindex 04h	R	UINT-32	NCBB Zone 4 – Number of consecutive beams blocked in Zone 4
22CFh, Subindex 05h	R	UINT-32	CBB Zone 4 – Central beam blocked in Zone 4
22E0h	R	UINT-16	User defined
22E1h	R	UINT-16	User defined
22E2h	R	UINT-16	User defined
22E3h	R	UINT-16	User defined

Table 41: Objects for the teach-in

Object	Access	Data type	Name
2240h	R/W	BOOL	Teach-in
2241h	R	UINT-8	Teach-in result
2242h	R	BOOL	Teach-in required
2243h	R/W	BOOL	Teach-in with blanking
2244h	R/W	BOOL	Blanks blocked beams
2245h	R/W	BOOL	Blanks beams made
2246h, subindex 01h ... 10h	R/W	UINT-32	Beam mask

Table 42: Objects for definition of operating mode/performance options

Object	Access	Data type	Name
2260h	R/W	ENUM8	Operating mode
2261h	R/W	ENUM8	Performance options
2262h	R/W	ENUM8	Minimum detectable absorption
2263h	R/W	STRUCT	Configuration Q1
2264h	R/W	BOOL	Energy saving mode
2265h, subindex 01h	R/W	UINT-16	Switch-off delay Q1 in ms
2265h, subindex 02h	R/W	UINT-16	Switch-off delay Q2 in ms
2265h, subindex 03h	R/W	UINT-16	Switch-off delay Q3 in ms
2265h, subindex 04h	R/W	UINT-16	Switch-off delay Q4 in ms
2265h, subindex 05h	R/W	UINT-16	Switch-off delay Q5 through Q16 in ms

Table 43: Objects with auxiliary resources and diagnostic options

Object	Access	Data type	Name
2270h	R/W	BOOL	Alignment aid
2271h	R	STRUCT	Values for alignment aid
2272h	R/W	ENUM8	“Find Me” function
2273h	R/W	BOOL	Pushbutton lock
2274h	R/W	BOOL	Beam numbering
2276h	R/W	BOOL	Cloning upload
2277h	R/W	BOOL	Cloning download
2278h	R	ENUM8	Cloning status

Table 44: Objects with system information

Object	Access	Data type	Name
2280h	R	STRG (18)	Device name
2281h	R	STRG (32)	Manufacturer name
2282h	R	STRG (7)	Part number
2283h	R	STRG (8)	Serial number
2284h	R	STRG (64)	Product text
2285h	R/W	STRG (32)	Mounting location
2286h	R	STRUCT	Device characteristics
2287h	R	STRG (4)	Hardware revision
2288h	R	STRG (12)	Firmware version

Table 45: Objects with beam evaluation

Object	Access	Data type	Name
2290h, subindex 01h	R/W	UINT-16	Zone measuring: First beam from Zone 1
2290h, subindex 02h	R/W	UINT-16	Zone measuring: Last beam from Zone 1
2290h, subindex 03h	R/W	UINT-16	Zone measuring: First beam from Zone 2
2290h, subindex 04h	R/W	UINT-16	Zone measuring: Last beam from Zone 2
2290h, subindex 05h	R/W	UINT-16	Zone measuring: First beam from Zone 3
2290h, subindex 06h	R/W	UINT-16	Zone measuring: Last beam from Zone 3
2290h, subindex 07h	R/W	UINT-16	Zone measuring: First beam from Zone 4
2290h, subindex 08h	R/W	UINT-16	Zone measuring: Last beam from Zone 4
2298h	R/W	BOOL	Activate Cross beam measuring

Object	Access	Data type	Name
2299h	R/W	ENUM8	Activate BBH – Blocked Beams Hold
229Ah, subindex 01h to 1Ch	R/W	STRUCT	BBH, beam function selection



NOTE

The compatibility objects are only used for replacing predecessor version MLG for an MLG-2. Do not use these objects to implement new applications with the MLG-2.

Table 46: Compatibility objects with the MLG predecessor version

Object	Access	Data type	Name
2300h, subindex 01h ... 1Eh	R	UINT-8	Beam status from maximum 240 beams into 8 bits each
2306h, subindex 01h	R	UINT-8	NBB – Number of Beams Blocked
2306h, subindex 02h	R	UINT-8	NBM – Number of Beams Made
2306h, subindex 03h	R	UINT-8	FBB – First Beam Blocked
2306h, subindex 04h	R	UINT-8	FBM – First Beam Made
2306h, subindex 05h	R	UINT-8	LBB – Last Beam Blocked
2306h, subindex 06h	R	UINT-8	LBM – Last Beam Made
2306h, subindex 07h	R	UINT-8	NCBB – Number of Consecutive Beams Blocked
2306h, subindex 08h	R	UINT-8	NCBM – Number of Consecutive Beams Made
2306h, subindex 09h	R	UINT-8	CBB – Central Beam Blocked
2306h, subindex 10h	R	UINT-8	CBM – Central Beam Made
2306h, subindex 11h	R	UINT-8	ODI – Outside Dimension
2306h, subindex 12h	R	UINT-8	IDI – Inside Dimension
2308h	R	UINT-8	System status
2310h	R	UINT-8	Status of the switching output

7.5 1xxxh – Standard objects

CANopen standard objects are implemented in the MLG-2.

7.5.1 Device type

1000h – Device type

Table 47: 1000h – Device type

Object	Access	Data type	Description
1000h	R	UINT-32	The object contains the device type. The value is always 0, as no device profile is defined for the measuring automation light grid.

7.5.2 Error register

1001h – Error register

Table 48: 1001h – Error register

Object	Access	Data type	Description
1001h	R	UINT-8	The object contains the error register.

The error register is stored in 8 bit:

Table 49: Error register – Stored in 8 bit

Bit 7	Bit 6	Bit 5	Bit 4	Bit 3	Bit 2	Bit 1	Bit 0
Manufacturer-specific error	Reserved	Device profile-related error	Communication error	Temperature error	Voltage error	Current error	Generic error

7.5.3 SYNC message

1005h – COB-ID SYNC message

Table 50: 1005h – COB-ID SYNC message

Object	Access	Data type	Description
1005h	R/W	UINT-32	Determines whether the device generates the SYNC message and if it does, which bit width is used.

Table 51: 1005h – Details

Bit	Description	Data values
31	Reserved	0
30	Determines whether the device generates the SYNC message.	0 Device does not generate a SYNC message. 1 Not supported
29	Determines which bit width is used.	0 11 bit 1 Not supported
28 ... 0	29 bit wide CAN-ID	0
11 ... 0	11 bit wide CAN-ID	80h

7.5.4 Type code

1008h – Device name

Table 52: 1008h – Device name

Object	Access	Data type	Description
1008h	R	STRG	The object contains the type code.

7.5.5 Hardware version

1009h – Hardware version number

Table 53: 1009h – Hardware version number

Object	Access	Data type	Description
1009h	R	STRG	This object contains the revision status of the hardware.

7.5.6 Firmware version

100Ah – Software version number

Table 54: 100Ah – Software version number

Object	Access	Data type	Description
100Ah	R	STRG	This object contains the version of the firmware.

The version of firmware in its delivery state can be found on the type label.

7.5.7 Node guarding

The node guarding telegram is sent to poll the status of the MLG-2 at regular intervals. The monitoring time multiplied by the life time factor results in the cycle in which the MLG-2 is monitored.

100Ch – Guard time

Table 55: 100Ch - Node guarding – Guard time

Object	Access	Data type	Description
100Ch	R/W	UINT-16	Configured monitoring time in ms

100Dh – Life time factor

Table 56: 100Dh - Node guarding – Life time factor

Object	Access	Data type	Description
100Dh	R/W	UINT-8	Factor for multiplication of the monitoring time

7.5.8 COB-ID of the emergency message

1014h – COB-ID emergency message

Table 57: 1014h – COB-ID emergency message

Object	Access	Data type	Description
1014h	R/W	UINT-32	Communication object identifier of the emergency message The value is calculated from 00000080h + node ID 1 ... 127. Example: the MLG-2 with factory-set node ID = 6 transmitted with COB-ID 00000086h.

If the MLG-2 detects an internal error, it sends an emergency message.

The MLG-2 supports the following emergency messages:

Table 58: Emergency messages

Error code of object 1003h	Error register of object 1001h	Manufacturer-specific code					Description
		1	2	3	4	5	
0000h	00h	0	0	0	0	0	No error or reset error
6180h	11h	0	0	0	0	0	The PDO mapping specified in the FBMD file is faulty or there are not enough PDO services available. All PDOs of this direction are locked.
6380h	11h	0	0	0	0	0	A CANopen object has been mapped in several Receive PDOs. No process data is sent to the application controller.
8110h	11h	1	0	0	0	0	CAN overrun The receipt buffer in the CAN controller is full. New messages cannot be saved and are lost.
8110h	11h	2	0	0	0	0	CAN overrun The sender buffer in the CAN controller is full. New messages cannot be sent. The MLG-2 CANopen tries to send an emergency message when the cause is not a busoff or ERROR PASSIVE.
8120h	11h	0	0	0	0	0	The CAN controller switches to ERROR PASSIVE status.

Error code of object 1003h	Error register of object 1001h	Manufacturer-specific code					Description
		1	2	3	4	5	
8130h	11h	ID ¹	0	0	0	0	The heartbeat or node guarding of a CANopen device to be monitored has failed.
8140h	11h	0	0	0	0	0	It was possible to restart the CANopen communication after a busoff. Data can be lost.
8210h	11h	No. ²	0	0 0	0	0	PDO too short The Receive PDO contains too little data. The data is ignored.
8220h	11h	No. ²	0	0	0	0	PDO too long The Receive PDO contains too much data. The redundant data is ignored.

¹ Node ID of the failed device.

² Object number of the affected PDO.

7.5.9 Inhibition time for emergency message

1015h – Emergency inhibition time

Table 59: 1015h – Emergency inhibition time

Object	Access	Data type	Description
1015h	R/W	UINT-16	The configured inhibition time for the emergency message in ms. The inhibition time becomes inactive with value 0.

7.5.10 Heartbeat

The MLG-2 can be monitored with the heartbeat protocol or monitor other bus nodes.

1016h – Consumer heartbeat time

Table 60: 1016h – Consumer heartbeat time

Object Subindex	Access	Data type	Description
1016h	R/W	UINT-16	Cycle time of the heartbeat in ms. The heartbeat becomes inactive with value 0.
00h	R/W	UINT-8	Number of entries
01h	R/W	UINT-32	Node ID and heart beat time of the monitored bus node (see table 61)

Table 61: 1016h – Details

Bit	Description
31 ... 24	Reserved
23 ... 16	Node ID of the monitored bus node
15 ... 0	Heartbeat time of the monitored bus node (typically multiplied by a factor of 1.5)

1017h – Producer heartbeat time

Table 62: 1017h – Producer heartbeat time

Object	Access	Data type	Description
1017h	R/W	UINT-16	Cycle time of the heartbeat in ms. The heartbeat becomes inactive with value 0.

7.5.11 MLG-2 identification values

1018h – Identity object

Table 63: 1018h – Identity object

Object	Access	Data type	Description
1018h	R	RECORD	You use this object to read the following values from the MLG-2: Subindex 01h = Vendor ID (SICK AG) Subindex 02h = Product code Subindex 03h = Revision number (firmware version) Subindex 04h = Serial number

7.6 Standard object for defining process data

The MLG-2 supports 10 Transmit PDOs and 2 Receive PDOs. Each Process Data Object (PDO) has one communication object and one mapping object.

Communication objects specify which COB IDs are used and which transmission type is selected for this.

The mapping objects specify which objects are sent as process data.

The Transmit PDOs are defined by the following objects:

- Objects 1800h to 1809h contain the communication parameters.
- Objects 1A00h to 1A09h contain the object mapping.

The Receive PDOs are defined by the following objects:

- Objects 1400h to 1401h contain the communication parameters.
- Objects 1600h to 1601h contain the object mapping.

While parameters are being changed, no process data is available.

Transmission types

The "Transmission type" parameter (subindex 02h of all PDOs) contains information on when a Transmit PDO is sent or how Receive PDOs received are handled.

Table 64: Transmission types

Transmission type	Transmission type				
	Cyclical	Acyclical	Synchronous	Asynchronous	RTR
0	-	X	X	-	-
1-240	X	-	X	-	-
241-251	Reserved				
252	-	-	X	-	X
253	-	-	-	X	X
254	-	-	-	X	-

Transmission type 0: Acyclical and synchronous data transmission

During acyclical and synchronous data transmission, only one Transmit PDO is sent if the MLG-2 receives a SYNC message and the beam status of the MLG-2 has changed.

For an Receive PDO, this transmission type means that the data received is evaluated only after receiving the next SYNC message.

Transmission type 1 to 240: Cyclical and synchronous data transmission

With synchronous and cyclical data transmission, a Transmit PDO is not sent until after a certain number of SYNC message have been received. This number may be between 1 and 240. A Receive PDO is processed after the reception of the next SYNC message.

**NOTE**

When operating in networks with a cycle time of less than the response time of the MLG-2, it is possible that individual SYNC message are not detected.

**NOTE**

For applications with temporary web server/SOPAS access, a cycle time of at least 3 ms is recommended.

Transmission type 252 and 253: RTR data transmission**NOTE**

Transmission types 252 and 253 are only permissible for Transmit PDOs.

Some bus module manufacturers do not support RTR data transmission. For this reason, we do not recommend using transmission types 252 and 253.

RTR stands for "Remote Transmission Request". With RTR data transmission, data is only transferred after an RTR frame has been received.

With synchronous RTR data transmission (transmission type 252), the process data is redetermined every time a SYNC message is received. A Transmit PDO is not transmitted until the RTR frame has been received.

With asynchronous RTR data transmission (transmission type 253), the current values are constantly determined. A Transmit PDO is not transmitted until the RTR frame has been received.

Transmission type 254: Asynchronous data transmission

In asynchronous data transmission, Transmit PDOs are transmitted in an event-controlled process. This means transmission occurs every time the beam status of the MLG-2 changes.

A Receive PDO is evaluated immediately after it is received.

This transmission type can be linked with the event timer.

**NOTE**

Transmission type 255 is not supported by MLG-2.

Dynamic PDO mapping

Mapping objects are used to define which parameters and data are to be used. In the mapping object, links are created to objects from the object directory. Objects linked in the mapping object are sent in Process Data Objects (PDOs).

Subindex 00h for a mapping object specifies the number of linked objects. If a new object is linked, the device tests the validity of the link. If the linked object is not available or cannot be linked, an error message will be triggered.



NOTE

The dynamic PDO mapping is permanently saved in the MLG-2.

7.6.1 Communication parameter of the Receive PDOs

1400h ... 1401h – Communication parameter for Receive PDOs

Table 65: 1400h to 1401h

Object Subindex	Access	Data type	Description	
1400h ... 1401h	R/W	RECORD	Communication parameter of the Receive PDOs	
00h	R	UINT-8	Number of entries	
01h	R/W	UINT-32	Bit	Description
			31	0: PDO is being used 1: PDO is not being used
			30	0: reacts to RTR 1: does not react to RTR
			29	0: 11 bit identifier (CAN 2.0A) 1: 29 bit identifier (CAN 2.0B)
			28 ... 0	COB-ID = 0200h + node ID
02h	R/W	UINT-8	Transmission type	Description
			0	Data is synchronized, but not cyclically sent
			1 ... 240	Cyclic transmission Clocked with the SYNC messages
			252	Query by the RTR telegram (synchronous transmission)
			253	Query by the RTR telegram (asynchronous transmission)
			254	Event-controlled transmission when beam status changes
03h	R/W	UINT-16	Inhibition time = Idle time between two transmissions (× 0.1 ms)	
04h	–	–	Reserved	
05h	R/W	UINT-16	Event timer = Timer for application-specific triggering (× 1 ms)	

7.6.2 Mapping parameter of the Receive PDOs

1600h – Mapping parameter for the 1st Receive PDO

Table 66: 1600h – Mapping configured at the factory

Object Subindex	Access	Data type	Description
1600h	R/W	RECORD	Mapping parameter of the first Receive PDO
00h	R/W	UINT-8	Number of entries = 0 = PDO is deactivated

1601h – Mapping parameter for the 2nd Receive PDO

Table 67: 1601h – mapping configured at the factory

Object Subindex	Access	Data type	Description
1601h	R/W	RECORD	Mapping parameter of the second Receive PDO
00h	R/W	UINT-8	Number of entries = 0 = PDO is deactivated

In the subindexes, the index, the subindex and the width of the affected Receive PDO sub-area are specified as follows:

Table 68: Mapping

Bits 31 ... 16	Bits 15 ... 8	Bits 7 ... 0
Index of the mapped object	Subindex of the mapped object	Length in bits

7.6.3 Communication parameter of the Transmit PDOs

The first two Transmit PDOs are activated at the factory using objects 1800h and 1801h. The remaining Transmit PDOs are deactivated using objects 1802h to 1809h.

1800h ... 1809h – Communication parameter for Transmit PDOs

Table 69: 1800h to 1809h

Object Subindex	Access	Data type	Description	
1800h ... 1809h	R/W	RECORD	Communication parameter of the Transmit PDOs	
00h	R	UINT-8	Number of entries	
01h	R/W	UINT-32	Bit	Description
			31	0: PDO is being used 1: PDO is not being used
			30	0: reacts to RTR 1: does not react to RTR
			29	0: 11 bit identifier (CAN 2.0A) 1: 29 bit identifier (CAN 2.0B)
			28 ... 0	COB-ID = 0200h + node ID
02h	R/W	UINT-8	Transmission type	Description
			0	Data is synchronized, but not cyclically sent
			1 ... 240	Cyclic transmission Clocked with the SYNC messages
			252	Query by the RTR telegram (synchronous transmission)
			253	Query by the RTR telegram (asynchronous transmission)
			254	Event-controlled transmission when beam status changes
03h	R/W	UINT-16	Inhibition time = Idle time between two transmissions (× 0.1 ms)	
04h	-	-	Reserved	
05h	R/W	UINT-16	Event timer = Timer for application-specific triggering (× 1 ms)	

Inhibition time

The inhibition time (configured in objects 1800.03h to 1809.03h) in principle limits the communication of a device on the CANopen bus.

The inhibition time does not influence the triggering by RTR telegrams.

The inhibition time (transmit delay time) specifies the minimum waiting time in ms between the transmission of two identical Transmit PDOs. It always has higher priority than the event timer, the CoS events and triggering with SYNC messages. If, for example, the event timer is set to 100 ms and the inhibition time to 1 s, the respective PDO is only sent every second.



NOTE

Some bus module manufacturers do not support use of inhibition time. We recommend using synchronous communication if you want to control the bus load.

Event timer

Subindex 05h of the Transmit PDOs contains an event timer. It runs in the background and triggers an event when it expires. This means if no event occurs in the purely asynchronous transmission type (beam status change), a Transmit PDO will be sent when the set event time (in 1 ms increments) expires. No event timer can be set for the Receive PDO of the MLG-2.



NOTE

For applications with temporary web server or SOPAS access, a cycle time of at least 3 ms is recommended.

7.6.4 Mapping parameter of the Transmit PDOs

Mappings are preconfigured at the factory for the 1A00h and 1A01h objects. No objects are mapped at the factory in the subindexes of the 1A02h to 1A09h objects.

1A00h – Mapping parameter for the 1st Transmit PDO

Table 70: 1A00h – mapping configured at the factory

Object Subindex	Access	Data type	Description
1A00h	R/W	RECORD	Mapping parameter of the first Transmit PDO
00h	R/W	UINT-8	Number of entries
01h	R/W	UINT-32	2200.01h – NBB
02h	R/W	UINT-32	2200.03h – FBB
03h	R/W	UINT-32	2200.05h – LBB
04h	R/R	UINT-32	2200.0Bh – ODI

1A01h – Mapping parameter for the 2nd Transmit PDO

Table 71: 1A01h – mapping configured at the factory

Object Subindex	Access	Data type	Description
1A01h	R/W	RECORD	Mapping parameter of the second Transmit PDO
00h	R/W	UINT-8	Number of entries
01h	R/W	UINT-32	2200.0Ch – IDI
02h	R/W	UINT-32	2210h – Status of the switching output and the virtual switching outputs

Object Subindex	Access	Data type	Description
03h	R/W	UINT-32	2211h – System status

1A02 ... 1A09h – Mapping parameter for Transmit PDOs

Table 72: 1A02 to 1A09h – Mapping configured at the factory

Object Subindex	Access	Data type	Description
1A02h ... 1A09h	R/W	RECORD	Mapping parameter of the remaining Transmit PDOs
00h	R/W	UINT-8	Number of entries = 0 = PDOs are deactivated

How to change the content of the mapping objects:



NOTE

Parameter changes to the PDO mapping objects are only made in Pre-operational status.

1. First, set bit 31 to 1 in corresponding object 180xh in subindex 01h.
2. Set subindex 00h to 0 in object 1A0xh.
3. Configure the objects to be mapped in subindexes 01h to n of object 1A0xh.
4. Set subindex 00h of object 1A0xh to the number of mapped objects.
5. Then set bit 31 back to 0 in corresponding object 180xh in subindex 01h.

In the subindexes, the index, the subindex and the width of the affected Receive PDO sub-area are specified as follows:

Table 73: Mapping

Bits 31 ... 16	Bits 15 ... 8	Bits 7 ... 0
Index of the mapped object	Subindex of the mapped object	Length in bits

7.7 2xxxh – Manufacturer-specific objects

7.7.1 Objects with process data

7.7.1.1 Beam functions

Table 74: Beam functions

Object	Access	Data type	Description
2200h	R	RECORD 16 × UINT-16	You use this object to read the predefined beam functions from the MLG-2.

NBB – Number of Beams Blocked

Table 75: NBB

Subindex	Access	Data type	Description
01h	R	UINT-16	The subindex contains the number of blocked beams.

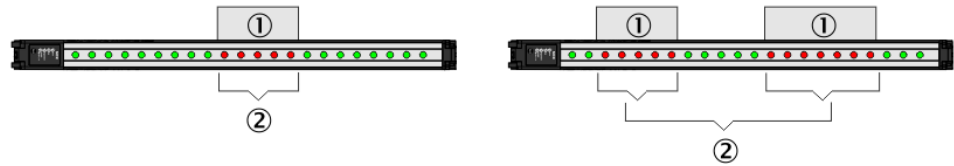

Figure 54: Beam function NBB

- ① Objects in detection area
- ② Number of beams blocked

The beam function facilitates object detection, for example.

- If there are several objects in the detection area (example on right), then all blocked beams are totaled.

NBM – Number of Beams Made

Table 76: NBM

Subindex	Access	Data type	Description
02h	R	UINT-16	The subindex contains the number of beams made.

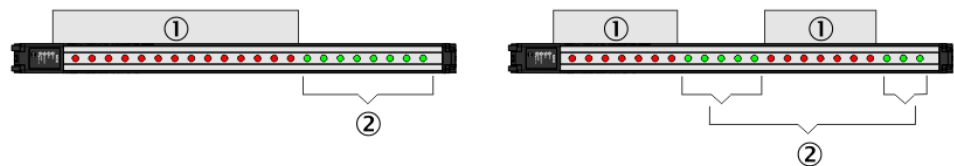

Figure 55: Beam function NBM

- ① Objects in detection area
- ② Number of beams made

The beam function facilitates hole detection, for example.

- If there are several gaps in the detection area (example on right), then all beams made are totaled.

FBB – First Beam Blocked

Table 77: FBB

Subindex	Access	Data type	Description
03h	R	UINT-16	The subindex contains the number of the first beam blocked.

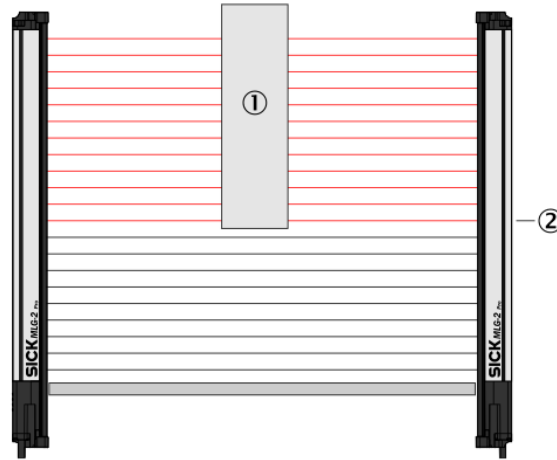

Figure 56: Beam function FBB

- ① Object in detection area
- ② First Beam Blocked

The beam function facilitates the height classification of a hanging object, for example.

- The count direction of the beams depends on the configured beam numbering.

FBM – First Beam Made

Table 78: FBM

Subindex	Access	Data type	Description
04h	R	UINT-16	The subindex contains the number of the first beam made.

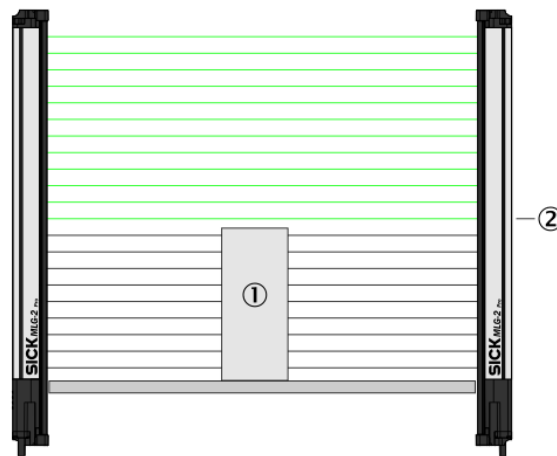

Figure 57: Beam function FBM

- ① Object in detection area
- ② First Beam Made

The beam function facilitates the height classification of a standing object, for example.

- The count direction of the beams depends on the configured beam numbering.

LBB – Last Beam Blocked

Table 79: LBB

Subindex	Access	Data type	Description
05h	R	UINT-16	The subindex contains the number of the last beam blocked.

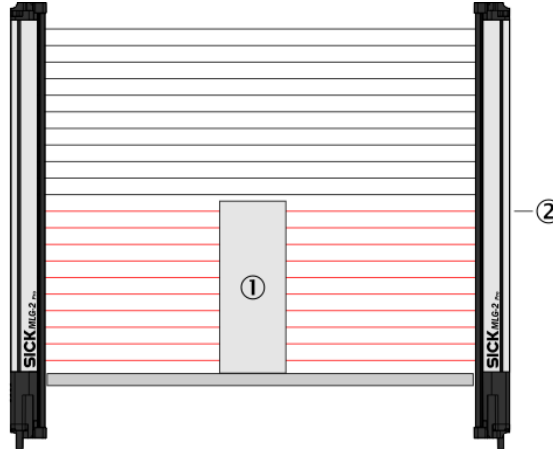

Figure 58: Beam function LBB

- ① Object in detection area
- ② Last Beam Blocked

The beam function facilitates object height measurement, for example.

- The count direction of the beams depends on the configured beam numbering.

LBM – Last Beam Made

Table 80: LBM

Subindex	Access	Data type	Description
06h	R	UINT-16	The subindex contains the number of the last beam made.

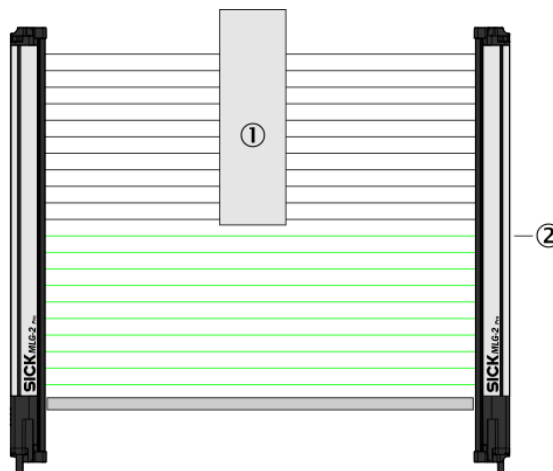

Figure 59: Beam function LBM

- ① Object in detection area
- ② Last beam made

The beam function facilitates the object measurement of a hanging object, for example.

- The count direction of the beams depends on the configured beam numbering.

NCBB – Number of Consecutive Beams Blocked

Table 81: NCBB

Subindex	Access	Data type	Description
07h	R	UINT-16	The subindex contains the total number of consecutive beams blocked.

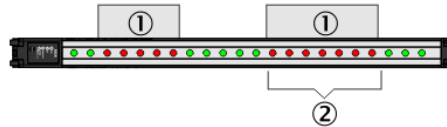

Figure 60: Beam function NCBB

- ① Objects in detection area
- ② Total number of consecutive beams blocked

The beam function facilitates object detection, for example.

- If there are several objects in the detection area, the number of beams of the largest object is output.
- If there are several objects of the same size in the detection area, the object with the lowest-value beam is used for the measurement.

NCBM – Number of Consecutive Beams Made

Table 82: NCBM

Subindex	Access	Data type	Description
08h	R	UINT-16	The subindex contains the total number of consecutive beams made.

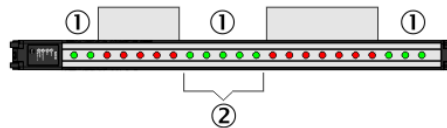

Figure 61: Beam function NCBM

- ① Gaps in detection area
- ② Total number of consecutive beams made

The beam function facilitates hole detection, for example.

- If there are several gaps in the detection area, the number of beams of the largest free field is output.
- If there are several gaps of the same size in the detection area, the gap with the lowest-value beam is used for the measurement.

CBB – Central Beam Blocked

Table 83: CBB

Subindex	Access	Data type	Description
09h	R	UINT-16	The subindex contains the beam number of the central beam blocked.

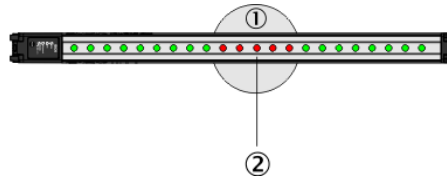

Figure 62: Beam function CBB

- ① Object in detection area
- ② Central Beam Blocked

The beam function facilitates object position measurement, for example.

- The count direction of the beams depends on the configured beam numbering.
- If the object blocks an even number of beams, the lowest-value beam of the “two central beams” is rated as the central beam blocked.
- If there are several objects in the detection area, the largest object is used for the measurement.

CBM – Central Beam Made

Table 84: CBM

Subindex	Access	Data type	Description
0Ah	R	UINT-16	The subindex contains the beam number of the central beam made.

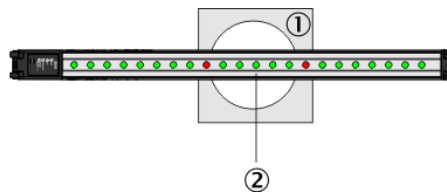

Figure 63: Beam function CBM

- ① Object in detection area
- ② Central beam made

The beam function facilitates hole position measurement, for example.

- The count direction of the beams depends on the configured beam numbering.
- If the hole makes an even number of beams, the lowest-value beam of the “two central beams” is rated as the central beam made.
- If there are several holes in the detection area, the largest hole is used for the measurement.

ODI – Outside Dimension

Table 85: ODI

Subindex	Access	Data type	Description
0Bh	R	UINT-16	The subindex contains an object's outside dimension.

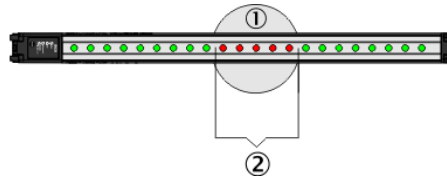

Figure 64: Beam function ODI

- ① Object in detection area
- ② Outside dimension

The beam function facilitates outside dimension measurement, for example.

- If there are several objects in the detection area, then the blocked beams of the objects are totaled.

IDI – Inside Dimension

Table 86: IDI

Subindex	Access	Data type	Description
0Ch	R	UINT-16	The subindex contains an object's inside dimension.

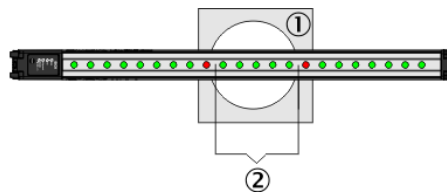

Figure 65: Beam function IDI

- ① Object in detection area
- ② Inside dimension

The beam function facilitates inside dimension measurement of a hole, for example.

- If there are several holes in the detection area, then the beams made within the objects are totaled.

7.7.1.2 Status of the switching output and the virtual switching outputs

QS – Switching output status

Table 87: QS – Switching output status

Object	Access	Data type	Description
2210h	R	UINT-16	You use this object to read the status of the switching output Q1 and the status of the virtual switching outputs Q2 ... Q16. Bit 0 = Q1 (physical output) Bit 1 ... 15 = Q2 ... Q16 (virtual outputs) 0 = output not active 1 = output active

The status of a switching output depends on the following factors:

- The application assigned in SOPAS ET
- The function programming assigned in SOPAS ET or in the fieldbus functions

The following is set at the factory:

- Switching output Q1 = NBB ≥1
- Virtual switching outputs = no function

**NOTE**

These virtual switching outputs can only be configured in SOPAS ET (see "Measuring and diagnostic functions for switching outputs", page 120).

7.7.1.3 System status**SYS – System status**

Table 88: SYS – System status

Object	Access	Data type	Description
2211h	R	UINT-16	You use this object to read the system status.

The system status is stored in 8 bit:

Table 89: Details of the system status

Bit 15 ... 8	Bit 7	Bit 6	Bit 5	Bit 4	Bit 3	Bit 2	Bit 1	Bit 0
Reserved	Synchronization error	Teach-in error	Hardware error	Contamination	Teach-in active	Overtemperature	Process data invalid	Short-circuit at switching output

7.7.1.4 Process quality**QoR – Quality of Run (process quality)**

Table 90: QoR – Quality of Run (process quality)

Object	Access	Data type	Description
2212h	R	UINT-16	You use this object to read the MLG-2's process quality. 00h = 0% 64h = 100%

The process quality indicates the quality of the light level currently being received. The MLG-2 analyzes the light level received when the light path is unblocked and compares this to the values after the last teach-in process.

If the received values are getting worse, the process quality drops.

Possible causes of a drop in process quality include:

- Contamination or fogging of the front screen of the sender and/or receiver
- Misalignment
- Continuous partial blocking of a light beam or several light beams

7.7.1.5 Teach-in quality**QoT – Quality of Teach (teach-in quality)**

Table 91: QoT – Quality of Teach (teach-in quality)

Object	Access	Data type	Description
2213h	R	UINT-16	You use this object to read the quality of the last teach-in process. 00h = unsuccessful 64h = successful

The teach-in quality indicates how successful the teach-in process has been. The MLG-2 calculates this value based on the quality of the light level received.

The value remains constant until another teach-in process is carried out.

7.7.1.6 Run-length code

RLC – Run-length code

Table 92: Run-length code

Object	Subindex	Access	Data type	Description
2220h		R	UINT-16	You use the subindexes of this object to read the MLG-2's run-length code.
	01h	R		RLC1
	...	R		...
	10h	R		RLC16

The “run-length code” can be output instead of the complete status of all beams. This code only contains the status change of the beams.



NOTE

The run-length code can contain a maximum of 16 values, i.e., 15 status changes. It is therefore only useful for measuring objects with a small number of parts, e.g., a pallet. Objects such as pallet cages are not suitable as they involve too many status changes.

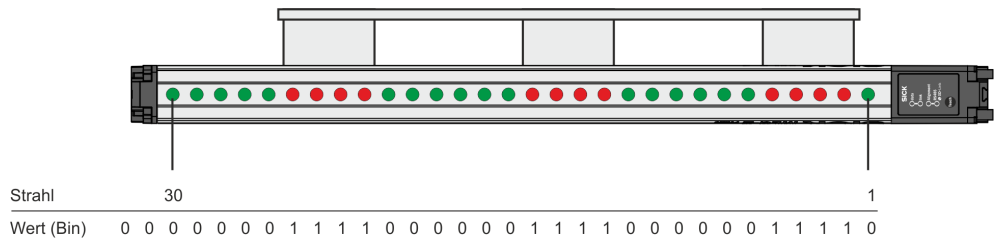

Figure 66: Beam status – Example 1

- The green beams have been made.
- The red beams have been blocked.
- The bits represent the status of the beams on the MLG-2 (made = logical 0, broken = logical 1).
- The count direction of the beams depends on the configured beam numbering (in the example, beam 1 on the connection side).

The run-length code indicates how many beams currently have the same status.

Table 93: Example run-length code with 30 beams

Beams 1 ... 30																													
0	1	1	1	1	0	0	0	0	0	0	1	1	1	1	0	0	0	0	0	0	1	1	1	1	0	0	0	0	0
RLC1	RLC2				RLC3						RLC4				RLC5						RLC6				RLC8				
1	4				6						4				6						4				5				

RLC = 1464645

The example shows: 1 beam made, 4 beams blocked, 6 beams made, 4 beams blocked, 6 beams made, 4 beams blocked, 5 beams made.

Table 94: Example run-length code with the first beam blocked

		Beams 1 ... 30																													
-		1	1	1	1	1	0	0	0	0	0	0	1	1	1	1	0	0	0	0	0	0	1	1	1	1	0	0	0	0	0
R L C 1		RLC2					RLC3					RLC4			RLC5					RLC6			RLC8								
	0	5					6					4			6					4			5								

RLC = 0564645

The RLC1 **always** indicates the number of beams **made**. If the first beam is blocked, the RLC1 will therefore be zero. Only the RLC2 indicates how many beams are blocked; in the example, this value = 5.

7.7.1.7 Beam status

Table 95: Beam status

Object	Sub-index	Access	Data type	Description
2230h		R	UINT-32	You use the subindexes of this object to read the MLG-2's beam status.
	01h	R		Subindex 01h contains beams 1 ... 32.
	02h	R		Subindex 02h contains beams 33 ... 64.
	...	R		...
	10h	R		Subindex 10h contains beams 481 ... 512.

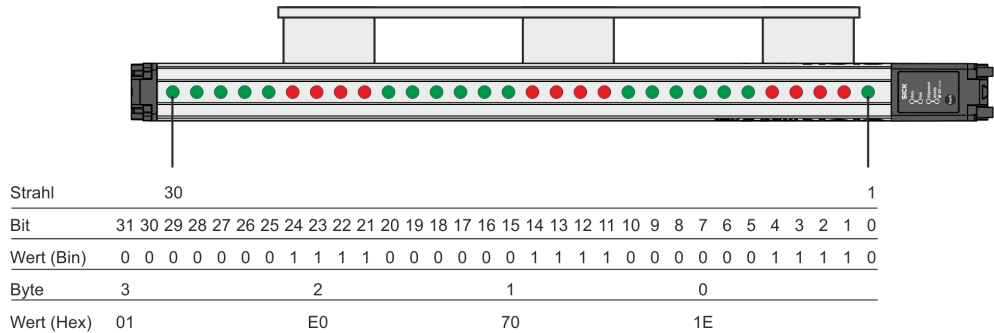

Figure 67: Beam status – Example 2

This example shows an MLG-2 with 30 beams.

- The green beams have been made.
- The red beams have been blocked.
- The bits represent the status of the beams on the MLG-2 (made = logical 0, broken = logical 1).
- Beam 1 is represented by bit 0; beam 30 by bit 29.
- Superfluous bits receive the status logical 0 (in the example, bits 30 and 31).
- The count direction of the beams depends on the configured beam numbering (in the example, beam 1 on the connection side).

7.7.1.8 Beam functions for Zone measuring

Table 96: Beam functions for Zone measuring

Object	Subindex	Access	Data type	Name	Description
22C0h	01h	R	UINT-16	NBB Zone 1 – Number of beams blocked in Zone 1	This subindex transfers the number of blocked beams in Zone 1.
	02h	R	UINT-16	FBB Zone 1 – First beam blocked in Zone 1	This subindex transfers the number of the first blocked beam in Zone 1.
	03h	R	UINT-16	LBB Zone 1 – Last beam blocked in Zone 1	This subindex transfers the number of the last blocked beam in Zone 1.
	04h	R	UINT-16	NCBB Zone 1 – Number of consecutive beams blocked in Zone 1	This subindex transfers the total number of consecutive beams blocked in Zone 1.
	05h	R	UINT-16	CBB Zone 1 – Central beam blocked in Zone 1	This subindex transfers the beam number of the central beam blocked in Zone 1.
22C5h	01h	R	UINT-16	NBB Zone 2 – Number of beams blocked in Zone 2	This subindex transfers the number of blocked beams in Zone 2.
	02h	R	UINT-16	FBB Zone 2 – First beam blocked in Zone 2	This subindex transfers the number of the first blocked beam in Zone 2.
	03h	R	UINT-16	LBB Zone 2 – Last beam blocked in Zone 2	This subindex transfers the number of the last blocked beam in Zone 2.
	04h	R	UINT-16	NCBB Zone 2 – Number of consecutive beams blocked in Zone 2	This subindex transfers the total number of consecutive beams blocked in Zone 2.
	05h	R	UINT-16	CBB Zone 2 – Central beam blocked in Zone 2	This subindex transfers the beam number of the central beam blocked in Zone 2.

Object	Subindex	Access	Data type	Name	Description
22CAh	01h	R	UINT-16	NBB Zone 3 – Number of beams blocked in Zone 3	This subindex transfers the number of blocked beams in Zone 3.
	02h	R	UINT-16	FBB Zone 3 – First beam blocked in Zone 3	This subindex transfers the number of the first blocked beam in Zone 3.
	03h	R	UINT-16	LBB Zone 3 – Last beam blocked in Zone 3	This subindex transfers the number of the last blocked beam in Zone 3.
	04h	R	UINT-16	NCBB Zone 3 – Number of consecutive beams blocked in Zone 3	This subindex transfers the total number of consecutive beams blocked in Zone 3.
	05h	R	UINT-16	CBB Zone 3 – Central beam blocked in Zone 3	This subindex transfers the beam number of the central beam blocked in Zone 3.
22CFh	01h	R	UINT-16	NBB Zone 4 – Number of beams blocked in Zone 4	This subindex transfers the number of blocked beams in Zone 4.
	02h	R	UINT-16	FBB Zone 4 – First beam blocked in Zone 4	This subindex transfers the number of the first blocked beam in Zone 4.
	03h	R	UINT-16	LBB Zone 4 – Last beam blocked in Zone 4	This subindex transfers the number of the last blocked beam in Zone 4.
	04h	R	UINT-16	NCBB Zone 4 – Number of consecutive beams blocked in Zone 4	This subindex transfers the total number of consecutive beams blocked in Zone 4.
	05h	R	UINT-16	CBB Zone 4 – Central beam blocked in Zone 4	This subindex transfers the beam number of the central beam blocked in Zone 4.

7.7.1.9 User-defined beam functions

These objects are reserved for use at a later point in time and currently cannot be used.

Table 97: User-defined beam functions

Object	Access	Data type	Name
22E0h	R	UINT-16	User defined 1
22E1h	R	UINT-16	User defined 2
22E2h	R	UINT-16	User defined 3
22E3h	R	UINT-16	User defined 4

7.7.2 Objects for the teach-in function

7.7.2.1 Teach-in

Table 98: Teach-in

Object	Access	Data type	Description
2240h	R/W	BOOL	You use this object to start a teach-in on the MLG-2. 0 = no teach-in 1 = start teach-in A change from 0 to 1 always initiates a teach-in. If an additional teach-in is to be initiated, this object must first be described using 0.

During the teach-in process, the switching thresholds for all beams are individually adjusted for the sensing range and the ambient conditions.

A teach-in process must be carried out when commissioning, when changing operating mode or performance options, and at regular intervals in general.

7.7.2.2 Teach-in result

Table 99: Teach-in result

Object	Access	Data type	Description
2241h	R	UINT-8	You use this object to read the result of the last teach-in.

The teach-in result is stored in 8 bit:

Table 100: Teach-in result – Stored in 8 bit

Bit 7	Bit 6	Bit 5	Bit 4	Bit 3	Bit 2	Bit 1	Bit 0
Warning: no automatic teach-in possible	Error: occurred when blanking beams during teach-in	Warning: high-speed scan not possible	Error: occurred with cross-beam function during teach-in	Warning: beam signal strength too high	Warning: beam signal strength too low	Error: occurred with parallel-beam function during teach-in	Error: general error occurred during teach-in

7.7.2.3 Teach-in required

Table 101: Teach-in required

Object	Access	Data type	Description
2242h	R	BOOL	You use this object to read whether a teach-in is required. 0 = no teach-in required 1 = teach-in required

7.7.2.4 Teach-in with blanking

Table 102: Teach-in with blanking

Object	Access	Data type	Description
2243h	R/W	BOOL	This parameter activates a beam blanking with each teach-in. 0 = no blanking 1 = with blanking

To show the blanked beams again, proceed as follows:

1. Remove all objects from the detection area.
2. Activate the **Blank blocked beams** function.
3. Activate the **Teach-in with blanking** function.
4. Perform a teach-in.

7.7.2.5 Blanking blocked beams

Table 103: Blank blocked beams

Object	Access	Data type	Description
2244h	R/W	BOOL	You use this object to blank the blocked beams for later measurements. 0 = no blanking 1 = blank the beams A change from 0 to 1 always initiates a blanking of blocked beams. If the beams are to be blanked again, this object must first be described using 0.

The beams from the MLG-2 that are **not** to be accounted for in the measurement must be blocked.

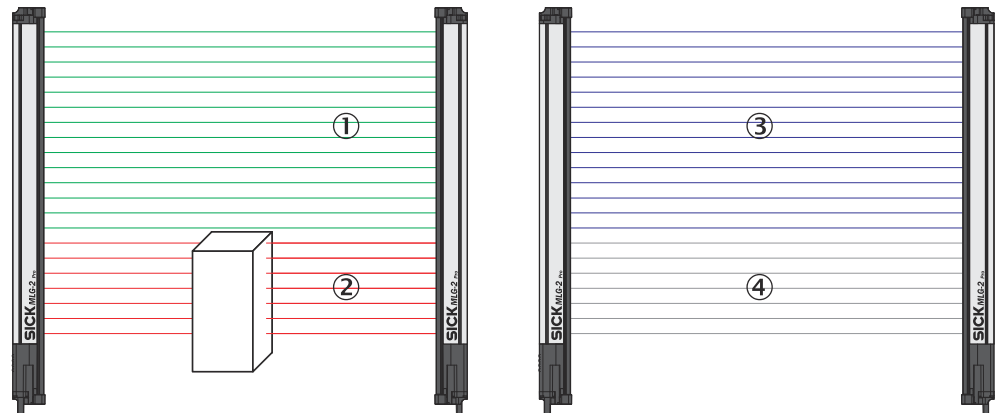

Figure 68: Example of the blanking of blocked beams

- ① Made beams
- ② Blocked beams
- ③ Beams included in the measurement
- ④ Excluded beams

7.7.2.6 Blanking beams made

Table 104: Blanking beams made

Object	Access	Data type	Description
2245h	R/W	BOOL	You use this object to blank the made beams for later measurements. 0 = no blanking 1 = blank the beams A change from 0 to 1 always initiates a blanking of beams made. If the beams are to be blanked again, this object must first be described using 0.

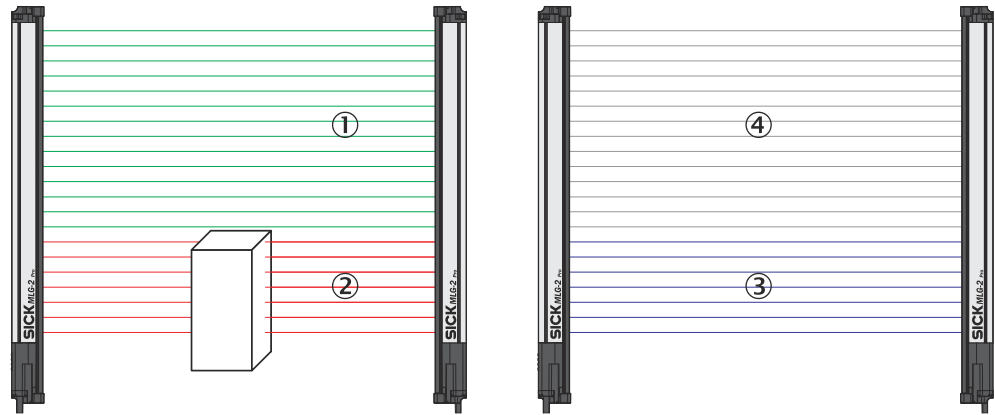

Figure 69: Example of blanking made beams

- ① Made beams
- ② Blocked beams
- ③ Beams included in the measurement
- ④ Excluded beams

The made beams will not be taken into account in the measurement.

7.7.2.7 Beam mask

Table 105: Beam mask

Object	Subindex	Access	Data type	Description
2246h		R/W	UINT-32	You use this object to blank the beams from the MLG-2 for measurement purposes. 0 = beam is blanked 1 = beam is included in the measurement
	01h	R/W		Subindex 01h contains beams 1 ... 32.
	02h	R/W		Subindex 02h contains beams 33 ... 64.
	...	R/W		...
	10h	R/W		Subindex 10h contains beams 481 ... 512.

The beams can be blanked using a bit-coded beam mask. This example shows the bit-coded beam mask for an MLG-2, with 30 beams.

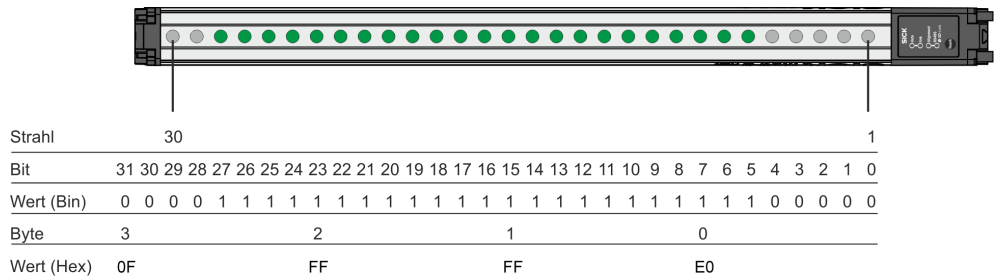

Figure 70: Bit-coded beam mask for an MLG-2, with 30 beams

7.7.3 Objects for definition of operating mode and performance options

7.7.3.1 Operating mode

Table 106: Operating mode

Object	Access	Data type	Description
2260h	R/W	ENUM8	You use this object to set the MLG-2 to the respective operating mode. 0 = standard 1 = transparent 2 = dust- and sunlight-resistant

The MLG-2 has the following operating modes:

- **Standard**
For normal measuring tasks involving opaque objects (recommended for the majority of applications)
- **Transparent**
For transparent objects, e.g., made of glass, PET, etc.
- **Dust- and sunlight-resistant**
For applications when there is a large amount of dust in the environment or a high level of solar radiation



NOTE

When the operating mode is changed, a new teach-in process must be performed.

7.7.3.2 Performance options

Table 107: Performance options

Object	Access	Data type	Description
2261h	R/W	ENUM8	You use this object to specify performance options for the MLG-2. 0 = standard measurement accuracy 1 = high measurement accuracy 2 = high operating reserve 3 = cross-beam function 4 = cross-beam function with high operating reserve 5 = high-speed scan 6 = high-speed scan with high measurement accuracy 7 = high-speed scan with high operating reserve

Standard measurement accuracy

In order for an object to be detected, it must completely cover at least one beam (see ["Minimum detectable object with parallel-beam function"](#), page 21).

High measurement accuracy

On the MLG-2, the measurement accuracy can be increased in SOPAS ET. This means that an object can be detected even if it only covers half of a beam (see ["Minimum detectable object with high measurement accuracy from the MLG-2"](#), page 24). When the configured measurement accuracy is high, the MLG-2 cleaning and teach-in processes must be performed more frequently.

High operating reserve

Setting the operating reserve high makes the MLG-2 very resistant to contamination (see "Operating reserve", page 25). However, it is not possible to activate high measurement accuracy in this case.

Cross beam function

When the cross-beam function is enabled, the light beam from a sender LED is received by three receiver diodes in two scans. This doubles the scan time.(see "Minimum detectable object with cross-beam function ", page 23).

High-speed scan

With high-speed scan, several beams are active in each cycle. This reduces the scan time by a variable factor (see "Scan time with high-speed scan on the MLG-2", page 20).

7.7.3.3 Minimum detectable absorption

Table 108: Minimum detectable absorption

Object	Access	Data type	Description
2262h	R/W	ENUM8	You use this object to specify the minimum detectable absorption for Transparent operating mode (see "Transparent operating mode", page 25). 0 = signal attenuation 30% 1 = signal attenuation 15% 2 = signal attenuation 10%

7.7.3.4 Configuration Q1

Table 109: Configuration Q1

Object	Access	Data type	Description
2263h	R/W	STRUCT	You use this object to define program functions for switching output Q1.
		ENUM8	Subindex 01h = Operand 1
		ENUM8 UINT16	Subindex 02h = Operator Subindex 03h = Operand 2

Table 110: Byte sequence of 2263h

Byte 0	Byte 1	Byte 2	Byte 3
Operand 1	Operator	Operand 2	
ENUM8	ENUM8	UINT-16	

You can use operands and operators to realize functions for the switching output.

Example:

Operand 1 = 2; equates to the number of beams made (NBM)

Operator = 1; equates to \geq

Operand 2 = 30

Output Q1 switches when the total number of beams made is greater than or equal to 30.

Operand 1

Table 111: Selectable beam functions

Value	Name	Description
0	NBB	Total number of beams blocked (e.g., for object detection)
1	NBM	Total number of beams made (e.g., for hole detection)
2	FBB	Beam number of the first beam blocked (e.g., for height classification of a hanging object)
3	FBM	Beam number of the first beam made
4	LBB	Beam number of the last beam blocked (e.g., for object height measurement)
5	LBM	Beam number of the last beam made
6	NCBB	Number of consecutive beams blocked (e.g., for object detection). If there are multiple objects in the detection area, the greatest number of consecutive beams blocked is displayed.
7	NCBM	Number of consecutive beams made (e.g., for hole detection). If there are multiple gaps in the detection area, the greatest number of consecutive beams made is displayed.
8	CBB	Beam number of the central beam blocked (e.g., for measuring an object position)
9	CBM	Beam number of the central beam made (e.g., for measuring a hole position)
10	ODI	Total number of beams between the first and last beams blocked (e.g., for measuring the outside dimension)
11	IDI	Total number of beams made between the first and last beams blocked (e.g., for measuring the inside dimension)
12	BNB	True when a predefined beam is blocked
13	BNM	True when a predefined beam is made
14	ALARM Q1	Configuration same as with SOPAS ET
15	QoR (process quality)	0 ... 100 in percent
16	QoT (teach-in quality)	0 or 100 in percent 0 = teach-in was unsuccessful 100 = teach-in was successful
17 ... 32	RLC1 ... 16	Outputs the value of the relevant change
33	NBB Zone 1	Total number of beams blocked in Zone 1 (e.g., for object detection)
34	FBB Zone 1	Beam number of the first beam blocked in Zone 1 (e.g., for height classification of a hanging object)
35	LBB Zone 1	Beam number of the last beam blocked in Zone 1 (e.g., for object height measurement)
36	NCBB Zone 1	Number of consecutive beams blocked in Zone 1 (e.g., for object detection). If there are multiple objects in the detection area, the greatest number of consecutive beams blocked is displayed.
37	CBB Zone 1	Beam number of the central beam blocked in Zone 1 (e.g., for measuring an object position)

Value	Name	Description
38	NBB Zone 2	Total number of beams blocked in Zone 2 (e.g., for object detection)
39	FBB Zone 2	Beam number of the first beam blocked in Zone 2 (e.g., for height classification of a hanging object)
40	LBB Zone 2	Beam number of the last beam blocked in Zone 2 (e.g., for object height measurement)
41	NCBB Zone 2	Number of consecutive beams blocked in Zone 2 (e.g., for object detection). If there are multiple objects in the detection area, the greatest number of consecutive beams blocked is displayed.
42	CBB Zone 2	Beam number of the central beam blocked in Zone 2 (e.g., for measuring an object position)
43	NBB Zone 3	Total number of beams blocked in Zone 3 (e.g., for object detection)
44	FBB Zone 3	Beam number of the first beam blocked in Zone 3 (e.g., for height classification of a hanging object)
45	LBB Zone 3	Beam number of the last beam blocked in Zone 3 (e.g., for object height measurement)
46	NCBB Zone 3	Number of consecutive beams blocked in Zone 3 (e.g., for object detection). If there are multiple objects in the detection area, the greatest number of consecutive beams blocked is displayed.
47	CBB Zone 3	Beam number of the central beam blocked in Zone 3 (e.g., for measuring an object position)
48	NBB Zone 4	Total number of beams blocked in Zone 4 (e.g., for object detection)
49	FBB Zone 4	Beam number of the first beam blocked in Zone 4 (e.g., for height classification of a hanging object)
50	LBB Zone 4	Number of consecutive beams blocked in Zone 4 (e.g., for object detection). If there are multiple objects in the detection area, the greatest number of consecutive beams blocked is displayed.
51	NCBB Zone 4	Beam number of the central beam blocked in Zone 4 (e.g., for measuring an object position)
52	CBB Zone 4	Total number of beams blocked in Zone 4 (e.g., for object detection)
53	User defined 1	User defined 1
54	User defined 2	User defined 2
55	User defined 3	User defined 3
56	User defined 4	User defined 4

Operator

0 equates to =

1 equates to ≥

2 equates to ≤

3 equates to ≠

Operand 2

0 ... 510

7.7.3.5 Energy saving mode*Table 112: Energy saving mode*

Object	Access	Data type	Description
2264h	R/W	BOOL	You use this object to activate standby mode. 0 = standby not active 1 = standby active

In order to reduce energy consumption, the MLG-2 can be set to standby mode.

Standby mode freezes the status of the outputs, i.e., they do not change their status even when objects enter or leave the detection area.

7.7.3.6 Switch-off delay

You can use the switch-off delay to adjust the output from the switching outputs so that it matches the installed PLC. You can set one individual switch-off delay each for switching outputs Q1 through Q4, and one shared switch-off delay for switching outputs Q5 through Q16.

The delays set here will also affect the bits in the “QS- Switching output status” process data.

Table 113: Switch-off delay

Object	Subindex	Access	Data type	Description
2265h	01h	R/W	UINT-16	This subindex is used to set a delay for switching output Q1.
	02h	R/W	UINT-16	This subindex is used to set a delay for switching output Q2.
	03h	R/W	UINT-16	This subindex is used to set a delay for switching output Q3.
	04h	R/W	UINT-16	This subindex is used to set a delay for switching output Q4.
	05h	R/W	UINT-16	This subindex is used to set a shared delay for switching outputs Q5 through Q16.

7.7.4 Objects with auxiliary resources and diagnostic options**7.7.4.1 Alignment aid***Table 114: Alignment aid*

Object	Access	Data type	Description
2270h	R/W	BOOL	You use this object to activate the alignment aid for the MLG-2. 0 = alignment aid not active 1 = alignment aid active

7.7.4.2 Values for alignment aid

Table 115: Values for alignment aid

Object	Access	Data type	Description
2271h	R	UINT-8	You use this object to read the values for certain beams on the MLG-2. Subindex 01h contains the value for the beam on the connection side. Subindex 02h contains the value for the beam on the end cap. Subindex 03h contains the value for the beam most heavily contaminated.

100% signal strength equates to value 100d

0% signal strength equates to value 0d

7.7.4.3 “Find Me” function

Table 116: “Find Me” function

Object	Access	Data type	Description
2272h	R/W	ENUM8	You use this object to activate the “Find Me” function on the MLG-2. 0 = function not active 1 = function active

The three LEDs on the front of the receiver flash when the “Find Me” function is activated.

If multiple MLG-2s are installed in one application, you can use the “Find Me” function to identify a certain MLG-2.

7.7.4.4 Pushbutton lock

Table 117: Pushbutton lock

Object	Access	Data type	Description
2273h	R/W	BOOL	You use this object to activate the pushbutton lock for the “Teach” pushbutton on the receiver of the MLG-2. 0 = pushbutton released 1 = pushbutton locked

7.7.4.5 Beam numbering

Table 118: Beam numbering

Index	Access	Data type	Description
2274h	R/W	BOOL	You use this object to reverse the beam numbering. 0 = beam 1 begins at the connection 1 = beam 1 begins at the head

On delivery, beam 1 is located on the connection side of the MLG-2. You can choose to configure the MLG-2 so that the beam numbering begins at the top.

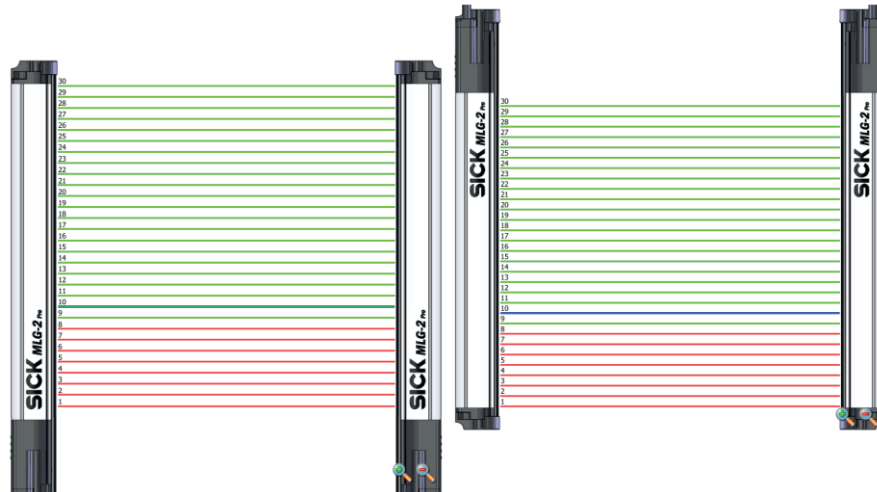

Figure 71: Beam numbering

This might be a good idea, for example, if you mount the MLG-2 with the connections facing upward, but still want to measure height classification from the bottom.



NOTE

Beam numbering has consequences for the beam functions FBB, FBM, LBB, LBM, CBB, CBM, RLC, and on the beam status.

7.7.4.6 Cloning upload

Table 119: Cloning upload

Index	Access	Data type	Description
2276h	R/W	BOOL	You use this object to save the parameters of the MLG-2 to the fieldbus module. 0 = parameters are not saved 1 = parameters are saved A change from 0 to 1 always initiates a save of the parameters to the fieldbus module. If the parameters are to be saved to the fieldbus module again, this object must first be described using 0.

The “Cloning upload” function writes the parameter set configured to the fieldbus module. Following device replacement, the parameters can be loaded back into the light grid from the fieldbus module using the “Cloning download” function.

7.7.4.7 Cloning download

Table 120: Cloning download

Object	Access	Data type	Description
2277h	R/W	BOOL	You use this object to load the parameters saved in the fieldbus module to the MLG-2. 0 = parameters are not loaded 1 = parameters are loaded A change from 0 to 1 always initiates a loading of the parameters into the MLG-2. If the parameters are to be loaded into the MLG-2 again, this object must first be described using 0.

**NOTE**

The MLG-2 restarts after the download. Existing bus connections or connections with SOPAS ET are interrupted briefly.

Any initial configurations for starting up the MLG-2 which have been set in the control overwrite the values that the cloning download has restored.

7.7.4.8 Cloning status

Table 121: Cloning status

Object	Access	Data type	Description
2278h	R	ENUM8	You use this object to read the status of the "Cloning" function. 0 = LOCKED 1 = EMPTY 2 = VALID 3 = ACTIVE

The cloning status shows the status of the stored parameters in the fieldbus module

- LOCKED: Uploading and downloading not possible.
- EMPTY: No valid set of parameters available.
Uploading parameters is the only option.
- VALID: A valid set of parameters is available in the fieldbus module.
Parameters can be uploaded or downloaded.
- ACTIVE: An upload or download is currently active.

7.7.5 Objects with system information**7.7.5.1 Device name**

Table 122: Device name

Object	Access	Data type	Description
2280h	R	STRG (18)	This object contains the type code (e.g., MLG10N-0140E10501).

7.7.5.2 Manufacturer name

Table 123: Manufacturer name

Object	Access	Data type	Description
2281h	R	STRG (32)	This object contains the manufacturer's name, SICK AG.

7.7.5.3 Part number

Table 124: Part number

Object	Access	Data type	Description
2282h	R	STRG (7)	This object contains the MLG-2's part number.

7.7.5.4 Serial number

Table 125: Serial number

Object	Access	Data type	Description
2283h	R	STRG (8)	This object contains the MLG-2's serial number.

7.7.5.5 Product text

Table 126: Product text

Object	Access	Data type	Description
2284h	R	STRG (64)	This object contains a brief description of the MLG-2 ProNet.

7.7.5.6 Mounting location

Table 127: Mounting location

Object	Access	Data type	Description
2285h	R/W	STRG (32)	You can save the mounting location of the MLG-2 in this object.

Entering a mounting location makes it easier to identify where the MLG-2 is mounted.

7.7.5.7 Device characteristics and system boundaries

Table 128: Device characteristics

Object	Sub-index	Access	Data type	Description
2286h		R	STRUCT	You use the subindexes of this object to read the device characteristics.
	01h	R	UINT-16	Reads the number of beams.
	02h	R	UINT-16	Reads the beam separation.
	03h	R	UINT-16	Reads the repeatability.
	04h	R	UINT-16	Reads the minimum presence time.
	05h	R	UINT-16	Reads the response time.

- The **beam number** reflects the number of beams from the MLG-2. Depending on the model, the MLG-2 can have between 6 and 510 beams, only 250 beams for the DPV0.
- **Beam separation:** In order to achieve different levels of measurement accuracy, the MLG-2 is available with different beam separations. (see "[Beam separations and monitoring height](#)", page 16).
- The repeat accuracy of a measurement result (**reproducibility**) is the amount of time by which an object detection can differ from a previous or subsequent detection. The reproducibility time is $1 \times$ the scan time. (see "[Scan time](#)", page 18). The reproducibility is output as an integer in μ s.
- The **minimum presence time** is the amount of time an object or gap must be in the detection area in order to be detected. The minimum presence time is no more than $2 \times$ the scan time (see "[Scan time](#)", page 18). The minimum presence time is output as an integer in μ s.
- The **response time** is the time it takes for an output to react following the detection of an object/gap. The maximum response time is $3 \times$ the scan time plus the transmission time to the outputs (see "[Scan time](#)", page 18). The response time is output as an integer in μ s.

7.7.5.8 Hardware revision

Table 129: Hardware revision

Object	Access	Data type	Description
2287h	R	STRG (4)	This object contains the revision status of the hardware.

7.7.5.9 Firmware version

Table 130: Firmware version

Object	Access	Data type	Description
2288h	R	STRG (12)	This object contains the version of the firm-ware.

The version of firmware in its delivery state can be found on the type label.

7.7.6 Objects with beam evaluation

7.7.6.1 Zone measuring

The beams of the MLG-2 can be divided into four zones. Each zone can be assigned one beam function or application. Zones and beam functions are assigned using the outputs. The functions NBB Zone n, LBB Zone n, FBB Zone n, CBB Zone n and NCBB Zone n are available for each zone (n = 1, 2, 3 or 4).

For additional information, see ["Zone measuring" function](#), page 135

Table 131: Zone measuring

Object	Subin- dex	Access	Data type	Description
2290h	01h	R/W	UINT-16	Zone 1 First Beam: Sets lower zone boundary for Zone 1
	02h	R/W	UINT-16	Zone 1 Last Beam: Sets upper zone boundary for Zone 1
	03h	R/W	UINT-16	Zone 2 First Beam: Sets lower zone boundary for Zone 2
	04h	R/W	UINT-16	Zone 2 Last Beam: Sets upper zone boundary for Zone 2
	05h	R/W	UINT-16	Zone 3 First Beam: Sets lower zone boundary for Zone 3
	06h	R/W	UINT-16	Zone 3 Last Beam: Sets upper zone boundary for Zone 3
	07h	R/W	UINT-16	Zone 4 First Beam: Sets lower zone boundary for Zone 4
	08h	R/W	UINT-16	Zone 4 Last Beam: Sets upper zone boundary for Zone 4

7.7.6.2 Cross beam measuring

For the "Performance options" object, see ["Performance options"](#), page 93

Table 132: Cross beam measuring

Object	Access	Data type	Description
2298h	R/W	BOOL	If the "Cross beam function" option is activated via the "2261h performance options" object, you can use this object to choose between the "Cross beam measuring" and "Cross beam switching" options. 0 = "Cross beam measuring" function deactivated. "Cross beam switching" function is active. 1 = "Cross beam measuring" function activated.

7.7.6.3 BBH and LBH evaluation modes

For a description of the “Blocked Beams Hold (BBH)” evaluation mode, see [“Blocked Beams Hold \(BBH\)” evaluation mode](#), page 146

For a description of the “Lost Beams Hold (LBH)” evaluation mode, see [“Lost Beams Hold \(LBH\)” evaluation mode](#), page 147

Table 133: Evaluation mode

Object	Subindex	Access	Data type	Description
2299h		R/W	ENUM-8	This parameter is used to select an evaluation mode. 0: OFF, no BBH mode or LBH mode active 1: BBH mode active 2: LBH mode active
229Ah		R/W	STRUCT	This parameter is used to activate and deactivate the beam functions that will be used for the evaluation mode.
	01h	R/W	UINT-8	Byte 0: NBB
	02h	R/W	UINT-8	Byte 1: NBM
	03h	R/W	UINT-8	Byte 2: FBB
	04h	R/W	UINT-8	Byte 3: FBM
	05h	R/W	UINT-8	Byte 4: LBB
	06h	R/W	UINT-8	Byte 5: LBM
	07h	R/W	UINT-8	Byte 6: NCBB/CBB
	08h	R/W	UINT-8	Byte 7: NCBM/CBM
	09h	R/W	UINT-8	Byte 8: ODI
	0Ah	R/W	UINT-8	Byte 9: IDI
	0Bh	R/W	UINT-8	Byte 10: RLC
	0Ch	R/W	UINT-8	Byte 11: BS
	0Dh	R/W	UINT-8	Byte 12: NBB Zone 1
	0Eh	R/W	UINT-8	Byte 13: NBB Zone 2
	0Fh	R/W	UINT-8	Byte 14: NBB Zone 3
	10h	R/W	UINT-8	Byte 15: NBB Zone 4
	11h	R/W	UINT-8	Byte 16: FBB Zone 1
	12h	R/W	UINT-8	Byte 17: FBB Zone 2
	13h	R/W	UINT-8	Byte 18: FBB Zone 3
	14h	R/W	UINT-8	Byte 19: FBB Zone 4
	15h	R/W	UINT-8	Byte 20: LBB Zone 1
	16h	R/W	UINT-8	Byte 21: LBB Zone 2
	17h	R/W	UINT-8	Byte 22: LBB Zone 3
	18h	R/W	UINT-8	Byte 23: LBB Zone 4
	19h	R/W	UINT-8	Byte 24: NCBB/CBB Zone 1
	1Ah	R/W	UINT-8	Byte 25: NCBB/CBB Zone 2
	1Bh	R/W	UINT-8	Byte 26: NCBB/CBB Zone 3
1Ch	R/W	UINT-8	Byte 27: NCBB/CBB Zone 4	

7.7.7 Objects for initiating operating functions

7.7.7.1 Control

This object can be transferred in the RPDO. Acyclic write access can be cyclically overwritten.

Table 134: Control

Object	Access	Data type	Description
2214h	R/W	UINT-8	This object is used to initiate operating functions on the MLG-2.

The object's individual functions are stored in 8-bit:

Table 135: Details

Bit 7	TEST – Sender dark switching <ul style="list-style-type: none"> 0 = normal light grid function 1 = TEST active, i.e. the sender is switched off
Bit 6	LEARN – Sensitivity teach-in <ul style="list-style-type: none"> 0 = one-time sensitivity teach-in not active 1 = one-time sensitivity teach-in active
Bit 5	BBH – Blocked Beams Hold (saves blocked beams) <ul style="list-style-type: none"> 0 = Blocked Beams Hold deactivated 1 = Blocked Beams Hold activated
Bit 4	Reserved
Bit 3	Reserved
Bit 2	SB – Standby (The sender is switched off. The beam status, basic functions and switching output are maintained. These are invalid, since the light grid does not perform measurements.) <ul style="list-style-type: none"> 0 = standby deactivated 1 = standby activated
Bit 1	Reserved
Bit 0	Reserved

7.7.8 Compatibility objects



NOTE

The compatibility objects are only used for replacing predecessor version MLG for an MLG-2. Do not use these objects to implement new applications with the MLG-2.

7.7.8.1 Beam status with 8-bit length

The beam statuses with 8-bit length are output with the subindexes of the 2300h object.



NOTE

The beam statuses of a maximum of 240 beams are output with object 2300h.

Table 136: Beam status with 8-bit length

Object	Subindex	Access	Data type	Description
2300h		R	UINT-8	You use the subindexes of this object to read the MLG-2's beam status in 8 bit.
	01h	R		Subindex 01h contains beams 1 to 8.
	02h	R		Subindex 02h contains beams 9 to 16.
	...	R		...
	1Eh	R		Subindex 1Eh contains beams 233 to 240.

7.7.8.2 Beam functions with 8-bit length

The beam functions with 8-bit length are output with the subindexes of the 2306h object.

Table 137: Beam functions with 8-bit length

Object	Access	Data type	Description
2306h	R	RECORD 16 × UINT-8	You use this object to read the predefined beam functions from the MLG-2.

8 Bit – NBB (Number of Beams Blocked)

Table 138: NBB with 8-bit length

Subindex	Access	Data type	Description
01h	R	UINT-8	The subindex contains the number of blocked beams.

8 Bit – NBM (Number of Beams Made)

Table 139: NBM with 8-bit length

Subindex	Access	Data type	Description
02h	R	UINT-8	The subindex contains the number of beams made.

8 Bit – FBB (First Beam Blocked)

Table 140: FBB with 8-bit length

Subindex	Access	Data type	Description
03h	R	UINT-8	The subindex contains the number of the first beam blocked.

8 Bit – FBM (First Beam Made)

Table 141: FBM with 8-bit length

Subindex	Access	Data type	Description
04h	R	UINT-8	The subindex contains the number of the first beam made.

8 Bit – LBB (Last Beam Blocked)

Table 142: LBB with 8-bit length

Subindex	Access	Data type	Description
05h	R	UINT-8	The subindex contains the number of the last beam blocked.

8 Bit – LBM (Last Beam Made)

Table 143: LBM with 8-bit length

Subindex	Access	Data type	Description
06h	R	UINT-8	The subindex contains the number of the last beam made.

8 Bit – NCBB (Number of Consecutive Beams Blocked)

Table 144: NCBB with 8-bit length

Subindex	Access	Data type	Description
07h	R	UINT-8	The subindex contains the total number of consecutive beams blocked.

8 Bit – NCBM (Number of Consecutive Beams Made)

Table 145: NCBM with 8-bit length

Subindex	Access	Data type	Description
08h	R	UINT-8	The subindex contains the total number of consecutive beams made.

8 Bit – CBB (Central Beam Blocked)

Table 146: CBB with 8-bit length

Subindex	Access	Data type	Description
09h	R	UINT-8	The subindex contains the beam number of the central beam blocked.

8 Bit – CBM (Central Beam Made)

Table 147: CBM with 8-bit length

Subindex	Access	Data type	Description
0Ah	R	UINT-8	The subindex contains the beam number of the central beam made.

8 Bit – ODI (Outside Dimension)

Table 148: ODI with 8-bit length

Subindex	Access	Data type	Description
0Bh	R	UINT-8	The subindex contains an object's outside dimension.

8 Bit – IDI (Inside Dimension)

Table 149: IDI with 8-bit length

Subindex	Access	Data type	Description
0Ch	R	UINT-8	The subindex contains an object's inside dimension.

7.7.8.3 System status with 8-bit length

Table 150: System status with 8-bit length

Object	Access	Data type	Description
2308h	R	UINT-8	You use this object to read the system status.

The system status is stored in 8 bit:

Table 151: Details of the system status with 8-bit length

Bit 7	Bit 6	Bit 5	Bit 4	Bit 3	Bit 2	Bit 1	Bit 0
Synchronization error	Teach-in error	Hardware error	Contamination	Teach-in active	Overtemperature	Process data invalid	Short-circuit at switching output

7.7.8.4 Status of the switching output and the virtual switching outputs with 8-bit length

Table 152: Status of the switching output and the virtual switching outputs with 8-bit length

Object	Access	Data type	Description
2310h	R	UINT-8	You use this object to read the status of the switching output Q1 and the status of the virtual switching outputs Q2 to Q8. Bit 0 = Q1 (physical output) Bit 1 ... 8 = Q2 ... Q8 (virtual outputs) 0 = output not active 1 = output active

8 Configuration with SOPAS ET

8.1 Preparation

8.1.1 Installing the software

SOPAS ET 3.0 or higher is required for configuring the MLG-2.

The latest version of SOPAS ET can be found at www.sick.de > Search > SOPAS.

Observe the system requirements for SOPAS ET. These are mentioned on the download website:

- ▶ Run the setup.exe from the download website.
- ▶ Follow the instructions in the Setup wizard.

Ethernet settings

The MLG-2 is shipped with the following IP network configuration:

- Static IP address. DHCP deactivated.
- IP address: 192.168.200.100
- Subnet mask: 255.255.255.0

You can change the IP network configuration in SOPAS ET.

If you would like the MLG-2 to acquire an IP address from a DHCP server, DHCP must be activated. If the MLG-2 is unable to locate a DHCP server, the MLG-2 will use the IP address 192.168.200.100.

Starting the software

Use the application **SICK > SOPAS Engineering Tool > Sopas** from the Start menu to configure the MLG-2.

8.1.2 Device selection

A SOPAS Device Description (SDD) is required in order to configure the MLG-2.

Detecting a connected device

When an MLG-2 is connected to the PC/notebook via Ethernet, the SDD can be loaded directly from the device and SOPAS ET will detect the MLG-2 type automatically.

Configuring a device offline

Alternatively, you can select the MLG-2 type offline using the device selection wizard. To do this, you must load the SDD from the Internet. This requires an Internet connection.

You can either enter the type code of the MLG-2 directly into the device selection wizard or define the following criteria:

- Monitoring height
- Maximum sensing range
- Interface (number and type of inputs and outputs)
- Size of the smallest object in the application

Once you have selected the desired MLG-2, the configuration interface/wizard starts up.



NOTE

If you configure a device offline, you must then connect the PC to the MLG-2 and download the MLG-2 configuration.

8.2 SOPAS ET interface

At the top of the interface, you can change the MLG-2 type, the operating mode, and the user level.

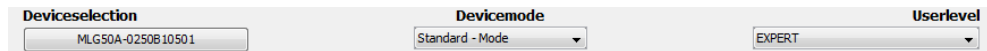

Figure 72: Device selection, operating mode and user level

Device selection

If you carry out the configuration offline (without a connected MLG-2), you can change the MLG-2 type via the button shown on the left.

If the MLG-2 is online, the type code of the MLG-2 will be displayed.

Operating modes

The MLG-2 has the following operating modes:

- Standard
For normal measuring tasks involving opaque objects (recommended for the majority of applications)
- Transparent
For transparent objects, e.g., made of glass, PET, etc.
- Dust- and sunlight-resistant
For applications when there is a large amount of dust in the environment or a high level of solar radiation



NOTE

When the operating mode is changed, a new teach-in process must be performed.

The choice of operating mode affects the performance options.

User level

The configuration is divided into two user levels.

The user level **EASY** shows only the parameters that are absolutely necessary and is a quick way of completing the task. This level is automatically activated when SOPAS ET starts up.

For experienced users or those with more complex requirements, the user level **EXPERT** allows you to configure all of the parameters.

Three-part interface

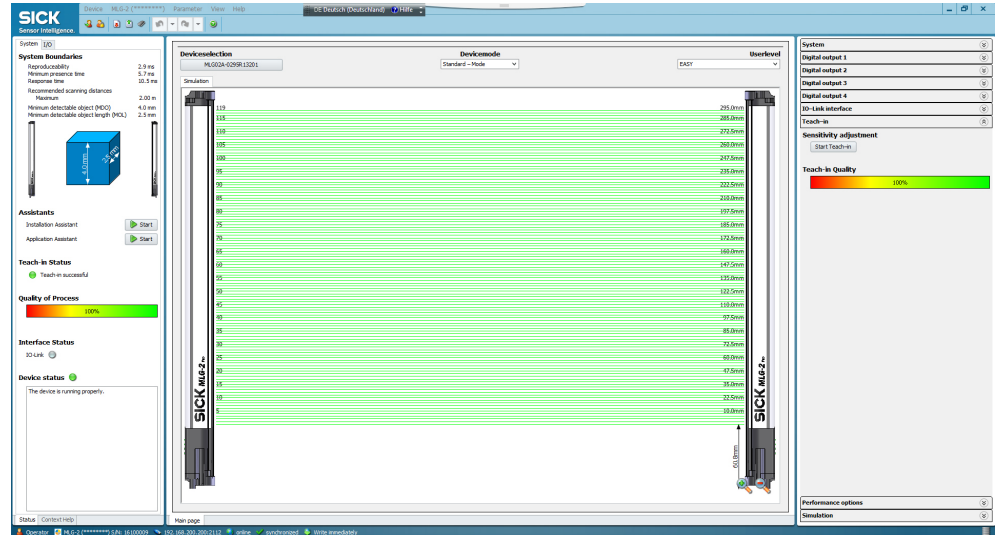

Figure 73: SOPAS ET interface

The **left-hand side** of the graphical interface provides information on the system boundaries, the status and the interfaces of the connected MLG-2.

The **central area** shows a simulation of the light grid and its beams.

The **right-hand side** of the interface lists the available options in expandable menus.

8.2.1 System boundaries and status

System boundaries

System boundaries

Reproduceability	0.7 ms
Minimum presence time	1.4 ms
Response time	3.6 ms
Max. recommended scanning distance	5.0 m
Minimum detectable object (MDO)	14 mm
Minimum detectable object length (MOL)	7 mm

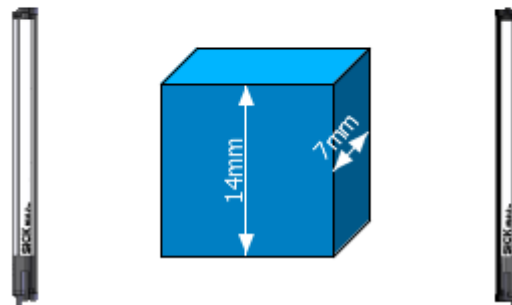

Figure 74: Display of the system boundaries

Under “System boundaries”, SOPAS ET displays the reproducibility, minimum presence time, and response time (see "Scan time", page 18).

SOPAS ET displays the maximum recommended sensing range with which the MLG-2 can be safely operated.

The minimum detectable object (MDO) and the minimum detectable object length (MOL) are specified in millimeters as well as shown graphically.

The system boundaries are largely dependent on the configured performance options (see "Performance options", page 140).

Wizards

Wizards



Figure 75: Wizards

You can start the Installation Wizard or Application Wizard under **Wizards**.

- The **Installation Wizard** helps you to align the MLG-2 and carry out the teach-in process.
- The **Application Wizard** helps you to configure the settings for the outputs. Only the necessary adjustments for the MLG-2 are offered, according to the choice of application.

Recommendation

Use this wizard for the initial configuration of a device. The separate adjustments available in the main interface allow the user to make specific changes to the configuration.

Teach-in status

If a teach-in becomes necessary because of a change to a parameter, the LED symbol will light red, indicating **teach-in required**.

Process quality

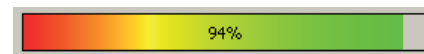

Figure 76: Display of the process quality

SOPAS ET shows the process quality as a percentage and as a colored bar.

Interface status

SOPAS ET displays the communication status via the respective interface.

- Green = communication active
- Gray = communication not active

Device status

SOPAS ET displays the device status via a colored indicator and in the form of plain text:

- Green = MLG-2 functions reliably
- Yellow = warning pending
- Red = error has occurred

8.2.2 Basic functions and status of the output

Basic functions

Under **Basic functions**, you will find the following information:

- The current values for the beam functions (see "Beam functions", page 153)
- The current values for the run-length code

System
I/O

Basic Functions

NBB = 0 (Number of Beams Blocked)
 NBM = 60 (Number of Beams Made)
 FBB = n° - (First Beam Blocked)
 FBM = n° 1 (First Beam Made)
 LBB = - (Last Beam Blocked)
 LBM = 60 (Last Beam Made)
 NCBB = 0 (Number of consecutive Beams Blocked)
 NCBM = 60 (Number of consecutive Beams Made)
 CBB = n° - (Central Beam Blocked)
 CBM = n° 30 (Central Beam Made)
 ODI = 0 (Outside Dimension)
 IDI = 0 (Inside Dimension)

RLC-Values (Run Length Code)

RLC1	RLC2	RLC3	RLC4	RLC5	RLC6	RLC7	RLC8
60	0	0	0	0	0	0	0
RLC9	RLC10	RLC11	RLC12	RLC13	RLC14	RLC15	RLC16
0	0	0	0	0	0	0	0

Status In-/Outputs

Q1 NBB ≥ 1

Figure 77: Basic functions and status of the output

Status inputs/outputs

Under Status inputs/outputs, SOPAS ET shows the status of the switching output. Next to the indicator, you will find the function configured for the output.

8.2.3 Representation of the detection area

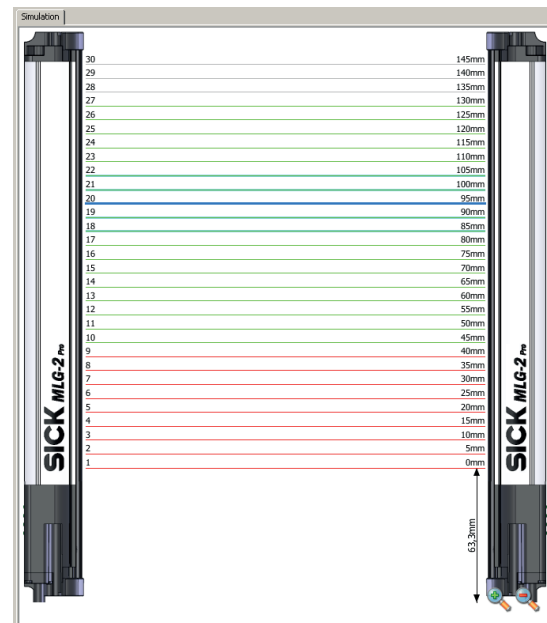

Figure 78: Detection area – Simulation

The **central** area of the SOPAS ET interface shows a simulation of the MLG-2 and its beams:

- Green = Made beams
- Red = Blocked beams
- Gray = Blanked beams
- Blue = Beams selected with the mouse
- Turquoise = Configured tolerance

You can use the context menu to perform certain actions with the selected beams.

Context menu – Combining beams into zones

- ▶ Select multiple consecutive beams.
- ▶ In the context menu, select the command **Combine to a zone > Zone X**.

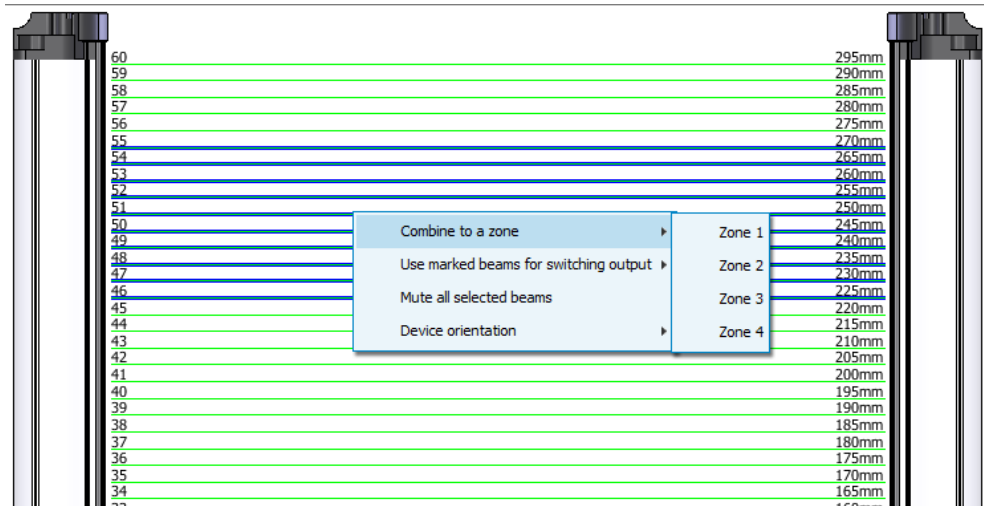

Figure 79: Combining beams into zones

First, configure a zone in the beam window. In the example, beams 13 and 14 are combined into one zone. Next, assign an application and a zone to the desired output (see ["Zone measuring" function](#), page 135).

Context menu – Using beams for object recognition

- ▶ Select several beams (by pressing the Ctrl key).
- ▶ In the context menu, select the command **Assign selected beams to a switching output > For object recognition > Use Qx**.

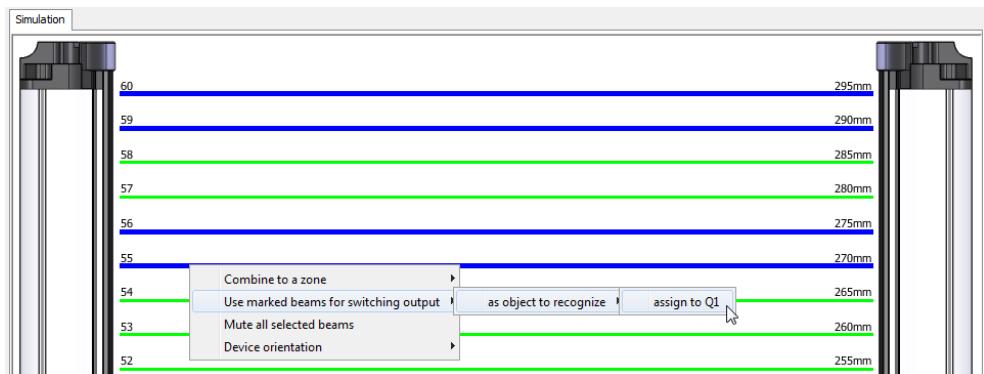

Figure 80: Using beams for object recognition

In the example, beams 10 and 11 and beams 14 and 15 are assigned to output Q1. If these beams are blocked, output Q1 switches. The object size may vary positively or negatively by the number of tolerance beams set (see "Object recognition", page 123).

Context menu – Using beams for height classification

- ▶ Select a beam.
- ▶ In the context menu, select the command **Assign selected beams to a switching output > As maximum height > Use Qx.**

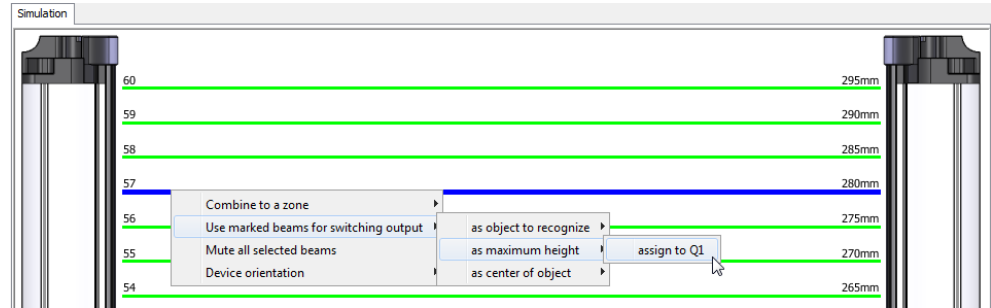

Figure 81: Using beams for height classification

In the example, beam 12 is assigned to output Q1. If the last beam blocked is greater than or equal to beam 12, output Q1 switches.

Context menu – Using beams to classify the object position

- ▶ Select a beam.
- ▶ In the context menu, select the command **Assign selected beams to a switching output > As center of object > Use Qx.**

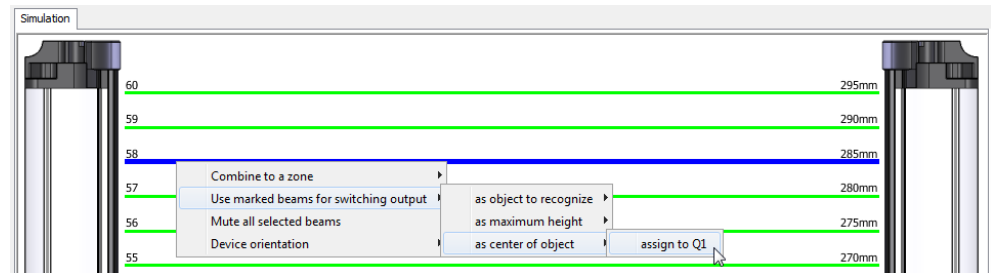

Figure 82: Using beams to classify the object position

In the example, beam 13 is assigned to output Q1. If beam 13 is detected as the center of the object (e.g., beams 12, 13, 14 or beams 11, 12, 13, 14, 15 are blocked), output Q1 switches.

Context menu – Blanking beams

- ▶ Select one or more beams (press the Ctrl key to select several beams).
- ▶ In the context menu, select the command **Blank all selected beams.**

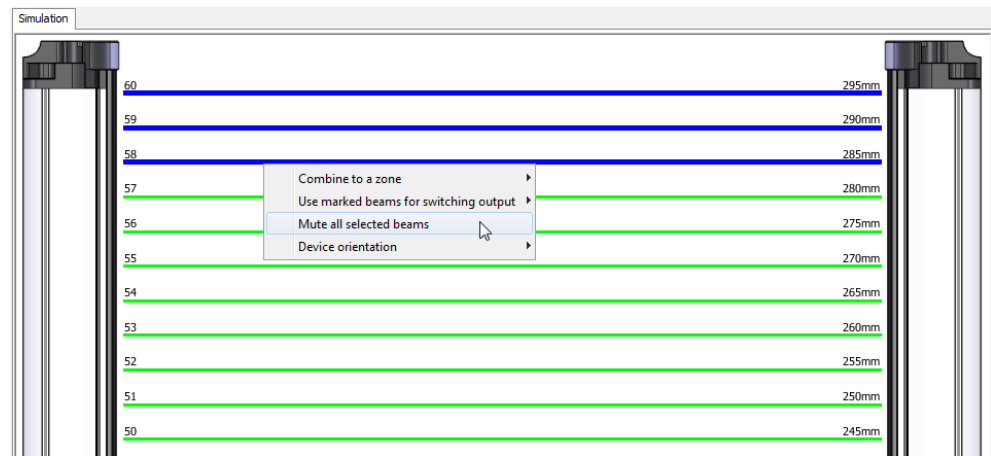

Figure 83: Blanking beams

In the example, beams 13, 14, and 15 are selected and blanked. They are shown in gray and excluded from the measurement.

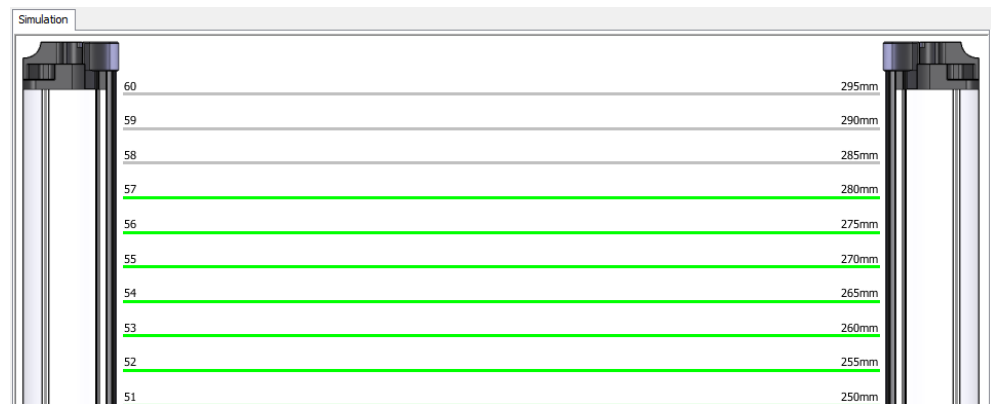

Figure 84: Blanked beams

Context menu - Rotating the image of the MLG-2

The image of the MLG-2 can be adapted for particular applications.

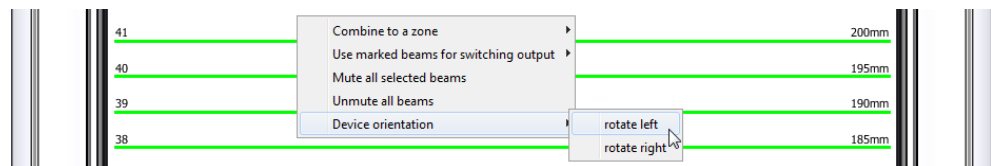

Figure 85: Rotating the image of the MLG-2

- In the context menu, select the command **Device orientation** > **rotate left** or > **rotate right**.

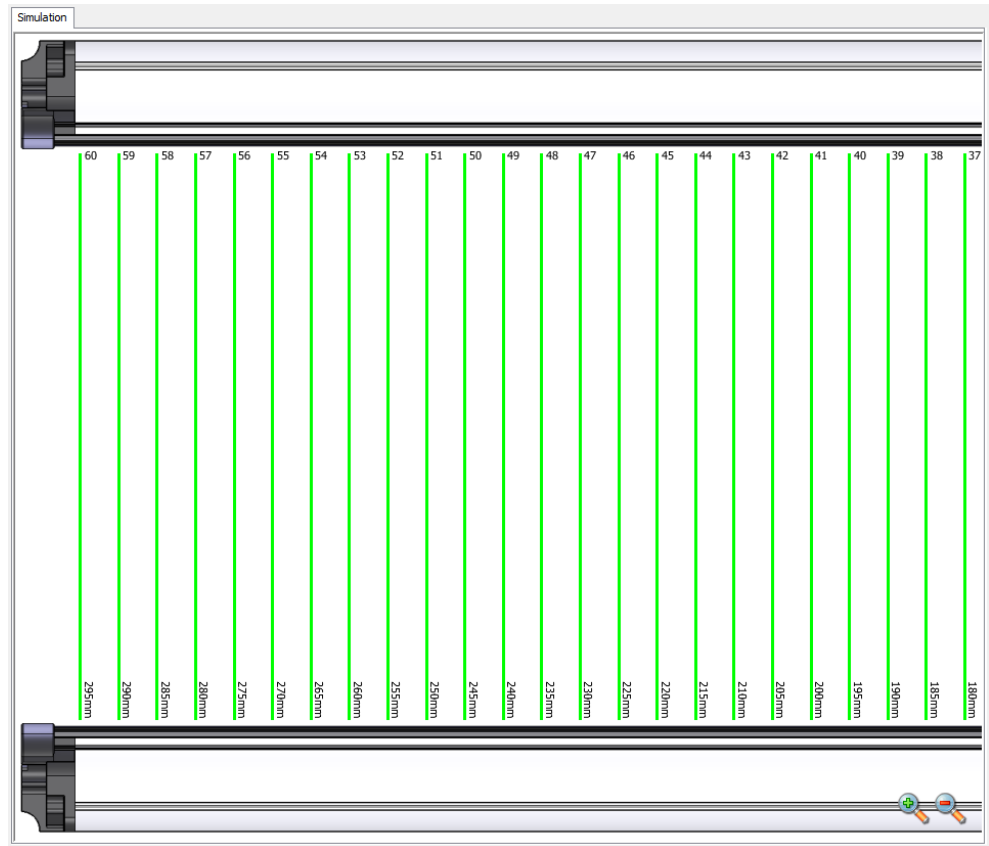

Figure 86: Image of the MLG-2 rotated

Repeat this process until you are happy with how the image appears.

8.2.4 Expandable menus

The expandable menus on the right-hand side help you to configure the MLG-2.



Figure 87: Expandable menus for configuration

- ▶ Click on the double arrow to open the expandable menu.
- ▶ To close the expandable menu, click the double arrow – which is now inverted – again.

Configuring the outputs

When the MLG-2 is online, the configuration of the outputs is written to the device and transferred immediately to the status indicator for the outputs. You will see the response of the outputs immediately in the status indicator.

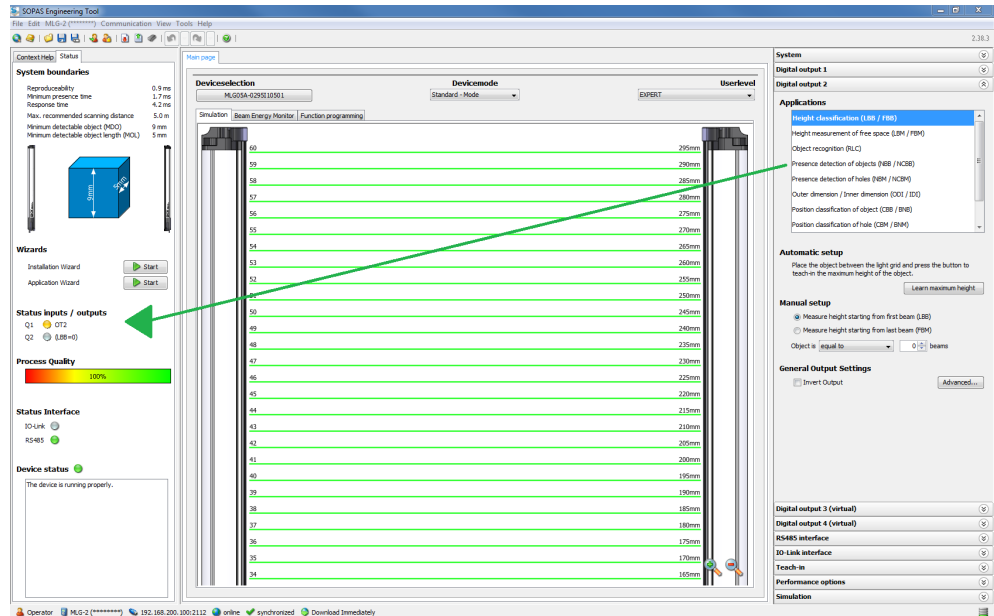

Figure 88: Effect of the output configuration on the status indicator

Configuring the performance options

When the MLG-2 is online, the performance options are written to the device and displayed immediately in the system boundaries (it may be necessary to perform a teach-in process after changing the performance options).

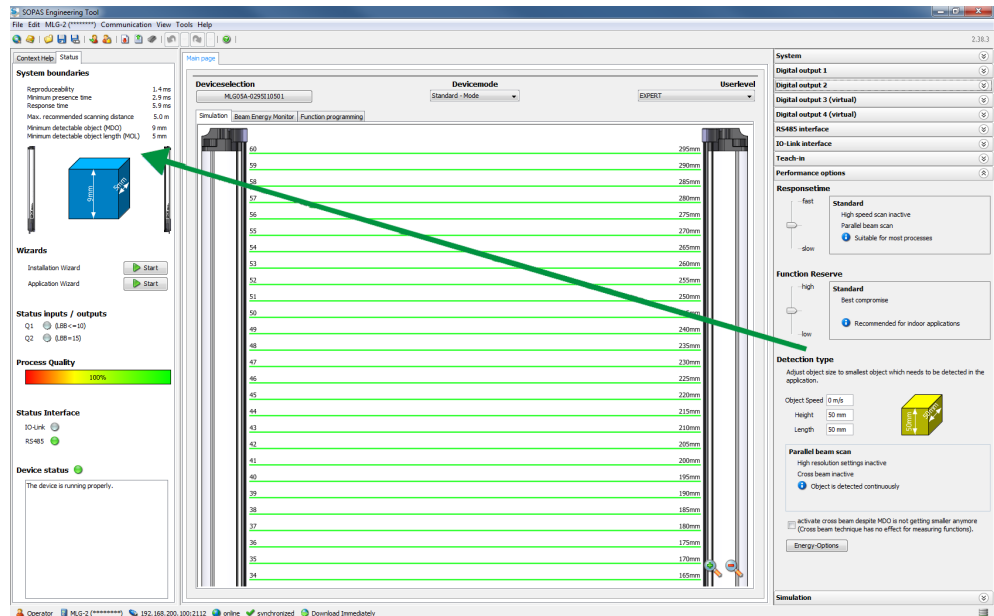

Figure 89: Effects of the performance options on the system boundaries

8.3 System settings

8.3.1 System settings for the user levels EASY and EXPERT

Identification

The **Identification** area contains the following information:

- Type code
- Optional: Current type code
This field is only displayed when the current system constellation is different from the original one delivered.
The MLG-2 consists of a receiver, fieldbus module and sender. These components are defined by the type code in the receiver. If a different field bus module or/and another sender is being used, the type code resulting from this is shown as the **current type code**.
- Part number
- Manufacturer
- Serial number
- Individual device name
You can enter a description of the MLG-2's application or usage here.

Version

The **Version** area contains the following information:

- Hardware version
- Software version
- Fieldbus module hardware version
- Fieldbus module software version

Pushbutton lock

You can use the pushbutton lock to set two options for the teach-in button on the device:

- Released: A teach-in process can be triggered using the button.
- Locked: The teach-in button is locked to prevent inadvertent actuation, for example.

8.3.2 System settings for the EXPERT user level

I/O configuration

I/O configuration		
I/O No.	Pin No.	Pin configuration
1	4	OUTPUT
2	6	INPUT

Figure 90: I/O configuration

You can view the MLG-2's output and the pin on the connection in this figure.

Beam numbering

On delivery, beam 1 is located on the connection side of the MLG-2. You can choose to configure the MLG-2 so that the beam numbering begins at the top.

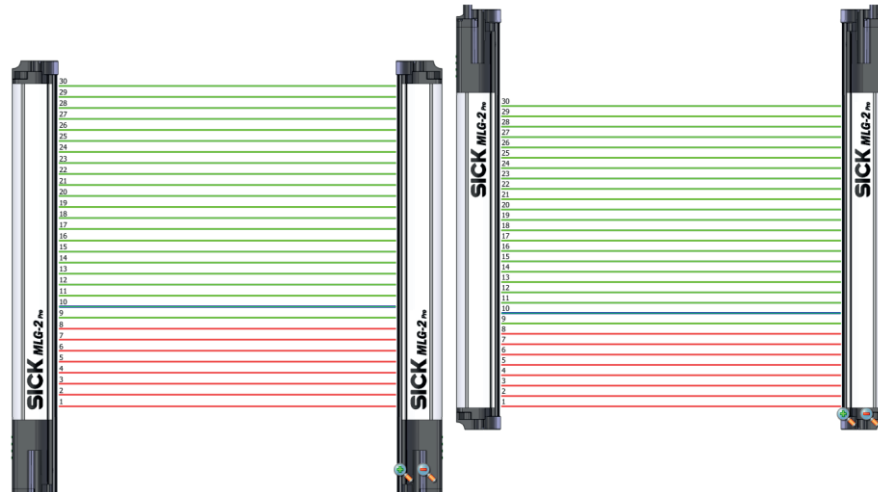

Figure 91: Beam numbering

This might be a good idea, for example, if you mount the MLG-2 with the connections facing upward, but still want to measure height classification from the bottom.



NOTE

Beam numbering has consequences for the beam functions FBB, FBM, LBB, LBM, CBB, CBM, RLC, and on the beam status.



NOTE

This affects measuring functions that have already been configured. In the example, a height classification is configured with the 10th beam (blue).

Pushbutton lock

You can use the pushbutton lock to set two options for the teach-in button on the device:

- Released: A teach-in process can be triggered using the button.
- Locked: The teach-in button is locked to prevent inadvertent actuation, for example.

Reset

You have the option to reset the MLG-2 to the factory settings.

If you reset to factory settings, you will lose all data that has already been configured.



NOTE

- The factory settings are restored as soon as 1 is written.
- The MLG-2 will be reset too. Therefore, the control reports, where necessary, an error that the MLG-2 is no longer available.
- The following applies after resetting to factory settings:
 - No process data such as beam functions or beam status is output.
 - The alignment aid is active.
 - A teach-in is required. All functions become available again only after a successful teach-in process.

The **Reset** command sets the MLG-2 back to the **factory settings**.

Ethernet

In the **Ethernet** area, you make communication interface TCP/IP settings for SOPAS ET or the integrated web server.

First of all, select the **DHCP** or **Static** option from the **Addressing mode** field.

With the **Static** addressing mode, you can change the **IP address**, the **subnet mask**, and the **gateway address**. The **MAC address** is also displayed.



NOTE

Only make changes if you know your network very well and you know what effect the changes will have on the settings!

8.3.3 System settings for CANopen

In the **address configuration** area, you can enter the **address** in CAN and select the **baud rate**. You can enter address 1 to 127 for the MLG-2.

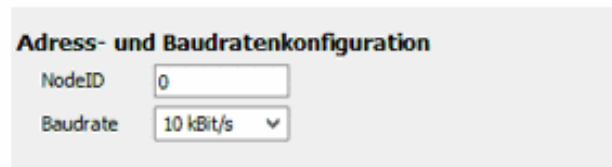

The screenshot shows a dialog box titled "Adress- und Baudratenkonfiguration". It contains two fields: "NodeID" with a text input field containing the number "0", and "Baudrate" with a dropdown menu currently showing "10 kBit/s".

Figure 92: Node ID and baud rate in SOPAS ET



NOTE

Only make changes if you know your network very well and you know what effect the changes will have on the settings!

8.4 Measuring and diagnostic functions for switching outputs

A measuring or diagnostic function can be configured for each switching output on the MLG2. If the criteria configured for the function are met, this is signaled on the relevant output.

All measuring functions can be configured manually. The configurable details are shown for the selected measuring function.

For the **height classification** and **object recognition** measuring functions, objects that are actually in the detection area can be defined automatically.

The measuring functions that have been set are shown graphically in the Simulation area and can be edited here using the mouse.

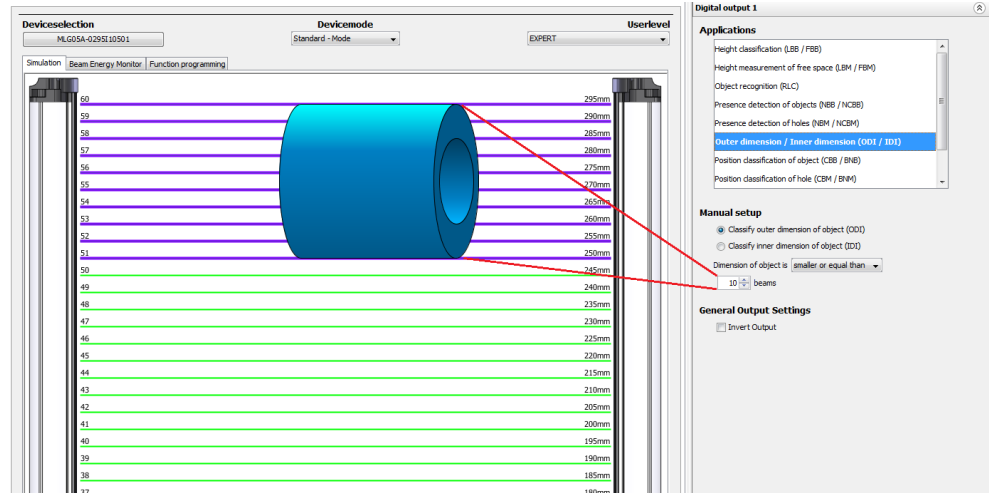

Figure 93: Example representation of the outer dimension

The results of the measuring functions are shown on the status display for the outputs (see "Basic functions and status of the output", page 111).



NOTE

The configuration of the switching outputs is linked to the function programming option (only visible in the **EXPERT** user level). Settings made when configuring the outputs are also shown in the function programming option. If very complex configurations are created for an output in the function programming option, these can no longer be changed in the configuration of the switching outputs.

8.4.1 Height classification

A switching output switches when the measured object corresponds to the configured or defined height.

Automatic configuration

SOPAS ET can teach in the maximum object height automatically.

The output becomes active when an object is larger than the defined object. The device checks, therefore, whether an object exceeds a certain height.

- ▶ Place or hang the object in the detection area of the MLG-2.
- ▶ Click **Teach-in maximum height**.
The measurement is taken from the top or bottom automatically, depending on the alignment of the object.
The algorithm first checks whether the first or last beam is blocked:
 - If the first beam is blocked, the height is measured from the bottom.⁶⁾
 - If the last beam is blocked, the height is measured from the top.⁶⁾
 If both the first and last beams are made or blocked, the optical center of gravity is determined.
 - If more beams are blocked on the side of the first beam, the height is measured from the bottom.
 - If more beams are blocked on the side of the last beam, the height is measured from the top.

⁶⁾ Applies when light grid is mounted upright with the connection side facing down and beam numbering beginning on the connection side (factory setting).



NOTE

Blocked beams are shown in the simulation in red and made beams are shown in green. The automatically defined object height can be further adjusted afterward.

Manual configuration

- ▶ Select the beam from which the height is to be measured:
 - Height measured from last beam
 - Height measured from first beam
- ▶ Select one of the following settings for the height classification and enter the number of beams n:

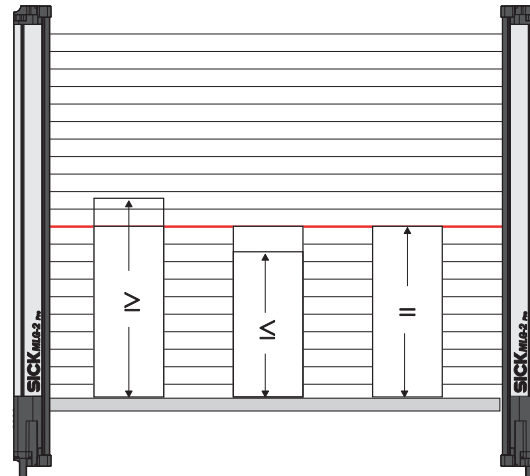

Figure 94: Settings for height classification

- **≥ Object is larger than or equal to n beams:**
The output becomes active when an object covers the beam defined as the top beam or reaches beyond this beam.
- **≤ Object is smaller than or equal to n beams:**
The output becomes active when an object covers the beam defined as the top beam or falls short of this beam.
- **= Object is equal to n beams:**
The output becomes active when an object is the exact same size as the beam defined as the top beam.

The beam that has been set is shown in blue in the **Simulation** area. It can be moved using the mouse.

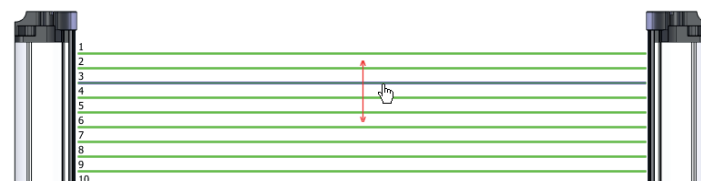

Figure 95: Setting the height with the mouse

Zone selection

For additional information, see "["Zone measuring" function](#)", page 135 .

Output settings

General options for switching outputs see "[Advanced settings for the outputs](#)", page 134.

8.4.2 Object recognition

The MLG-2 memorizes the pattern of configured or defined objects. The output switches when the MLG-2 recognizes objects or gaps with the configured size.



NOTE

The maximum number of beam status changes may not exceed the half number of beams, but at least 16 and a maximum of 120.

Defining an object automatically

You can define the object to be detected automatically.

- ▶ Place the object(s) in the detection area of the MLG-2.
- ▶ Then click **Teach-in object**.

The size of the objects and the size of the gaps between the objects are shown in the simulation. The sizes can be further adjusted afterward.

Manual configuration

In the simulation, you can determine the size of the object(s) by selecting corresponding beams.



Figure 96: Beams highlighted in color in the simulation

The blue beams in the Simulation area represent the object; the beams shown in turquoise are the tolerance.

Settings for automatic and manual configuration

- ▶ Select one of the following settings for object recognition:
 - **Static**
An object will be recognized if it is in the exact location in which the object was configured or automatically defined. This also applies to multiple objects, e.g., the feet of a pallet.

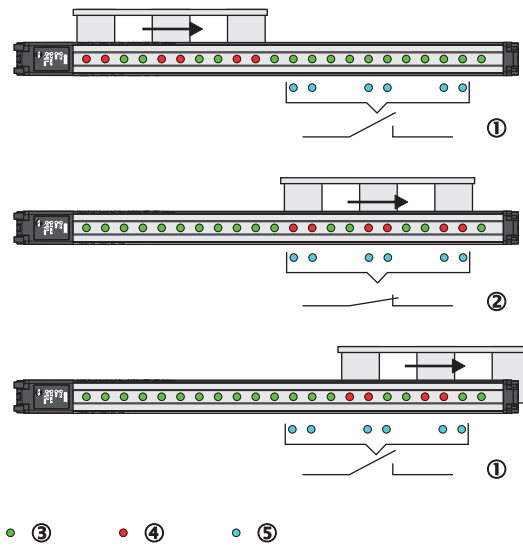

Figure 97: Object recognition, static

- ① Output not switched
- ② Output switched
- ③ Made beam
- ④ Blocked beam
- ⑤ Configured beam

• **Dynamic**

An object will be recognized at every point in the detection area. The object is allowed to move within the detection area. This also applies to multiple objects, e.g., the feet of a pallet.

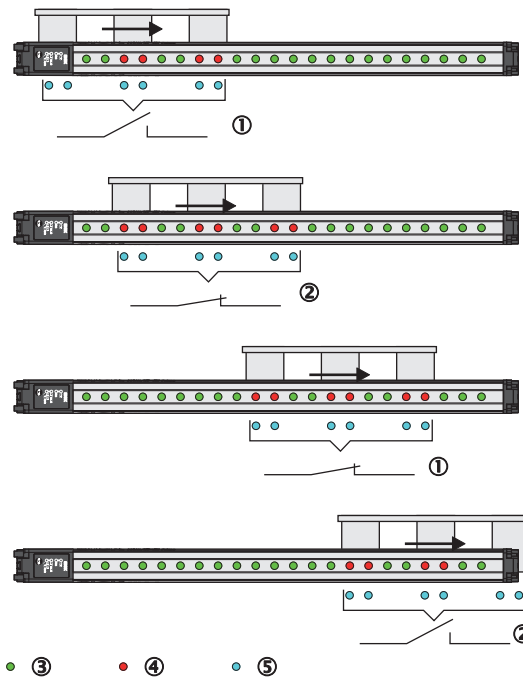

Figure 98: Object recognition, dynamic

- ① Output not switched
- ② Output switched
- ③ Made beam

- ④ Blocked beam
- ⑤ Configured beam

• **Tolerance**

Without a tolerance, objects will only be recognized if they block exactly the configured number of beams. If you enter a tolerance, the object size can vary positively or negatively by the number of tolerance beams.

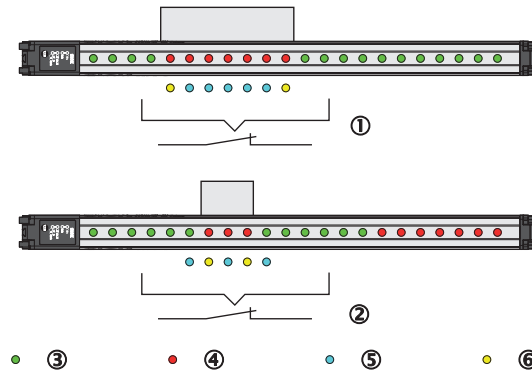

Figure 99: Object recognition with tolerance

- ① Positive tolerance
- ② Negative tolerance
- ③ Made beam
- ④ Blocked beam
- ⑤ Configured beam
- ⑥ Tolerated beams

When a tolerance is set, it is shown in the simulation with turquoise beams.

Output settings

General options for switching outputs see "[Advanced settings for the outputs](#)", page 134.

8.4.3 Object detection/object width

A switching output switches when an object of a particular size is present in the detection area.

A corresponding setting is configured which requires a certain number of beams or a certain number of **consecutive** beams to be blocked.

The number of beams is configured in the settings or configured graphically in the **Simulation** area using the mouse.

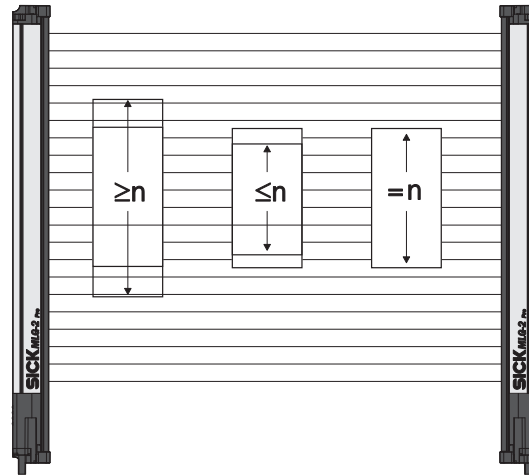

Figure 100: Object detection/object width

- ▶ Select one of the following n settings for the object detection/object width and enter the number of n beams:
 - **≥ n object is larger than or equal to n beams:**
The output becomes active when the configured number of beams or more has been blocked.
 - **≤ n object is smaller than or equal to n beams:**
The output becomes active when the configured number of beams or less has been blocked.
 - **= n object is equal to n beams:**
The output becomes active if the exact number of configured beams is blocked.

The object size that has been set is shown in the **Simulation** area. It can be changed using the mouse.

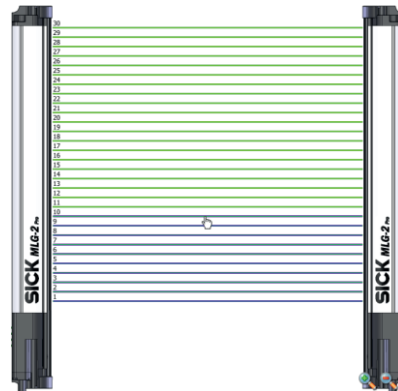

Figure 101: Setting the object size with the mouse

Only take into account consecutive beams:

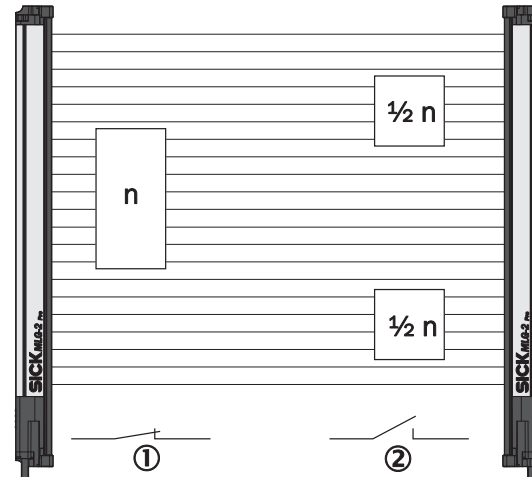

Figure 102: Object detection of consecutive objects

- ① Criterion met
- ② Criterion not met

The output becomes active when consecutive beams are covered. If this option is not activated, the number of blocked beams can also be made up of several objects or objects with gaps.

Zone selection

For additional information, see ["Zone measuring" function](#), page 135 .

Output settings

General options for switching outputs see ["Advanced settings for the outputs"](#), page 134.

8.4.4 Hole detection/hole size

A switching output switches when an object with a hole of a particular size is present in the detection area.

A corresponding setting is configured which requires a certain number of beams or a certain number of **consecutive** beams to be made.

The number of beams is configured in the settings.

The measuring function can be used for **hole detection**, e.g., in a metal sheet, by configuring a number of made beams ≥ 1

- ▶ Select one of the following settings for the hole detection and enter the number of n beams:

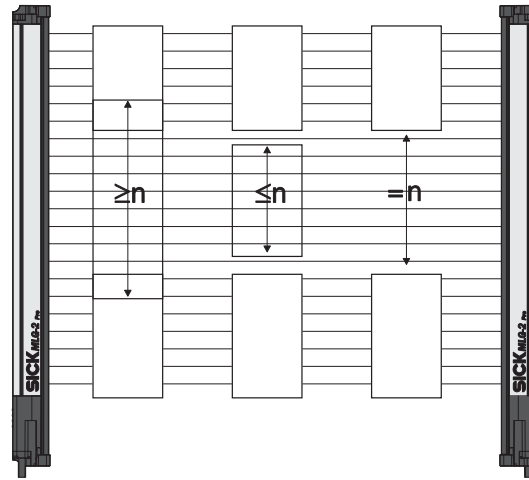

Figure 103: Hole detection/hole size

- **$\geq n$ hole is larger than or equal to n beams:**
The output becomes active when the configured number of beams or more are made.
- **$\leq n$ hole is smaller than or equal to n beams:**
The output becomes active when the configured number of beams or fewer are made.
- **$= n$ hole is equal to n beams:**
The output becomes active if the exact number of configured beams are made.

The hole size that has been set is shown in the **Simulation** area. It can be changed using the mouse.

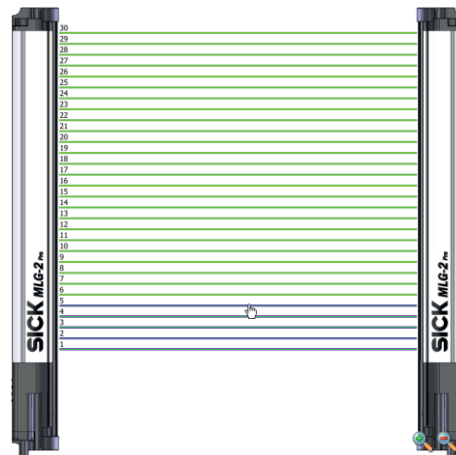

Figure 104: Setting the hole size with the mouse

Only take into account consecutive beams:

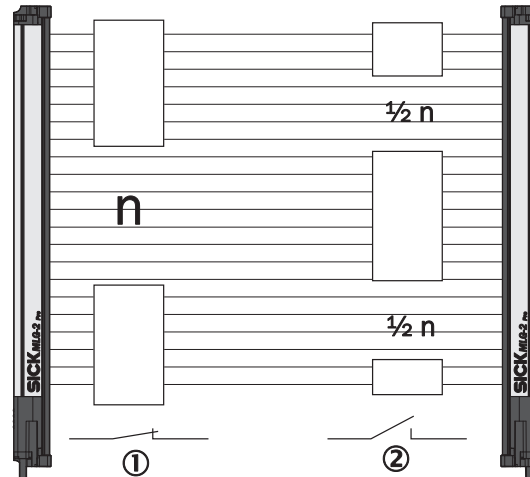

Figure 105: Detection of consecutive beams

- ① Criterion met
- ② Criterion not met

The output becomes active when the beams are made through a single hole. If this option is not activated, the number of made beams can also be made up of several gaps.

Output settings

General options for switching outputs see "Advanced settings for the outputs", page 134.

8.4.5 Outside/inside dimension

A switching output switches when an object with a particular outside or inside dimension is detected.



NOTE

If there are several objects in the detection area, the largest object determines the measured value.

The following settings are possible for measuring the outside or inside dimension:

- Configure whether you want to measure the **outside dimension** or **inside dimension**.

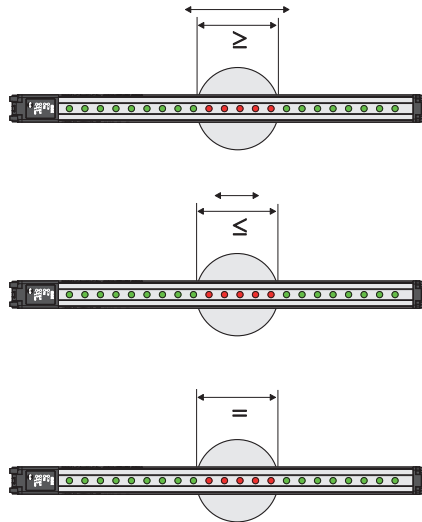

Figure 106: Measurement of the outside dimension

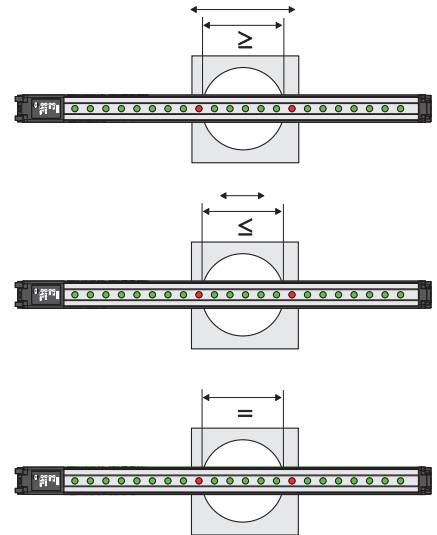

Figure 107: Measurement of the inside dimension

- ▶ Select one of the following settings:
 - **≥ Object diameter is greater than or equal to n beams:**
The output becomes active if the configured number of beams or more were blocked/made.
 - **≤ Object diameter is less than or equal to n beams:**
The output becomes active if the configured number of beams or less were blocked/made.
 - **= Object dimension is equal to n beams:**
The output becomes active if precisely the configured number of beams was blocked/made.

A particular number of beams is configured for the outside or inside dimension in the settings. The object size is shown in the **Simulation** area and can be changed here using the mouse.

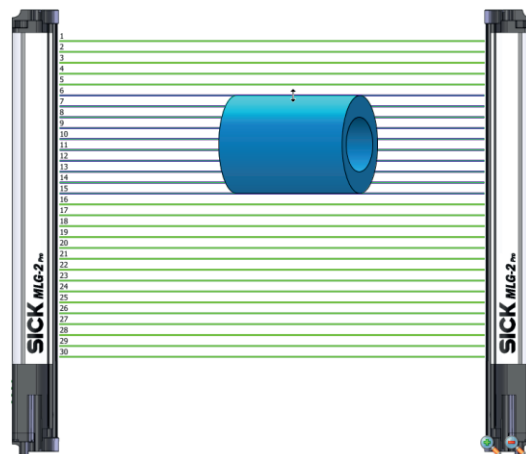

Figure 108: Setting the outside dimension with the mouse

Output settings

General options for switching outputs see "[Advanced settings for the outputs](#)", page 134.

8.4.6 Classification of an object position

A switching output switches when the center of an object is located exactly on the beam configured as the position.



NOTE

If there are several objects in the detection area, the central beam of the largest object determines the object position.

A particular beam is configured for the classification of the object position in the settings.

► Select one of the following settings:

- The object center is greater than or equal to the position of beam number n.

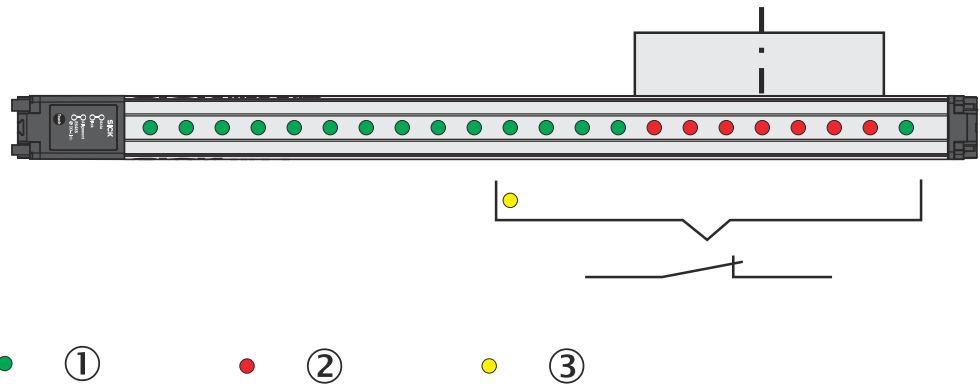

Figure 109: Classification of the object position – object center is greater than or equal to n beam

- ① Made beam
- ② Blocked beam
- ③ Configured beam

- The object center is less than or equal to the position of beam number n.

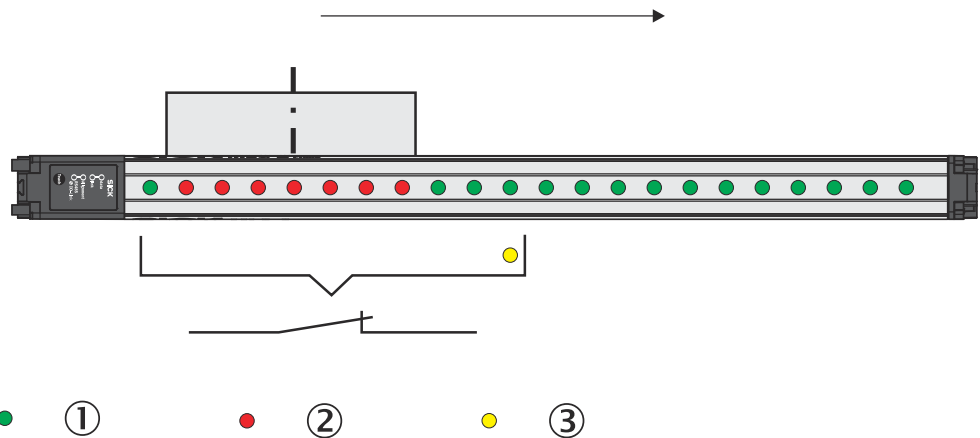

Figure 110: Classification of the object position – object center is smaller than or equal to n beam

- ① Made beam
- ② Blocked beam
- ③ Configured beam

- The object center is equal to the position of beam number n.

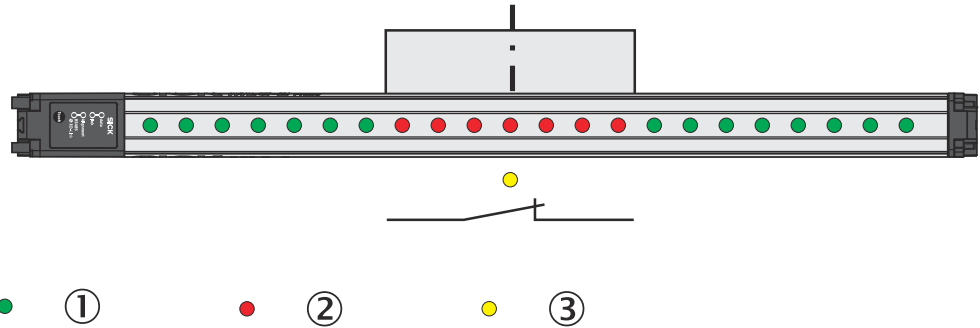

Figure 111: Classification of the object position – object center is equal to n beam

- ① Made beam
- ② Blocked beam
- ③ Configured beam

General options for switching outputs see ["Advanced settings for the outputs", page 134.](#)

The object position that has been set is shown in the **Simulation** area. It can be changed using the mouse.

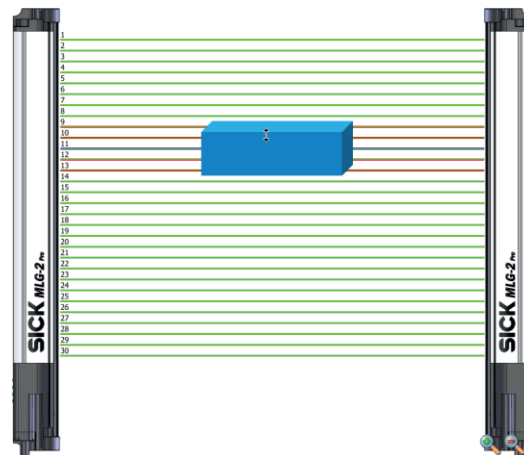

Figure 112: Setting the object position with the mouse

Zone selection

For additional information, see ["Zone measuring" function, page 135 .](#)

8.4.7 Classification of a hole position

A switching output switches when the center of a hole is located on the beam configured as the hole position.



NOTE

If there are several holes in the detection area, the central beam of the largest hole determines the hole position.

A particular beam is configured for the classification of a hole position in the settings.

- ▶ In addition, select one of the following settings:
 - **The hole center is greater than or equal to the position of beam number n .**
The number of the beam located in the center of the hole is greater than or equal to the number of the configured beam.

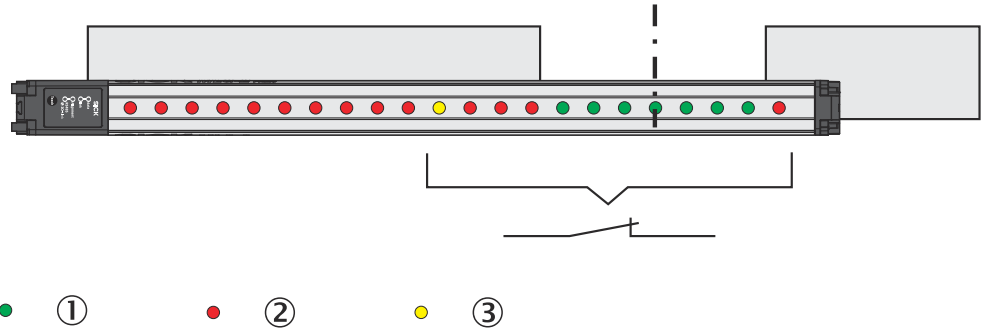

Figure 113: Classification of the hole position – larger than or equal to hole center

- ① Made beam
- ② Blocked beam
- ③ Configured beam

- **The hole center is smaller than or equal to the position of beam number n.**
The number of the beam located in the center of the hole is smaller than or equal to the number of the configured beam.

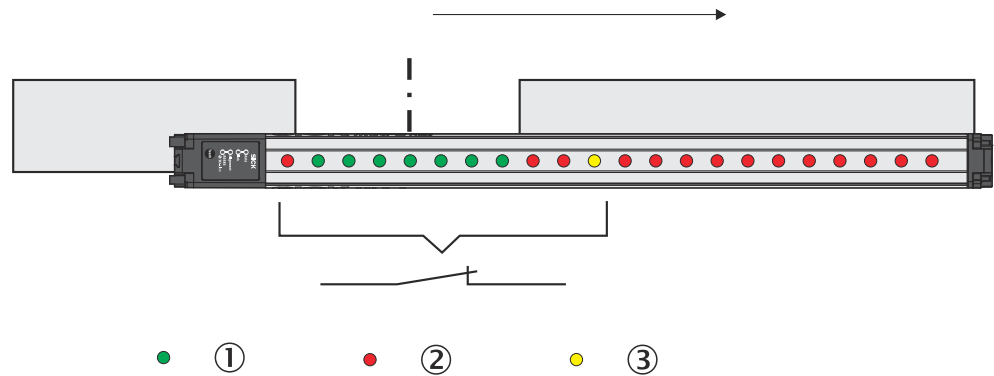

Figure 114: Classification of the hole position – smaller than or equal to hole center

- ① Made beam
- ② Blocked beam
- ③ Configured beam

- **The hole center is equal to the position of beam number n.**
The center of the hole is located exactly at the configured beam.

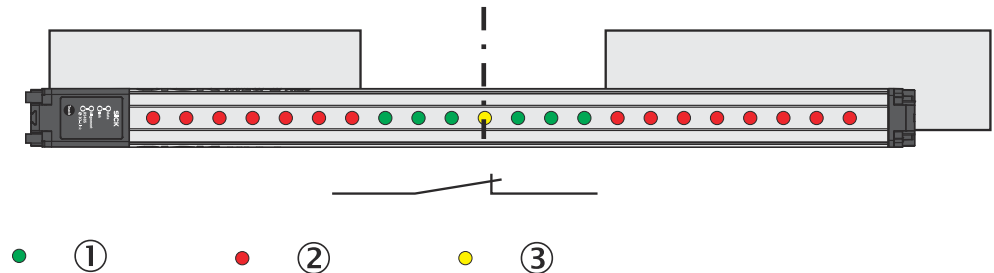

Figure 115: Classification of the hole position – equal to hole center

- ① Made beam
- ② Blocked beam
- ③ Configured beam

The hole position that has been set is shown in the **Simulation** area. It can be changed using the mouse.

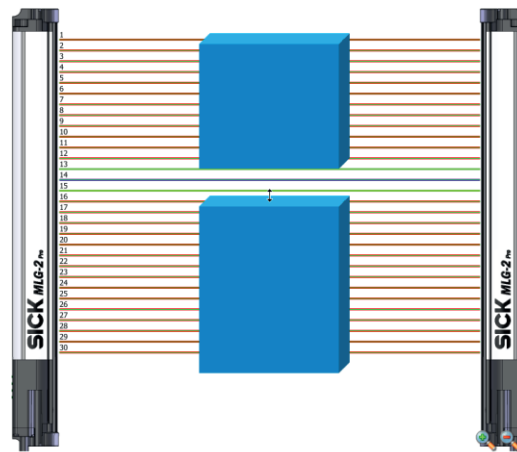

Figure 116: Setting the hole position with the mouse

Output settings

General options for switching outputs see ["Advanced settings for the outputs"](#), page 134.

8.4.8 Diagnostics

As well as measuring functions, diagnostic functions can also be assigned to the outputs. Depending on the configuration, the output will respond when certain faults occur or when the teach-in quality or process quality fall below a configured percentage.

Diagnostic settings

- **Activate Qn in the event of the following error messages:**
 - **Contamination**
The output is activated when a contamination warning occurs.
 - **Electrical short-circuit**
The output is activated when a short-circuit occurs in the wiring.
 - **Teach-in error**
The output is activated when an error occurs during the teach-in process.
 - **Hardware error**
The output is activated when an error occurs with the hardware. Possible cause: LED defective, receiver element defective, etc.
 - **Synchronization error**
Output is activated when there is an error in the connection to the server.
- **Activate Qn if the teach-in quality is under ... %**
The output is activated when the teach-in quality falls below a certain percentage (see ["Teach-in"](#), page 17).
You can define the percentage in increments of 1%.
- **Activate Qn if the process quality is under ... %**
The output is activated when the process quality falls below a certain percentage (see ["Teach-in"](#), page 17).
You can define the percentage in increments of 1%.

Output settings

General options for switching outputs see ["Advanced settings for the outputs"](#), page 134.

8.4.9 Advanced settings for the outputs

For switching outputs, you can select the option **Invert output**.

At the EXPERT user level, you can also enter a **minimum pulse width** for the output signal in ms.

Very fast or small objects trigger a short output signal. Under some circumstances, these may not be detected by slow controls. Via the minimum pulse width, you can set a pulse width that your control will detect.

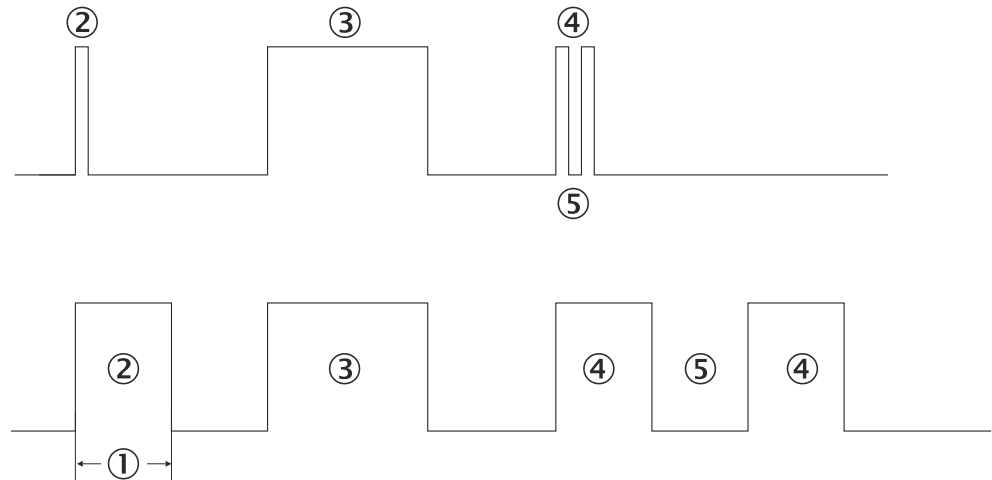

Figure 117: Examples of the effect of a configured minimum pulse width

- ① Minimum pulse width
- ② A pulse that is too short is extended.
- ③ A long output pulse remains unchanged.
- ④ Two short output pulses are extended.
- ⑤ The break also corresponds to the minimum pulse width (1).

Activating the output (only at the EXPERT user level)

At the EXPERT user level, you can also configure a setting so that an output only changes its status when a particular input is activated. This method can be used to switch the measuring function on or off.

- ▶ Click **Advanced...**
- ▶ Activate the option **Use input to activate or deactivate output**.
- ▶ Select which input is to be used.
- ▶ You should also configure whether the input is to be **high active** or **low active**.



NOTE

This function is only available if the inputs have not been configured for other functions (see "System settings for the EXPERT user level", page 118).

8.5 Zones

8.5.1 "Zone measuring" function

Prerequisites

- "Expert" user level

Description of operation

The beams of the MLG-2 can be divided into four zones. Each zone can be assigned one beam function or application. Zones and beam functions are assigned using the outputs. The functions NBB Zone n, LBB Zone n, FBB Zone n, CBB Zone n and NCBB Zone n are available for each zone (n = 1, 2, 3 or 4).

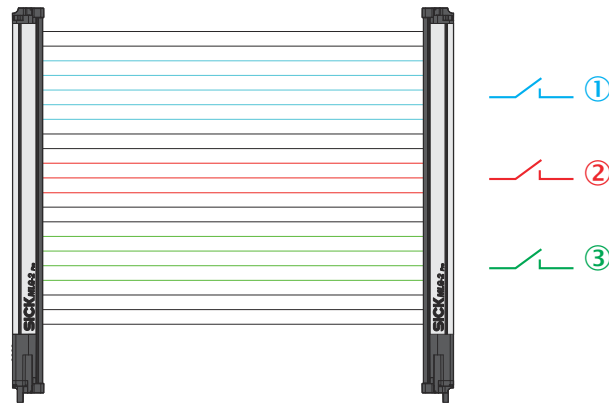

Figure 118: Measuring within zones

- ① e.g. Zone 1 (NBB Zone 1, LBB Zone 1, FBB Zone 1, CBB Zone 1 or NCBB Zone 1)
- ② e.g. Zone 2 (NBB Zone 2, LBB Zone 2, FBB Zone 2, CBB Zone 2 or NCBB Zone 2)
- ③ e.g. Zone 3 (NBB Zone 3, LBB Zone 3, FBB Zone 3, CBB Zone 3 or NCBB Zone 3)

Configuring the “Zone measuring” function using SOPAS ET

Example: You would like to assign Zone 1 and the application “Object detection/Object width (NBB/NCBB)” to digital output 1.

First, configure one or more zones. Next, assign an application and a zone to the desired output. You can configure the zones either in the beam window or via the **Zones** expandable menu.

Configuring zones in the beam window

- ▶ Click the **Zones** expandable menu.
- ▶ In the middle section of SOPAS ET (beam window), mark the beams that you would like to combine into a zone.
- ▶ Using **Combine to a zone** from the context menu, select the zone that the beams will be assigned to – in this case **Zone 1**.

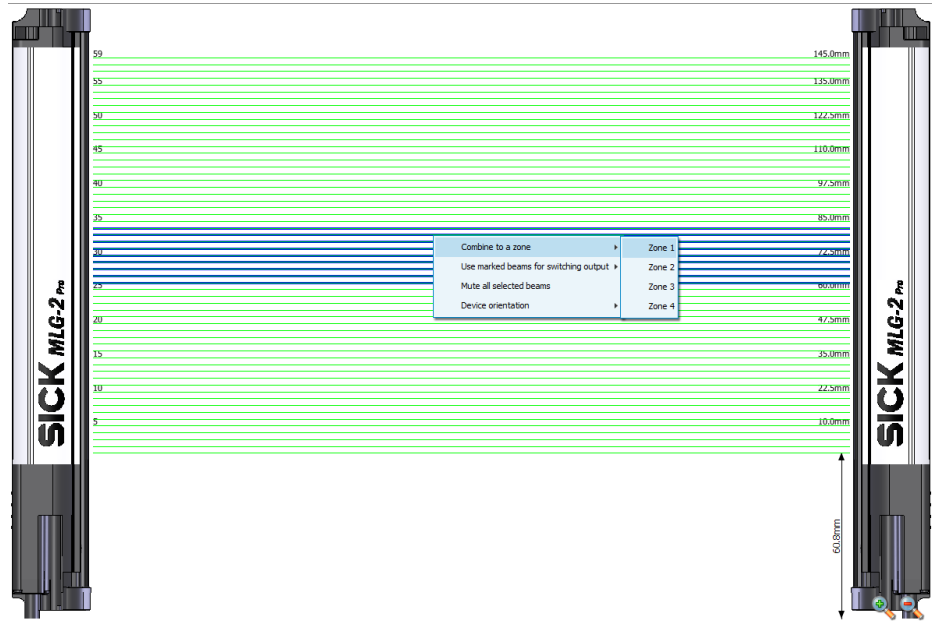

Figure 119: SOPAS ET beam window – Combining beams into zones

- ✓ The configured zones are indicated in the **Zones** expandable menu.

Configuring **Zones** in the expandable menu

- ▶ Click the **Zones** expandable menu.
- ▶ In the **Zone selection** area, define the “Zone no.”, “First beam” and “Last beam” for the zone.

Zone Nr.	First b...	Last be...
1	14	21
2	4	11
3	1	1
4	1	1

- ▶ Activate the zone you wish to assign to an output.

Configuring an output

- ▶ Click the **Digital output 1** expandable menu, for example.

Digital output 1

Applications

- Height classification (LBB/FBB)
- Height measurement of free space (LBM/FBM)
- Object recognition (RLC)
- Presence detection of objects (NBB/NCBB)**
- Presence detection of holes (NBM/NCBM)
- Outer dimension/Inner dimension (ODI/IDI)
- Position classification of object (CBB/BNB)
- Position classification of hole (CBM/BNM)

Zone Selection

- Zone 1 ▼
- All Rays
- Zone 1**
- Zone 2
- Zone 3
- Zone 4

Ma... larger or equal than ▼ 1 beams

Figure 120: SOPAS ET – Assigning an application and zone to an output

- ▶ In the **Applications** area, select an application such as **Object detection/Object width (NBB/NCBB)**.
- ▶ Using the drop-down list from the **Zone selection** area, select the zone that the application will apply to – in this case **Zone 1**.
- ✓ The configured basic function (beam function) and the related status are displayed in the **Basic functions** area of the **I/O** tab in the left-hand window, e.g., **NBB Zone 1 = 0** (number of blocked beams in Zone 1).

8.6 Teach-in

During the teach-in process, the switching thresholds for all beams are individually adjusted for the sensing range and the ambient conditions.

A teach-in process must be carried out when commissioning, when changing operating mode or performance options, and at regular intervals in general.

- ▶ Click **Teach-in**.
- ✓ The teach-in process starts. If the teach-in process is successful, a corresponding message is displayed.

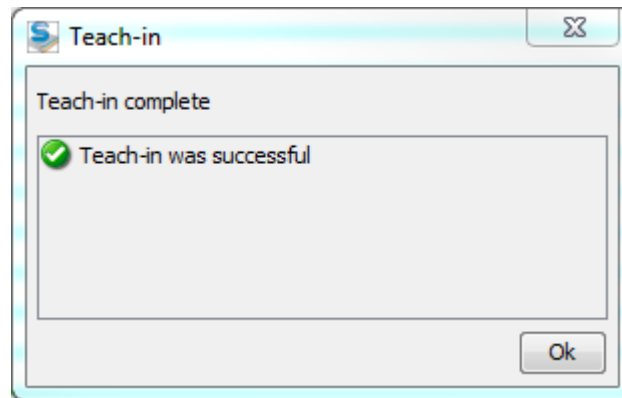

Figure 121: Teach-in successful

Similarly, if any errors occur, a corresponding message is displayed.

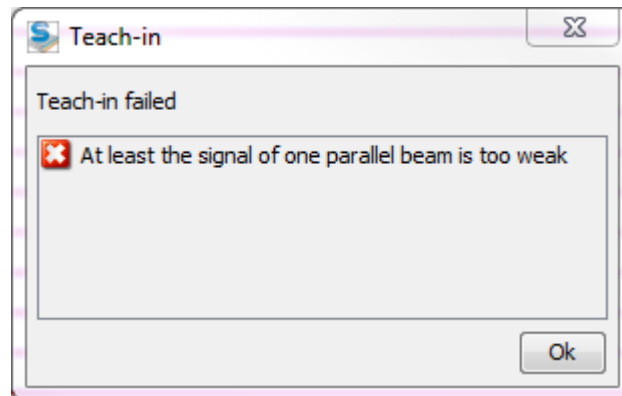

Figure 122: Teach-in failed

- ▶ Then check that the MLG-2 is correctly aligned, that the front screens are clean, and that there are no objects located in the light path.
- ▶ Then carry out the teach-in process again.

Teach-in when switching on

If you activate the **Automatic teach-in when switching on device** option, the teach-in process will be performed every time you switch on the device.

Teach-in quality

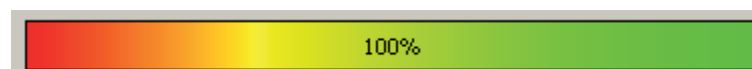

Figure 123: Teach-in quality

The teach-in quality indicates how successful the teach-in process has been. The MLG-2 calculates this value based on the quality of the light level received.

The value remains constant until another teach-in process is carried out.

Beam blanking (only at the EXPERT user level)

If you do not want to evaluate certain beams for your application, you can exclude them from the teach-in process.

Blank blocked beams as follows:

The beams from the MLG-2 that are **not** to be accounted for in the measurement must be blocked.

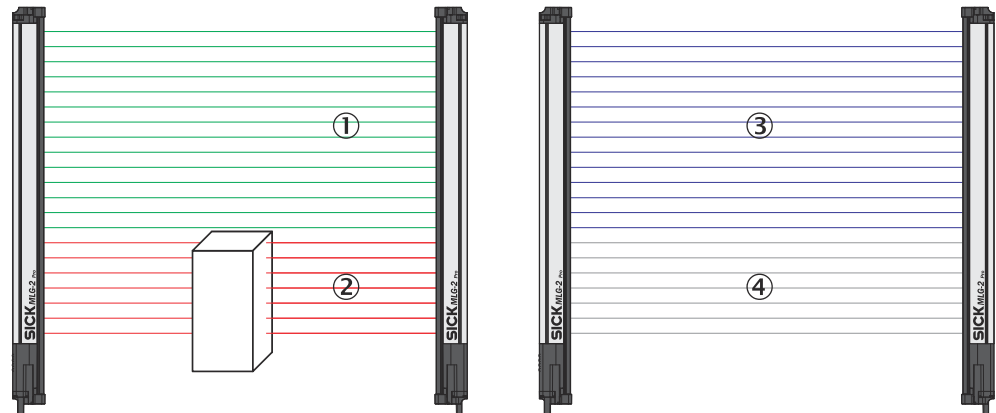

Figure 124: Example of the blanking of blocked beams

- ① Made beams
- ② Blocked beams
- ③ Beams included in the measurement
- ④ Excluded beams

- ▶ Click **Blank all blocked beams**.
- ✓ The blocked beams will not be taken into account in the measurement.
- ▶ Activate the **Activate beam blanking for every teach-in** option too.
- ✓ The blocked beams will be excluded from every teach-in process in the future.



NOTE

You will never be notified that beams are blocked during the teach-in process.

Blank made beams as follows:

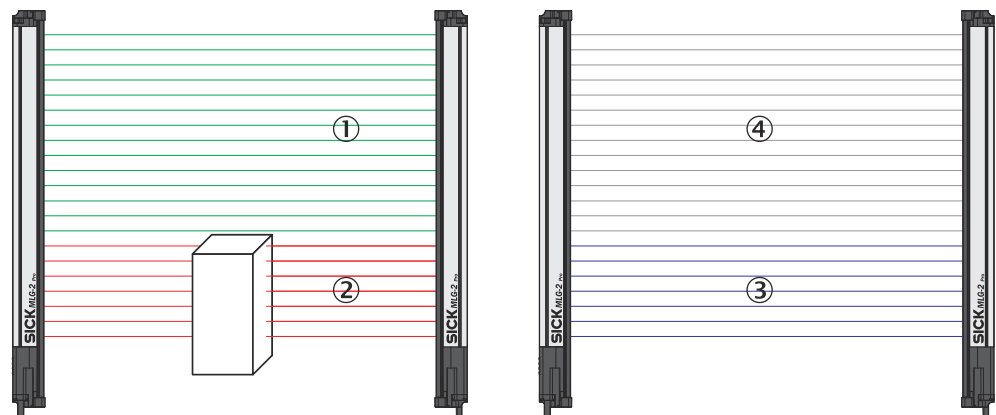

Figure 125: Example of blanking made beams

- ① Made beams
- ② Blocked beams

- ③ Beams included in the measurement
- ④ Excluded beams
- ▶ Click **Blank all made beams**.
- ✓ The made beams will not be taken into account in the measurement.
- ▶ Activate the **Activate beam blanking for every teach-in** option too.
- ✓ The made beams will be excluded from every teach-in process in the future.

8.7 Performance options

The performance options can be used to modify the response time, operating reserve, detection type, and (in Transparent operating mode), minimum detectable absorption of an object.

Responsetime

fast
—
—
—
low

High speed
High speed scan active
Cross beam inactive
Recommended for high speed processes

Function Reserve

— high
—
—
— low

Standard
Best compromise
Recommended for indoor applications

Detection type
Adjust object size to smallest object which needs to be detected in the application.

Object Speed
Height
Length

50mm
50mm

Figure 126: Performance options for Standard operating mode and Dust- and sunlight-resistant operating mode

Responsetime

– fast
– slow

Standard
High speed scan inactive
Parallel beam scan
i Suitable for most processes

Minimum Detectable Absorption

– 30%
– 10%

Approx. 15% signal attenuation
AutoAdapt active
i Regular Teach-in recommended

Detection type
Adjust object size to smallest object which needs to be detected in the application.

Object Speed
Height
Length

Figure 127: Performance options for Transparent operating mode

You can change the response time, operating reserve, or minimum detectable absorption by moving the slider up or down.



NOTE

- The configurable performance options depend on the operating mode selected.
- The performance options are dependent on each other.
- A teach-in process must be performed after most changes. A button is provided in the performance options for this purpose.
- ▶ Click the button to perform the teach-in process and to apply the modified performance options.
- ✓ The system boundaries resulting from the performance options are displayed on the left in SOPAS ET (see "System boundaries and status", page 110).

Response time

The response time depends on the scan method and the beam function. A short response time requires a **high-speed scan** and the **parallel-beam function**.

- ▶ Select one of the following options:
 - **Fast** – High-speed scan and parallel-beam function are active
 - **Medium** – High-speed scan not active and parallel-beam function active

**NOTE**

- If **High-speed scan** is deactivated in the energy options, you cannot switch to **Fast**.
- Only **Medium** can be set in Transparent operating mode.
- If the cross beam function is activated via **Detection type**, the system switches to **Slow**.
- For MLG-2 with a 2 m sensing range, the high measurement accuracy function must be used for **High-speed scan**.

Operating reserve

The operating reserve affects how long the measurement can be performed correctly in the event of adverse ambient conditions or contamination.

- **High** – Highly resistant to contamination, risk of reflection with shiny objects
- **Medium** – Best compromise between reflection resistance and operating reserve
- **Low** – High measurement accuracy

**NOTE**

It is not possible to set an operating reserve in **Transparent** operating mode.

Minimum detectable absorption of an object (only in Transparent operating mode)

The minimum detectable absorption (MDA) of an object must be configured in **Transparent** operating mode. In order to detect a transparent object, it must absorb a certain percentage of the energy from the light beam.

The following options are available for configuring the minimum detectable absorption⁷⁾:

- Approx. 10% signal attenuation:
clean PET bottles, clear glass, thin and clear films (e.g., cellophane), household plastic film, plastic wrapping
- Approx. 15% signal attenuation:
clean clear glass bottles, thick films, film and wrapping folded multiple times
- Approx. 30% signal attenuation:
green and brown glass, colored glass bottles

**NOTE**

The minimum detectable absorption that an object needs in order to be detected increases with the sensing range (see "[Minimum detectable absorption](#)", page 165).

Detection type

With the help of the mapped object, you can set the minimum detectable object size and minimum detectable object length, and enter the speed of the object through the detection area.

The object speed and size determine which scanning procedure is to be used.

- ▶ Enter the speed at which the object being detected will move through the detection area in the **Object speed** field.
- ▶ Enter the height of the smallest object to be detected in the **Height** field.
- ▶ Enter the length of the smallest object to be detected in the **Length** field.

The figure to the right of the fields shows the entered values in proportion.

⁷⁾ Examples are for illustrative purposes only. The signal attenuation and the minimum detectable absorption to be configured must be determined for each individual application.



Figure 128: Illustration of the measuring object

8.7.1 “Cross beam” function

Prerequisites

- “Expert” user level
- Reasonable beam separation: ≥ 10 mm
- Possible operating modes: standard or dust- and sunlight-resistant
- High-speed scan is deactivated.
- The object being detected is located in the center section of the detection area.
- Only for “Cross beam measuring”: ≤ 255 beams

Notes

- [see "Minimum detectable object with cross-beam function ", page 23](#)

Description of operation

The MLG-2 offers the following beam functions: “Parallel beam”, “Cross beam switching” and “Cross beam measuring.” The system automatically selects the “Parallel beam” or “Cross beam switching” function depending on the specific object size that is to be detected. As an alternative, the user also has the option of manually activating the “Cross beam switching” or “Cross beam measuring” function.

In the “Cross beam switching” option, the crossed beams are also used for object detection. The crossed beams do not affect the beam status, beam functions or blanked beams.

In the “Cross beam measuring” function, a group of crossed beams is combined into a single virtual beam. Virtual beams are treated as additional real beams and do not have any affect on the beam status, beam functions or blanked beams. If the “Cross beam measuring” function is activated, the real and virtual beams are renumbered, which means that the number of beams is nearly doubled.

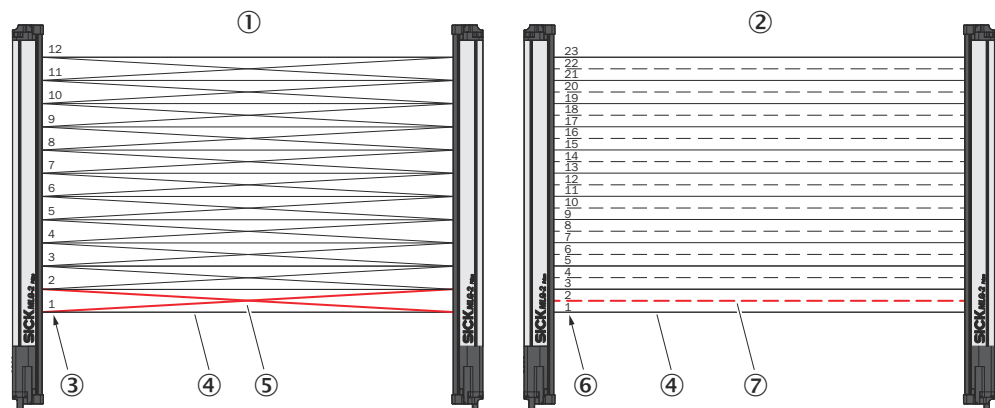

Figure 129: Left: “Cross beam switching”, right: “Cross beam measuring”

- ① Cross beam switching
- ② Cross beam measuring
- ③ Beam numbering for “Cross beam switching”
- ④ Parallel beam
- ⑤ Crossing beams

- ⑥ Beam numbering for “Cross beam measuring”
- ⑦ Crossing beams, displayed as a virtual beam

Example with “Cross beam measuring”

When the “Cross beam switching” function is used, a light grid with a beam separation of 20 mm can detect a wide object with a thickness of 1 mm, but cannot output a measured value for the height, for example. With the “Cross beam measuring” function, it is also possible to output a measured value for the height.

Configuring the “Cross beam switching” function using SOPAS ET

- ▶ In SOPAS ET, click on the **Performance options** expandable menu in the right-hand window.
- ▶ In the **Operating reserve** area, enable the **Activate cross beam mode** function.

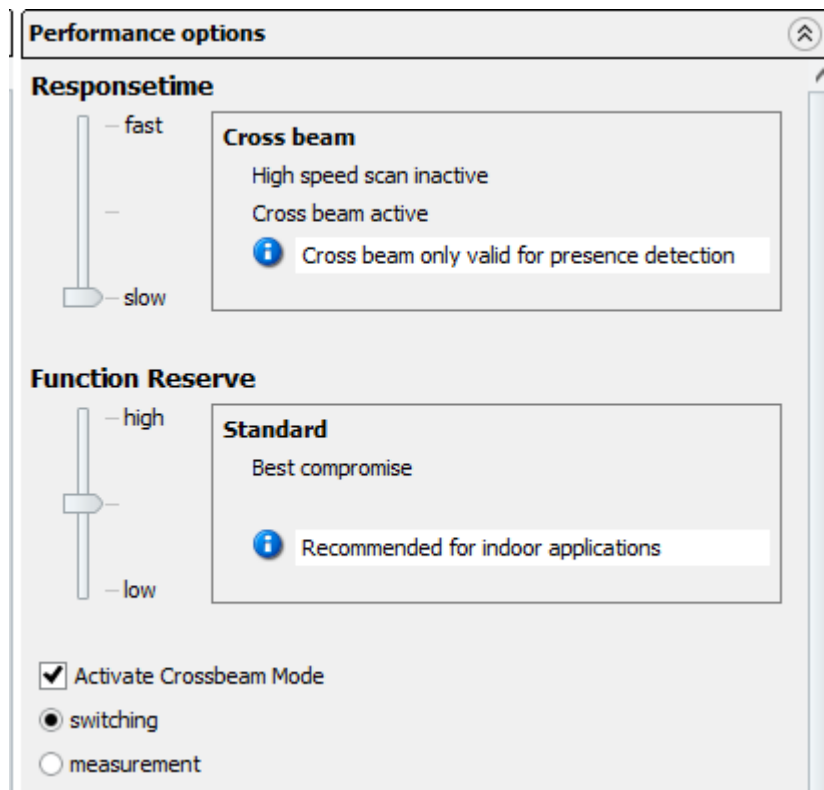

Figure 130: SOPAS ET – Activating cross beam switching mode

- ▶ Select the **switching** function.
- ✓ The “Cross beam switching” function is now activated.

Configuring the “Cross beam measuring” function using SOPAS ET



NOTICE

If the “Cross beam measuring” function is activated, the real and virtual beams are renumbered. Existing configurations are not converted. Check the existing configuration for the “Cross beam measuring” function. Adjust the configuration accordingly.

- ▶ In SOPAS ET, click on the **Performance options** expandable menu in the right-hand window.
- ▶ In the **Operating reserve** area, enable the **Activate cross beam mode** function.

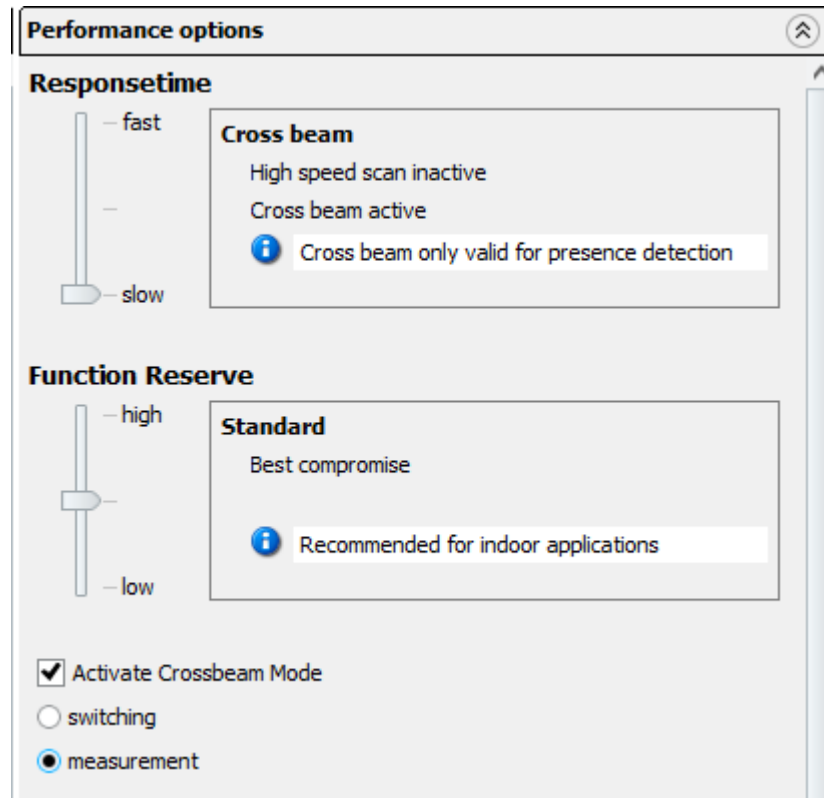

Figure 131: SOAPS ET – Activating cross beam measuring mode

- ▶ Select the **measuring** function.
- ✓ The following dialog box will open: **Warning. Activating this function will increase the number of beams. All beam-dependent settings must be adjusted accordingly.**

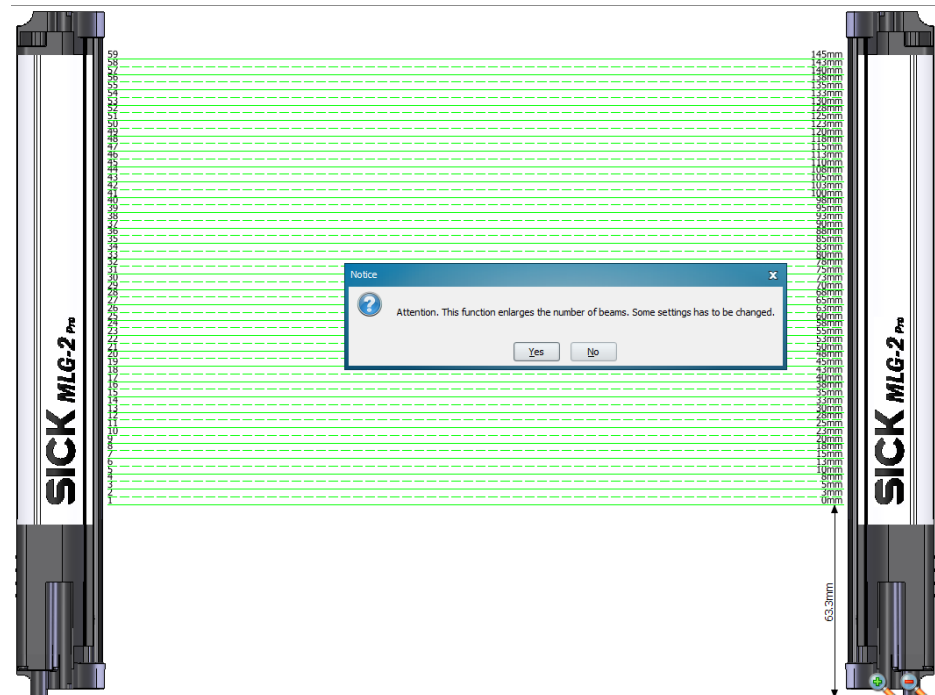

Figure 132: SOAPS ET, beam window – “Cross beam measuring” display

- ▶ Click **Yes** to activate the **Cross beam measuring mode**. Click **No** to cancel.
- ✓ The light grid display is adjusted in the middle section (beam window). The real

and virtual beams are renumbered and, as a result, the number of beams is nearly doubled. The virtual beams are displayed as dashed lines.

- ▶ Check the existing configuration for the “Cross beam measuring” function.
- ▶ Adjust the configuration for the “Cross beam measuring” function accordingly.

8.7.2 Energy option (only at the EXPERT user level)

Deactivating the high-speed scan function

Since the high-speed scan function results in a higher current consumption, it can be deactivated. In this case, the function cannot be activated again via the response time slider.

8.8 Beam evaluation

8.8.1 “Blocked Beams Hold (BBH)” evaluation mode

Prerequisites

- “Expert” user level

Notes

- You can choose one of the following evaluation modes: Standard, Blocked Beams Hold (BBH) or Lost Beams Hold (LBH).
- You can select the “Blocked Beams Hold (BBH)” evaluation mode for one beam function or for multiple beam functions simultaneously.

Description of operation

The “Blocked Beams Hold (BBH)” evaluation mode is activated by a trigger signal on the hardware input or via a trigger command from the fieldbus. If this evaluation mode has been activated, any beams that have been blocked are saved and displayed as blocked beams. Once the evaluation mode is deactivated by a withdrawal of the trigger signal, the blocked beams are reset to made beams.

You can select the “Blocked Beams Hold (BBH)” evaluation mode for each individual beam function or for multiple beam functions simultaneously. As a result, beam functions for which the “Blocked Beams Hold (BBH)” evaluation mode was configured are calculated based on this evaluation mode.

Configuring the “Blocked Beams Hold (BBH)” function using SOPAS ET

Figure 133: SOPAS ET – “Blocked Beams Hold (BBH)” function

- ▶ In SOPAS ET, click on the **Beam evaluation** expandable menu in the right-hand window.
- ▶ In the **Evaluation mode** area, select the **Blocked Beams Hold (BBH)** evaluation mode.
- ✓ The message **Blocked Beams Hold selected. This function only affects the selected basic functions.**
- ▶ In the **BBH beam function** area, activate the beam functions for which the Blocked Beams Hold evaluation mode will be used.
- ▶ If the evaluation mode is to be activated and deactivated using a hardware input, check the **Use digital input to activate BlockedBeamsHold** box.
- ▶ Select the desired digital input from the drop-down list.
Please note that you can only assign one function to an input. If necessary, you must deactivate the **Use digital input to start teach process** option in the **Teach-in** expandable menu.
- ✓ In the **I/O** tab in the left-hand window, the beam functions for which the output mode was selected are marked by **(BBH)**. The message **TRIGGER_BBH_MODE** is displayed in the **Input/Output status** area if the “BBH” evaluation mode was activated by an input.

8.8.2 “Lost Beams Hold (LBH)” evaluation mode

Prerequisites

- “Expert” user level

Notes

- You can choose one of the following evaluation modes: Standard, Blocked Beams Hold (BBH) or Lost Beams Hold (LBH).
- The “Lost Beams Hold (LBH)” evaluation mode affects all beam functions.

Description of operation

In the “Lost Beams Hold (LBH)” evaluation mode, a blocked beam is displayed as a blocked beam until a new beam is blocked. This allows the position to be determined for objects that are smaller than the minimum detectable object.

This evaluation mode assumes that the object being detected is always positioned within the detection area. This means that the object must be located either above or below the last beam blocked when a previously blocked beam is no longer blocked and a different beam is not yet blocked. Once the object blocks a different beam, this new position is detected and the saved last beam blocked is deleted. If the object moves outside the detection area, the last beam blocked remains blocked.

Example

The “Lost Beams Hold (LBH)” output mode is used to detect the position of thin objects that are no longer detected by a parallel beam.

Configuring the “Lost Beams Hold (LBH)” function using SOPAS ET

Figure 134: SOPAS ET – “Lost Beams Hold (LBH)” function

- ▶ In SOPAS ET, click on the **Beam evaluation** expandable menu in the right-hand window.
- ▶ In the **Evaluation mode** area, select the **Lost Beams Hold (LBH)** evaluation mode.
- ✓ The message **Lost Beams Hold selected.** is displayed in the **Configuration** area. **This function affects all process data.**
- ✓ At the bottom of the **I/O** tab in the left-hand window, the beam evaluation mode **OFF**, **Blocked Beams Hold** or **Lost Beams Hold** is displayed.

8.9 Simulation

If you configure an MLG-2 offline – i.e., without a connection to the device – you can simulate the operation of the MLG-2 using simulation objects. The objects required for the simulation can be set via the expandable **Simulation** menu. This includes the number of objects, their shape, size, and speed.

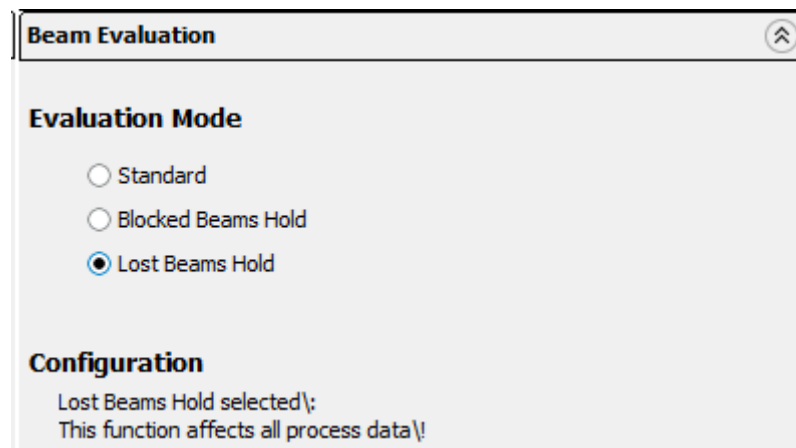
- ▶ Click on the plus sign to add a simulation object.

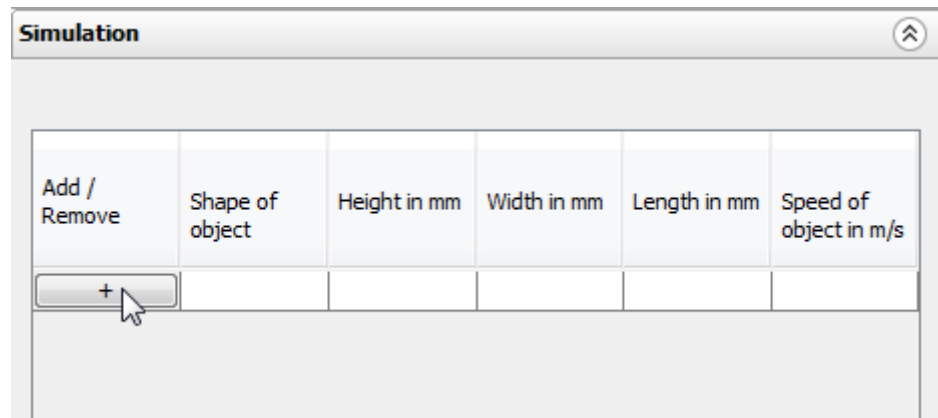

Figure 135: Add simulation object

- ▶ Select the object shape.

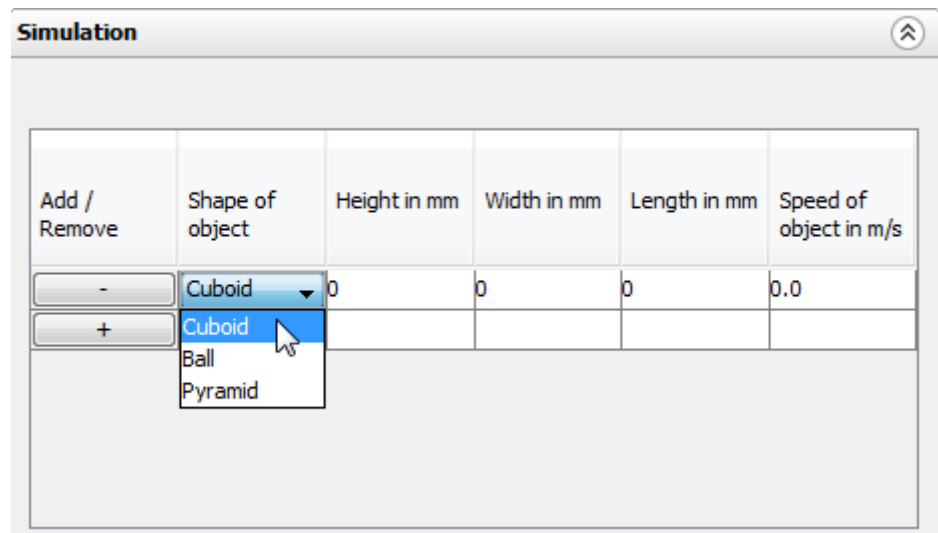

Figure 136: Determine the shape of the simulation object

- ▶ Enter the height, width, and length in mm. Enter the object speed in m/s.

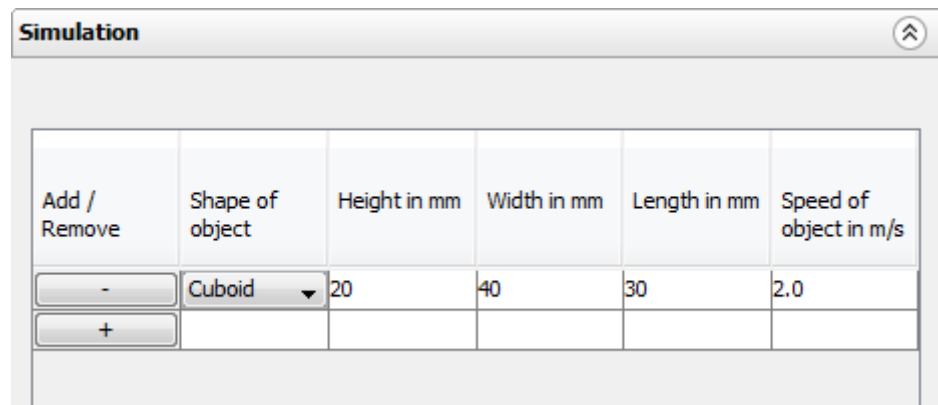

Figure 137: Determine the size of the simulation object

- ▶ Click **Start simulation**.

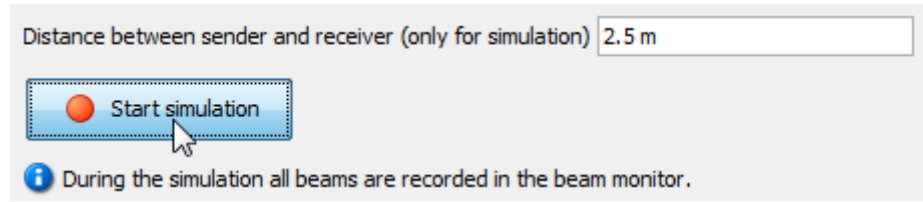

Figure 138: Start simulation

- ✓ The configured simulation object is moved through the MLG-2 in the **Simulation** area.

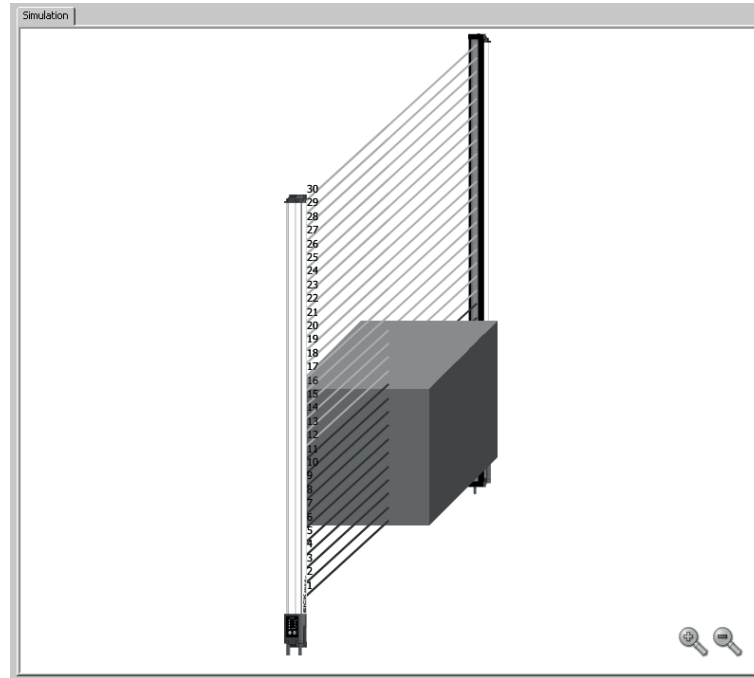

Figure 139: Simulation object in Simulation area

8.10 Beam monitor (only in the EXPERT user level)

If SOPAS ET is connected to an MLG-2, the **Beam monitor** tab shows the current beam status as a function of time as well as the status of the configured outputs.

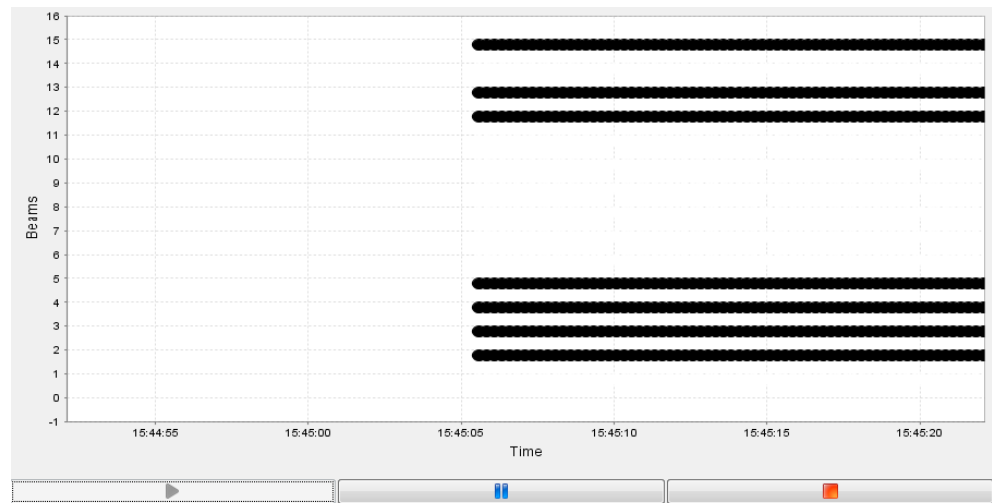

Figure 140: Beam status

This not only shows whether the beam is blocked or made, but also indicates partial coverage of the beam using grayscale, i.e., a half-blocked beam is shown in 50% gray.

If an object is moved through the detection area within the simulation while offline, the made and blocked beams are recorded just as in online operation. If the object is moved using the mouse, only the static beam status is displayed.

8.11 Function programming (in the EXPERT user level)

Function programming can be used to carry out complex applications with variables, operands, and functions in the **EXPERT** user level.

1st option:

“Beam function variables” can be defined in the **Beam function variables** area using the beam functions (see ["Beam functions"](#), page 153).

Example:

BFVar 1: Total number of beams made (NBM) \geq 30

These variables can be linked directly to the outputs in the **Switching outputs** area.

Example:

Q1 = BFVar 1 = true

Output Q1 switches when the total number of beams made is greater than or equal to 30.

2nd option:

Multiple beam function variables can be defined in the **Beam function variables** area using the beam functions (see ["Beam functions"](#), page 153).

Example:

BFVar 1: Number of beams made (NBM) \geq 30

BFVar 2: Number of consecutive beams blocked (NCBB) = 5

These can be linked to logical variables in the **Logical variables** area.

Example:

LogVar1 = BFVar 1 OR BFVar 2

The logical variables can be linked in turn to the outputs (Q) in the **Switching outputs** area.

Example:

Q1 = LogVar1

The output Q1 switches when the total number of beams made is greater than or equal to 30 or when the number of consecutive beams blocked equals 5.



NOTE

If outputs have already been configured using the operating elements available in the **Easy** user level, these settings will be automatically transferred to the **Function programming** view.

Beam function variables				
Name	Beam Function	Operation	Value	Result
BFVar1	ODI	≤	10	
BFVar2	LBB	=	15	
BFVar3	NBB	=	0	
BFVar4	NBB	=	0	
BFVar5	NBB	=	0	
BFVar6	NBB	=	0	
BFVar7	NBB	=	0	
BFVar8	NBB	=	0	
BFVar9	NBB	=	0	
BFVar10	NBB	=	0	

Combination of logical variables				
Name	BFVar/Input	Operation	BFVar/Input	Result
LogVar1	BFVar1	AND	BFVar1	
LogVar2	BFVar1	AND	BFVar1	
LogVar3	BFVar1	AND	BFVar1	
LogVar4	BFVar1	AND	BFVar1	
LogVar5	BFVar1	AND	BFVar1	
LogVar6	BFVar1	AND	BFVar1	
LogVar7	BFVar1	AND	BFVar1	
LogVar8	BFVar1	AND	BFVar1	
LogVar9	BFVar1	AND	BFVar1	
LogVar10	BFVar1	AND	BFVar1	

Digital outputs/virtual outputs		
Name	Connection	Variable
Q1	=	ZONE1
Q2 (virtual)	=	BFVar2
Q3 (virtual)	=	BFVar3
Q4 (virtual)	=	BFVar4
Q5 (virtual)	=	OT1
Q6 (virtual)	=	OT1
Q7 (virtual)	=	OT1
Q8 (virtual)	=	OT1
Q9 (virtual)	=	OT1
Q10 (virtual)	=	OT1
Q11 (virtual)	=	OT1
Q12 (virtual)	=	OT1
Q13 (virtual)	=	OT1
Q14 (virtual)	=	OT1
Q15 (virtual)	=	OT1
Q16 (virtual)	=	OT1

Figure 141: Function programming

8.11.1 Beam functions

Table 153: Beam functions for preliminary evaluation

Name	Function (English)	Function (German)	Description
NBB	Number of Beams Blocked	Anzahl unterbrochener Strahlen	Total number of beams blocked (e.g., for object detection)
NBM	Number of Beams Made	Anzahl freier Strahlen	Total number of beams made (e.g., for hole detection)
NCBB	Number of Consecutive Beams Blocked	Anzahl zusammenhängender unterbrochener Strahlen	If there are multiple objects in the detection area, the greatest number of consecutive beams blocked is displayed.
NCBM	Number of Consecutive Beams Made	Anzahl zusammenhängender freier Strahlen	If there are multiple gaps in the detection area, the greatest number of consecutive beams made is displayed.
LBB	Last Beam Blocked	Letzter unterbrochener Strahl	Beam number of the last beam blocked (e.g., for object height measurement)
LBM	Last Beam Made	Letzter freier Strahl	Beam number of the last beam made
FBB	First Beam Blocked	Erster unterbrochener Strahl	Beam number of the first beam blocked (e.g., for height classification of a hanging object)
FBM	First Beam Made	Erster freier Strahl	Beam number of the first beam made
ODI	Outside Dimension	Außenmaß	Total number of beams between the first and last beams blocked (e.g., for measuring the outside dimension)
IDI	Inside Dimension	Innenmaß	Total number of beams made between the first and last beams blocked (e.g., for measuring the inside dimension)
CBB	Central Beam Blocked	Zentraler unterbrochener Strahl	Beam number of the central beam blocked (e.g., for measuring an object position)
CBM	Central Beam Made	Zentraler freier Strahl	Beam number of the central beam made (e.g., for measuring a hole position)
BNB	Beam Number Blocked	Strahlnummer x unterbrochen	True when a predefined beam is blocked
BNM	Beam Number Made	Strahlnummer x frei	True when a predefined beam is made
ALARM Q1	-	-	Configuration same as with SOPAS ET
QoR	Quality of Run	Process quality	0 ... 100 percent
QoT	Quality of Teach	Teach-in quality	0 or 100 in percent 0 = teach-in was unsuccessful 100 = teach-in was successful
RLC1 ... 16	Run-length code	-	Outputs the value of the relevant change
NBB Zone X (X = 1, 2, 3 or 4)	Number of Beams Blocked Zone X	Number of Beams Blocked Zone X	Total number of beams blocked (e.g., for object detection) in the indicated zone

Name	Function (English)	Function (German)	Description
NCBB Zone X (X = 1, 2, 3 or 4)	Number of Consecutive Beams Blocked Zone X	Number of Consecutive Beams Blocked Zone X	If there are multiple objects in the detection area, the greatest number of consecutive beams blocked in the indicated zone is displayed.
FBB Zone X (X = 1, 2, 3 or 4)	First Beam Blocked Zone X	First Beam Blocked Zone X	Beam number of the first beam blocked (e.g., for object height measurement) in the indicated zone
LBB Zone X (X = 1, 2, 3 or 4)	Last Beam Blocked Zone X	Last Beam Blocked Zone X	Beam number of the last beam blocked (e.g., for object height measurement) in the indicated zone
CBB Zone X (X = 1, 2, 3 or 4)	Central Beam Blocked Zone X	Central beam blocked in Zone X	Beam number of the central beam blocked (e.g., for measuring an object position) in the indicated zone

9 Configuration of MLG-2 with the internal web server

The MLG-2 has an integrated web server which can be used to configure the MLG-2 even without SOPAS ET. However, not all parameters can be configured, and the web server does not provide the same diagnostics options.



NOTE

The interface is only available in English.

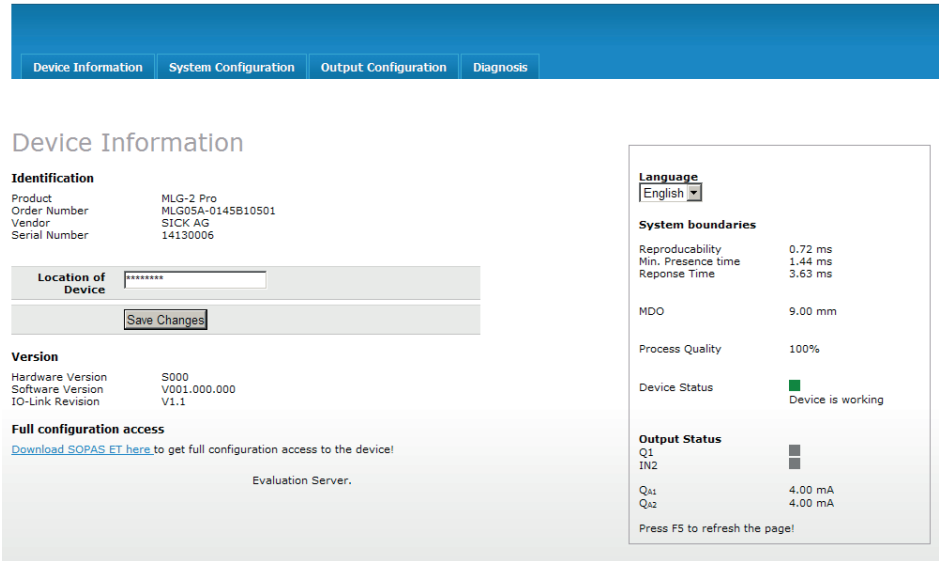

Figure 142: Interface of the integrated web server

Accessing the web server

The MLG-2 web server is accessed via the IP address of the MLG-2.

On delivery, DHCP is deactivated and the static IP address 192.168.200.100 is set.

If DHCP is activated and a DHCP server is on the network, the MLG-2 obtains the IP address from this server. You can look up the IP address there.

The MLG-2 supports universal plug and play. This means that you can also find the IP address in the system settings of your Windows PC/notebook.

Working with the web server

The displayed values are not always updated automatically. The browser page may therefore need to be refreshed (e.g., by pressing F5).

10 Servicing

The MLG-2 measuring automation light grid is maintenance-free. Depending on the ambient conditions, regular cleaning is required.

Depending on the ambient conditions of the MLG-2, the front screens must be cleaned regularly and in the event of contamination. Static charges can cause dust particles to be attracted to the front screen.



NOTE

- ▶ Do not use aggressive cleaning agents.
 - ▶ Do not use abrasive cleaning agents.
 - ▶ Do not use cleaning agents that contain alcohol, e.g., window cleaner.
-

We recommend anti-static cleaning agents.

We recommend the use of anti-static plastic cleaner (SICK part number 5600006) and the SICK lens cloth (SICK part number 4003353).

How to clean the front screen:

- ▶ Use a clean, soft brush to remove dust from the front screen.
- ▶ Then wipe the front screen with a clean, damp cloth.
- ▶ Check the position of the sender and receiver after cleaning.
- ▶ Perform the teach-in process on the MLG-2 again. To do this, press the **Teach** pushbutton.

11 Troubleshooting

This chapter describes how to identify faults on the MLG-2.

11.1 Response to faults



CAUTION

Cease operation if the cause of the malfunction has not been clearly identified.

Immediately put the machine out of operation if you cannot clearly identify the fault and if you cannot safely remedy the problem.

11.2 SICK support

If you cannot remedy the error with the help of the information provided in this chapter, please contact your respective SICK subsidiary.

11.3 LED indicators and error indicators

This section explains what the LED error indicators mean. The status indicators are described in a separate section [see "Display and operating elements", page 32](#).

LEDs on the front of the sender

Table 154: LED indicators on the sender

Yellow LED	Red LED	Green LED	Meaning
○	○	○	Supply voltage off or too low
○	○	●	Supply voltage on
☉ 1Hz	○	●	Test input active
○	●	○	Hardware error

LEDs on the front of the receiver

Table 155: LED indicators on the receiver

Yellow LED	Red LED	Green LED	Meaning
○	○	○	Supply voltage off or too low
○	○	●	Supply voltage on
●	○	●	Light path blocked (at least one beam blocked)
☉ 1Hz	○	●	Teach-in active
☉ 3 Hz	○	●	Contamination warning or alignment aid active and alignment poor
☉	☉	☉	"Find Me" function active If multiple MLG-2s are installed in one application, you can activate the "Find Me" function to identify a certain MLG-2.
○	☉ 10 Hz	○	Error occurred during teach-in, at least one beam blocked
○	●	○	Hardware error
●	●	○	Synchronization error
○	●	●	Short-circuit

LEDs on the fieldbus module

Table 156: LEDs on the fieldbus module

LED	Meaning
POWER	
●	Supply voltage on
○	Supply voltage off or too low
STATUS⁸⁾	
RUN	
● Green	Device has operational status
⦿ Green	Device in Stopped status
◐ Green	Device has pre-operational status
○ Off	No operating voltage
ERROR	
● Red	Busoff The CANopen master is isolated from the bus.
◐ Red	Detection of the baud rate or layer setting services is active
⦿ Red	Counter for the internal CAN controller has reached the warning limit for "error frames"
⦿ Red ⦿ Green	Error within the node guarding telegram or the heartbeat telegram
LINK/ACT	
●	Ethernet connection present
○	No Ethernet connection
◐ 1 Hz	Data is being received or sent

11.4 Advanced diagnostics on the MLG-2

The supplied SOPAS ET software contains advanced diagnostics options. These options allow you to further isolate the problem if the error situation is unclear or if there are availability issues. You can find detailed information:

- In the Status field (in the bottom left of the main screen)
- In the system boundaries display (minimum detectable object for the current configuration, minimum presence time, reproducibility, response time)

⁸⁾ The STATUS display consists of two LEDs. These are the RUN LED (green) and the ERROR LED (red) in accordance with the CANopen specifications.

12 Decommissioning

12.1 Disposal

Always dispose of serviceableness devices in compliance with local/national rules and regulations with respect to waste disposal.

**NOTE**

We would be pleased to be of assistance on the disposal of this device. Please contact us.

12.2 Returns

To enable efficient processing and allow us to determine the cause quickly, please include the following when making a return:

- Details of a contact person
- A description of the application
- A description of the fault that occurred

13 Technical data

13.1 Data sheet

General data

Table 157: MLG-2 data sheet – General data

Protection class	III (EN 61140)
Enclosure rating	IP 65 and IP 67 (EN 60529) ¹⁾
Ambient operating temperature	-30 ... +55 °C
Storage temperature	-40 ... +70 °C
Vibration resistance	5 g, 10 ... 55 Hz (EN 60068-2-6)
Shock resistance (EN 60068-2-27)	<ul style="list-style-type: none"> • Single shock • Continuous shock
Electromagnetic compatibility	According to EN 61000-6-2 Interference immunity for industrial environments and EN 61000-6-4 Emission standard for industrial environments
MTTF MTBF	15 years 15 years
Dimensions	see "Dimensional drawings", page 166
Weight	Sender + receiver approx. 2 kg/m + 0.1 kg
Materials	<ul style="list-style-type: none"> • Housing • Front screen
	<ul style="list-style-type: none"> • Aluminum, anodized • PMMA

¹⁾ Do not use light grids outdoors unless protected (condensation will form).

Electrical specifications (for 24 V DC and 25 °C ambient temperature)

Table 158: MLG-2 data sheet – Electrical specifications

Supply voltage V_S	24 V DC \pm 20%
Residual ripple (within V_S)	< 10%
Current consumption of sender	<ul style="list-style-type: none"> • Typical • Maximum • With 3x high-speed scan
Current consumption of receiver	<ul style="list-style-type: none"> • Typical • Maximum • In Dust- and sunlight-resistant operating mode, where a beam of 150 klx is sent to all receiver optics
Required overcurrent protection when using the following wire gages	<ul style="list-style-type: none"> • 5 A • 3 A • 2 A • 1 A • 0.8 A • 0.5 A
	<ul style="list-style-type: none"> • 40 mA + (0.1 mA \times number of beams) • <55 mA + (0.1 mA \times number of beams) • <100 mA + (0.1 mA \times number of beams)
	<ul style="list-style-type: none"> • 60 mA + (0.25 mA \times number of beams) • < 80 mA + (0.25 mA \times number of beams) • < 80 mA + (0.55 mA \times number of beams)

Output signal switching device

Table 159: MLG-2 data sheet – Switching outputs

Switching type	Push-pull
Logic level switching points <ul style="list-style-type: none"> HIGH LOW 	<ul style="list-style-type: none"> $V_S - 3\text{ V}$ $< 3\text{ V}$
Maximum output current per output	100 mA
Output load per output <ul style="list-style-type: none"> Capacitive Inductive 	<ul style="list-style-type: none"> 100 nF 1 H
Response time	see figure 143, page 163

Technical measurement data

Table 160: MLG-2 data sheet – Technical measurement specifications

Wavelength	850 nm
Ambient light immunity <ul style="list-style-type: none"> Standard operating mode Dust- and sunlight-resistant operating mode¹⁾ 	<ul style="list-style-type: none"> 150,000 lx (constant light, indirect) 150,000 lx (constant light, direct and indirect)
Minimum detectable object for devices with 5 mm, 10 mm, 20 mm, 25 mm, 30 mm, 50 mm beam separation <ul style="list-style-type: none"> With normal measurement accuracy With high measurement accuracy In Transparent operating mode Cross beam function 	<ul style="list-style-type: none"> Beam separation + 4 mm Beam separation Beam separation²⁾ $0.5 \times \text{beam separation} + 4\text{ mm}$
Minimum detectable object for devices with 2.5 mm beam separation <ul style="list-style-type: none"> With normal measurement accuracy With high measurement accuracy In Transparent operating mode Cross beam function 	<ul style="list-style-type: none"> Beam separation + 1 mm Beam separation Beam separation³⁾ $0.5 \times \text{beam separation} + 3.5\text{ mm}$
Beam separation	2.5 mm, 5 mm, 10 mm, 20 mm, 25 mm, 30 mm, 50 mm
Number of beams	6 ... 510
Detection height	130 ... 3140 mm
Limiting range	2.8 m / 7 m / 12 m depending on device type ⁴⁾
Operating range	2 m / 5 m / 8.5 m depending on device type ⁵⁾
Minimum sensing range <ul style="list-style-type: none"> With parallel-beam function With cross-beam function 	<ul style="list-style-type: none"> 0 mm 0.2 ... 1.20 m (see table 161, page 162)
Initialization time after switch-on	<3 s
Response time	see "Response time and minimum presence time without high-speed scan", page 163
Minimum presence time	see "Minimum detectable absorption", page 165

Cycle time	8 ... 48 µs per beam ⁶⁾
------------	------------------------------------

- 1) Only possible for devices with < 240 beams.
- 2) For opaque objects. For transparent objects + 4 mm
- 3) For opaque objects. For transparent objects + 1 mm
- 4) In Dust- and sunlight-resistant operating mode depending on device type.
- 5) In Dust- and sunlight-resistant operating mode: 3 m / 5 m depending on device type.
- 6) Depending on device version and operating mode.

Table 161: Minimum sensing range with cross-beam function

MLG-2 with sensing range	Beam separation						
	2.5 mm	5 mm	10 mm	20 mm	25 mm	30 mm	50 mm
2 m	0.20 m	-	-	-	-	-	-
5 m	-	0.11 m	0.22 m	0.44 m	0.55 m	0.66 m	1.10 m
8.5 m	-	0.12 m	0.24 m	0.48 m	0.60 m	0.72 m	1.20 m

13.2 Data sheet - fieldbus module

General data

Table 162: Fieldbus module data sheet – General data

Protection class	III (EN 61140)
Enclosure rating	IP 65 and IP 67 (EN 60529)
Ambient operating temperature	-30 ... +55 °C
Storage temperature	-40 ... +70 °C
Vibration resistance	5 g, 10 ... 55 Hz (EN 60068-2-6)
Shock resistance (EN 60068-2-27)	<ul style="list-style-type: none"> • Single shock • Continuous shock <ul style="list-style-type: none"> • 15 g, 11 ms • 10 g, 16 ms
Electromagnetic compatibility	According to EN 61000-6-2 Interference immunity for industrial environments and EN 61000-6-4 Emission standard for industrial environments
MTTF MTBF	15 years 15 years
Firmware version	See type label of device.
Dimensions	see "Dimensional drawing MLG-2 ProNet", page 166
Weight	350 g
Materials	<ul style="list-style-type: none"> • Housing <ul style="list-style-type: none"> • Zinc, painted

- 1) Do not use light grids outdoors unless protected (condensation will form)

Electrical specifications (for 24 V DC and 25 °C ambient temperature)

Table 163: Fieldbus module data sheet – Electrical specifications

Supply voltage V_S	24 V DC \pm 20%
Residual ripple (within V_S)	< 10%
Current consumption	<ul style="list-style-type: none"> • Typical • Maximum <ul style="list-style-type: none"> • 115 mA • < 160 mA

Required overcurrent protection when using the following wire gages	
<ul style="list-style-type: none"> • AWG 20/0.52 mm² • AWG 22/0.32 mm² • AWG 24/0.20 mm² • AWG 26/0.13 mm² • AWG 28/0.08 mm² • AWG 30/0.05 mm² 	<ul style="list-style-type: none"> • 5 A • 3 A • 2 A • 1 A • 0.8 A • 0.5 A

Ethernet interface

Table 164: Fieldbus module data sheet – Ethernet interface

Data transmission rate	100 Mbit/s
Default IP address	192.168.200.100
Subnet mask	255.255.255.0
Protocol	TCP/IP
Maximum length of cable	According to IEE802.3 (type 100 m)

CANopen interface

Table 165: Fieldbus module data sheet – CANopen interface

Data transmission rate	10 kbit/s, 20 kbit/s, 50 kbit/s, 125 kbit/s, 250 kbit/s, 500 kbit/s, 800 kbit/s, 1,000 kbit/s
------------------------	---

13.3 Diagrams

13.3.1 Response time and minimum presence time without high-speed scan

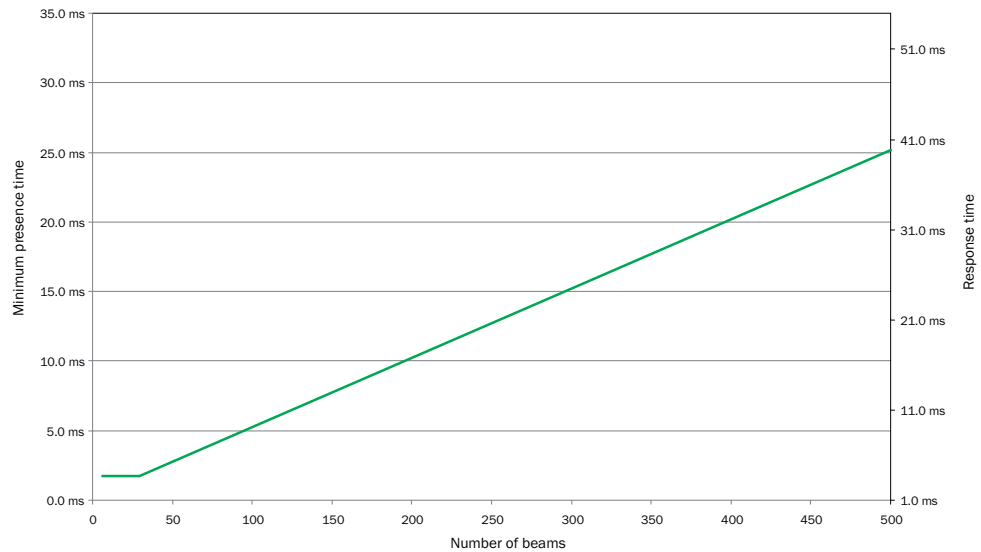

Figure 143: Graph, MLG-2 Pro response time and minimum presence time



NOTE

If the cross-beam function is configured, multiply the minimum presence time and the response time by 2.

13.3.2 Response time and minimum presence time during high-speed scan with 2,5 mm resolution

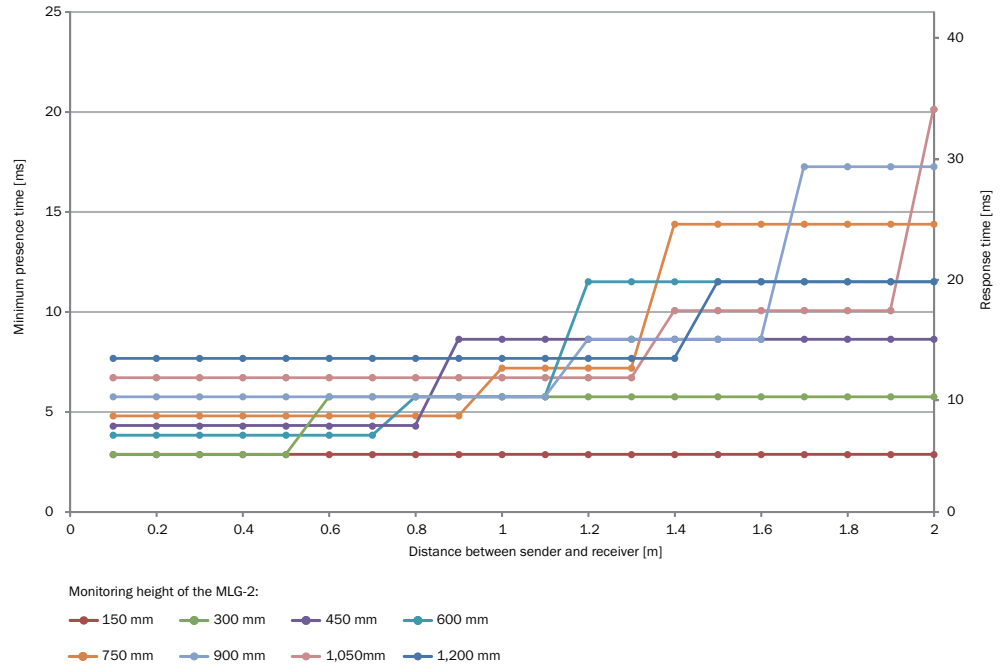

Figure 144: Response time and minimum presence time up to 2 m sensing range



NOTE

Only applies for the “High measurement accuracy” operating mode since only this operating mode can be set via the SDD, special for 2.5 mm raster devices.

13.3.3 Response time and minimum presence time during high-speed scan with up to 3.5 m sensing range

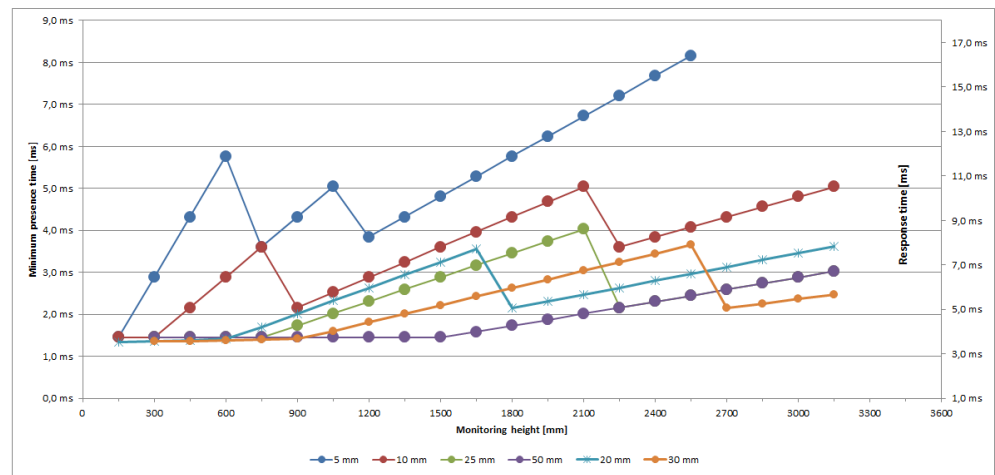

Figure 145: Response time and minimum presence time up to 3.5 m sensing range

13.3.4 Response time and minimum presence time during high-speed scan with up to 8.5 m sensing range

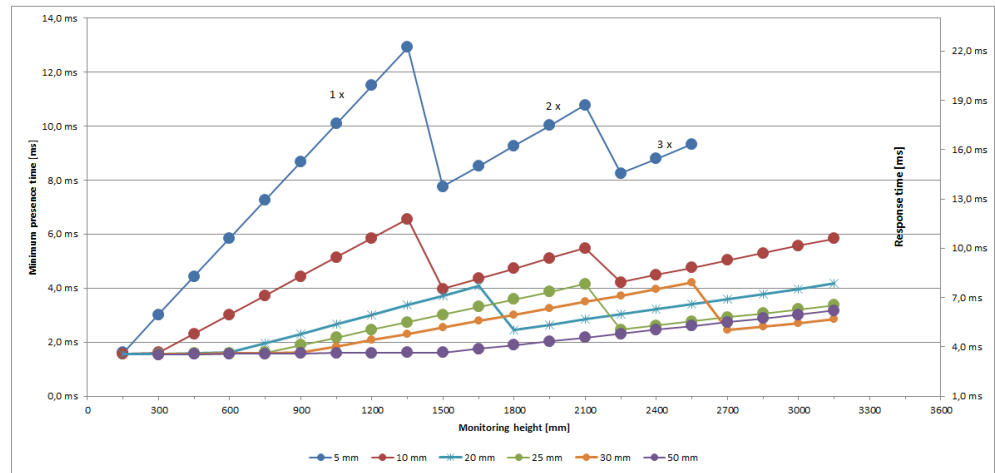

Figure 146: Response time and minimum presence time up to 8.5 m sensing range

13.3.5 Minimum detectable absorption

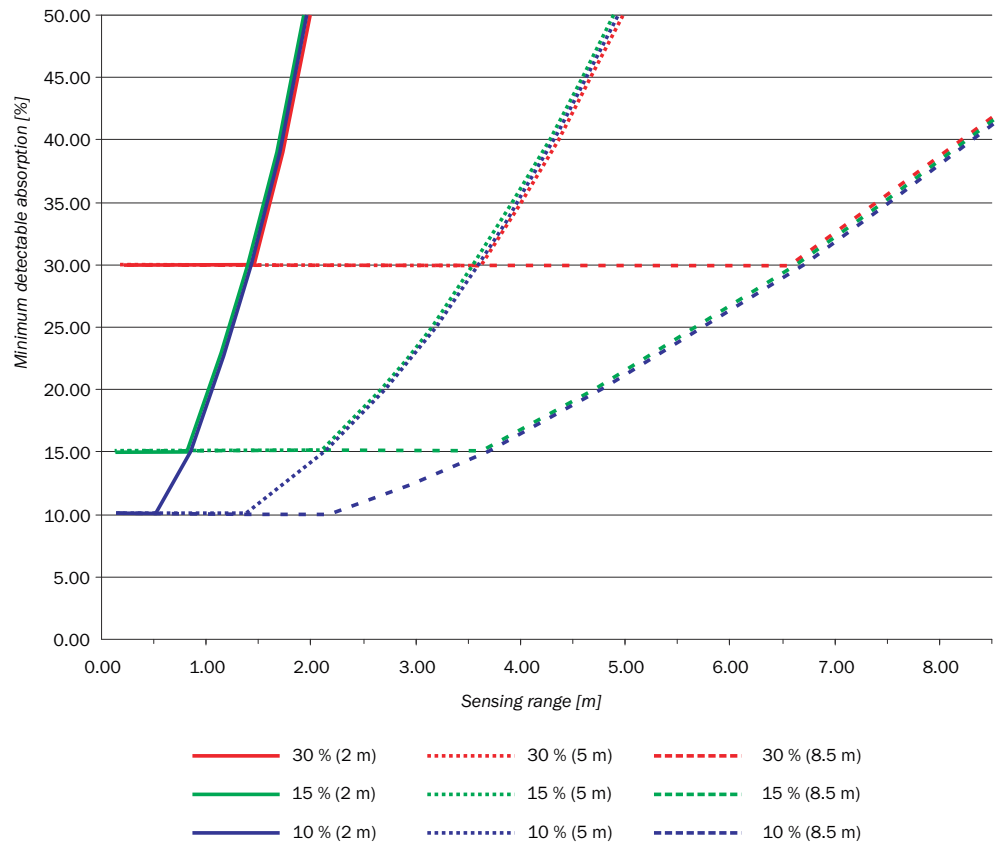

Figure 147: Minimum detectable absorption required for devices with 2 m, 5 m and 8.5 m sensing range



NOTE

The minimum detectable absorption which can be read from the diagram applies after the teach-in process with clean ambient conditions. The minimum detectable absorption increases with the level of contamination. Clean the front screens of the sender and receiver regularly, then perform a teach-in process.

13.4 Dimensional drawings

13.4.1 Dimensional drawing MLG-2 ProNet

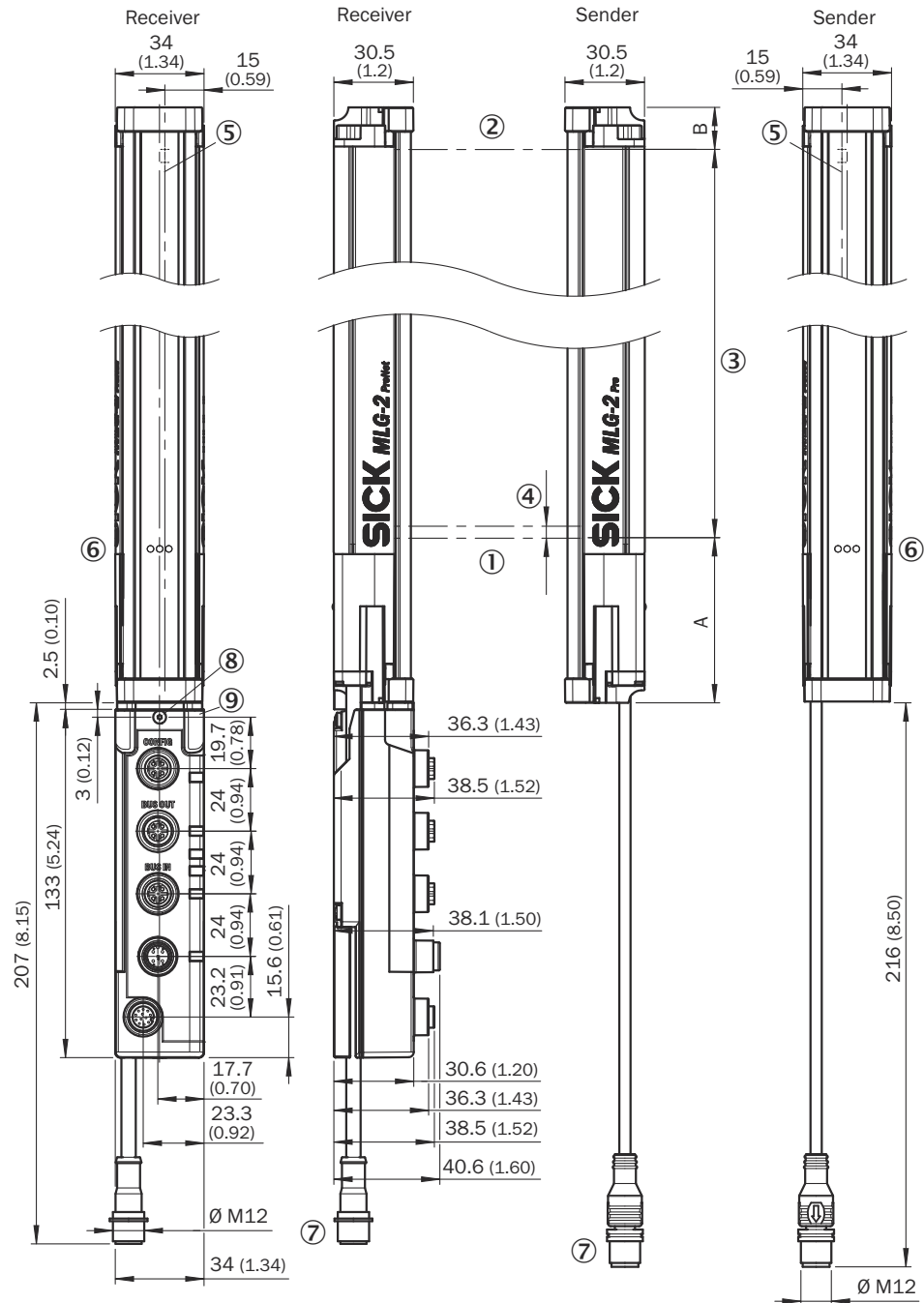

Figure 148: Dimensional drawing MLG-2 ProNet (mm)

① First light beam

- ② Last light beam
 - ③ Detection height (see table 166)
 - ④ Beam separation
 - ⑤ Optical axis
 - ⑥ Status indicator: green, yellow, red LEDs
 - ⑦ Connection
- A + B see table 167, page 168

Total height of the devices

Total height of the devices with 5, 10, 20, 25, 30 and 50 mm beam separation = A + ① + ④ + 16.1 mm (equates to ②).

Total height of the devices with 2.5 mm beam separation = A + ① + ④ + 17.15 mm (equates to ②).

13.4.2 Measurement tables

Table 166: Detection height (mm)/number of beams

	Type/beam separation						
	MLG02.../ 2.5 mm	MLG05.../ 5 mm	MLG10.../ 10 mm	MLG20.../ 20 mm	MLG25.../ 25 mm	MLG30.../ 30 mm	MLG50.../ 50 mm
Detection height [mm]/number of beams	145/59	145/30	140/15	140/8 ¹	-	-	-
	295/119	295/60	290/30	280/15 ²	275/12	270/10	250/6
	445/179	445/90	440/45	440/23 ¹	425/18	420/15	400/9
	595/239	595/120	590/60	580/30 ²	575/24	570/20	550/12
	745/299	745/150	740/75	740/38 ¹	725/30	720/25	700/15
	895/359	895/180	890/90	880/45 ²	875/36	870/30	850/18
	1045/419	1045/210	1040/105	1040/53 ¹	1025/42	1020/35	1000/21
	1195/479	1195/240	1190/120	1180/60 ²	1175/48	1170/40	1150/24
	-	1345/270	1340/135	1340/68 ¹	1325/54	1320/45	1300/27
	-	1495/300	1490/150	1480/75 ²	1475/60	1470/50	1450/30
	-	1645/330	1640/165	1640/83 ¹	1625/66	1620/55	1600/33
	-	1795/360	1790/180	1780/90 ²	1775/72	1770/60	1750/36
	-	1945/390	1940/195	1940/98 ¹	1925/78	1920/65	1900/39
	-	2095/420	2090/210	2080/105 ²	2075/84	2070/70	2050/42
	-	2245/450	2240/225	2240/113 ¹	2225/90	2220/75	2200/45
	-	2395/480	2390/240	2380/120 ²	2375/96	2370/80	2350/48
	-	2545/510	2540/255	2540/128 ¹	2525/102	2520/85	2500/51
	-	-	2690/270	2680/135 ²	2675/108	2670/90	2650/54
	-	-	2840/285	2840/143 ¹	2825/114	2820/95	2800/57
	-	-	2990/300	2980/150 ²	2975/120	2970/100	2950/60
-	-	3140/315	3140/158 ¹	3125/126	3120/105	3100/63	

¹ Distance from MLG-2 connection side to first beam = 68.3 mm.
² Distance from MLG-2 connection side to first beam = 78.3 mm.

Table 167: Distance from MLG-2 connection side to first beam

Beam separation	Distance from MLG-2 connection side to first beam (A)	Distance from MLG-2 connection side to last beam (B)
2.5 mm	62.25 mm	17.15 mm
5 mm	63.3 mm	16.1 mm
10 mm	68.3 mm	16.1 mm
20 mm	68.3 mm / 78.3 mm ¹	16.1 mm
25 mm	83.3 mm	16.1 mm
30 mm	88.3 mm	16.1 mm
50 mm	108.3 mm	16.1 mm

¹ see table 166.

13.4.3 Dimensional drawings for the MLG-2 fieldbus module

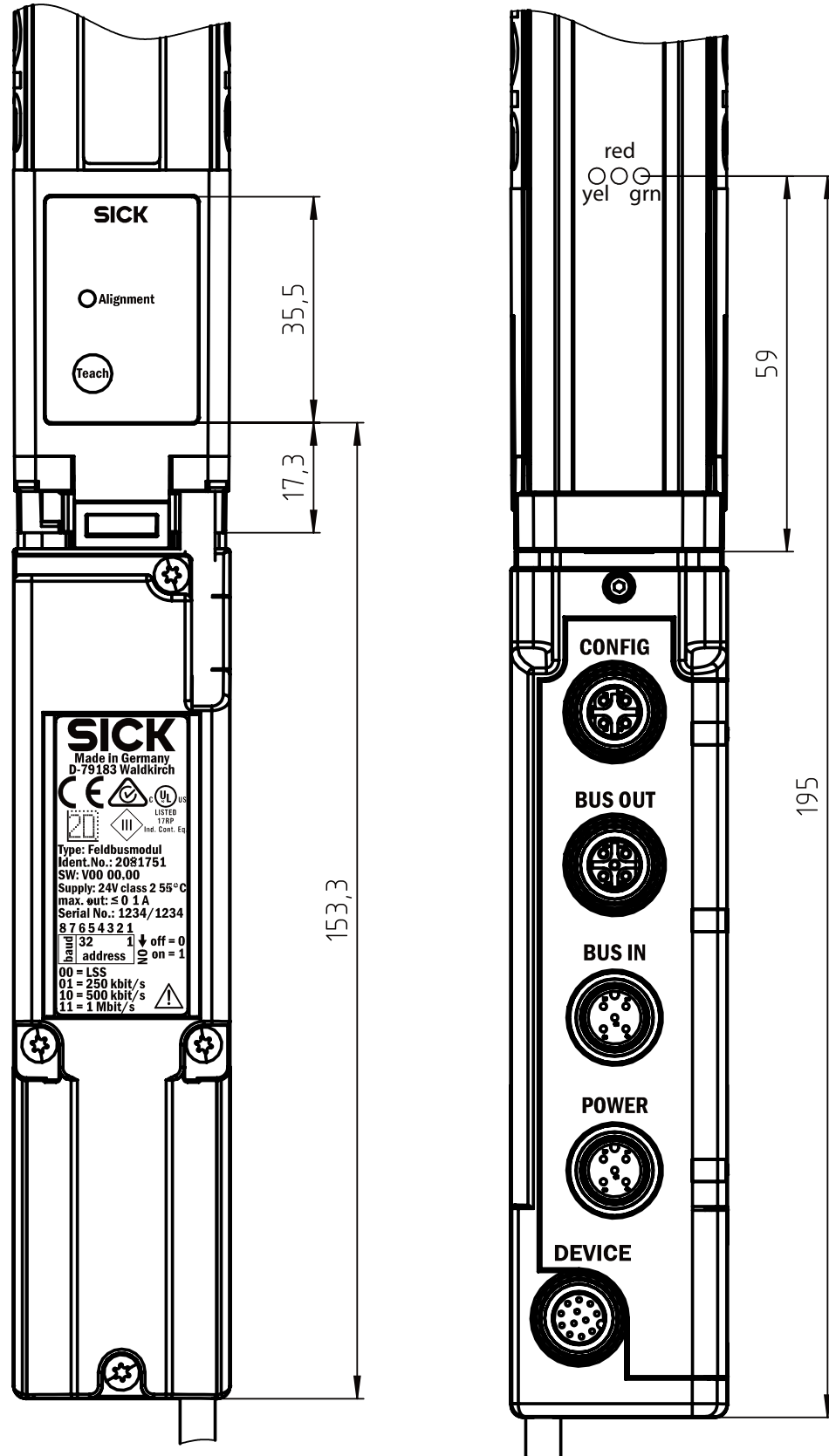

Figure 149: Dimensional drawing 1 MLG-2 fieldbus module

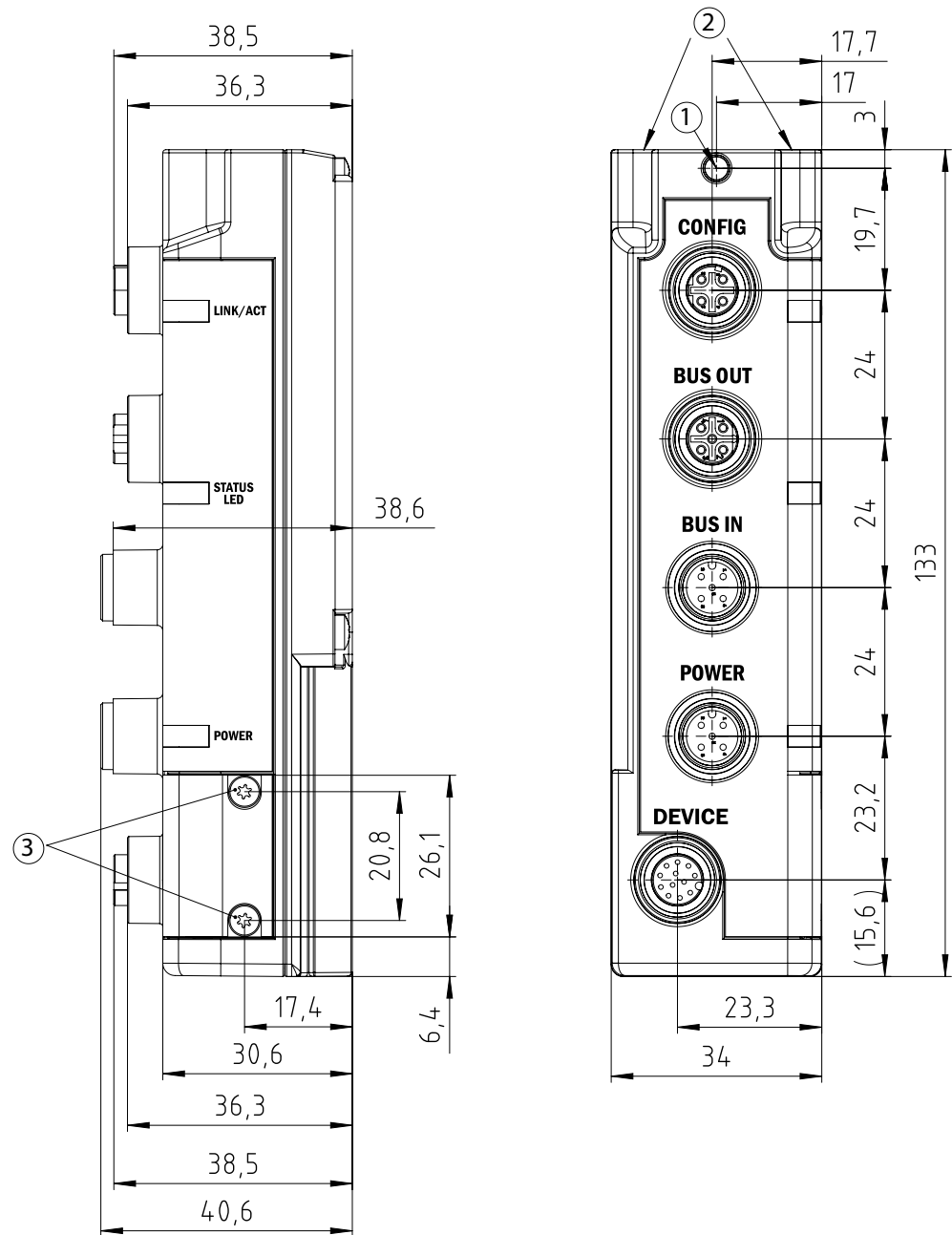

Figure 150: Dimensional drawing 2 MLG-2 fieldbus module

- ① Fieldbus module fixing screw
- ② Openings for mounting pins
- ③ DIP switch cover fixing screw

14 **Ordering information**

Ordering information for the MLG-2 can be found in the MLG-2 product information, SICK part number 8017054.

15 Accessories

15.1 Auxiliary equipment

Table 168: Equipment part numbers

Type	Description	Part no.
AR60	Laser alignment aid for various sensors, laser class 2 (IEC 60825). Do not look into the beam.	1015741
Adapter AR60	Adapter AR60 for MLG-2	4070854
Lens cloth	Cloth for cleaning the front screen	4003353
Plastic cleaner	Plastic cleaner and polish, anti-static, 0.5 liters	5600006

15.2 Mounting materials

Table 169: Mounting material part numbers

Type	Description	Part no.
BEF-1SHABP004	Mounting kit for replacement of swivel mount brackets 2019649 and 2019659 or side bracket 2019506 with the FlexFix bracket when using the bore holes provided	2071021
BEF-1SHABPKU4	FlexFix bracket, plastic	2066614
BEF-1SHABPKU4-SET2	Set with 4 × FlexFix bracket, plastic and 1 × mounting bracket	2083452
BEF-3SHABPKU2	QuickFix bracket, plastic	2066048
BEF-3SHABPKU2-SET1	Set with 6 × QuickFix bracket, plastic	2085604
BEF-WN-FBM-SET1	1 × mounting bracket and 1 × screw M5 × 6	2082322
BEF-WN-FBM-SET2	2 × mounting bracket and 3 × screw M5 × 6	2083323

Table 170: Sliding nut part numbers

Type	Description	Part no.
T-nuts	Sliding nut	4031411
Sliding nut	Sliding nut, M5	5305719
Sliding nuts	Sliding nut set, M5, 4 pieces	2017550
UH sliding nut	Sliding nut, item profile, M6	5305615

15.3 Connection materials

Table 171: T-distributor part numbers

Type	Description	Part no.
SBO-02G12-SM	T-distributor M12, 5-pin, male connector M12, 5-pin, straight, A-coded on 2 × female connector M12, 5-pin, straight, A-coded	6029305

Table 172: Part numbers for connecting cable with female connector

Type	Head A connection type	Head B connection type	Connecting cable	Part no.
DOL-1205-G05MAC	Female connector, M12, 5-pin, straight, shielded	Cable, loose cable ends	5 m, 5-wire	6036384

Type	Head A connection type	Head B connection type	Connecting cable	Part no.
DOL-1205-G02M	Female connector, M12, 5-pin, straight, unshielded	Cable, loose cable ends	2 m, 5-wire	6008899
DOL-1205-G05M			5 m, 5-wire	6009868
DOL-1205-G10M			10 m, 5-wire	6010544
DOL-1205-G15M			15 m, 5-wire	6029215

Table 173: Female connector part numbers

Type	Head A connection type	Head B connection type	Part no.
DOS-1205-G	Female connector, M12, 5-pin, straight, unshielded	Screw terminals	6009719

Table 174: Ethernet connecting cable part numbers (configuration)

Type	Head A connection type	Head B connection type	Connecting cable	Part no.
SSL-1204-G02ME	Male connector, M12, 4-pin, D-coded, shielded	Male connector, M12, 4-pin, D-coded	2 m, 4-wire	6034420
SSL-1204-G05ME			5 m, 4-wire	6034422
Connection cable (male connector-male connector)	Male connector, M12, 4-pin, straight, D-coded, shielded	Male connector, RJ-45, 8-pin, straight	5 m, 4-wire, AWG26	6034415
SSL-2J04-G02ME	Male connector, M12, 4-pin, straight, D-coded, shielded	Male connector, RJ-45, 8-pin, straight	2 m, 4-wire, AWG26	6034414

Table 175: CANopen connecting cable part numbers

Type	Head A connection type	Head B connection type	Connecting cable	Part no.
DSL-1205-G01MK	Female connector, M12, 5-pin, straight, A-coded	Male connector, M12, 5-pin, straight, A-coded	1 m, 5-wire	6021164
DSL-1205-G06MK			6 m, 5-wire, 0.34 mm ²	6028327
DOL-1205-G06MK	Female connector, M12, 5-pin, straight	Open cable ends	6 m, 5-wire, 0.75 mm ²	6028326
DOS-1205-GA	Female connector, M12, 5-pin, straight	Cable socket		6027534
STE-1205-GA	Male connector, M12, 5-pin, straight	Male cable connector		6028333
CAN male connector	Male connector, M12, 5-pin, straight	Male cable connector with terminator		6021167
LTG-2804-MW	Cable sold by meter, AL PT, shielded, PUR halogen-free, black			6028328

Table 176: Part number for MLG-2 connection cable to fieldbus module

Type	Head A connection type	Head B connection type	Connecting cable	Part no.
DSL-1212-G2M7AC	Female connector, M12, 12-pin, straight	Male connector, M12, 12-pin, straight	2.7 m, 12-wire, shielded, shielded, PUR, halogen-free	6056903

16 Annex

16.1 Conformities and certificates

You can obtain declarations of conformity, certificates and the current documentation for the product at www.sick.com. To do so, enter the product part number in the search field (part number: see the entry in the “P/N” or “Ident. no.” field on the type label).

16.2 Licenses

SICK uses open source software which is published by the rights holders under a free license. Among others, the following license types are used: GNU General Public License (GPL version 2, GPL version 3), GNU Lesser General Public License (LGPL), MIT license, zlib license and licenses derived from the BSD license.

This program is provided for general use without warranty of any kind. This warranty disclaimer also extends to the implicit assurance of marketability or suitability of the program for a particular purpose.

More details can be found in the GNU General Public License.

For license texts see www.sick.com/licensetexts.

License texts can be read out from the device using a web browser via the following URL: `<device ip>/license/COPYING`

Printed copies of the license texts are also available on request.

17 List of figures

1.	MLG-2 ProNet device components.....	15
2.	Detection area of the MLG-2.....	16
3.	Schematic depiction of available beam separations (mm).....	16
4.	Detection area with beams blanked.....	18
5.	Standard scan method.....	19
6.	Scan time in relation to the number of beams.....	19
7.	Cross-beam function.....	20
8.	High-speed scan.....	20
9.	Scan time in relation to the number of beams when using the high-speed scan..	20
10.	Minimum detectable object.....	21
11.	Minimum detectable object length.....	22
12.	Cross-beam function.....	23
13.	Minimum detectable object size with high measurement accuracy.....	24
14.	LEDs on the sender.....	32
15.	LEDs on the front and on the control panel.....	33
16.	Control panel on the rear side.....	33
17.	LEDs on the fieldbus module	34
18.	DIP switch on the fieldbus module.....	34
19.	Start and end detection.....	35
20.	Detection of transparent objects.....	35
21.	Detection of small objects.....	35
22.	Traffic applications.....	35
23.	Volume measurement.....	35
24.	Contour measurement.....	35
25.	Placement with light in opposite directions.....	36
26.	Distances when light is in the same direction.....	37
27.	Graph, distances when light is in the same direction.....	38
28.	Graph, distances when light is in the same direction (XZ).....	39
29.	Placement of two light grids at right angles.....	39
30.	Graph, minimum distance from reflective surfaces.....	40
31.	The sender and receiver are aligned incorrectly.....	41
32.	Mount QuickFix bracket to a profile frame.....	42
33.	QuickFix bracket for the fieldbus module.....	43
34.	Mounting the FlexFix bracket on a profile frame.....	44
35.	Inserting the MLG-2 in the FlexFix brackets.....	44
36.	Mounting bracket for the fieldbus module	45
37.	Mounting directions of the fieldbus module	46
38.	Turn the fieldbus module by 180°	46
39.	Mount the fieldbus module offset using the QuickFix bracket.....	47
40.	Mount the fieldbus module offset using the mounting bracket.....	47
41.	Fieldbus module connections.....	49
42.	Connection with T-distributor.....	52
43.	T-distributor of sender and fieldbus module.....	54
44.	Alignment with the QuickFix bracket.....	55
45.	Alignment with the FlexFix bracket.....	56
46.	Rotate the receiver once.....	56
47.	Control panel.....	57
48.	CANopen in the OSI model.....	58
49.	Example of a CANopen network in a line structure.....	59
50.	DIP switches 1 to 8 (illustrated as assembled).....	61
51.	Node ID and baud rate in SOPAS ET.....	61
52.	Example of a Receive SDO and a Transmit SDO.....	63
53.	Example for process data.....	64
54.	Beam function NBB.....	78

55. Beam function NBM.....	78
56. Beam function FBB.....	79
57. Beam function FBM.....	79
58. Beam function LBB.....	80
59. Beam function LBM.....	80
60. Beam function NCBB.....	81
61. Beam function NCBM.....	81
62. Beam function CBB.....	82
63. Beam function CBM.....	82
64. Beam function ODI.....	83
65. Beam function IDI.....	83
66. Beam status – Example 1.....	85
67. Beam status – Example 2.....	86
68. Example of the blanking of blocked beams.....	91
69. Example of blanking made beams.....	92
70. Bit-coded beam mask for an MLG-2, with 30 beams.....	92
71. Beam numbering.....	99
72. Device selection, operating mode and user level.....	109
73. SOPAS ET interface.....	110
74. Display of the system boundaries.....	110
75. Wizards.....	111
76. Display of the process quality.....	111
77. Basic functions and status of the output.....	112
78. Detection area – Simulation.....	112
79. Combining beams into zones.....	113
80. Using beams for object recognition.....	113
81. Using beams for height classification.....	114
82. Using beams to classify the object position.....	114
83. Blanking beams.....	115
84. Blanked beams.....	115
85. Rotating the image of the MLG-2.....	115
86. Image of the MLG-2 rotated.....	116
87. Expandable menus for configuration.....	116
88. Effect of the output configuration on the status indicator.....	117
89. Effects of the performance options on the system boundaries.....	117
90. I/O configuration.....	118
91. Beam numbering.....	119
92. Node ID and baud rate in SOPAS ET.....	120
93. Example representation of the outer dimension.....	121
94. Settings for height classification.....	122
95. Setting the height with the mouse.....	122
96. Beams highlighted in color in the simulation.....	123
97. Object recognition, static.....	124
98. Object recognition, dynamic.....	124
99. Object recognition with tolerance.....	125
100. Object detection/object width.....	126
101. Setting the object size with the mouse.....	126
102. Object detection of consecutive objects.....	127
103. Hole detection/hole size.....	128
104. Setting the hole size with the mouse.....	128
105. Detection of consecutive beams.....	129
106. Measurement of the outside dimension.....	130
107. Measurement of the inside dimension.....	130
108. Setting the outside dimension with the mouse.....	130
109. Classification of the object position – object center is greater than or equal to n beam.....	131

110. Classification of the object position – object center is smaller than or equal to n beam..... 131

111. Classification of the object position – object center is equal to n beam..... 132

112. Setting the object position with the mouse..... 132

113. Classification of the hole position – larger than or equal to hole center..... 133

114. Classification of the hole position – smaller than or equal to hole center.....133

115. Classification of the hole position – equal to hole center..... 133

116. Setting the hole position with the mouse..... 134

117. Examples of the effect of a configured minimum pulse width.....135

118. Measuring within zones..... 136

119. SOPAS ET beam window – Combining beams into zones..... 136

120. SOPAS ET – Assigning an application and zone to an output..... 137

121. Teach-in successful..... 138

122. Teach-in failed..... 138

123. Teach-in quality.....138

124. Example of the blanking of blocked beams.....139

125. Example of blanking made beams..... 139

126. Performance options for Standard operating mode and Dust- and sunlight-resistant operating mode.....140

127. Performance options for Transparent operating mode.....141

128. Illustration of the measuring object..... 143

129. Left: “Cross beam switching”, right: “Cross beam measuring”..... 143

130. SOAPS ET – Activating cross beam switching mode..... 144

131. SOAPS ET – Activating cross beam measuring mode.....145

132. SOAPS ET, beam window – “Cross beam measuring” display..... 145

133. SOPAS ET – “Blocked Beams Hold (BBH)” function..... 147

134. SOPAS ET – “Lost Beams Hold (LBH)” function..... 148

135. Add simulation object..... 149

136. Determine the shape of the simulation object.....149

137. Determine the size of the simulation object.....149

138. Start simulation..... 150

139. Simulation object in Simulation area..... 150

140. Beam status.....150

141. Function programming..... 152

142. Interface of the integrated web server.....155

143. Graph, MLG-2 Pro response time and minimum presence time..... 163

144. Response time and minimum presence time up to 2 m sensing range.....164

145. Response time and minimum presence time up to 3.5 m sensing range..... 164

146. Response time and minimum presence time up to 8.5 m sensing range..... 165

147. Minimum detectable absorption required for devices with 2 m, 5 m and 8.5 m sensing range..... 165

148. Dimensional drawing MLG-2 ProNet (mm)..... 166

149. Dimensional drawing 1 MLG-2 fieldbus module..... 169

150. Dimensional drawing 2 MLG-2 fieldbus module..... 170

18 List of tables

1.	Authorized personnel.....	10
2.	Example of an MLG-2 ProNet type code.....	12
3.	Meaning of the positions in the type code.....	12
4.	Monitoring height [mm].....	13
5.	Sensing range and minimum detectable object length.....	13
6.	Preconfiguration of MLG-2 ProNet with fieldbus version C.....	14
7.	Maximum monitoring heights.....	17
8.	Limiting range.....	17
9.	Minimum detectable object in relation to the beam separation of the MLG-2.....	21
10.	Minimum detectable object length with the MLG-2.....	22
11.	Minimum detectable object with cross-beam function on the MLG-2.....	23
12.	Minimum detectable object size with high measurement accuracy.....	24
13.	Minimum detectable object length with high measurement accuracy.....	24
14.	Functions available for or during teach-in.....	27
15.	Functions available for operating modes and performance options.....	27
16.	Configurable measuring and diagnostic functions for switching output Q1.....	28
17.	Auxiliary resources and diagnostic options.....	29
18.	System information.....	29
19.	Beam evaluation.....	29
20.	Settings for the interfaces.....	30
21.	Settings for SOPAS ET.....	30
22.	Available process data.....	30
23.	Application examples for the MLG-2.....	35
24.	Overcurrent protection.....	48
25.	Pin assignment, CONFIG connection of the fieldbus module.....	49
26.	Pin assignment, BUS OUT connection of the fieldbus module.....	50
27.	Pin assignment, BUS IN connection of the fieldbus module.....	50
28.	Pin assignment, POWER connection of the fieldbus module.....	50
29.	Pin assignment, sender connection.....	51
30.	Pin assignment, I/O connection of the T-distributor.....	54
31.	Status of the CANopen state machine.....	59
32.	Maximum length of cable.....	60
33.	Node ID with DIP switches.....	61
34.	Baud rate with DIP switches.....	61
35.	Service data format.....	62
36.	Process data format.....	63
37.	Example for process data.....	64
38.	Access and data type nomenclature.....	64
39.	Standard objects.....	65
40.	Objects with process data.....	65
41.	Objects for the teach-in.....	66
42.	Objects for definition of operating mode/performance options.....	67
43.	Objects with auxiliary resources and diagnostic options.....	67
44.	Objects with system information.....	67
45.	Objects with beam evaluation.....	67
46.	Compatibility objects with the MLG predecessor version.....	68
47.	1000h – Device type.....	68
48.	1001h – Error register.....	68
49.	Error register – Stored in 8 bit.....	69
50.	1005h – COB-ID SYNC message.....	69
51.	1005h – Details.....	69
52.	1008h – Device name.....	69
53.	1009h – Hardware version number.....	69
54.	100Ah – Software version number.....	69

55.	100Ch - Node guarding – Guard time.....	70
56.	100Dh - Node guarding – Life time factor.....	70
57.	1014h – COB-ID emergency message.....	70
58.	Emergency messages.....	70
59.	1015h – Emergency inhibition time.....	71
60.	1016h – Consumer heartbeat time.....	71
61.	1016h – Details.....	71
62.	1017h – Producer heartbeat time.....	72
63.	1018h – Identity object.....	72
64.	Transmission types.....	72
65.	1400h to 1401h.....	74
66.	1600h – Mapping configured at the factory.....	74
67.	1601h – mapping configured at the factory.....	75
68.	Mapping.....	75
69.	1800h to 1809h.....	75
70.	1A00h – mapping configured at the factory.....	76
71.	1A01h – mapping configured at the factory.....	76
72.	1A02 to 1A09h – Mapping configured at the factory.....	77
73.	Mapping.....	77
74.	Beam functions.....	77
75.	NBB.....	77
76.	NBM.....	78
77.	FBB.....	78
78.	FBM.....	79
79.	LBB.....	80
80.	LBM.....	80
81.	NCBB.....	81
82.	NCBM.....	81
83.	CBB.....	82
84.	CBM.....	82
85.	ODI.....	82
86.	IDI.....	83
87.	QS – Switching output status.....	83
88.	SYS – System status.....	84
89.	Details of the system status.....	84
90.	QoR – Quality of Run (process quality).....	84
91.	QoT – Quality of Teach (teach-in quality).....	84
92.	Run-length code.....	85
93.	Example run-length code with 30 beams.....	85
94.	Example run-length code with the first beam blocked.....	86
95.	Beam status.....	86
96.	Beam functions for Zone measuring.....	87
97.	User-defined beam functions.....	88
98.	Teach-in.....	89
99.	Teach-in result.....	90
100.	Teach-in result – Stored in 8 bit.....	90
101.	Teach-in required.....	90
102.	Teach-in with blanking.....	90
103.	Blank blocked beams.....	91
104.	Blanking beams made.....	91
105.	Beam mask.....	92
106.	Operating mode.....	93
107.	Performance options.....	93
108.	Minimum detectable absorption.....	94
109.	Configuration Q1.....	94
110.	Byte sequence of 2263h.....	94
111.	Selectable beam functions.....	95

112. Energy saving mode.....	97
113. Switch-off delay.....	97
114. Alignment aid.....	97
115. Values for alignment aid.....	98
116. “Find Me” function.....	98
117. Pushbutton lock.....	98
118. Beam numbering.....	98
119. Cloning upload.....	99
120. Cloning download.....	99
121. Cloning status.....	100
122. Device name.....	100
123. Manufacturer name.....	100
124. Part number.....	100
125. Serial number.....	100
126. Product text.....	101
127. Mounting location.....	101
128. Device characteristics.....	101
129. Hardware revision.....	101
130. Firmware version	102
131. Zone measuring.....	102
132. Cross beam measuring.....	102
133. Evaluation mode.....	103
134. Control.....	104
135. Details.....	104
136. Beam status with 8-bit length.....	105
137. Beam functions with 8-bit length.....	105
138. NBB with 8-bit length.....	105
139. NBM with 8-bit length.....	105
140. FBB with 8-bit length.....	105
141. FBM with 8-bit length.....	105
142. LBB with 8-bit length.....	105
143. LBM with 8-bit length.....	106
144. NCBB with 8-bit length.....	106
145. NCBM with 8-bit length.....	106
146. CBB with 8-bit length.....	106
147. CBM with 8-bit length.....	106
148. ODI with 8-bit length.....	106
149. IDI with 8-bit length.....	106
150. System status with 8-bit length.....	106
151. Details of the system status with 8-bit length.....	107
152. Status of the switching output and the virtual switching outputs with 8-bit length	107
153. Beam functions for preliminary evaluation.....	153
154. LED indicators on the sender.....	157
155. LED indicators on the receiver.....	157
156. LEDs on the fieldbus module.....	158
157. MLG-2 data sheet – General data.....	160
158. MLG-2 data sheet – Electrical specifications.....	160
159. MLG-2 data sheet – Switching outputs.....	161
160. MLG-2 data sheet – Technical measurement specifications.....	161
161. Minimum sensing range with cross-beam function.....	162
162. Fieldbus module data sheet – General data.....	162
163. Fieldbus module data sheet – Electrical specifications.....	162
164. Fieldbus module data sheet – Ethernet interface.....	163
165. Fieldbus module data sheet – CANopen interface.....	163
166. Detection height (mm)/number of beams.....	167
167. Distance from MLG-2 connection side to first beam.....	168

168. Equipment part numbers.....172
169. Mounting material part numbers..... 172
170. Sliding nut part numbers..... 172
171. T-distributor part numbers.....172
172. Part numbers for connecting cable with female connector..... 172
173. Female connector part numbers.....173
174. Ethernet connecting cable part numbers (configuration)..... 173
175. CANopen connecting cable part numbers.....173
176. Part number for MLG-2 connection cable to fieldbus module..... 174

Australia

Phone +61 (3) 9457 0600
1800 33 48 02 – tollfree
E-Mail sales@sick.com.au

Austria

Phone +43 (0) 2236 62288-0
E-Mail office@sick.at

Belgium/Luxembourg

Phone +32 (0) 2 466 55 66
E-Mail info@sick.be

Brazil

Phone +55 11 3215-4900
E-Mail comercial@sick.com.br

Canada

Phone +1 905.771.1444
E-Mail cs.canada@sick.com

Czech Republic

Phone +420 234 719 500
E-Mail sick@sick.cz

Chile

Phone +56 (2) 2274 7430
E-Mail chile@sick.com

China

Phone +86 20 2882 3600
E-Mail info.china@sick.net.cn

Denmark

Phone +45 45 82 64 00
E-Mail sick@sick.dk

Finland

Phone +358-9-25 15 800
E-Mail sick@sick.fi

France

Phone +33 1 64 62 35 00
E-Mail info@sick.fr

Germany

Phone +49 (0) 2 11 53 010
E-Mail info@sick.de

Greece

Phone +30 210 6825100
E-Mail office@sick.com.gr

Hong Kong

Phone +852 2153 6300
E-Mail ghk@sick.com.hk

Hungary

Phone +36 1 371 2680
E-Mail ertekesites@sick.hu

India

Phone +91-22-6119 8900
E-Mail info@sick-india.com

Israel

Phone +972 97110 11
E-Mail info@sick-sensors.com

Italy

Phone +39 02 27 43 41
E-Mail info@sick.it

Japan

Phone +81 3 5309 2112
E-Mail support@sick.jp

Malaysia

Phone +603-8080 7425
E-Mail enquiry.my@sick.com

Mexico

Phone +52 (472) 748 9451
E-Mail mexico@sick.com

Netherlands

Phone +31 (0) 30 229 25 44
E-Mail info@sick.nl

New Zealand

Phone +64 9 415 0459
0800 222 278 – tollfree
E-Mail sales@sick.co.nz

Norway

Phone +47 67 81 50 00
E-Mail sick@sick.no

Poland

Phone +48 22 539 41 00
E-Mail info@sick.pl

Romania

Phone +40 356-17 11 20
E-Mail office@sick.ro

Russia

Phone +7 495 283 09 90
E-Mail info@sick.ru

Singapore

Phone +65 6744 3732
E-Mail sales.gsg@sick.com

Slovakia

Phone +421 482 901 201
E-Mail mail@sick-sk.sk

Slovenia

Phone +386 591 78849
E-Mail office@sick.si

South Africa

Phone +27 10 060 0550
E-Mail info@sickautomation.co.za

South Korea

Phone +82 2 786 6321/4
E-Mail infokorea@sick.com

Spain

Phone +34 93 480 31 00
E-Mail info@sick.es

Sweden

Phone +46 10 110 10 00
E-Mail info@sick.se

Switzerland

Phone +41 41 619 29 39
E-Mail contact@sick.ch

Taiwan

Phone +886-2-2375-6288
E-Mail sales@sick.com.tw

Thailand

Phone +66 2 645 0009
E-Mail marcom.th@sick.com

Turkey

Phone +90 (216) 528 50 00
E-Mail info@sick.com.tr

United Arab Emirates

Phone +971 (0) 4 88 65 878
E-Mail contact@sick.ae

United Kingdom

Phone +44 (0)17278 31121
E-Mail info@sick.co.uk

USA

Phone +1 800.325.7425
E-Mail info@sick.com

Vietnam

Phone +65 6744 3732
E-Mail sales.gsg@sick.com

Detailed addresses and further locations at www.sick.com