

# EDM35-2VF0A024A

EDS/EDM35

MOTOR FEEDBACK SYSTEMS

**SICK**  
Sensor Intelligence.

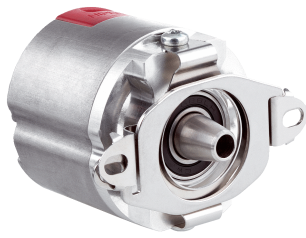

Illustration may differ



### Ordering information

Type	Part no.
EDM35-2VF0A024A	1106851

Other models and accessories → [www.sick.com/EDS\\_EDM35](http://www.sick.com/EDS_EDM35)

### Detailed technical data

#### Safety-related parameters

<b>Safety integrity level</b>	SIL 2 (IEC 61508), SILCL3 (IEC 62061) <sup>1)</sup>
<b>Category</b>	3 (EN ISO 13849-1:2015)
<b>Systematic suitability</b>	SC 3 (IEC61508)
<b>Test rate</b>	24 h
<b>Maximum demand rate</b>	216 µs
<b>Performance level</b>	PL d (EN ISO 13849-1:2015)
<b>Basis for safety function</b>	Safe singleturn absolute position
<b>Safety-related resolution</b>	13 bits
<b>Maximum difference between Safe Position 1 and Safe Position 2</b>	3 increments
<b>PFH<sub>D</sub>: Probability of dangerous failure per hour</b>	31.0 x 10 <sup>-9</sup> <sup>2)</sup>
<b>T<sub>M</sub> (mission time)</b>	20 years
<b>Safety-related accuracy</b>	0.135° <sup>3)</sup>

<sup>1)</sup> For more detailed information on the exact configuration of your machine/unit, please consult your relevant SICK branch office.

<sup>2)</sup> At 60 °C ambient temperature.

<sup>3)</sup> The safety-related accuracy specifies the maximum position error limit with which the safety functions can be supported. This results from the safety-related resolution: (360° / 13 bit = 0.045°). The accuracy to be used for project planning results from the maximum difference between Safe Position 1 and Safe Position 2. Thus the following relationship exists (safety-related accuracy = number of increments difference between Safe Position 1 and Safe Position 2 \* 0.045).

#### Performance

<b>Position</b>	
Resolution per revolution	24 bit
System accuracy	± 25 " <sup>1)</sup>
Signal noise (σ)	± 1 " <sup>2)</sup>
Number of the absolute ascertainable revolutions	4,096
Available memory area	8,192 Byte

<sup>1)</sup> In accordance with DIN ISO 1319-1, position of the upper and lower error limit depends on the installation situation, specified value refers to a symmetrical position, i.e. deviation in upper and lower direction is the same.

<sup>2)</sup> Repeatability standard deviation in accordance with DIN 1319-1:1995.

## Interfaces

<b>Code sequence</b>	Increasing, when turning the shaft For clockwise rotation, looking in direction "A" (see dimensional drawing)
<b>Communication interface</b>	HIPERFACE DSL®
<b>Initialization time</b>	≤ 500 ms <sup>1)</sup>
<b>Measurement external temperature resistance</b>	32-bit value, without prefix (1 Ω) 0 ... 209.600 Ω <sup>2)</sup>

<sup>1)</sup> From reaching a permitted operating voltage.

<sup>2)</sup> Without sensor tolerance; at -40 °C ... +160 °C: NTC +2K; PTC+3K (KTY84-130/PT1000). For additional conversion function of PT1000 to KTY84/130, see technical description.

## Electrical data

<b>Connection type</b>	Male connector, 8-pin
<b>Supply voltage</b>	7 V ... 12 V
<b>Warm-up time voltage ramp</b>	Max. 180 ms <sup>1)</sup>
<b>Current consumption</b>	≤ 150 mA <sup>2)</sup>
<b>Compatible with sHub®</b>	✓

<sup>1)</sup> Duration of voltage ramp between 0 and 7.0 V.

<sup>2)</sup> Current rating applies when using interface circuit suggestions as shown in HIPERFACE DSL® manual (8017595).

## Mechanical data

<b>Shaft version</b>	Tapered shaft
<b>Dimensions</b>	See dimensional drawing
<b>Weight</b>	≤ 100 g
<b>Moment of inertia of the rotor</b>	5 gcm <sup>2</sup>
<b>Operating speed</b>	≤ 9,000 min <sup>-1</sup>
<b>Angular acceleration</b>	≤ 250,000 rad/s <sup>2</sup>
<b>Start up torque</b>	≤ 0.6 Ncm, +20 °C
<b>Permissible movement static</b>	± 1 mm axial <sup>1)</sup>
<b>Permissible movement dynamic</b>	± 0.025 mm radial <sup>2)</sup>
<b>Life of ball bearings</b>	50,000 h at 6,000 min <sup>-1</sup> (at a flange temperature of 70 °C)

<sup>1)</sup> Temperature expansion, mechanical attachment.

<sup>2)</sup> For SIL2 version.

## Ambient data

<b>Operating temperature range</b>	-40 °C ... +115 °C <sup>1)</sup>
<b>Storage temperature range</b>	-40 °C ... +125 °C, without package
<b>Relative humidity/condensation</b>	90 %, Condensation not permitted
<b>Resistance to shocks</b>	100 g, 6 ms (according to EN 60068-2-27)
<b>Frequency range of resistance to vibrations</b>	50 g, 10 Hz ... 2,000 Hz (EN 60068-2-6)
<b>EMC</b>	According to EN 61000-6-2: 2016, EN 61000-6-4: 2006, IEC 6100-6-7: 2014 <sup>2)</sup>
<b>Enclosure rating</b>	IP40, When cover is closed and mating connector is attached (IEC 60529-1)

<sup>1)</sup> Given typical thermal connection between motor flange and encoder stator coupling. The max. internal sensor temperature may not exceed 125 °C.

<sup>2)</sup> According to the listed standards, EMC is guaranteed if the motor feedback system with mating connector inserted is connected to the central grounding point of the motor controller via a cable shield. If other shielding concepts are used, users must perform their own tests. Class A device.

### Classifications

<b>ECLASS 5.0</b>	27270590
<b>ECLASS 5.1.4</b>	27270590
<b>ECLASS 6.0</b>	27270590
<b>ECLASS 6.2</b>	27270590
<b>ECLASS 7.0</b>	27270590
<b>ECLASS 8.0</b>	27270590
<b>ECLASS 8.1</b>	27270590
<b>ECLASS 9.0</b>	27270590
<b>ECLASS 10.0</b>	27273805
<b>ECLASS 11.0</b>	27273901
<b>ECLASS 12.0</b>	27273901
<b>ETIM 5.0</b>	EC001486
<b>ETIM 6.0</b>	EC001486
<b>ETIM 7.0</b>	EC001486
<b>ETIM 8.0</b>	EC001486
<b>UNSPSC 16.0901</b>	41112113

### Dimensional drawing (Dimensions in mm (inch))

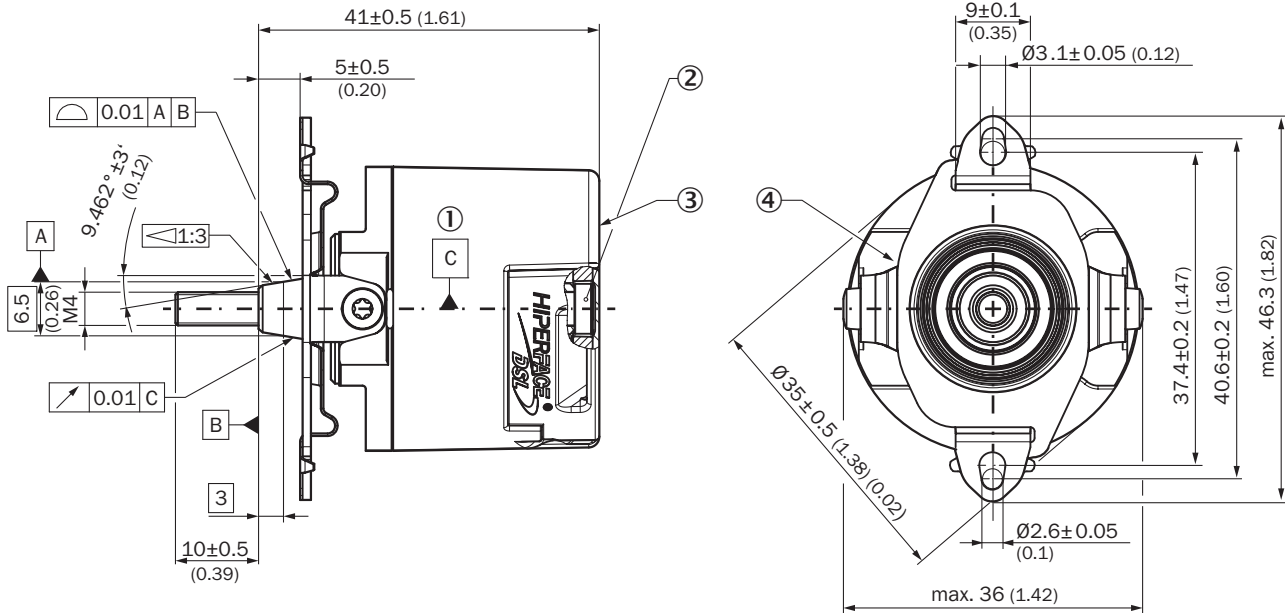

- ① Bearing of the encoder shaft
- ② Torx 15 cylinder screw
- ③ Measuring point for vibrations
- ④ Measuring point for operating temperature

### Attachment specifications

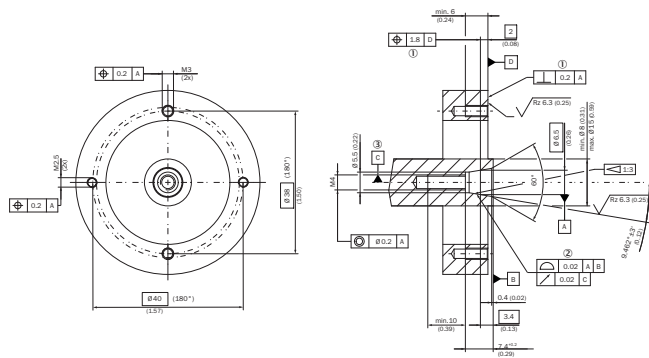

- ① Permanently
- ② Dynamic
- ③ Bearing of the drive shaft

### PIN assignment

Supply/Communication pin assignment

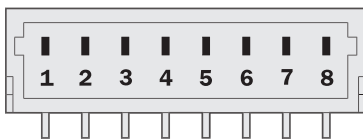

V connection type

PIN	Signal	Explanation
1	+U <sub>S</sub>	Supply
2	GND	Ground connection
3	DSL-	DSL negative
4	DSL+	DSL positive
5	RxD+	Receiver data positive
6	RxD-	Receiver data negative
7	TxD-	Sender data negative
8	TxD+	Sender data positive

Recommended mating connector: JST (GHR-08V-S)

### Diagrams

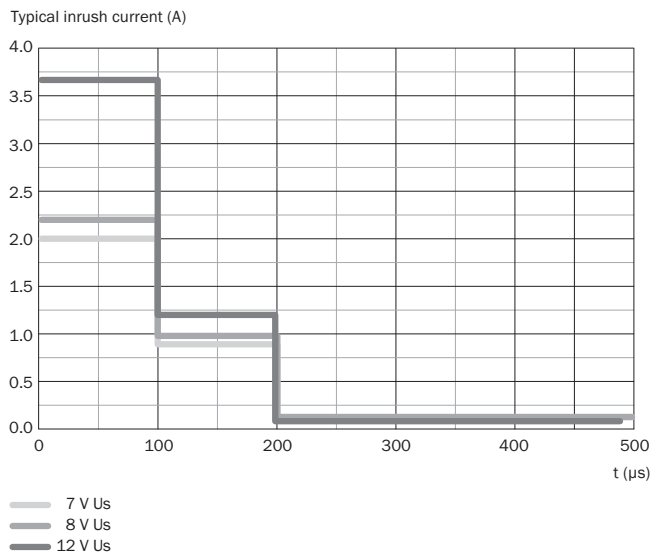

### Recommended accessories

Other models and accessories → [www.sick.com/EDS\\_EDM35](http://www.sick.com/EDS_EDM35)

Brief description	Type	Part no.
Spare parts		
EDM35 cover set, 10 pcs	BEF-CAP-EDM-010	2139997
EDM35 cover set, 40 pcs	BEF-CAP-EDM-040	2139999

## SICK AT A GLANCE

SICK is one of the leading manufacturers of intelligent sensors and sensor solutions for industrial applications. A unique range of products and services creates the perfect basis for controlling processes securely and efficiently, protecting individuals from accidents and preventing damage to the environment.

We have extensive experience in a wide range of industries and understand their processes and requirements. With intelligent sensors, we can deliver exactly what our customers need. In application centers in Europe, Asia and North America, system solutions are tested and optimized in accordance with customer specifications. All this makes us a reliable supplier and development partner.

Comprehensive services complete our offering: SICK LifeTime Services provide support throughout the machine life cycle and ensure safety and productivity.

For us, that is “Sensor Intelligence.”

## WORLDWIDE PRESENCE:

Contacts and other locations –[www.sick.com](http://www.sick.com)