

# EDM35-0VF0A024A

sHub

MOTOR FEEDBACK SYSTEMS

**SICK**  
Sensor Intelligence.

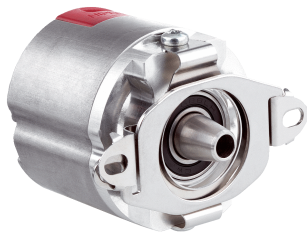

Illustration may differ



## Ordering information

Type	Part no.
EDM35-0VF0A024A	1106846

Other models and accessories → [www.sick.com/sHub](http://www.sick.com/sHub)

## Detailed technical data

### Performance

Position		
Resolution per revolution	24 bit	
System accuracy	$\pm 25''^{1)}$	
Signal noise ( $\sigma$ )	$\pm 1''^{2)}$	
Number of the absolute ascertainable revolutions	4,096	

<sup>1)</sup> In accordance with DIN ISO 1319-1, position of the upper and lower error limit depends on the installation situation, specified value refers to a symmetrical position, i.e. deviation in upper and lower direction is the same.

<sup>2)</sup> Repeatability standard deviation in accordance with DIN 1319-1:1995.

### Interfaces

<b>Code sequence</b>	Increasing, when turning the shaft For clockwise rotation, looking in direction "A" (see dimensional drawing)
<b>Communication interface</b>	HIPERFACE DSL <sup>®</sup>
<b>Initialization time</b>	$\leq 500 \text{ ms}^{1)}$
<b>Measurement external temperature resistance</b>	32-bit value, without prefix (1 $\Omega$ ) 0 ... 209.600 $\Omega^{2)}$

<sup>1)</sup> From reaching a permitted operating voltage.

<sup>2)</sup> Without sensor tolerance; at  $-40 \text{ }^{\circ}\text{C}$  ...  $+160 \text{ }^{\circ}\text{C}$ : NTC +2K; PTC+3K (KTY84-130/PT1000). For additional conversion function of PT1000 to KTY84/130, see technical description.

### Electrical data

<b>Supply voltage</b>	7 V ... 12 V
<b>Warm-up time voltage ramp</b>	Max. 180 ms <sup>1)</sup>
<b>Current consumption</b>	$\leq 150 \text{ mA}^{2)}$
<b>Compatible with sHub<sup>®</sup></b>	✓

<sup>1)</sup> Duration of voltage ramp between 0 and 7.0 V.

<sup>2)</sup> Current rating applies when using interface circuit suggestions as shown in HIPERFACE DSL<sup>®</sup> manual (8017595).

### Mechanical data

<b>Shaft version</b>	Tapered shaft
----------------------	---------------

<sup>1)</sup> Temperature expansion, mechanical attachment.

<b>Dimensions</b>	See dimensional drawing
<b>Weight</b>	≤ 100 g
<b>Moment of inertia of the rotor</b>	5 gcm <sup>2</sup>
<b>Operating speed</b>	≤ 9,000 min <sup>-1</sup>
<b>Angular acceleration</b>	≤ 250,000 rad/s <sup>2</sup>
<b>Start up torque</b>	≤ 0.6 Ncm, +20 °C
<b>Permissible movement static</b>	± 1 mm axial <sup>1)</sup>
<b>Permissible movement dynamic</b>	± 0.1 mm radial
<b>Life of ball bearings</b>	50,000 h at 6,000 min <sup>-1</sup> (at a flange temperature of 70 °C)

<sup>1)</sup> Temperature expansion, mechanical attachment.

### Ambient data

<b>Storage temperature range</b>	-40 °C ... +125 °C, without package
<b>Relative humidity/condensation</b>	90 %, Condensation not permitted
<b>Resistance to shocks</b>	100 g, 6 ms (according to EN 60068-2-27)
<b>Frequency range of resistance to vibrations</b>	50 g, 10 Hz ... 2,000 Hz (EN 60068-2-6)
<b>EMC</b>	According to EN 61000-6-2, EN 61000-6-4 and IEC 61326-3 <sup>1)</sup>
<b>Enclosure rating</b>	IP40, When cover is closed and mating connector is attached (IEC 60529-1)

<sup>1)</sup> According to the listed standards, EMC is guaranteed if the motor feedback system with mating connector inserted is connected to the central grounding point of the motor controller via a cable shield. If other shielding concepts are used, users must perform their own tests. Class A device.

### Classifications

<b>ECLASS 5.0</b>	27270590
<b>ECLASS 5.1.4</b>	27270590
<b>ECLASS 6.0</b>	27270590
<b>ECLASS 6.2</b>	27270590
<b>ECLASS 7.0</b>	27270590
<b>ECLASS 8.0</b>	27270590
<b>ECLASS 8.1</b>	27270590
<b>ECLASS 9.0</b>	27270590
<b>ECLASS 10.0</b>	27273805
<b>ECLASS 11.0</b>	27273901
<b>ECLASS 12.0</b>	27273901
<b>ETIM 5.0</b>	EC001486
<b>ETIM 6.0</b>	EC001486
<b>ETIM 7.0</b>	EC001486
<b>ETIM 8.0</b>	EC001486
<b>UNSPSC 16.0901</b>	41112113

Dimensional drawing (Dimensions in mm (inch))

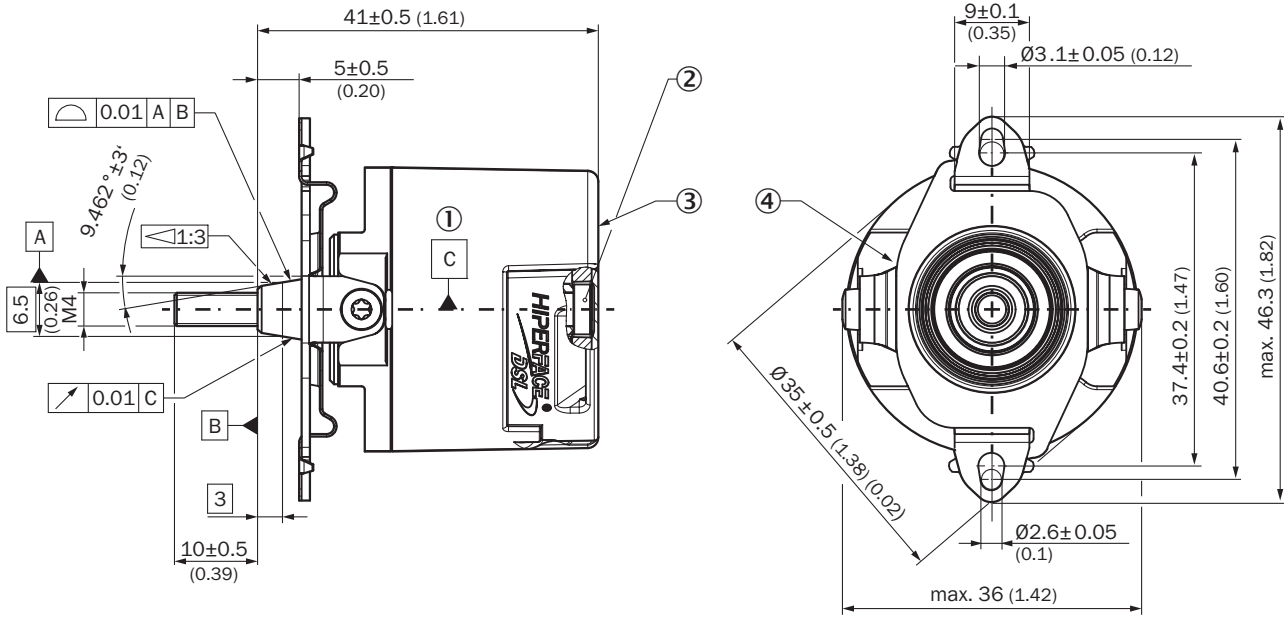

- ① Bearing of the encoder shaft
- ② Torx 15 cylinder screw
- ③ Measuring point for vibrations
- ④ Measuring point for operating temperature

Attachment specifications

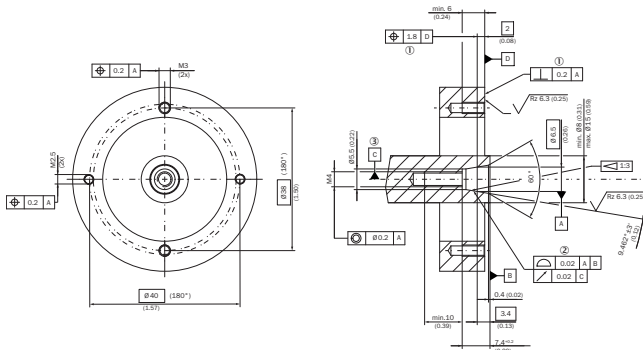

- ① Permanently
- ② Dynamic
- ③ Bearing of the drive shaft

PIN assignment

Supply / Communication pin assignment

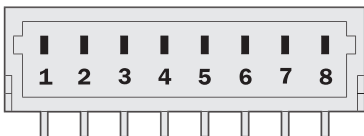

## V connection type

PIN	Signal	Explanation
1	+U <sub>S</sub>	Supply
2	GND	Ground connection
3	DSL-	DSL negative
4	DSL+	DSL positive
5	RxD+	Receiver data positive
6	RxD-	Receiver data negative
7	TxD-	Sender data negative
8	TxD+	Sender data positive

Recommended mating connector: JST (GHR-08V-S)

## Diagrams

Typical inrush current (A)

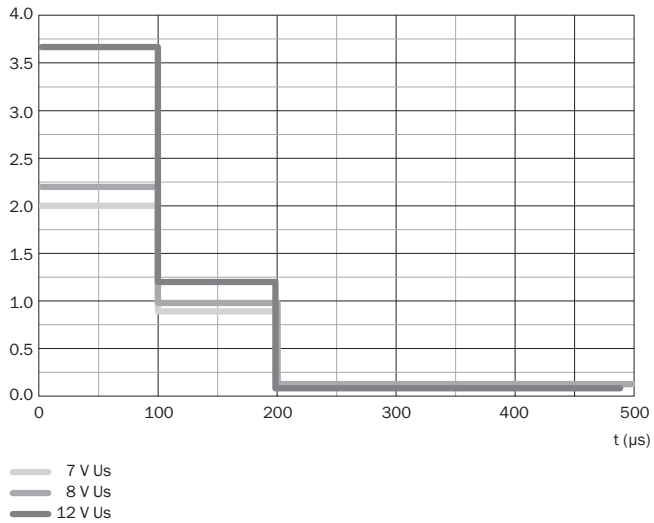

## SICK AT A GLANCE

SICK is one of the leading manufacturers of intelligent sensors and sensor solutions for industrial applications. A unique range of products and services creates the perfect basis for controlling processes securely and efficiently, protecting individuals from accidents and preventing damage to the environment.

We have extensive experience in a wide range of industries and understand their processes and requirements. With intelligent sensors, we can deliver exactly what our customers need. In application centers in Europe, Asia and North America, system solutions are tested and optimized in accordance with customer specifications. All this makes us a reliable supplier and development partner.

Comprehensive services complete our offering: SICK LifeTime Services provide support throughout the machine life cycle and ensure safety and productivity.

For us, that is “Sensor Intelligence.”

## WORLDWIDE PRESENCE:

Contacts and other locations –[www.sick.com](http://www.sick.com)