

# LL3-DH07

Fiber-optic cables

FIBERS

**SICK**  
Sensor Intelligence.



### Ordering information

Type	Part no.
LL3-DH07	5326031

Other models and accessories → [www.sick.com/Fiber-optic\\_cables](http://www.sick.com/Fiber-optic_cables)

### Detailed technical data

#### Features

<b>Device type</b>	Fiber-optic cables
<b>Functional principle</b>	Proximity system
<b>Fiber-optic head design</b>	Threaded sleeve
<b>Application</b>	Heat-resistant ( $\geq 100^{\circ}\text{C}$ )
<b>Compatible fiber-optic amplifiers</b>	WLL80, WLL180, GLL170(T)
<b>Sensing range max.</b>	1,300 mm (Sensing range of WLL80 at 8 ms)
<b>Minimal object diameter</b>	0.02 mm <sup>1)</sup>
<b>Optical fiber head</b>	
Angle of dispersion	60°
Integrated lens	No
Compatibility tip adapters	Yes
<b>Optical fiber</b>	
Compatibility with infrared light	Yes <sup>2)</sup>
Adapter end sleeves required	No
<b>Included with delivery</b>	Mounting, 2 x M4 hexagon nut, 1 x washer

<sup>1)</sup> Minimum detectable object was determined at optimum measuring distance and optimum setting.

<sup>2)</sup> Reduced sensing ranges possible when using a fiber-optic amplifier with infrared light.

#### Mechanics

<b>Optical fiber head</b>	
Light emission	Axial
Thread diameter (housing)	M4
Optical fiber taper diameter	$\geq 3$ mm
Optical fiber taper length after 2 mm	$\geq 5$ mm
<b>Optical fiber</b>	
Fiber length	1,000 mm
Bending radius	25 mm
Dynamic flexibility (robotics)	No
Outside diameter, optical fiber cable connection	2.2 mm
Fiber arrangement	Coaxial
Core structure	S: 440 x $\emptyset$ 50 $\mu\text{m}$ R: 440 x $\emptyset$ 50 $\mu\text{m}$ Coaxial
<b>Material</b>	
Optical fiber head	Copper-zinc alloy (CuZn)

	Sheath	Stainless steel
	Fibers	Glass
<b>Weight</b>		92 g

## Ambient data

<b>Ambient operating temperature</b>	-60 °C ... +200 °C
--------------------------------------	--------------------

## Classifications

<b>ECLASS 5.0</b>	27270905
<b>ECLASS 5.1.4</b>	27270905
<b>ECLASS 6.0</b>	27270905
<b>ECLASS 6.2</b>	27270905
<b>ECLASS 7.0</b>	27270905
<b>ECLASS 8.0</b>	27270905
<b>ECLASS 8.1</b>	27270905
<b>ECLASS 9.0</b>	27270905
<b>ECLASS 10.0</b>	27270905
<b>ECLASS 11.0</b>	27270905
<b>ECLASS 12.0</b>	27270905
<b>ETIM 5.0</b>	EC002651
<b>ETIM 6.0</b>	EC002651
<b>ETIM 7.0</b>	EC002651
<b>ETIM 8.0</b>	EC002651
<b>UNSPSC 16.0901</b>	39121528

## Sensing ranges with WLL80

<b>Operating mode 16 µs</b>	125 mm
<b>Operating mode 70 µs</b>	350 mm
<b>Operating mode 250 µs</b>	600 mm
<b>Operating mode 500 µs</b>	710 mm
<b>Operating mode 1 ms</b>	800 mm
<b>Operating mode 2 ms</b>	1,200 mm
<b>Operating mode 8 ms</b>	1,300 mm

## Sensing ranges with WLL180T

<b>Operating mode 16 µs</b>	65 mm
<b>Operating mode 70 µs</b>	260 mm
<b>Operating mode 250 µs</b>	670 mm
<b>Operating mode 2 ms</b>	1,340 mm
<b>Operating mode 8 ms</b>	1,430 mm
<b>Note</b>	Sensing ranges related to fiber-optic sensors with type of light: visible red light

## Sensing ranges with GLL170

<b>Operating mode 250 µs</b>	300 mm
------------------------------	--------

### Sensing ranges with GLL170T

<b>Operating mode 50 <math>\mu</math>s</b>	170 mm
<b>Operating mode 250 <math>\mu</math>s</b>	480 mm

### Dimensional drawing (Dimensions in mm (inch))

LL3-DH07

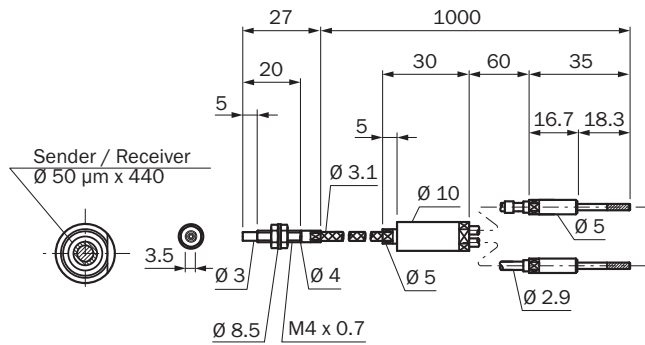

## SICK AT A GLANCE

SICK is one of the leading manufacturers of intelligent sensors and sensor solutions for industrial applications. A unique range of products and services creates the perfect basis for controlling processes securely and efficiently, protecting individuals from accidents and preventing damage to the environment.

We have extensive experience in a wide range of industries and understand their processes and requirements. With intelligent sensors, we can deliver exactly what our customers need. In application centers in Europe, Asia and North America, system solutions are tested and optimized in accordance with customer specifications. All this makes us a reliable supplier and development partner.

Comprehensive services complete our offering: SICK LifeTime Services provide support throughout the machine life cycle and ensure safety and productivity.

For us, that is “Sensor Intelligence.”

## WORLDWIDE PRESENCE:

Contacts and other locations –[www.sick.com](http://www.sick.com)