



TDC-E100R6

Telematic Data Collector

GATEWAY SYSTEMS

SICK
Sensor Intelligence.



Ordering information

Description	Network coverage	Tasks	Items supplied	Type	Part no.
The gateway networks sensors, machines and IIoT platforms for collecting and pre-processing local sensor and process data.	North America Latin American	Condition monitoring, stock monitoring, user-defined real-time alarms	TDC-E100R6 with mobile communication (without data) including connecting cables and operating instructions	TDC-E100R6	6067537

Other models and accessories → www.sick.com/Telematic_Data_Collector



Detailed technical data

Features

Product category	Gateway and cloud solutions
Tasks	Condition monitoring Stock monitoring User-defined real-time alarms

Mechanics/electronics

Supply voltage	24 V DC (9 V DC ... 36 V DC)
Power consumption	2.4 W
Housing dimensions (W x D x H)	162 mm x 32 mm x 101 mm
Weight	230 g
Housing material	Polyamide PA6
Housing color	Light blue (RAL 5012)
Fixing	In vehicle or control cabinet
Enclosure rating	IP20 (according to DIN EN 60529)

Performance

Sensor	Acceleration sensor, Magnetometer, Thermometers
Internal computer	1GB, DD3, dual-core Cortex-A7 with Cortex-M4 co-processor
Internal memory	16 GB
Operating system	Linux
Ecosystem	Docker
User interface	TDC-E Device Manager, Node-RED, picoStratus
Data protocol	MQTT REST API OPC UA WebSocket
Data format	JSON
Connectivity	Mobile communication (3G)

	WLAN WPAN LAN
Mobile network	UMTS: 850/1900/2100 MHz, GSM/EDGE: 850/900/1800/1900 MHz
Network coverage	North America, Latin American

Interfaces

Modem	✓, 3G HSPA+
Data transmission rate	(5.76 Mbit/s ... 14.4 Mbit/s)
Protocol	UMTS: 850/1900/2100 MHz GSM/EDGE: 850/900/1800/1900 MHz
Ethernet	✓ (2)
Data transmission rate	(10 Mbit/s ... 1,000 Mbit/s)
Electrical connection	RJ45
WLAN	✓
Data transmission rate	(80 Mbit/s ... 100 Mbit/s), single band 2.4 GHz
Protocol	IEEE 802.11 b/g/n
WPAN	✓, IEEE 802.15.1, IEEE 802.15.4
Serial	✓, RS-232, RS-422, RS-485, SSI, 1Wire
Electrical connection	Micro-Fit (20-pin)
CAN bus	✓ (2)
Data transmission rate	1 Mbit/s, adjustable
Protocol	J1939, CANOpen
Electrical connection	Micro-Fit (20-pin)
USB	✓, USB 2.0
Electrical connection	USB 2.0 A-Male connector
Inputs/outputs	
I/O	6 analog inputs (configurable, current and voltage), 8 digital inputs/outputs (configurable)
Optical indicators	3, LED, status displays
Configuration interface	Web-Interface

Ambient data

Ambient temperature, operation	-20 °C ... +70 °C
Ambient temperature, storage	-40 °C ... +85 °C
Shock load	IEC 60068-2-27
Electromagnetic compatibility (EMC)	EN 303446-1 EN 55032 EN 55024 EN 61000-3-2 EN 61000-3-3
Product safety	EN 60950-1
Radio approval	EN 301511 V12.5.1 (2017)

General notes

Description	The gateway networks sensors, machines and IIoT platforms for collecting and preprocessing local sensor and process data.
Items supplied	TDC-E100R6 with mobile communication (without data) including connecting cables and operating instructions

Classifications

eCI@ss 5.0	19179090
eCI@ss 5.1.4	19179090
eCI@ss 6.0	19179090
eCI@ss 6.2	19179090
eCI@ss 7.0	19179090
eCI@ss 8.0	19179090
eCI@ss 8.1	19179090
eCI@ss 9.0	19179090
eCI@ss 10.0	19179090
eCI@ss 11.0	19179090
eCI@ss 12.0	19179090
UNSPSC 16.0901	43222605

Dimensional drawing (Dimensions in mm (inch))

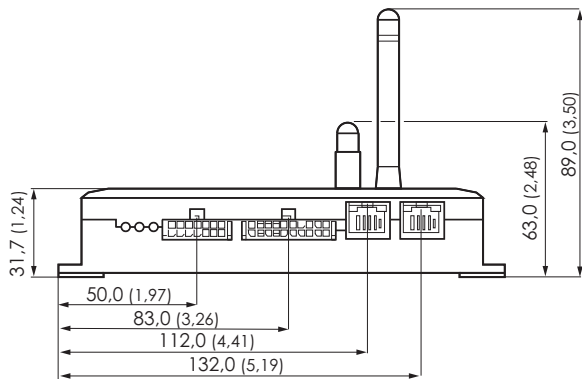
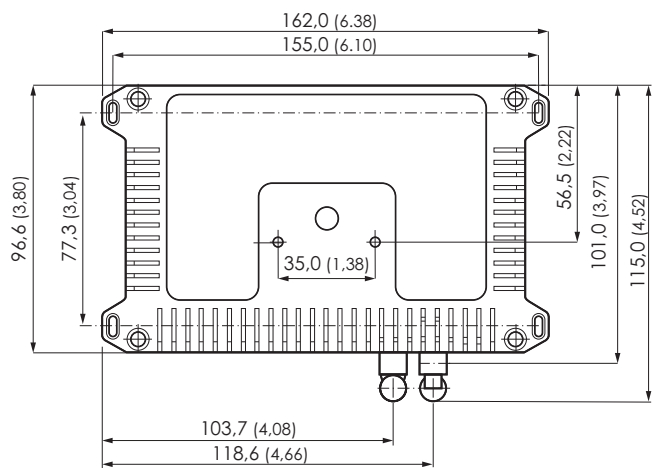

SICK AT A GLANCE

SICK is one of the leading manufacturers of intelligent sensors and sensor solutions for industrial applications. A unique range of products and services creates the perfect basis for controlling processes securely and efficiently, protecting individuals from accidents and preventing damage to the environment.

We have extensive experience in a wide range of industries and understand their processes and requirements. With intelligent sensors, we can deliver exactly what our customers need. In application centers in Europe, Asia and North America, system solutions are tested and optimized in accordance with customer specifications. All this makes us a reliable supplier and development partner.

Comprehensive services complete our offering: SICK LifeTime Services provide support throughout the machine life cycle and ensure safety and productivity.

For us, that is “Sensor Intelligence.”

WORLDWIDE PRESENCE:

Contacts and other locations –www.sick.com